

DATA SHEET

For a complete data sheet, please also download:

- The IC04 LOCMOS HE4000B Logic Family Specifications HEF, HEC
- The IC04 LOCMOS HE4000B Logic Package Outlines/Information HEF, HEC

HEF4543B

MSI

BCD to 7-segment
latch/decoder/driver

Product specification
File under Integrated Circuits, IC04

January 1995



BCD to 7-segment latch/decoder/driver

**HEF4543B
MSI**

DESCRIPTION

The HEF4543B is a BCD to 7-segment latch/decoder/driver for liquid crystal and LED displays. It has four address inputs (D_A to D_D), an active HIGH latch disable input (LD), an active HIGH blanking input (BI), an active HIGH phase input (PH) and seven buffered segment outputs (O_a to O_g).

The circuit provides the function of a 4-bit storage latch and an 8-4-2-1 BCD to 7-segment decoder/driver. It can invert the logic levels of the output combination. The phase (PH), blanking (BI) and latch disable (LD) inputs are used to reverse the function table phase, blank the display and store a BCD code, respectively.

For liquid crystal displays a square-wave is applied to PH and the electrical common back-plane of the display. The outputs of the device are directly connected to the segments of the liquid crystal.

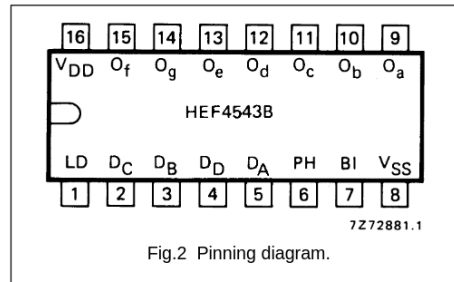
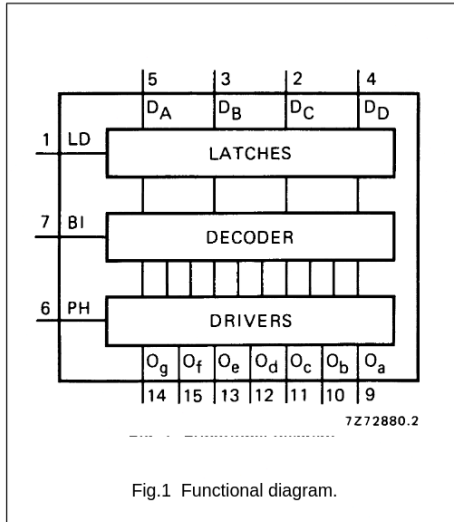

- HEF4543BP(N): 16-lead DIL; plastic (SOT38-1)
- HEF4543BD(F): 16-lead DIL; ceramic (cerdip) (SOT74)
- HEF4543BT(D): 16-lead SO; plastic (SOT109-1)
- (): Package Designator North America

PINNING

- D_A to D_D address (data) inputs
- PH phase input (active HIGH)
- BI blanking input (active HIGH)
- LD latch disable input (active HIGH)
- O_a to O_g segment outputs

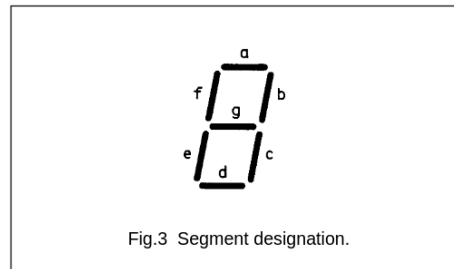

FAMILY DATA, I_{DD} LIMITS category MSI

See Family Specifications

BCD to 7-segment latch/decoder/driver

HEF4543B
MSI

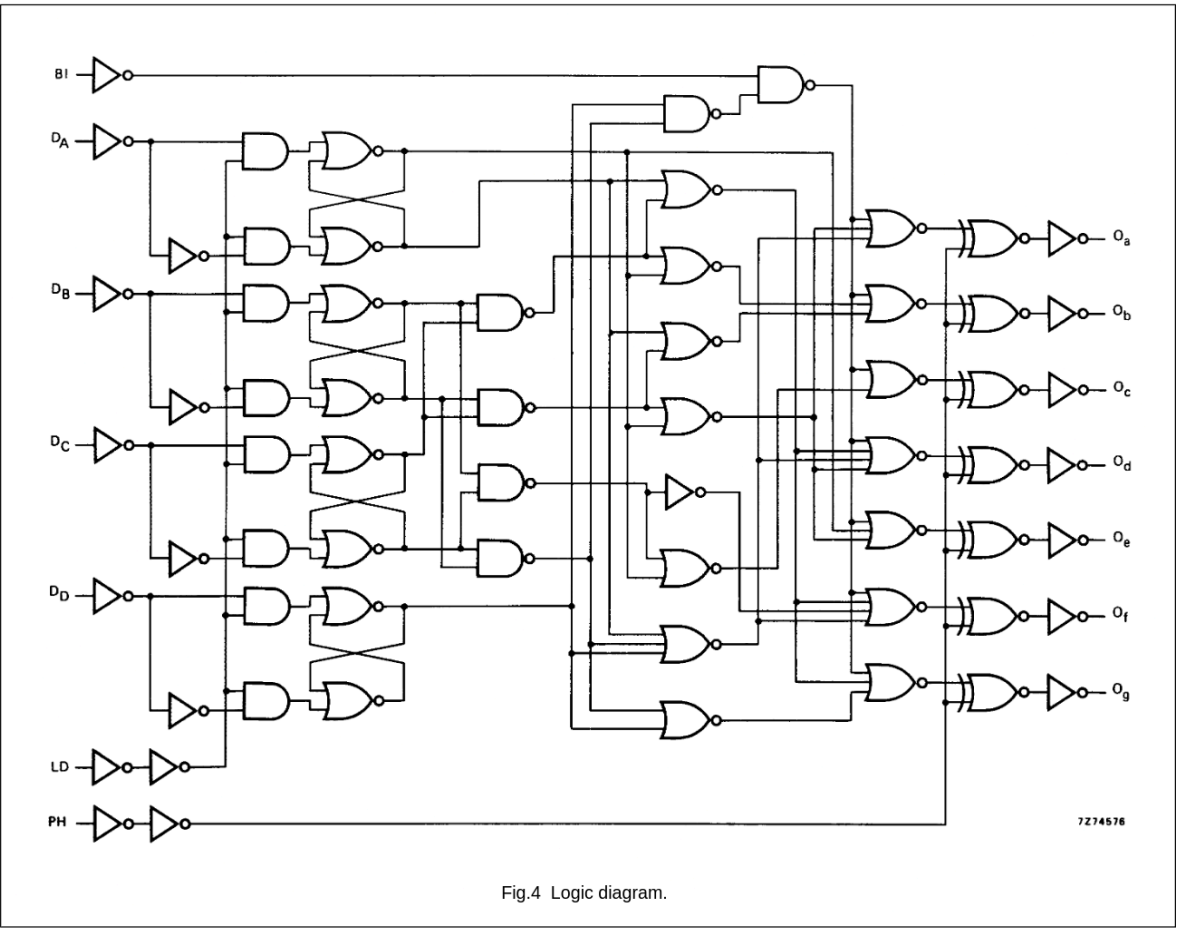

Fig.4 Logic diagram.

BCD to 7-segment latch/decoder/driver

HEF4543B
MSI

FUNCTION TABLE

INPUTS							OUTPUTS							
LD	BI	PH ⁽⁴⁾	D _D	D _C	D _B	D _A	O _a	O _b	O _c	O _d	O _e	O _f	O _g	DISPLAY
X	H	L	X	X	X	X	L	L	L	L	L	L	L	blank
H	L	L	L	L	L	L	H	H	H	H	H	H	L	0
H	L	L	L	L	L	H	L	H	H	L	L	L	L	1
H	L	L	L	L	H	L	H	H	L	H	H	L	H	2
H	L	L	L	L	H	H	H	H	H	H	L	L	H	3
H	L	L	L	H	L	L	L	H	H	L	L	H	H	4
H	L	L	L	H	L	H	H	L	H	H	L	H	H	5
H	L	L	L	H	H	L	H	L	H	H	H	H	H	6
H	L	L	L	H	H	H	H	H	H	L	L	L	L	7
H	L	L	H	L	L	L	H	H	H	H	H	H	H	8
H	L	L	H	L	L	H	H	H	H	H	L	H	H	9
H	L	L	H	L	H	L	L	L	L	L	L	L	L	blank
H	L	L	H	L	H	H	L	L	L	L	L	L	L	blank
H	L	L	H	H	L	L	L	L	L	L	L	L	L	blank
H	L	L	H	H	L	H	L	L	L	L	L	L	L	blank
H	L	L	H	H	H	L	L	L	L	L	L	L	L	blank
H	L	L	H	H	H	H	L	L	L	L	L	L	L	blank
L	L	L	X	X	X	X	(5)							(5)
as above	H		as above				inverse of above							as above

Notes

1. H = HIGH state (the more positive voltage)
2. L = LOW state (the less positive voltage)
3. X = state is immaterial
4. For liquid crystal displays, apply a square-wave to PH.
For common cathode LED displays, select PH = LOW.
For common anode LED displays, select PH = HIGH.
5. Depends upon the BCD-code previously applied when LD = HIGH.

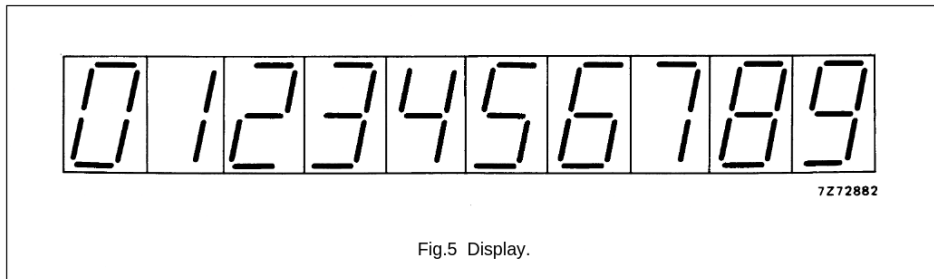

Fig.5 Display.

BCD to 7-segment latch/decoder/driver

HEF4543B

MSI

AC CHARACTERISTICS

 $V_{SS} = 0\text{ V}$; $T_{amb} = 25\text{ °C}$; $C_L = 50\text{ pF}$; input transition times $\leq 20\text{ ns}$

	V_{DD} V	SYMBOL	MIN.	TYP.	MAX.	TYPICAL EXTRAPOLATION FORMULA	
Propagation delays $D_n \rightarrow O_n$ HIGH to LOW	5	t_{PHL}	180	360	ns	$153\text{ ns} + (0,55\text{ ns/pF}) C_L$	
	10		75	150	ns	$64\text{ ns} + (0,23\text{ ns/pF}) C_L$	
	15		55	110	ns	$47\text{ ns} + (0,16\text{ ns/pF}) C_L$	
	LOW to HIGH	5	t_{PLH}	180	360	ns	$153\text{ ns} + (0,55\text{ ns/pF}) C_L$
		10		75	150	ns	$64\text{ ns} + (0,23\text{ ns/pF}) C_L$
		15		55	110	ns	$47\text{ ns} + (0,16\text{ ns/pF}) C_L$
LD $\rightarrow O_n$ HIGH to LOW	5	t_{PHL}	170	340	ns	$143\text{ ns} + (0,55\text{ ns/pF}) C_L$	
	10		80	160	ns	$69\text{ ns} + (0,23\text{ ns/pF}) C_L$	
	15		60	120	ns	$52\text{ ns} + (0,16\text{ ns/pF}) C_L$	
	LOW to HIGH	5	t_{PLH}	190	380	ns	$163\text{ ns} + (0,55\text{ ns/pF}) C_L$
		10		80	160	ns	$69\text{ ns} + (0,23\text{ ns/pF}) C_L$
		15		60	120	ns	$52\text{ ns} + (0,16\text{ ns/pF}) C_L$
BI $\rightarrow O_n$ HIGH to LOW	5	t_{PHL}	145	290	ns	$118\text{ ns} + (0,55\text{ ns/pF}) C_L$	
	10		65	130	ns	$54\text{ ns} + (0,23\text{ ns/pF}) C_L$	
	15		45	90	ns	$37\text{ ns} + (0,16\text{ ns/pF}) C_L$	
	LOW to HIGH	5	t_{PLH}	125	250	ns	$98\text{ ns} + (0,55\text{ ns/pF}) C_L$
		10		55	110	ns	$54\text{ ns} + (0,23\text{ ns/pF}) C_L$
		15		40	80	ns	$32\text{ ns} + (0,16\text{ ns/pF}) C_L$
Output transition times HIGH to LOW	5	t_{THL}	60	120	ns	$10\text{ ns} + (1,0\text{ ns/pF}) C_L$	
	10		30	60	ns	$9\text{ ns} + (0,42\text{ ns/pF}) C_L$	
	15		20	40	ns	$6\text{ ns} + (0,28\text{ ns/pF}) C_L$	
	LOW to HIGH	5	t_{TLH}	60	120	ns	$10\text{ ns} + (1,0\text{ ns/pF}) C_L$
		10		30	60	ns	$9\text{ ns} + (0,42\text{ ns/pF}) C_L$
		15		20	40	ns	$6\text{ ns} + (0,28\text{ ns/pF}) C_L$
Minimum LD pulse width; HIGH	5	t_{WLDH}	60	30	ns		
	10		30	15	ns		
	15		20	10	ns		
Set-up time $D_n \rightarrow LD$	5	t_{su}	40	20	ns		
	10		20	5	ns		
	15		15	0	ns		
Hold time $D_n \rightarrow LD$	5	t_{hold}	0	-15	ns		
	10		15	0	ns		
	15		20	5	ns		

BCD to 7-segment latch/decoder/driver

HEF4543B

MSI

	V_{DD} V	TYPICAL FORMULA FOR P (μ W)	
Dynamic power	5	$2\ 200 f_i + \sum (f_o C_L) \times V_{DD}^2$	where
dissipation per	10	$10\ 400 f_i + \sum (f_o C_L) \times V_{DD}^2$	f_i = input freq. (MHz)
package (P)	15	$33\ 000 f_i + \sum (f_o C_L) \times V_{DD}^2$	f_o = output freq. (MHz)
			C_L = load capacitance (pF)
			$\sum (f_o C_L)$ = sum of outputs
			V_{DD} = supply voltage (V)

APPLICATION INFORMATION

Some examples of applications for the HEF4543B are:

- Driving LCD displays.
- Driving LED displays.
- Driving fluorescent displays.
- Driving incandescent displays.
- Driving gas discharge displays.

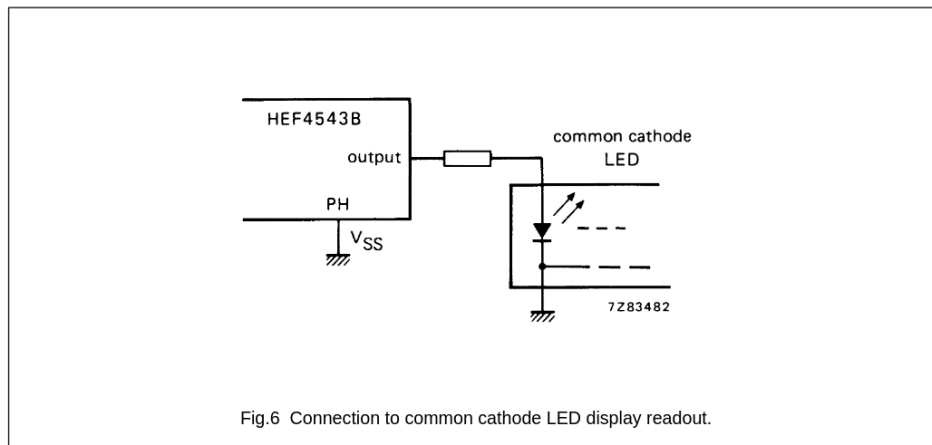

BCD to 7-segment latch/decoder/driver

HEF4543B
MSI

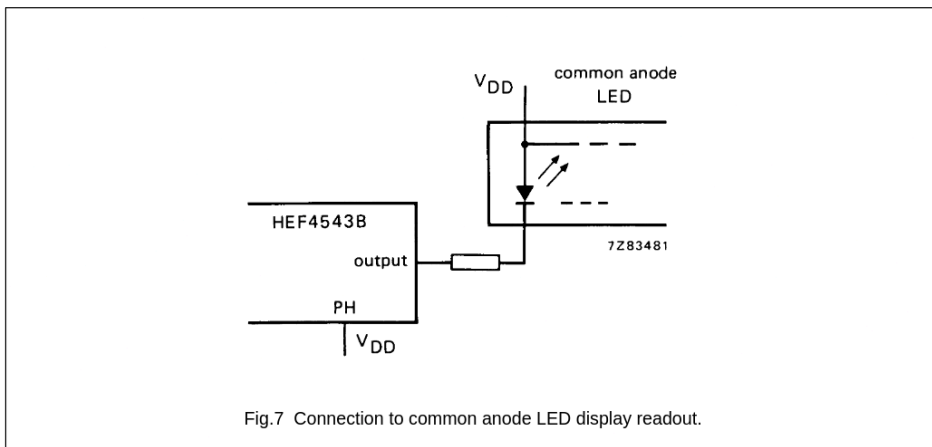

Fig.7 Connection to common anode LED display readout.

Note to Figs 6 and 7: bipolar transistors may be added for gain where $V_{DD} \leq 10\text{ V}$ or $I_{out} \geq 10\text{ mA}$.

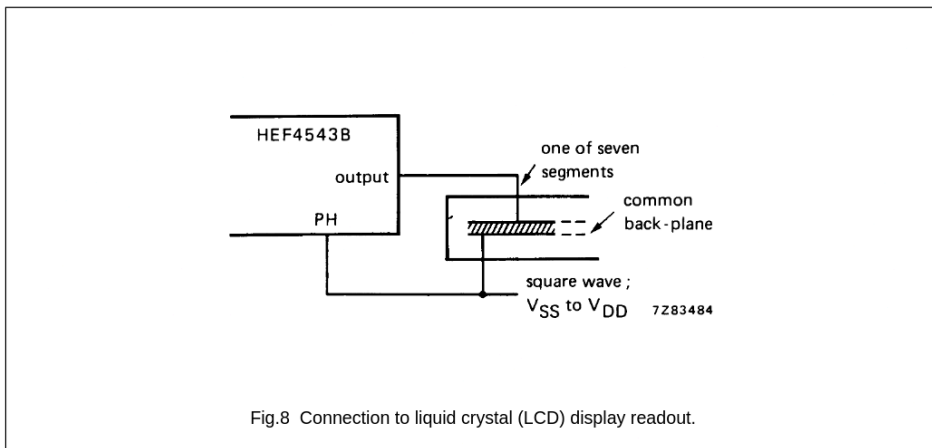

Fig.8 Connection to liquid crystal (LCD) display readout.

BCD to 7-segment latch/decoder/driver

HEF4543B
MSI

