



MIC10941/10939

V. F. Alphanumeric and Bargraph Display Controller

Summary Information*—Not Recommended for New Designs

General Description

The MIC10941 and MIC10939 Alphanumeric and Bargraph Display Controller is a two-chip MOS/LSI general purpose display controller system designed to interface with bargraph and segmented displays (vacuum fluorescent or LED).

The two-chip set will drive displays with up to 16 segments (plus decimal point and comma tail) and up to 20 grids (characters) plus a cursor. The chips can be cascaded to drive larger displays of 80 characters. Segment decoding for ASCII characters and bargraph patterns is accomplished through an internal PLA.

Micrel has received the rights from Rockwell International to manufacture and market this product and reproduce the specifications, including references to Rockwell.

Features

- 20-character display driver cascadable to 80 characters
- Direct drive capability for vacuum-fluorescent displays
- 128 × 18 PLA provides segment decoding for ASCII characters (all caps only) and bargraph patterns
- Serial or parallel data input for 8-bit display and control characters
- Brightness, refresh rate, and display mode controls
- Separate cursor driver output
- 40-pin DIP or 44-pin PLCC (MIC10939)
- 24-pin DIP package (MIC10941)

Ordering Information

Part Number	Temperature Range	Package
MIC10941P-50	0°C to +70°C	24-pin P-DIP
MIC10941PE-50	-40°C to +85°C	24-pin P-DIP
MIC10939J-50	0°C to +70°C	44-pin PLCC
MIC10939P-50	0°C to +70°C	40-pin P-DIP
MIC10939PE-50	-40°C to +85°C	40-pin P-DIP

Block Diagram

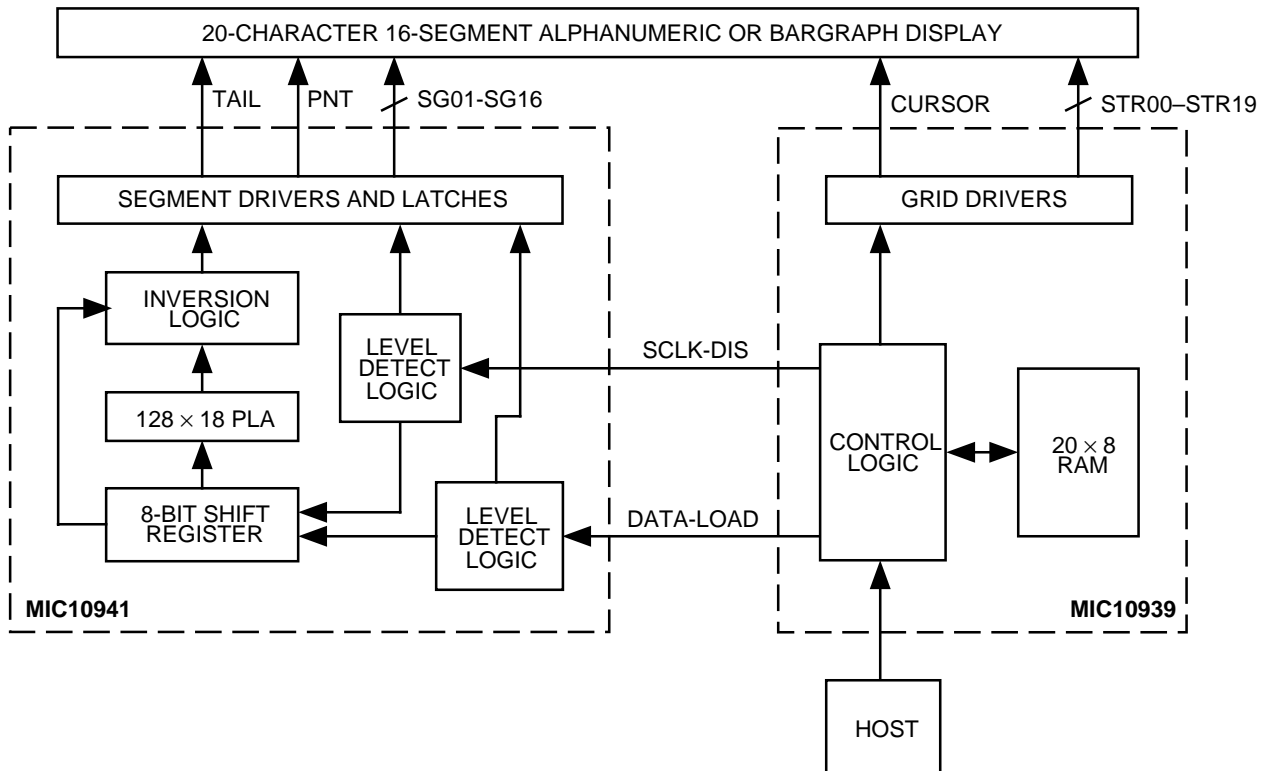

* Contact Micrel for more information.