

DESCRIPTION

The UM1285-8 is a high performance Intercarrier Vestigial Sideband Modulator which is primarily intended for use in color TV games, VTR's, computer graphics, Teletext and view data adapters. The UM1285-8 has a very linear transfer characteristic which ensures a good grey scale, controlled chroma levels and freedom from sync compression with its associated frame and line jitter problems. Good subcarrier intermodulation performance minimizes the on-screen bar pattern due to chroma and sound subcarrier beats.

FEATURES:

- Compact and Low Profile.
- Rugged and Stable.
- Good Modulation Linearity.
- Low Chroma/Sound Beat Product (55dB Typical).
- Pretuned Vision Carriers CH3, CH4.
- Pretuned Sound Subcarrier 4.5MHz.
- Pretuned Vestigial Sideband Filter.
- Built-In Voltage Regulator.
- Negative Transfer Characteristic.
- Low Radiation (FCC Approvable).
- For Color Application.
- 75 Ohm Output from a Standard Phono Socket.
- Designed for PCB Insertion.

ABSOLUTE MAXIMUM RATINGS:

Applied voltage between Pin 1, 3, 4, and Case (See Pin Connection) should be from -3.0V to +15V.

Applied voltage between Pin 3 and Case should be from -3.0V to +8.0V. (Refer to Table 1 for higher voltage application.)

Operating Temperature Range = 0°C to +45°C.

Storage Temperature Range = -20°C to +70°C.

CHARACTERISTICS

The UM1285-8 is designed to operate over a supply voltage range of 6V to 15V. A built-in 5.0V voltage regulator is provided to achieve excellent stability against voltage change. An external series resistor is required on the supply voltage input for current limiting purposes. Table 1 shows the value of the series resistor required for various supply voltages.

Modulation occurs when a positive going voltage is applied to the video input pin. The transfer characteristic is negative (See Graph). As a result, a positive going input causes the RF output to decrease. Peak RF output is specified when the video input is at 2.2V.

The user can select between CH3 and CH4 operation by switching the Channel Select Pin to ground (0V) for CH3 or to an open circuit for CH4.

Supply Voltage V_{CC}	Volt	6.0	7.5	9.0	12.0	15.0
Series Resistor R_S	Ohm	0	47	100	180	270

Table 1: Series Resistor with respect to supply voltage.

FCC APPROVAL

The UM1285-8 is FCC approvable due to its very low radiation, stabilized carrier oscillators, and vestigial sideband filter which ensures that all sideband components outside FCC limits are greater than 30dB down.

NOTE:

To use the UM1285-8 in the USA, it is absolutely mandatory that the finished product using this device, in its final production form, first be submitted to the FCC for testing and certification under the 'TV device, Class 1' classification.

TYPICAL INPUT WAVEFORM

AC Coupled Input

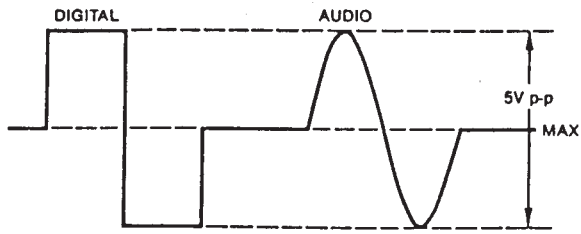

TYPICAL SOUND I/P SETUP

DC Coupled Input

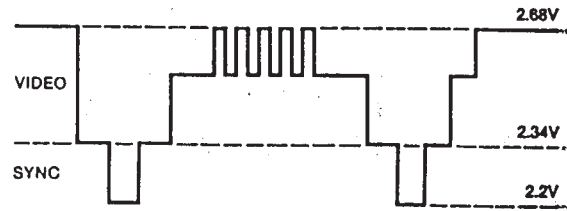

TYPICAL MODULATION INPUT VOLTAGE SETUP

TEST CIRCUIT

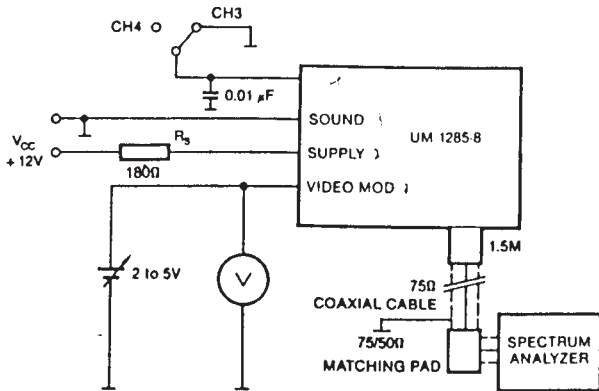

NOTE:

1. In case of testing with 50Ω I/P spectrum analyzer, matching pad of 75/50Ω (ATTEN 10dB) should be employed.
2. Standard RF coaxial cable should be 1.5M long and 75Ω characteristic impedance.

TYPICAL APPLICATION

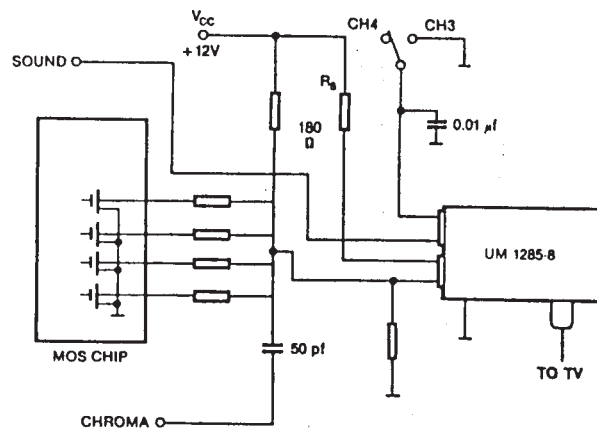

RECOMMENDED PCB HOLE CENTERS (COMPONENT SIDE)

(millimeters)

LEAD	FUNCTION
1	Composite Video Input (V_{MOD}).
2	Supply (V_{CC}).
3	Audio Input (V_{SMOD}).
4	Channel Select.
Case	Ground.

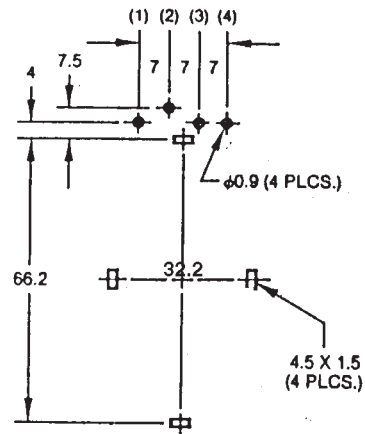

RF output LOAD = 75 Ohms

SYMBOL	DESCRIPTION	MIN	TYP	MAX	UNIT
F _C	CH3 Video Carrier @25°C	61.00	61.25	61.50	MHz
F _C	CH4 Video Carrier @25°C	67.40	67.65	67.90	MHz
F _{SC}	Sound Carrier @25°C	4.480	4.500	4.520	MHz
V _{O(HI)}	Video Carrier Output (V _{MOD} = 2.2V)	0.8	1.5	2.5	mV _{RMS}
V _{O(LO)}	Video Carrier Output (V _{MOD} = 2.8V)	14	18		- dB w.r.t. V _{O(HI)}
V _{OSC}	Sound Carrier Output	26	22	18	- dB w.r.t. V _{O(HI)}
V _S	Spurious/Harmonic			30	- dB w.r.t. V _{O(HI)}
V _{SWR}	Voltage Standing Wave Ratio (CH3 and CH4)		1.7	2.5	
ΔF _{C(T)}	ΔF for change in temp			± 10	kHz/°C
ΔF _{SC(T)}	ΔF for change in temp			± 750	Hz/°C
ΔF _C	ΔF for 1 Volt change in V _{CC}			± 30kHz	kHz/V
ΔF _{SC}	ΔF for 1 Volt change in V _{CC}			± 5kHz	kHz/V
Z _O	RF Output Impedance		75		Ohm
RF _{BW}	- 3dB Bandwidth (RF) CH3 CH4	10 4.5	14 5.0		MHz MHz
I _{CC}	Supply Current		30	40	mA
ΔF/ΔV 920kHz	Frequency Modulating Sensitivity Chroma/Sound Beat Level	4.0 48	8 55	12	kHz/Volt - dB w.r.t. V _{O(HI)}
Z _{IN}	Video Input Impedance	See Modulation Transfer Characteristic			

TYPICAL TRANSFER CHARACTERISTIC

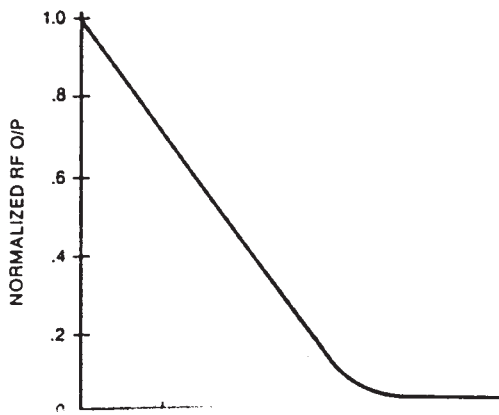

TYPICAL BANDPASS FILTER RESPONSE

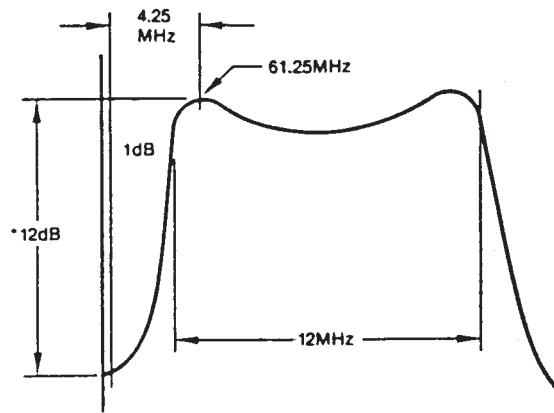

RF OUTPUT SOCKET
(millimeters)

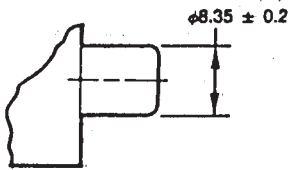

PHONO SOCKET

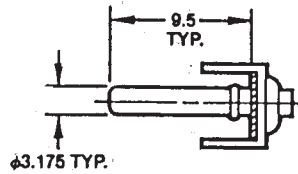

TYPICAL PHONO PLUG

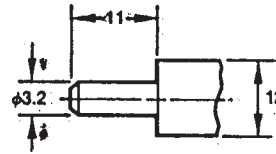

STANDARD TEST PIN

The modulator shall completely accept a standard test pin, as an assurance against excessive solder, etc. blocking up phono socket.

OUTLINE DRAWING FOR UM1285-8
(millimeters)

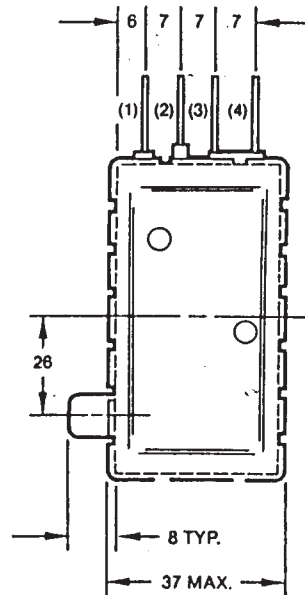
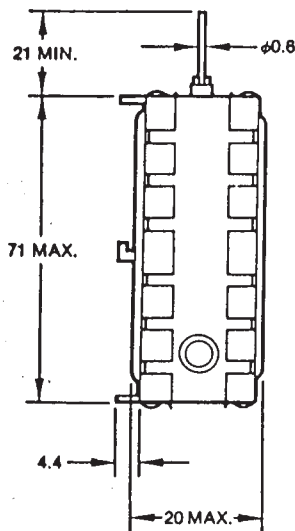

STANDARD PACKING

225 units in a shipping carton
Shipping Carton:
Gross Weight: 40 lbs. or 18 kg
Size: 12x18x16 in. or 30x45x40 cm
Volume: 2 cu. ft. or 0.054 cu. m.

2/85 Printed in U.S.A.



ASTEC USA

2880 San Tomas Expressway, Suite 200
Santa Clara, CA 95051 U.S.A.
TEL: (408) 748-1200
TELEX: 474-5018 ASTEC UI
FAX: (408) 727-8281

CONNECTIONS FOR USE WITH NTSC 75Ω
 VIDEO INPUT, NOMINAL 1.0V PP VIDEO +.4VPP SYNC.

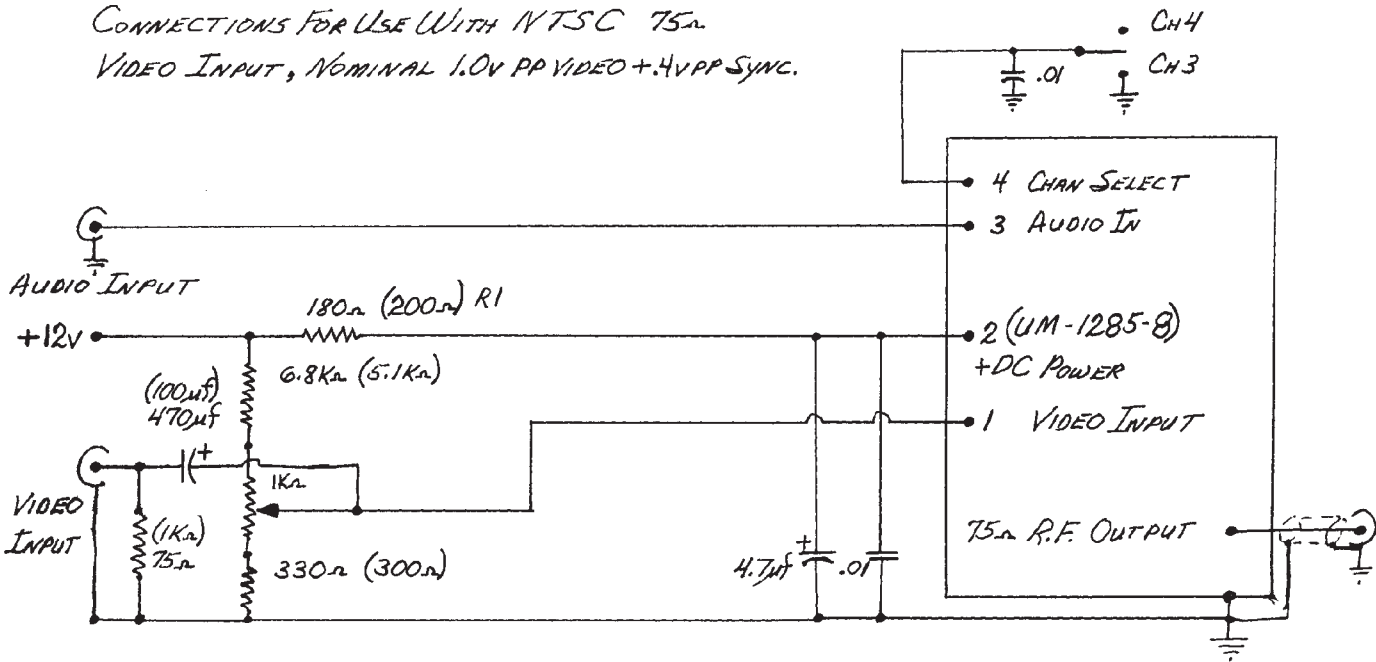

NOTES:

1. VALUES IN () FOR HIGH IMPEDANCE INPUT.
2. NORMAL VALUES FOR STD 75Ω SUCH AS CAMERA OR VCR.
3. UNIT WILL OPERATE FROM 6V TO 15V D.C. INPUT. ADJUST R1 ACCORDINGLY NOM CURRENT: 40Ma.

FOR HIGH LEVEL AUDIO WITH PRE-EMPHASIS

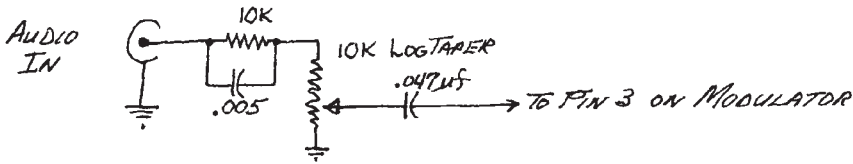

ALTERNATE VIDEO INPUT

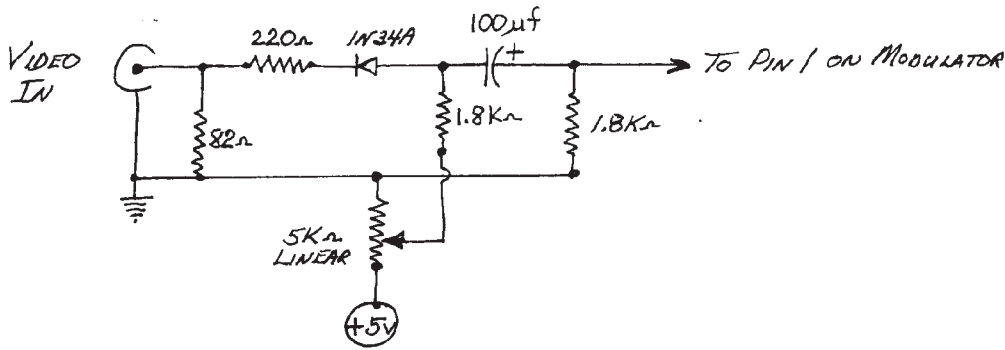

ALL RESISTORS IN OHMS: 1/4w, 10%
 ALL CAPACITORS IN µF.