

7282-742 01 PCB ASSEMBLY

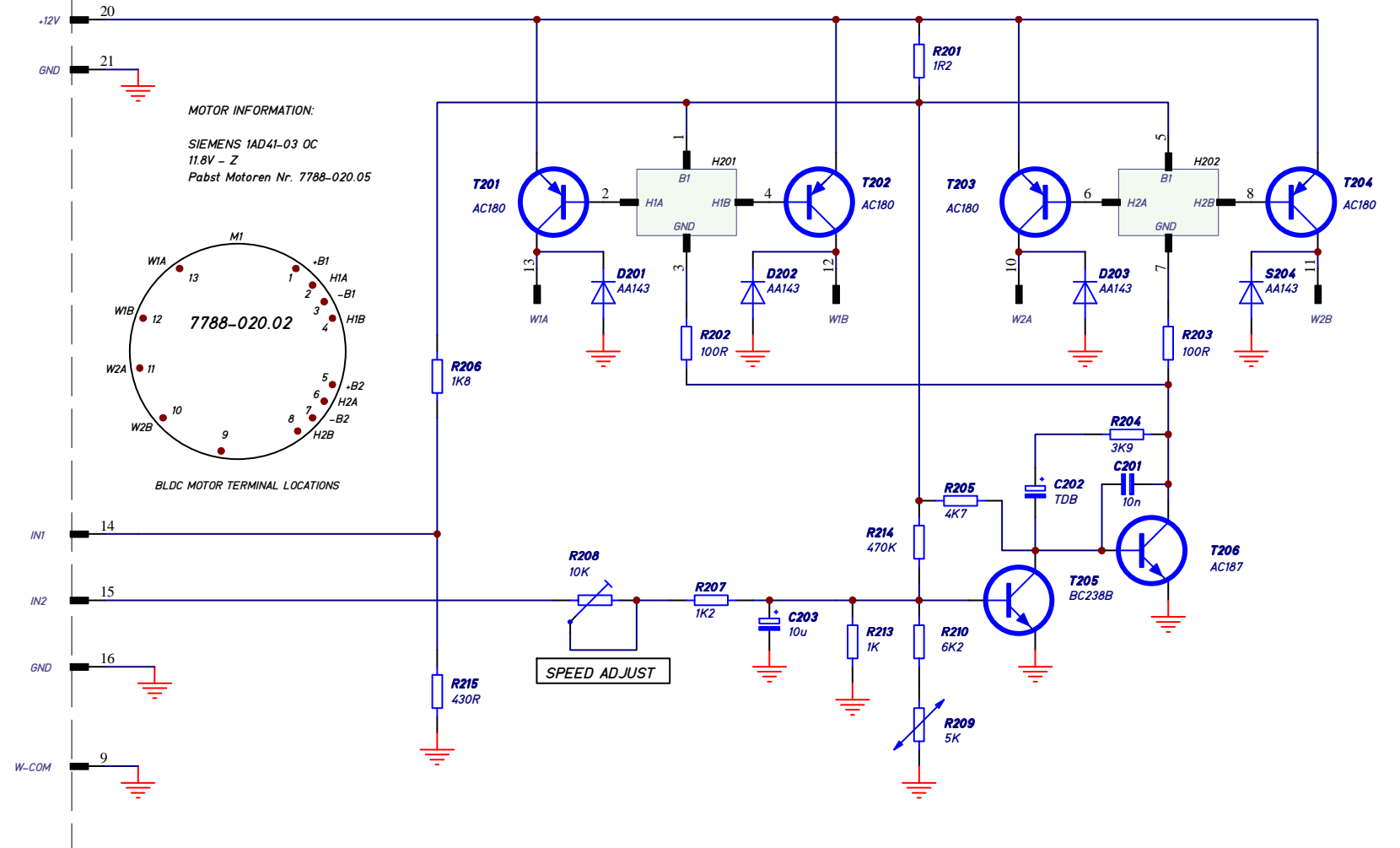

Unless otherwise specified, all values are as follows:
 resistor values are in Ohms, i.e. 0R47, 5R6, 220, 5K6, 22K
 capacitor values are in Microfarads, i.e. 220p, 0u1, 2u2, 33
 inductor values are in Microhenries, i.e. 0u22, 5u6, 68, 2m2

This drawing is our property. Duplication, unauthorized use of any kind is prohibited.

Without Approval use only for inquiry.

PCB Name: <i>BLDC MOTOR CONTROLLER</i>		Title: <i>Pabst BLDC Motor Controller</i>	
PCB Nr. <i>7282-742.01</i>		Used in <i>PHILIPS CASSETTE</i>	
PCB Type: <i>UNKNOWN</i>		Scale: <i>N/A</i>	Repl.for <i>N/A</i>
Change Index	Change Notification Nr.	Date	Name
Drawn	<i>29-Feb-2012</i>	<i>GJO</i>	
Modified			
Checked			
<input type="checkbox"/> Prototype <input checked="" type="checkbox"/> Production <input type="checkbox"/> BOM Done?		Drw. Type: <i>PCB SCHEMATIC</i>	Prj. Nr. <i>12001</i>
		Size: <i>A</i>	Rev: <i>0</i>
		Drw. Nr. <i>909.01-0002.0001/0(5)</i>	
		File: <i>PabstMotor.sch</i>	

Build No. <i>1</i>
Sheet <i>1</i> of <i>1</i>