

MEAN WELL SPS USER MANUAL

1. INPUT

1.1 INPUT VOLTAGE

Switching Power Supplies (SPS) are widely used all over the world. Many types of products are available for both alternating and direct current input. Before using any power supply, ensure that the output voltage and current is suitable for the intended load. Verify the correct input connections and any other conditions that might affect the power supply's operation.

If an input voltage is applied which is different from the power supply's rating, the unit may be damaged. Also remember that if the input voltage wave is distorted, the power supply may not operate normally, even though the measured voltage is within the allowable range.

For all Mean Well Safety Approved Models refer to the label on the power supply for the input voltage range.

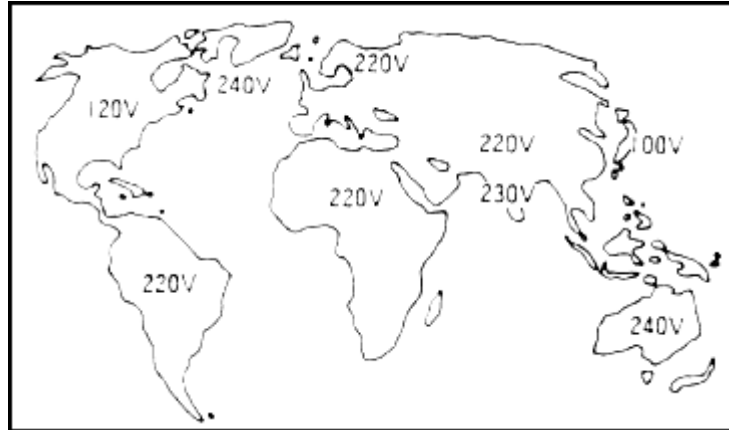

Fig. 1

1.2 INPUT CURRENT

Standard switching power supplies directly rectify the input Alternating Current (AC). Most standard units are capacitor-input-type, rectifying systems in which rectified current flows through the smoothing or filtering capacitor. Therefore, the input current is determined by the output power, input voltage, power factor, and efficiency.

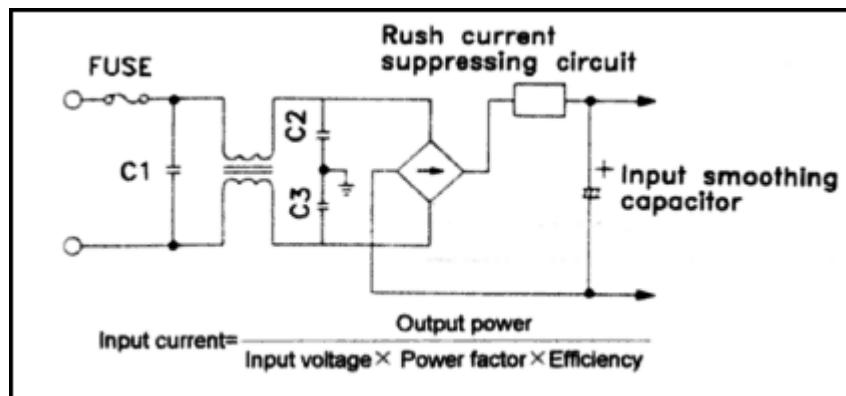

Fig. 2

The power factor of the typical switching power supply is between 0.4 and 0.6. For active Power Factor Correction (PFC) units it's normally greater than 0.9

1.3 INRUSH CURRENT

When power is applied, a large current flows to charge the input smoothing or filter capacitor. This current is called the "inrush current". The value of the inrush current varies according to the power-on timing and the presence or absence of the inrush current protection devices. The inrush current is many times larger than the normal input current. The more switching power supplies used in the same system, the larger the inrush current. Please ensure that fuses, switches, and other parts connected to the input supply side are appropriately selected.

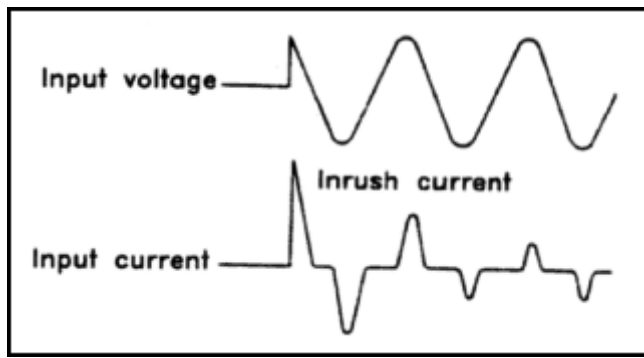

Fig. 3

If the switching power supply's fuse is blown, do not replace the fuse and operate the unit before rectifying the problem that caused it to fail – this may cause further damage to the power supply! Always replace the fuse with the same rated type. Always remove power to the unit before attempting to replace the fuse. **WARNING: High voltage inside - do not open the case. Always return to an authorized agent for any repair.**

2. OUTPUT

2.1 MAXIMUM OUTPUT POWER

Maximum power output (P_{out}) is defined as: **$P_{out} = V_{out} \times I_{out}$**

Where V_{out} is the output voltage and I_{out} is the output current. Most power supplies allow V_{out} to be adjusted. However, P_{out} must remain constant. Therefore, if V_{out} is increased, the maximum I_{out} must be decreased.

E.g. The NES-50-5 power supply has an output voltage of 5 volts and an output current of 10 amps. The maximum power output is 50 watts. The adjustable voltage range is 4.75 volts to 5.5 volts. If the output voltage is adjusted to 5.5 volts, the maximum output current can be calculated by:

$$I_{out} = P_{out} / V_{out}$$

$$\text{i.e. } I_{out} = 50 \text{ watts} / 5.5 \text{ volts} = 9.09 \text{ amps.}$$

The output voltage can also be adjusted lower than 5 volts. However, due to the design of the output circuit, exceeding the 10 amp maximum output is not recommended as over current protection may activate.

Some multiple output power supplies have a Current Range that exceeds the Output Rated Current. The table below has some specifications for the D-60A (dual output) power supply.

Channel	Output Voltage	Output Rated Current	Output Current Range
1	5V	4A	0.3 ~ 6A
2	12V	3A	0.2 ~ 4A

Ch. 1 can output 6 amps but the total power output cannot exceed 60 watts. For example, if Ch. 1 was operated at a 5.5 amp output, the Ch. 2 output current would have to be reduced to remain within the 60 watt limit. The total output power for Ch. 1 would be: (5 volts) x (5.5 amps) = 27.5 watts. This would allow 32.5 watts for Ch. 2. The total current available for Ch. 2 is: 32.5 / 1.2 = 2.7 amps.

2.2 OVERCURRENT PROTECTION (OCP) / OVERLOAD PROTECTION (OLP)

Mean Well Power Supplies are equipped with a protection circuit that will automatically operate when the output current and/or output power exceeds a minimum 105% of the rating.

Types of Protection:

a. Foldback Current Limiting:

The Foldback Current Limiting circuit is designed to linearly decrease both the voltage and current to a level that will prevent the power supply from being damaged during overcurrent/overload conditions. Foldback Current Limiting is most often used in linear power supplies but it is sometimes used in switching power supplies.

b. Constant Current Limiting:

Constant Current Limiting allows the output current to remain stable, but reduces the output voltage to a level that permits the safe operation of the power supply. Constant Current Limiting is preferred when driving devices such as motors, incandescent lamps and highly capacitive loads which have a high initial current. It's also preferred for charging lead-acid batteries.

c. Constant Power Limiting:

Constant Power Limiting linearly reduces the output voltage and simultaneously allows the output current to increase. Constant power limiting is most often used in multiple voltage output switching power supplies. See example of D-60A in section 2.1

d. Hiccup Current Limiting:

When overloaded, the output voltage and current will be shut down for a short period of time and then automatically attempt to recover again until the fault condition is removed. In a few cases (S-150) the output voltage is shut down permanently, reducing the output voltage and current to zero. A manual recovery is then necessary. Some power supplies may have constant current down to 75% or 50% of the rated output voltage below this the hiccup mode operates. In some cases the power supply will operate in constant current mode and then shutdown after a time delay of 3 to 5 seconds.

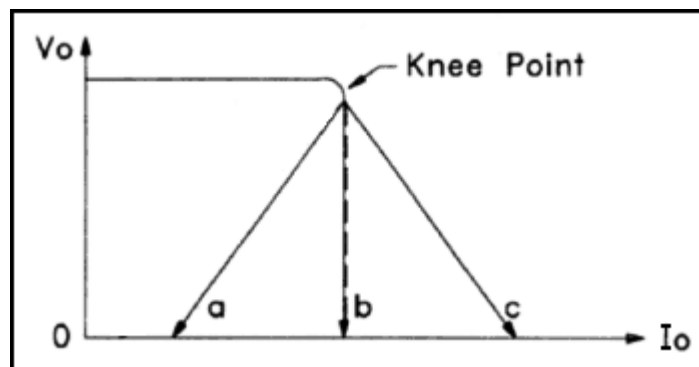

Fig. 4

Recovery Circuits

a. Automatic Recovery

Automatic Recovery senses the removal of the fault condition and returns the power supply to normal operation.

b. Manual Recovery

Before proceeding with Manual Recovery, make sure that the fault condition is removed. Manual Recovery requires cycling the input power or remote control off and on. A ten to thirty second wait is necessary before turning on again.

Overcurrent /Overload Precautions

Protection and Recovery circuits are designed to prevent damage to the power supply during an Overcurrent or Overload condition. However, leaving the power supply overloaded (or shorted) for extensive periods of time is NOT recommended and may result in reduced life and/or damage to the power supply.

2.3 OVER TEMPERATURE PROTECTION (OTP)

Some power supplies have an excessive temperature shut down circuit. When the power supply's operating temperature is too high the protection circuit will shut down the output. Some common causes of excessive temperature are Overcurrent/Overload, high ambient temperature or restricted ventilation (e.g. faulty cooling fan). Automatic or manual recovery can occur once the cause of the over temperature condition is removed (high ambient temperature and/or high load).

2.4 OVER VOLTAGE PROTECTION (OVP)

When the output voltage exceeds the rated value by approximately 130%, the power supply will be protected by the following two possible methods to prevent damage to the components at the load terminals:

- a. Shutdown the output voltage. Reset the power supply by turning it OFF for several seconds and then back ON again.
- b. Hiccup mode. The output will shutdown for a few seconds and then attempt to restart automatically.

Over Voltage Protection may be triggered by a fault within the power supply, most commonly by setting the output voltage trim pot too high or it can occur when an external voltage is applied to the output. Using an external voltage applied to the output terminals provides a simple means of testing the over voltage threshold of a power supply. Note, excessive voltage or reverse polarity voltages applied to the output terminals can damage a power supply!

There are two kinds of OVP:

- a. Disabling the control circuit controlling the feedback loop.
- b. Shorting the output by using a “Crowbar” activating the power supply’s overcurrent/overload protection.

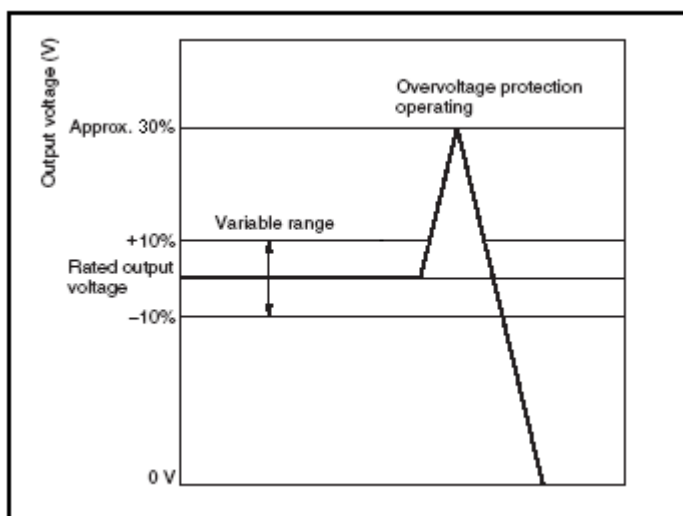

Fig. 5

3. INSTALLATION, WIRING AND OPERATION

Even the most efficient switching power supply will not function properly if the installation, wiring or connections are not correct. Follow the installation, wiring and connection instructions specified in the data sheet or manual before switching on any power supply. Also see the document ‘Power Supply Cables and Connectors’.

3.1 INSTALLATION

Heat Dissipation

- a. Ensure the unit is properly ventilated.
- b. Install the power supply in the correct position. Remember ‘hot air rises’ and ensure correct orientation.
- c. Ensure the unit has proper heat conduction and is not mounted near other heat sources.
- d. When you install two or more power supplies, leave additional space between them for cooling.
- e. Forcing air over the unit will improve heat dissipation.

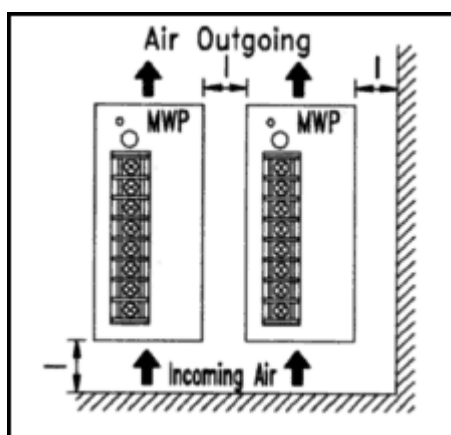

Fig. 6

When mounting any power supply please refer to any notes and temperature derating curves in the specifications. For example, with the SDR range the minimum installation clearances are: 40mm on top, 20mm on the bottom, 5mm on the left and right side unless the adjacent device is also a heat source then 15mm clearances are recommended.

Output Derating

Output power depends on operating temperature. Derate the output of the switching power supply according to the temperature derating curve shown in the specifications. The output power may also be derated with low input voltages.

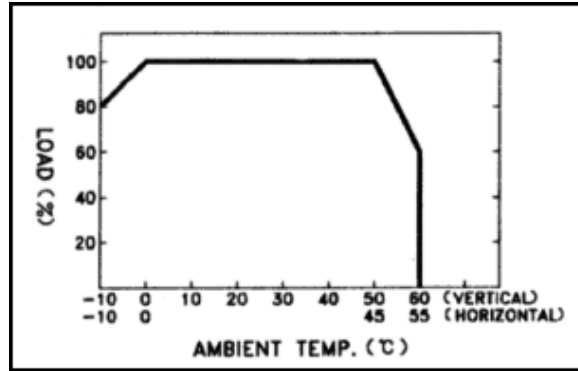

Fig. 7

Securing Screws

Always check the specified screw length and tightening torque when you attach the power supply to your equipment enclosure.

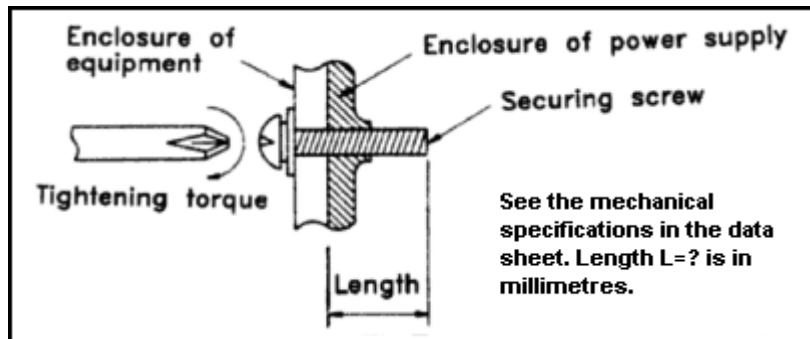

Fig. 8

3.2 WIRING AND OPERATION

Input and output wiring

- Separate the input and output wires so that any external surge voltage on the AC input lines does not interfere with the output side. This will insure that the output ripple and noise does not increase.
- Use short, thick wires on the output. Wire thickness will also depend on the current capacity required.
- When connecting wires to the switching power supply, use the appropriate terminal screws, solder-less terminals and tools.
- Be careful to prevent wire off-cuts or other objects entering the power supply. It is recommended that the power supply not be mounted until all work has been completed or the vents are covered until the power supply is ready to be operated.

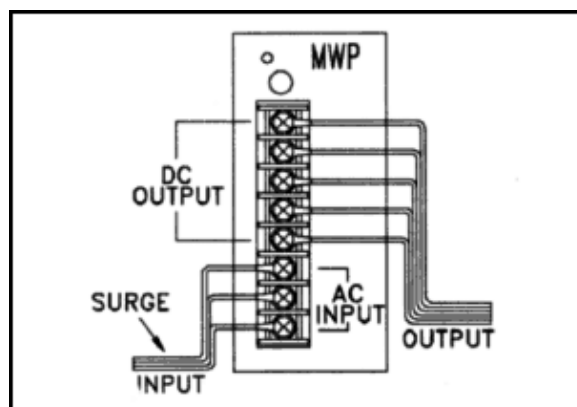

Fig. 9

Ground connection

Connect the ground terminal of the switching power supply to the frame of the equipment with regulation size and colour wire to ensure safety and to minimize noise and interference.

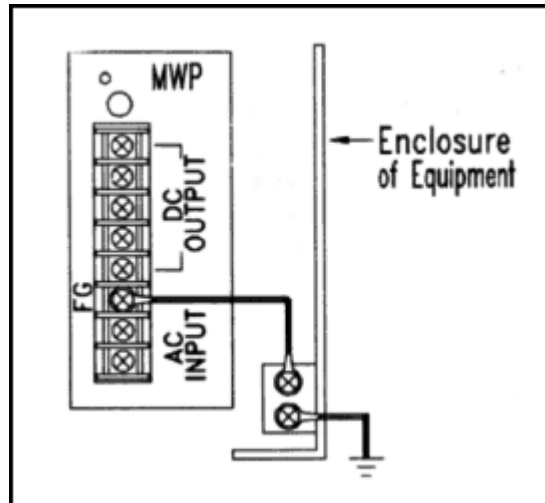

Fig. 10

Inrush Current Control

Mean Well switching power supplies have large capacitors incorporated in the input supply circuit. Consequently, there is a high inrush current when input power is applied (>20 amps @ 115 volts; >40 amps @ 230 volts). When using several power supplies in a single system, do NOT apply power to all of them simultaneously. Note: ten S-25 power supplies would draw an inrush current of >250 amps @ 230 volts. A preferred power application would be a "delayed power circuit". Another method of controlling the inrush current is to use different AC phase circuits.

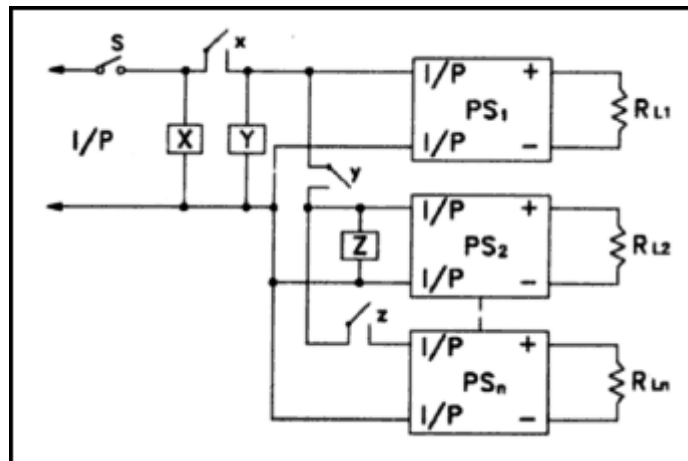

Fig. 11

Remote Control and Remote Voltage Sensing

a. Remote Control of the Output

The output of some power supplies can be controlled by supplying an appropriate signal to the +RC & -RC terminals. Normally a short-circuit (0 volts) will turn the power supply output on. An open-circuit (>4 volt) will turn the output off. These power supplies are shipped with a jumper across the +RC & -RC terminals. Always refer to the data sheet as some remote controlled power supplies use different control signals. Ask Procon Technology about remote switching modules (radio and IR) which can be used with power supplies such as the HRPG range. The auxiliary supply can be used to power the module!

b. Remote Voltage Sensing

Power Supplies equipped with a Remote Voltage Sense capability can detect a voltage drop at the load. This feature is especially useful when the power supply and the load are connected by a long line. Power supplies with the Remote Sense have +S and -S terminals (as shown in Fig. 12). When the +S and -S terminals are connected to the load side of the output, the power supply will be able to detect a voltage drop at the load. The power supply will raise the output until the correct voltage is provided at the load terminals. See the HRP(G) range for remote sensing for power supplies of 150W to 600W.

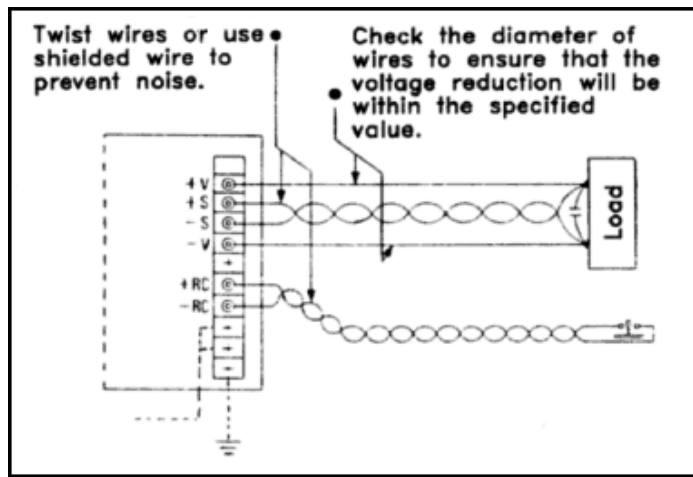

Fig. 12

Operation in Parallel

Power supplies are commonly used in parallel to increase the output current. Mean Well's PSP, RSP and RCP Series are designed for parallel use. The SDR-480P, HRP6-600 and the SPV-1500 models can also be used in parallel. These power supplies have a Parallel "P" or Current Share "CS" terminal that is designed to sense other power supplies connected in parallel. This circuit controls the output voltage and allows a more efficient operation of each supply (sharing the load current equally).

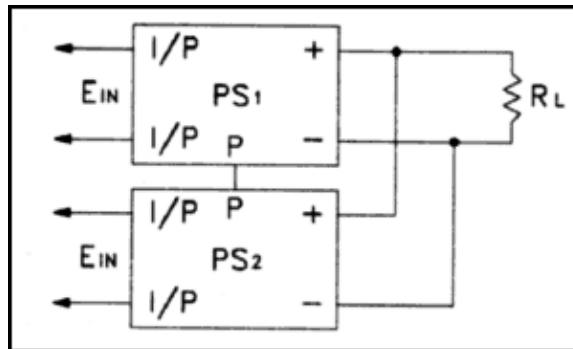

Fig. 13

Notes on parallel operation:

- Always use the same model type and voltage in any parallel configuration.
- Output voltage of each power supply should be the same (tolerance +/- 2%).
- Each power supply should be wired together with short and thick wiring first and then connected to the load.
- The total output current should not exceed 90% of the total current from all power supplies.
- Always check the specifications for the required connections, restrictions on the number of parallel units that can be used, minimum load requirements and connecting the sense terminals (+S and -S) or other features (e.g. remote control).

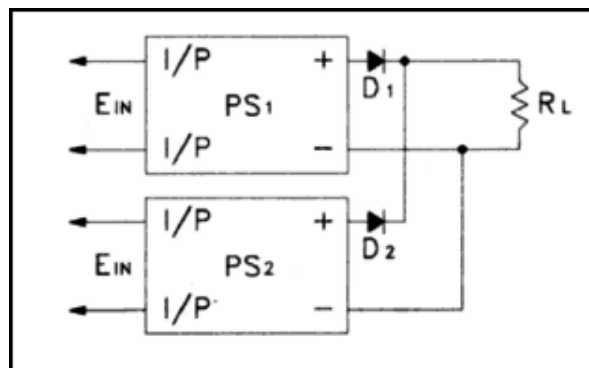

Fig. 14

Figure 14 illustrates a method of paralleling other types of power supplies for redundant use - increasing the reliability of a system. Diodes are connected to the positive side of each power supply. This connection is only for use in redundant systems and allows the system to continue to operate even when one power supply fails. e.g. see the DR-RDN20 module.

Operation in Series

Power supplies are often connected in series to produce higher voltages. Two types of series connections are described below. For series operation all power supplies require 'floating' or un-earthed outputs!

a. Fig. 15 describes a sample set up for separate distinctive loads. Protective diodes (D1 and D2 below) may be necessary with this type of application to protect the power supplies if connection X is lost.

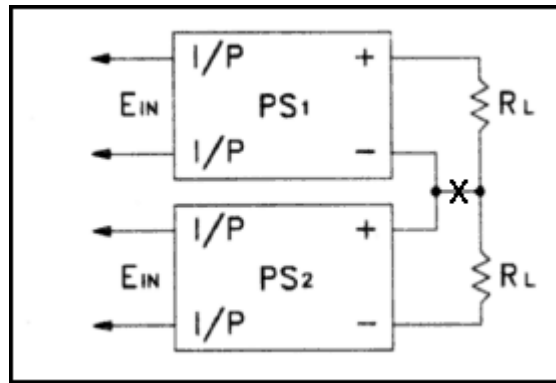

Fig. 15

b. Fig. 16 illustrates a sample set up for series connected power supplies. The diode, connected directly across the output terminals, is also recommended in any application where a reverse voltage may be applied to the power supply's output. As a general guide, the diodes should be Schottky Barrier with a reverse voltage more than twice the output voltage and rated output current more than twice the rated output current or short-circuit current whichever is greater.

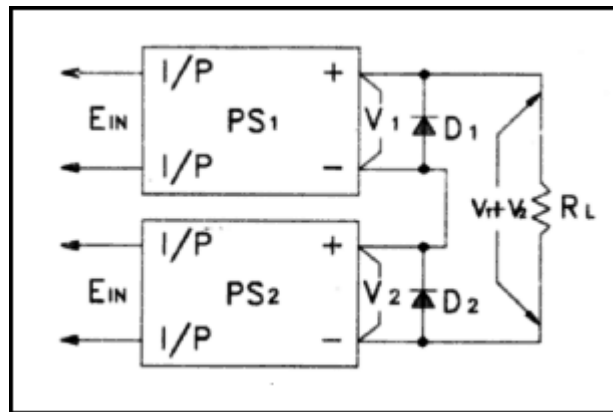

Fig. 16

Additional Output Ripple and Noise Control

Fig. 17 is a diagram of a sample circuit that will improve the output ripple, noise, and Electromagnetic Interference (EMI) or Common Mode Noise. Fig. 17 is an example circuit only. Further design considerations are essential for specific applications.

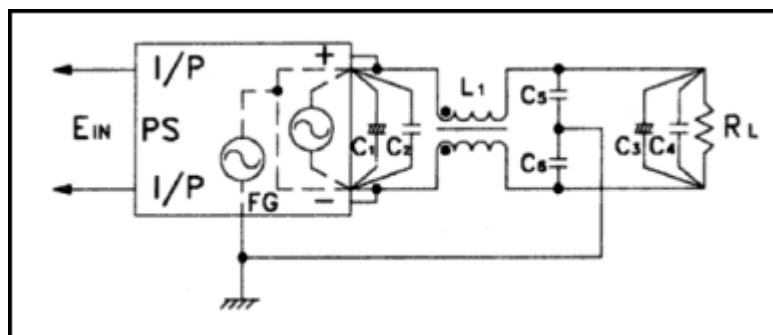

Fig. 17

Note: C1 & C3 are electrolytic capacitors and control the output ripple. Their values should be between 47 μ f and 100 μ f. C2, C4 & C5, C6 are high frequency ceramic capacitors and reduce the output noise. Their values range from 0.01 μ f and 0.1 μ f. The value of inductance L1 is 0.5 μ H to 5 μ H.

Minimum Load Requirement

Multiple output power supplies are calibrated and fully regulated on Channel 1 (known as the master channel) of the unit. Channel 2 and higher are quasi regulated from Channel 1. If Channel 1 is not used, the output voltages of the other channels may be out of tolerance. Therefore, a minimum load on Channel 1 is recommended as a calibration factor.

Example: A Mean Well D-120B (dual output) power supply was connected in a circuit. The specifications for this unit are as follows.

Channel	Output Voltage	Tolerance	Output Rated Current	Output Current Range
1	5V	±2%	6A	2A - 10A
2	24V	±7%	4A	0.4A - 4A

A 4 amp load was connected to Ch. 2 and no load was connected to Ch. 1. The Ch. 2 output voltage was ~23 volts. Then a 2 amp load was then applied to the 5 volt output and the Ch. 2 voltage rose to ~24 volts.

Another test was conducted with a 6 amp load on Ch. 1 and no load on Ch. 2. The Ch. 2 output voltage was ~26 volts. A 0.4 amp load was then connected to Ch. 2 and the Ch.2 output voltage dropped back down to ~24 volts.

Surge Voltage Control

Fig.18 shows a circuit used to control voltage surges that may be caused by power fluctuations or stray surges due to lightning. The circuit has varistors connected between AC/L - AC/N, AC/L - FG, and AC/N - FG. This type of circuit is recommended in areas where there are frequent lightning strikes. Further input conditioning including an Uninterruptable Power Supply (UPS) may be considered in areas where there are frequent power fluctuations or power failures.

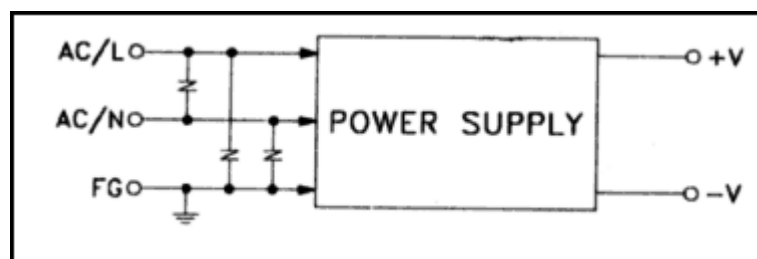

Fig. 18

Low Temperature Environments

Mean Well Power Supplies use a thermistor that limits inrush current under cold start conditions. In low temperature environments the thermistor resistance is high. The input current may be too low for the power supply to function. (This usually occurs under minus 10°C). Use the procedure below when first applying the input power during cold climate conditions.

- Operate the power supply continuously (do not power it down) and use the Remote Control input or an external switch, relay or contactor to activate and de-activate the output voltage.
- If the power supply does not start-up, decrease the load on the output until the power supply is fully operational. Start-up may take much longer than normal as the in-rush current limiting device (a thermistor) may need to warm-up.
- If the power supply is in an environment that is frequently cold, install a heat producing device near the power supply case (such as a large resistor, a lamp or a heating unit).

Note, in low temperature applications choose a switching power supply from the HRP/G range which operates down to minus 30°C or the SDR range (DIN rail mounted) which operates down to minus 25°C.

Charger Use

When a power supply is used as a lead-acid battery charger, a parallel and a series diode and a fuse (or circuit breaker) should be installed at the output. These components will protect the unit if the battery voltage is higher than the power supply. These components will also protect the unit if a reversed polarity situation occurs. Contact your supplier, for more information, should you wish to use any power supply for battery charging. You should use a unit designed for charging where possible as these protection devices are often built-in and the charge techniques used are designed to lengthen the battery life.

4. SAFETY

Generally speaking, switching power supplies are manufactured to produce a stabilized DC supply. Power supplies with exposed terminals are designed for integration into other equipment. Such power supplies must not be used until incorporated into a suitable enclosure as required by local laws and regulations. Please consult the relevant authority.

Electric Shock

High voltages are present inside the power supply (which can be 2 - 4 times the input voltage). Do NOT attempt to repair the unit or remove the power supply's cover. If the power supply needs service or repair return it to Mean Well or an authorized Mean Well repair centre. When the power supply is installed in a system, be sure that the case is properly grounded. Some Mean Well Power Supplies are 'Open Frame' and supplied without a case. Use extreme caution when touching or removing these units for repair. Appropriate safety equipment and procedures must be used when touching or removing the power supply.

High Operating Temperatures

When the power supply is operating at full output, internal component temperatures may exceed 100°C. Do NOT touch any components inside the power supply case. The external case temperature may also be at a point where it is unsafe to touch.

Keep all flammable, explosive, and volatile materials away from the power supply.

Rated Input Voltage

The input voltage of the switching power supply is limited. It can be dangerous to apply voltage which is outside of its specified range, damage may occur to the power supply. Always use the power supply within its specified input voltage range. Always check the position of any AC input range switch before applying power.

Leakage Current

The internal noise filter capacitors generate a leakage current within the range specified by the safety standards of each country. However, if two or more power supplies are used, the leakage current increases and electrical shock may occur. Take measures such as securely grounding the unit, to prevent electric shock.

Wiring Materials

To prevent wiring materials from heating up or igniting, use the correct gauge of wire which can withstand the output current capacity of the switching power supply. Also, check the rated voltage of any wire used.

Shared Usage

It is particularly important to be careful when the current is diverted for use by a low current load. If a thin wire is used as a branch line, the overcurrent/overload protection circuit may not work if the load is short-circuit. To ensure safety, attach a suitably rated fuse, circuit-breaker or other protection device (resettable fuse or polyswitch) to the low-current wire as shown in Fig. 19. Remember, overloading of circuits beyond their capacity causes overheating of cables and conductors, and can result in direct fire hazards or, more often, in damage to insulation with the development of arcing or sparking.

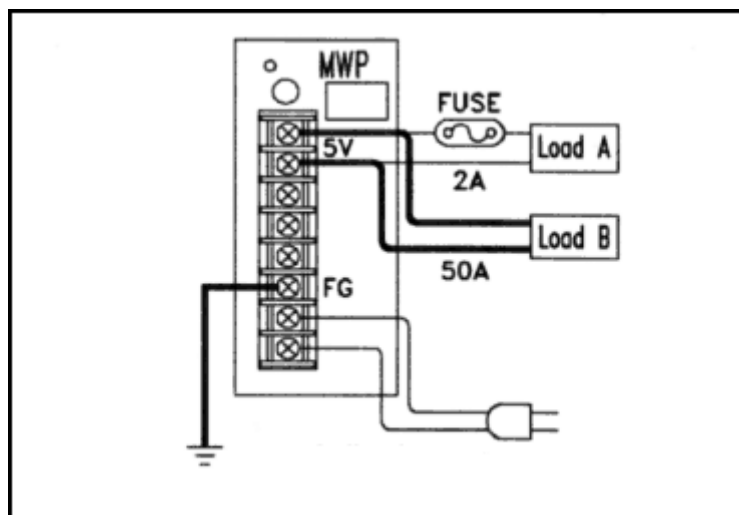
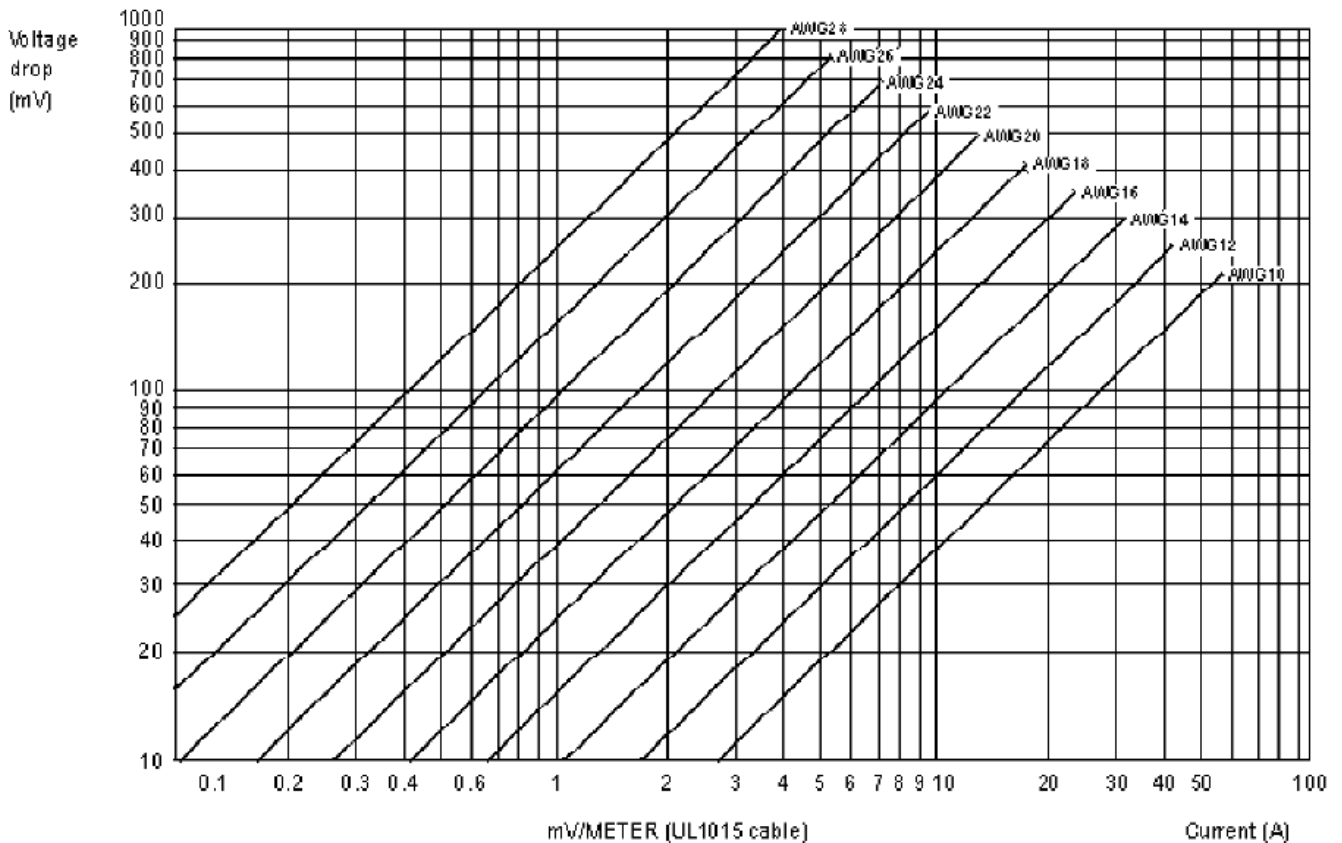

Fig. 19

Connection Cable Material

The tables below contain a selection of UL approved connection wire. These tables should be reviewed when selecting cable for the input and output sides of the power supply.

AWG No.	DIA (mm ²)	INSTRUCTION	PER A mV/m	MAX. CURRENT (A)	
				UL1007 (300V 80°C)	UL1015 (600V 80°C)
30	0.051	7/0.102	358	0.12	-----
28	0.081	7/0.127	222	0.15	0.2
26	0.129	7/0.16	140	0.35	0.5
24	0.205	11/0.16	88.9	0.7	1.0
22	0.326	17/0.16	57.5	1.4	2.0
20	0.517	26/0.16	37.6	2.8	4.0
18	0.823	43/0.16	22.8	4.2	6.0
16	1.309	54/0.18	14.9	5.6	8.0
14	2.081	41/0.26	9.5	-----	12.0
12	3.309	65/0.26	6.0	-----	22.0
10	5.262	104/0.26	3.8	-----	35.0



Ground Wire

Connect the grounding terminal of the power supply to the frame of the equipment with a short, thick wire.

Note: For switching power supplies integrated into other equipment, safety standards differ from country to country. Check the standards (specifications) listed in documents provided by your supplier or relevant government agency when you use a switching power supply inside your own equipment.

5. EMI

Switching power supplies are manufactured to comply with electro-magnetic interference (EMI) standards (refer to relevant specification). Depending on the wiring of the power supply, load and grounding, the power supply may not function correctly. To ensure optimal use of power supplies, consider the following steps:

a. Separate Input and Output Wires

If the input and output wires are too close to each other, induced noise on the output terminal increases. Typically, if the noise terminal voltage of the input line increases, noise radiation (noise field intensity) from the equipment increases. Also, if the input line and the internal circuits (digital circuits, in particular) of the equipment are too close to each other, the noise terminal voltage increases and the equipment may not operate properly. Make sure that the input line is separated from any low voltage internal circuits of the equipment.

b. Short, Thick Wires

Input and output wires on the equipment should be short and thick. Each set of two wires should either be attached or bundled in parallel or twisted together. If wires are looped, the noise and interference from the power supply will be affected.

6. RELIABILITY

6.1 LIFE CYCLE AND BREAKDOWN

Switching power supplies have proven to be highly reliable when used in household appliances and industrial products and are highly rated throughout industry.

The following figure shows the failure rate curve (bathtub curve) during a typical product life cycle.

The Early Failure Period - to prevent early failure, each manufacturer screens out parts or performs aging tests on the finished product. When Mean Well switching power supplies are delivered to customers, the power supplies have already entered the random failure period.

Random Failure Period - the stability of each switching power supply depends on its own reliability (Mean Time Between Failure: MTBF).

Basically, the failure rate is very low. However, the failure rate in the random failure period differs depending on installation and operating conditions (ambient temperature, installation method, derating, ventilation, vibration and shock) which are determined by the user.

Fatigue Failure Period - At some time, the switching power supply will enter the fatigue failure period.

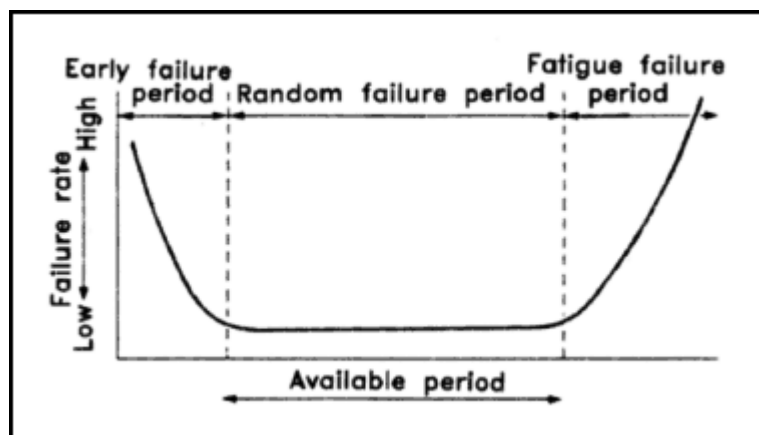

Fig. 20

6.2 AMBIENT TEMPERATURE AND SERVICE LIFE

High efficiency switching at a high frequency, improvement in parts and integration technology has greatly reduced the size of switching power supplies. Integration density has allowed the internal parts to be packed closer together.

Each part of a switching power supply distinctly differs in its service life depending on the ambient temperature.

An electrolytic capacitor used as a smoothing filter is more sensitive to variations in the ambient temperature because of the chemical reactions which occur within it.

Typically, the service life of electrolytic capacitors halves for every ambient temperature increase of 10°C. This characteristic determines the service life of most Mean Well switching power supplies.

Fig. 21 shows the relationship between the service life of the switching power supply and ambient temperature. If the switching power supply is used at high temperatures, the electrolytic capacitor may enter the fatigue failure period while the other parts are still in the random failure period. To increase the service life of the switching power supply, it may be necessary to replace some electrolytic capacitors.

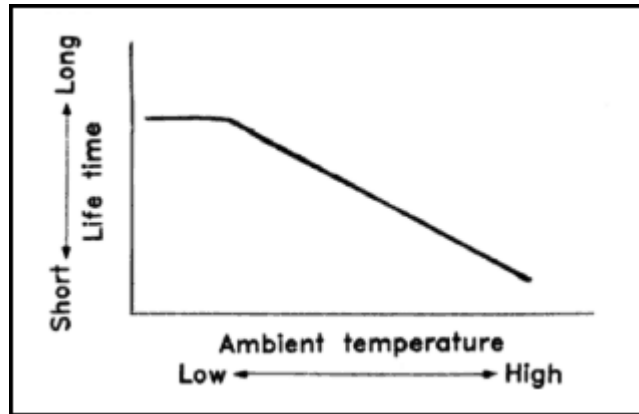

Fig. 21

6.3 OVERHAUL

As technology improves, the number of continuous operating systems increases. And though the service life of switching power supplies is also increasing, they cannot be relied upon forever.

Therefore, periodic overhauls are required to ensure the reliability of any equipment. How often an overhaul needs to be performed on a power supply depends on the operating conditions and temperature. Service life is most seriously affected when a power supply is operated continuously. In this case, the frequency of overhauls to the power supply should be as follows:

Ta is between 40°C and 45°C - once every three years

Ta is between 35°C and 40°C - once every four years

Ta is between 30°C and 35°C - once every five years

Where: Ta indicates the ambient temperature of the power supply

The above temperature values may differ depending on the type of switching power supply used. For more details on overhauls and service life, contact the manufacturer.

6.4 LOAD CAPACITY AND AMBIENT TEMPERATURE

A power supply's operating temperature depends on output load, ambient temperature, and cooling. The most ideal way to increase the service life of a power supply is to NOT continuously operate it at full capacity. This becomes even more critical in warmer climates or conditions.

Example: Two identical power supplies (subjected to the same environmental conditions) were operated using different loads. One had a 40% load condition and the other had an 80% load condition. The test showed that the power supply with the 40% load lasted four times longer than the power supply with the 80% load condition.

Every new model of the Mean Well Power Supply range is subjected to an environmental test during the prototype phase. Fig. 22 on the next page shows how temperature probes are connected to the Switching Power Supply (SPS). Figures 23 and 24 show the typical rise in temperature for each of the temperature probes with increasing load for two different models.

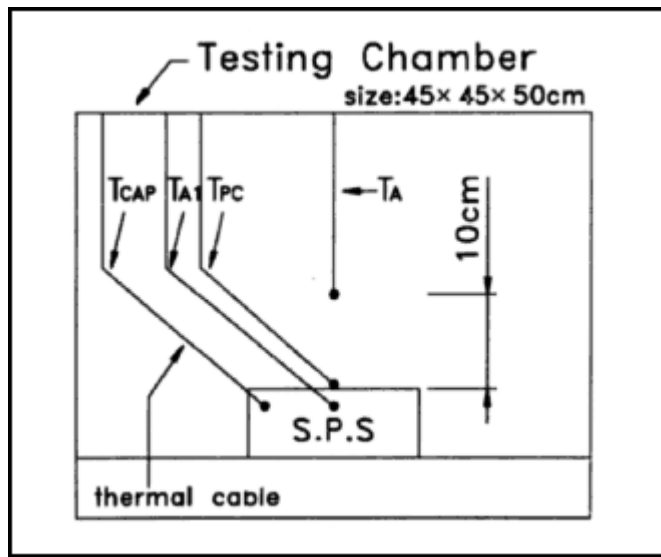

Fig. 22

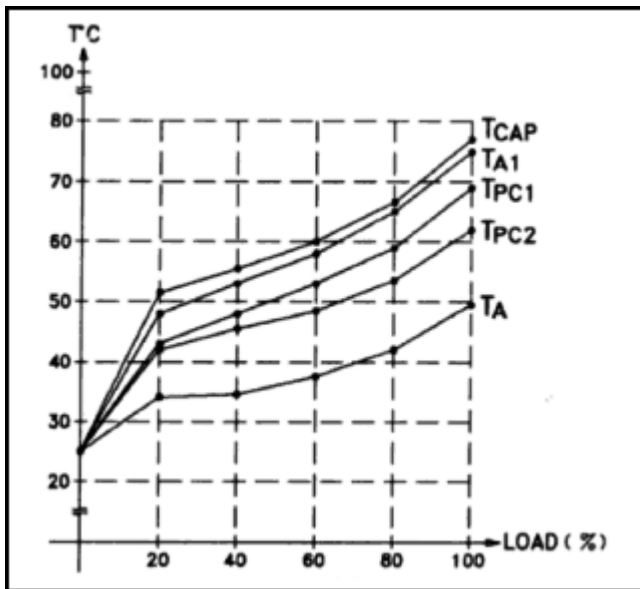

Fig. 23

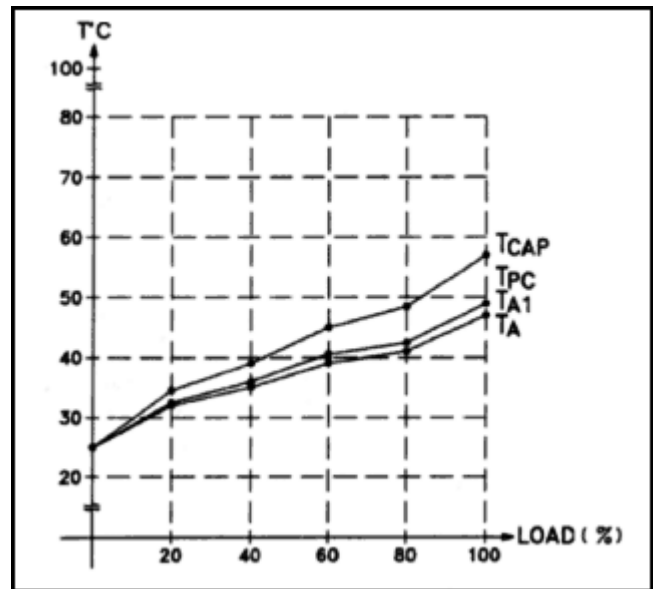

Fig. 24

Where:

- TA: Temperature inside chamber
- TA1: Temperature inside power supply
- TPC: Temperature of power supply case
- TCAP: Temperature of output capacitor

IMPORTANT NOTE

This summary of information is provided by Procon Technology and is largely from the Mean Well Switching Power Supply Technical Manual (September, 2003). Any circuit diagrams or assembly diagrams provided herein are for reference purposes only. It is provided in good faith but without any warranty or guarantee as to fitness to purpose. It is solely left to the discretion of the user as to the suitability of this information for their application.

We strongly advise all customers to contact us for advice on the most suitable power supply for their needs. It is especially important that the correct power supply is used, and protective circuits are installed, when driving heavily inductive or capacitive loads including motors, DC to DC converters and other loads with high inrush current such as lamps. Please follow all instructions regarding power supplies in parallel or series or used for charging batteries.

Please contact Procon Technology for a CD-ROM copy of the complete 110 page Switching Power Supply Technical Manual and for all your industrial, LED lighting power supply, charger, DC-DC converter and DC-AC inverter needs. Procon Technology also provides desk-top or laboratory power supplies from Manson Engineering.

Procon Technology, PO Box 655, Mount Waverley, VIC 3149, AUSTRALIA. Phone: 03-98306288 Fax: 03-98306481