

Production			
ATMEL Nantes SA La Chanterrie BP 70602 44306 Nantes Cedex 3 FRANCE			
Title		EVK1104	
Size	Document Number	Processor	Rev
A4			3
Date:	Friday, October 31, 2008	Sheet	1 of 12

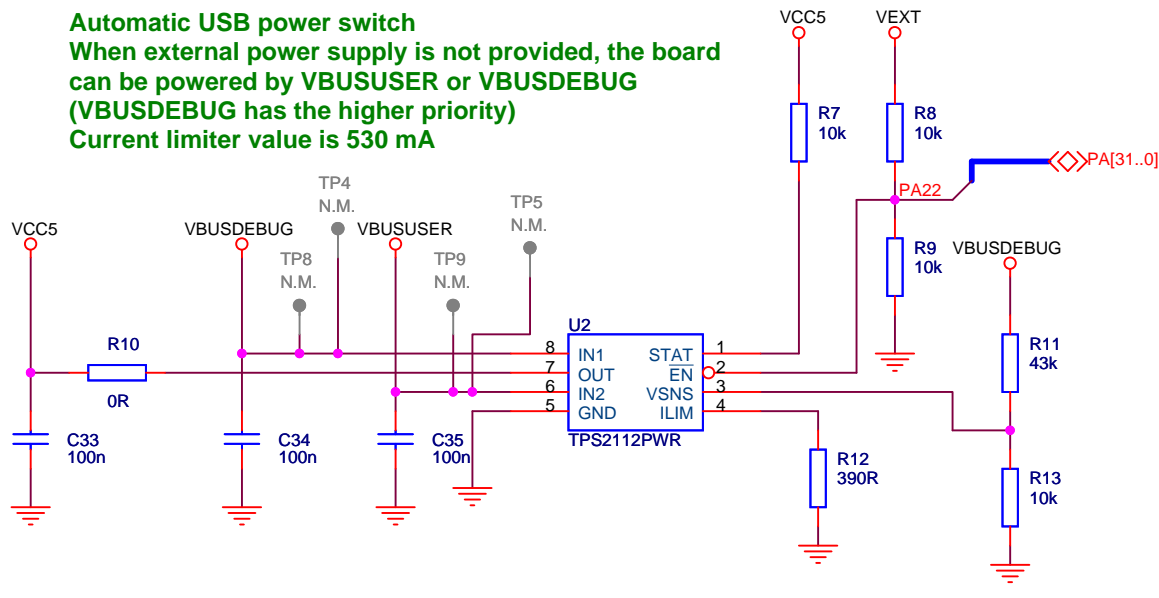

Automatic USB power switch
 When external power supply is not provided, the board can be powered by VBUSUSER or VBUSDEBUG (VBUSDEBUG has the higher priority)
 Current limiter value is 530 mA



External Power Supply (DC +5V +/- 10%)
 If applied, automatic USB power switch is disabled

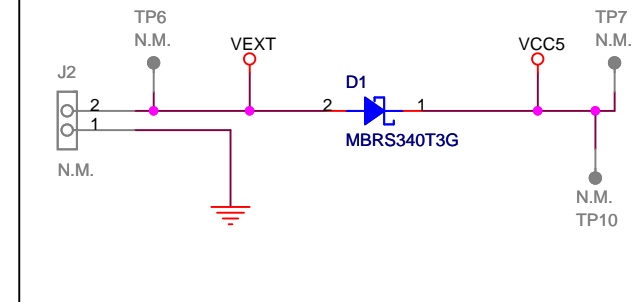

5V to 3,3V 1.2 A buck converter.
 $VCC3REG = 0.5 * (1 + 560k/100k) = 3,3V$
 All on-board components are powered by 3,3V
 (Only LCD back light is powered by VCC5)

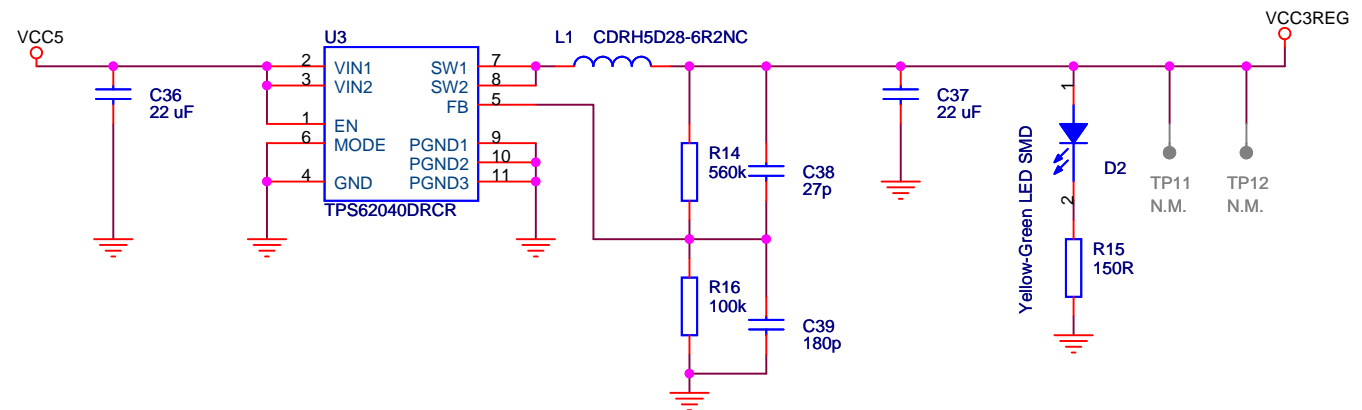

Power distribution

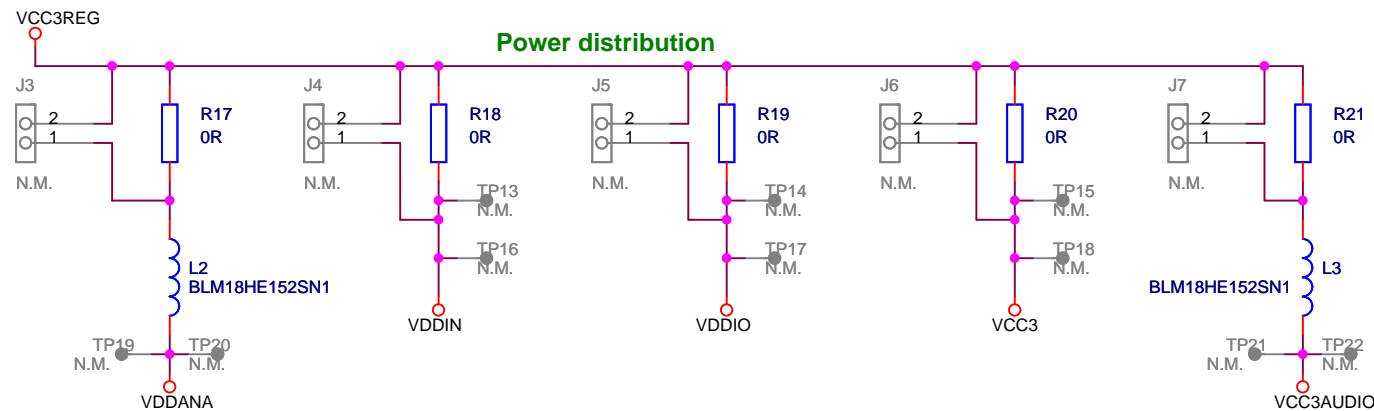

Production

ATMEL Nantes SA
 La Chantrerie BP 70602
 44306 Nantes Cedex 3
 FRANCE



Title		EVK1104	
Size	Document Number	Rev	
A4	Power supply	3	
Date:	Friday, October 31, 2008	Sheet	2 of 12

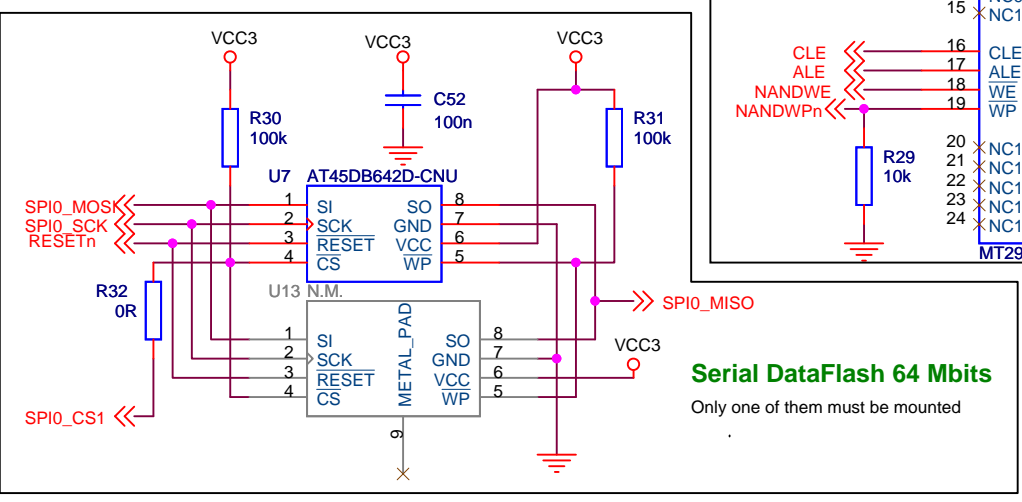
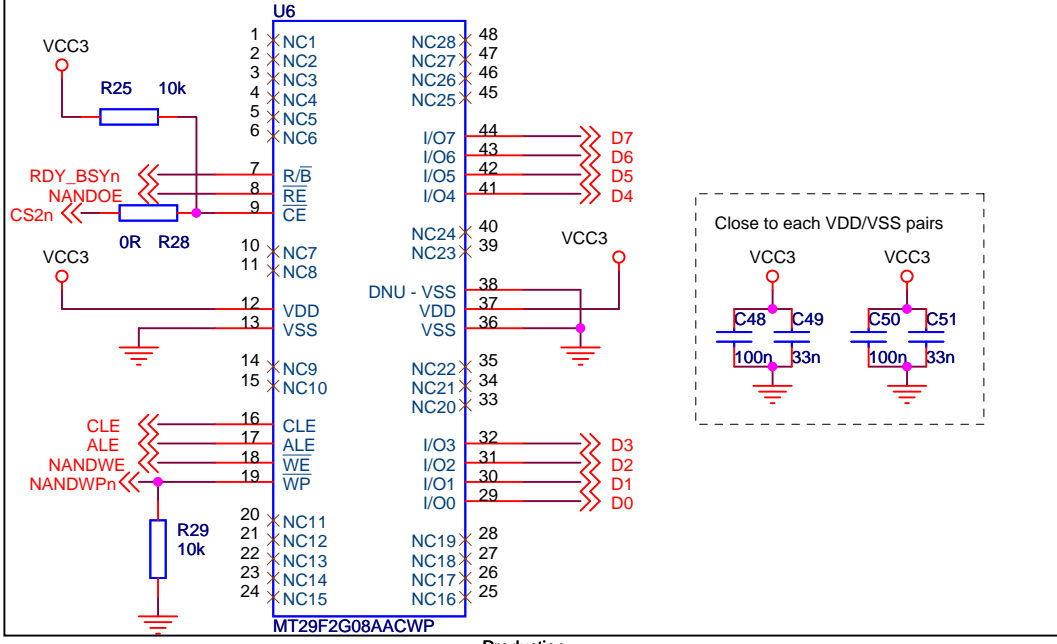
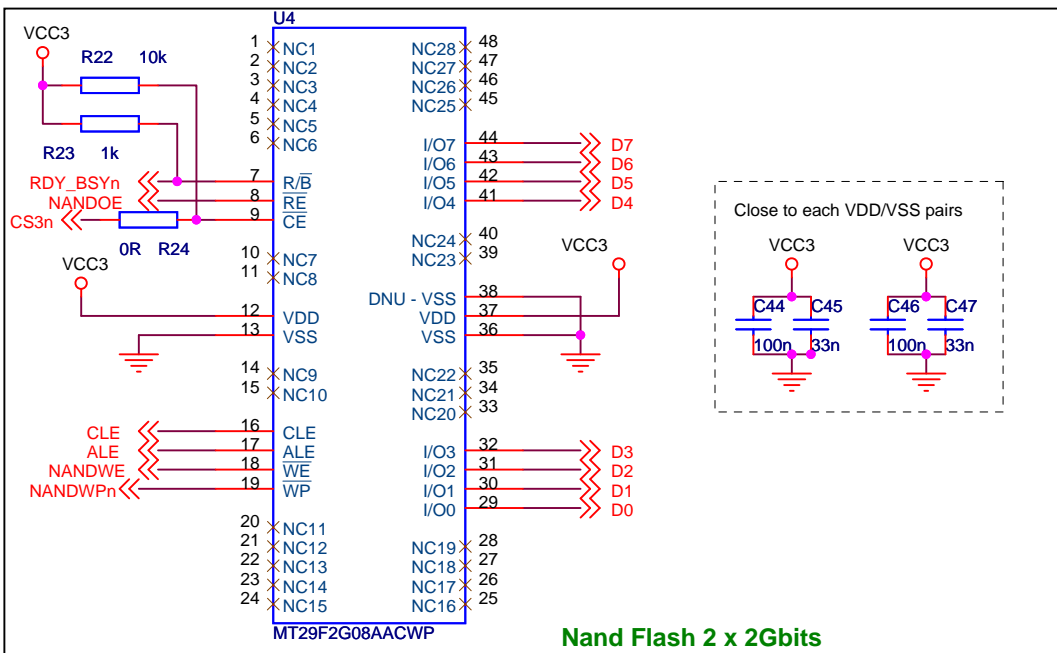
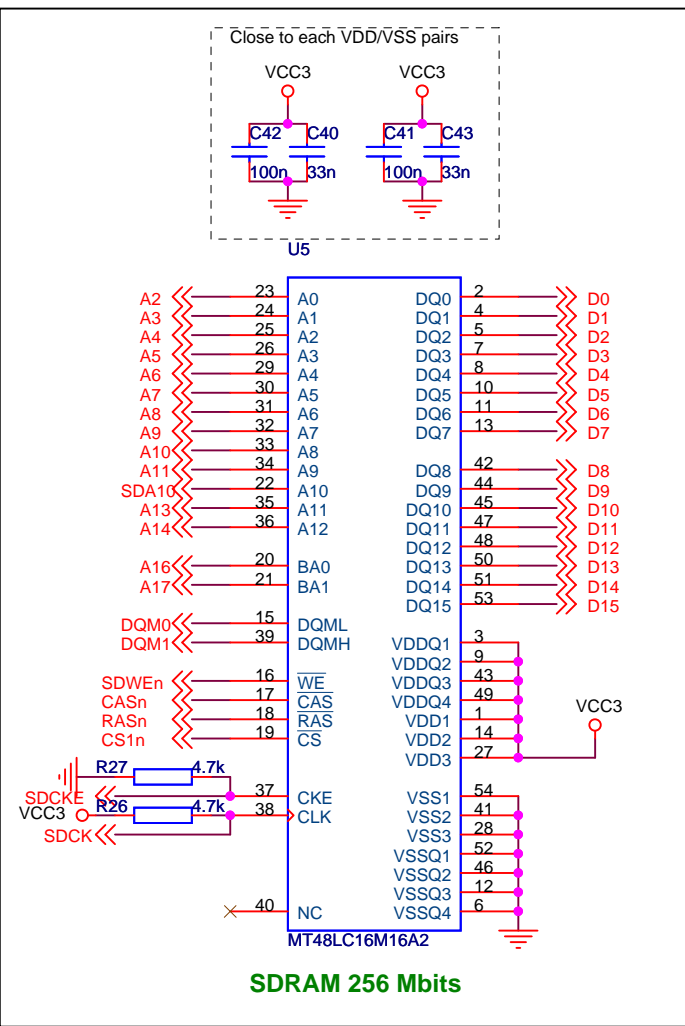
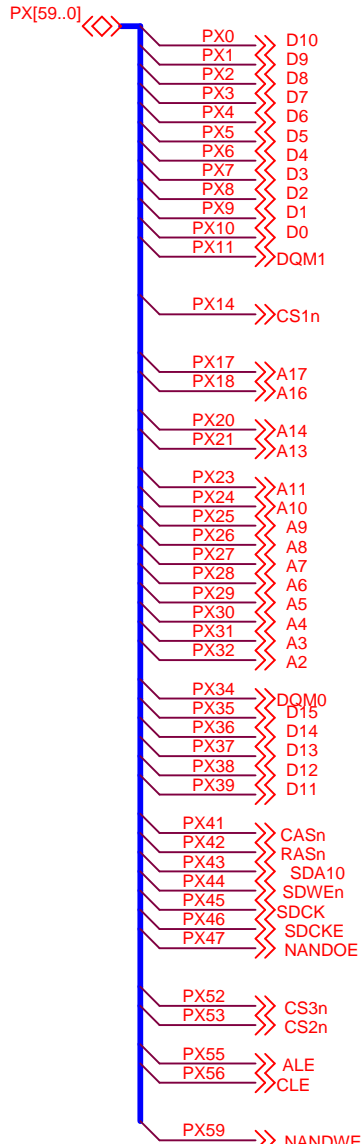

Production

ATMEL Nantes SA
La Chanterie BP 70602
44306 Nantes Cedex 3
FRANCE

ATMEL

Title		EVK1104	
Size	Document Number	Memories	
A4			Rev 3
Date:	Friday, October 31, 2008	Sheet	3 of 12

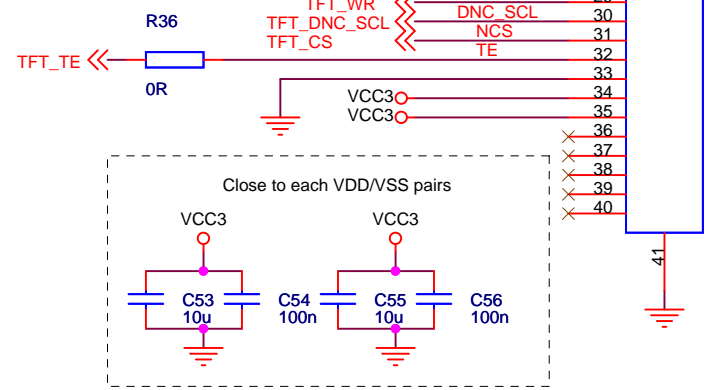
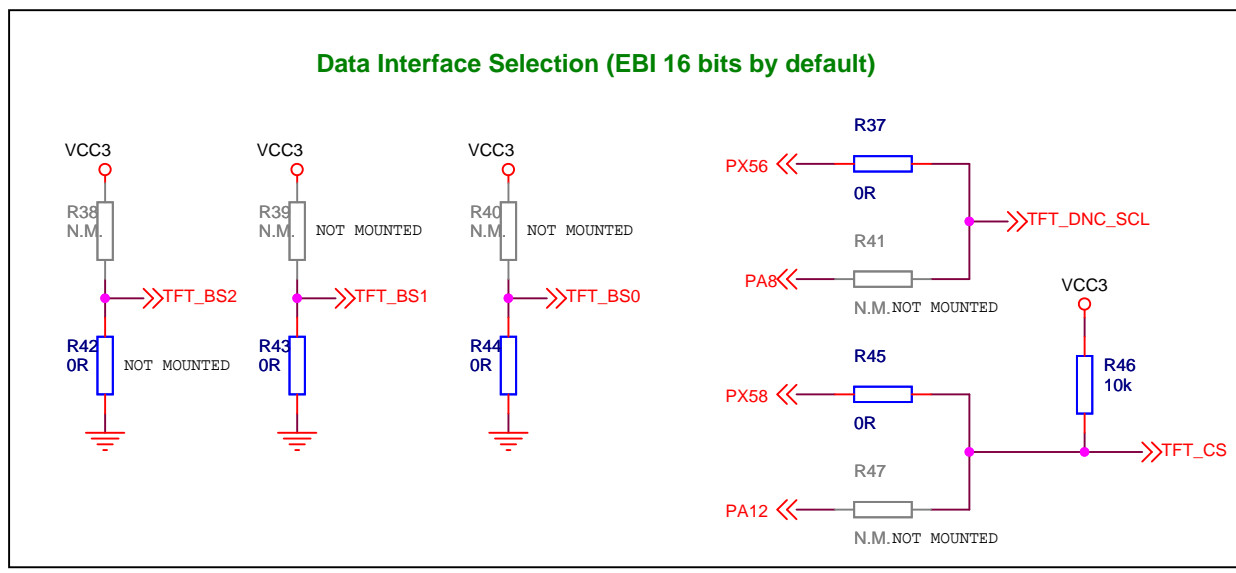
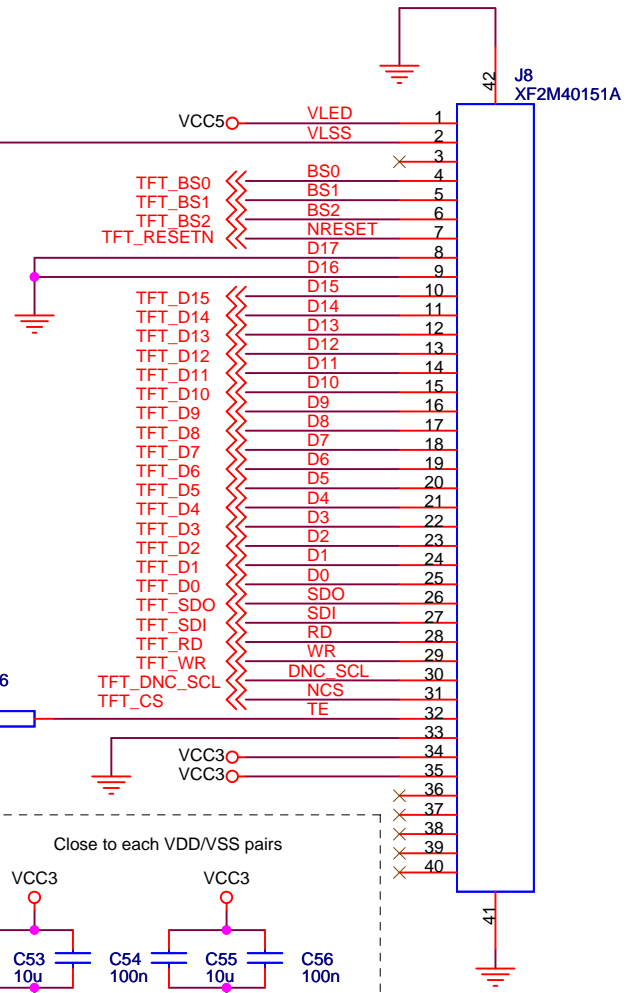
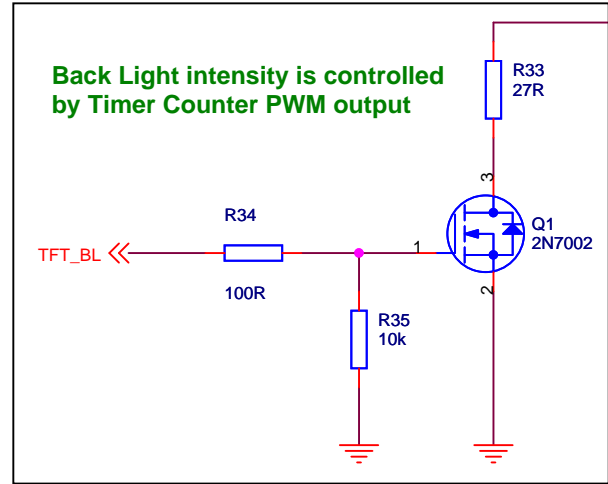
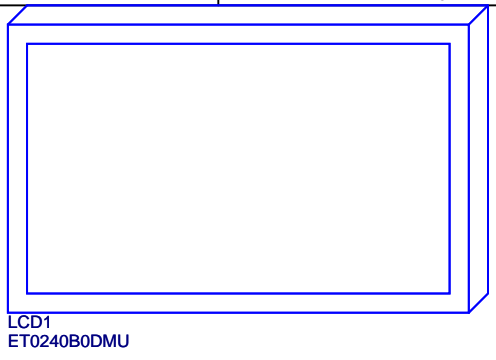
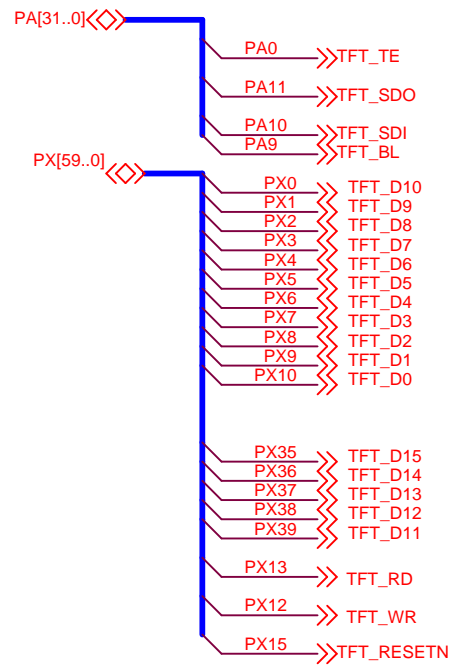

Production

ATMEL Nantes SA La Chantrerie BP 70602 44306 Nantes Cedex 3 FRANCE			
Title	EVK1104		
Size	Document Number	Rev	
A4	Lcd	3	
Date:	Friday, October 31, 2008	Sheet	4 of 12

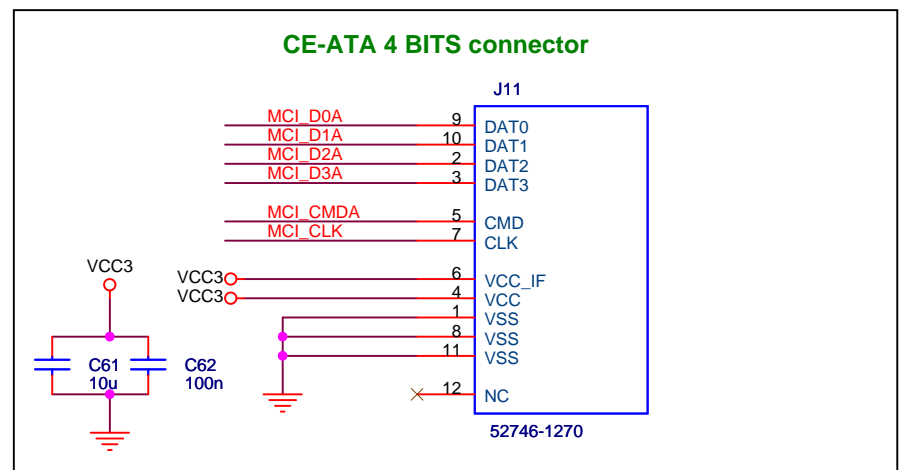
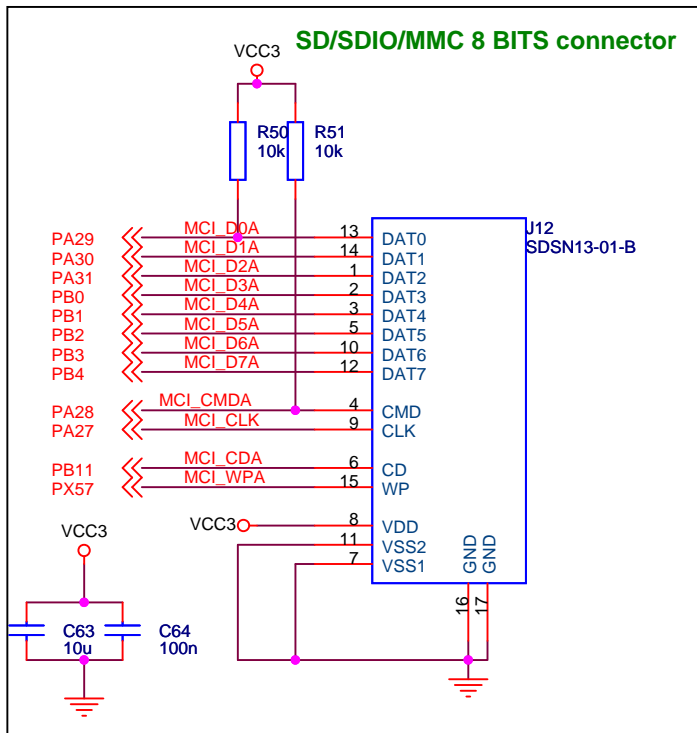
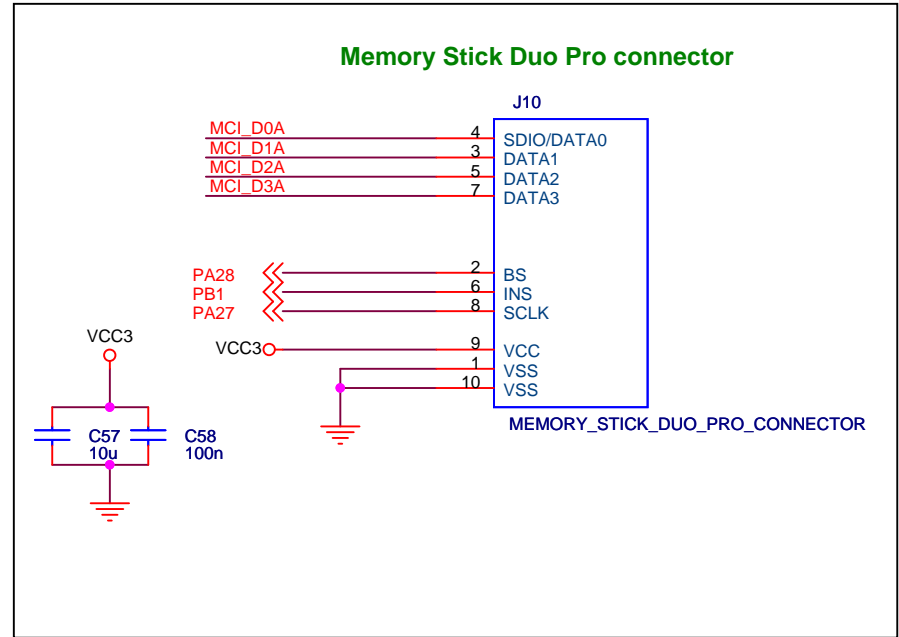
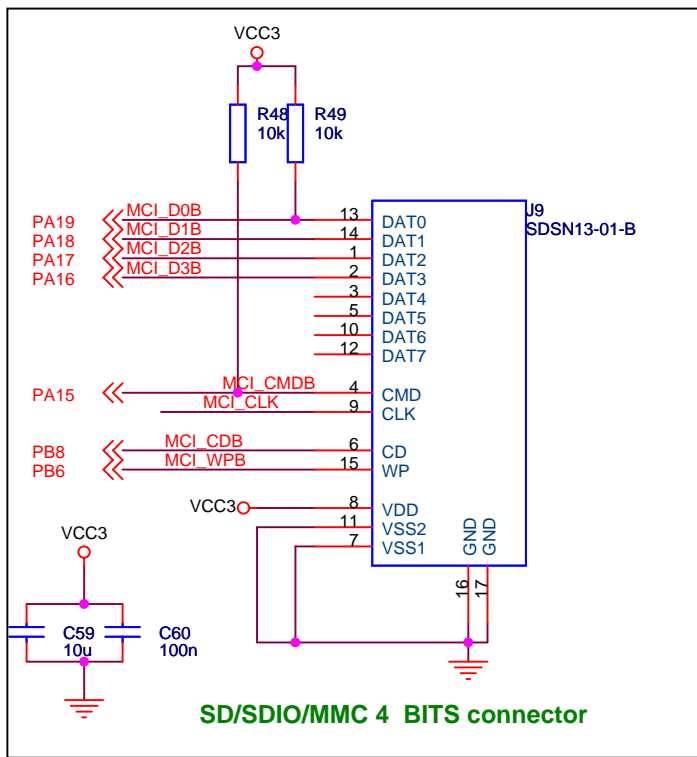

Production

ATMEL Nantes SA
 La Chantrerie BP 70602
 44306 Nantes Cedex 3
 FRANCE



Title		EVK1104	
Size	Document Number	Memory Cards	
A4			Rev 3
Date:	Friday, October 31, 2008	Sheet	5 of 12

Qwheel and 4 Qtouch emulated with a Qmatrix IC

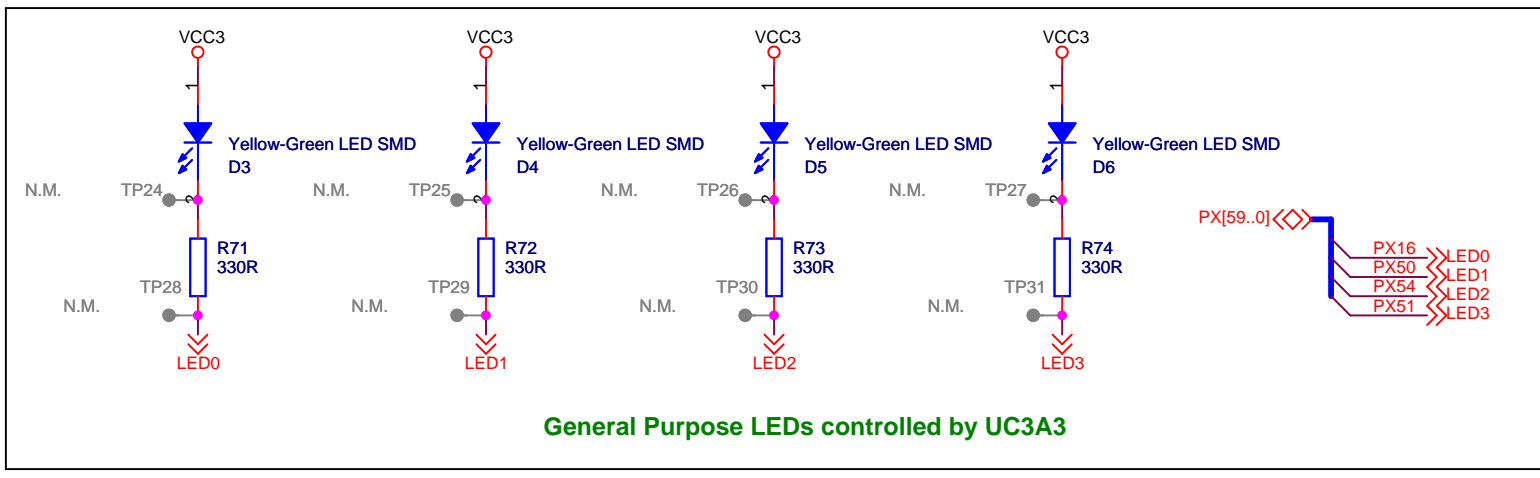
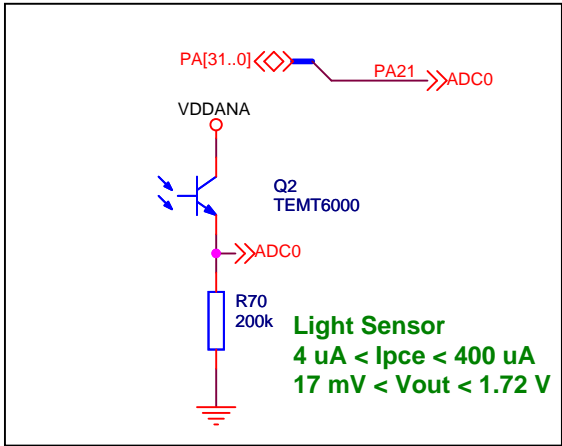
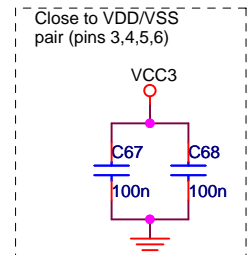
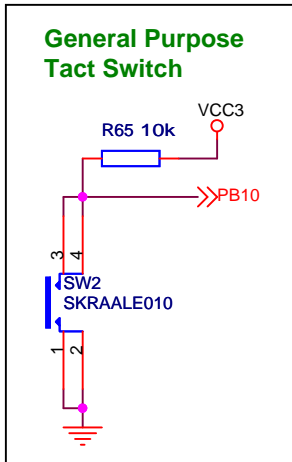
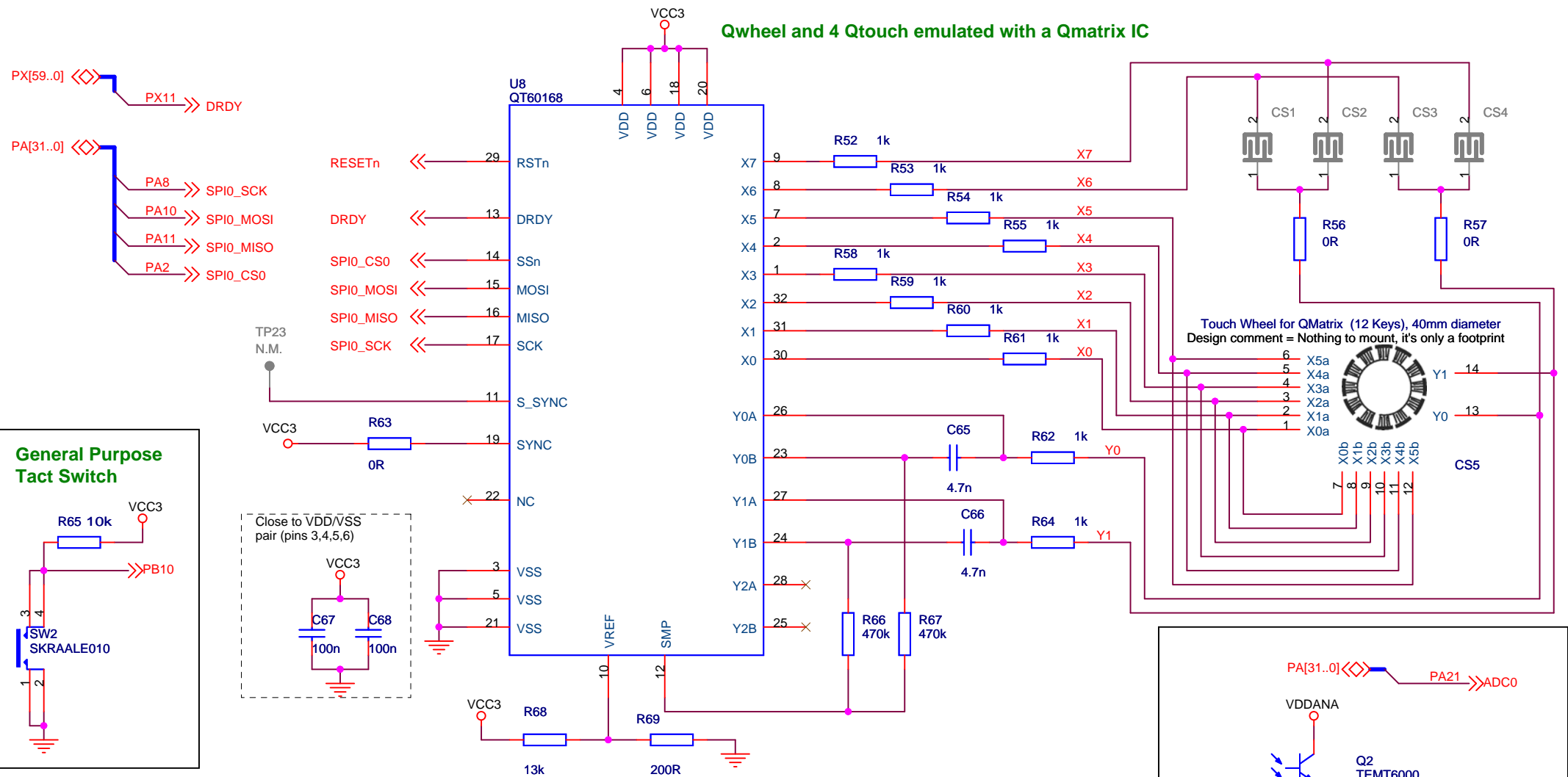

Production

ATMEL Nantes SA
La Chantrerie BP 70602
44306 Nantes Cedex 3
FRANCE

ATMEL

Title EVK1104		Rev 3
Size A4	Document Number Sensors	
Date: Friday, October 31, 2008	Sheet 6 of 12	

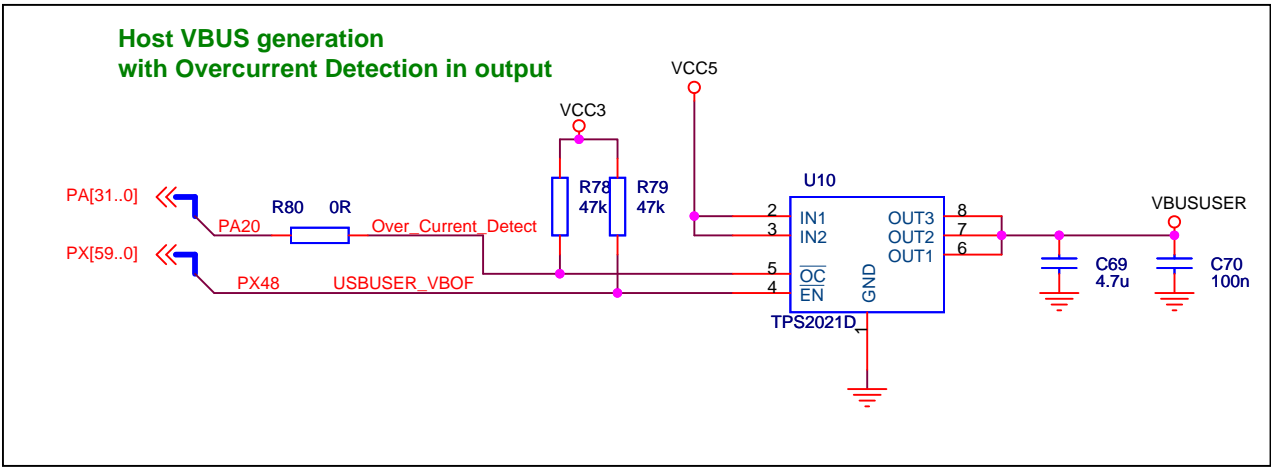
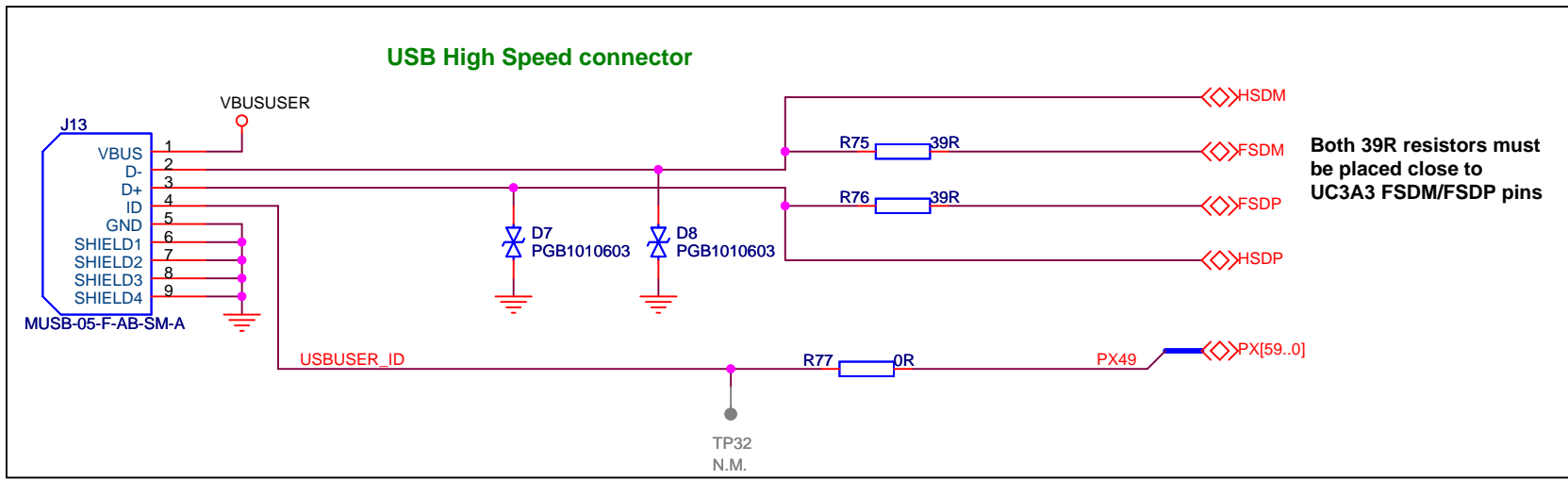

Production		
ATMEL Nantes SA La Chantrerie BP 70602 44306 Nantes Cedex 3 FRANCE		ATMEL
Title	EVK1104	
Size	Document Number	Rev
A4	USB High Speed	3
Date:	Friday, October 31, 2008	Sheet 7 of 12

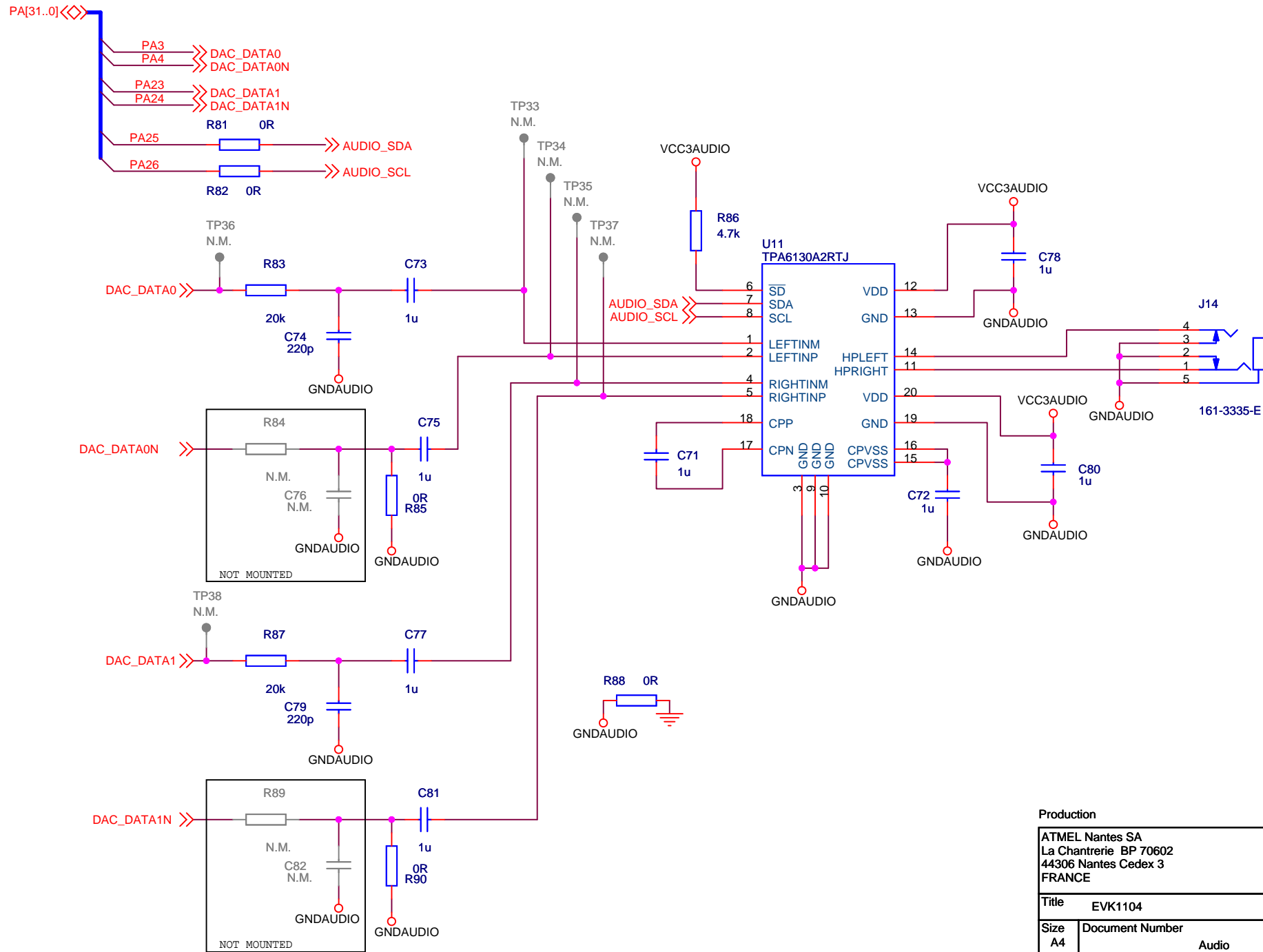

Production

ATMEL Nantes SA
 La Chantrerie BP 70602
 44306 Nantes Cedex 3
 FRANCE



Title		EVK1104	
Size	Document Number	Rev	
A4	Audio	3	
Date:	Friday, October 31, 2008	Sheet	8 of 12

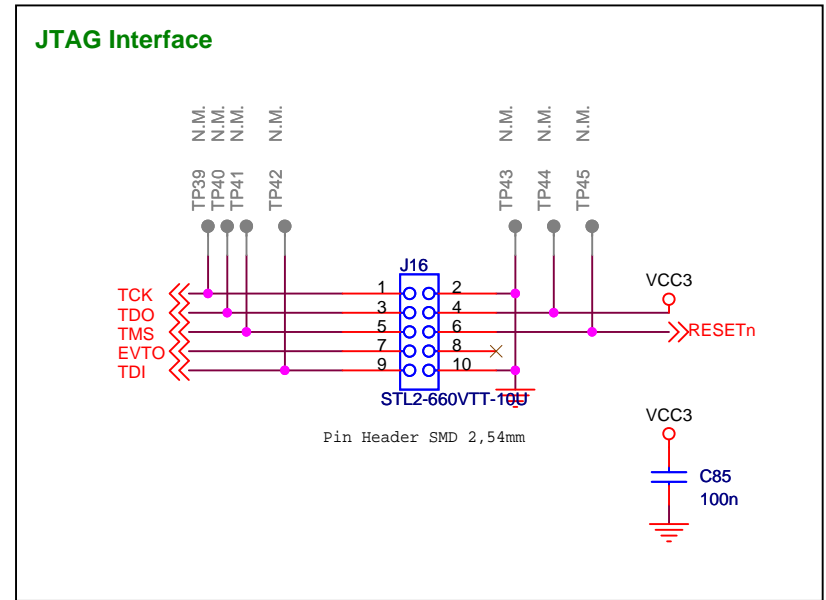
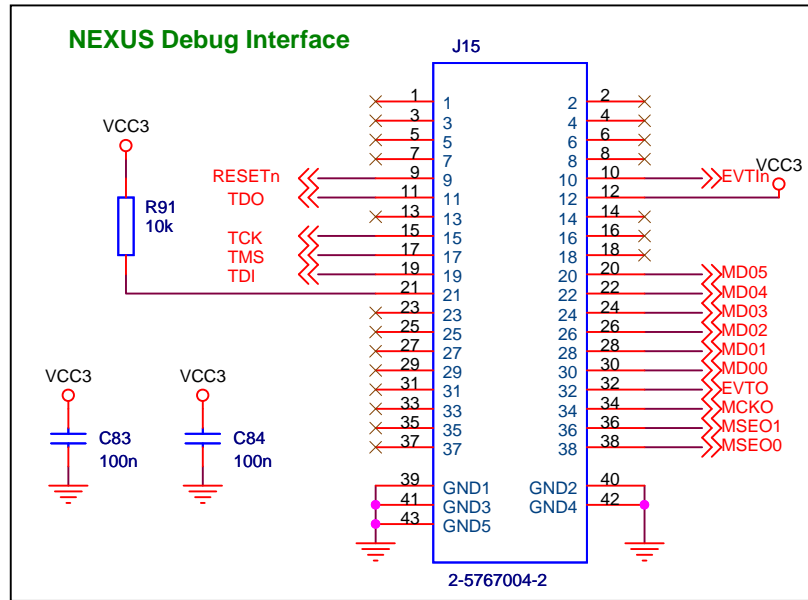
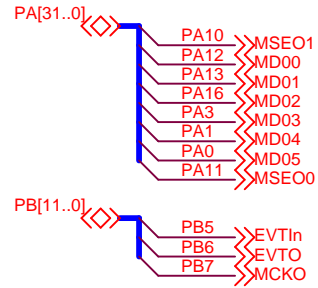

Production

ATMEL Nantes SA
 La Chantrerie BP 70602
 44306 Nantes Cedex 3
 FRANCE



Title		EVK1104	
Size	Document Number	Rev	
A4	Debug	3	
Date:	Friday, October 31, 2008	Sheet	9 of 12

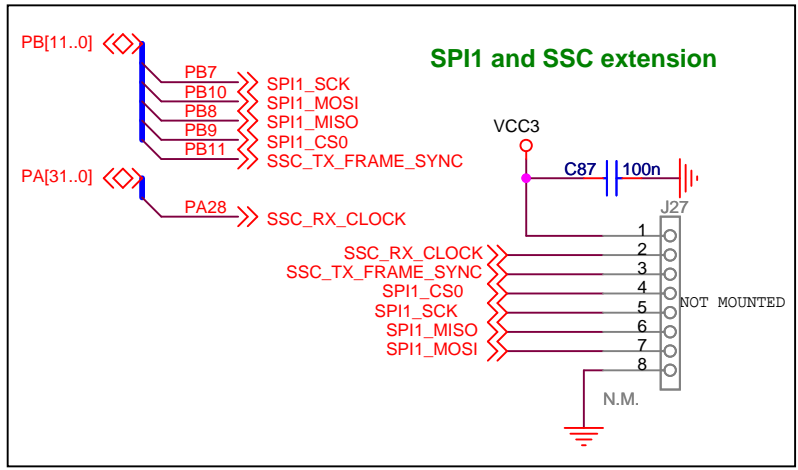
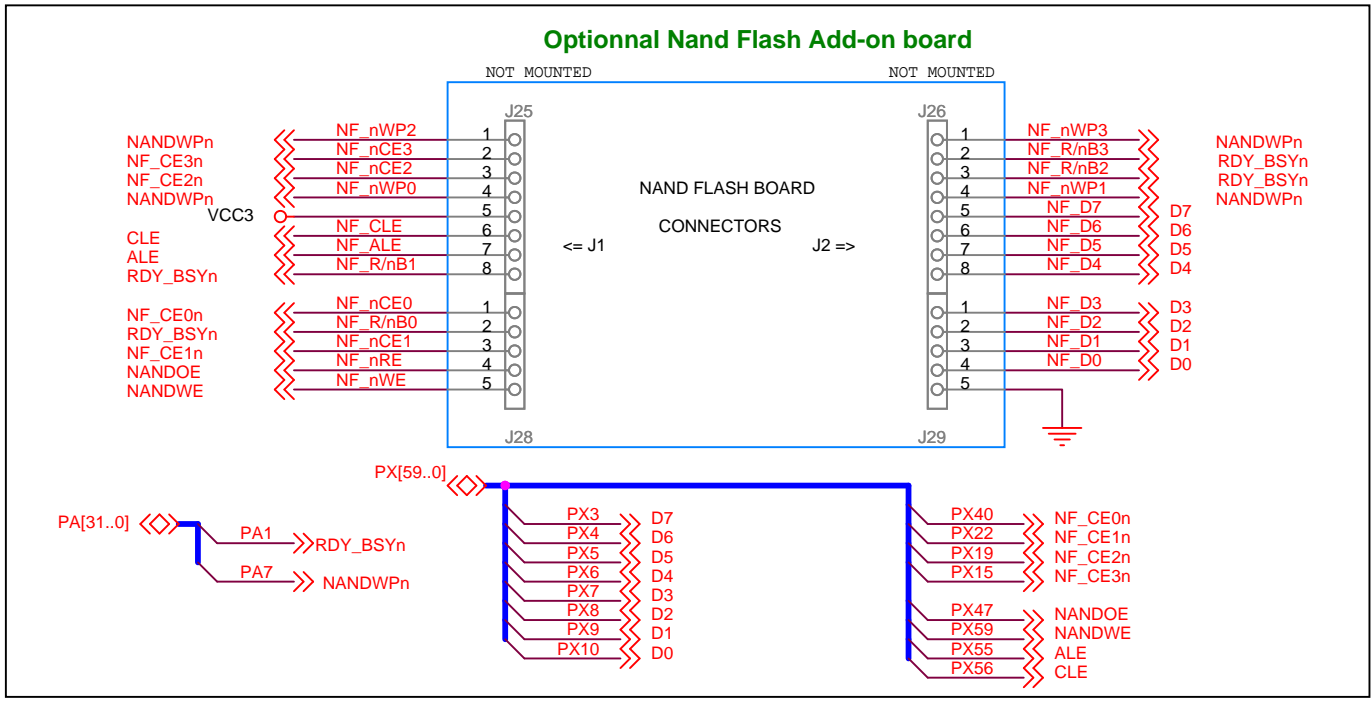
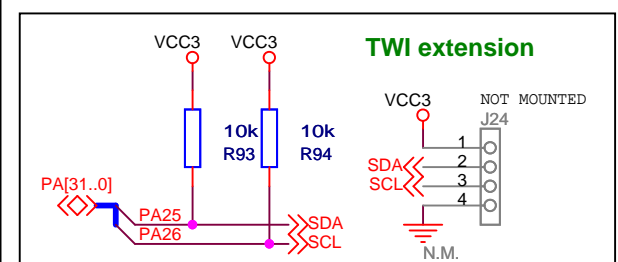
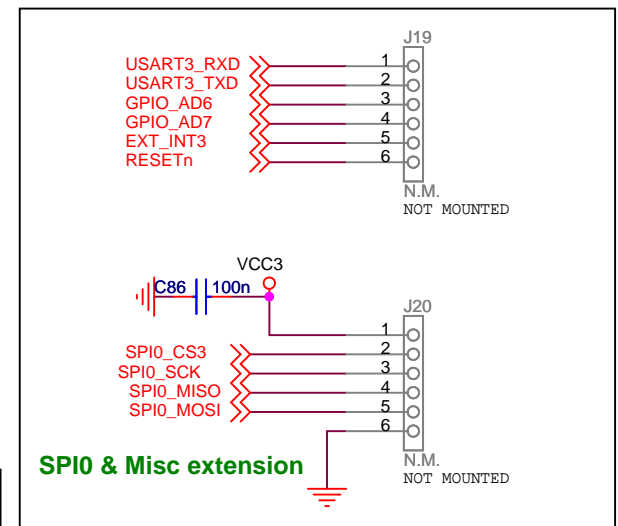
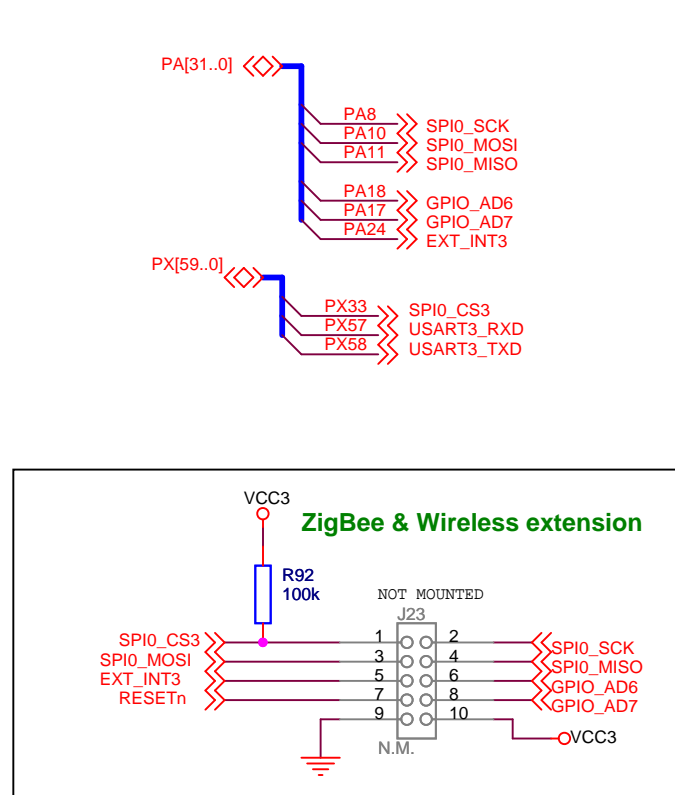
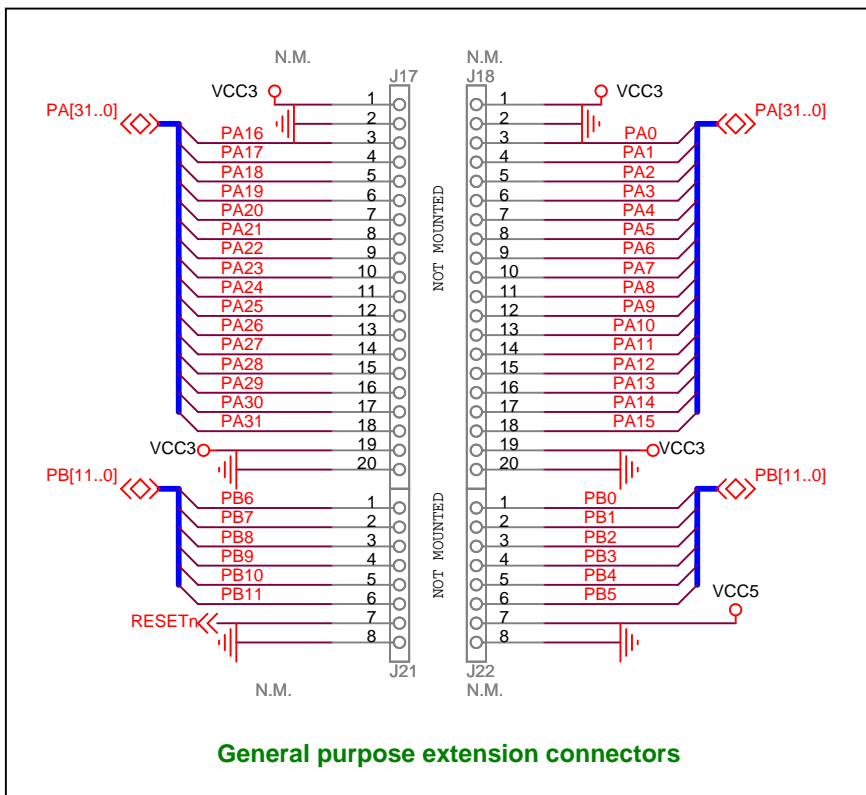

Production

ATMEL Nantes SA
La Chantrerie BP 70602
44306 Nantes Cedex 3
FRANCE

Title		EVK1104	
Size	Document Number	Extensions	
A4			3
Date:	Friday, October 31, 2008	Sheet	10 of 12

USB Virtual Com Port Connector

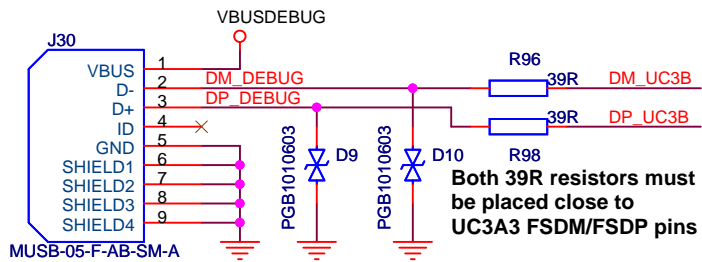

JTAG Connection UC3B (Master) => UC3A3 (Slave)

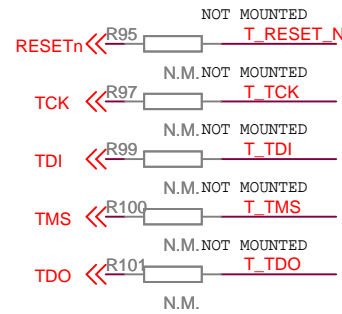

UC3B for UC3A3 USART & JTAG communication through USB

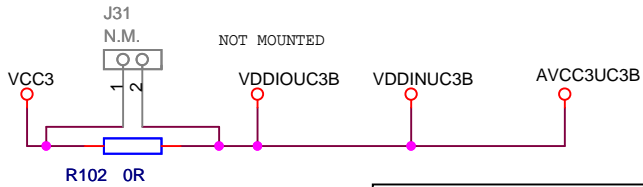
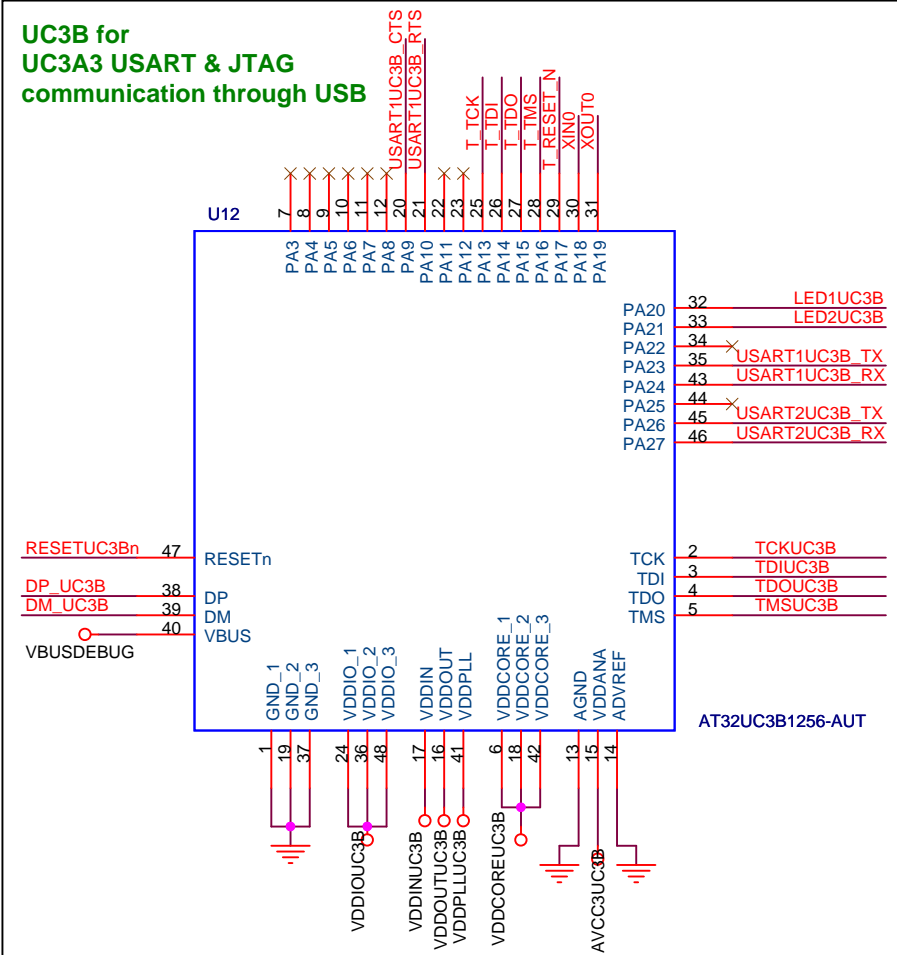

General Purpose Leds Controlled by UC3B

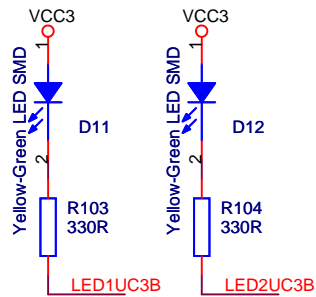

UC3B Main Clock

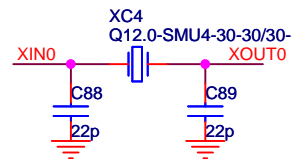

1.8V external loop

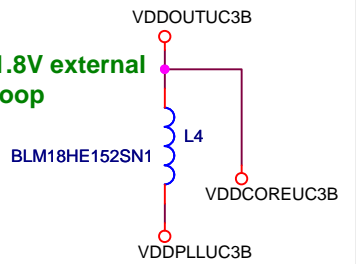

Decoupling capacitors

1.8V PLL power supply

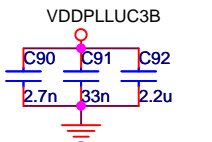

3.3V I/O power supply

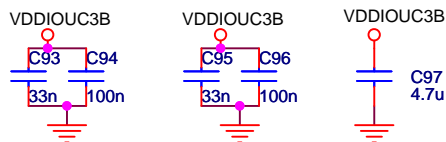

1.8V regulator output

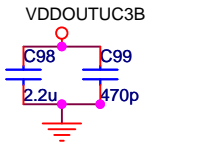

3.3V regulator power supply

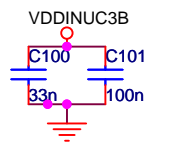

1.8V Core power supply

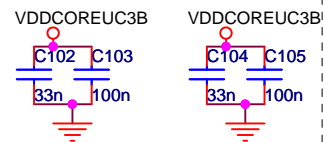

UC3B <=> UC3A3 USART connection

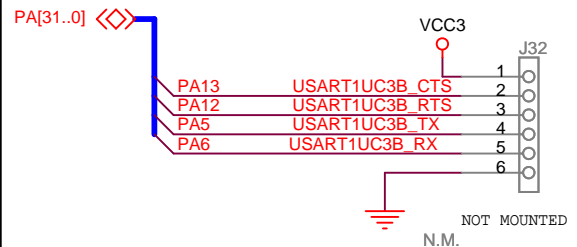

UC3B USART spare

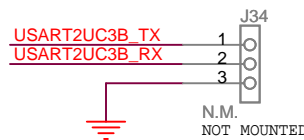

JTAG Interface of UC3B

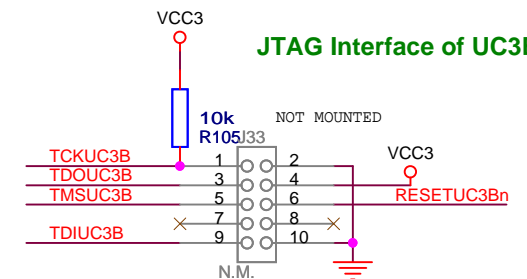

Production

ATMEL Nantes SA
La Chantrerie BP 70602
44306 Nantes Cedex 3
FRANCE



Title EVK1104

Size A4 Document Number

USB Virtual Com Port

Rev 3

Date: Friday, October 31, 2008

Sheet 11 of 12

LOG FILE

REV A/ **Created (SJ, AR)**

REV B/ **Fixed D11 and D12 symbols (SJ 03/09/08)**

REV 3/ **Fixed R70 to 200K instead of 4.3K and change LCD MPN (TL 31/10/08)**

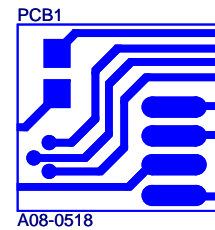
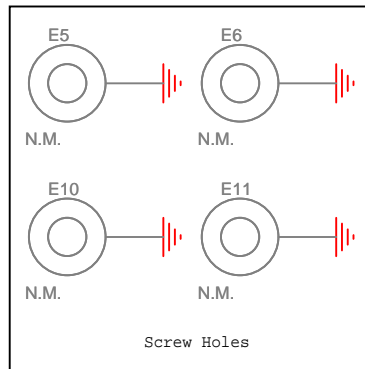
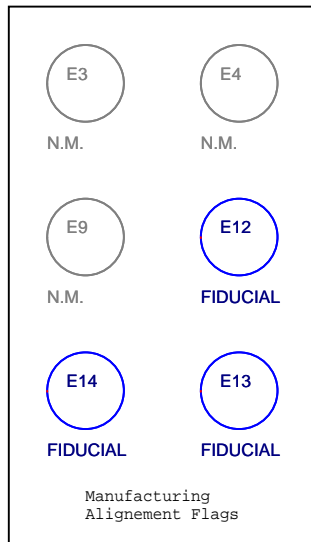
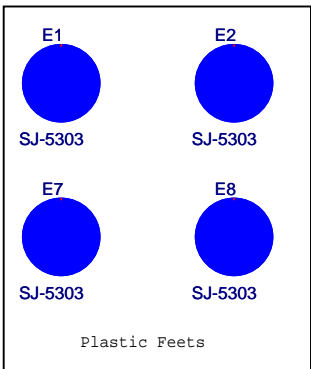

Production

ATMEL Nantes SA
La Chantrerie BP 70602
44306 Nantes Cedex 3
FRANCE



Title		EVK1104	
Size	Document Number	Rev	
A4	Log	3	
Date:	Friday, October 31, 2008	Sheet	12 of 12