

# Model 355 Installation Instructions

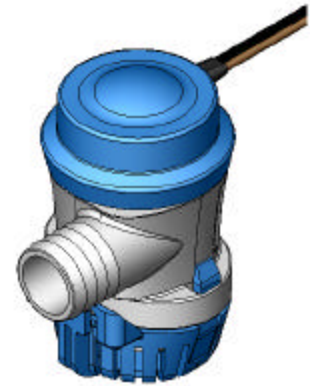

## BILGE PUMP FEATURES

- Quick-disconnect base plate for easy installation.
- Nylon Impeller.
- Submersible.
- 3 ft. tinned power leads to insure operation in the wettest conditions.
- Water cooled motor to insure long life.
- Easy transom mount base plate.

## INSTALLATION

**LOCATION:** Locate pump at deepest position in the bilge. Keep away from high heat source; engine, etc.

**MOUNTING:** Mount quick-disconnect bracket to hull or pad with stainless steel screws. Mount switch if equipped. ***Do not drive screws through hull!*** **TUBING:** Route smooth I.D. discharge tubing to a thru-hull fitting well above the water line. **AVOID AIRLOCK & MAXIMIZE PERFORMANCE:** Avoid any sagging or loops in the tubing. Tubing must go up from pump to thru-hull.

## ELECTRICAL

Use 16GA wire for all circuits. If installation is over 20 feet, use 14GA wire. Brown pump wire must be hooked to positive power for maximum flow. Wire is designed to prevent corrosion. **PANEL SWITCH:** Attach all wires to UL Marine approved duty switch with auto-off-manual, rated at or above 10 amps. **FUSE:** Install a fuse per pump label specifications. **CONNECTIONS:** Wire connections should be made above highest possible water level. Seal wire connections to prevent corrosion and electrolysis.

## OPERATION

**DO NOT RUN PUMP DRY. ALWAYS TEST PUMP AND SWITCH BEFORE LEAVING DOCK.**

**MANUAL MODE:** When brown wire from switch is not hooked up, the pump float switch is bypassed. To turn pump on, turn switch on. If pump does not turn on, turn switch off, check power, fuses, connections, wires. Retry. If pump does not turn on, check pump motor. When the water level is above the float switch, the pump will automatically start. If the float becomes jammed with debris, the pump will **NOT STOP** running. Turn the pump switch to the **OFF** position. Remove the debris. Reset switch to the automatic or manual **ON** position. Test. **SWITCH TEST:** Turn power ON to pump switch. Use a quarter or flat head.

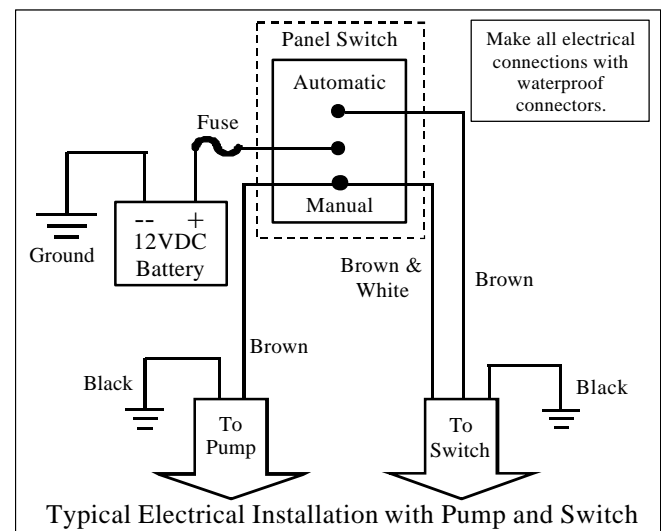
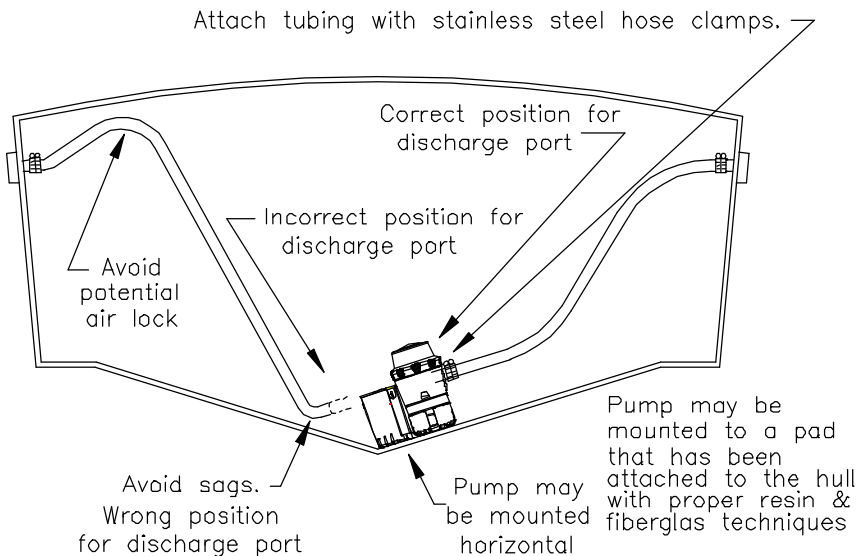

**CLEANING:**

**Impeller:** Snap pump out of base plate by pressing in the tabs. Clean debris and snap back in place. Test unit.

**Switch:** Remove debris or build-up. Reinstall switch and test unit.

**Switch test:** Turn power on to pump switch.

**WIRING:**

Check all wire connections regularly. Repair sign of corrosion.

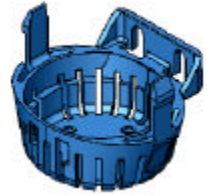

Repair Kit for all models: 94-750-00

FLOW GPM [LPM]				TECHNICAL DATA				
Model #:	0 ft [0 M]	3 ft [1 M]	6 ft [2 M]	Max Head Ft [M]	Max Amps	Fuse	Outlet Port	Dimensions
355-020-10	380 [1438]	340 [1157]	240 [817]	7.5 [2.2]	1.7	2.5	3/4"	4-1/2" X 3"
355-010-10	500 [1892]	430 [1464]	270 [918]	7.5 [2.2]	1.8	2.5	3/4"	4-1/2" X 3"
355-110-10	700 [2649]	600 [2043]	500 [1702]	10 [3]	3.2	5	3/4"	4-1/2" X 3"
355-100-10	1000 [2649]	840 [2861]	650 [2214]	11 [3.3]	3.4	6	1-1/8"	4-1/2" X 3"

**Specifications given at design voltage 13.6 VDC per ABYC recommendations.**

Pump Power leads: 3 ft. [0.9 M] #16 tinned stranded copper wire to minimize corrosion. Positive (+) brown; Ground (-) black

Switch Leads (If equipped with SHURflo Piranha Switch): Automatic (+) brown; Manual (+) brown & white; Ground (-) black

**Temperature limits:** 33°F—140°F [0°C—60°C]. All models rated for continuous duty.

Approvals: Ignition Protected, ISO 8846, ABYC, NMMA Type Accepted, CE

**TROUBLESHOOTING**

Symptoms	Check For
No water pumped Pump not running	Reset pump switch. Blown fuse. Reversed polarity damaged switch board. Wire connections. Impeller or float switch plugged with debris.
Reduced water flow	Impeller/screen plugged with debris. Pinched/clogged discharge tubing. Discharge tubing sagging below pump causing air lock (Tubing MUST go "UP" from pump to through hull fitting). Low voltage to pump; check. Battery/wire connections.
Low flow	Polarity reversed (on pump only); check wiring. Use smooth bore (I.D.) discharge tubing only. Is through hull fitting I.D. smaller than pump discharge port?
Runs continuously	Check boat for leaks; Clean accumulated debris from float mechanism.

**Do not pump oil, diesel fuel, gasoline or other flammable liquids with this pump.**



**WARNING**

This pump does not prevent the discharge of oil or other chemicals into the water. Please take appropriate measures to prevent discharging oil or other chemicals and safeguard the environment. Always disconnect power before servicing pump. Always use fuse size specified in specifications. These bilge pumps are designed to evacuate standing bilge water only. These pumps may not prevent boat sinkage due to storms, rough weather, unsafe boating, improper installation procedures or hull damage.



**LIMITED WARRANTY**

SHURflo warrants its SHURflo™ series bilge pumps to be free of defects in material and workmanship under normal use for a period of three (3) years from the date of manufacture, as indicated on the pump label. Returns are to be shipped prepaid to SHURflo. This warranty is only a representation of the complete marine products limited warranty, outlined by Service Bulletin #1050. Call or write for a copy.



- ES** Favor de referirse a [www.shurflo.com](http://www.shurflo.com) para instrucciones de la instalación del producto y su operación, disponible en varios idiomas.
- DE** Mehrsprachige Hinweise zu Installation und Betrieb des Produktes finden Sie unter [www.shurflo.com](http://www.shurflo.com)
- IT** Fare riferimento al sito [www.shurflo.com](http://www.shurflo.com) per manuali multilingue di installazione ed utilizzo prodotti.
- FR** Veuillez vous référer au site [www.shurflo.com](http://www.shurflo.com) pour l'installation produit multilingue ainsi que pour le mode d'emploi.
- UK** Please refer to [www.shurflo.com](http://www.shurflo.com) for multi-lingual product installation and operating instructions'

SHURflo reserves the right to update specifications, prices, or make substitutions.

**SHURflo, LLC Headquarters**

5900 Katella Avenue  
Cypress, California 90630  
Phone (562) 795-5200 • Toll Free (800) 854-3218  
Fax (562) 795-7564

**SHURflo, LLC East**

52748 Park Six Court  
Elkhart, Indiana 46514-5427  
Phone (562) 795-5200 • Toll Free (800) 854-3218  
Fax (574) 264-2169

**SHURflo Europe, Middle East, Africa**

**Pentair Water Belgium bvba,**  
Industriepark Wolfstee, Toekomstlaan 30  
B-2200 Herentals, Belgium  
Phone +32-14-283500 • Fax +32-14-283505