

TFT-Display Datenblatt

Modell PO023OX1

Kurzdaten

Hersteller	PrimeView
Diagonale	2,3" / 5,8cm
Format	round
Auflösung	240x240
Backlight	LED/1000cd/m ²
Temperatur	-30...+80°C (Betrieb)

Version : 1.0



Inselkammerstr. 10
82008 Unterhaching
Tel: +49 89 614 503 40
www.hy-line.de/computer

TECHNICAL SPECIFICATION
MODEL NO. : PO023OX1

The content of this information is subject to be changed without notice.
Please contact PVI or its agent for further information

Customer' s Confirmation

Customer _____

Date _____

By _____

PVI' s Confirmation



Confirmed By _____



Prepared By _____

Revision History

Rev.	Issued Date	Engineer	Revised	Contents
1.0	Apr. 01, 2008	吳昌霖	New	

TECHNICAL SPECIFICATION

CONTENTS

<i>NO.</i>	<i>ITEM</i>	<i>PAGE</i>
-	Cover	1
-	Revision History	2
-	Contents	3
1	Application	4
2	Features	4
3	Mechanical Specifications	4
4	Mechanical Drawing of TFT-LCD module	5
5	Input / Output Terminals	6
6	Absolute Maximum Ratings	7
7	Electrical Characteristics	8
8	Pixel Arrangement	9
9	Block Diagram	9
10	Timing specification	10
11	Interface specification	12
12	Optical Characteristics	14
13	Handling Caution	17
14	Reliability Test	19
15	Packing	20

1. Application :

The PO0230X1 applies to a color TFT LCD module which has octagonal outline. PO0230X1 module applies to OA product, GPS, which require high quality flat panel display. If you must use in high reliability environment can't over reliability test condition.

2. Features :

- . Pixel in stripe configuration
- . Slim and compact
- . Wide viewing angle
- . High Brightness
- . Octagonal LCD
- . Driver IC : HX8325

3. Mechanical Specifications :

Parameter	Specifications	Unit
Screen Size	2.3" TFT LCD	inch
Display Format	240×(R, G, B)×240	dot
Display Colors	65,536	
Active Area	D = 57.96 (Circular)	mm
Pixel Pitch	0.2415×0.2415	mm
Pixel Configuration	Stripe	
Outline Dimension	75.60(W)×75.70(H)×7.64(D)	mm
Weight	46±5	g
Surface treatment	Anti-glare and wide-view film	
Back Light	2-LED,150mA	
Display mode	Normally white	
Gray scale inversion direction	6 [Refer to Note 12-1]	o' clock

4. Mechanical Drawing of TFT-LCD Module :

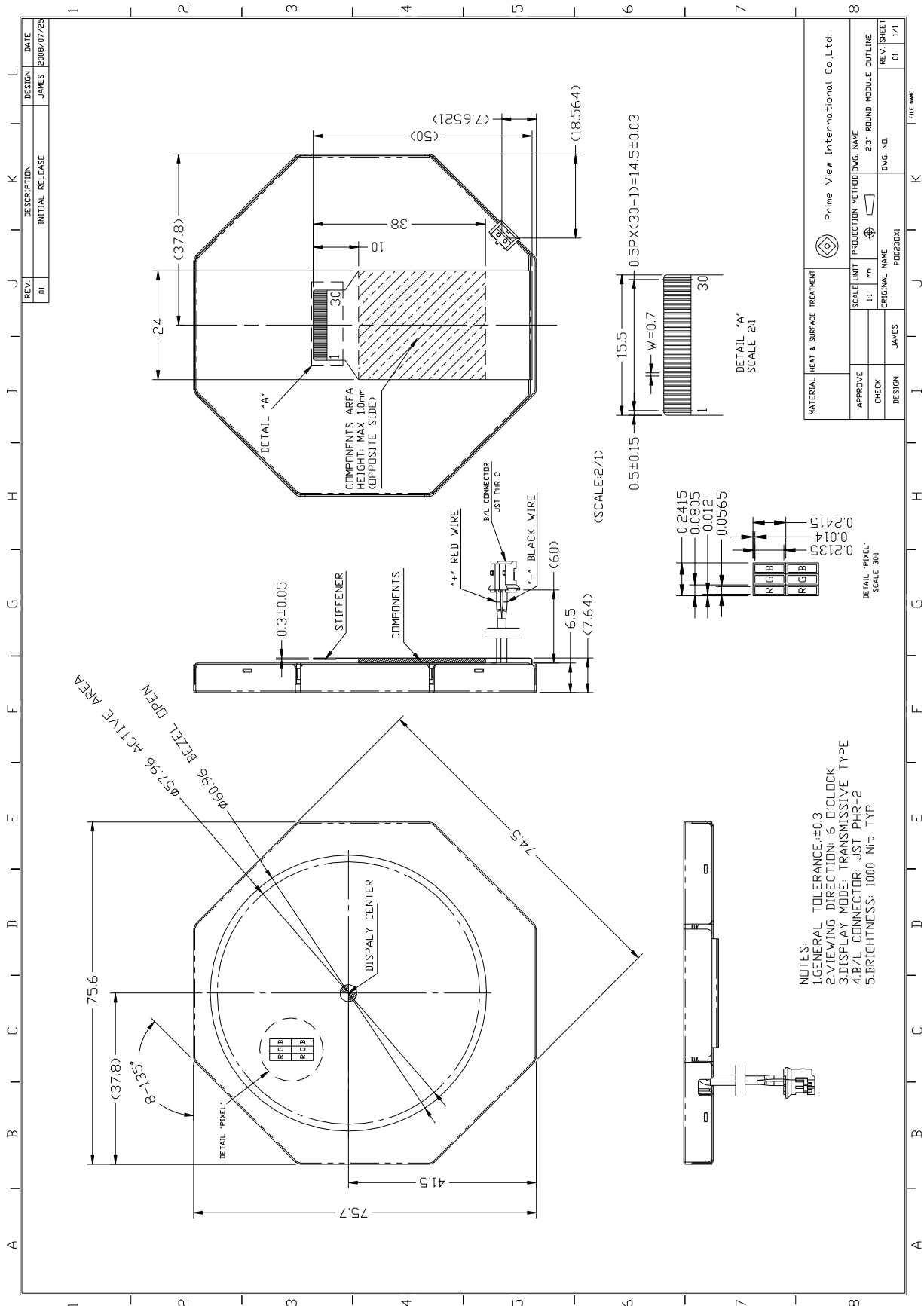

5. Input / Output Terminals :

LCD Module Connector
 FPC Down Connect, 30 Pins

Pin No.	Signal	Pin Function	Remark
1	VSS	Ground	
2	VSS	Ground	
3	NRESET	Reset Input Pin	
4	Dummy	N.C.	
5	D15	Parallel Data Bus (R4)	
6	D14	Parallel Data Bus (R3)	
7	D13	Parallel Data Bus (R2)	
8	D12	Parallel Data Bus (R1)	
9	D11	Parallel Data Bus (R0)	
10	D10	Parallel Data Bus (G5)	
11	D9	Parallel Data Bus (G4)	
12	D8	Parallel Data Bus (G3)	
13	D7	Parallel Data Bus (G2)	
14	D6	Parallel Data Bus (G1)	
15	D5	Parallel Data Bus (G0)	
16	D4	Parallel Data Bus (B4)	
17	D3	Parallel Data Bus (B3)	
18	D2	Parallel Data Bus (B2)	
19	D1	Parallel Data Bus (B1)	
20	D0	Parallel Data Bus (B0)	
21	Dummy	N.C.	
22	NRD_E	Read Signal Pin	
23	NWR_RNW	Write Signal Pin	
24	DNC_SCL	Register Index or Register Command Select	
25	NCS	Chip Select Pin	
26	Dummy	N.C.	
27	VCI	Power Supply (Typ. 3.0V)	
28	VCI	Power Supply (Typ. 3.0V)	
29	VSS	Ground	
30	VSS	Ground	

6. Absolute Maximum Ratings :

The followings are maximum values, which if exceeded, may cause faulty operation or damage to the unit.

VSS=GND=0V , Ta = 25°C

Item	Symbol	Value	Unit	Remark
Power supply voltage (1)	VCC, IOVCC	-0.3 to +4.6	V	Note 6-1 Note 6-2
Power supply voltage (2)	VCI	-0.3 to +4.6	V	Note 6-1 Note 6-3
Power supply voltage (3)	VLCD-VSSA	-0.3 to +6.5	V	Note 6-1 Note 6-4
Power supply voltage (4)	VSSA-VCL	-0.3 to +4.6	V	Note 6-1 Note 6-5
Drive Supply Voltage	VGH-VGL	32	V	Note 6-1 Note 6-6
Input Voltage Range	V _{IN}	-0.3 to IOVCC+0.3	V	Note 6-1
Output Voltage Range	V _O	-0.3 to IOVCC+0.3	V	Note 6-1

Note 6-1 : VCC,VSSD must be maintained, VSSD=VSSA=0V

Note 6-2 : Make sure $VCC \geq VSSD$, $IOVCC \geq VSSD$

Note 6-3 : Make sure $VCI \geq VSSA$

Note 6-4 : Make sure $VLCD \geq VSSA$

Note 6-5 : Make sure $VSSA \geq VCL$

Note 6-6 : Make sure $VGH \geq VSSA$ and $VSSA \geq VGL$

7. Electrical Characteristics :

7-1 Operation condition :

VSS=GND=0V , Ta = 25°C

Item	Symbol	Value	Unit	Remark
Power supply voltage (1)	VCI-VSS	3±0.2	V	Note 7-1
Power supply voltage (2)	VLCD-VSS	4.63	V	
Power supply voltage (3)	VSS-VCL	2.67	V	
Power supply voltage (4)	VLCD-VCL	7.3	V	
Power supply voltage (5)	VGH-VSS	13.7	V	
Power supply voltage (6)	VSS-VGL	10.21	V	
TFT Common Electrode Voltage	VCOMH	3.6	V	Note 7-2
	VCOML	-0.71	V	
Coupling voltage	Δ Vp	0.82	V	
Black of Video Low Voltage	VLB	0.24	V	Note 7-3
Black of Video High Voltage	VHB	4.24	V	
White of Video Low Voltage	VLW	0.2	V	
White of Video High Voltage	VHW	4.18	V	

Note 7-1 : The VCI 3±0.2V is base on item 11-2 setting, if out of range, will be have some display abnormal

Note 7-2 : VCOM must be adjusted optimize display quality, crosstalk, contrast ration and etc.

Note 7-3 :

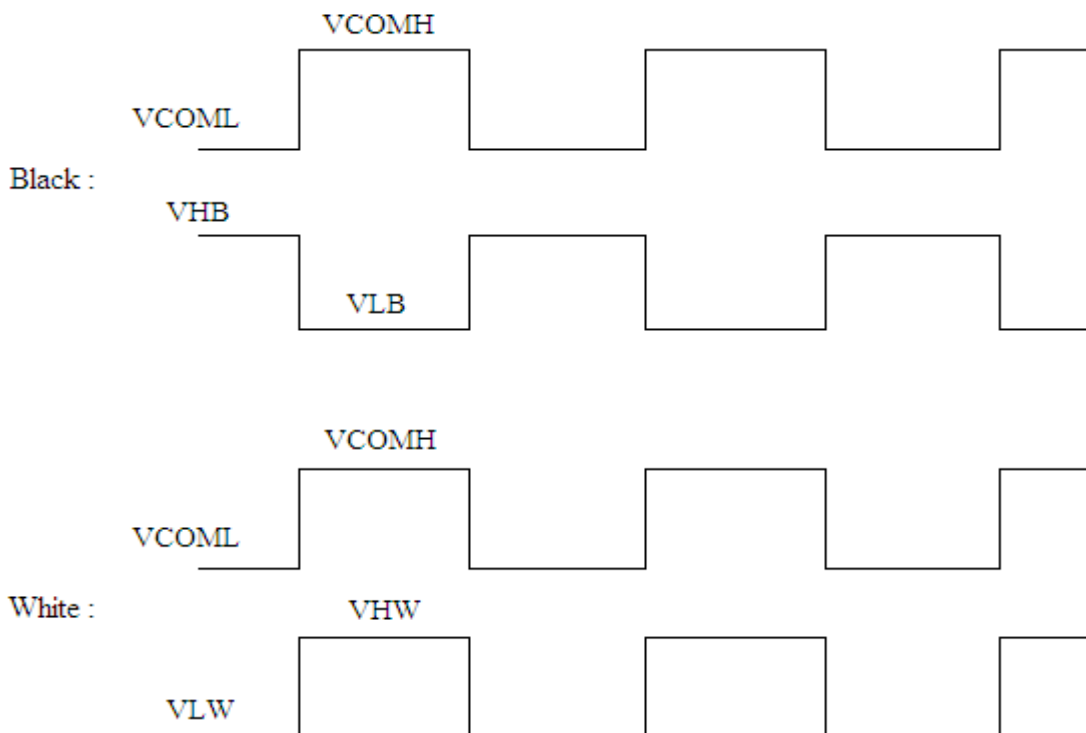

7-2 Power consumption :

Parameter	Symbol	Min	TYP	MAX	Unit	Remark
Supply voltage of LED backlight	V_{LED}	-	-	(7.6)	V	Note 7-4
Supply current of LED backlight	I_{LED}	-	150	-	mA	Note 7-5
Backlight Power Consumption	P_{LED}	-	-	1140	mW	Note 7-6

Note 7-4 : The $I_{LED}=150$ mA (Constant current)

Note 7-5: LED B/L applied information

Note 7-6: $P_{LED} = V_{LED} * I_{LED}$.



Parameter	Symbol	Conditions	TYP.	MAX.	Unit	Remark
Supply current for source driver and gate driver	I_{CI}	$V_{CI} = 3.0V$	11.7	17.6	mA	
Backlight Power Consumption	P_{LED}	-	-	1140	mW	
Total power consumption	-	-	-	1192.8	mW	

8. Pixel Arrangement :

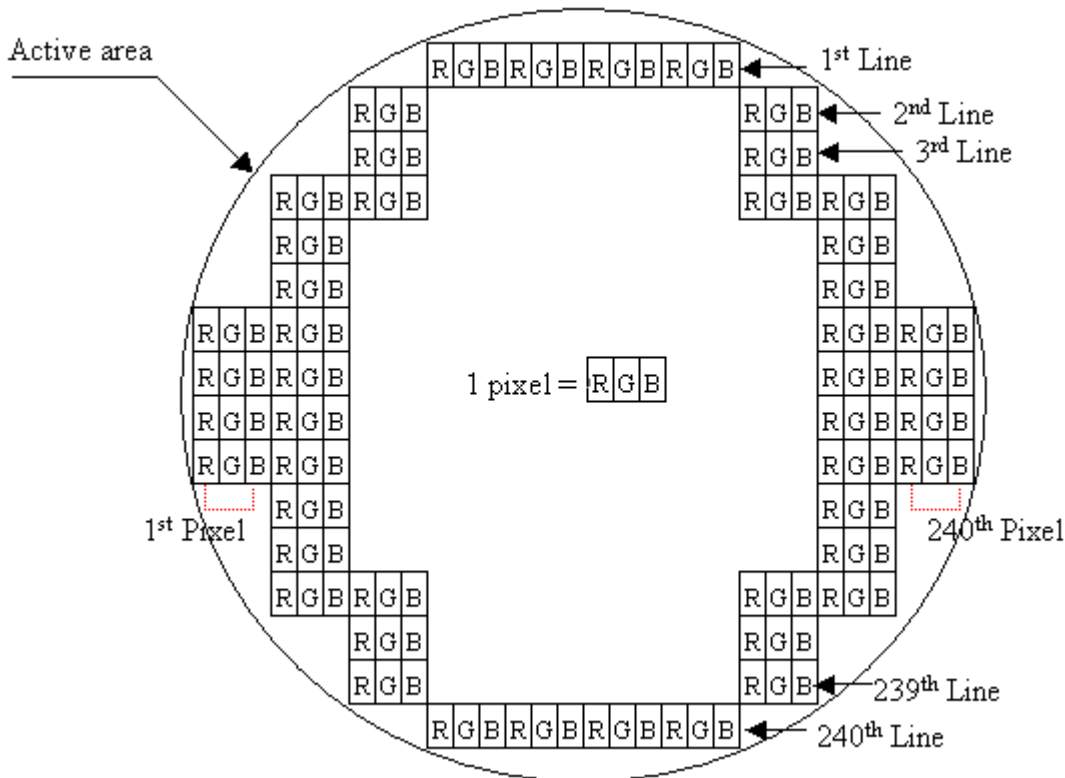

9. Block Diagram :

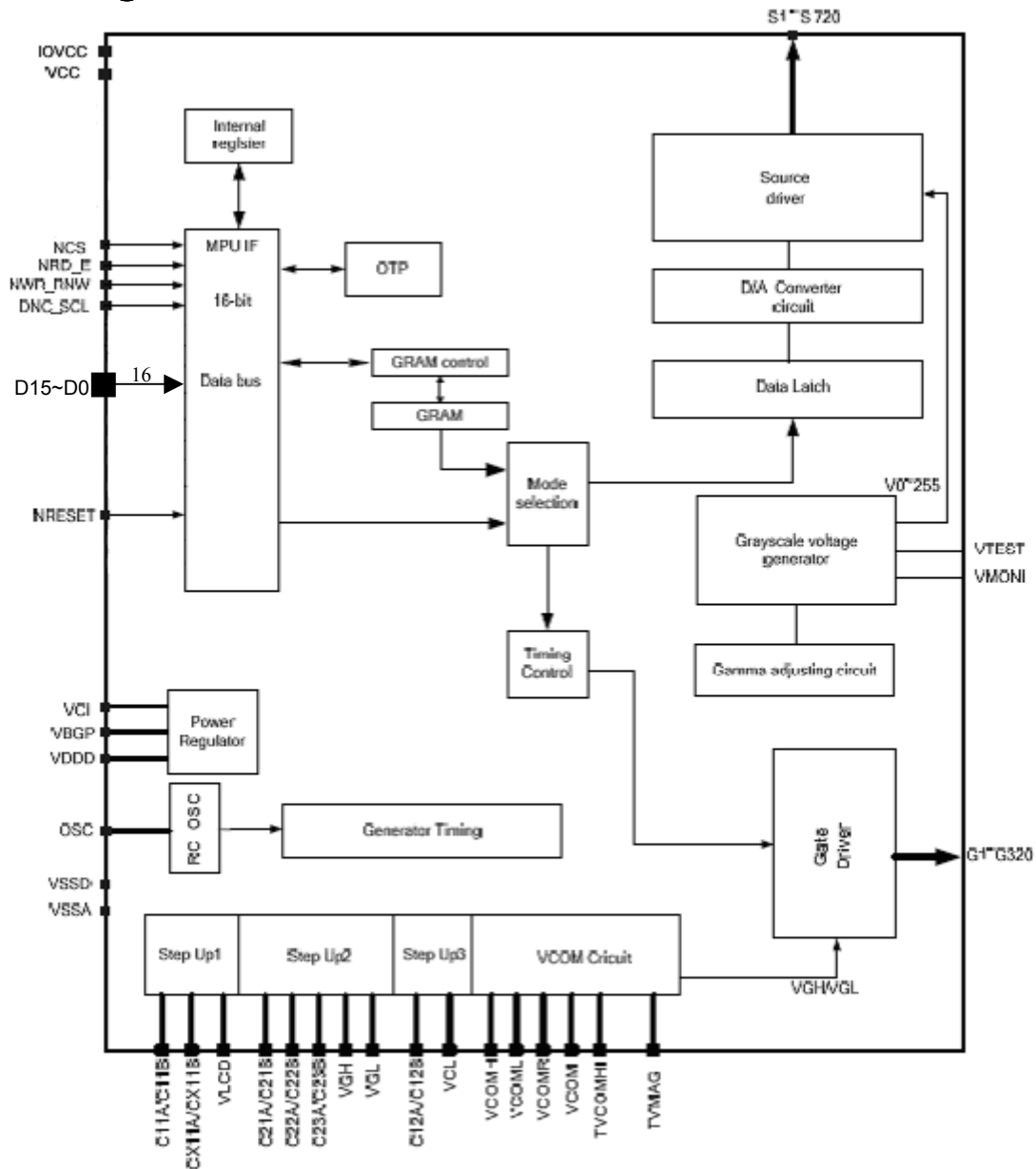

10. Timing specification :

10-1. 80-system Bus Operation :

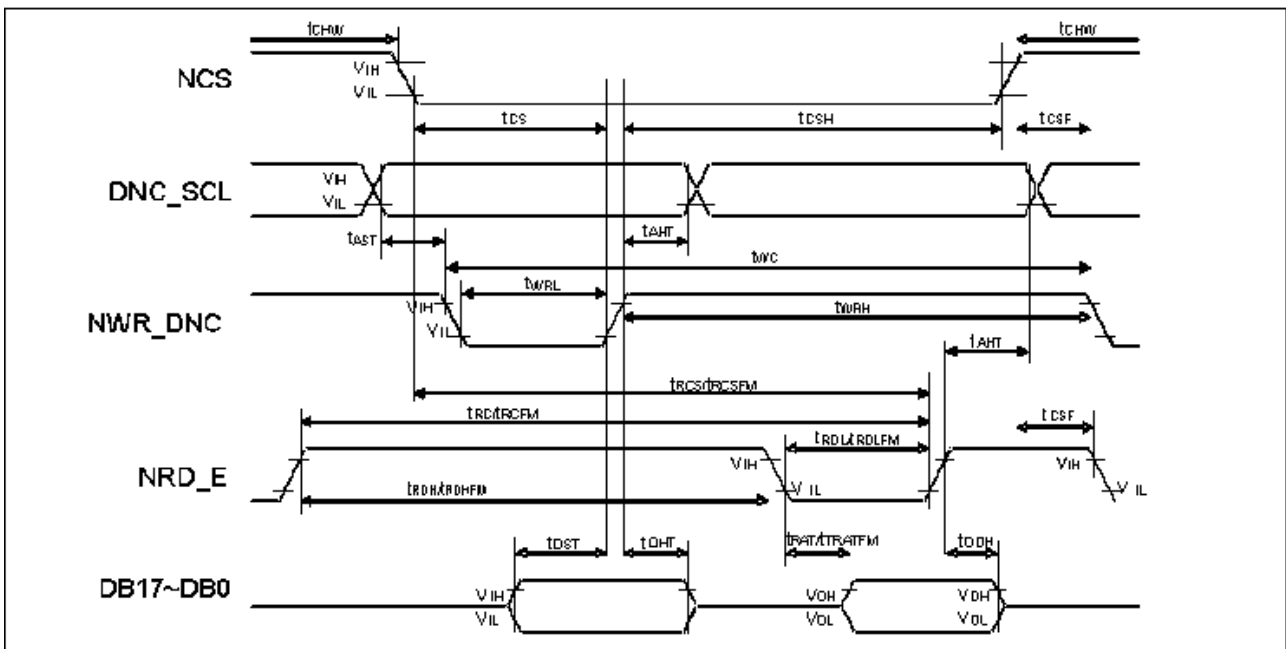

10-2. AC Characteristics :

10-2.1 80-system Bus Interface Timing Characteristics :

Table.10-2.1 80-System Normal Write Mode (HWM =0)/ (VCI=3V)

DNC_SCL	tAST	Address setup time	10	-	ns
	tAHT	Address hold time(Write/Read)	10	-	
NCS	tCHW	Chip select "H" pulse width	0	-	ns
	tCS	Chip select setup time(Write)	35	-	
	tRCSFM	Chip select setup time	355	-	
	tCSF	Chip select wait time(Write/Read)	10	-	
	tCSH	Chip select hold time	10	-	
NWR_RNW	tWC	Write cycle	100	-	ns
	tWRH	Control pulse "H" duration	35	-	
	tWRL	Control pulse "L" duration	35	-	
NRD_E	tRCFM	Read cycle	450	-	ns
	tRDHFM	Control pulse "H" duration	90	-	
	tRDLFM	Control pulse "L" duration	355	-	
D17 to D0	tDST	Data setup time	15	-	ns
	tDHT	Data hold time	10	-	
	tRATFM	Read access time	-	340	
	tODH	Output disable time	20	80	

11. Interface specification :

11-1. 16-bit bus interface :

The 80-system 16-bit bus parallel data transfer can be used by setting M3-0 pins to “ 0010” .

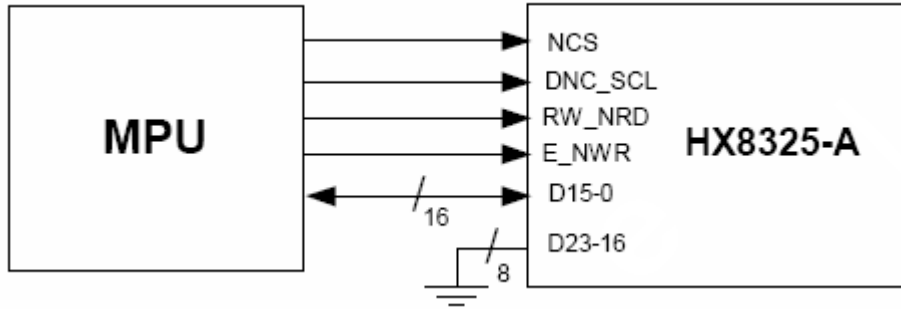

Figure.11-1-2 A Example of 80-System 16-bit Interface

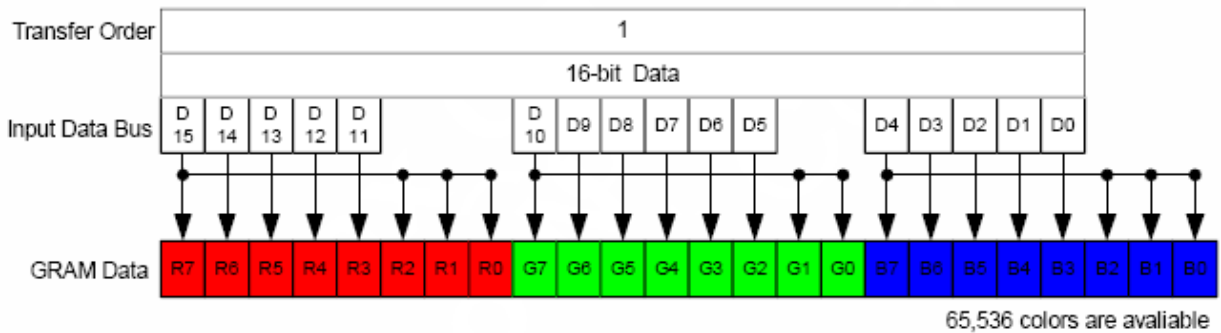
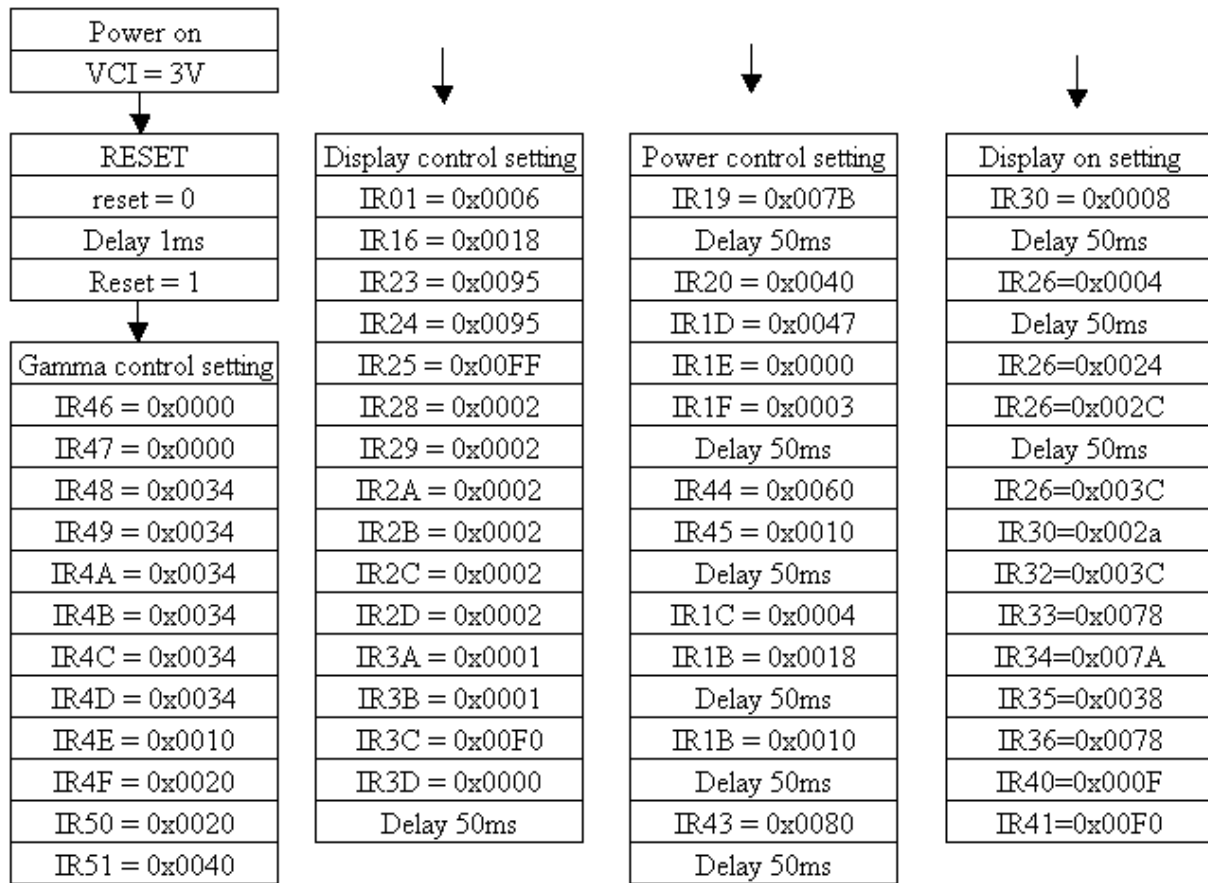

Figure.11-1-2 B Data Format of 16-bit bus System Interface

11-2. Display on Flow :



12. Optical Characteristics :

Ta=25°C

Parameter		Symbol	Condition	MIN.	TYP.	MAX.	Unit	Remarks
Viewing Angle	Horizontal	θ_{11} 、 θ_{12}	CR \geq 10	70	75	-	deg	Note 12-1
	Vertical	θ_{22}		45	50	-	deg	
		θ_{21}		65	70	-	deg	
Contrast Ratio		CR	At optimized view angle	200	400	-	-	Note 12-2
Brightness		L	$\theta = 0^\circ$	800	1000		cd/m ²	Note 12-4
Uniformity		U%	$\theta = 0^\circ$	70	75	-	%	Note 12-5
Response time	Rise	Tr	$\theta = 0^\circ$	-	15	20	ms	Note 12-3
	Fall	Tf		-	20	30	ms	
White Chromaticity		x	$\theta = 0^\circ$	0.29	0.33	0.37	-	
		y		0.31	0.35	0.39	-	
LED Life Time		-	+ 25°C	20000	30000	-	hrs	Note 12-6

Note 12-1: The definitions of viewing angles are as follow

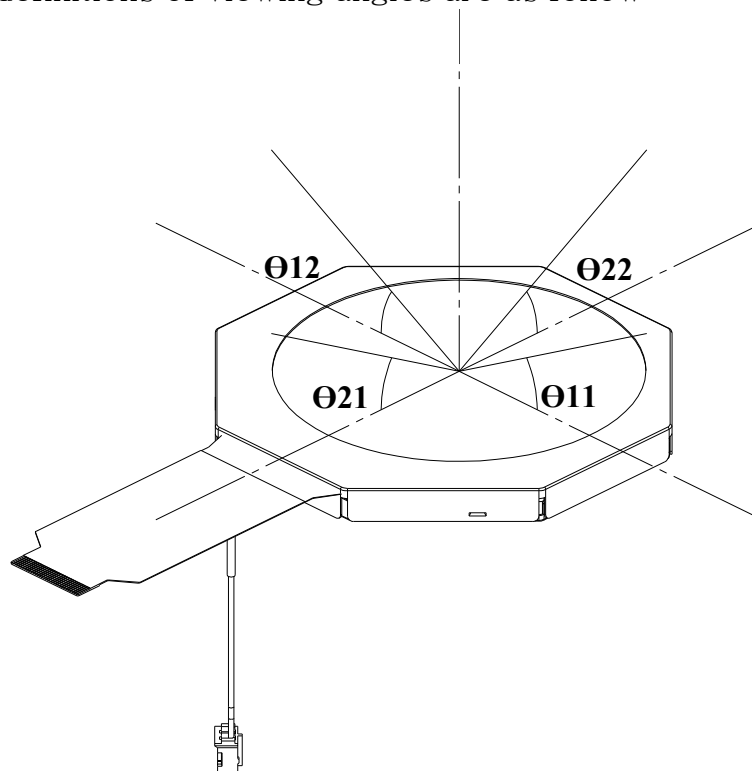

Note 12-2: The definition of contrast ratio : $CR = \frac{\text{Luminance at White Pattern}}{\text{Luminance at Black Pattern}}$

Note 12-3: Definition of Response Time T_r and T_f :

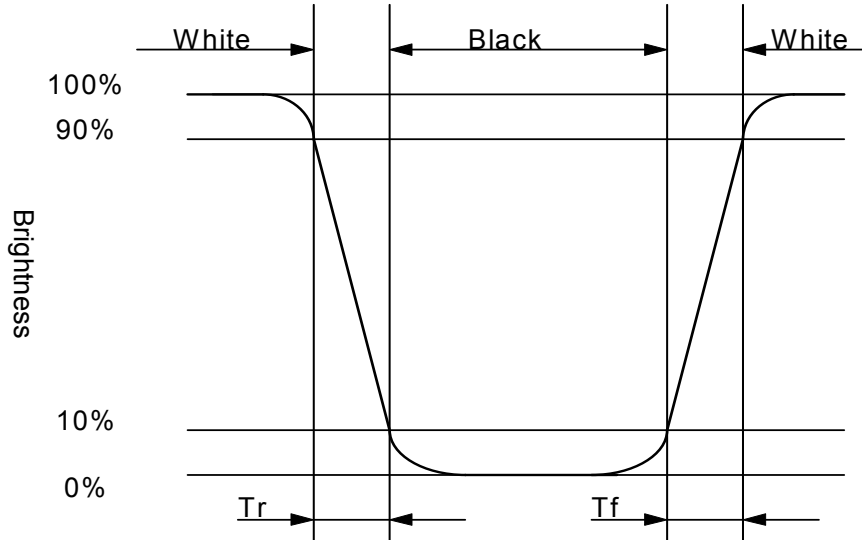

Note 12-4: All optical measurements shall be performed after backlight being turned-on for 30 mins. The optical characteristics shall be measured in dark room (ambient illumination on panel surface less than 1 Lux). The measuring configuration shows as following figure.

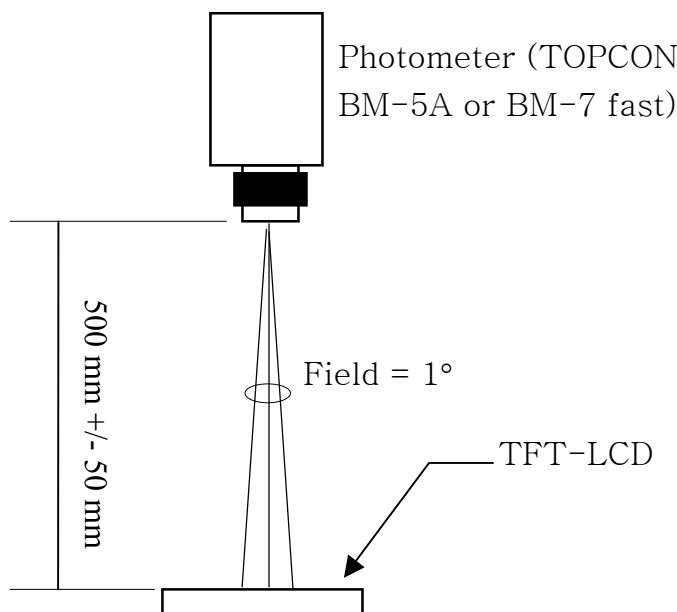

Optical characteristics measuring configuration

Note 12-5 : The uniformity of LCD is defined as

$$U = \frac{\text{The Minimum Brightness of the 9 testing Points}}{\text{The Maximum Brightness of the 9 testing Points}}$$

Luminance meter : BM-5A or BM-7 fast (TOPCON)

Measurement distance : 500 mm +/- 50 mm

Ambient illumination : < 1 Lux

Measuring direction : Perpendicular to the surface of module

The test pattern is white

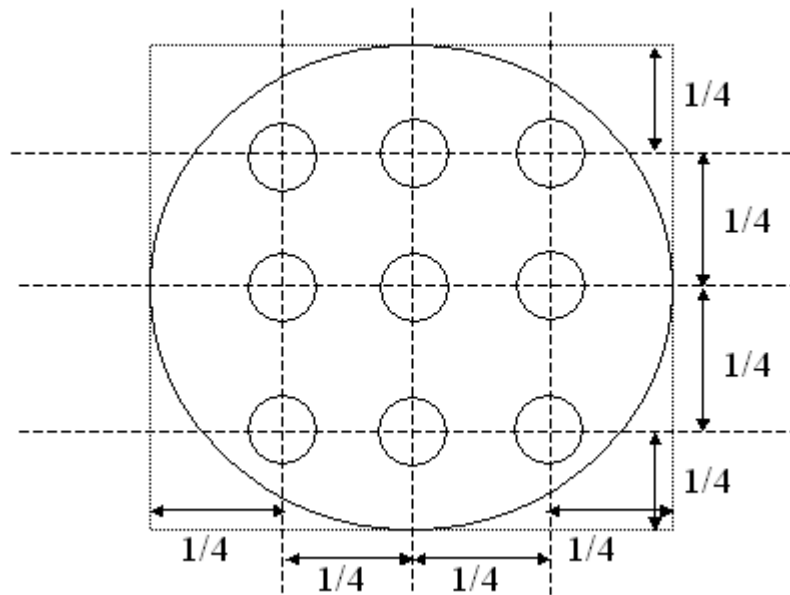

Note 12-6: The “ LED Life time “ is defined as the module brightness decrease to 50% original Brightness that the ambient temperature is 25°C and $I_{LED} = 150\text{mA}$.

13. Handling Cautions :

13-1) Mounting of module :

- a) Please power off the module when you connect the input/output connector.
- b) Polarizer which is made of soft material and susceptible to flaw must be handled carefully.
- c) Protective film (Laminator) is applied on surface to protect it against scratches and dirt.
- d) **Please following the tear off direction as figure 13-1 to remove the protective film as slowly as possible, so that electrostatic charge can be minimized.**

13-2) Precautions in mounting :

- a) When metal part of the TFT-LCD module (shielding lid and rear case) is soiled, wipe it with soft dry cloth.
- b) Wipe off water drops or finger grease immediately. Long contact with water may cause discoloration or spots.
- c) TFT-LCD module uses glass which breaks or cracks easily if dropped or bumped on hard surface. Please handle with care.
- d) Since CMOS LSI is used in the module. So take care of static electricity and earth yourself when handling.

13-3) Adjusting module

- a) Adjusting volumes on the rear face of the module have been set optimally before shipment.
- b) Therefore, do not change any adjusted values. If adjusted values are changed, the specifications described may not be satisfied.

13-4) Others :

- a) Do not expose the module to direct sunlight or intensive ultraviolet rays for many hours.
- b) Store the module at a room temperature place.
As open the packing, must assembly within 3 month
- c) The voltage of beginning electric discharge may over the normal voltage because of leakage current from approach conductor by to draw lump read lead line around.
- d) If LCD panel breaks, it is possibly that the liquid crystal escapes from the panel. Avoid putting it into eyes or mouth. When liquid crystal sticks on hands, clothes or feet. Wash it out immediately with soap.
- e) Observe all other precautionary requirements in handling general electronic components.

13-4) Polarizer mark :

The polarizer mark is to describe the direction of wide view angle film how to mach up with the rubbing direction.

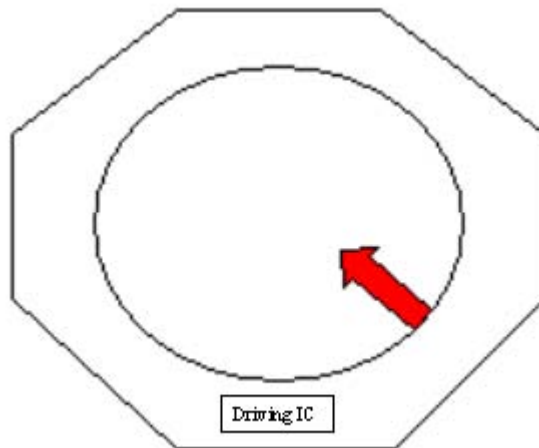

Figure 13-1 the way to peel off protective film

14. Reliability Test :

No	Test Item	Test Condition	Remark
1	High Temperature Storage Test	Ta = 85°C, 240 hrs	
2	Low Temperature Storage Test	Ta = -40°C, 240 hrs	
3	High Temperature Operation Test	Ta = 80°C, 240 hrs	
4	Low Temperature Operation Test	Ta = -30°C, 240 hrs	
5	High Temperature & High Humidity Operation Test	Ta = 60°C, 95%RH, 240 hrs (No Condensation)	
6	Thermal Cycling Test (non-operating)	-30°C → +80°C, 200 Cycles 30 mins 30 mins	
7	Vibration Test (non-operating)	Frequency : 10 ~ 55 Hz Amplitude : 1 mm Sweep time : 11 mins Test Period : 6 Cycles for each direction of X, Y, Z	
8	Shock Test (non-operating)	100G , 6ms Direction : ±X , ±Y , ±Z Cycle : 3 times	
9	Electrostatic Discharge Test (non-operating)	200pF , 0Ω ±200V 1 time / each terminal	

Ta : ambient temperature

[Criteria]

In the standard conditions, there is not display function NG issue occurred. (including : line defect ,no image)All the cosmetic specification is judged before the reliability stress.

15. Packing :

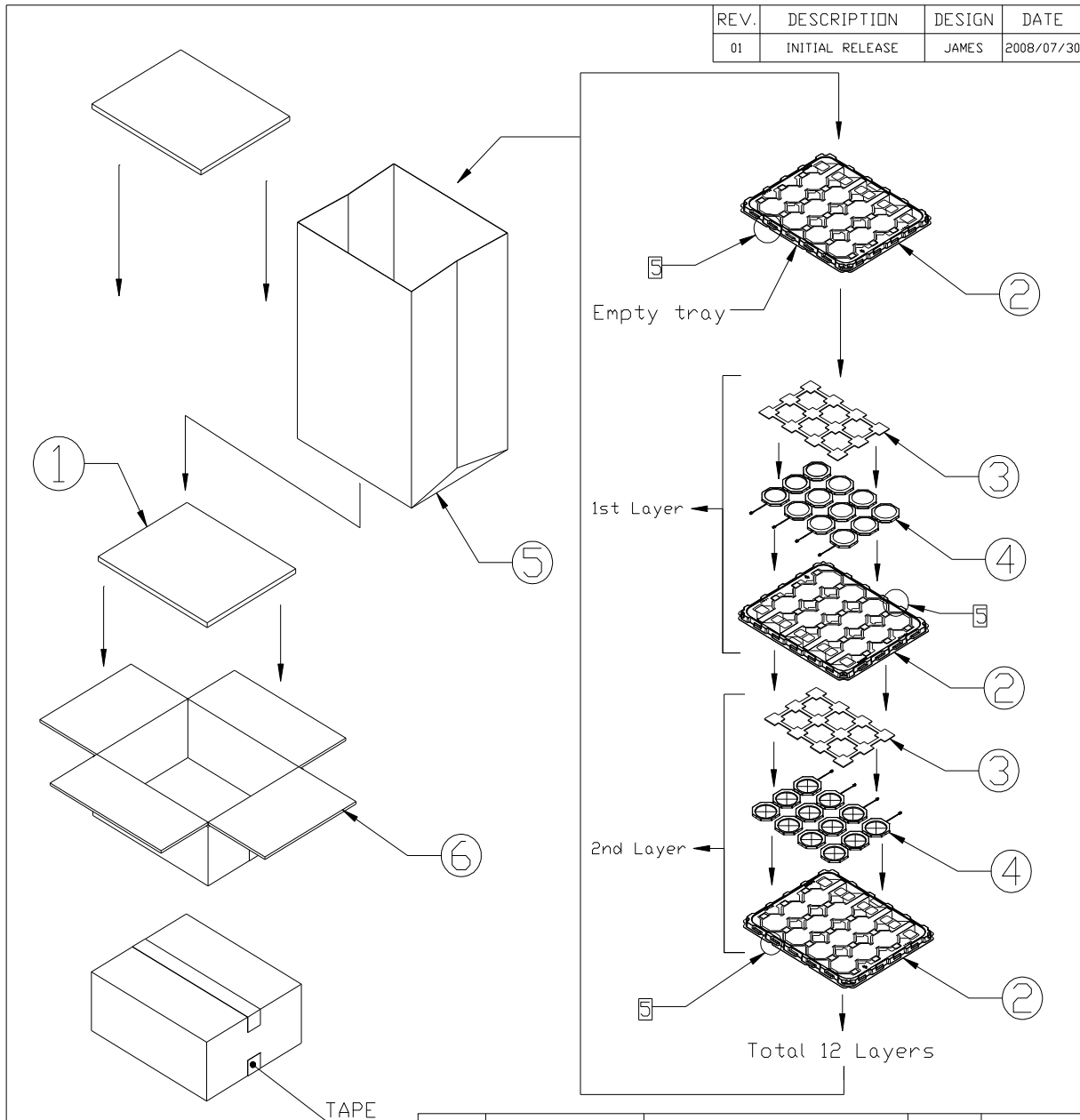

NOTE:
 1. ONE LAYER INCLUDE:1 PIECE OF CUSHION SHEET, 12 PCS MODULE & 1 PIECE OF TRAY.
 2. Q'TY:84 PCS PANEL/CARTON.
 3. DIMENSION: 455*375*190mm.
 4. WEIGHT: 6.0 Kg.
 5. TRAY 需180交叉堆疊, 疊堆後可從側邊檢視圓弧防呆方向是否正確

6	50-0100091	CARTON INTERNAL	1	
5	50-0500041	摺口袋 450*380*700mm	1	抗靜電
4		PO0230X1	84	
3	50-0210126	EPE CUSHION SHEET	7	抗靜電
2	50-0312101	TRAY	8	抗靜電
1	50-0300491	EPE FOAM	2	
ITEM	PART NO.	DESCRIPTION	Q'ty	REMARK

MTL.SPEC.		UNSPECIFIED TOL.		REMARK		 元太科技股份有限公司 Prime View International Co.,Ltd.	
		ANGLE					
		ROUGHNESS					
APPROVE	FRANK SHIN	SCALE	UNIT	SHEET	DWG.TITLE		
CHECK	FRANK SHIN			1 OF 2	2.3" ROUND MODULE PACKING DRAW		
DESIGN	JAMES	MTL.NO.		DWG.NO.		REV.	A4 SIZE
		PO0230X1				01	