

SPECIFICATION FOR TFT LCD MODULE

MODEL NO:	TM028HDZ30
CUSTOMER:	TME
CUSTOMER P/N.	
VERSION	V1.0
CUSTOMER APPROVED	

Preliminary Specification

Final Specification

PREPARED	CHECKED	VERIFIED BY QA DEPT	VERIFIED BY R&D DEPT

TIANMA MICRO-ELECTRONICS CO., LTD

Address: 8F, 64th Building, Jinlong, Majialong Industrial Area, Nanshan District, Shenzhen, China

Tel: +86-755-2609-4288

Fax: +86-755-8622-5774

+86-755-8622-5772

Web: www.tianma.cn www.tianma.com

REVISION RECORD

Date	Rev.No.	Page	Revision Items	Prepared
2011.4.1	V1.0		The first release	YL

CONTENTS

	Page
1.General Specifications -----	4
2. Outline Drawing -----	5
3. Circuit Block Diagram -----	6
4. Absolute Maximum Ratings -----	7
5. Electrical Specifications and Instruction Code -----	8
6. Optical Characteristics -----	18
7. Reliability Test Items and Criteria -----	22
8. Quality level-----	23
9. Precautions for Use of LCD Modules -----	28

1. General Specifications

TM028HDZ30 is a color active matrix LCD module incorporating **amorphous silicon** TFT (Thin Film Transistor). It is composed of a color TFT-LCD panel, driver IC, FPC and a back light unit. The **2.8"** display area contains **240 x 320** pixels and can display up to **262K** colors. This product accords with RoHS environmental criterion.

Item	Contents	Unit	Note
LCD Type	a-si TFT	-	
Display Color	65K/262K		1
LCD Duty	1/320	-	
Viewing Direction	6:00	O'Clock	
Active Area(W×H)	43.20×57.60	mm	
Number of Dots	240(RGB)×320	mm	
Dot Pitch(W×H)	0.180X0.180	mm	
Controller	ILI9335B	-	
V _{cc}	2.8	V	
I _{ovcc}	1.8/2.8	V	
Outline Dimensions	Refer to outline drawing on next page		
Backlight	4-LEDs(white parallel)	-	
Weight	17.4	g	
Interface	CPU 8/16 bits	-	
Polarizer Mode	Transmissive/Positive	-	

Note 1: Color tune is slightly changed by temperature and driving voltage.

Note 2: Requirements on Environmental Protection:RoHS

Note 3: Customer should do assembly according to our FPC bending sketch in the outline drawing.

Note 4: Please approve our spec before placing mass production order. Otherwise we will regard customer has approved the spec when we receive the first 2Kpcs or above order from customer.

2. Outline Drawing

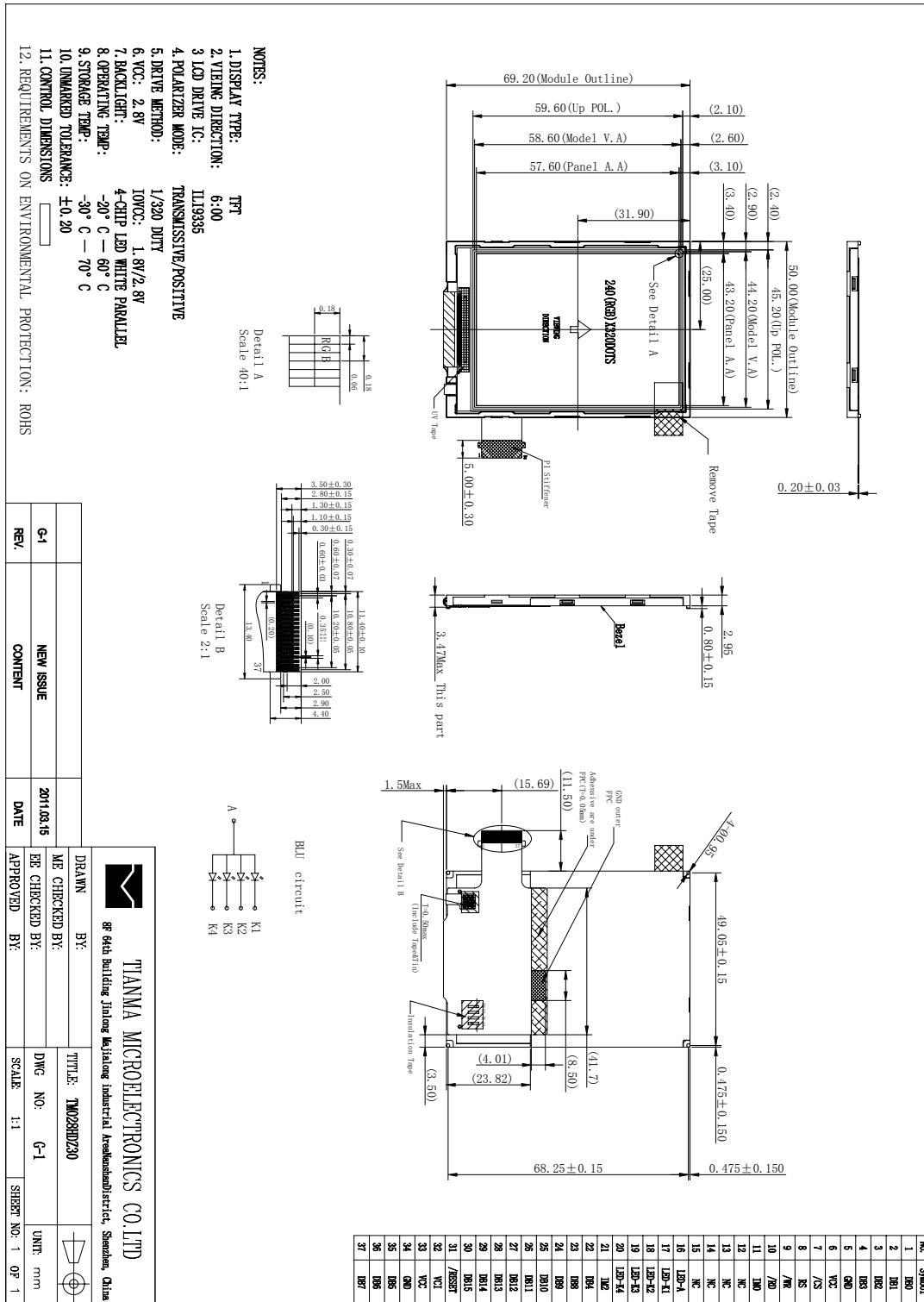

NOTE 1: FPC,BL,TP etc. may have not only one provider, appearance, silk-screen may exist difference.

NOTE 2: Customer's rind(handset rind etc.) and TIANMA's standard module may exist interference , Customer should advise on TIANM FAE or RD change rind.

3. Circuit Block Diagram

FPC INTERFACE

NO.	Symbol
1	DB0
2	DB1
3	DB2
4	DB3
5	GND
6	VCC
7	/CS
8	RS
9	/WR
10	/RD
11	IM0
12	NC
13	NC
14	NC
15	NC
16	LED-A
17	LED-K1
18	LED-K2
19	LED-K3
20	LED-K4
21	IM2
22	DB4
23	DB8
24	DB9
25	DB10
26	DB11
27	DB12
28	DB13
29	DB14
30	DB15
31	/RESET
32	VCI
33	VCC
34	GND
35	DB5
36	DB6
37	DB7

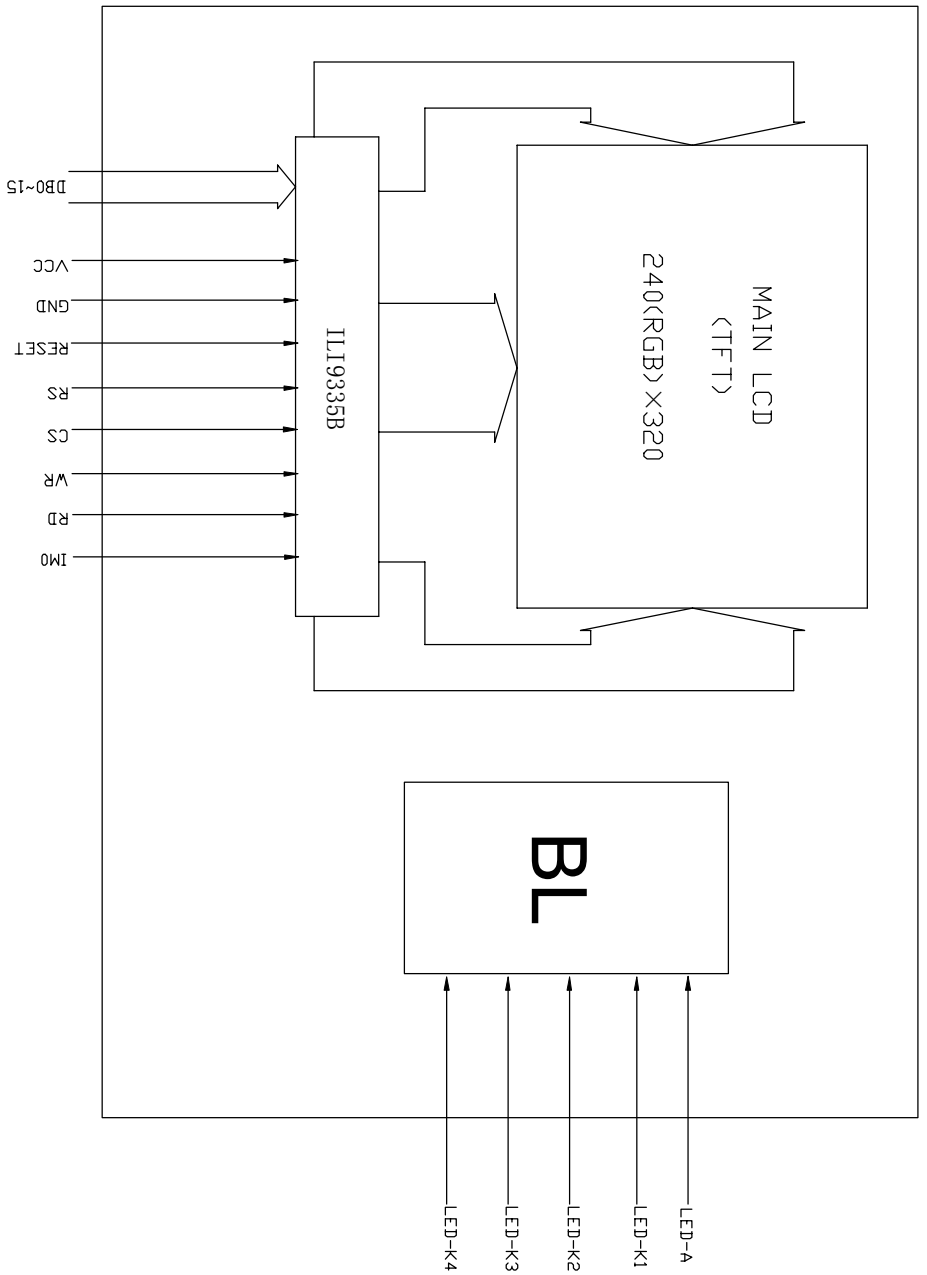

 <p>TIAN-MA MICROELECTRONICS CO.,LTD 8F, 64th Building, Jingdong Industrial Area, Nantian District, Shenzhen, China</p>		<p>DRAWN BY: _____</p> <p>CHECKED BY: _____</p> <p>APPROVED BY: _____</p>	
C-1	NEW	2011.4.1	
REV	DESCRIPTION	DATE	
PURPOSE: 电路图		UNIT: mm	SCALE: _____
		SHEET NO: 1 OF 1	

4. Absolute Maximum Ratings(Ta=25°C)

Item	Symbol	Min.	Max.	Unit	Note
Power Supply Voltage	V _{CC}	-0.3	4.6	V	1, 2
Logic Signal Input /Output Voltage	IOVCC	-0.3	4.6	V	
Operating Temperature	Top	-20	+60	°C	
Storage Temperature	Tst	-30	+70	°C	

Notes:

1. If the module is above these absolute maximum ratings. It may become permanently damaged.
Using the module within the following electrical characteristic conditions are also exceeded, the module will malfunction and cause poor reliability.
2. $V_{DD} > V_{SS}$ must be maintained.

5. Electrical Specifications and Instruction Code

5.1 Electrical characteristics(V_{ss}=0V ,Ta=25°C)

Parameter		Symbol	Condition	Min	Typ	Max	Unit	Note
Input voltage	‘H’	V _{IH}	IOVCC =1.65~3.6V	0.8 IOVCC	-	IOVCC	V	
	‘L’	V _{IL}	IOVCC =1.65~3.6V	-0.3	-	0.2 IOVCC	V	
Output Voltage	‘H’	V _{OH}	I _{OH} = -0.1 mA	0.8 IOVCC	-	-	V	
	‘L’	V _{OL}	IOVCC=1.65 ~3.6V	-	-	0.2 IOVCC	V	

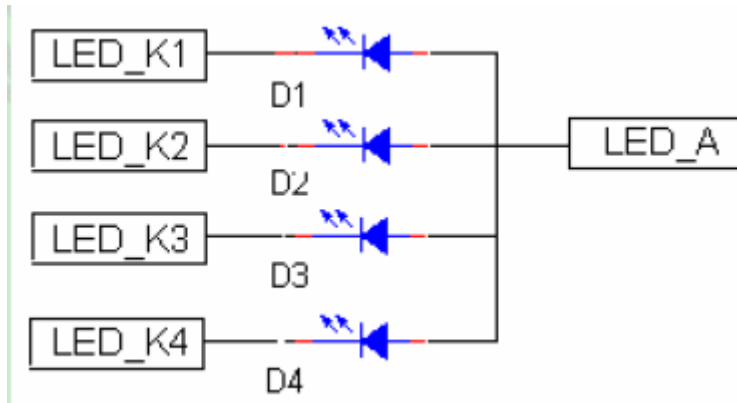
5.2 LED backlight specification(V_{SS}=0V ,T_a=25°C)

Item	Symbol	Min	Typ	Max	Unit	Condition	Note
Forward Voltage	V _F	2.9	3.2	3.5	V	I _f =80mA	
Luminance(9 point avg.)	L _a	3800	-	-	Cd/m ²	VR=5V	
Luminance Center	L _c	4200	4800	-	Cd/m ²	1. I _f =20mA/LED 2. Aperature:9 point 3. instrument is :BM-7A 4. Uniformity=min/max*100%	
Uniformity		80	-	-	%		
Color Coordinate	X	0.25	0.28	0.31			
	Y	0.24	0.27	0.30			

5.3 Interface Signals

Pin No.	Symbol	I/O	Description	Comment
1	D0	I/O	Data input	
2	D1	I/O	Data input	
3	D2	I/O	Data input	
4	D3	I/O	Data input	
5	GND	P	Ground	
6	VCC	P	Power Supply	
7	CS	I	Chip select signal(active low)	
8	RS	I	Register select signal. Low: select an index or status register High: select a control register	
9	WR	I	Write execution control pin	
10	RD	I	Read execution control pin	
11	IM0	I	Mode selection	Note 1
12	NC	-		
13	NC	-		
14	NC	-		
15	NC	-		
16	LED-A	P	LED anode	
17	LED-K1	P	LED cathode	
18	LED-K2	P	LED cathode	
19	LED-K3	P	LED cathode	
20	LED-K4	P	LED cathode	
21	IM2	I	Mode Selection(connect to GND)	
22	D4	I/O	Data input	
23	D8	I/O	Data input	
24	D9	I/O	Data input	
25	D10	I/O	Data input	
26	D11	I/O	Data input	
27	D12	I/O	Data input	
28	D13	I/O	Data input	
29	D14	I/O	Data input	
30	D15	I/O	Data input	
31	RESET	I	Reset pin(active at low)	
32	VCI	P	Analog power supply	
33	VCC	P	Logic power supply	
34	GND	P	Ground	
35	D5	I/O	Data input	
36	D6	I/O	Data input	
37	D7	I/O	Data input	

Note 1:

IM0	MCU Interface Mode	Data bus
0	16 bit	DB[15:0]
1	8 bit	DB[15:8]

5.4 Interface Timing Chart

Note: Please refer to ILITEK's [ILI9335B](#) data sheet for more details.

ILITEK's [ILI9335B](#) interface protocol

5.4.1 Interface Timing Parameters & Interface Characteristics

Normal Write Mode (IOVCC = 1.65~3.6V)

Item	Symbol	Unit	Min.	Typ.	Max.	Test Condition
Bus cycle time	Write	t_{CYW}	ns	(75)	-	-
	Read	t_{CYR}	ns	300	-	-
Write low-level pulse width	PW_{LW}	ns	(40)	-	500	-
Write high-level pulse width	PW_{HW}	ns	(30)	-	-	-
Read low-level pulse width	PW_{LR}	ns	150	-	-	-
Read high-level pulse width	PW_{HR}	ns	150	-	-	-
nCS/ RS/ DB Write / Read rise / fall time	t_{WRr}/t_{WRf}	ns	-	-	25	-
Setup time	Write (RS to nCS, E/nWR)	t_{AS}	ns	10	-	-
	Read (RS to nCS, RW/nRD)			5	-	-
Address hold time	t_{AH}	ns	5	-	-	
Write data set up time	t_{DSW}	ns	10	-	-	
Write data hold time	t_H	ns	15	-	-	
Read data delay time	t_{DDR}	ns	-	-	100	
Read data hold time	t_{DHR}	ns	5	-	-	

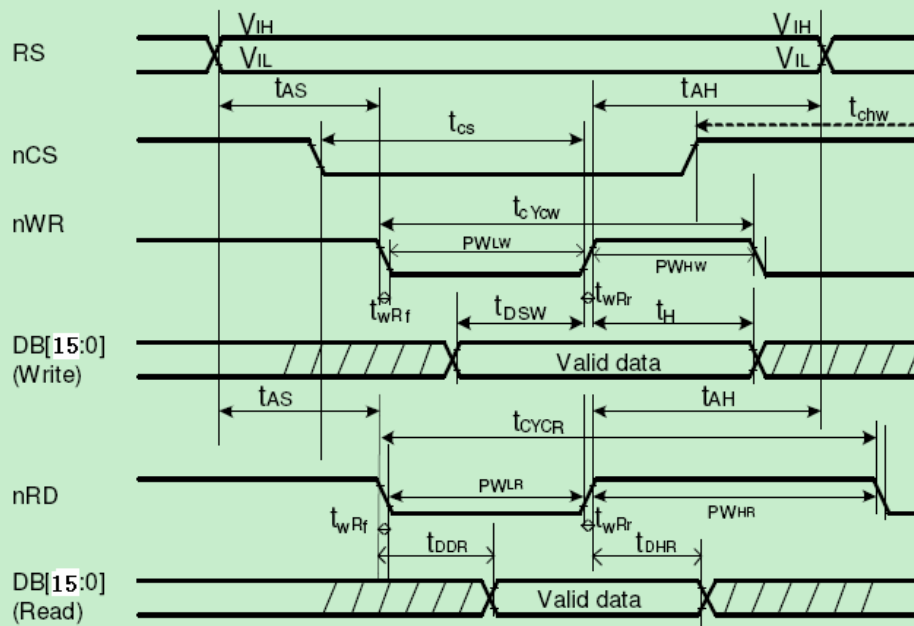

5.4.2 Instruction Description (ILITEK's ILI9335B)

8.2. Instruction Descriptions

No.	Registers Name	R/W	RS	D15	D14	D13	D12	D11	D10	D9	D8	D7	D6	D5	D4	D3	D2	D1	D0	
IR	Index Register	W	0	-	-	-	-	-	-	-	-	ID7	ID6	ID5	ID4	ID3	ID2	ID1	ID0	
00h	Driver Code Read	RO	1	1	0	0	1	0	0	1	0	0	0	1	1	0	1	0	1	
01h	Driver Output Control 1	W	1	0	0	0	0	0	SM	0	SS	0	0	0	0	0	0	0	0	
02h	LCD Driving Control	W	1	0	0	0	0	0	0	B/C	0	0	0	0	0	0	0	0	0	
03h	Entry Mode	W	1	TRI	DFM	0	BGR	0	0	0	0	ORG	0	I/D1	I/D0	AM	0	0	0	
05h	16 bits data format control	W	1	0	0	0	0	0	0	0	0	0	0	0	0	0	0	EPF1	EPF0	
07h	Display Control 1	W	1	0	0	PTDE1	PTDE0	0	0	0	BASEE	0	0	GON	DTE	CL	0	D1	D0	
08h	Display Control 2	W	1	FP7	FP6	FP5	FP4	FP3	FP2	FP1	FP0	BP7	BP6	BP5	BP4	BP3	BP2	BP1	BP0	
09h	Display Control 3	W	1	0	0	0	0	0	0	PTS1	PTS0	0	0	PTG1	PTG0	ISC3	ISC2	ISC1	ISC0	
0Ah	Display Control 4	W	1	0	0	0	0	0	0	0	0	0	0	0	0	FMARKOE	FMI2	FMI1	FMI0	
0Ch	RGB Display Interface Control 1	W	1	0	ENC2	ENC1	ENC0	0	0	0	RM	0	0	DM1	DM0	0	0	RIM1	RIM0	
0Dh	Frame Maker Position	W	1	0	0	0	0	0	0	0	FMP8	FMP7	FMP6	FMP5	FMP4	FMP3	FMP2	FMP1	FMP0	
0Fh	RGB Display Interface Control 2	W	1	0	0	0	0	0	0	0	0	0	0	VSPL	HSPL	0	EPL	DPL	0	
10h	Power Control 1	W	1	0	0	0	SAP	0	BT2	BT1	BT0	APE	AP2	AP1	AP0	0	0	SLP	STB	
11h	Power Control 2	W	1	0	0	0	0	0	DC12	DC11	DC10	0	DC02	DC01	DC00	0	VC2	VC1	VC0	
12h	Power Control 3	W	1	0	0	0	0	0	0	0	0	VCIRE	0	0	0	VRH3	VRH2	VRH1	VRH0	
13h	Power Control 4	W	1	0	0	0	VDV4	VDV3	VDV2	VDV1	VDV0	0	0	0	0	0	0	0	0	
20h	Horizontal GRAMA Address Set	W	1	0	0	0	0	0	0	0	0	AD7	AD6	AD5	AD4	AD3	AD2	AD1	AD0	
21h	Vertical GRAMA Address Set	W	1	0	0	0	0	0	0	0	AD16	AD15	AD14	AD13	AD12	AD11	AD10	AD9	AD8	
22h	Write Data to GRAM	W	1	RAM write data (WD17-0) / read data (RD17-0) bits are transferred via different data bus lines according to the selected interfaces.																
29h	Power Control 7	W	1	0	0	0	0	0	0	0	0	0	0	VCM5	VCM4	VCM3	VCM2	VCM1	VCM0	
2Bh	Frame Rate and Color Control	W	1	0	0	0	0	0	0	0	0	0	0	0	0	FRS[3]	FRS[2]	FRS[1]	FRS[0]	
30h	Gamma Control 1	W	1	0	0	0	0	0	KP1[2]	KP1[1]	KP1[0]	0	0	0	0	0	KP0[2]	KP0[1]	KP0[0]	
31h	Gamma Control 2	W	1	0	0	0	0	0	KP3[2]	KP3[1]	KP3[0]	0	0	0	0	0	KP2[2]	KP2[1]	KP2[0]	
32h	Gamma Control 3	W	1	0	0	0	0	0	KP5[2]	KP5[1]	KP5[0]	0	0	0	0	0	KP4[2]	KP4[1]	KP4[0]	
35h	Gamma Control 4	W	1	0	0	0	0	0	RP1[2]	RP1[1]	RP1[0]	0	0	0	0	0	RP0[2]	RP0[1]	RP0[0]	
36h	Gamma Control 5	W	1	0	0	0	VRP1[4]	VRP1[3]	VRP1[2]	VRP1[1]	VRP1[0]	0	0	0	0	0	VRP0[3]	VRP0[2]	VRP0[1]	VRP0[0]
37h	Gamma Control 6	W	1	0	0	0	0	0	KN1[2]	KN1[1]	KN1[0]	0	0	0	0	0	KN0[2]	KN0[1]	KN0[0]	
38h	Gamma Control 7	W	1	0	0	0	0	0	KN3[2]	KN3[1]	KN3[0]	0	0	0	0	0	KN2[2]	KN2[1]	KN2[0]	
39h	Gamma Control 8	W	1	0	0	0	0	0	KN5[2]	KN5[1]	KN5[0]	0	0	0	0	0	KN4[2]	KN4[1]	KN4[0]	
3Ch	Gamma Control 9	W	1	0	0	0	0	0	RN1[2]	RN1[1]	RN1[0]	0	0	0	0	0	RN0[2]	RN0[1]	RN0[0]	

No.	Registers Name	R/W	RS	D15	D14	D13	D12	D11	D10	D9	D8	D7	D6	D5	D4	D3	D2	D1	D0
3Dh	Gamma Control 10	W	1	0	0	0	VRN1[4]	VRN1[3]	VRN1[2]	VRN1[1]	VRN1[0]	0	0	0	0	VRN0[3]	VRN0[2]	VRN0[1]	VRN0[0]
50h	Horizontal Address Start Position	W	1	0	0	0	0	0	0	0	0	HSA7	HSA6	HSA5	HSA4	HSA3	HSA2	HSA1	HSA0
51h	Horizontal Address End Position	W	1	0	0	0	0	0	0	0	0	HEA7	HEA6	HEA5	HEA4	HEA3	HEA2	HEA1	HEA0
52h	Vertical Address Start Position	W	1	0	0	0	0	0	0	0	VSA8	VSA7	VSA6	VSA5	VSA4	VSA3	VSA2	VSA1	VSA0
53h	Vertical Address End Position	W	1	0	0	0	0	0	0	0	VEA8	VEA7	VEA6	VEA5	VEA4	VEA3	VEA2	VEA1	VEA0
60h	Driver Output Control 2	W	1	GS	0	NL5	NL4	NL3	NL2	NL1	NL0	0	0	SCN5	SCN4	SCN3	SCN2	SCN1	SCN0
61h	Base Image Display Control	W	1	0	0	0	0	0	0	0	0	0	0	0	0	0	NDL	VLE	REV
6Ah	Vertical Scroll Control	W	1	0	0	0	0	0	0	0	VL8	VL7	VL6	VL5	VL4	VL3	VL2	VL1	VL0
80h	Partial Image 1 Display Position	W	1	0	0	0	0	0	0	0	PTDP08	PTDP07	PTDP06	PTDP05	PTDP04	PTDP03	PTDP02	PTDP01	PTDP00
81h	Partial Image 1 Area (Start Line)	W	1	0	0	0	0	0	0	0	PTSA08	PTSA07	PTSA06	PTSA05	PTSA04	PTSA03	PTSA02	PTSA01	PTSA00
82h	Partial Image 1 Area (End Line)	W	1	0	0	0	0	0	0	0	PTEA08	PTEA07	PTEA06	PTEA05	PTEA04	PTEA03	PTEA02	PTEA01	PTEA00
83h	Partial Image 2 Display Position	W	1	0	0	0	0	0	0	0	PTDP18	PTDP17	PTDP16	PTDP15	PTDP14	PTDP13	PTDP12	PTDP11	PTDP10
84h	Partial Image 2 Area (Start Line)	W	1	0	0	0	0	0	0	0	PTSA18	PTSA17	PTSA16	PTSA15	PTSA14	PTSA13	PTSA12	PTSA11	PTSA10
85h	Partial Image 2 Area (End Line)	W	1	0	0	0	0	0	0	0	PTEA18	PTEA17	PTEA16	PTEA15	PTEA14	PTEA13	PTEA12	PTEA11	PTEA10
90h	Panel Interface Control 1	W	1	0	0	0	0	0	0	DIV1	DIV0	0	0	0	RTN4	RTN3	RTN2	RTN1	RTN0
92h	Panel Interface Control 2	W	1	0	0	0	0	0	NOW12	NOW11	NOW10	0	0	0	0	0	0	0	0
95h	Panel Interface Control 4	W	1	0	0	0	0	0	0	DIVE1	DIVE0	0	0	0	0	0	0	0	0
97h	Panel Interface Control 5	W	1	0	0	0	0	0	NOWE3	NOWE2	NOWE1	NOWE0	0	0	0	0	0	0	0
A1h	OTP VCM Programming Control	W	1	0	0	0	0	OTP_PGM_EN	0	0	0	0	0	VCM_OTP5	VCM_OTP4	VCM_OTP3	VCM_OTP2	VCM_OTP1	VCM_OTP0
A2h	OTP VCM Status and Enable	W	1	PGM_CNT1	PGM_CNT0	VCM_D5	VCM_D4	VCM_D3	VCM_D2	VCM_D1	VCM_D0	0	0	0	0	0	0	0	VCM_EN
A4h	OTP for ID code writing	W	1	TEST_OTP_EN	0	OTP_SEL1	OTP_SEL2	0	1	0	0	0	0	0	0	0	0	0	0
A5h	OTP Programming ID Key	W	1	KEY_15	KEY_14	KEY_13	KEY_12	KEY_11	KEY_10	KEY_9	KEY_8	KEY_7	KEY_6	KEY_5	KEY_4	KEY_3	KEY_2	KEY_1	KEY_0
E6h	Deep stand by mode control	W	1	0	0	0	0	0	0	0	0	0	0	0	0	0	0	0	DSTB

5.4.3 Interface Register write/read timing

I80 8-bit System Bus Interface Timing



I80 16-bit System Bus Interface Timing

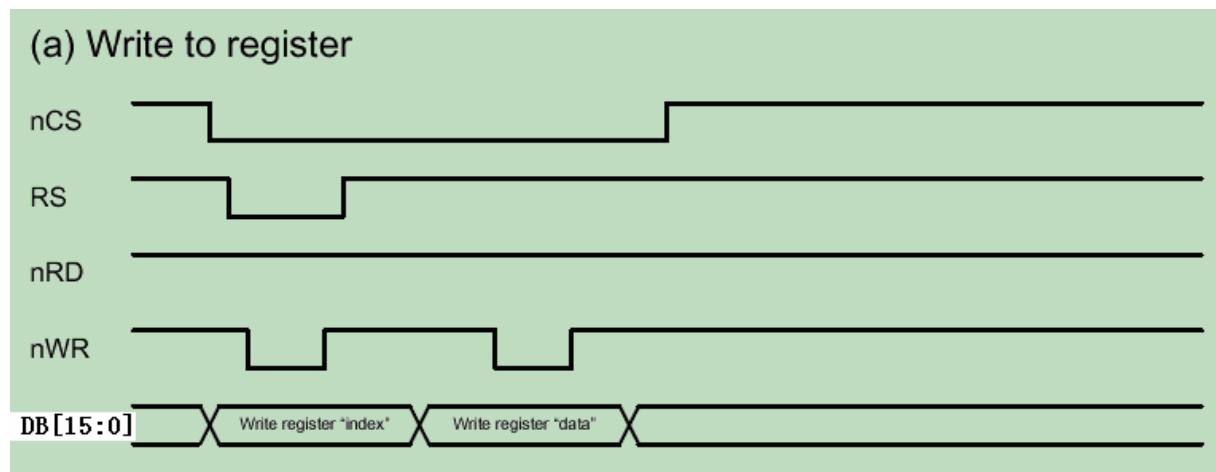

(b) Read from register

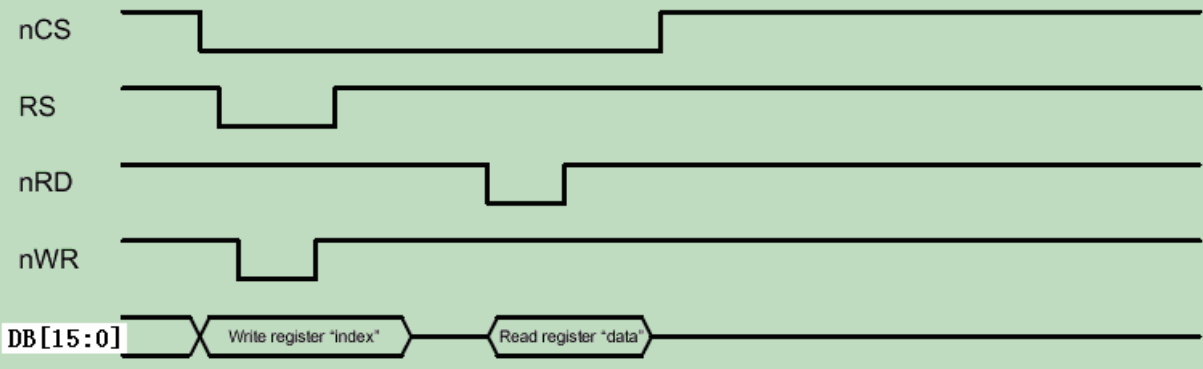

5.4.4 i80-System Interface Data Format

a) i80-System Interface with 8-bit Data Bus

TRI	DFM	8-bit MPU System Interface Data Format
0	*	<p>system 8-bit interface (2 transfers/pixel) 65,536 colors</p>
1	0	<p>80-system 8-bit interface (3 transfers/pixel) 262,144 colors</p>
1	1	<p>80-system 8-bit interface (3 transfers/pixel) 262,144 colors</p>

b) i80-System Interface with 16-bit Data Bus

TRI	DFM	16-bit MPU System Interface Data Format
0	*	<p>system 16-bit interface (1 transfers/pixel) 65,536 colors</p>
1	0	<p>80-system 16-bit interface (2 transfers/pixel) 262,144 colors</p>
1	1	<p>80-system 16-bit interface (2 transfers/pixel) 262,144 colors</p>

5.4.5 Data Bus GRAM Write/Read Timing

a) GRAM Timing of i80 8-bit System Interface

(a) Write to GRAM

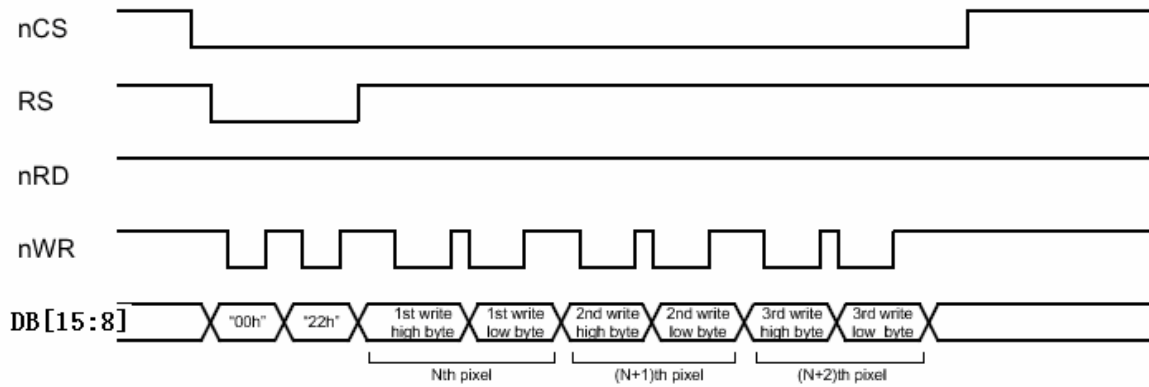

(b) Read from GRAM

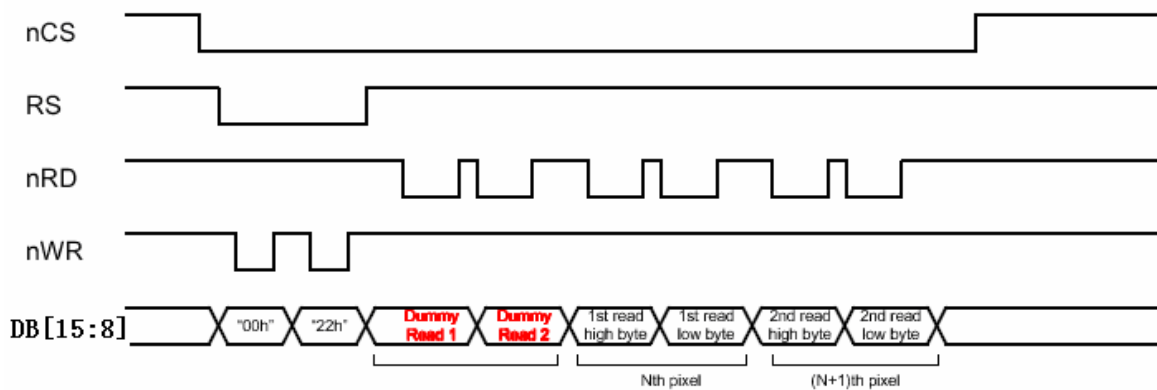

b) GRAM Timing of i80 16-bit System Interface

(a) Write to GRAM

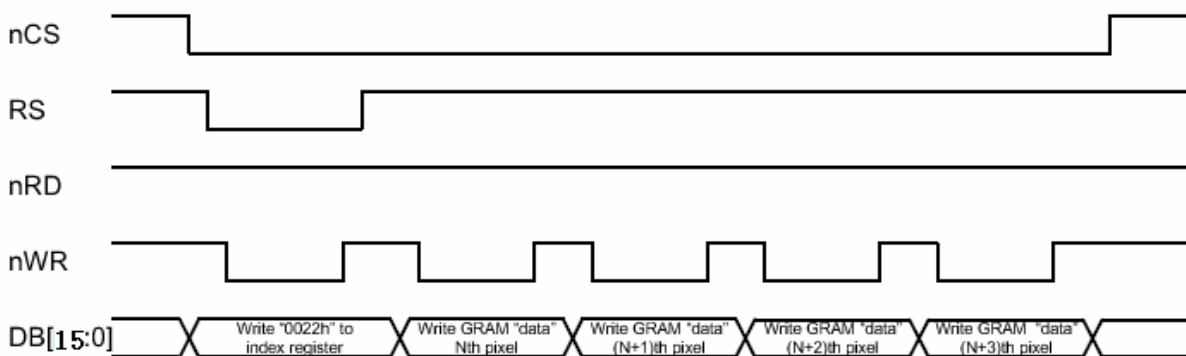

(b) Read from GRAM

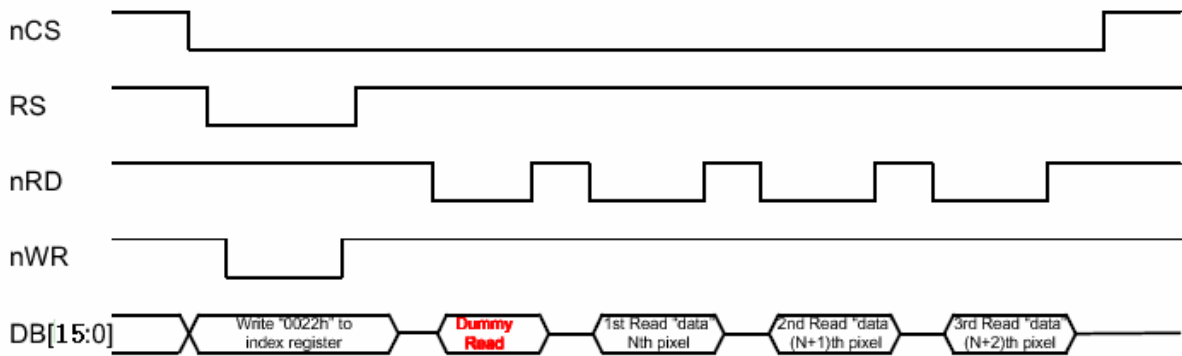

5.4.6 Reset Timing Characteristics

Reset Timing Characteristics (IOVCC = 1.65 ~ 3.6 V)

Item	Symbol	Unit	Min.	Typ.	Max.
Reset low-level width	t_{RES_L}	ms	1	-	-
Reset rise time	t_{RES}	μ s	-	-	10
Reset high-level width	t_{RES_H}	ms	50	-	-



6. Optical Characteristics

Item	Symbol	Condition	Min.	Typ.	Max.	Unit	Note
Brightness	Bp	$\theta=0^\circ$	190	210	-	Cd/m ²	1
Uniformity	ΔBp	$\Phi=0^\circ$	-	80%	-		1,2
Viewing Angle	θ_1 ($\Phi=90^\circ$)	Cr \geq 10	60	70	-	Deg	3
	θ_1 ($\Phi=270^\circ$)		50	60	-		
	θ_2 ($\Phi=0^\circ$)		60	70	-		
	θ_2 ($\Phi=180^\circ$)		60	70	-		
Contrast Ratio	Cr	$\theta=0^\circ$	300	350	-	-	4
Response Time	T _r	25°C	-	20	30	ms	5
	T _f						
Color of CIE Coordinate	W	x	0.254	0.304	0.354	-	1,6
		y	0.313	0.363	0.413	-	
	R	x	0.560	0.610	0.660	-	
		y	0.284	0.334	0.384	-	
	G	x	0.246	0.296	0.346	-	
		y	0.508	0.558	0.608	-	
	B	x	0.080	0.130	0.180	-	
		y	0.114	0.164	0.214	-	
NTSC Ratio	S	$\theta=0^\circ$ $\Phi=0^\circ$	-	50%			

Note: The parameter is slightly changed by temperature, driving voltage and materiel.

Note 1: The data are measured after LEDs are turned on for 5 minutes. LCM displays full white. The brightness is the average value of 9 measured spots. Measurement equipment PR-705 (Φ 8mm)

Measuring condition:

- Measuring surroundings: Dark room.
- Measuring temperature: Ta=25°C.
- Adjust operating voltage to get optimum contrast at the center of the display.

Measured value at the center point of LCD panel after more than 5 minutes while backlight turning on.

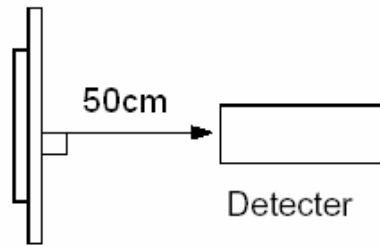

Note 2: The luminance uniformity is calculated by using following formula.

$$\Delta B_p = B_p (\text{Min.}) / B_p (\text{Max.}) \times 100 (\%)$$

$B_p (\text{Max.})$ = Maximum brightness in 9 measured spots

$B_p (\text{Min.})$ = Minimum brightness in 9 measured spots.

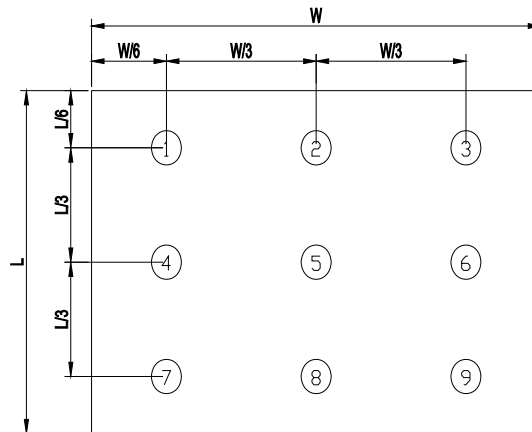

Measurement equipment PR-705 ($\Phi 8\text{mm}$)

Note 3: The definition of viewing angle:

Refer to the graph below marked by θ and ϕ

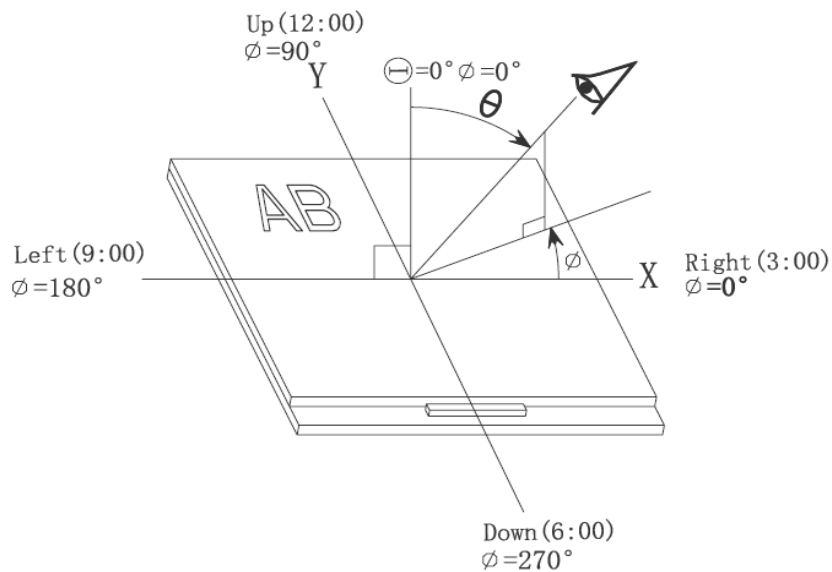

Note 4: The definition of contrast ratio (Test LCM using PR-705):

$$\text{Contrast Ratio(CR)} = \frac{\text{Luminance When LCD is at "White" state}}{\text{Luminance When LCD is at "Black" state}}$$

(Contrast Ratio is measured in optimum common electrode voltage)

Note 5: Definition of Response time. (Test LCD using DMS501):

The output signals of photo detector are measured when the input signals are changed from "black" to "white"(falling time) and from "white" to "black"(rising time), respectively. The response time is defined as the time interval between the 10% and 90% of amplitudes.Refer to figure as below.

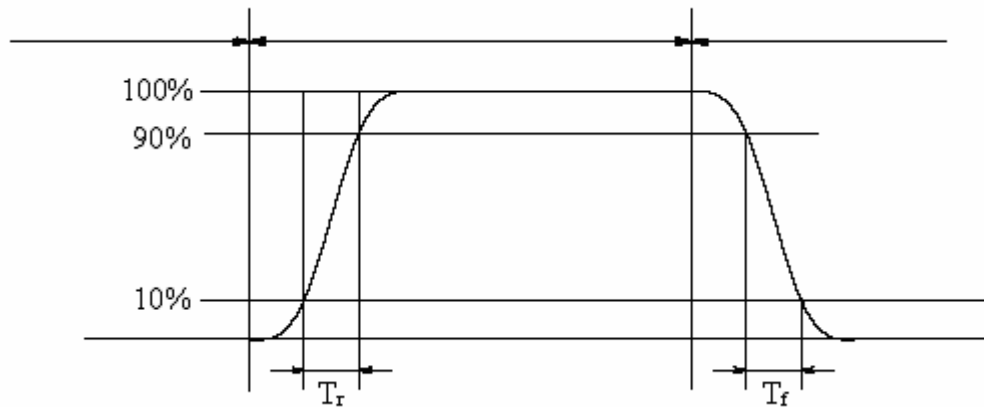

The definition of response time

Note 6: Definition of Color of CIE Coordinate and NTSC Ratio.

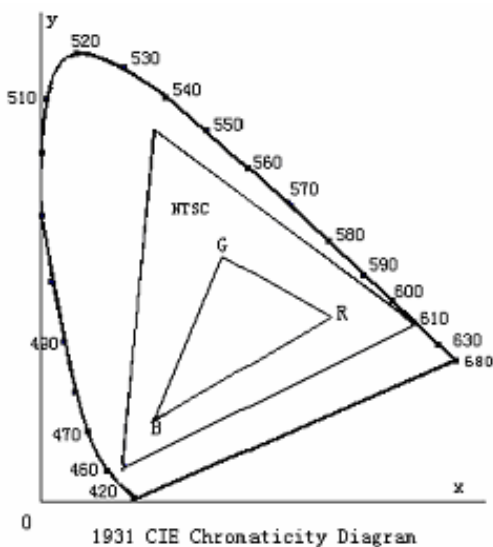

Color gamut:

$$S = \frac{\text{area of RGB triangle}}{\text{area of NTSC triangle}} \times 100\%$$

7. Reliability Test Items and Criteria

No	Test Item	Test condition	Criterion
1	High Temperature Storage	Ta=+70°C,240hrs	After testing, cosmetic and electrical defects should not happen.
2	Low Temperature Storage	Ta=-30°C,240hrs	
3	High Temperature Operation	Ts=+60°C,240hrs	
4	Low Temperature Operation	Ta=-20°C,240hrs	
5	High Temperature & Humidity Operation	Ta=+60°C±2°C 90%RH 240H Power on	
6	Thermal Shock(Non-operation)	-30°C 30 min~+70°C 30 min,Change time:5 min,20 Cycles	
7	Vibration Test(Non-operation)	Frequency range:10~55Hz Stroke:1.5mm Sweep:10Hz~55Hz~10Hz 2 hours For each direction of X,Y,Z. (6 hours for total)(Package condition)	
8	Shock Test(Non-operation)	60G 6ms,±X, ±Y, ±Z 3 times, for each direction	
9	Drop Test(package state)	Height:80 cm,1corner, 3edges, 6 sides each time	1.After testing, cosmetic and electrical defects should not happen. 2.the product should remain at initial place 3.Product uncovered or package broken is not permitted.

Note 1:Ts is the temperature of panel's surface.

Note 2:Ta is the ambient temperature of sample.

Note 3:Additional test Item proposed by customer shall be determined by mutual agreement between customer and Tianma

8 Quality level

8.1 Classification of defects

Major defects (MA): A major defect refers to a defect that may substantially degrade usability for product applications, including all functional defects(such as no display, abnormal display, open or missing segment, short circuit, missing component), outline dimension beyond the drawing, progressive defects and those affecting reliability.

Minor defects (MI): A minor defect refers to a defect which is not considered to be able to substantially degrade the product application or a defect that deviates from existing standards almost unrelated to the effective use of the product or its operation, such as black spot, white spot, bright spot, pinhole, black line, white line, contrast variation, glass defect, polarizer defect, etc.

8.2 Definition of inspection range

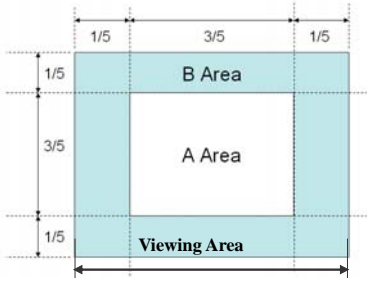
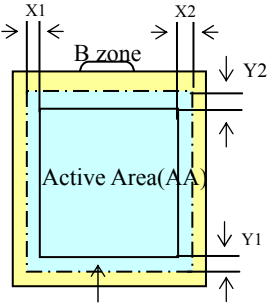
<p>For dot defect of TFT LCD which is not smaller than 3 inches, dividing three areas to make a judgment (according to figure 1).</p> <p>A area : center of viewing area B area : periphery of viewing area C area : Outside viewing area</p> <p>For other defects, dividing two areas to make a judgment (according to figure 2).</p> <p>A zone : Inside Viewing area B zone : Outside Viewing area</p> <p>X1(A.A~V.A): -mm X2(A.A~V.A):-mm Y1(A.A~V.A): -mm Y2(A.A~V.A): -mm</p>	 <p>Figure 1</p>  <p>Figure 2</p>
--	--

8.3 Inspection items and general notes

General notes	<p>①Should any defects which are not specified in this standard happen, additional standard shall be determined by mutual agreement between customer and TIANMA.</p> <p>②Viewing area should be the area which TIANMA guarantees.</p> <p>③Limit sample should be prior to this Inspection standard.</p> <p>④Viewing judgment should be under static pattern.</p> <p>⑤Inspection conditions</p> <p style="text-align: center;">Inspection distance: 250 mm (from the sample) Temperature : 25±5 °C</p> <p style="text-align: center;">Inspection angle : 45 degrees in 6 o'clock direction (all defects in viewing area should be inspected from this direction)</p>	
Inspection items	Pinhole, Bright spot, Black spot, White spot, Black line, White Line, Foreign particle, Bubble	The color of a small area is different from the remainder. The phenomenon doesn't change with voltage
	Contrast variation	The color of a small area is different from the remainder. The phenomenon changes with voltage
	Polarizer defect	Scratch, Dirt, Particle, Bubble on polarizer or between polarizer and glass
	Dot defect (TFT LCD)	The pixel appears bright or dark abnormally when display
	Functional defect	No display, Abnormal display, Open or missing segment, Short circuit, False viewing direction
	Glass defect	Glass crack, Shaved corner of glass, Surplus glass
	PCB defect	Components assembly defect

8.4 Outgoing Inspection level

Outgoing Inspection standard	Inspection conditions	Inspection				
		Min.	Max.	Unit	IL	AQL
Major Defects	See 8.3 general notes	See 8.5			II	0.65
Minor Defects	See 8.3 general notes	See 8.5			II	1.5

Note: Sampling standard conforms to GB2828

8.5 Inspection Items and Criteria

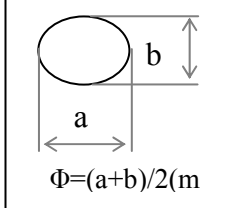
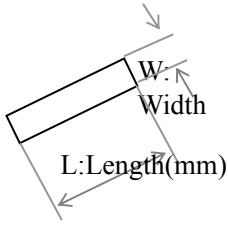
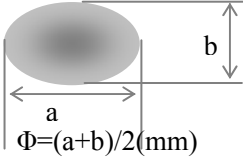
Inspection items		Judgment standard					
		Category		Acceptable number			
				A zone	B zone		
1	Black spot, White spot, Bright Spot, Pinhole, Foreign Particle, Particle in or on glass, Scratch on glass		A	$\Phi \leq 0.10$	Neglected		
			B	$0.10 < \Phi \leq 0.15$	2		
			C	$0.15 < \Phi \leq 0.20$	1		
			D	$0.20 < \Phi$	0		
			Total defective point(B,C)		3		Neglected
2	Black line, White line, and Particle Between Polarizer and glass, Scratch on glass		A	$W \leq 0.01$	Neglected		
			B	$0.01 < W \leq 0.03$ $L \leq 3.0$	2		
			C	$0.03 < W \leq 0.05$ $L \leq 3.0$	1		
			D	$0.05 < W$	0		
			Total defective point(B,C)		3		Neglected
3	Contrast variation		A	$\Phi \leq 0.2$	Neglected		
			B	$0.2 < \Phi \leq 0.3$	2		
			C	$0.3 < \Phi \leq 0.4$	1		
			D	$0.4 < \Phi$	0		
			Total defective point(B,C)		3		Neglected
4	Dot defect (if TFT LCD is used)	TFT LCD is smaller than 3 inches	LCD Class	Defect	A area		B area
			A	Bright dot	1		Neglected
				Dark dot	1		
		Total		2			
		TFT LCD between 3~10.4 inches	LCD Class	Defect	A area	B area	C area
B	Bright dot		2	2	Neglected		
	Dark dot	2	3				

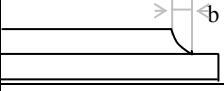
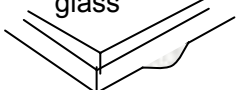
				Total	6	d
		Notes: Bright dot: in R、G、B or dark display figure, the pixel appears bright. Dark dot: in R、G、B or white display figure, the pixel appears dark. Defect area must be less than an half size of the dot. The distance of two dot: L>5mm.				
5	Bubble inside cell		any size		none	none
6	Polarizer defect (if Polarizer is used)	Scratch ,damage on polarizer, Particle on polarizer or between polarizer and glass.	Refer to item 1 and item 2.			
		Bubble, dent and convex	A	$\Phi \leq 0.3$	Neglected	Neglected
			B	$0.3 < \Phi \leq 0.7$	2	
			C	$0.7 < \Phi$	0	
7	Surplus glass	Stage surplus glass 	$b \leq 0.3\text{mm}$			
		Surrounding surplus glass 	Should not influence outline dimension and assembling.			
8	Open segment or open common	Not permitted				
9	Short circuit	Not permitted				
10	False viewing direction	Not permitted				
11	Contrast ratio uneven	According to the limit specimen				
12	Crosstalk	According to the limit specimen				
13	Black /White spot(display)	Refer to item 1				
14	Black /White line(display)	Refer to item 2				

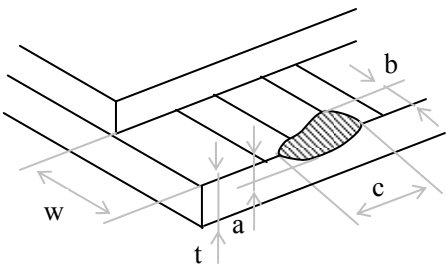
Inspection items		Judgment standard		
		Category(application: B zone)	Acceptable number	
15	Glass defect crack ①The front of lead terminals 	A	$a \leq t, b \leq 1/5W, c \leq 3\text{mm}$	Max.3 defects allowed
		B	Crack at two sides of lead terminals should not cover patterns and alignment mark	

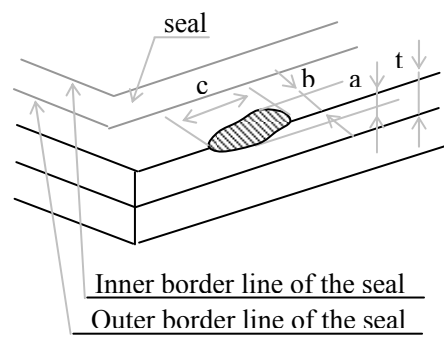
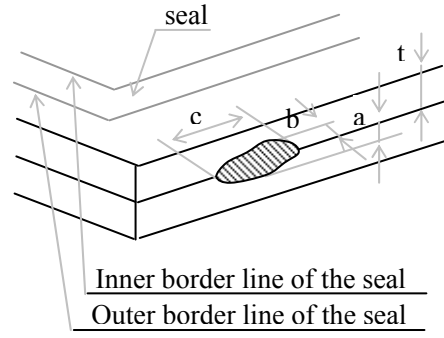
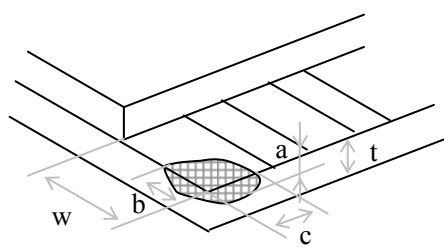
		<p>② Surrounding crack—non-contact side</p>  <p>Inner border line of the seal Outer border line of the seal</p>	<p>$b < \text{Inner border line of the seal}$</p>					
		<p>③ Surrounding crack—contact side</p>  <p>Inner border line of the seal Outer border line of the seal</p>	<p>$b < \text{Outer border line of the seal}$</p>					
		<p>④ Corner</p> 	<table border="1"> <tr> <td data-bbox="901 1052 949 1108">A</td> <td data-bbox="949 1052 1364 1108">$a \cong t, b \cong 3.0, c \cong 3.0$</td> </tr> <tr> <td data-bbox="901 1108 949 1442">B</td> <td data-bbox="949 1108 1364 1442">Glass crack should not cover patterns u and alignment mark and patterns.</td> </tr> </table>	A	$a \cong t, b \cong 3.0, c \cong 3.0$	B	Glass crack should not cover patterns u and alignment mark and patterns.	
A	$a \cong t, b \cong 3.0, c \cong 3.0$							
B	Glass crack should not cover patterns u and alignment mark and patterns.							

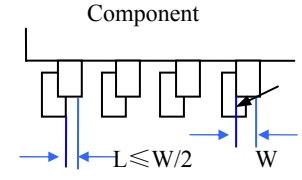
Inspection items		Judgment standard
		Category(application: B zone)
16	<p>PCB defect</p> <p>Component soldering: No cold soldering, short, open circuit, burr, tin ball The flat encapsulation component position deviation must be less than 1/3 width of the pin (Pic.1); the sheet component deviation: Pin deviates from the pad and contact with the near components is not permitted (Pic.2)</p>	

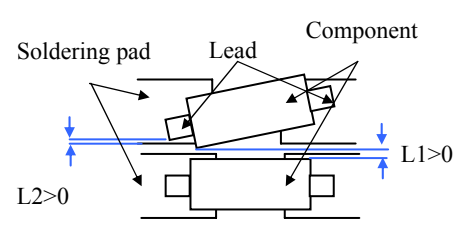
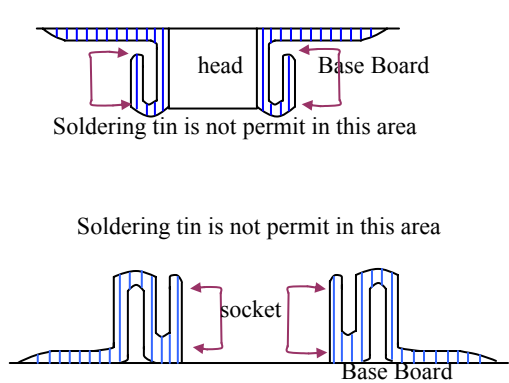
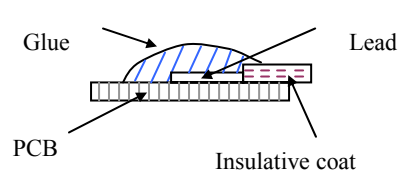
	<p>lead defect: The lead lack must be less than 1/3 of its width; The lead burr must be less than 1/3 of the seam; Impurities connect with the near leads is not permitted</p>	
	<p>Connector soldering: Soldering tin is at contact position of the plug and socket is not permitted No foundation is scald Serious cave distortion on plug and socket contact pin is not permitted</p>	
	<p>Glue on root of the speaker receiver and motor lead: The insulative coat of the lead must join into the PCB; the protected glue must envelop to the insulative coat.</p>	

9. Precautions for Use of LCD Modules

9.1 Handling Precautions

9.1.1 The display panel is made of glass. Do not subject it to a mechanical shock by dropping it from a high place, etc.

9.1.2 If the display panel is damaged and the liquid crystal substance inside it leaks out, be sure not to get any in your mouth, if the substance comes into contact with your skin or clothes, promptly wash it off using soap and water.

9.1.3 Do not apply excessive force to the display surface or the adjoining areas since this may cause the color tone to vary.

9.1.4 The polarizer covering the display surface of the LCD module is soft and easily scratched. Handle this polarizer carefully.

9.1.5 If the display surface is contaminated, breathe on the surface and gently wipe it with a soft dry cloth. If still not completely clear, moisten cloth with one of the following solvents:

- Isopropyl alcohol
- Ethyl alcohol

Solvents other than those mentioned above may damage the polarizer.

Especially, do not use the following:

- Water
- Ketone
- Aromatic solvents

9.1.6 Do not attempt to disassemble the LCD Module.

9.1.7 If the logic circuit power is off, do not apply the input signals.

9.1.8 To prevent destruction of the elements by static electricity, be careful to maintain an optimum work environment.

- a. Be sure to ground the body when handling the LCD Modules.
- b. Tools required for assembly, such as soldering irons, must be properly ground.
- c. To reduce the amount of static electricity generated, do not conduct

assembly and other work under dry conditions.

- d. The LCD Module is coated with a film to protect the display surface. Be care when peeling off this protective film since static electricity may be generated.

9.2 Storage precautions

9.2.1 When storing the LCD modules, avoid exposure to direct sunlight or to the light of fluorescent lamps.

9.2.2 The LCD modules should be stored under the storage temperature range. If the LCD modules will be stored for a long time, the recommend condition is:

Temperature : 0°C ~ 40°C

Relatively humidity: ≤80%

9.2.3 The LCD modules should be stored in the room without acid, alkali and harmful gas.

9.3 The LCD modules should be no falling and violent shocking during transportation, and also should avoid excessive press, water, damp and sunshine.