



EVERBOUQUET INTERNATIONAL CO., LTD.

WE CATCH THE
BEST TECH. FOREVER

AVAILABLE FROM MIDAS COMPONENTS LTD

PART NO. : MG24065G SERIES

FOR MESSRS. : _____

CONTENTS

<i>NO.</i>	<i>ITEM</i>	<i>PAGE</i>
1.	COVER	1
2.	RECORD OF REVERSION	2
3.	GENERAL SPECIFICATION	3
4.	MECHANICAL DATA	4
5.	ABSOLUTE MAXIMUM RATINGS	5
6.	ELECTRICAL CHARACTERISTICS	6
7.	OPTICAL CHARACTERISTICS	7
8.	OUTLINE DIMENSION	8~9
9.	BLOCK DIAGRAM	10
10.	POWER SUPPLY FOR LCM	11

ACCEPTED BY: _____

PROPOSED BY : _____



RECORD OF REVISION

DATE	PAGE	SUMMARY
2003/8/12	P8	ADD THE 21 TH & 22 TH MOUNTING HOLES OF I/O
	P9	ADD THE 21 TH & 22 TH PIN DEFINITION OF INTERFACE
2003/9/18	P4	MODIFY THE MECHANICAL DATA: (3)EFFECTIVE AREA: 132.6W*39.0H→134.0W*40.0H

3. General specifications

3.1 General specifications

PLEASE REFER TO:

“CUSTOMER ACCEPTANCE STANDARD SPECIFICATIONS (MS-10-6963C)”.

3.2 This individual specification is prior to general specifications

3.3 NUMBERING SYSTEM

MG24065G -

S	G	L	W	U
---	---	---	---	---

(1) (2) (3) (4) (5)

(1).LCD TYPE :

“S” : STN TYPE

“F” : FSTN TYPE

(2).LCD COLOR :

“Y” : YELLOW-GREEN

“G” : GRAY

“B” : BLUE(STN/ NEGATIVE) / BLACK(FSTN/ NEGATIVE)

“W” : WHITE(FSTN/ POSITIVE)

(3).BACKLIGHT TYPE :

“E” : EL BACKLIGHT

“L” : LED BACKLIGHT

“R” : REFLECTIVE

(4).BACKLIGHT COLOR :

LED TYPE :

“nil” : YELLOW-GREEN

“A” : AMBER

“B” : BLUE

“G” : GREEN

“O” : ORANGE

“R” : RED

“W” : WHITE

(5).VIEWING ANGLE :

“nil” : 6 O’CLOCK

“U” : 12 O’CLOCK

4. Mechanical data

(1) NUMBER OF DOT----- 240 W* 64 H DOTS

(2) MODULE SIZE ----- 180.0 W * 65.0 H * C T (Max) mm

(The value of “C” refer to Outline Dimension P8/11)

(3) EFFECTIVE AREA ----- 134.0 W * 40.0 H mm 

(4) ACTIVE AREA ----- 127.16 W * 33.88 H mm

(5) DOT SIZE----- 0.49 W * 0.49 H mm

(6) DOT PITCH ----- 0.53 W * 0.53 H mm

5. Absolute maximum ratings

5.1 Electrical absolute maximum ratings

<i>I T E M</i>	<i>SYMBOL</i>	<i>MIN.</i>	<i>MAX.</i>	<i>UNIT</i>	<i>COMMENT</i>
POWER SUPPLY FOR LOGIC	V _{DD} -V _{SS}	0	6.0	V	-----
INPUT VOLTAGE	V _I	V _{SS}	V _{DD}	V	-----
STATIC ELECTRICITY	-----	-----	100	V	NOTE (1)
POWER SUPPLY FOR EL BACKLIGHT	V _{EL}	-----	AC200	V _{rms}	f _{EL} =1.0KHz 60 SEC.MAX
	f _{EL}	-----	2.0	KHz	AC115 V _{rms} 60 SEC.MAX
POWER SUPPLY FOR LED	V _{LED}	-----	6.0	V	-----

NOTE (1): ELECTRO-STATIC DISCHARGE RESISTANCE IS TESTED BY CHARGING A 200PF CAPACITOR AND DISCHARGING IT BY CONTACT WITH A INTERFACE CONNECTOR PIN.

5.2 Environmental absolute maximum ratings

<i>I T E M</i>	<i>OPERATING</i>		<i>STORAGE</i>		<i>COMMENT</i>
	<i>MIN.</i>	<i>MAX.</i>	<i>MIN.</i>	<i>MAX.</i>	
AMBIENT TEMPERATURE	-20	70	-20	70	-----
HUMIDITY	NOTE (2)		NOTE (2)		NO CONDENSATION
VIBRATION NOTE (3)	-----	0.5G	-----	2G	10 300HZ XYZ DIRECTIONS 1 Hr EACH
SHOCK NOTE (3)	-----	3G	-----	50G	10 msec XYZ DIRECTIONS 1 TIME EACH
CORROSIVE GAS	NOT ACCEPTABLE		NOT ACCEPTABLE		-----

NOTE (2): Ta 50 : 90% RH MAX.

Ta > 50 : ABSOLUTE HUMIDITY MUST BE LOWER THAN THE HUMIDITY OF 90% RH AT 50 . (80%RH AT 60)

NOTE (3): 1G = 9.8 m/s²

6. Electrical characteristics

Ta = 25

VDD = 5.0 ± 0.25 V

ITEM	SYMBOL	CONDITION	MIN.	TYP.	MAX.	UNIT	
POWER SUPPLY VOLTAGE FOR CIRCUIT	V _{DD} -V _{SS}	-----	4.75	5.0	5.25	V	
INPUT VOLTAGE NOTE (1)	V _{IH}	H LEVEL	2.0	-----	V _{DD}	V	
	V _{IL}	L LEVEL	0	-----	0.8	V	
OUTPUT VOLTAGE NOTE (2)	V _{OH}	I _{OH} = -0.3 mA	2.4	-----	-----	V	
	V _{OL}	I _{OH} = 3.0 mA	-----	-----	0.4	V	
POWER SUPPLY CURRENT, NOTE (3)	I _{DD}	V _{DD} -V _{SS} = 5.0 V	-----	20.0	30.0	mA	
RECOMMENDED LCD DRIVING VOLTAGE, NOTE(4)	V _{DD} -V _O	STN/ FSTN DUTY =1/64 =10° NOTE(5)	Ta=-20°C	-----	13.1	-----	V
			Ta= 0°C	-----	12.9	-----	V
			Ta= 25°C	-----	12.7	-----	V
			Ta= 50°C	-----	12.5	-----	V
			Ta= 70°C	-----	12.4	-----	V
POWER SUPPLY CURRENT FOR EL BACKLIGHT	I _{EL}	V _{EL} = 115V _{rms} f _{EL} = 400Hz	-----	8.0	-----	mArms	
POWER SUPPLY CURRENT FOR LED	I _{LED}	-----	-----	NOTE(6)	NOTE(6)	mA	

NOTE (1): APPLIED TO TERMINALS DBO ~ DB7,WR,RD,CS,C/D,RES.FS

(2): APPLIED TP TERMINALS DBO ~ DB7

(3): THE DISPLAY PATTERN IS ALL "ON", OR ALL "OFF"

(4): RECOMMENDED LCD DRIVING VOLTAGE MAY FLUCTUATE ABOUT ±0.5V BY EACH MODULE.

(5): = 0° : VIEWING ANGLE AT 6 O'CLOCK

= 180° : VIEWING ANGLE AT 12 O'CLOCK

(6): LED CURRENT OF DEFFERENT LED TYPE

TYPE	V _{LED}	I _{LED} TYP. / MAX.	LED TYPE
A	5.0V	450mA / 700mA	YELLOW-GREEN ,ORANGE (ARRAY LED)
B	4.0V	75mA / 100mA	WHITE (EDGE LED)

(A)

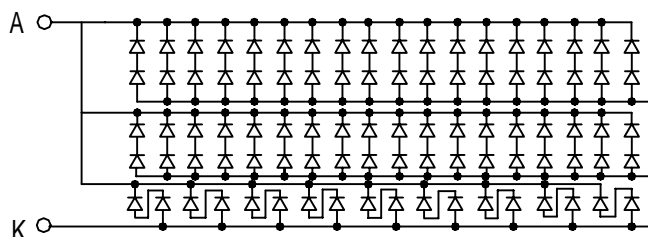

(B)

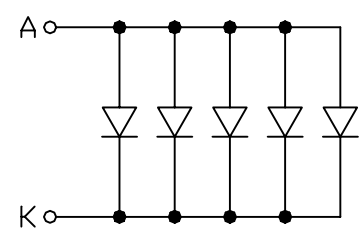

7. Optical characteristics

STN TYPE LCD

Ta = 25

V_{DD}-V_O =12.7V

<i>I T E M</i>	<i>SYMBOL</i>	<i>CONDITION</i>	<i>MIN.</i>	<i>TYP.</i>	<i>MAX.</i>	<i>UNIT</i>	<i>NOTE</i>
VIEWING ANGLE	2- 1	K = 2.0 NOTE(1)	30	40	----	deg.	NOTE(2)
CONTRAST RATIO	K	= 10° NOTE(1)	3.0	4.0	----	----	NOTE(2)
RESPONSE TIME	tr (rise)	= 10° NOTE(1)	----	200	350	ms	NOTE(2)
	tf (fall)	= 10° NOTE(1)	----	300	400	ms	NOTE(2)

FSTN TYPE LCD

Ta = 25

V_{DD}-V_O =12.7V

<i>I T E M</i>	<i>SYMBOL</i>	<i>CONDITION</i>	<i>MIN.</i>	<i>TYP.</i>	<i>MAX.</i>	<i>UNIT</i>	<i>NOTE</i>
VIEWING ANGLE	2- 1	K = 2.0 NOTE(1)	30	40	----	deg.	NOTE(2)
CONTRAST RATIO	K	= 10° NOTE(1)	4.0	5.0	----	----	NOTE(2)
RESPONSE TIME	tr (rise)	= 10° NOTE(1)	----	200	350	ms	NOTE(2)
	tf (fall)	= 10° NOTE(1)	----	300	400	ms	NOTE(2)

Brightness for backlight

<i>SYMBOL</i>	<i>CONDITION</i>	<i>MIN.</i>	<i>TYP.</i>	<i>MAX.</i>	<i>UNIT</i>	<i>LED TYPE</i>	<i>NOTE</i>
B	= 0° = 0°	4.0	----	----	cd/m ²	EL BACKLIGHT	NOTE(2)
		5.0	----	----		YELLOW-GREEN, ORANGE	
		5.0	----	----		WHITE	NOTE(3)

NOTE (1): = 0° WHEN VIEWING ANGLE AT 6 O'CLOCK
= 180° WHEN VIEWING ANGLE AT 12 O'CLOCK

(2): SEE CUSTOMER ACCEPTANCE STANDARD SPECIFICATION FOR DEFINITION OF OPTICAL CHARACTERISTICS.

(3): UNDER NORMAL TEMPERATURE AND HUMIDITY IN A DARK ROOM.

8.1 Interface pin connection

<i>PIN NO.</i>	<i>SYMBOL</i>	<i>FUNCTION</i>
1	FGND	FRAME GROUND
2	V _{SS}	POWER SUPPLY (GND)
3	V _{DD}	POWER SUPPLY (+5V)
4	V _O	OPERATING VOLTAGE FOR LCD DRIVING
5	\overline{WR}	L: DATA WRITE (LCD MODULE MPU)
6	\overline{RD}	L: DATA READ (LCD MODULE MPU)
7	\overline{CS}	L: CHIP ENABLE
8	C/ \overline{D}	\overline{WR} ="L",C/ \overline{D} ="H": COMMAND WRITE C/ \overline{D} = "L": DATA WRITE \overline{RD} ="L",C / \overline{D} ="H" :STATUS READ C/ \overline{D} = "L" : DATA READ
9	V _{EE}	POWER SUPPLY FOR LCD DRIVING OUTPUT
10	\overline{RES}	L: RESET
11	DB0	DATA INPUT/OUTPUT (LSB)
12	DB1	DATA INPUT/OUTPUT
13	DB2	DATA INPUT/OUTPUT
14	DB3	DATA INPUT/OUTPUT
15	DB4	DATA INPUT/OUTPUT
16	DB5	DATA INPUT/OUTPUT
17	DB6	DATA INPUT/OUTPUT
18	DB7	DATA INPUT/OUTPUT (MSB)
19	FS	TERMINALS FOR SELECTION OF COLUMNS H: 6 * 8 FONT L: 8 * 8 FONT
20	N.C	NO CONNECTION
21	N.C	NO CONNECTION
22	N.C	NO CONNECTION
-----	A	POWER SUPPLY FOR LED BACKLIGHT
-----	K	POWER SUPPLY FOR LED BACKLIGHT

①

9. Block diagram

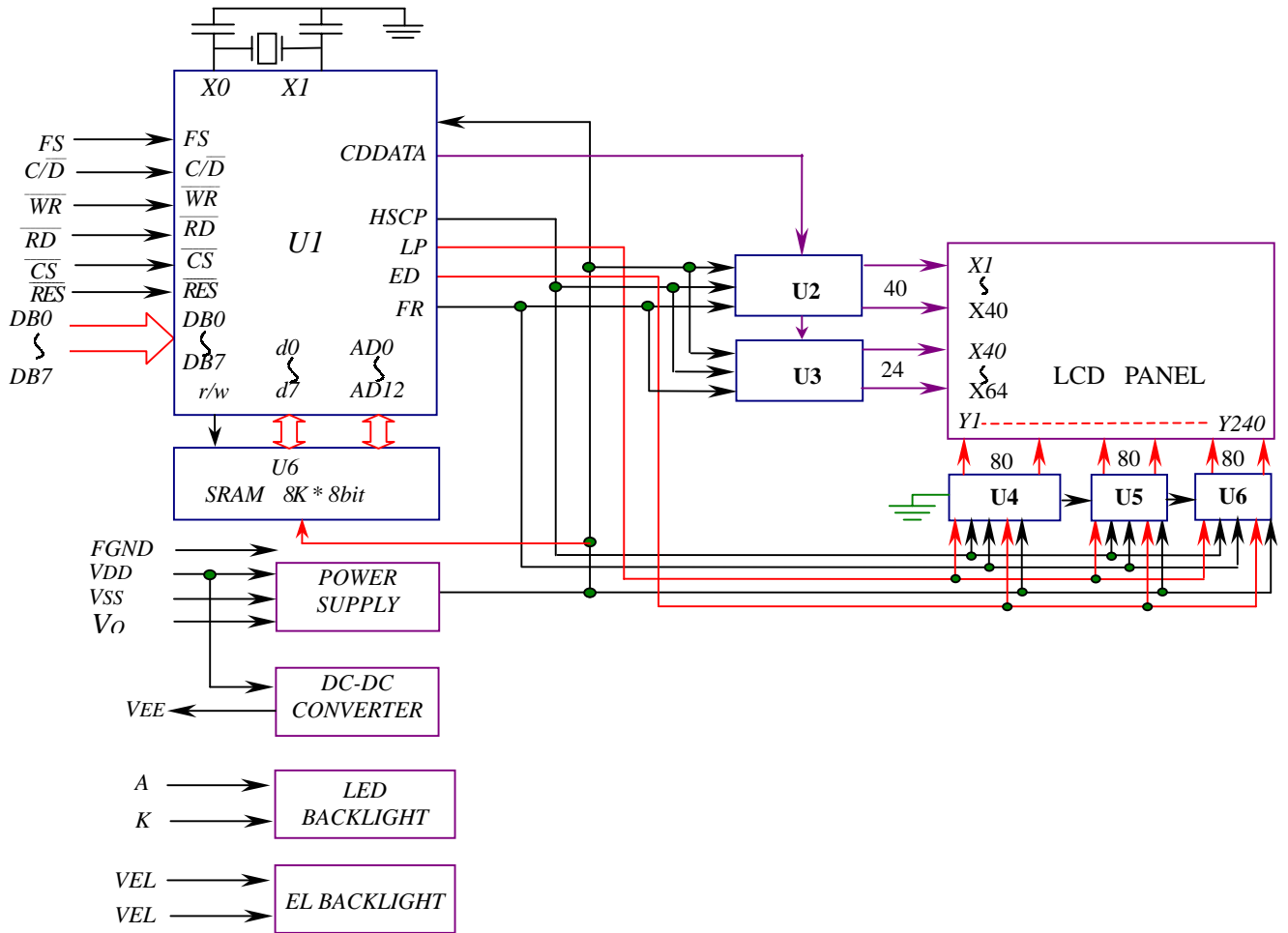

10. Power supply for LCM

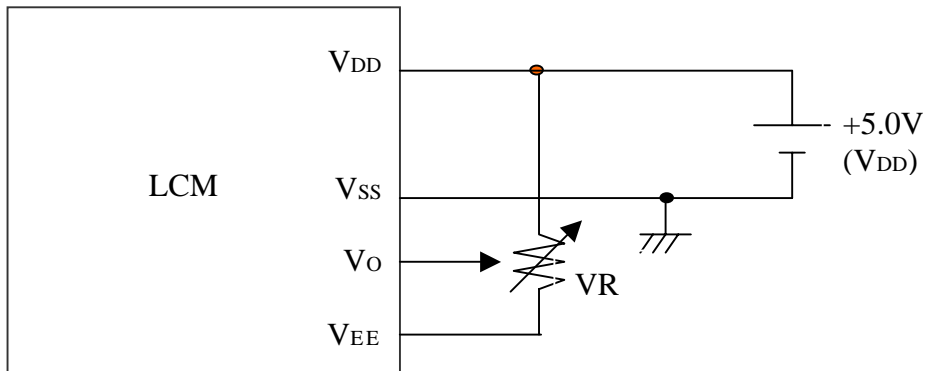

$V_{DD}-V_o$: LCD DRIVING VOLTAGE

VR: 200K

10.1 Power supply for backlight

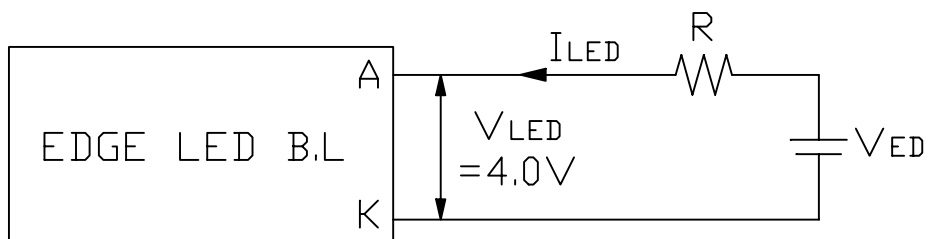
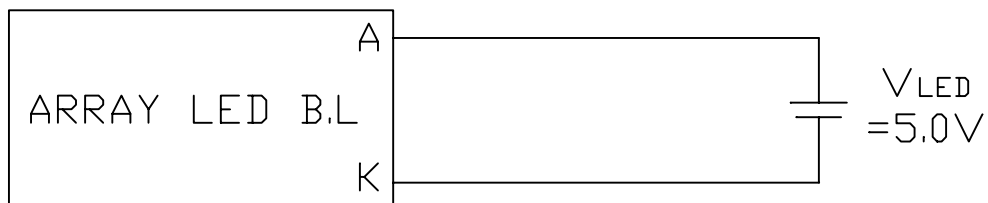
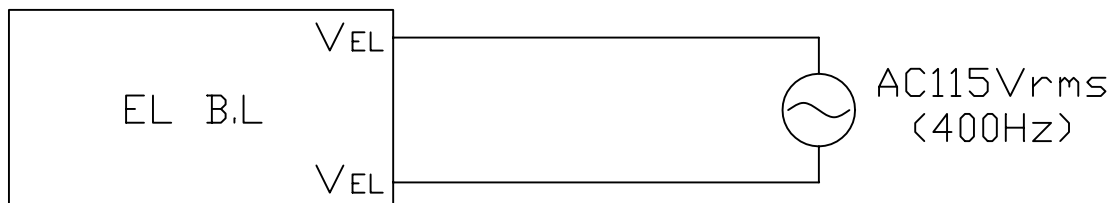

$$R = (V_{ED} - V_{LED}) / I_{LED}, I_{LED} \leq 100.0 \text{ mA (max)}$$