



# GPS Receiver A2035-H

A Description of Maestro's  
GPS Antenna Receiver Module A2035-H

## User's Manual

Version 1.3

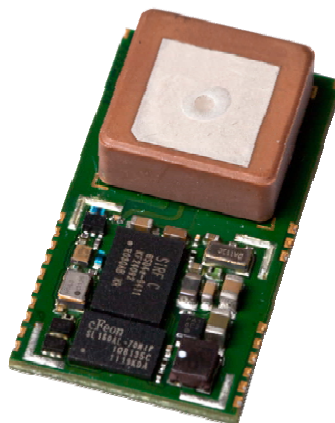

## Revision History

Rev.	Date	Description
0.1	07-05-11	First release
0.2	09-15-11	Updated Table 5: A2035-H electrical characteristics
1.0	11-11-11	Updated photo
1.1	03-01-12	Add Firmware Updates information
1.2	05-24-12	link to 1PPS application note and 1PPS timing accuracy remarks added
1.3	07-25-12	Add 5Hz Navigation Update Rate
	mm-dd-yy	

	Name	Date	Signature
Written by	Happy wen	07-25-12	H W
Checked by	Sam Law, Matthieu	07-25-12	S L,M
Approval by	Frank Tang, Calvin Yau	07-25-12	F T,C Y

## **Disclaimer**

THIS DOCUMENT CONTAINS PROPRIETARY INFORMATION OF MAESTRO WIRELESS SOLUTIONS LIMITED. IT MAY NOT BE COPIED OR TRANSMITTED BY ANY MEANS, PASSED TO OTHERS, OR STORED IN ANY RETRIEVAL SYSTEM OR MEDIA, WITHOUT PRIOR CONSENT OF MAESTRO OR ITS AUTHORIZED AGENTS.

THE INFORMATION IN THIS DOCUMENT IS, TO THE BEST OF OUR KNOWLEDGE, ENTIRELY CORRECT. HOWEVER, MAESTRO CAN NEITHER ACCEPT LIABILITY FOR ANY INACCURACIES, OR THE CONSEQUENCES THEREOF, NOR FOR ANY LIABILITY ARISING FROM THE USE OR APPLICATION OF ANY CIRCUIT, PRODUCT, OR EXAMPLE SHOWN IN THE DOCUMENT.

THE PRODUCT (HARD- AND SOFTWARE) DESCRIBED IN THIS DOCUMENTATION IS NOT AUTHORIZED FOR USE IN LIFE SUPPORT DEVICES OR SYSTEMS WITHOUT THE EXPRESS WRITTEN APPROVAL OF MAESTRO.

THIS DOCUMENT MAY PROVIDE LINKS TO OTHER WORLD WIDE WEB SITES OR RESOURCES. BECAUSE MAESTRO HAS NO CONTROL OVER SUCH SITES AND RESOURCES, MAESTRO SHALL NOT BE RESPONSIBLE FOR THE AVAILABILITY OF SUCH EXTERNAL SITES OR RESOURCES, AND DOES NOT ENDORSE AND IS NOT RESPONSIBLE OR LIABLE FOR ANY CONTENT, ADVERTISING, PRODUCTS, OR OTHER MATERIALS ON OR AVAILABLE FROM SUCH SITES OR RESOURCES. MAESTRO SHALL NOT BE RESPONSIBLE OR LIABLE, DIRECTLY OR INDIRECTLY, FOR ANY DAMAGE OR LOSS CAUSED OR ALLEGED TO BE CAUSED BY OR IN CONNECTION WITH USE OF OR RELIANCE ON ANY SUCH CONTENT, GOODS OR SERVICES AVAILABLE ON OR THROUGH ANY SUCH SITE OR RESOURCE.

MAESTRO RESERVES THE RIGHT TO CHANGE, MODIFY, OR IMPROVE THIS DOCUMENT OR THE PRODUCT DESCRIBED HEREIN, AS SEEN FIT BY MAESTRO WITHOUT FURTHER NOTICE.

## Table of Contents

<b>1 Introduction</b> .....	<b>6</b>
1.1 Feature Overview .....	6
1.2 Characteristics Overview .....	6
1.3 RoHS and Lead-Free Information .....	7
1.4 Label .....	7
1.5 Characteristics .....	9
1.5.1 GPS Characteristics .....	9
1.5.2 Mechanical Characteristics .....	9
1.6 Handling Precautions .....	9
<b>2 Ordering Information</b> .....	<b>10</b>
2.1 GPS Receiver A2035-H .....	10
2.2 Packing .....	10
2.3 Additional Equipment .....	13
<b>3 Quick Start</b> .....	<b>14</b>
3.1 Minimum Configuration .....	14
3.2 Antenna .....	16
3.3 Serial Port Settings .....	16
3.4 Improved TTFF .....	16
3.5 Firmware Updates(Flash-based module only) .....	16
<b>4 Mechanical Outline</b> .....	<b>17</b>
4.1 Details Component Side A2035-H .....	17
4.2 Details Solder Side A2035-H .....	18
<b>5 Pin-out Information</b> .....	<b>19</b>
5.1 Layout A2035-H .....	19
5.2 Description A2035-H Signals .....	20
<b>6 Electrical Characteristics</b> .....	<b>21</b>
6.1 Operating Conditions .....	21
6.2 Absolute Maximum Ratings .....	21
6.3 DC Electrical Characteristics .....	22
<b>7 Mounting</b> .....	<b>23</b>
7.1 Proposed Footprint for Soldering .....	23
7.2 Recommended Profile for Reflow Soldering .....	23
<b>8 Quality and Reliability</b> .....	<b>25</b>
8.1 Environmental Conditions .....	25
8.2 Product Qualification .....	25
8.3 Production Test .....	25
<b>9 Applications and Hints</b> .....	<b>26</b>
9.1 Initial Module Start .....	26
9.2 Proper Shutdown and Power-On-Reset (POR) .....	26

9.3 SiRFaware™ Support .....	26
9.4 Push-to-Fix Mode .....	26
9.5 Hibernate Mode.....	27
9.6 Extended Ephemeris.....	27
9.7 TM_GPIO5 pin (1 pulse per second pin).....	27
9.8 5 Hz Navigation Update Rate.....	28
<b>10 Evaluation Kit EVA2035-H .....</b>	<b>29</b>
<b>11 Related Information .....</b>	<b>30</b>
11.1 Contact.....	30
11.2 Related Documents.....	30
11.3 Related Tools .....	30
<b>12 List of Figures .....</b>	<b>31</b>
<b>13 List of Tables .....</b>	<b>32</b>

## 1 Introduction

Maestro's GPS antenna receiver module A2035-H is a highly integrated GPS antenna receiver module based on the technology of the GPS receiver module A2100-A and a ceramic GPS patch antenna. The module is capable of receiving signals from up to 48 GPS satellites and transferring them into position and timing information that can be read over a serial port. Small size and high-end GPS functionality are combined at low power consumption.

**NOTE:** Care must be taken to implement an orderly shut-down sequence along with supplying power for a certain period of time after initiating the shut-down sequence. Abrupt removal or drop of power while the module is running has risks ranging from minor impact on TTFF to fatal, permanent corruption of flash memory code area (Please refer to "Power ON/OFF Sequences and Power-On-Reset (POR) on A2100-AB Application Notes")!

### 1.1 Feature Overview

The A2035-H is based on the well-established A1035-H outline and offer new, outstanding features.

- Fast, responsive location experience
  - High-sensitive navigation engine with tracking down to -163dBm
  - 48 track verification channels
  - SBAS (WAAS, EGNOS, MSAS, GAGAN)
- Breakthrough micro power technology
  - Requires only 50 – 500µA to maintain hot start capability
- Active jammer remover
  - Removes in-band jammers up to 80dB/Hz
  - Tracks up to eight CW (continuous wave) jammers

### 1.2 Characteristics Overview

The module's most important characteristics are:

- Operable at 3.3V / 29mA (TBC) @ 1fix per second
- UART interface at CMOS level
- Small form factor of 30.48 x 16.51 mm<sup>2</sup> (1.2" x 0.65")
- Supported temperature range: -40°C to +85°C
- Single-sided SMT component, for reflow soldering
- RoHS compliant, lead-free
- Tape & reel packaging
- On-module patch antenna

The antenna receiver module is available as an off-the-shelf component, 100% tested and shipped in tape-and-reel packaging.

### 1.3 RoHS and Lead-Free Information

Maestro's products marked with the lead-free symbol either on the module or the packaging comply with the "Directive 2002/95/EC of the European Parliament and the Council on the Restriction of Use of certain Hazardous Substances in Electrical and Electronic Equipment" (RoHS).



All Maestro GPS receiver modules, GPS antenna receiver module and telematics units are RoHS compliant.

### 1.4 Label

The A2035-H label (size: 9.5 x 9.5 mm<sup>2</sup>) contains the following information:



Figure 1: A2035-H label

The label is placed on the shield of the module. The data matrix code holds the product type, software version, software release, hardware release, factory code, year & week of assembly and a 6-digit serial number.

Representing	Factory Code	Product Number	Software Version	Software Release	Hardware Release	Assembly Year/Week	Serial Number
Number of digits (25)	XX	XXXXXXXX	XXX	XX	XX	XXXX	XXXXXX
	2	6	3	2	2	4	6
Example	GS	A2035H	410	01	01	1127	000005
Meaning	Given	Given	Given	Given	Given	Year=11 Week=27	Increment from 000001 up to 999999

Example: GSA2035H41001011127000005



## 1.5 Characteristics

The module is characterized by the following parameters.

### 1.5.1 GPS Characteristics

Channels		48, parallel tracking
Correlators		~400,000
Frequency		L1 (= 1,575 MHz)
Tracking Sensitivity On-module antenna		-163 dBm
Horizontal Position Accuracy	Stand alone	< 2.5 m CEP (SA off)
Time To First Fix – TFFF (theoretical minimum values; values in real world may differ)	Obscuration recovery <sup>(1)</sup>	0.1 s
	Hot start <sup>(2)</sup>	< 1 s
	Warm <sup>(3)</sup>	< 32 s
	Cold <sup>(4)</sup>	< 35 s

Table 1: A2035-H GPS characteristics

- (1) The calibrated clock of the receiver has not stopped, thus it knows precise time (to the  $\mu$ s level).
- (2) The receiver has estimates of time/date/position and valid almanac and ephemeris data.
- (3) The receiver has estimates of time/date/position and recent almanac.
- (4) The receiver has no estimate of time/date/position, and no recent almanac.

Note: Performance (sensitivity and TFFF) might slightly decrease below  $-30^{\circ}\text{C}$ .

### 1.5.2 Mechanical Characteristics

A2035-H Mechanical dimensions	Length	30.48 $\pm$ 0.20 mm, 1.2 $\pm$ 0.008"
	Width	16.51 $\pm$ 0.20 mm, 0.65 $\pm$ 0.008"
	Height	5.10 mm, 0.201"(Max)
A2035-H Weight		4.0 g, 0.14 oz

Table 2: A2035-H dimensions and weight

## 1.6 Handling Precautions

The GPS receiver module A2035-H is sensitive to electrostatic discharge (ESD). Please handle with appropriate care.

## 2 Ordering Information

### 2.1 GPS Receiver A2035-H

The order number is built as follows:

- **A2035-Hxxx**

A2035-H for the A2035-H module. The “xxx” reflects the current firmware version. If no firmware version is noted in an order, the latest version will be provided.

### 2.2 Packing

The A2035-H GPS modules come in a tape and reel package suitable for pick and place machines.

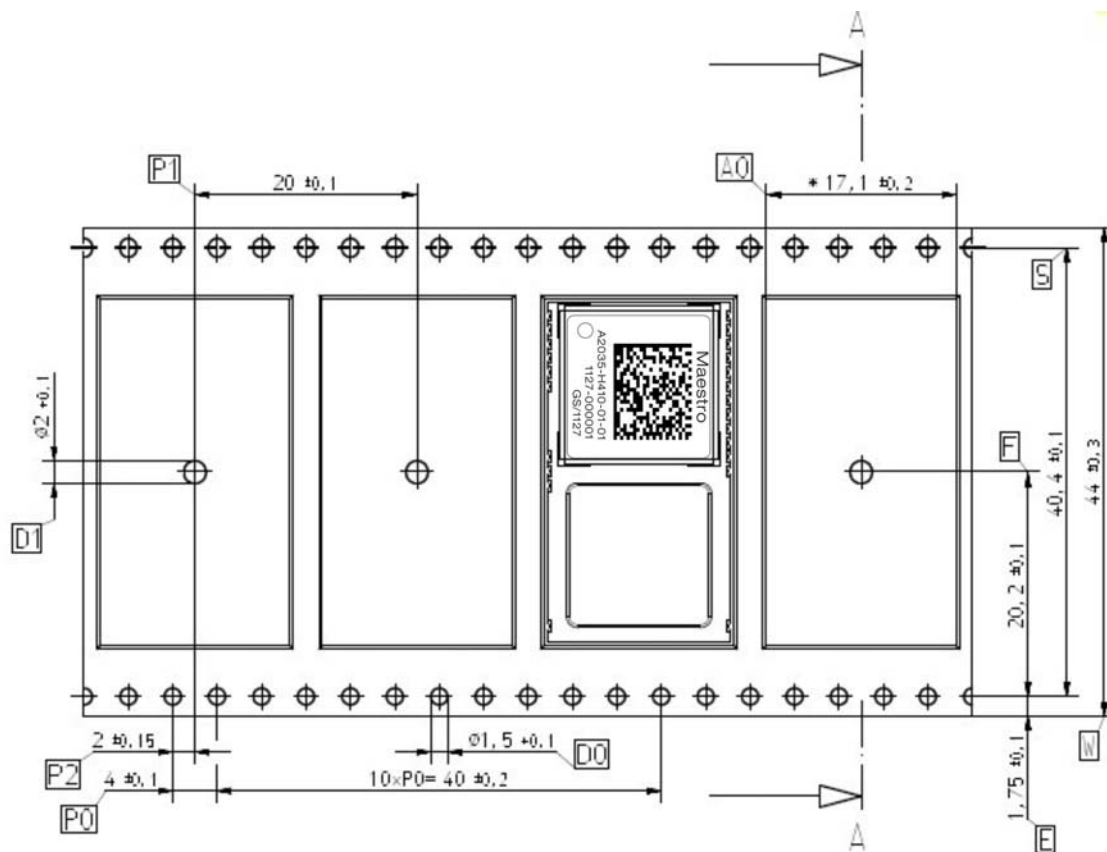

Figure 2: A2035-H tape specifications (1)

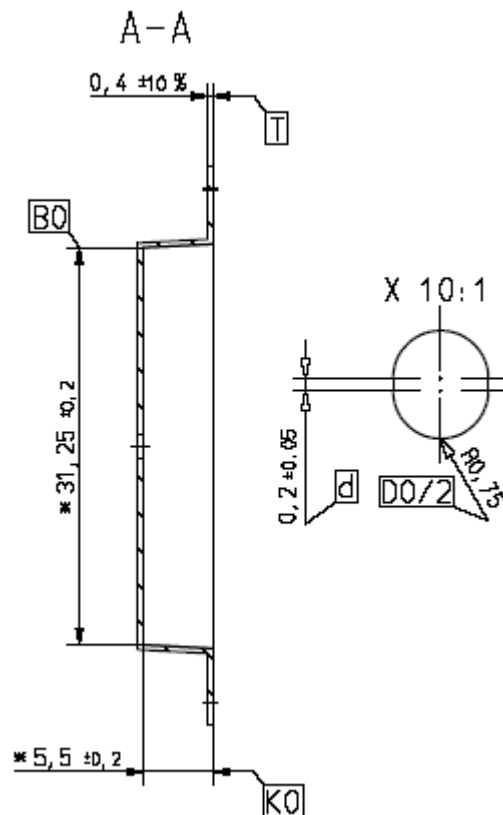

Figure 3: A2035-H tape specifications (2)

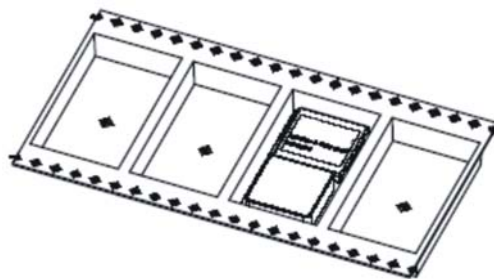

Figure 4: A2035-H tape specifications (3)

One complete reel holds 700 A2035-H modules.

There are 2 kinds of packaging for shipment:

A: One box holds 1 reel

Reel diameter: 38 cm

Outer Box dimensions: 38.8 (W) x 38.8 (L) x 5.7 (H) cm

Gross weight: 5.06 Kg

Net weight: 4.13 Kg

- B: One box holds 2 reels
- Reel diameter: 38 cm
- Outer box dimensions: 38 (W) x 38 (L) x 12.3 (H) cm
- Gross weight: 10.03 Kg
- Net weight: 8.26 Kg

## 2.3 Additional Equipment

EVA2035-H	Evaluation Kit (including one module A2035-H)
-----------	---

Table 3: Additional equipment

A detailed description of the EVA2035-H Evaluation Kit can be found in the appropriate manual.

### 3 Quick Start

In order to allow an easy and quick start with the A2035-H module, this chapter provides a short overview on the important steps to be taken to receive NMEA messages with position information on a serial port (UART).

**NOTE 1:** The A2035-H needs an external pull-up resistor to be configured for UART operation. Please consider the pull-up resistor in your design or pull the GPIO up right after reset by other means.

**NOTE 2:** The ON\_OFF input of the A2035-H needs to be connected to output of a microprocessor. For a wake-up, including the initial one after power on, a LOW-HIGH transmission is mandatory.

#### 3.1 Minimum Configuration

The following picture shows the minimum configuration for NMEA or binary outputs received and commands sent via an RS232 interface based on the GPS module A2035-H.

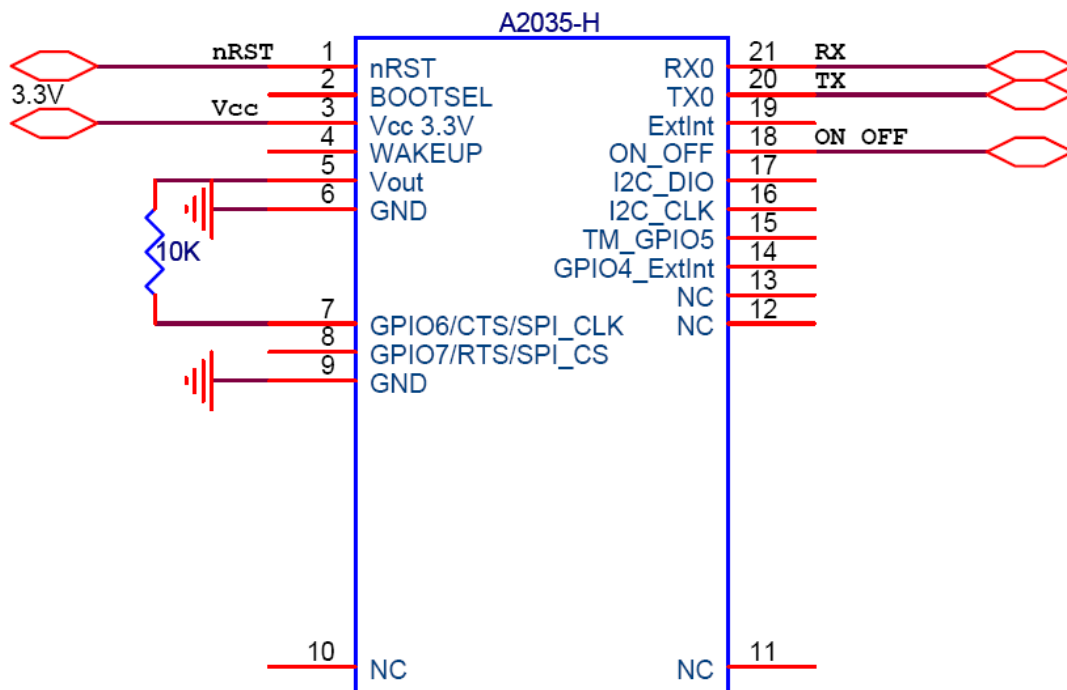

Figure 5: Minimum configuration A2035-H

**NOTE:** It is recommended to supply Vcc continuously! Use SiRFaware™ or other low power modes to reduce power consumption of the module while no position information is required.

**NOTE:** Care must be taken to implement an orderly shut-down sequence along with supplying power for a certain period of time after initiating the shut-down sequence. Abrupt removal or drop of power while the module is running has risks ranging from minor impact on TTFF to fatal corruption of flash memory code area (Please refer to “Power ON/OFF Sequences and Power-On-Reset (POR) on A2100-AB Application Notes”)!

For completeness the following pictures show the use of an RS232 level shifter.

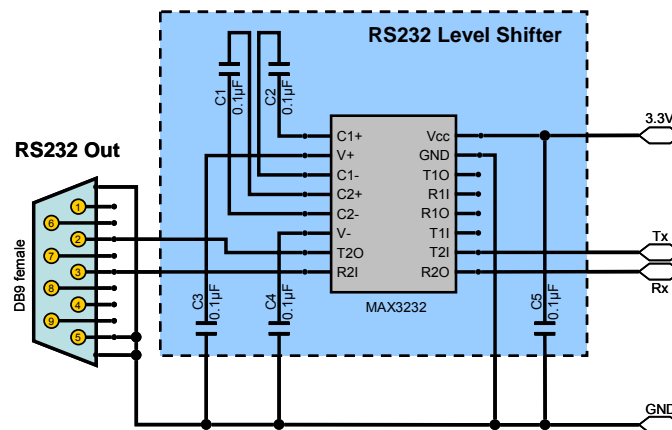

Figure 6: RS232 level shifter for minimum configurations

Remarks:

- Place C1 to C5 (here: 0.1µF) close to MAX3232. For capacity values see datasheet of actual component used.
- Use 3.3V level shifter (MAX3232 or equivalent).

### 3.2 Antenna

The A2035-H through the LNA connected to a ceramic passive GPS patch antenna.

### 3.3 Serial Port Settings

The default configuration within the custom-specific GPS firmware is:

- Serial 0 (NMEA) 4800 baud, 8 data bits, no parity, 1 stop bit, no flow control

### 3.4 Improved TTFF

In order to improve the TTFF (Time To First Fix), it is recommended to keep Vcc supplied at all times. This will allow taking advantage of sophisticated low power mode features of the SiRFstarIV chip set. More details can be found in chapter “Application Notes”.

### 3.5 Firmware Updates(Flash-based module only)

Firmware upgrade function is only valid for Flash-based module. If later firmware changes are considered in a design it is necessary to connect the BOOTSEL pin of the A2035-H. BOOTSEL pin is used to control the mode of operation mentioned on table below:

BOOTSEL	Operating mode
Leave open	Normal operation
Pull up to 1.8V	Boot loader active for firmware upgrade

Table 4: BOOTSEL operating mode

A specific tool (SiRFFlash) is required for firmware upgrade upon request to Maestro. Recommended circuitry on application board was indicated below.

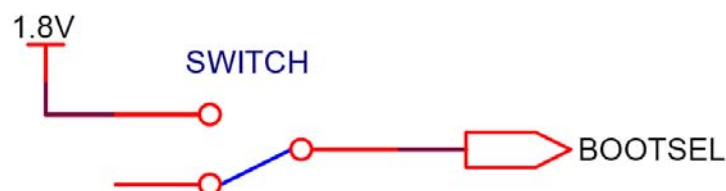
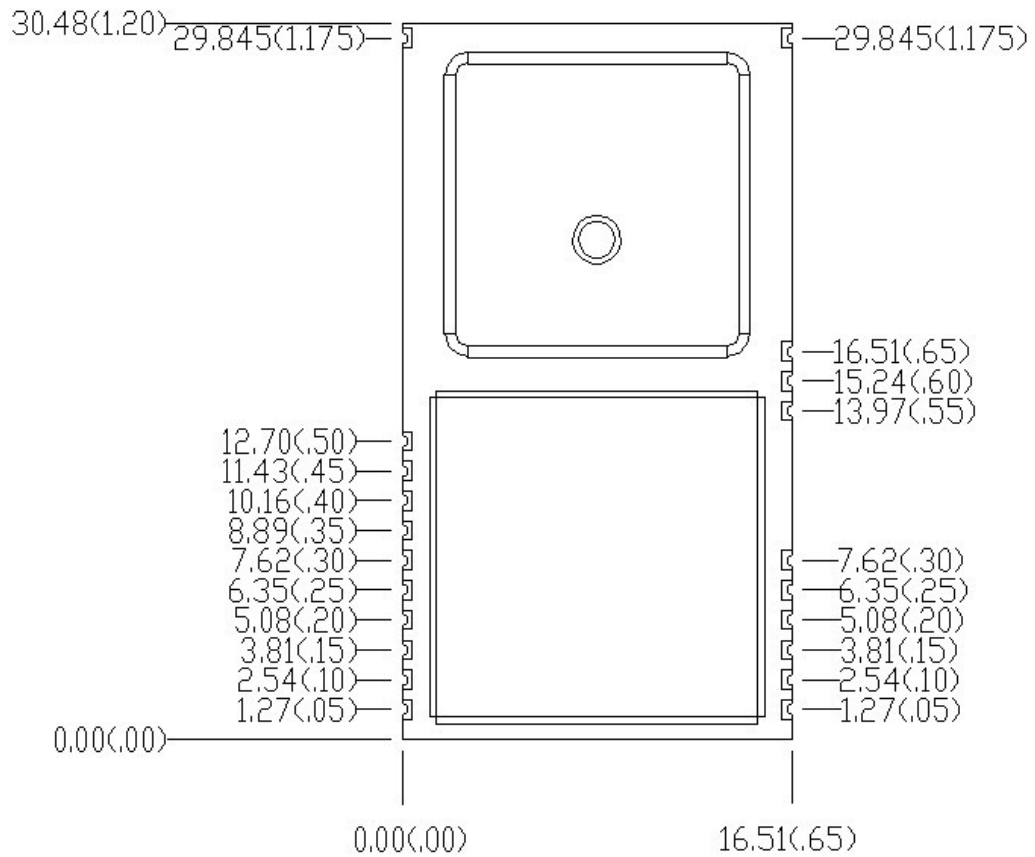

Figure 7: BOOTSEL application



## 4 Mechanical Outline

### 4.1 Details Component Side A2035-H



All dimensions in [mm] / [(inches)]

Figure 8: Mechanical outline component side A2035-H

## 4.2 Details Solder Side A2035-H

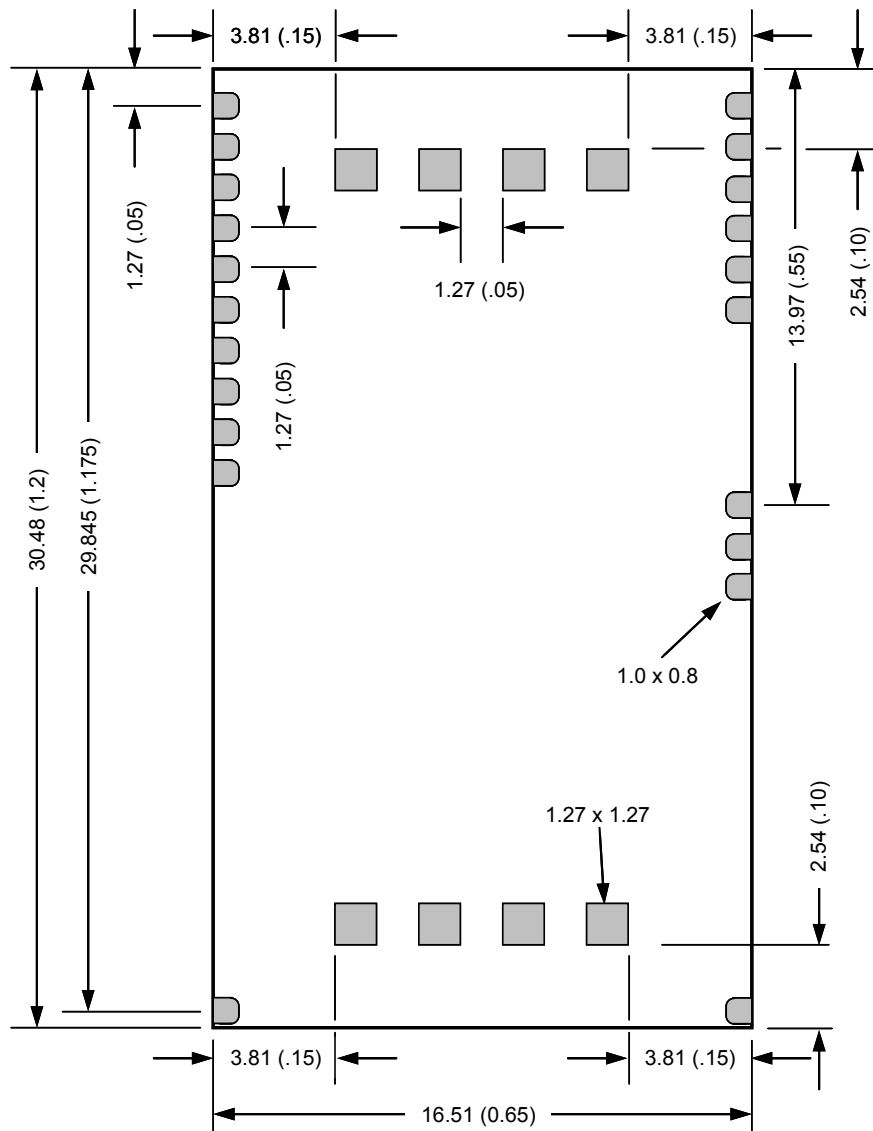

Solder pad size (outer pads): 1.0 x 0.8  
 Solder pad size (inner pads): 1.27 x 1.27  
 All dimensions in [mm] / [(inches)]

Figure 9: Mechanical outline solder side A2035-H

## 5 Pin-out Information

### 5.1 Layout A2035-H

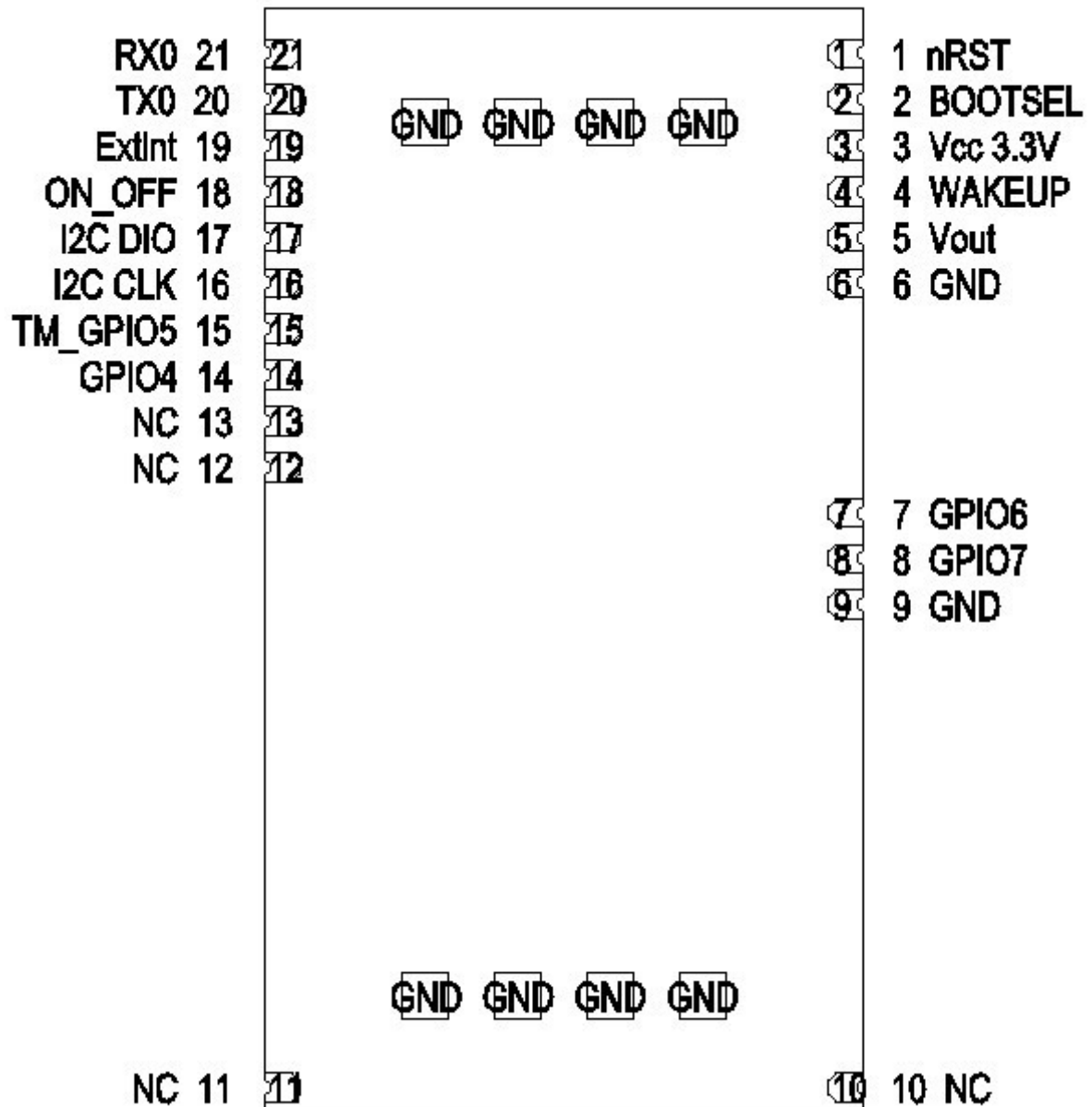

Figure 10: Pin-out information (bottom view) A2035-H

## 5.2 Description A2035-H Signals

Pin	Symbol	Function	Description
1	nRST	Input	Reset input, active low
2	BOOTSEL	Input	Special boot mode – leave open for normal operation; 1.8V for boot loader active
3	Vcc	Power Supply	3.0 – 3.6 V DC
4	WAKEUP	Output	Status of digital section
5	Vout	Voltage Output	Permanent 1.8V voltage output for up to 20mA current max.
6	GND	Power Supply	Ground (power supply)
7	GPIO6 / CTS/ SPI CLK	Input	Configuration pin for communication mode. 10K to 1.8V for UART mode; leave open for SPI mode. SPI clock pin when module works in SPI mode
8	GPIO7 / RTS/ SPI CS	Input	SPI chip select pin when module works in SPI mode
9	GND	Power Supply	Ground (power supply)
10	NC	None	Mechanical fixture only
11	NC	None	Mechanical fixture only
12	NC	None	Leave open
13	NC	None	Leave open
14	ExtInt 2 / GPIO4	Input	External interrupt input pin – reserved for future use, leave open
15	TM_GPIO 5	Output	Time Mark – 1PPS signal
16	I2C CLK	Input	I2C clock input for MEMS interface
17	I2C DIO	Input / Output	I2C I/O for MEMS interface
18	ON_OFF	Input	Connect to push-pull output is mandatory. - Set to LOW by default - Toggle to HIGH and back to LOW > for first start-up after power on > to request a fix in SiRFaware™ or PTF mode > to go into or wake up out of hibernate mode
19	ExtInt / GPIO8	Input	Interrupt input for MEMS interface. (If ExtInt is not going to be used, it is recommended that this pin be tied directly to ground. Otherwise, a 100K pull-down resistor to ground should be connected to the ExtInt pin.)
20	TX0 / SPI DO	Output	Serial output 0. NMEA out if configured for UART; SPI data out pin when module works in SPI mode
21	RX0 / SPI DI	Input	Serial input 0. NMEA in if configured for UART; SPI data in pin when module works in SPI mode

Table 5: Pin description A2035-H

## 6 Electrical Characteristics

### 6.1 Operating Conditions

Pin	Description	Min	Typical	Max
3	Vcc	3.0V	3.3V	3.6V
	Full power mode (Searching) Peak Current (1)		49mA (TBC)	
	Full power mode (Searching) Average Current (2)		41mA	
	Full power mode (Tracking) Average Current (3)		24mA	
	Push-to-Fix Mode		920uA	
	Micro Power Mode ( SiRFaware™)		56uA	
	Hibernate Status		25uA	

Table 6: A2035-H electrical characteristics

- (1) Peak searching current is characterized by millisecond bursts above average searching current
- (2) Average searching current is typically only the first two seconds of TTFF
- (3) Tracking current typically includes tracking and the post searching portion of TTFF

### 6.2 Absolute Maximum Ratings

Symbol	Parameter	Min	Max	Unit
Vcc	Power supply	-0.3	+4.6	V
Vin	Voltage to I/O pin	-0.3	+3.6	V
Iov	Input current on any pin	-10	10	mA
Itdv	Absolute sum of all input currents during overload condition		200	mA
Tst	Storage temperature	-40	85	°C

Table 7: Absolute maximum ratings

Stresses beyond those listed under “Absolute Maximum Ratings” may cause permanent damage to the device. This is a stress rating only. Functional operation of the device at these or any other conditions beyond those indicated in the operational sections of this specification is not implied. Exposure to absolute maximum rating conditions for extended periods may affect device reliability.

### 6.3 DC Electrical Characteristics

Symbol	Parameter	Min	Max	Unit
TX0, WAKEUP	Voh @ 4mA	2.6	Vcc	V
	Vol @ 4mA		0.45	V
RX0	Vih	2.0	Vcc	V
	Vil		0.8	V
nRST	For safe reset		0.2	V
ON_OFF	Vih	1.35	Vcc	V
	Vil	-0.3	0.45	V
BOOTSEL	Vih	1.35	2.2	V

Table 8: DC electrical characteristics

## 7 Mounting

This chapter describes the suggested mounting process for the A2035-H receiver modules. In a RoHS compliant product with a RoHS compliant process it is recommended to use chemical tin as the counter-part to the module's pins. This will guarantee highest resistance against shocks.

### 7.1 Proposed Footprint for Soldering

The following proposal of a footprint for soldering is assuming a stencil thickness of 150µm. ✕ marks the center of the through holes.

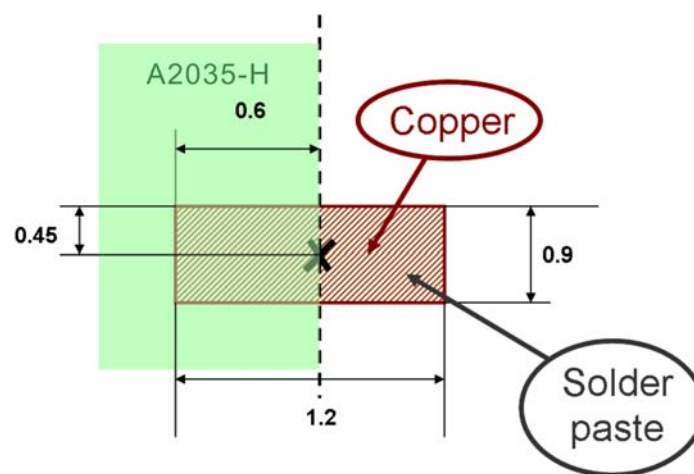

Figure 11: Soldering footprint proposal A2035-H

Please note that copper and solder paste footprint are identical. The final footprint has to be evaluated and qualified by the manufacturer according to the specific processes.

### 7.2 Recommended Profile for Reflow Soldering

Typical values for reflow soldering of the module in convection or IR/convection ovens are as follows (according to IPC/JEDEC J-STD-020D):

Parameter	Value
Peak temperature (RoHS compliant process)	245°C
Average ramp up rate to peak (217°C to Peak)	3°C / second max.
Preheat temperature	min=150°C; max=200°C
Ramp up time from min. to max. preheat temperature	60 ... 120 seconds
Temperature maintained above 217°C	60 ... 150 seconds
Time within 5°C of actual peak temperature	30 seconds
Ramp down rate	6°C / second max.
Time 25°C to peak temperature	8 minutes max.

Table 9: Reflow soldering profile A2035-H

As results of soldering may vary among different soldering systems and types of solder and depend on additional factors like density and types of components on board, the values above should be considered as a starting point for further optimization.



## 8 Quality and Reliability

### 8.1 Environmental Conditions

Operating temperature	-40°C ... +85°C
Operating humidity	Max. 85% r. H., non-condensing, at 85°C
MSL JEDEC (Moisture Sensitivity Level)	3
Storage	6 months in original package

Table 10: Environmental conditions

### 8.2 Product Qualification

Prior to product qualification the GPS receiver is preconditioned according to EIA/JEDEC standard JESD22-A113-B / Level 3.

Basic qualification tests:

- MSL Classification according to J-STD-020C (MSL3 @ 245°C)
- MSL Rework Compatibility according to J-STD-020C
- Temperature Cycling –40°C ... +85°C
- Temperature Humidity Bias 70°C / 85% RH
- Low / High Temperature Operating –40°C / +85°C
- High Temperature Operating Life +85°C
- Vibration Variable Frequency
- Mechanical Shock

Please contact Maestro for detailed information.

### 8.3 Production Test

Each module is electrically tested prior to packing and shipping to ensure state of the art GPS receiver performance and accuracy.

## 9 Applications and Hints

### 9.1 Initial Module Start

After initially applying power to the module, it is necessary to start the internal firmware by toggling the ON\_OFF pin. Toggling is done by pulling the signal to HIGH for about 200ms. This first toggling can be done after a LOW – HIGH transmission was detected at the WAKEUP pin or by simply waiting for 1s after power-up. In case of configuration for UART mode, messages should be transmitted afterwards. If no messages should appear, a new toggling should be applied.

### 9.2 Proper Shutdown and Power-On-Reset (POR)

The A2035-H modules require an orderly shutdown process to properly stop internal operation and complete any writes of critical data to BBRAM or Flash memory data area. Abrupt removal or drop of main power while the system is running has risks ranging from minor impact on TTFF to fatal, permanent corruption of flash memory code area on the module (Please refer to “Power ONOFF Sequences and Power -On-Reset (POR) on A2100-AB Application Notes”).

A controlled and orderly shutdown while the A2035-H is running in full power mode can be initiated by

- A 200ms pulse on the ON\_OFF pin,
- According messages either in NMEA or OSP mode.

The shutdown is completed after maximum 1s. Therefore the module should be supplied with voltage for that time after the shutdown sequence was initiated.

### 9.3 SiRFaware™ Support

SiRFaware™ is a low-power operating mode that seeks to maintain low uncertainty in position, time, and frequency, and to maintain valid current Ephemeris using either data collected from satellites in view or Extended Ephemeris methods.

The SiRFaware™ mode is entered using the One Socket Protocol, an extension of the SiRF Binary Protocol. Please refer to the appropriate manual. In order to request a fix and to exit SiRFaware™ it is necessary to toggle the ON\_OFF pin. Toggling is done by pulling the signal to HIGH for about 200ms.

### 9.4 Push-to-Fix Mode

Push-to-Fix mode is designed for the application that requires infrequent position reporting. The receiver generally stays in a low-power mode, up to 2 hours, but wakes up periodically to refresh position, time, ephemeris data and RTC calibration.

The push-to-fix mode is initialized and entered using the SiRF Binary Protocol. Please refer to the appropriate manual, paying particular attention to the paragraph

titled “Set TricklePower Parameters”. In order to request a fix outside the specified duty cycles, it is necessary to toggle the ON\_OFF pin. Toggling is done by pulling the signal to HIGH for about 200ms.

## 9.5 Hibernate Mode

In order to enter Hibernate Mode it is necessary to send a shutdown command or to toggle to ON\_OFF pin by pulling the signal to HIGH for about 200ms. Starting with firmware version 4.0.1 the according command is supported in NMEA and SiRF Binary mode. After a short delay the module will switch into hibernate mode. The RTC will keep on running and SRAM is backed with the typical current of 20  $\mu$ A drawn from Vcc. To wake the module up again, toggling the ON\_OFF pin is necessary (200ms pulse width).

## 9.6 Extended Ephemeris

The receiver is capable of supporting two versions of using Extended Ephemeris (EE) data. The first one is the version, where the EE data are calculated on a server, are transmitted to device incorporating the receiver, and are then loaded into the receiver. These data can be valid for up to seven days.

The second version is the internal extrapolation of available “natural” Ephemeris data. This is done automatically and no external support is required. The internally calculated EE data are valid for up to 3 days.

The receiver firmware will define which set of EE data to use or will neglect those in case “natural” data are available. Both versions of EE data will help to further lower power consumption in SiRFaware™ mode.

## 9.7 TM\_GPIO5 pin (1 pulse per second pin)

The 1PPS pin is an output pin.

In addition to precise positioning, GPS also allows for accurate timing due to the synchronized atomic clocks in the GPS satellites. While the current date and time is transmitted in NMEA sentences (UTC), an exact and accurate timing signal is provided via the 1PPS pin of the A2035-H GPS receiver.

Under good signal conditions the 1PPS signal comes between 620ns and 710ns after the full GPS system second which is accurately (around 10ns) synchronized to UTC. Therefore the 1 second clock can be derived and maintained within around 90ns under good signal conditions.

Note:

The 1PPS clock accuracy directly depends on the position accuracy!

The GPS signals travel at the speed of light, therefore a position inaccuracy directly translates into 1PPS inaccuracies.

10m position deviation  $\approx$  33ns 1PPS deviation (typically)  
 100m position deviation  $\approx$  333ns 1PPS deviation (typically)

The NMEA messages containing absolute timing information (UTC time) are provided around 300ms after the 1PPS signal typically. This may change with the GPS receiver setup.

The 1PPS signal is provided on a “as is” basis with no accuracy specification. It’s NOT recommended to use 1PPS signal for accurate timing application. The given values are based on a 10 satellite, static GPS simulator scenario.

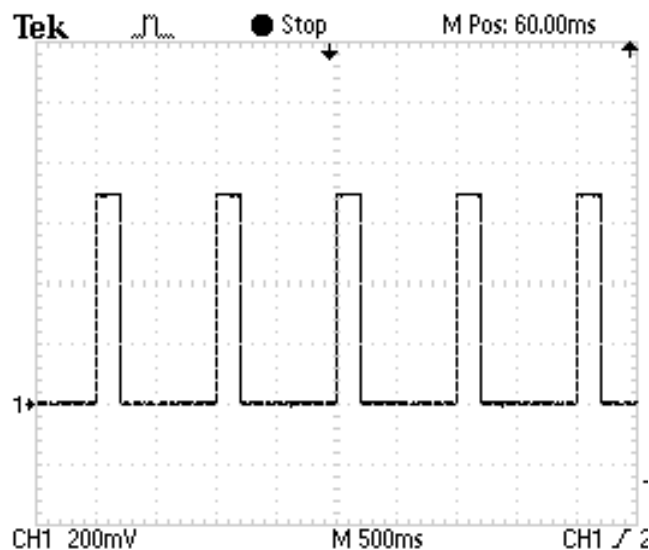

Figure 12: 1PPS waveform (reference)

### 9.8 5 Hz Navigation Update Rate

User can select 1Hz or 5Hz output rate of navigation computation and message, it supports rapid change of direction and improves accuracy on sport-related applications. 1Hz is the default Navigation Update Rate, If the user want to change to 5Hz Navigation Update Rate, Please refer to command below:

Enable 5Hz Navigation Update Rate command

- NMEA command MID103 (\$PSRF103,00,6,00,0\*23)
- OSP command MID136 (A0 A2 00 0E 88 00 00 04 04 00 00 00 00 00 00 00 0F 02 00 A1 B0 B3 )

Disable 5Hz and return to 1Hz Navigation Update Rate, command:

- NMEA command MID103 (\$PSRF103,00,7,00,0\*22)
- OSP command MID136 (A0 A2 00 0E 88 00 00 04 00 00 00 00 00 00 00 00 0F 02 00 9D B0 B3)

## 10 Evaluation Kit EVA2035-H

For demonstration and easy evaluation of GPS performance Maestro offers an evaluation kit (including one GPS A2035-H module). It contains a USB interface with according drivers to connect easily to a PC. The USB interface is an extension of the serial port 0, therefore sending NMEA sentences and accepting commands. At the same time it provides power to the module. Accompanied by an antenna it offers a ready-to-go set.

For the development of new software and applications the Evaluation Kit also provides NMEA messages on CMOS level via a terminal plug.

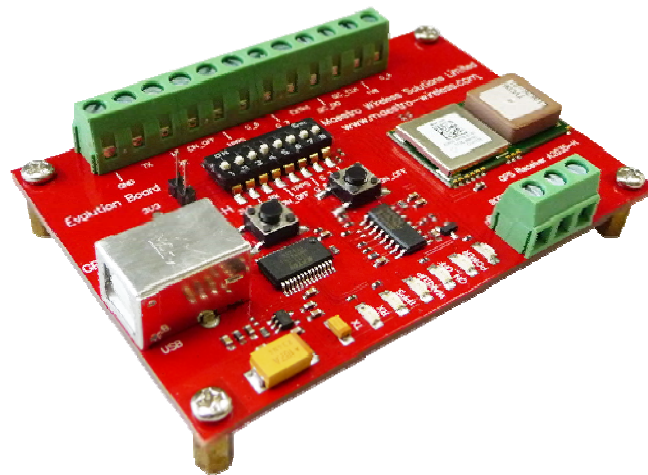

Figure 13: Evaluation kit EVA2035-H

For further information please contact Maestro.

## 11 Related Information

### 11.1 Contact

This manual was created with due diligence. We hope that it will be helpful to the user to get the most out of the GPS module.

Any inputs regarding possible errors or mistakable verbalizations, and comments or proposals for further improvements to this document, made to Maestro, HongKong, are highly appreciated.

#### **Maestro Wireless Solutions Limited**

Add:Unit 3603-09,36/F.,118 Connaught Road West,HK

Main Line: (852) 28690688

Fax: (852)25254701

support-gps@maestro-wireless.com

www.maestro-wireless.com

### 11.2 Related Documents

- Firmware upgrading for GPS Modules (Maestro)
- GPS Evaluation Kit EVA2035-H (Maestro)
- Power ONOFF Sequences and Power-On-Reset (POR) on A2100-AB (Maestro)
- SiRF\_OSP\_Reference\_Manual (SiRF)
- SiRF\_NMEA\_Reference\_Manual (SiRF)

### 11.3 Related Tools

- GPS Cockpit (Maestro)
- SiRFLive (SiRF)
- SiRF Flash (SiRF)

## 12 List of Figures

Figure 1: A2035-H label .....	8
Figure 2: A2035-H tape specifications (1) .....	10
Figure 3: A2035-H tape specifications (2) .....	11
Figure 4: A2035-H tape specifications (3) .....	11
Figure 5: Minimum configuration A2035-H .....	14
Figure 6: RS232 level shifter for minimum configurations .....	15
Figure 7: BOOTSEL application .....	16
Figure 8: Mechanical outline component side A2035-H .....	17
Figure 9: Mechanical outline solder side A2035-H .....	18
Figure 10: Pin-out information (bottom view) A2035-H .....	19
Figure 11: Soldering footprint proposal A2035-H .....	23
Figure 12: 1PPS waveform (reference) .....	28
Figure 13: Evaluation kit EVA2035-H .....	29

## 13 List of Tables

Table 1: A2035-H GPS characteristics.....	9
Table 2: A2035-H dimensions and weight.....	9
Table 3: Additional equipment.....	13
Table 4: BOOTSEL operating mode .....	16
Table 5: Pin description A2035-H .....	20
Table 6: A2035-H electrical characteristics .....	21
Table 7: Absolute maximum ratings .....	21
Table 8: DC electrical characteristics .....	22
Table 9: Reflow soldering profile A2035-H .....	23
Table 10: Environmental conditions .....	25