



Rev. 1.10

Data Sheet

Fastrax IT430

This document describes the electrical connectivity and functionality of the Fastrax IT430 OEM GPS Receiver.

October 12, 2011

Fastrax Ltd

TRADEMARKS

Fastrax is a registered trademark of Fastrax Ltd.

All other trademarks are trademarks or registered trademarks of their respective holders.

COPYRIGHT

© 2011 Fastrax Ltd

DISCLAIMER

This document is compiled and kept up-to-date as conscientiously as possible. Fastrax Ltd cannot, however, guarantee that the data are free of errors, accurate or complete and, therefore, assumes no liability for loss or damage of any kind incurred directly or indirectly through the use of this document. The information in this document is subject to change without notice and describes only generally the product defined in the introduction of this documentation. Fastrax products are not authorized for use in life-support or safety-critical applications. Use in such applications is done at the sole discretion of the customer. Fastrax will not warrant the use of its devices in such applications.

REFERENCES

Ref. #	Publisher; Reference
(1)	CSR; SiRFstar IV Brochure
(2)	CSR; NMEA Reference Manual (CS-129435-MA-2).pdf
(3)	CSR; GSD4e OSP Manual (CS-129291-DC-9).pdf
(4)	National; AN-452.pdf (Microwire Serial Interface)
(5)	NXP; 39340011.pdf (The I2C-Bus Specification)
(6)	Fastrax; Jamming_mitigation.pdf
(7)	Fastrax; Reflow_soldering_profile.pdf
(8)	Fastrax; Self Assistance and CGEE Data Storage to Host.pdf
(9)	Fastrax; SiRF_IV_blocking.pdf
(10)	Fastrax; SiRFIV_low_power_modes.pdf

CHANGE LOG

Rev.	Notes	Date
1.0	Initial documentation	2010-02-18
1.1	Added notes on power up and power removal; relaxed operation temperature range between -40°C and -30°C; increased module height to 1.85 mm, updated table 3 (added I/O type vs. operating mode); added note and spec on ESD sensitivity and avoid ultrasonic exposure	2010-04-19
1.2	Updated power consumption and added notes on internal regulator mode; added note on ESD sensitivity of the antenna input; added out-of-band RF_IN power spec to abs. max	2010-05-11
1.3	Added chapter on reset state. Clarified low power operation modes (added APM; notes on PTF & SiRFAware);	2010-06-04
1.4	Added two module variants, corrected volatile data RAM clearing at reset; added Tape&Reel spec; added chapter on Jammer Remover; clarified operating temperature range down to -40... -30C with relaxed performance	2010-06-28
1.5	Corrected external pull up resistors requirement to DR_I2C bus	2010-06-30
1.6	Changed accelerometer interrupt to EIT signal and EIT2 connection to GND; added operation notes on CGEE usage and ROM patch; updated notes on host SPI and I2C bus; added chapter on ABP; corrected some typos; updated AP430 documents to rev B board; clarified reset operation vs. ROM patch	2010-09-10
1.7	Added note on sensitivity in switcher power mode with passive antenna; changed suggestion of un-used inputs connection to GND (or UART RX & DR_I ² C pull up) and updated reference circuit diagram accordingly; added descriptions on SPI and I ² C host port data transfer; added a chapter on ROM firmware update.	2010-11-16
1.8	Corrected App Board circuit diagram SPI labels; added SPI bus bit order MSB first; added digital I/O ESD spec; corrected module and tape spec in Tape&Reel picture; moved DC & AC Electrical Characteristics to new chapters and tables; omitted Test Points; updated operation due to ROM 1.3 firmware upgrade.	2011-02-10
1.9	Template upgrade; harmonized datasheet with UC430 to match with ROM2.0 firmware operation; added GPIO3 (ECLK) Message_Waiting function in UART handshaking or SPI host port mode; Increased external LNA gain up to +35dB; updated AP430 documents; added Environmental Specification (environmental tests); removed notes on Pedestrian DR; added chapter on 5 Hz navigation; removed Basic feature variant.	2011-09-16
1.10	Removed APM low power mode; added notes on host SPI polling after hibernate; added notes on PPS; updated overview; updated General spec	2011-10-12

1 Contents

2	Overview	6
2.1	General	6
2.2	Block diagram	7
2.3	Frequency Plan	7
2.4	General Specifications	7
3	Operation	9
3.1	Operating modes	9
3.2	Full on mode	9
3.2.1	Host port configuration	9
3.2.2	Power management system modes	9
3.2.3	Updates in ROM firmware	10
3.2.4	Patching ROM firmware	10
3.2.5	Self-Assistance – Client Generated EE usage	11
3.2.6	Almanac Based Positioning	11
3.2.7	5 Hz Navigation	11
3.3	Hibernate state	11
3.4	Reset state	12
4	Connectivity	13
4.1	Pad Assignments	13
4.2	Power supply	15
4.3	Host port configuration	16
4.4	Host port UART	16
4.5	Host port SPI	16
4.6	Host port I ² C	18
4.7	ON_OFF control input	19
4.8	Reset input	20
4.9	Antenna input	20
4.10	Active GPS antenna	21
4.10.1	Jamming Remover	21
4.11	Dead Reckoning I ² C bus	22
4.12	Time Mark TM	22
4.13	Wakeup	23
4.14	Interrupt inputs EIT and EIT2	23
4.15	ELCK signal	23
4.16	TSYNC signal	23

4.17	Mechanical Dimensions	23
4.18	Suggested pad layout	25
5	Electrical Specifications.....	26
5.1	Absolute Maximum Ratings	26
5.2	DC Electrical specifications.....	26
5.3	AC Electrical characteristics	27
6	Manufacturing	28
6.1	Assembly and Soldering	28
6.2	Moisture sensitivity.....	28
6.3	Marking	28
6.3.1	Module firmware features.....	29
6.4	Tape and reel	29
6.5	Environmental Specification	30
7	Reference design	31
7.1	Reference circuit diagram	31
7.2	PCB layout suggestion	32
7.2.1	Other electronics on mother board.....	33
7.2.2	Avoiding EMI.....	33
8	AP430 Application board for IT430.....	35
8.1	Board Terminal I/O-connector	35
8.2	Bill of materials	36
8.3	AP430 Circuit diagram.....	38
8.4	AP430 layout and assembly	39

2 Overview

2.1 General

The Fastrax IT430 is an OEM GPS receiver module with embedded GPS antenna and which provides the SiRFstar IV receiver, ref (1) functionality using the state of the art SiRF GSD4e chip (ROM variant). The module has ultra small form factor 9.6x9.6 mm, height is 1.85 mm nominal (2.15 mm max) and can be assembled with SMT reflow soldering. The Fastrax IT430 receiver provides low power and very fast TTFF together with weak signal acquisition and tracking capability to meet even the most stringent performance expectations.

The module provides complete signal processing from antenna input to host port in either NMEA messages or in SiRF OSP binary protocol. The module requires a single power supply VDD +1.8V. The host port is configurable to UART, SPI or I2C during power up. Host data and I/O signal levels are 1.8V CMOS compatible, inputs are 3.6V tolerable.

The SiRFstar IV provides a new feature called SiRFAware (also referenced as Micro Power Management mode), which enables fast TTFF for Snap start mode while consuming only 125 uA average current (typ.) in autonomous Hibernate state. The receiver does wakeup autonomously to calibrate internal GPS time and to collect ephemeris data while maintaining 1 sec Snap fix capability. The module has support and connectivity to optional external sensors for Dead Reckoning like 3-D Accelerometer and 3-D Compass on dedicated DR_I2C bus for Stationery Detection that aids navigation when receiver does not move during weak signal conditions like indoors.

The receiver is also optionally self-assisted since the Client Generated Extended Ephemeris (CGEE for 3 days) calculation is embedded in the software without any resources required from the host. The CGEE data is stored on external serial EEPROM memory on the dedicated DR_I2C bus (can be optionally transferred to/from host).

The SiRFstar IV contains also a CW Jammer Remover, which will track and remove up to 8 CW (Carrier Wave) type signals up to 80dBHz (equals to -90 dBm typ.) signal level.

The antenna input supports passive and active antennas with excellent out-of-band blocking rejection and provides also an input for externally generated antenna bias supply.

This document describes the electrical connectivity and main functionality of the Fastrax IT430 OEM GPS Receiver module.

2.2 Block diagram

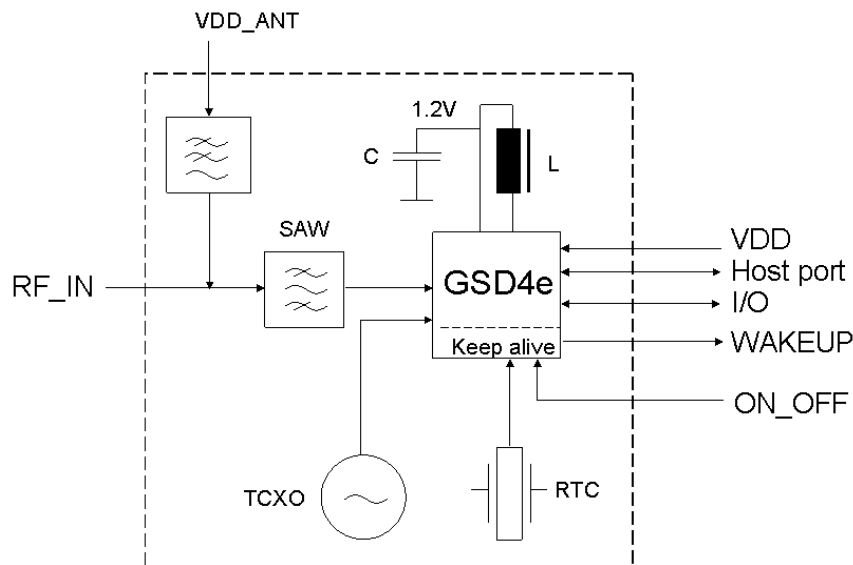

Figure 1 Block diagram

2.3 Frequency Plan

Clock frequencies generated internally in the Fastrax IT430 receiver:

- 32768 Hz real time clock (RTC)
- 16.369 MHz master clock (TCXO or crystal)
- 3142.96 MHz local oscillator of the RF down-converter

2.4 General Specifications

Table 1 General specifications

Receiver	GPS L1 C/A-code, SPS
Chip set & Tracking sensitivity	SiRF IV, GSD4e, ROM variant
Channels	48
Tracking sensitivity	-163 dBm typ.
Navigation sensitivity	-161 dBm typ.
Navigation sensitivity, re-acq.	-162 dBm typ.
Navigation sensitivity, cold acq.	-147 dBm typ.
Update rate (default)	1 Hz (configurable to 5Hz with ROM2.0 firmware rev 4.1.0 or above)
Position accuracy (<i>note 1</i>)	2.5 m (50%) typ. Horizontal 5 m (50%) typ. Vertical 0.01 m/s (50%) typ. Velocity
Max altitude/velocity	<60.000 ft/<1.000 knots
Time to First Fix, cold acq.	35 s typ. (<i>note 1</i>)
Time to First Fix, warm acq.	35 s typ. (<i>note 1</i>)
Supply voltage, VDD	+1.8 V +/- 5%
Power consumption (<i>note 2</i>)	56 mW (<i>Switcher mode</i>) or 68 mW (<i>LDO mode</i>) typ. @ VDD=1.8 V and Low power modes e.g. 10mW @ TricklePower 100ms/1Hz
Power consumption (Hibernate state)	36 uW typ. @ 1.8 V
External RF amplifier net gain range at RF Input (RF_IN)	0... +35 dB
Storage temperature	-40°C...+85°C

Operating temperature	-40°C...+85°C (note 3)
Host port configuration	SPI(default), UART or I ² C configurable via pull up/down resistor
Host port protocol	NMEA-0183 rev. 3.0 (configurable to SiRF binary OSP protocol)
Serial data format (UART)	8 bits, no parity, 1 stop bit
Serial data speed (UART)	4800 baud (configurable)
TM output (PPS)	200 ms high pulse, rising edge +/-1 µs @ full second GPS epoch

Note 1: With nominal GPS signal levels -130dBm.

Note 2: Module boots for internal 1.2V LDO regulator mode. Internal Switcher mode regulator reduces power consumption and requires a binary command from host to enable Switcher mode.

Note 3: Operation in the temperature range -40°C... -30°C is allowed but Time-to-First-Fix performance and tracking sensitivity may be degraded.

3 Operation

3.1 Operating modes

After power up the IT430 module boots from the internal ROM to Hibernate state. The module operation requires ON_OFF interrupt to wake up for Normal (Navigation, Full on) mode. Modes of operation:

- Full on (Navigation, Full Power)
 - Power management system modes
- Hibernate state
- Reset state

3.2 Full on mode

The module will enter Hibernate state after first power up with factory configuration settings. The Navigation mode will start after waking up from Hibernate state in cold start mode by sending ON_OFF signal interrupt pulse from host. Power consumption will vary depending on the amount of satellite acquisitions and number of satellites in track. This mode is also referenced as *Full on*, *Full Power* or *Navigation* mode.

Navigation is available and any configuration settings are valid as long as the VDD power supply is active. When the VDD is powered off, settings are reset to factory configuration and receiver performs a cold start on next power up.

VDD supply is intended to be kept active all the time and when needed the navigation activity is suggested to be controlled to low quiescent *Hibernate* state via ON_OFF control input; see also chapter 4.7. Autonomous wakeup after power up from *Hibernate* state to full on mode can be enabled by connecting WAKEUP signal to ON_OFF signal.

Navigation fix rate can be increased to 5 Hz by OSP binary message ID 136, Position Calc Mode set to xxxx x1xx (bin), e.g. 0x04, ref (3). Note that baud rate must be set high enough or message payload low enough in order to pass through all messages pending. Enabling 5 Hz navigation will increase typical current drain about 2 mA.

3.2.1 Host port configuration

User can select the host port configuration between UART, SPI (slave) and I²C (master/slave) during power up boot or reset. The port selection is not intended to be changed dynamically but only set once at power up. Default host port is SPI and other host port configurations requires external pull down or pull up resistor at CTS_N and RTS_N signals, see chapter 4.3 for details.

Default protocol for host communication is NMEA 4800 baud, ref (2). Protocol is switchable to SiRF binary OSP (One Socket Protocol, ref (3) by NMEA protocol command \$PSRF100.

Default NMEA message configuration: \$GPGGA, \$GPGSA and \$GPRMC rate every second (in this order) and \$GPGSV messages (can be 1... 4) every 5 seconds (sent after \$GPGSA message). Also CGEE related \$PSRF156 messages can be outputted at irregular interval. Message output and rate can be configured by NMEA message \$PSRF103. \$PSRF150 (OKtoSend) messages are also sent out when the receiver is ready to receive messages after wake up or when it is going into low-power mode and can't process input commands anymore.

3.2.2 Power management system modes

The IT430 module supports also SiRF operating modes for reduced average power consumption, ref (10) like Adaptive TricklePower™, Push-to-Fix™ and SiRFAware™ modes:

1. Adaptive TricklePower (ATP): In this mode the receiver stays at Full on power state for 200... 900ms and provides a valid fix. Between fixes with 1... 10 sec interval the receiver stays in Hibernate state. ATP mode

is configurable with SiRF binary protocol message ID151 (ref 3). The receiver stays once in a while in Full on power mode automatically (typ. every 1800 sec) to receive new ephemeris data from rising satellites or if received signal levels drop below certain level.

2. Push-to-Fix (PTF): In this mode the receiver is configured to wake up periodically, typically every 1800 sec (configurable range 10... 7200 sec), for position update and to collect new ephemeris data from rising satellites. Rest of the time the receiver stays in Hibernate state. When position update is needed, the host can wake up the receiver by ON_OFF control input interrupt (pulse low-high-low >90us after which the receiver performs either Snap or Hot start and a valid fix is available within 1... 8 seconds typ. This mode is configurable with SiRF binary protocol message ID151 & 167.
3. SiRFAware (aka Micro Power Management mode, MPM): In this mode the receiver is configured to wake up periodically for 18 sec, typically every 1800 sec, to collect new ephemeris data from rising satellites, and once in a while (rate depends on temperature change) for 250 ms to calibrate internal navigation state and GPS time estimate. Rest of the time the receiver stays in Hibernate state and module achieves 125 uA typ. average current drain. The host wakes up the receiver by ON_OFF control input interrupt (pulse low-high-low >90us) to Full on power mode after which the receiver performs Snap start and a valid fix is available within 1 second typ. After valid fix, operation can return back to Micro Power Management mode by re-sending the configuration binary message from host. This mode is configurable with SiRF OSP (One Socket Protocol) binary protocol message MID218 MID218 and it requires that fix is valid prior entering the mode.

These power management modes are also configurable with SiRF OSP binary protocol message MID 218, Power Mode Request. Note that position accuracy can be somewhat degraded in power management modes when compared to full power operation.

3.2.3 Updates in ROM firmware

The firmware in the internal ROM memory is expected to be updated from time to time. A firmware update may add new firmware features. New firmware will also affect the need for possible patch code handling. This manual revision describes rev. 4.1.0 aka ROM2.0 device operation.

As the availability of previous ROM firmware revisions can't be guaranteed, it is important that any host control operation, including e.g. possible patch code download, is flexible and allows IT430 ROM firmware to be updated. This requires that any patch code stored at host or at external EEPROM can be either omitted or updated at later stages in order to match with future IT430 ROM firmware revisions.

Any new ROM firmware revision will also issue a new module revision due to Bill-of-Materials (type code) of the IT430 module since the silicon order code and firmware revision will change accordingly. Customers are advised to follow up Fastrax Change Notices on IT430 ROM firmware updates.

3.2.4 Patching ROM firmware

The firmware that is associated with IT430 is executed for internal ROM memory. It is a normal practice that firmware patches may be provided from time to time in order to address ROM firmware issues as a method of implementing bug fixes. Patch firmware (max. size 24 kB) and downloading tools are available via Fastrax support.

Patch is stored by default on external EEPROM at DR_I²C bus or at host. Note that power down will clear internal patch RAM (and thus also patch) but patch is automatically re-issued from external EEPROM after next power up.

The usage of external EEPROM allows also custom made patch code (CCK, Customer Configuration Kit) tailored for any specific configuration need like baud rate, protocol, I/O configuration etc.; contact Fastrax support for details on CCK.

3.2.5 Self-Assistance – Client Generated EE usage

The IT430 module supports Client Generated Extended Ephemeris (CGEE), which allows fast TTFF 10 sec typ. for 3 days. The CGEE data is generated internally from satellite ephemeris as a background task and thus host should allow the IT430 to navigate a few minutes and to collect ephemeris and to process CGEE data from as many satellites as possible before entering Hibernate state.

The CGEE feature is enabled by default when an external EEPROM is connected to DR_I²C bus for CGEE data storage; see chapter 4.11. The operation requires that power supply is kept active all the time for fastest TTFF; control navigation activity by the host via the ON_OFF control input. The CGEE data storage can be controlled by NMEA message \$PSRF120 or OSP binary message ID 232, Sub ID 253.

The CGEE data can be also stored optionally to host; contact Fastrax support for availability and details, ref (8).

3.2.6 Almanac Based Positioning

User can enable so called Almanac Based Positioning (ABP, see NMEA command \$PSRF103 or OSP command ID 136), which allows fast cold starts TTFF 22 sec typ. since broadcast ephemeris data is not need from visible satellites but the factory set (or broadcast or pushed) Almanac data is used for positioning. When broadcast ephemeris data gets available from visible satellites, the navigation will use automatically more precise ephemeris data for positioning. When ABP is enabled, the navigation message (e.g. NMEA \$GPRMC) will indicate when ABP positioning is being used in navigation (\$GPRMC: Mode=R).

The positioning accuracy is in the order of few hundred meters to kilometers and is usable mainly to coarse positioning (e.g. to find out in which country/state/district the receiver is located). Position accuracy is also expected to degenerate when actual Ephemeris/Almanac starts to differ from the factory set Almanac data in power down/on cycles. Host may try to overcome this problem by either keeping the power supply active all the time using Hibernate or by polling latest broadcast Almanac from the module (by OSP Message ID 146) prior power down and then pushing the Almanac back to module (by OSP Message ID 130) at next power up after waking up from Hibernate state. Note the Almanac data broadcast takes 12.5 minutes and thus allow the module to navigate in Full on mode at least for this period.

3.2.7 5 Hz Navigation

User can enable 5 Hz navigation rate by NMEA or binary command (ROM2.0 onwards). Prior changing the navigation rate from 1 Hz to 5 Hz suggestion is to increase host baud rate high enough, from 4800 baud to at least 5x by NMEA command \$PSRF100, e.g. 38400 baud minimum in order to enable 5 times more message throughput.

NMEA command for 5 Hz navigation is \$PSRF103,00,6,00,0*23. And 1Hz navigation can be restored by command \$PSRF103,00,7,00,0*22. In OSP binary protocol the command is MID 136, Position Calc Mode set to 0x04.

3.3 Hibernate state

Hibernate state means a low quiescent (20uA typ.) power state where only the internal I/O Keep Alive, non-volatile RTC, patch RAM and backup RAM block is powered on. Other internal blocks like digital baseband and RF are internally powered off. The main supply input VDD shall be kept active all the time, even during Hibernate state. Waking up from and entering in to Hibernate state is controlled by host interrupt at ON_OFF control input (rising edge toggle low-high-low >90us).

During Hibernate state the I/O Keep Alive is still active, thus I/O signals keep respective states except TX and RX signals, which are configured to high input impedance state.

The receiver wakes up from Hibernate state on the next ON_OFF interrupt (at rising edge) using all internal aiding like GPS time, Ephemeris, Last Position etc. resulting to a fastest possible TTFF in either Hot or Warm start modes.

3.4 Reset state

Reset state is entered internally after power up until the internal RTC clock wakes up after which internal reset state is relaxed and module boots to Hibernate state. Host can override reset state via RESET_N input, low state active. Normally external reset override is not required but if power shall be removed abruptly see chapter 4.2 for reset suggestion.

Note that reset clears data RAM content, e.g. downloaded ROM patch code. User can overcome this problem by using patch storage to external EEPROM and thus the module is able to re-issue patch code header back to internal patch RAM after waking up from successive Hibernate state. Backup RAM content is not cleared and thus fast TTF is possible after reset and system configuration settings are sustained.

4 Connectivity

4.1 Pad Assignments

The I/O signals are available as soldering (castellated) pads on the bottom side of the module. These pads are also used to attach the module on the motherboard. All digital I/O signal levels are 1.8V CMOS compatible and inputs are 3.6V tolerable. All unconnected I/O signals can be left unconnected when not used, unless instructed to use external pull up/down resistor.

Table 2 Pad assignment

Contact	Signal	I/O type Full on	I/O type Hibernate	I/O type Reset	Signal description
1	VDD	P,I	P,I	P,I	Power supply input +1.8V nom. <i>De-couple externally with e.g. 4.7uF low ESR ceramic capacitor.</i>
2	DR_I2C_DIO	S,C,B	S,C,B	HZ	- GPIO0 - Dead reckoning I ² C host bus data (SDA). Use external pull up resistor when bus is used. <i>Connect to GND or pull up when not used.</i>
3	VDD_ANT	P,I	P,I	P,I	Antenna bias power supply input up to +/-5.5V. <i>De-couple signal further externally, see Application Circuit Diagram. Connect to GND when not used.</i>
4	GND	G	G	G	Ground
5	GND	G	G	G	Ground
6	RF_IN	A,I,O	A,I,O	A,I,O	Analog Antenna input (50 ohm), Antenna bias voltage output (filtered from VDD_ANT)
7	GND	G	G	G	Ground
8	GND	G	G	G	Ground
9	GND	G	G	G	Ground
10	GND	G	G	G	Ground
11	CTS_N	S,C,B, PD(a)	S,C,B, PD	HZ	- GPIO6 - SPI_CLK slave SPI clock input (CLK) - UART_CTS_N UART Clear to Send (CTS), active low - Host port boot strap, see 4.3 <i>Pull up externally for UART.</i>
12	RESET_N	C,I,PU	C,I,PU	C,I,PU	External reset input, active low. <i>Can be left unconnected when not used.</i>
13	RTS_N	S,C,B, PU(a)	S,C,B, PU	HZ	- GPIO7 - SPI_SS_N slave SPI chip select (CS#), active low - UART_RTS_N UART Request to Send (RTS), active low - Host port boot strap, see 4.3 <i>Can be left unconnected when not used.</i>
14	GND	G	G	G	Ground
15	TX	S,C,B	HZ	HZ	- SPI_DO slave SPI data output (MISO) - UART_TX UART data transmit (TX) - I2C_CLK I ² C bus clock (SCL)
16	RX	S,C,B	HZ	HZ	- SPI_DI slave SPI data input (MOSI) - UART_RX UART data receive (RX). <i>Must be</i>

Contact	Signal	I/O type Full on	I/O type Hibernate	I/O type Reset	Signal description
					<i>driven by host or use external pull up resistor (UART RX).</i> - I2C_DIO I ² C bus data (SDA)
17	ON_OFF	S,C,B	S,C,B	S,C,B	Power control input used to command the module On (Navigation) or Off (Hibernate). <i>Must be driven by the host.</i>
18	GND	G	G	G	Ground
19	GND	G	G	G	Ground
20	TM	S,C,B	S,C,B	HZ	- GPIO5 - Time mark output signal (<i>default 1PPS</i>) - Optionally GPS_ON, power control output signal for e.g. external LNA bias control. - Optionally RTC_CLK, buffered RTC clock output. <i>Can be left unconnected when not used.</i>
21	WAKEUP	C,O	C,O	C,O	Wakeup output for control of external regulator, e.g. battery to 1.8V for the VDD supply input when full power mode is entered. Can be used also externally for active antenna bias control, active high = high current/bias on. <i>Can be left unconnected when not used.</i>
22	EIT	S,C,B	S,C,B	HZ	- GPIO4 - External interrupt input signal. Provides an interrupt on either high or low logic level. <i>Connect to GND when not used.</i>
23	EIT2	S,C,B	S,C,B	HZ	- GPIO8 - EIT2 external interrupt input #2. Provides an interrupt on either high or low logic level or edge-sensitive interrupt. <i>Connect to GND when not used.</i>
24	GND	G	G	G	Ground
25	ECLK	S,C,B	S,C,B	HZ	- GPIO3 - Message_Waiting (output) when in UART handshaking or SPI host port mode - Reserved for ECLK clock input for frequency aiding applications. <i>Connect to GND when not used.</i>
26	TSYNC	S,C,B	S,C,B	HZ	- GPIO2 - Reserved for TSYNC that is the time transfer strobe input used in A-GPS precise time aiding <i>Connect to GND when not used.</i>
27	DR_I2C_CLK	S,C,B	S,C,B	HZ	- GPIO1 - Dead reckoning I ² C host bus clock (SCL). Use external pull up resistor when bus is used. <i>Connect to GND or pull up when not used.</i>
28	GND	G	G	G	Ground

Note (a): Pull Up/down resistor present only shortly after power up.

Legend: A=Analogue, B=Bidirectional, C=CMOS, G=Ground, HZ=High Impedance, I=Input, O=Output, P=Power, PU=Internal Pullup 86 kohm typ., PD=Internal Pulldown 91 kohm typ., S=Schmitt Trigger (when Input). Note that with Birectional I/O the firmware has control for input vs. output I/O type depending on the firmware function.

4.2 Power supply

The IT430 module requires only one power supply VDD. Keep the supply active all the time in order to keep the non-volatile RTC & RAM active for fastest possible TTFF.

VDD supply intended to be kept alive all the time. First power up may take 300ms typ. due to internal RTC startup time (may increase up to 5 seconds at cold temperature) after which the module will enter to Hibernate state. The host may try wakeup the module via successive ON_OFF interrupts sent every second until the host port messages are outputted and/or WAKEUP output is at high state.

When power supply is intended to be removed, it is suggested that prior power removal a serial message in binary (MID 205) or NMEA format (\$PSRF117,16*0B<CR><LF>) is sent to module to shut down firmware operations orderly. Otherwise e.g. external EEPROM may get corrupted if power down happens in the middle of EEPROM writing, which may increase in TTFF. If external EEPROM is also used for ROM patch code, the abrupt power removal may cause patch code corruption that may end to system failure.

Second option for orderly shutdown is to send ON_OFF interrupt prior VDD removal. Operations shutdown may take anything between 10 to 900 ms depending upon operation in progress and messages pending and hence is dependent upon serial interface speed and host port type.

If it is likely that VDD supply will be removed abruptly, suggestion is to add external voltage monitor to detect under voltage condition below 5% nominal supply voltage and to drive RESET_N signal to reset condition (low state). This important especially when external EEPROM or data storage at host is used. VDD supply off-time is suggested to be over 10 seconds to next power up in order to clear all internal backup RAM content and to minimize risk for wrong backup data.

Main power supply VDD current varies according to the processor load and satellite acquisition. Typical VDD peak current is 56 mA (typ.) during waking for Full on power up (short peaks can be up to 90mA). Typical VDD current in low power Hibernate state is 20uA. The external power supply can be using dual low/high current modes, which can be controlled via the WAKEUP output signal (high current = WAKEUP high) as indication when full power is required by the module. The external power supply should be able to provide full current to VDD within 9 ms after WAKEUP low-to-high transition.

The internal 1.2V regulator is powered from VDD supply and it boots for LDO mode. The internal 1.2V power supply includes also Switcher mode regulator ($f = 8$ MHz). The host may reduce power drain by enabling the Switcher mode via sending a binary message from the host (Message ID 178 TrackerIC, Sub ID 2 TrackerConfig; contact Fastrax support for details).

By-pass the VDD supply input by a low ESR ceramic de-coupling capacitor (e.g. 4.7 uF) placed nearby VDD pin to ensure low ripple voltage at VDD. Ensure that the VDD supply ripple voltage is low enough: 54 mV(RMS) max @ $f = 0 \dots 3$ MHz and 15 mV(RMS) max @ $f > 3$ MHz.

NOTE

VDD supply is intended to be active all the time. Abrupt removals of VDD supply are not suggested and when required, e.g. when using CGEE storage to external EEPROM, use an external voltage detector to force reset at VDD under voltage conditions.

De-couple the VDD input externally with e.g. 4.7uF low ESR ceramic capacitor connected to GND. The module has also internal a low ESR (~0.01 ohm) by-pass capacitor at VDD supply input. Ensure that the external regulator providing VDD supply is suitable for loads with low ESR ceramic capacitors.

VDD supply ripple voltage: 54 mV(RMS) max @ f = 0... 3MHz and 15 mV(RMS) max @ f > 3 MHz

4.3 Host port configuration

User can select the host port configuration between UART, SPI (slave) and I²C (master/slave) during power up boot. At system reset, the host port pins are disabled, so there will be no port conflict occurring. Depending on the host port type, the software enables the correct port drivers, sets up the port hardware, configures the pins according to the port type and begins operations.

The port selection is not intended to be changed dynamically but only set once at power up. Default host port is SPI (selected by internal pull up/down resistors that are present during power up) and other host port configurations requires connection of external pull down (to 0V) or pull up (to 1.8V) resistor at CTS_N and RTS_N pins, see table below.

Table 3 Host port boot strap

Host port	RTS_N	CTS_N
UART	-	Pull up 10 kohm
SPI	-	-
I ² C	Pull down 10 kohm	-

4.4 Host port UART

UART is normally used for GPS data reports and receiver control. Serial data rates are selectable from 1200 baud to 1.8432 Mbaud. Default baud rate is 4800 baud; default protocol is NMEA (protocol and baud rate can be configured by NMEA \$PSRF100 message). RX signal is suggested to be pulled up externally when not used.

4.5 Host port SPI

The host interface SPI is a slave mode SPI:

- Supports both SPI and Microwire formats
- An interrupt is provided when the transmit FIFO and output serial register (SR) are both empty
- The transmitter and receiver each have independent 1024B FIFO buffers
- The transmitter and receiver have individual software-defined 2-byte idle patterns of 0xA7 0xB4
- Clock polarity: default SPI mode 1 (CPOL=0; CPHA=1) i.e. data is captured on the clock's falling edge and data is propagated on a rising edge
- MSB is sent first
- SPI detects synchronization errors and is reset by software

- Supports a maximum clock of 6.8MHz
- Signals: TX (SPI_DO, MISO), RX (SPI_DI, MOSI), CTS_N (SPI_CLK) and RTS_N (SPI_SS_N)
- Supports GPIO3 Message_Waiting output (high state) (from ROM2.0 onwards).

The SPI bus is a synchronous serial data link and a 'de facto' standard named by Motorola. For further information see e.g. Wikipedia: http://en.wikipedia.org/wiki/Serial_Peripheral_Interface_Bus.

Microwire is a restricted subset of SPI and a trademark of National Semiconductor. For details see e.g. <http://www.national.com/an/AN/AN-452.pdf> ref (4).

At system level the slave has no way of forcing data to the master to indicate it is ready for transmission; the master must poll the client periodically. Since the specified idle byte pattern for both receive and transmit is 0xB4 0xA7, the master can transmit this idle pattern into the slave repeatedly. If the master receives idle patterns back from the slave, it indicates that the slave currently has nothing to transmit but is ready to communicate. Default protocol is NMEA (protocol can be configured by NMEA \$PSRF100 message).

On initial power up after sending wake up ON_OFF pulse, the first message to come out of the module is the OK_TO_SEND message. Note that it takes about 100 ms from wake up for the SPI drivers to get initialized. If the host starts to communicate via SPI bus too early before the 100 ms has elapsed after ON_OFF pulse, it may cause wrong host boot strap detection. The host may also use GPIO 3 (ECLK) signal (high state; from ROM2.0 onwards) for indication when SPI slave is ready to for communication and has a message In FIFO.

On the receive side, the host is expected to transmit idle pattern 0xA7 0xB4 when it is querying the module's transmit buffer, unless it has traffic to send to the module. In this way, the volume of discarded bytes is kept nearly as low as in the UART implementation because the hardware does not place most idle pattern bytes in its RX FIFO. The module will also assert GPIO 3 to high state (from ROM2.0 onwards) whenever it has data in the module transmit FIFO. The host can observe this GPIO3 (ECLK) signal to know when to poll the receiver for data.

The FIFO thresholds are placed to detect large messages requiring interrupt-driven servicing. On the transmit side, the intent is to fill the FIFO only when it is disabled and empty. In this condition, the SPI driver software loads as many queued messages as can completely fit in the FIFO. Then the FIFO is enabled. The host is required to poll messages until idle pattern bytes are detected or when GPIO3 (ECLK) is at low state. At this point the FIFO is empty and disabled, allowing the SPI driver to again respond to an empty FIFO interrupt and load the FIFO with any messages in queue.

When switching the module to hibernate state using orderly shutdown with an ON_OFF pulse, by a low power mode or by OSP/NMEA command message, the module will continue to run until the SPI transmit/output buffers are emptied. If the host flow stops polling or turns off the SPI clock before the SPI FIFO is empty and OK_TO_SEND message is sent from module to host, the module will never turn off.

Default protocol is NMEA (protocol can be configured by NMEA \$PSRF100 message; commands containing UART baud rate: use default speeds 4800 baud for NMEA and 115200 baud for binary OSP).

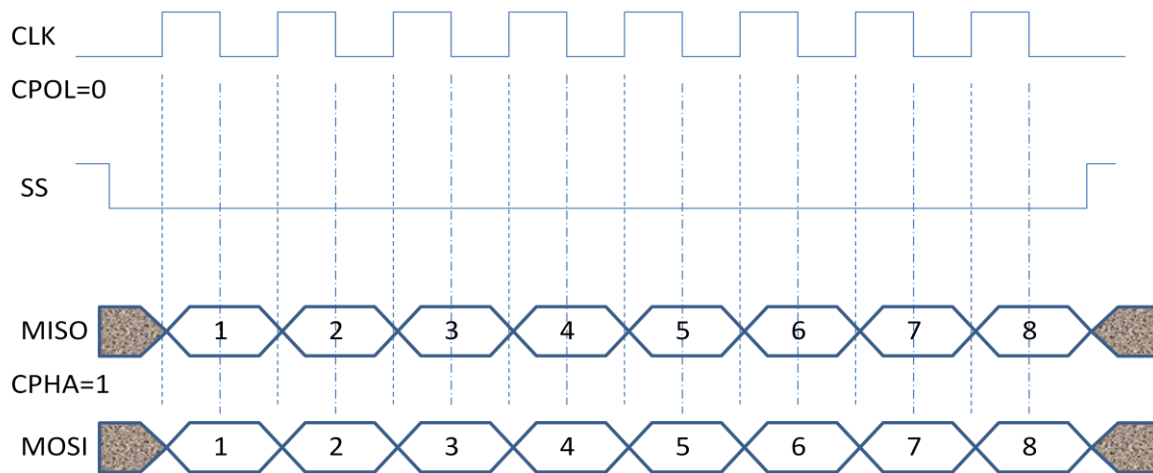

Figure 2 SPI host port timing, SPI mode 1 (assuming one byte transfer)

4.6 Host port I²C

The I²C host port interface supports:

- Default speed is 400kbps, configurable to 100kbps (by OSP Message ID 178, Sub ID 2)
- Default operating mode is multi-master
 - Transmit side operates as master by seizing the I²C bus when detected idle
 - Receive side operates as a slave when another master seizes bus and transmits to this address
- Configurable also to slave mode (by OSP Message ID 178, Sub ID 2)
- Default I2C address values are (configurable by OSP Message ID 178, Sub ID 2):
 - RX 0x60, TX 0x62
- Individual transmit and receive FIFO lengths of 64B
- Signals: TX (I2C_CLK, SCL) and RX (I2C_DIO, SDA) and requires external pull up resistors (to +1.8... +3.6V) on both signals somewhere in the system. Pull up resistor value depends on used clock speed and signal line stray capacitance; suggested pull up is e.g. 2.2kohm.

The operation of the I²C in multi-master mode with a master transmit and slave receive mimics a UART operation, where both module and host can independently freely transmit. Default protocol is NMEA (protocol can be configured by NMEA \$PSRF100 message; commands containing UART baud rate: use default speeds 4800 baud for NMEA and 115200 baud for binary OSP).

The I²C bus operation is specified in detail including evaluating tools, application notes and drivers by Philips Semiconductors, see http://www.nxp.com/acrobat_download2/literature/9398/39340011.pdf ref (5).

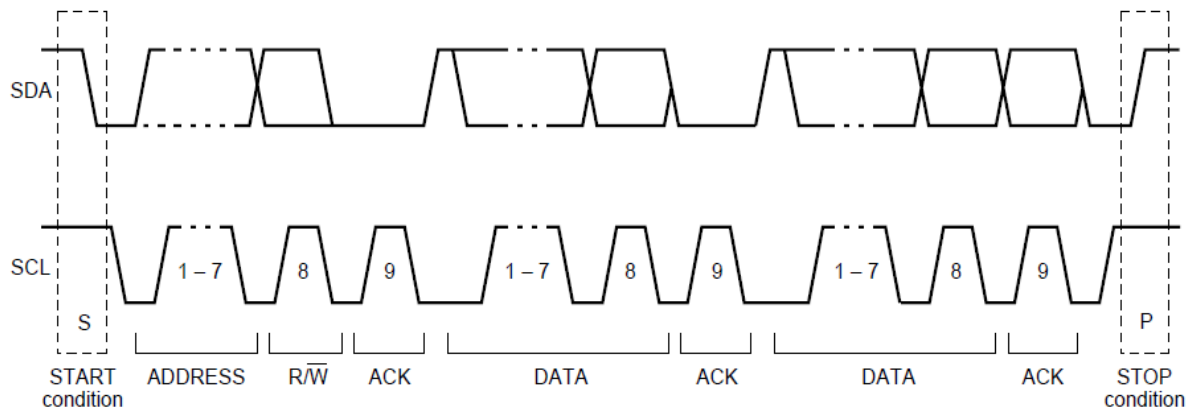

Figure 3 I²C host port data transfer

NOTE

When host port is configured to I²C bus use external pull up resistors (e.g. 2.2 kohm to +1.8... +3.6 V) at both signals.

4.7 ON_OFF control input

The ON_OFF control input must be used by the host to wake up the module after first power up and to control the receiver activity between Normal and Hibernate states and also to generate interrupt in TricklePower, Push-to-Fix and SiRFaware modes of operation.

The module will boot to Hibernate state after power up. First ON_OFF interrupt wakes up the module for Normal (Navigation) operation. Consequent ON_OFF interrupts switch the operation mode between Hibernate and Navigation modes. Autonomous wakeup after power up from Hibernate state to full on mode can be enabled by connecting WAKEUP signal to ON_OFF signal, see also chapter 4.13.

In NMEA protocol \$PSRF150 (OKtoSend) messages are sent out when the receiver is ready to receive messages or when it is going into low-power mode and no more messages should be sent from the host. When Full power is restored, the first message sent is \$PSRF150,1*3E<CR><LF> and when power is going to be reduced to Hibernate state, the last message sent is \$PSRF150,0*3F<CR><LF>. Similar message is also available in binary OSP protocol (MID 18) that is sent when going into low-power mode and no more messages should be sent from the host.

The ON_OFF interrupt is generated by rising edge of a low-high-low pulse, which should be longer than 90us and less than 1s (suggestion is abt. 100ms pulse length). Do not generate ON_OFF interrupts less than 1 sec intervals. Especially take care that any multiple switch bounce pulses are filtered out.

During Hibernate state the I/O Keep Alive is still active, thus I/O signals keep respective states except TX and RX signals, which are configured to high input impedance state.

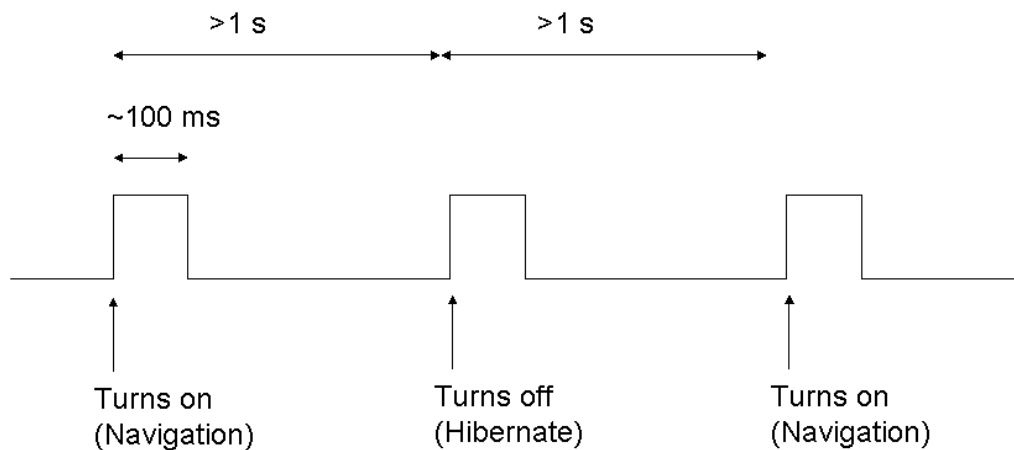

Figure 4 ON_OFF timing

The ON_OFF control input is configurable via a binary message from the host (Message ID 178 TrackerIC, Sub ID 2 TrackerConfig or via custom patch code; contact Fastrax support for details).

NOTE

Do not generate multiple ON_OFF interrupts less than 1 sec intervals. Especially filter out multiple pulses generated by a mechanical switch bounce.

4.8 Reset input

The RESET_N (active low) signal provides external override of the internally generated power up/down reset. Normally external control of RESET_N is not necessary. When power supply VDD may be abruptly removed, suggestion is to use externally generated reset by means of external VDD voltage monitor.

When RESET_N signal is used, it will force volatile RAM data loss (e.g. ROM patch code is lost if external EEPROM is not used). Note that Non-Volatile Backup RAM content is not cleared and thus fast TTF is possible and Patch code (if used) is recovered from external EEPROM after reset. The input has internal pull up resistor 86 kohm typ. and leave it not connected (floating) if not used.

4.9 Antenna input

The module supports passive and active antennas. The antenna input RF_IN impedance is 50 ohms and it provides also a bias supply low-pass filtered form VDD_ANT supply. The RF input signal path contains first a SAW band-pass filter, which provides good out-of-band protection against GPS blocking caused by possible near-by wireless transmitters, ref (9).

Note that antenna input is ESD sensitive. With passive antennas the ESD performance can be improved by connecting VDD_ANT supply input to GND. Also an external TVS diode with low capacitance (<0.5pF, e.g. Infineon ESDOP2RF) can be used to improve RF-input ESD capability.

With passive antenna the suggested power mode is LDO (default) since Switcher mode will reduce sensitivity by about 4dB (typ.). Note that with an active antenna usage there is no effect of the power mode used and both LDO and Switcher mode give equal performance.

NOTE

Use only LDO (default) power mode with Passive Antenna.

NOTE

With Passive antennas leave VDD_ANT not connected or connect to GND.

4.10 Active GPS antenna

The customer may use an external active GPS antenna when antenna cable loss exceeds > 1dB. It is suggested the active antenna has a net gain *including cable loss* in the range from +7 dB to +35 dB (with ROM2.0 firmware and above the internal system gain control is automatic). Specified sensitivity is measured with external low noise ($NF \leq 1\text{dB}$, $G \geq 15\text{dB}$) amplifier, which gives about 2dB advantage in sensitivity when compared to a passive antenna.

An active antenna requires certain bias voltage, which can be supplied externally via VDD_ANT supply input. Decouple externally the VDD_ANT input; see the application circuit diagram in chapter 6. The external bias supply must provide limitation of the max current below 150mA during e.g. antenna signal short circuit condition.

When the module is in Hibernate state, the antenna bias can be switched off externally by using WAKEUP signal output to switch off VDD_ANT supply, see e.g. Application Circuit Diagram.

NOTE

With Active GPS Antenna provide externally VDD_ANT supply suitable for the active antenna used. The VDD_ANT supply must provide also short circuit protection externally, rated current 70mA, abs. max. 150mA.

4.10.1 Jamming Remover

Jamming Remover (aka CW Detection) is an embedded HW block that detects, tracks and removes up to 8 pcs CW (Carrier Wave) type signals up to 80 dBHz (-90 dBm) signal levels. By default the Jamming Remover is disabled and usage requires an OSP binary command Message ID 220 (CW Configuration) to enable.

Jamming Remover can be used for detecting and solving EMI problems in the customer's system and it is effective against e.g. narrow band clock harmonics. Use PC utility SiRFLive to indicate and detect CW EMI signals, see also SiRFLive user manual for details. Jammer detection sensitivity is about 55 dBHz and below this threshold jammers are not detected.

Note that Jamming Removal is not effective against wide band noise (e.g. from host CPU memory bus), which cannot be separated from thermal noise floor and which increases effective noise floor and reduces GPS signal levels. When enabled, Jammer Remover will increase current drain by about 2 mA but impact on GPS performance is low at modest Jammer levels; however at high Jammer levels 70... 80 dBHz the signal sampling (ADC) starts to get saturated, which will reduce GPS signal levels.

See ref (6) Application Note for details on Jammer Remover usage.

4.11 Dead Reckoning I²C bus

The DR_I²C bus (master) provides optional connectivity to the following devices:

- Optional connectivity to EEPROM for Client Generated Extended Ephemeris (CGEE) data storage
- Optional ROM patch code storage to EEPROM and upload to IT430
- Optional MEMS sensors (e.g. support for 3-D Accelerometer or 3-D Compass for Stationery Detection with ROM2.0 firmware).

The DR I²C interface provides means for patch code and CGEE data storage via an external EEPROM. Once the patch or the CGEE data is stored to the EEPROM, the module will detect automatically the presence of these data blocks even after power removal during next wakeup and thus host renovation of the patch or CGEE data is not needed.

When enabled the optional 3-D Accelerometer MEMS sensor provides feature for Stationary Detection, which allows to reduce the position spread when in stationary condition during weak GPS signals e.g. indoors. When MEMS Accelerometer sensor is used connect also the sensor's INT output to IT430's EIT input, which allows the system to wake up more frequently during SiRFAware low power operation mode when GPS signal visibility is missing assuming that movement will result to improved GPS visibility.

When enabled the optional 3-D Magnetometer (Compass) provides attitude (heading) information that aids navigation in velocity heading.

The bus signals require external pull up resistors 2.2kohm on both SCL and SDA signals. Connect both signals to GND (or pull up) when not used. The sensor measurement data output is available via binary OSP message MID 72. Note that sensors are disabled by default and need to be enabled by binary Message ID 234, Sub ID 2 (message payload in hex EA 02 03).

DR I²C interface supports:

- Common EEPROM data formats (STMicroelectronics M24M01-R, 1 Mbit device; ROM2.0 onwards: Microchip 512 kbit 24AA512T-I/MF and 1 Mbit 24AA1025T-I/SN)
- Common sensor formats (ROM2.0 onwards: Kionix, KXTF9-4100 and Aichi Steel, AMI304)
- Typical data lengths (command + in/data out) of several bytes
- Standard I²C bus maximum data rate 400kbps; minimum data rate 100kbps
- Sensor data messages (ROM2.0, binary OSP):

		<u>Message ID, Sub ID</u>
○ Sensor Configuration	Input	234, 1
○ Sensor Enable	Input	234, 2 Note: sensors are disabled by default
○ Sensor Data Message	Output	72,1
○ Receiver State Message	Output	72,3 Note: static/moving indication

NOTE

DR_I²C bus requires external pull up resistors (e.g. 2.2 kohm to +1.8... +3.6 V) at both signals.

4.12 Time Mark TM

The TM output signal provides pulse-per-second (PPS) output pulse signal for timing purposes. Pulse length (high state) is 200ms and it has 1us accuracy synchronized at rising edge to full UTC second with nominal GPS signal levels. The TM will output PPS after a few seconds from first fix when the fix epoch is synchronized to full second. The PPS output is valid when navigation is valid and will also continue after valid fix is lost by a certain navigation

DR timeout (default configuration 15 seconds); the timeout is configurable by OSP binary protocol MID 136, DR Time Out. User can also enable NMEA \$GPZDA message that is sent right after the TM pulse just sent.

The firmware may support optionally other output function configuration from TM signal, like GPS_ON output for e.g. external LNA power control or RTC_CLK, which outputs buffered RTC clock signal at 32768 Hz; contact Fastrax support for details on I/O configuration.

4.13 Wakeup

The WAKEUP output signal provides indication to e.g. external power supply when full power is required by the module. Polarity is active high = high current mode. The external power supply should be able to provide full current to VDD within 9ms after WAKEUP low->high transition.

WAKEUP signal can be also used externally to switch off the Active Antenna Bias supply voltage (VDD_ANT) during Hibernate state; polarity is active high = VDD_ANT active. The WAKEUP signal has a short pulse after initial power up due to internal state machine settling; this allows also autonomous wakeup to Full on Navigation mode after initial power up when the WAKEUP signal is connected to ON_OFF input.

NOTE

Autonomous wakeup to Full Navigation mode after initial power up can be enabled by connecting the WAKEUP signal to ON_OFF input.

4.14 Interrupt inputs EIT and EIT2

The EIT and EIT2 are external, level sensitive interrupt inputs. EIT2 pin is also configurable as an edge-sensitive input. Both pins are disabled at initial power-up and usage is configured by the software (firmware support is up ROM release or patch).

When using an external accelerometer on DR_I²C bus, connect the interrupting output of the sensor to the EIT input.

When not used connect these inputs to ground.

4.15 ELCK signal

The ECLK is reserved for external clock input with special variant for A-GPS frequency aiding and is disabled by default. With firmware 4.1.0 (aka ROM2.0) onwards the signal function is GPIO3 Message_Waiting (output, active = high state), which is enabled when in SPI or UART handshaking host port modes. The signal is suggested to be left floating or pulled to GND with external resistor 10 kohm when not used.

4.16 TSYNC signal

TSYNC input is reserved for external time aiding with a special variant used for A-GPS. The input is suggested to be connected to GND when not used.

4.17 Mechanical Dimensions

Module size is square 9.6 mm (width), 9.6 mm (length) and 1.95 mm (height, 2.25 mm max). General tolerance is ±0.3 mm. Note pin 1 polarity mark on the corner on the shield.

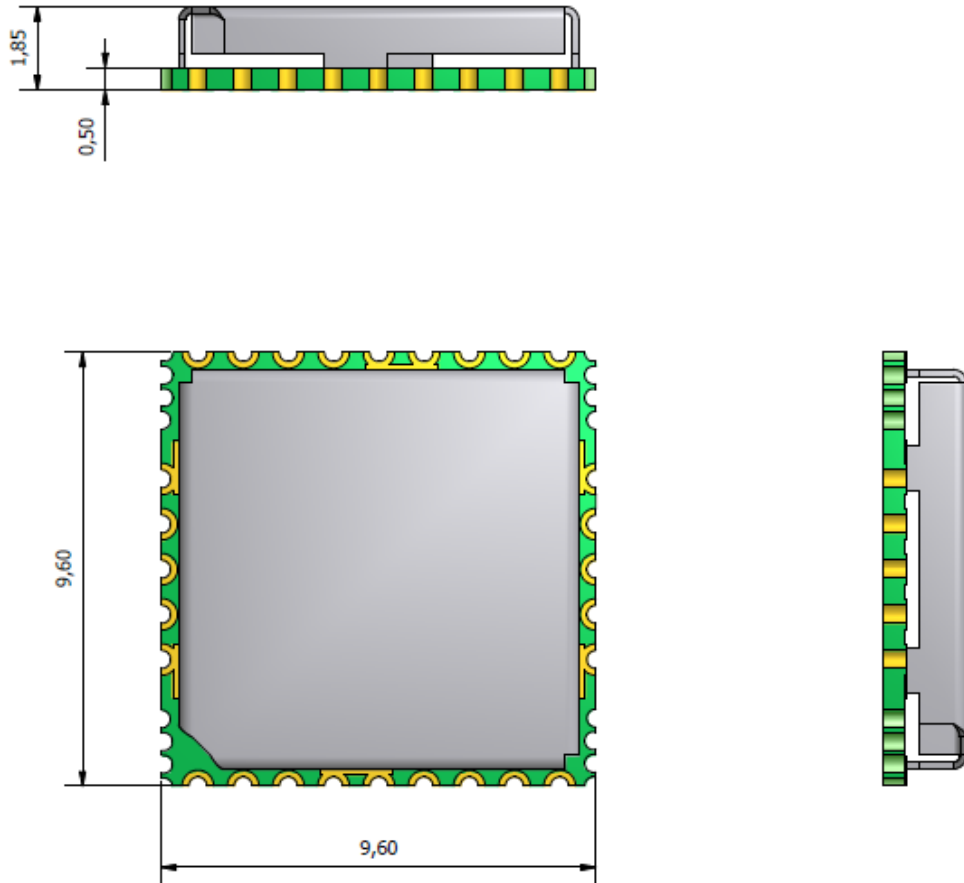

Figure 5 Mechanical Dimensions

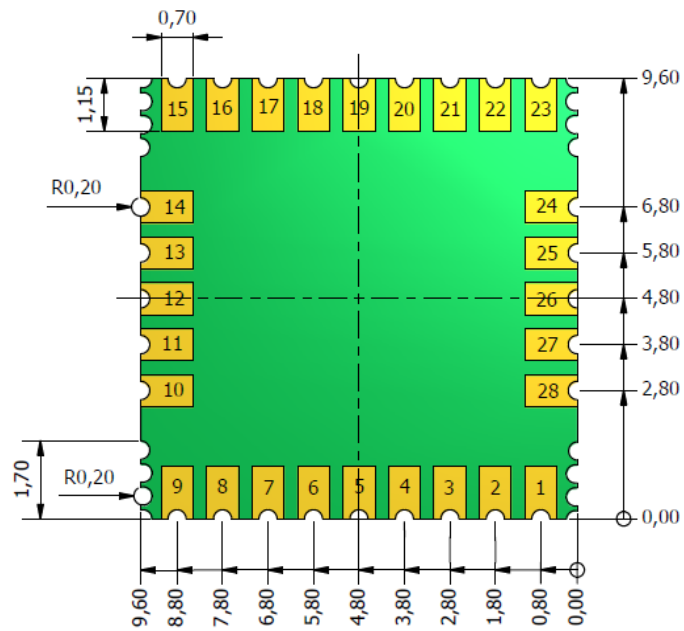

Figure 6 Pin numbering and dimensions, bottom view

4.18 Suggested pad layout

Suggested paste mask openings equal to pad layout. Note the keepout (void area) 4.8x7.2mm for copper & trace & components for all layers under the embedded antenna.

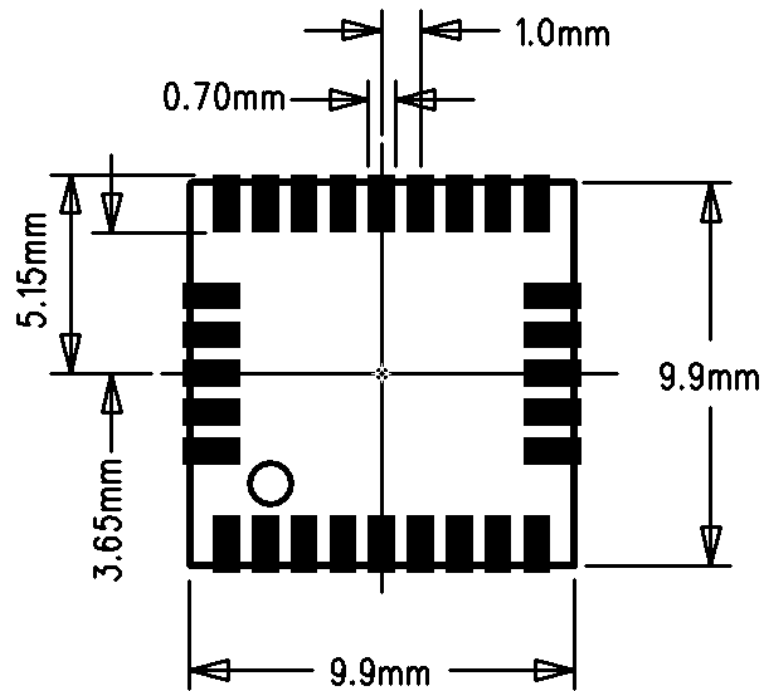

Figure 7 Suggested pad layout and occupied area, top view

5 Electrical Specifications

5.1 Absolute Maximum Ratings

Stressing the device beyond the Absolute Maximum Ratings may cause permanent damage. These are stress ratings only. Operation beyond the DC Electrical Specifications, Table 5 DC Electrical characteristics, is not recommended and extended exposure beyond the Recommended Operating Conditions can affect device reliability.

Table 4 Absolute Maximum Ratings

Symbol	Parameter	Min	Max	Unit
T_{AMB}	Operating and storage temperature	-40	+85	°C
P_{DIS}	Power dissipation	-	200	mW
VDD	Supply voltage input	-0.3	+2.2	V
V_{IO}	Input voltage on any input connection	-0.3	+3.6	V
$V_{IO(ESD)}$	IO ESD voltage (only RF_IN, Machine Model)	-50	+50	V
$V_{IO(ESD)}$	IO ESD voltage (excluding RF_IN, HBM model)	-2000	+2000	V
P_{RF}	RF_IN input power (in band 1575 +/- 30 MHz)	-	+10	dBm
P_{RF}	RF_IN input power (out of band <1460 MHz or >1710 MHz)	-	+15	dBm

Note that module is Electrostatic Sensitive Device (ESD).



5.2 DC Electrical specifications

Operating conditions are $T_{AMB} = +25^{\circ}\text{C}$ and $V_{DD} = +1.8\text{ V}$ unless stated otherwise.

Table 5 DC Electrical characteristics

Symbol	Parameter	Min	Typ	Max	Unit
T_{AMB}	Operating Temperature (<i>note 1</i>)	-40	+25	+85	°C
VDD	Supply voltage input	+1.71	+1.8	+1.89	V
V_{DDAC}	Supply voltage ripple, AC coupled			54	mV(RMS) f=0...3 MHz
V_{DDAC}	Supply voltage ripple, AC coupled			15	mV(RMS) f> 3 MHz
I_{VDD} (peak)	Supply current, peak acq.		47	90	mA
I_{VDD} (ave)	Supply current average, tracking		37		mA
I_{VDD} (Hib.)	Supply current, Hibernate state		20		µA
$I_{I(LEAK)}$	Leakage current, Digital Input	-10		+10	µA
V_{OL}	Low level output voltage, I_{OL} 2 mA			+0.4	V
V_{OH}	High level output voltage, I_{OH} 2 mA	0.75*VDD			V
V_{IL}	Low level input voltage	-0.3		+0.45	V
V_{IH}	High level input voltage	0.7*VDD		+3.6	V

Note 1: Operation in the temperature range -40°C ... -30°C is allowed but Time-to-First-Fix performance and tracking sensitivity may be degraded.

NOTE

Note that IT430 module is sensitive to supply voltage ripple caused by e.g. current drain variation and thus power supply should have effective series resistance (ESR) below 0.2 ohm.

5.3 AC Electrical characteristics

Operating conditions are $T_{\text{AMB}} = +25^{\circ}\text{C}$ and $V_{\text{DD}} = +1.8\text{ V}$ unless stated otherwise.

Table 6 AC Electrical characteristics

Symbol	Parameter	Min	Typ	Max	Unit
t_{TM}	TM (PPS) cycle time		1		s
$t_{\text{TM,H}}$	TM, high state pulse duration		200		ms
Δt_{PPS}	TM accuracy, rising edge (<i>note 1</i>)	-1		+1	μs
f_{RTC}	RTC output frequency (<i>note 2</i>)		32768		Hz

Note 1: with nominal GPS signal levels -130dBm .

Note 2: when enabled by I/O configuration.

6 Manufacturing

6.1 Assembly and Soldering

The IT430 module is intended for SMT assembly and soldering in a Pb-free reflow process on the top side of the PCB. Suggested solder paste stencil height is 150um minimum to ensure sufficient solder volume. If required paste mask pad openings can be increased to ensure proper soldering and solder wetting over pads.

Use pre-heating at 150... 180 °C for 60... 120 sec. Suggested peak reflow temperature is 235... 245°C (for SnAg3.0Cu0.5 alloy). Absolute max reflow temperature is 260°C. For details see Fastrax document 'Soldering Profile' ref (7).

Note that module is Electrostatic Sensitive Device (ESD). Rated voltage is TBD max (Machine Model) at RF_IN signal.

NOTE

Note that module is Electrostatic Sensitive Device (ESD), rating 50 V max (Machine Model) at RF_IN.



Avoid also ultrasonic exposure due to internal crystal and SAW components.

The IT430 module meets the requirements of Directive 2002/95/EC of the European Parliament and of the Council on the Restriction of Hazardous Substance (RoHS). For details contact Fastrax support.

6.2 Moisture sensitivity

IT430 module is moisture sensitive at MSL 3 (see the standard IPC/JEDEC J-STD-020C). The module must be stored in the original moisture barrier bag or if the bag is opened, the module must be repacked or stored in a dry cabin (according to the standard IPC/JEDEC J-STD-033B). Factory floor life in humid conditions is 1 week for MSL 3.

Moisture barrier bag self life is 1 year; thus it is suggested to assemble modules prior self life expiration. If the moisture barrier bag self life is exceeded, the modules must be baked prior usage; contact Fastrax support for details.

6.3 Marking

Module marking includes type code, batch code and serial number.

Type code is e.g. **IT430rbbbb** (may vary), where

- **IT430** is module type code for IT430
- **r** is incremental firmware revision (e.g. **C** = Signature firmware rev. 4.1.0 aka ROM2.0, may vary)
- **bbbb** is BOM (Bill-of-Materials) revision code (e.g. **4077**, may vary)

Batch code is e.g. **100208** (may vary), where

- **1** is factory code

- **0** is last digit of the year (e.g. 2010)
- **02** is month (e.g. February)
- **08** is incremental number of the production batch during the month

Serial number is unique for each module having 10 digits including tester code, last two digits of the year, Julian date code and incremental number.

6.3.1 Module firmware features

The IT430 module supports full Signature firmware feature set. Supported features include (ROM2.0 onwards):

- CW Jammer Remover
- Embedded Client and Server generated EE support
- TricklePower, and Push-to-Fix low power modes
- SiRFAware (aka Micro Power Management) 125 uA low power state for fastest TTFF
- Support for Almanac Based Navigation
- 5 Hz navigation
- AGPS support (Init aiding, set ephemeris, CGEE and SGEE support)
- SBAS/WAAS support (requires a patch with ROM2.0)
- MEMS sensor support: 3-D Accelerometer, 3-D Compass
- HW support for both LDO and switcher power mode

6.4 Tape and reel

Minimum order quantity is 500 pcs. Reel is packed in 500 pcs per reel.

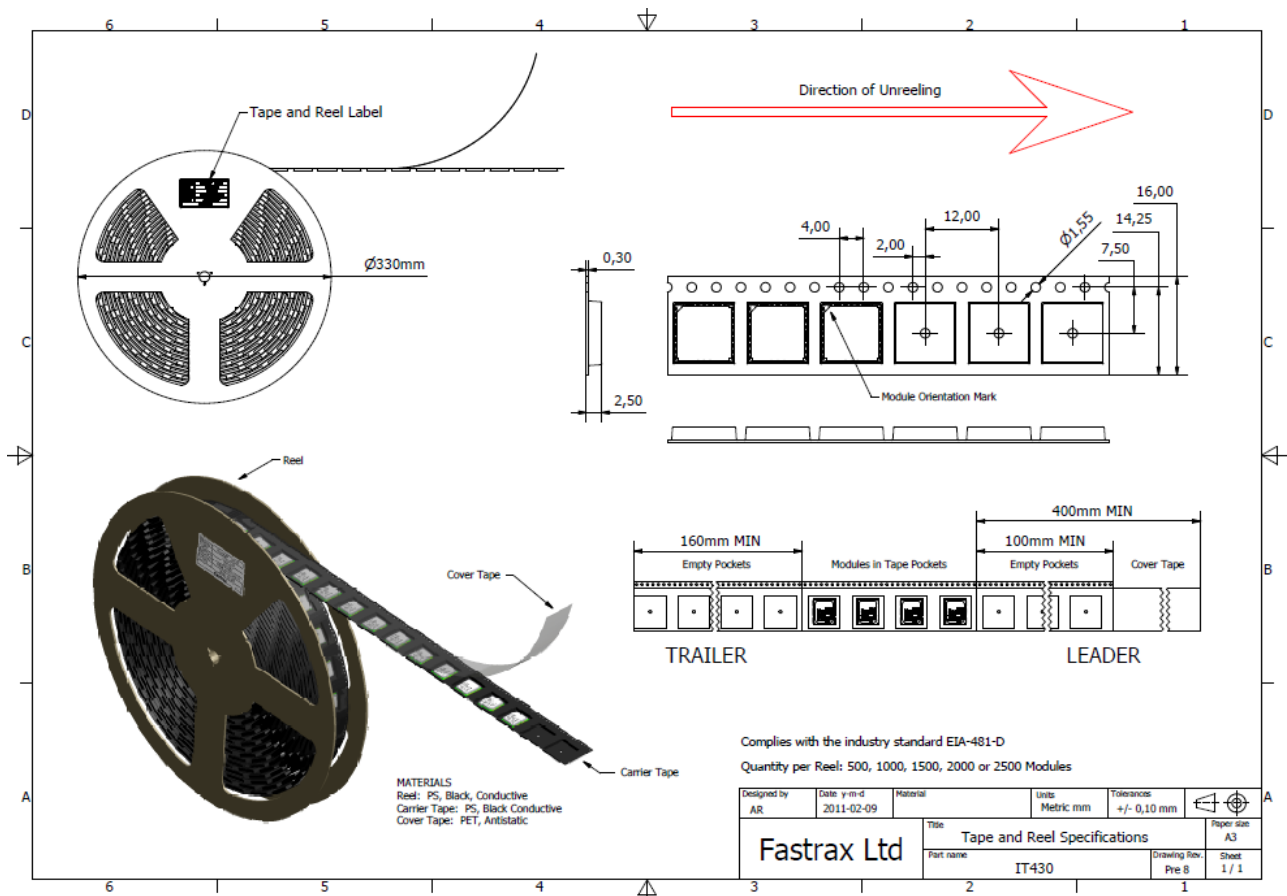

Figure 8 Tape and reel specification

6.5 Environmental Specification

The IT430 module is qualified for environmental stresses with the following test series:

Table 7 Environmental tests

Test	Condition	Standard
Temperature Cycle	Test: +85°C (20min) / -40°C (20min), Ramp Slope: 10°C/min, Test Cycles: 300 Cycles	JESD22A104
High Temperature Storage	Temperature +85°C , Test Time: 1,000hr	JESD22A103C
Temperature Humidity Test	Temperature +85°C , 85% R.H., Test Time: 1,000hr	JESD22A101
Vibration Test	10G, 10... 1,000Hz, 1 Octave/min (amplitude 1.0mm max @ <70Hz)	JESD22B103
Shock Test	100G pulse, duration 2ms, 5 Shock 2 directions 3 Axis = 30 Shocks	JESD22B110

7 Reference design

The idea of the reference design is to give a guideline for the applications using the OEM GPS module. In itself it is not a finished product, but an example that performs correctly.

In the following two chapters the reader is exposed to design rules that he should follow, when designing the GPS receiver in to the application. By following the rules one end up having an optimal design with no unexpected behavior caused by the PCB layout itself. In fact these guidelines are quite general in nature, and can be utilized in any PCB design related to RF techniques or to high speed logic.

7.1 Reference circuit diagram

The following picture describes a minimum connectivity for a typical autonomous navigation application. It consists of the IT430 module, which is powered by the main VDD supply (+1.8 V). The external by-pass capacitor C1 is used to de-couple the VDD supply pin.

No back up supply is required. Instead keep the main supply VDD active all the time and use the ON_OFF control input to switch between Navigation and Hibernate operation modes. WAKEUP signal can be used for external regulator mode control for full power state. WAKEUP signal can be also used to drive external antenna bias VDD_ANT (+3.3 V typ.) voltage switch (Q1) during Normal/Hibernate modes. L1 and C2 provide Additional RF decoupling to VDD_ANT supply.

The host port is configured to UART by the pull up resistor R5. Serial port TX output is connected to host UART input. RX input connection to host UART output is required when sending commands to IT430. ON_OFF input must be driven by the host to wake up the module from Hibernate state after first power up. Optional connectivity for host includes TM signal for timing purposes and ECLK signal (Message_Waiting, active high) in SPI and UART handshaking host port modes.

Optional connectivity includes an accelerometer sensor, a magnetometer sensor and an EEPROM on DR_I²C bus for stationary detection and for Extended Ephemeris or ROM patch code data storage, respectively. Use external pull up resistors 2.2kohm at bus signals when bus is used. Note that magnetometer and antenna bias supply may require also a 3.3V supply input.

Note that all I/O signal levels are CMOS 1.8V compatible and inputs are 3.6 V tolerable.

Some I/O signals have series resistors 47... 220 ohm, which are intended for RF-decoupling purposes to improve rejection to internally generated EMI that may leak to nearby GPS antenna. If GPS antenna is away > 20cm from module and/or I/O signals are routed under ground plane these series resistor may be omitted.

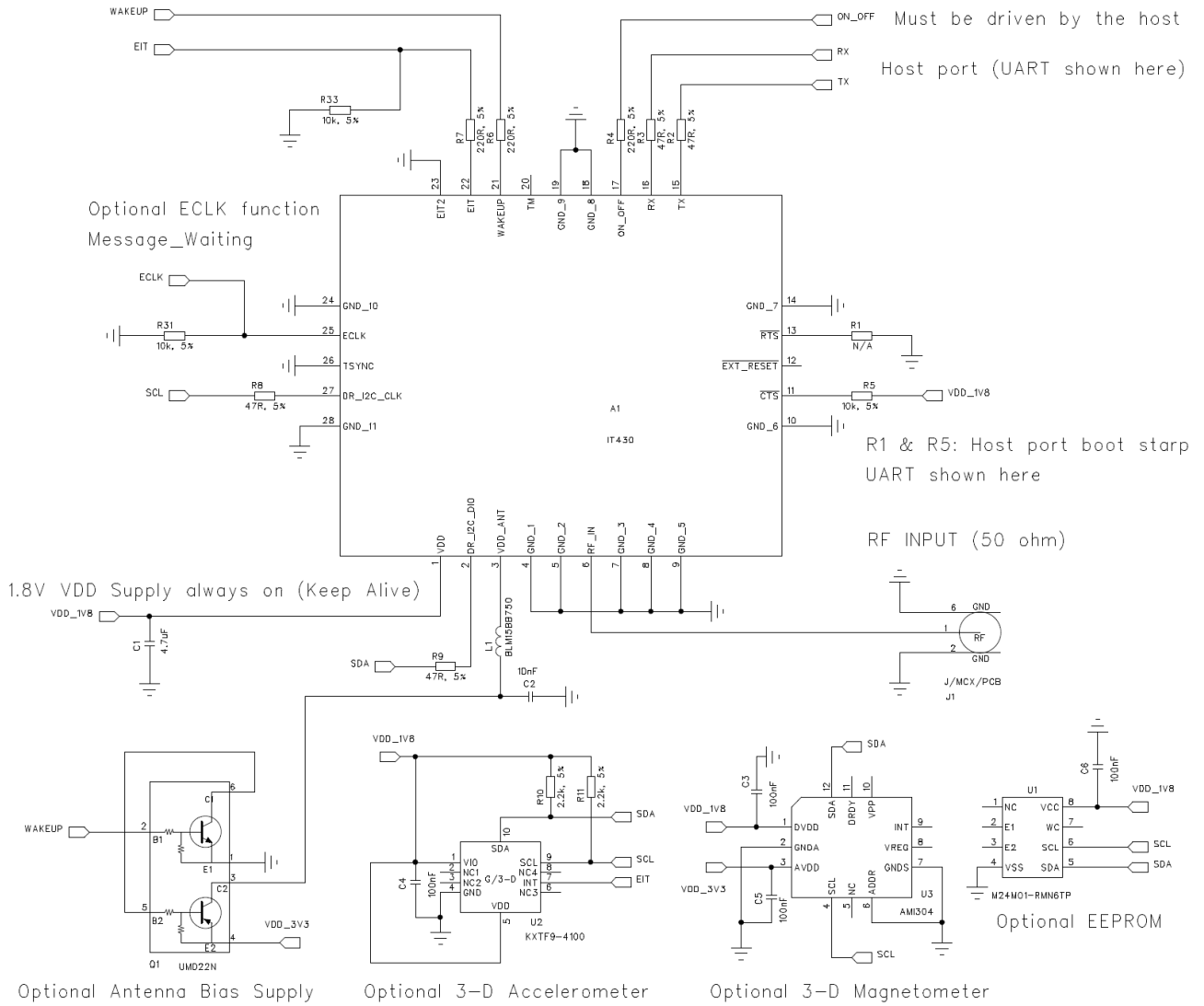

Figure 9 Reference circuit diagram

7.2 PCB layout suggestion

The suggested 4-layer PCB build up is presented in the following table.

Table 8 Suggested PCB build up

Layer	Description
1	Signal + RF trace + Ground plane with solid copper under IT430
2	Ground plane for signals and for RF trace
3	Signals and power planes
4	Ground plane (also short traces allowed)

For a multi-layer PCB the first inner layer below the IT430 is suggested to be dedicated for the ground plane. Below this ground layer other layers with signal traces are allowed. It is always better to route very long signal

traces in the inner layers of the PCB. In this way the trace can be easily shielded with ground areas from above and below.

The serial resistors at the I/O should be placed very near to the IT430 module. In this way the risk for the local oscillator leakage is minimized. For the same reason by-pass capacitors C1 and C2 should be connected very close to the module with short traces to IO contacts and to the ground plane. Place the GND via hole as close as possible to the capacitor.

Connect the GND soldering pads of the IT430 to ground plane with short traces (thermals) to via holes, which are connected to the ground plane. Use preferably one via hole for each GND pad.

The RF input should be routed clearly away from other signals, this minimizes the risk against interference. The proper width for the 50 ohm transmission line impedance depends on the dielectric material of the substrate and on the height between the signal trace and the first ground plane. With FR-4 material the width of the trace shall be two times the substrate height.

A board space free of any traces should be covered with copper areas (GND). In this way, a solid RF ground is achieved throughout the circuit board. Several via holes should be used to connect the ground areas between different layers.

Additionally, it is important that the PCB build-up is symmetrical on both sides of the PCB core. This can be achieved by choosing identical copper content on each layers, and adding copper areas to route-free areas. If the circuit board is heavily asymmetric, the board may bend during the PCB manufacturing or reflow soldering. Bending may cause soldering failures and reduce end product reliability.

The AP430 Application Board layout described in next chapter can be also used as layout reference.

7.2.1 Other electronics on mother board

Signal traces on top and bottom layers should have minimum length. Route signals mainly at inner layers below the top or bottom ground plane. In this way, a solid RF ground is achieved throughout the circuit board on top and bottom sides. Several via holes should be used to connect the ground areas between different layers.

Areas with dense component placing and dense routing requirements should be covered with a metal shield, which should be connected to ground plane with multiple GND via holes. Small ground plane openings for SMT components (length few mm, like LED or push buttons) in the ground plane are OK without a shield.

Dense areas having multiple via holes may open the ground plane for wide areas, thus blind and buried via holes are suggested to be used when changing layers for internal signals and power planes.

Use a power plane layer dedicated solely for power nets. Use wide trace width or even copper plane areas to achieve low impedance for power nets. Dedicate at least one layer as ground planes on adjacent layer above or below power plane layer in order to maximize capacitance to ground plane.

7.2.2 Avoiding EMI

Any GPS receiver is vulnerable to external spurious EMI signals since GPS signals are very weak below thermal noise floor. Any man made noise or spurious signals picked up by the nearby GPS antenna increases the noise floor and reduces GPS signal levels. Carrier Wave (CW) type spurious signals like clock harmonics on GPS band may also cause cross correlation products that may interfere with GPS signal tracking.

Since the ground plane of the mother board plays a vital role in the embedded antenna operation, it is essential for good GPS performance that the following measures against EMI are properly implemented:

- High speed electronics like host CPU & memory bus are enclosed in a 'Faraday shield'. The electrical enclosure is formed by the ground planes on PCB + metal shield over components. Route signals at inner layers as discussed previously. Use preferably a power plane(s) layer for supply nets.
- Any signal that is routed outside the Faraday shield is protected against EMI noise on 1575MHz with a serial RF filter like
 - a serial resistor (> 330ohm, suitable for I/O with low current) or
 - with a dedicated EMI filter (or ferrite bead) suitable for higher current or
 - with suitable by-pass capacitor e.g. 18pF (low impedance due to series resonance at 1575MHz).

The following picture gives a suggestion for e.g. a 6-layer PCB build up, which forms a Faraday shield together with ground planes on PCB and with the shield over high speed electronics. Buried and blind via holes are used to keep EMI signal inside ground planes. I/O signals that are routed outside the Faraday enclosure are filtered with a suitable EMI filter. Power plane layer is used for supply nets with low impedance traces/planes.

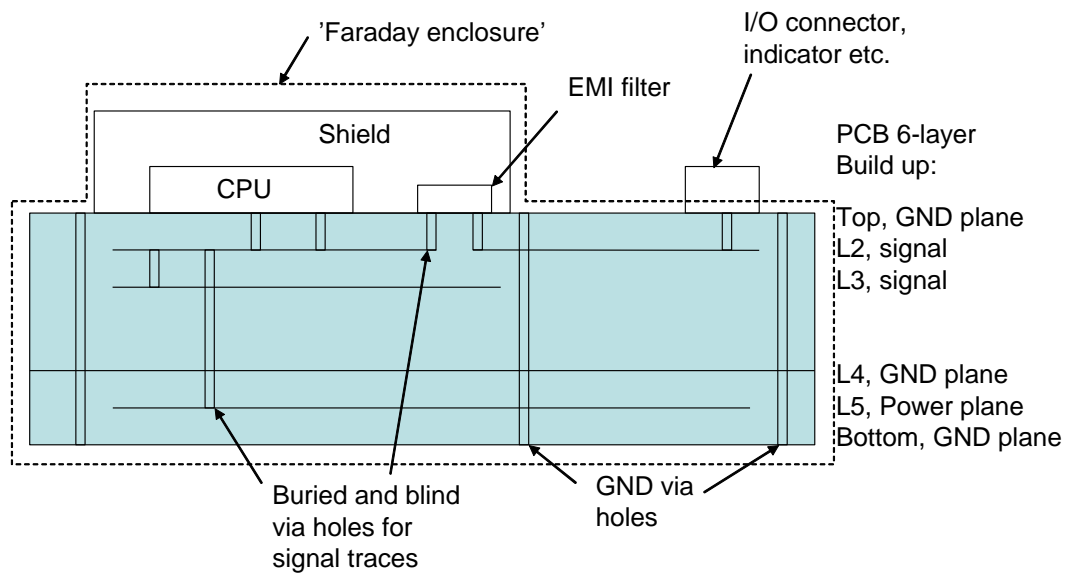

Figure 10 Avoiding EMI with Faraday enclosure

8 AP430 Application board for IT430

The Fastrax Application Board AP430 provides the IT430 connectivity to the Fastrax Evaluation Kit or to other evaluation purposes. It provides a single PCB board equipped with the IT430 module, 1.8V regulator, 1 Mbit EEPROM, MEMS accelerometer, 4 channel level translator for 1.8V I/O to 3.3V conversion, MCX antenna connector, Antenna Bias +3.3 V switch, Push-Button for ON_OFF control and 2x20 pin Card Terminal connector.

Default host port configuration is set to UART by switch S4... S8. Also connectivity to SPI and I2C host ports are supported via J3, see the circuit diagram for applicable switch settings, see chapter 0.

NOTE

Note that IT430 module is sensitive to supply voltage ripple and thus current measurement instrument connected at J4 should have internal series resistance below 0.2 ohm; e.g. use 10A range in the instrument.

8.1 Board Terminal I/O-connector

The following signals are available at the 40-pin Card Terminal I/O connector J2. The same pin numbering applies also to the Fastrax Evaluation Kit pin header J4. Note that UART Port maps to serial Port 0 at the Fastrax Evaluation Kit. I/O signal levels are CMOS 3.3V compatible unless stated otherwise.

Table 9 Board Terminal signals

Pin	Signal	I/O	Alternative name	GPIO	Interface to Fastrax Evaluation Kit
1	-	-	-		Not connected
2	GND	-	-		Ground
3	-	-	-		Not connected
4	GND	-	-		Ground
5	TX_3V3	O	TX		UART async. Output, VDD +3.3V
6	GND	-	-		Ground
7	RX	I	-		UART async. input
8	GND	-	-		Ground
9	VDD_3V3	I	-		Power supply input +3.3V
10	GND	-	-		Ground
11	TM_3V3	O	TM		1PPS signal output, VDD +3.3V
12	GND	-	-		Ground
13	XRESET_3V3	I	RESET_N		Active low async. system reset
14	-	-	-		Not connected
15	-	-	-		Not connected
16	-	I	-		Not connected
17	GND	-	-		Ground
18	-	-	-		Not connected
19	-	-	-		Not connected
20	-	-	-		Not connected
21	GND	-	-		Ground
22	-	-	-		Not connected
23	-	-	-		Not connected
24	-	-	-		Not connected
25	GND	-	-		Ground
26	-	-	-		Not connected

Pin	Signal	I/O	Alternative GPIO name	Interface to Fastrax Evaluation Kit
27	CTS	I	GPIO6	UART CTS signal
28	-	-	-	Not connected
29	RTS	O	GPIO7	UART RTS signal
30	UI_A_3V3	O	WAKEUP	UI indicator A output, VDD +3.3V
31	GND	-	-	Ground
32	EIT2	I	-	Interrupt EIT2
33	GND	-	-	Ground
34	EIT	I	-	Interrupt EIT
35	GND	-	-	Ground
36	TSYNC	I	-	Timesync timing input
37	GND	-	-	Ground
38	ECLK	I/O	GPIO3	ECLK clock input (or Message_Waiting output in SPI or UART handshaking host port modes)
39	GND	-	-	Ground
40	ON_OFF_N	I	ON_OFF (inv.)	Inverted ON_OFF control input, pulled up to VDD_3V3

8.2 Bill of materials

DESIGNATOR	TECHNICALDESCRIPTION	VALUE
A1	IT430 MODULE	IT430
C1	4,7uF 6,3V X5R 0805 +-20%	4u7F
C2	10nF 50V 10% X7R 0402	10nF
C3	Capacitor chip, 100nF 6.3V +-20% X5R 0402	100nF
C4	4,7uF 6,3V X5R 0805 +-20%	4u7F
C5	Capacitor chip, 27pF 50V 5% NP0 0402	27pF
C6	10nF 50V 10% X7R 0402	10nF
C7	4,7uF 6,3V X5R 0805 +-20%	4u7F
C8	10nF 50V 10% X7R 0402	10nF
C9	Capacitor chip, 100nF 6.3V +-20% X5R 0402	100nF
C10	Capacitor chip, 100nF 6.3V +-20% X5R 0402	100nF
C11	4,7uF 6,3V X5R 0805 +-20%	4u7F
C12	Capacitor chip, 1uF 6.3V +-20% X5R 0402	1uF
C13	Capacitor chip, 100nF 6.3V +-20% X5R 0402	100nF
C14	Capacitor chip, 100nF 6.3V +-20% X5R 0402	100nF
C15	Capacitor chip, 100nF 6.3V +-20% X5R 0402	100nF
C16	Capacitor chip, 100nF 6.3V +-20% X5R 0402	100nF
C17	Capacitor chip, 100nF 6.3V +-20% X5R 0402	100nF
C18	Capacitor chip, 10nF 16V 10% X7R 0402	10nF
C19	Capacitor chip, 470nF 6.3V +-10% X5R 0402	470nF
D1	LED GREEN	TLSU1008
J1	50 Ohm male MCX connector PCB	MCX_90DEG_PCB
J2	EDGE MOUNT SOCKET STRIP 40 PINS	2x20 edge
J3	2x5 pin-header, straight, 2.54mm	2x5P2.54
J4	1x2 pin-header, straight, pitch 2.54mm	1x2P2.54
L1	75R,+-25%@100MHz, 0R4@DC, 300mA	BLM15BB750
PCB1	Application board for IT430 rev C	PCB/AP430C00
Q1	Dual digital transistor, PNP/NPN	UMD22N
R1	Resistor chip, 15k 1% 0402 63mW	15k, 1%
R2	Resistor chip, 47R 0402 63mW 5%	47R, 5%
R3	Resistor chip, 47R 0402 63mW 5%	47R, 5%
R4	Resistor chip, 220R 5% 0402 63mW	220R, 5%
R5	Resistor chip, 47R 0402 63mW 5%	47R, 5%

R6	Resistor chip, 220R 5% 0402 63mW	220R, 5%
R7	Resistor chip, 220R 5% 0402 63mW	220R, 5%
R8	Resistor chip, 33k 1% 0402 63mW	33k 1%
R9	Resistor chip, 220R 5% 0402 63mW	220R, 5%
R10	Resistor chip, 220R 5% 0402 63mW	220R, 5%
R11	Resistor chip, 47R 0402 63mW 5%	47R, 5%
R12	Resistor chip, 47R 0402 63mW 5%	47R, 5%
R13	Resistor chip, 47R 0402 63mW 5%	47R, 5%
R14	Resistor chip, 0R 0402	N/A
R15	Resistor chip, 0R 0402	0R
R16	Resistor chip, 10k 5% 0402 63mW	10k, 5%
R17	Resistor chip, 10k 5% 0402 63mW	10k, 5%
R18	Resistor chip, 220R 5% 0402 63mW	220R, 5%
R19	Resistor chip, 47R 0402 63mW 5%	47R, 5%
R20	Resistor chip, 220R 5% 0402 63mW	220R, 5%
R21	Resistor chip, 220R 5% 0402 63mW	220R, 5%
R22	Resistor chip, 47R 0402 63mW 5%	47R, 5%
R24	Resistor chip, 47R 0402 63mW 5%	47R, 5%
R25	Resistor chip, 10k 5% 0402 63mW	10k, 5%
R26	Resistor chip, 10k 5% 0402 63mW	10k, 5%
R27	Resistor chip, 10k 5% 0402 63mW	10k, 5%
R28	Resistor chip, 2k2 5% 0402 63mW	2.2k, 5%
R29	Resistor chip, 2k2 5% 0402 63mW	2.2k, 5%
R30	Resistor chip, 10k 5% 0402 63mW	10k, 5%
R31	Resistor chip, 10k 5% 0402 63mW	10k, 5%
R32	Resistor chip, 10k 5% 0402 63mW	10k, 5%
R33	Resistor chip, 10k 5% 0402 63mW	N/A
R34	Resistor chip, 1.5k 5% 0402 63mW	N/A
R35	Resistor chip, 1.5k 5% 0402 63mW	N/A
S1	Jumper, Pitch, 2.54mm, Red colour	J4/P1-P2
S2	Label 13x16mm iTrax03s	STICKER13x16
S3	Switch, SMD PUSH BUTTON	SW
S4	Switch, on-off	SW JMP 2P54
S5	Switch, on-off	SW JMP 2P54
S6	Switch, on-off	SW JMP 2P54
S7	Switch, on-off	SW JMP 2P54
S8	Switch, on-off	SW JMP 2P54
U1	Sensor, 3D Magnetometer	AMI304
U2	Dual supply 4 bit translator	FXL4TD245
U3	REGULATOR TPS79101	TPS79101
U4	Schmit-Trigger inverter	NC7SZ14M5X
U5	EEPROM 1Mbit, 1.8-5.5V, I2C, SO8N	M24M01-RMN6TP
U6	Sensor, Barometer	
U7	Sensor, 3D Gyro	
U8	Sensor, 3D Accelerometer	KXTF9-4100

8.3 AP430 Circuit diagram

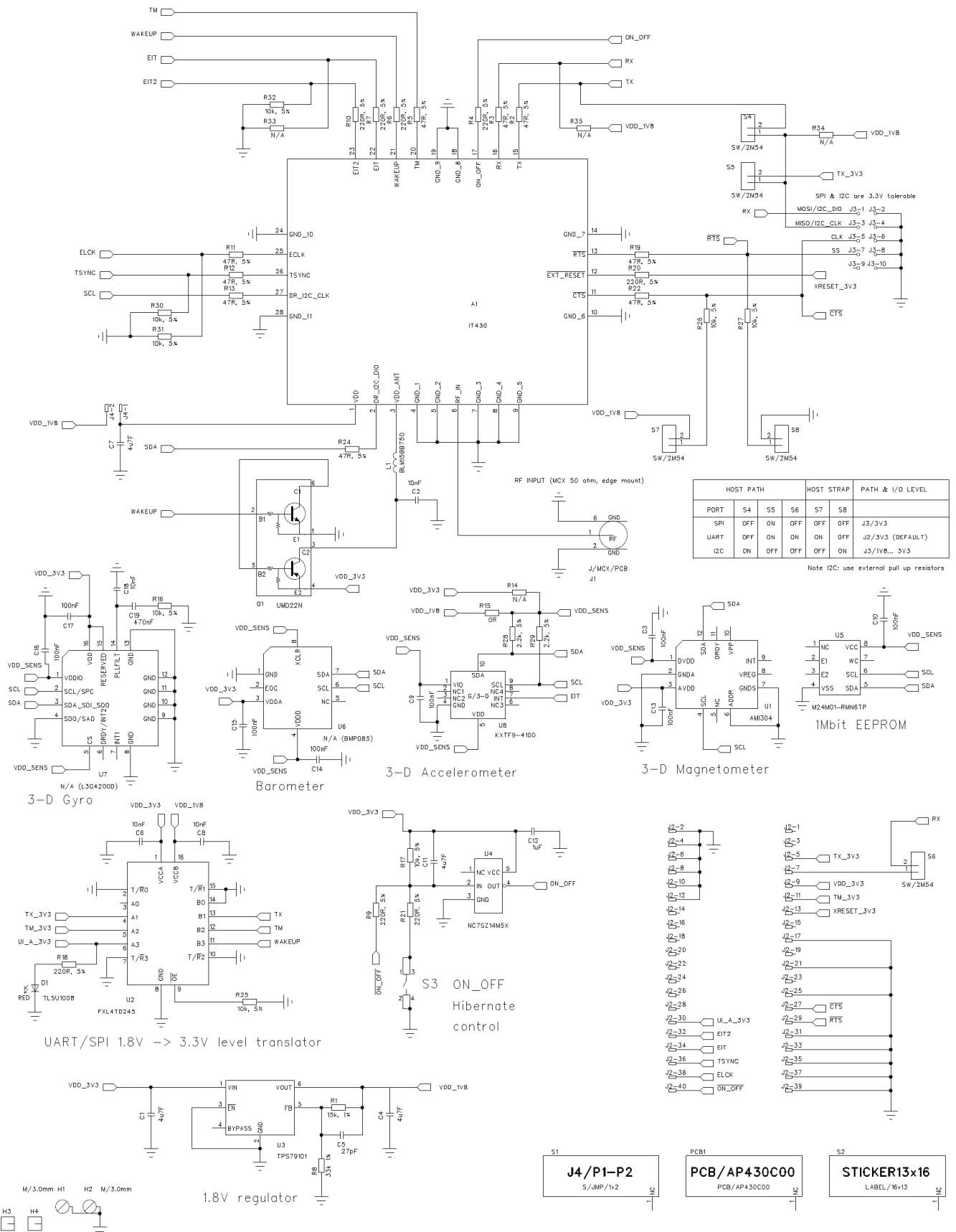

Figure 11 AP430 Circuit diagram

8.4 AP430 layout and assembly

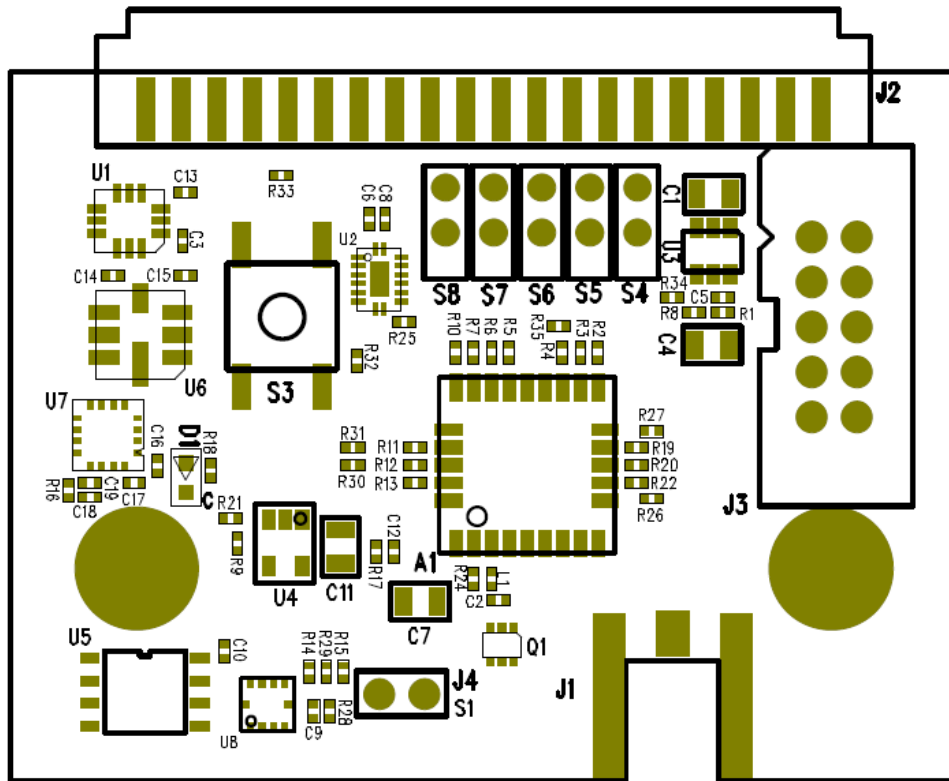

Figure 12 Assembly drawing, top side

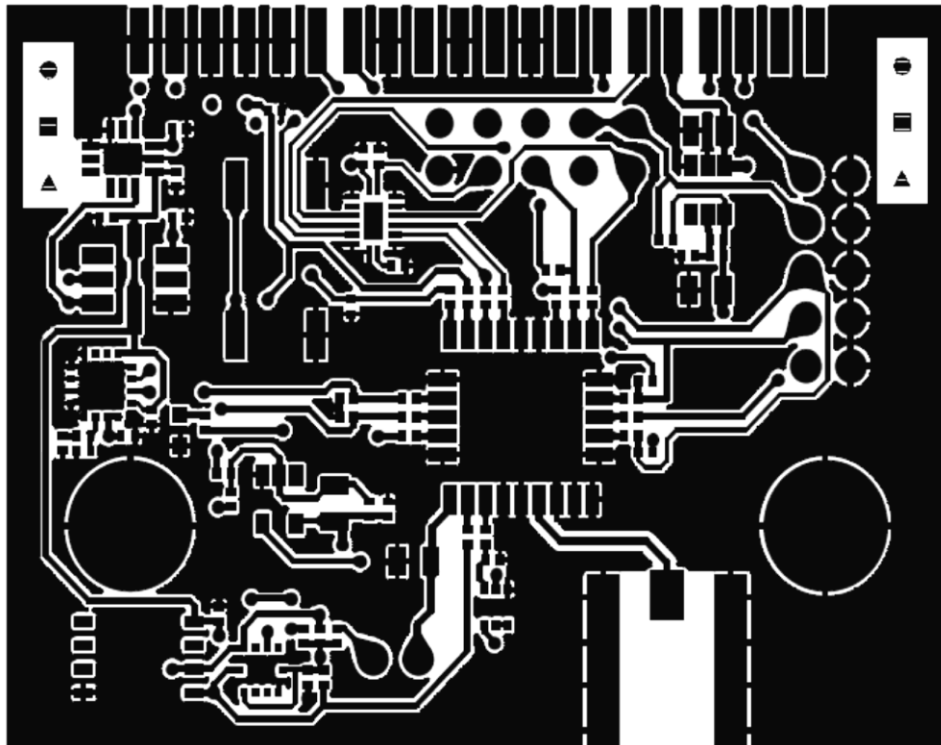

Figure 13 Layer 1, (top)

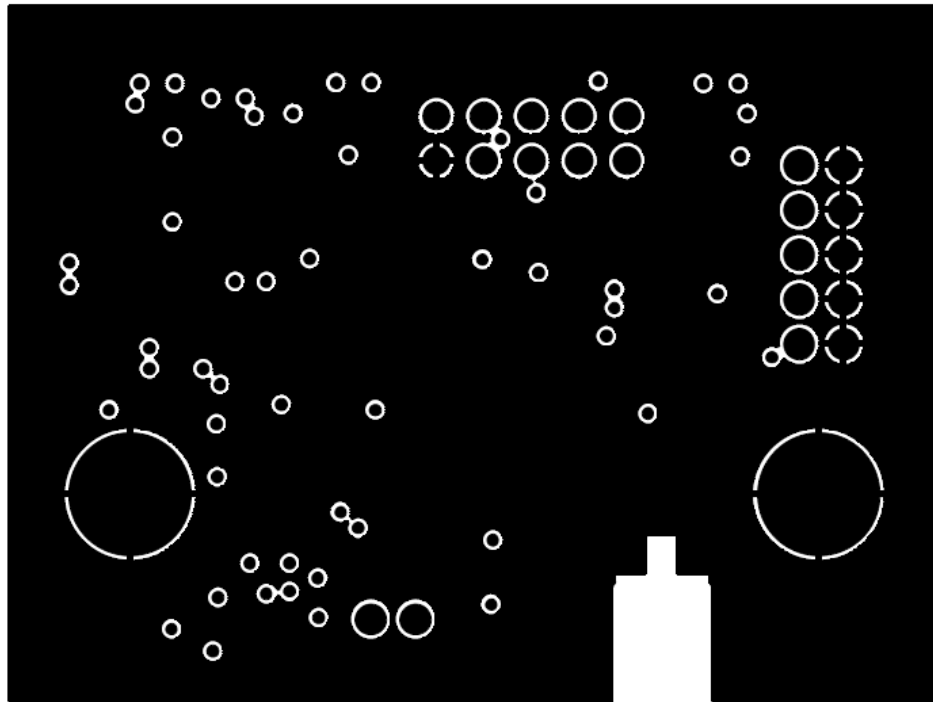

Figure 14 Layer 2

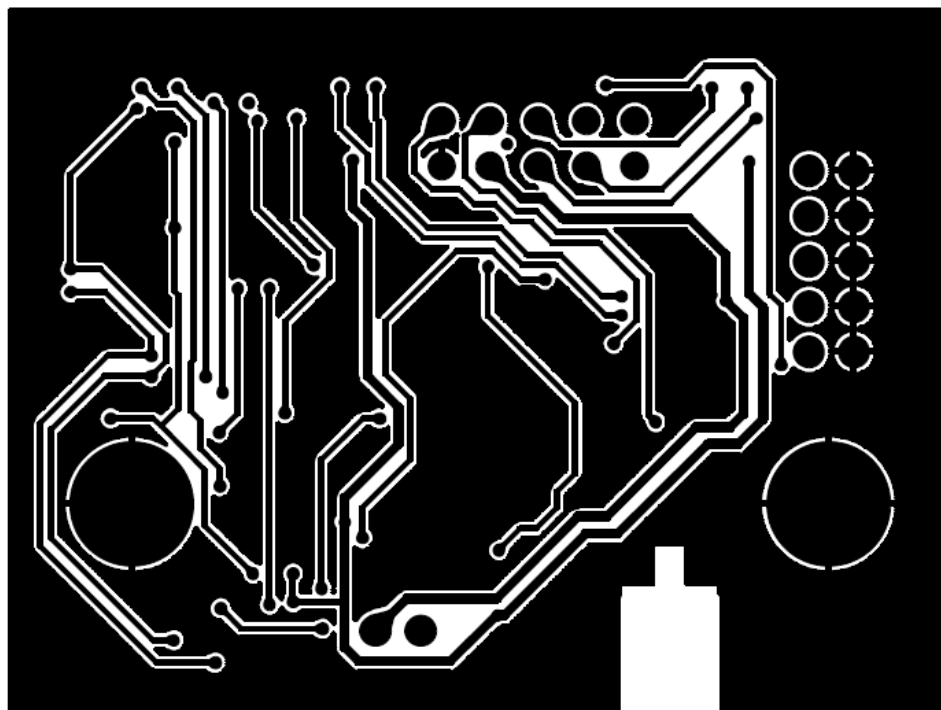

Figure 15 Layer 3

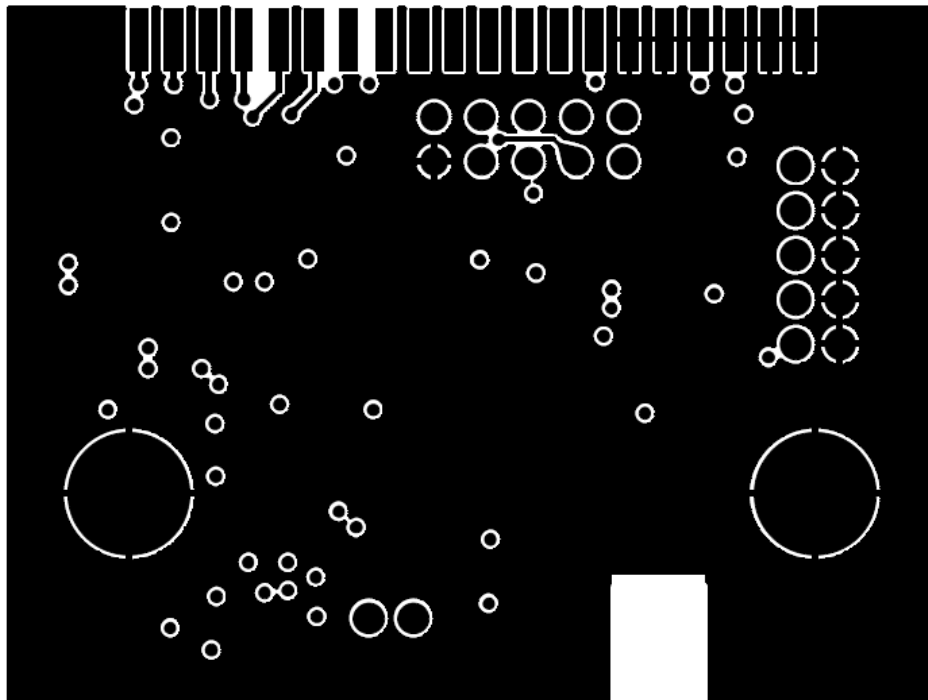

Figure 16 Layer 4 (bottom)

Contact Information

Fastrax Ltd

Street Address: Valimotie 7, 01510 Vantaa, FINLAND

Tel: +358 (0)424 733 1

Fax: +358 (0)9 8240 9691

<http://www.fastraxgps.com>

E-mail:

Sales: sales@fastraxgps.com

Support: support@fastraxgps.com