

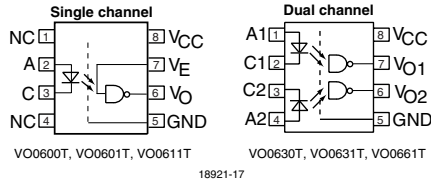

High Speed Optocoupler, 10 MBd, SOIC-8 Package

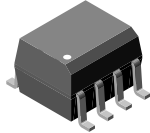

FEATURES

- Choice of CMR performance of 15 kV/μs, 5 kV/μs, and 100 V/μs
- High speed: 10 MBd typical
- + 5 V CMOS compatibility
- Pure tin leads
- Guaranteed AC and DC performance over temperature: - 40 °C to + 100 °C temp. range
- Meets IEC 60068-2-42 (SO₂) and IEC 60068-2-43 (H₂S) requirements
- Low input current capability: 5 mA
- Lead (Pb)-free component
- Component in accordance to RoHS 2002/95/EC and WEEE 2002/96/EC



RoHS
COMPLIANT

DESCRIPTION

The VO06xxT family are single and dual channel 10 MBd optocoupler utilizing a high efficient input LED coupled with an integrated optical photodiode IC detector. The detector has an open drain NMOS-transistor output, providing less leakage compared to an open collector Schottky clamped transistor output. For the single channel type, an enable function on pin 7 allows the detector to be strobed. The internal shield provides a guaranteed common mode transient immunity of 5 kV/μs for the VO0601T and VO0631T and 15 kV/μs for the VO0611T and VO0661T. The use of a 0.1 μF bypass capacitor connected between pin 5 and 8 is recommended.

AGENCY APPROVALS

- UL1577, file no. E52744
- CUL-file no. E52744, equivalent to CSA bulletin 5A
- DIN EN 60747-5-2 (VDE 0884) available with option 1

APPLICATIONS

- Microprocessor systemM interface
- PLC, ATE input/output isolation
- Computer peripheral interface: SPI
- Digital fieldbus isolation: CC-Link, DeviceNet, profibus, SDS
- High speed A/D and D/A conversion
- AC plasma display panel level shifting
- Multiplexed data transmission
- Digital control power supply
- Ground loop elimination

ORDER INFORMATION	
PART	REMARKS
VO0600T	100 V/μs, single channel, SOIC-8
VO0601T	5 kV/μs, single channel, SOIC-8
VO0611T	15 kV/μs, single channel, SOIC-8
VO0630T	100 V/μs, dual channel, SOIC-8
VO0631T	5 kV/μs, dual channel, SOIC-8
VO0661T	15 kV/μs, dual channel, SOIC-8

TRUTH TABLE (positive logic)	
LED	OUTPUT
ON	L
OFF	H

ABSOLUTE MAXIMUM RATINGS ⁽¹⁾				
PARAMETER	TEST CONDITION	SYMBOL	VALUE	UNIT
INPUT				
Average forward current (single channel)		I_F	20	mA
Average forward current (dual channel)		I_F	15	mA
Reverse input voltage		V_R	5	V
Enable input voltage (single channel)		V_E	$V_{CC} + 0.5 V$	V
Enable input current (single channel)		I_E	5	mA
Surge current	$t = 100 \mu s$	I_{FSM}	200	mA
Output power dissipation (single channel)		P_{diss}	35	mW
Output power dissipation (per channel for dual channel)		P_{diss}	25	mW
OUTPUT				
Supply voltage	1 min maximum	V_{CC}	7	V
Output current		I_O	50	mA
Output voltage		V_O	7	V
Output power dissipation (single channel)		P_{diss}	85	mW
Output power dissipation (per channel for dual channel)		P_{diss}	60	mW
COUPLER				
Isolation test voltage	$t = 1.0 s$	V_{ISO}	4000	V_{RMS}
Storage temperature		T_{stg}	- 55 to + 150	°C
Operating temperature		T_{amb}	- 40 to + 100	°C
Lead solder temperature	for 10 s		260	°C
Solder reflow temperature ⁽²⁾	for 1 min		260	°C

Notes

⁽¹⁾ $T_{amb} = 25 \text{ }^\circ\text{C}$, unless otherwise specified.

Stresses in excess of the absolute maximum ratings can cause permanent damage to the device. Functional operation of the device is not implied at these or any other conditions in excess of those given in the operational sections of this document. Exposure to absolute maximum ratings for extended periods of the time can adversely affect reliability.

⁽²⁾ Refer to reflow profile for soldering conditions for surface mounted devices.

RECOMMENDED OPERATING CONDITION						
PARAMETER	TEST CONDITION	SYMBOL	MIN.	TYP.	MAX.	UNIT
Operating temperature		T_{amb}	- 40		100	°C
Supply voltage		V_{CC}	4.5		5.5	V
Input current low level		I_{FL}	0		250	μA
Input current high level		I_{FH}	5		15	mA
Output pull up resistor		R_L	330		4K	Ω
Logic high enable voltage		V_{EH}	2.0		V_{CC}	V
Logic low enable voltage		V_{EL}	0.0		0.8	V
Fanout	$R_L = 1 \text{ k}\Omega$	N			5	-

ELECTRICAL CHARACTERISTICS						
PARAMETER	TEST CONDITION	SYMBOL	MIN.	TYP.	MAX.	UNIT
INPUT						
Input forward voltage	$I_F = 10 \text{ mA}$	V_F	1.1	1.4	1.7	V
Reverse current	$V_R = 5 \text{ V}$	I_R		0.01	10	μA
Input capacitance	$f = 1 \text{ MHz}, V_F = 0 \text{ V}$	C_I		55		pF



ELECTRICAL CHARACTERISTICS						
PARAMETER	TEST CONDITION	SYMBOL	MIN.	TYP.	MAX.	UNIT
OUTPUT						
High level supply current (single channel)	$V_E = 0.5\text{ V}, I_F = 0\text{ mA}$	I_{CCH}		4.1	7.0	mA
	$V_E = V_{CC}, I_F = 0\text{ mA}$	I_{CCH}		3.3	6.0	mA
High level supply current (dual channel)	$I_F = 10\text{ mA}$	I_{CCH}		6.5	12.0	mA
Low level supply current (single channel)	$V_E = 0.5\text{ V}, I_F = 10\text{ mA}$	I_{CCL}		4.0	7.0	mA
	$V_E = V_{CC}, I_F = 10\text{ mA}$	I_{CCL}		3.3	6.0	mA
Low level supply current (dual channel)	$I_F = 10\text{ mA}$	I_{CCL}		6.5	12.0	mA
High level output current	$V_E = 2.0\text{ V}, V_O = 5.5\text{ V}, I_F = 250\text{ }\mu\text{A}$	I_{OH}		0.002	1	μA
Low level output voltage	$V_E = 2.0\text{ V}, I_F = 5\text{ mA}, I_{OL}(\text{sinking}) = 13\text{ mA}$	V_{OL}		0.2	0.6	V
Input threshold current	$V_E = 2.0\text{ V}, V_O = 5.5\text{ V}, I_{OL}(\text{sinking}) = 13\text{ mA}$	I_{TH}		2.4	5.0	mA
High level enable current		I_{EH}		-0.6	-1.6	mA
Low level enable current		I_{EL}		-0.8	-1.6	mA
High level enable voltage		V_{EH}	2.0			V
Low level enable voltage		V_{EL}			0.8	V

Note

$T_{amb} = 25\text{ }^\circ\text{C}$, unless otherwise specified.

Minimum and maximum values are testing requirements. Typical values are characteristics of the device and are the result of engineering evaluation. Typical values are for information only and are not part of the testing requirements.

SWITCHING CHARACTERISTICS						
PARAMETER	TEST CONDITION	SYMBOL	MIN.	TYP.	MAX.	UNIT
Propagation delay time to high output level	$R_L = 350\text{ }\Omega, C_L = 15\text{ pF}$	t_{PLH}	20	48	100	ns
Propagation delay time to low output level	$R_L = 350\text{ }\Omega, C_L = 15\text{ pF}$	t_{PHL}	25	50	100	ns
Pulse width distortion	$R_L = 350\text{ }\Omega, C_L = 15\text{ pF}$	$ t_{PHL} - t_{PLH} $		2.9	35	ns
Propagation delay skew	$R_L = 350\text{ }\Omega, C_L = 15\text{ pF}$	t_{PSK}		8	40	ns
Output rise time (10 to 90 %)	$R_L = 350\text{ }\Omega, C_L = 15\text{ pF}$	t_r		23		ns
Output fall time (90 to 10 %)	$R_L = 350\text{ }\Omega, C_L = 15\text{ pF}$	t_f		7		ns
Propagation delay time of enable from V_{EH} to V_{EL}	$R_L = 350\text{ }\Omega, C_L = 15\text{ pF}, V_{EL} = 0\text{ V}, V_{EH} = 3\text{ V}$	t_{ELH}		12		ns
Propagation delay time of enable from V_{EL} to V_{EH}	$R_L = 350\text{ }\Omega, C_L = 15\text{ pF}, V_{EL} = 0\text{ V}, V_{EH} = 3\text{ V}$	t_{EHL}		11		ns

Note

Over recommended temperature ($T_A = -40\text{ }^\circ\text{C}$ to $+100\text{ }^\circ\text{C}$), $V_{CC} = 5\text{ V}, I_F = 7.5\text{ mA}$ unless otherwise specified.

All typicals at $T_A = 25\text{ }^\circ\text{C}, V_{CC} = 5\text{ V}$.

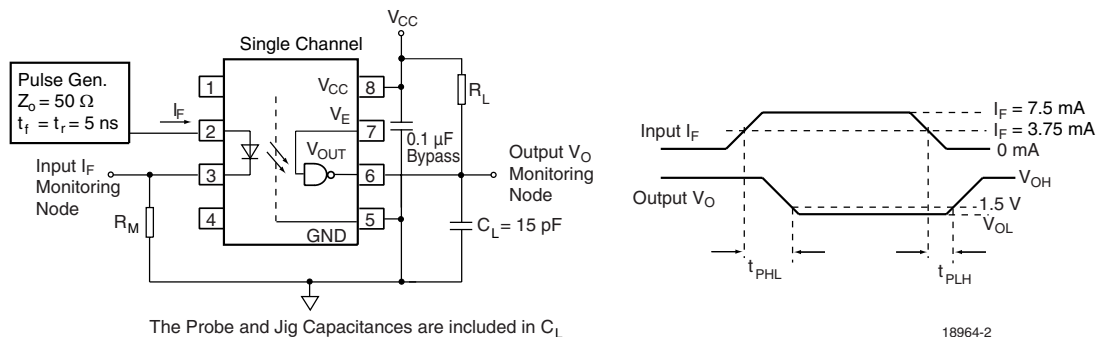

The Probe and Jig Capacitances are included in C_L

Fig. 1 - Single Channel Test Circuit for t_{PLH}, t_{PHL}, t_r and t_f

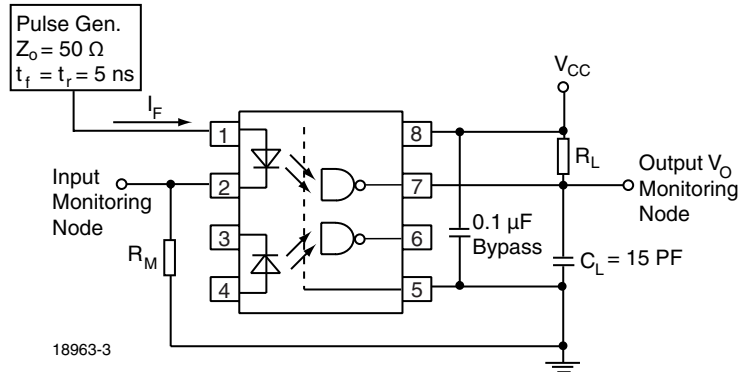
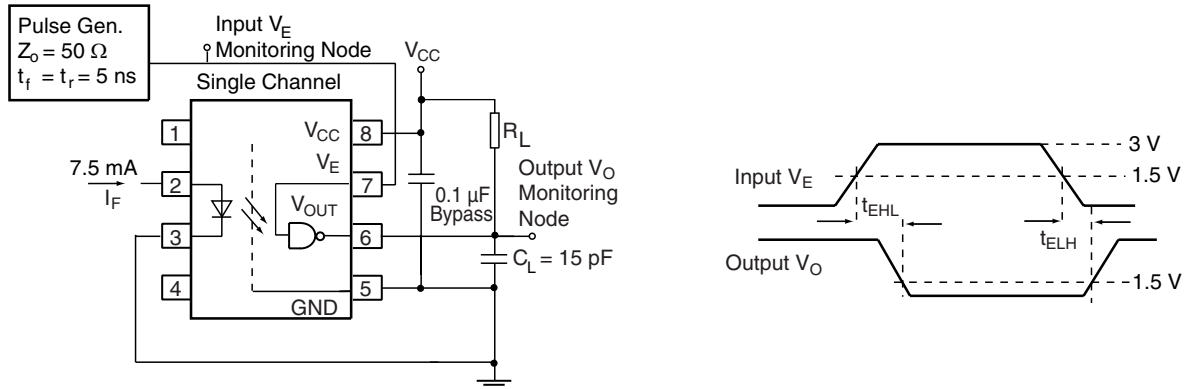

Fig. 2 - Dual Channel Test Circuit for t_{PLH} , t_{PHL} , t_f and t_r



The Probe and Jig Capacitances are included in C_L

Fig. 3 - Single Channel Test Circuit for t_{EHL} , t_{ELH}

COMMON MODE TRANSIENT IMMUNITY						
PARAMETER	TEST CONDITION	SYMBOL	MIN.	TYP.	MAX.	UNIT
Common mode transient immunity (high)	$ V_{CM} = 10 \text{ V}$, $V_{CC} = 5 \text{ V}$, $I_F = 0 \text{ mA}$, $V_{O(min)} = 2 \text{ V}$, $R_L = 350 \Omega$, $T_{amb} = 25 \text{ }^\circ\text{C}^{(1)}$	$ CM_H $	100			$\text{V}/\mu\text{s}$
	$ V_{CM} = 50 \text{ V}$, $V_{CC} = 5 \text{ V}$, $I_F = 0 \text{ mA}$, $V_{O(min)} = 2 \text{ V}$, $R_L = 350 \Omega$, $T_{amb} = 25 \text{ }^\circ\text{C}^{(2)}$	$ CM_H $	5000	10000		$\text{V}/\mu\text{s}$
	$ V_{CM} = 1 \text{ kV}$, $V_{CC} = 5 \text{ V}$, $I_F = 0 \text{ mA}$, $V_{O(min)} = 2 \text{ V}$, $R_L = 350 \Omega$, $T_{amb} = 25 \text{ }^\circ\text{C}^{(3)}$	$ CM_H $	15000	25000		$\text{V}/\mu\text{s}$
Common mode transient immunity (low)	$ V_{CM} = 10 \text{ V}$, $V_{CC} = 5 \text{ V}$, $I_F = 7.5 \text{ mA}$, $V_{O(max)} = 0.8 \text{ V}$, $R_L = 350 \Omega$, $T_{amb} = 25 \text{ }^\circ\text{C}^{(1)}$	$ CM_L $	100			$\text{V}/\mu\text{s}$
	$ V_{CM} = 50 \text{ V}$, $V_{CC} = 5 \text{ V}$, $I_F = 7.5 \text{ mA}$, $V_{O(max)} = 0.8 \text{ V}$, $R_L = 350 \Omega$, $T_{amb} = 25 \text{ }^\circ\text{C}^{(2)}$	$ CM_L $	5000	10000		$\text{V}/\mu\text{s}$
	$ V_{CM} = 1 \text{ kV}$, $V_{CC} = 5 \text{ V}$, $I_F = 7.5 \text{ mA}$, $V_{O(max)} = 0.8 \text{ V}$, $R_L = 350 \Omega$, $T_{amb} = 25 \text{ }^\circ\text{C}^{(3)}$	$ CM_L $	15000	25000		$\text{V}/\mu\text{s}$

Notes

- (1) For VO0600T and VO0630T
- (2) For VO0601T and VO0631T
- (3) For VO0611T and VO0661T

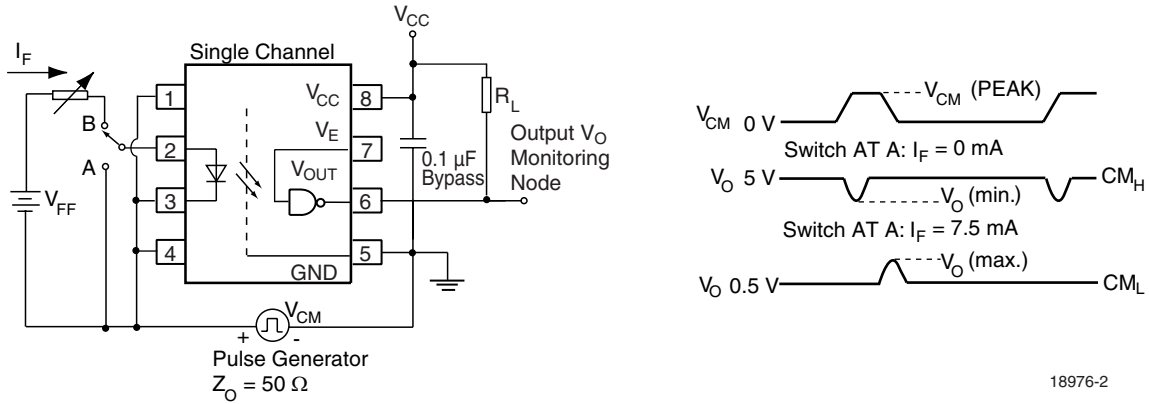

Fig. 4 - Single Channel Test Circuit for Common Mode Transient Immunity

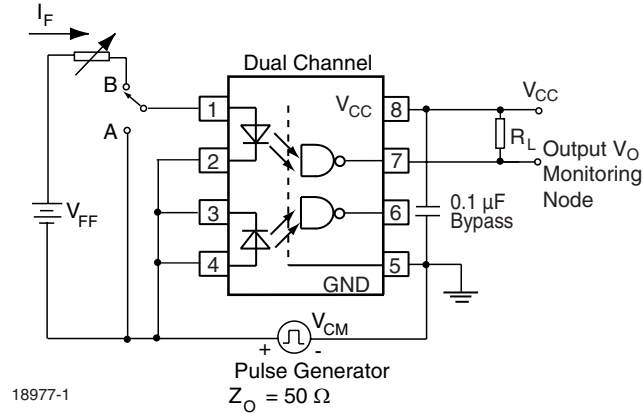

Fig. 5 - Dual Channel Test Circuit for Common Mode Transient Immunity

SAFETY AND INSULATION RATINGS						
PARAMETER	TEST CONDITION	SYMBOL	MIN.	TYP.	MAX.	UNIT
Climatic classification (according to IEC 68 part 1)				55/100/21		
Comparative tracking index		CTI	175		399	
V_{IOTM}			6000			V
V_{IORM}			560			V
P_{SO}					350	mW
I_{SI}					150	mA
T_{SI}					165	°C
Creepage			4			mm
Clearance			4			mm
Insulation thickness, reinforced rated	per IEC 60950 2.10.5.1		0.2			mm

Note

As per IEC 60747-5-2, 7.4.3.8.1, this optocoupler is suitable for “safe electrical insulation” only within the safety ratings. Compliance with the safety ratings shall be ensured by means of protective circuits.

TYPICAL CHARACTERISTICS

$T_{amb} = 25\text{ }^{\circ}\text{C}$, unless otherwise specified

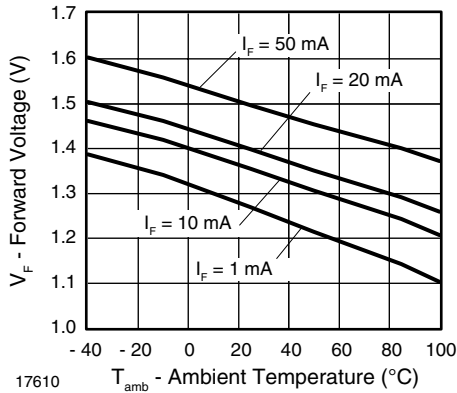

Fig. 6 - Forward Voltage vs. Ambient Temperature

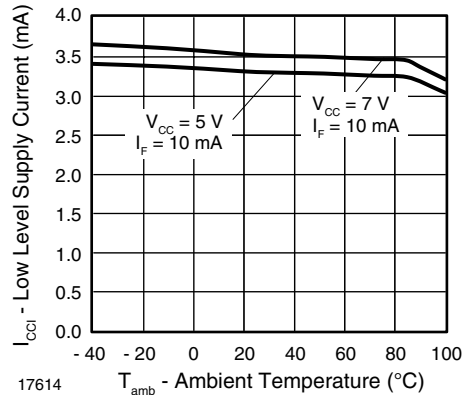

Fig. 9 - Low Level Supply Current vs. Ambient Temperature

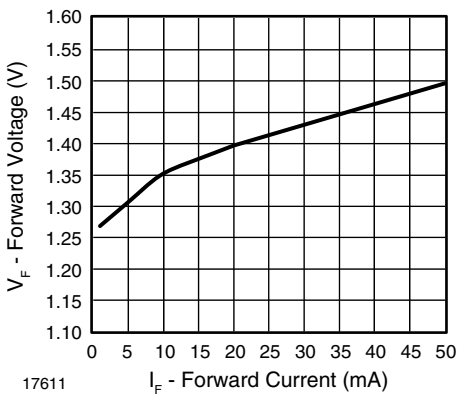

Fig. 7 - Forward Voltage vs. Forward Current

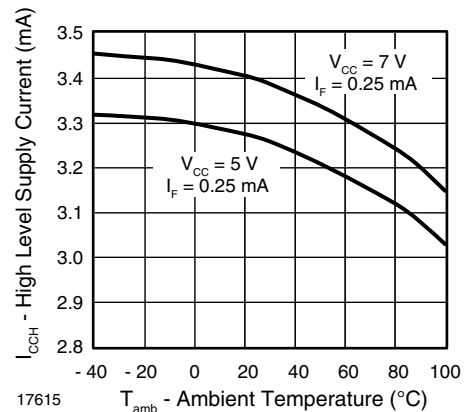

Fig. 10 - High Level Supply Current vs. Ambient Temperature

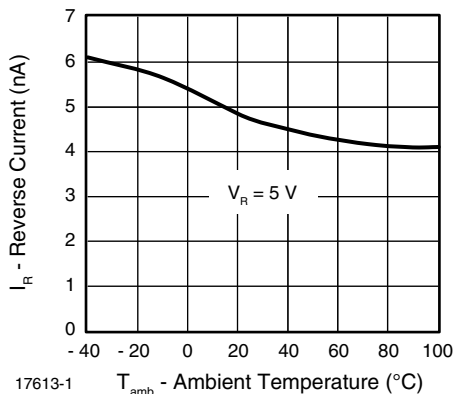

Fig. 8 - Reverse Current vs. Ambient Temperature

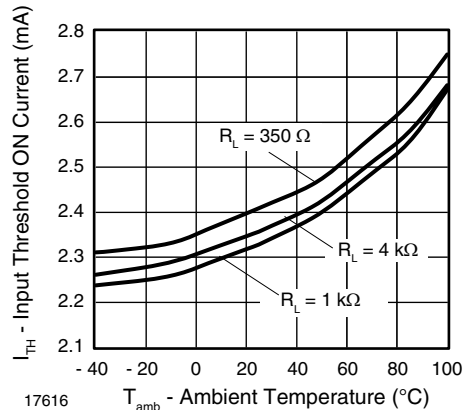

Fig. 11 - Input Threshold ON Current vs. Ambient Temperature



VO0600T/VO0601T/VO0611T/VO0630T/VO0631T/VO0661T

High Speed Optocoupler,
10 MBd, SOIC-8 Package

Vishay Semiconductors

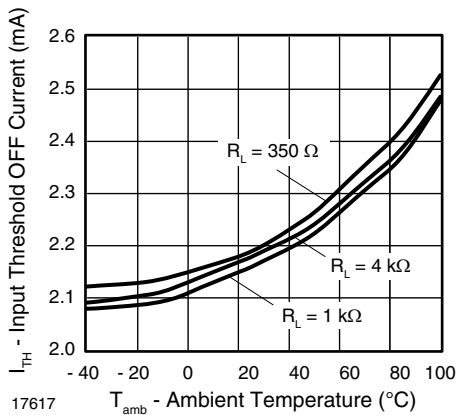

Fig. 12 - Input Threshold Off Current vs. Ambient Temperature

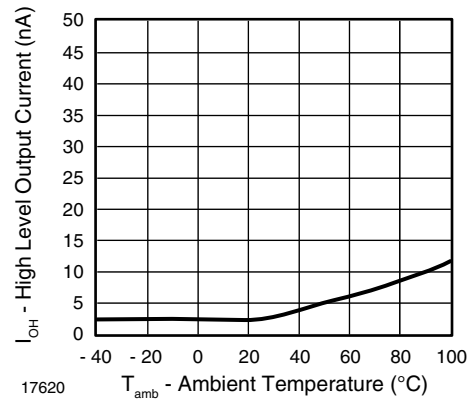

Fig. 15 - High Level Output Current vs. Ambient Temperature

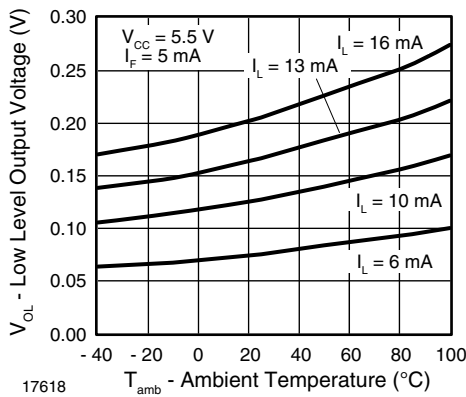

Fig. 13 - Low Level Output Voltage vs. Ambient Temperature

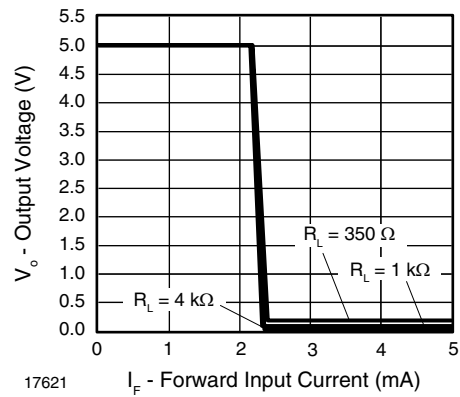

Fig. 16 - Output Voltage vs. Forward Input Current

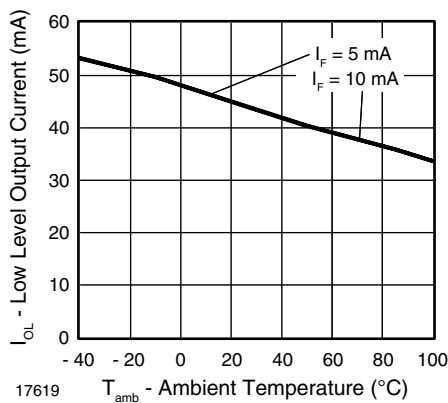

Fig. 14 - Low Level Output Current vs. Ambient Temperature

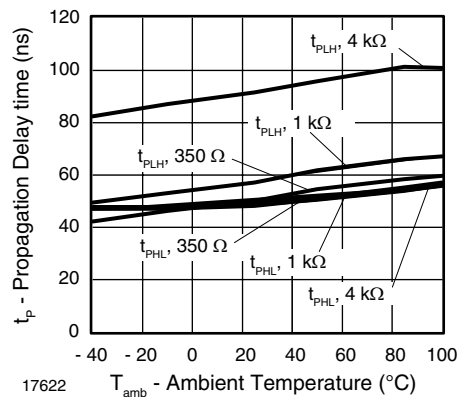

Fig. 17 - Propagation Delay vs. Ambient Temperature

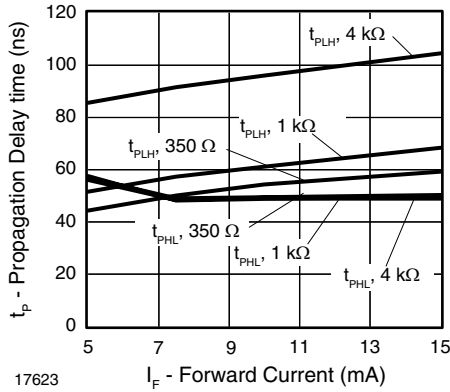

Fig. 18 - Propagation Delay vs. Forward Current

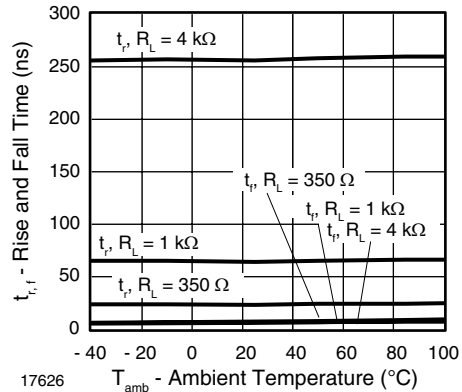

Fig. 21 - Rise and Fall Time vs. Ambient Temperature

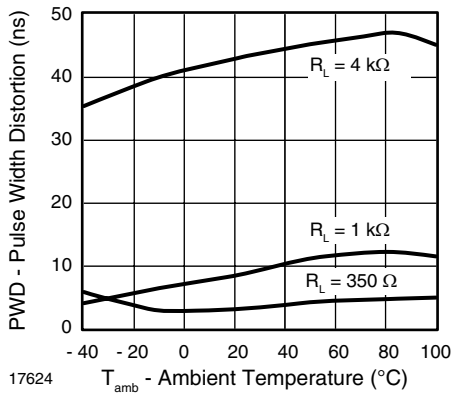

Fig. 19 - Pulse Width Distortion vs. Ambient Temperature

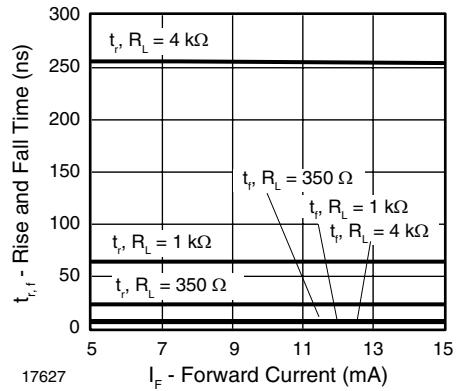

Fig. 22 - Rise and Fall Time vs. Forward Current

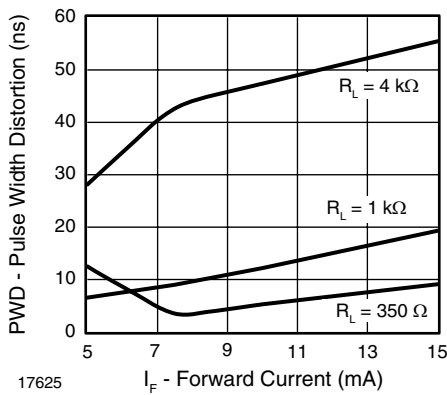

Fig. 20 - Pulse Width Distortion vs. Forward Current

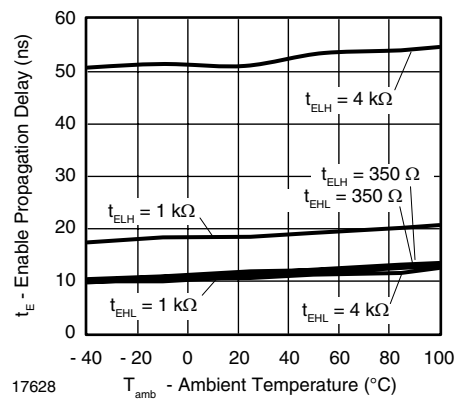

Fig. 23 - Enable Propagation Delay vs. Ambient Temperature



VO0600T/VO0601T/VO0611T/VO0630T/VO0631T/VO0661T

High Speed Optocoupler,
10 MBd, SOIC-8 Package

Vishay Semiconductors

PACKAGE DIMENSIONS in inches (millimeters)

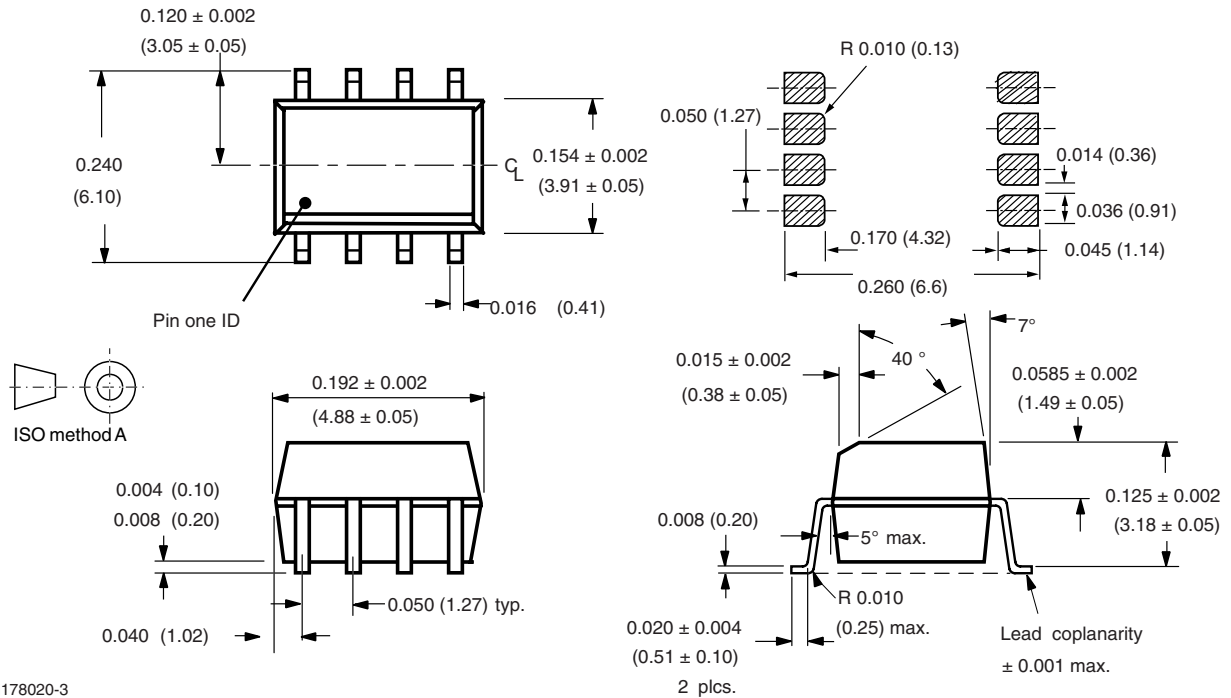

ESD CAUTION

This is an ESD (electro static discharge) sensitive device. Electrostatic charges accumulate on the human body and test equipment and can discharge without detection. Therefore, proper ESD precautions are recommended to avoid performance degradation or loss of functionality. ESD withstand voltage of this device is up to 1500 V acc. to JESD22-A114-B.

**OZONE DEPLETING SUBSTANCES POLICY STATEMENT**

It is the policy of Vishay Semiconductor GmbH to

1. Meet all present and future national and international statutory requirements.
2. Regularly and continuously improve the performance of our products, processes, distribution and operating systems with respect to their impact on the health and safety of our employees and the public, as well as their impact on the environment.

It is particular concern to control or eliminate releases of those substances into the atmosphere which are known as ozone depleting substances (ODSs).

The Montreal Protocol (1987) and its London Amendments (1990) intend to severely restrict the use of ODSs and forbid their use within the next ten years. Various national and international initiatives are pressing for an earlier ban on these substances.

Vishay Semiconductor GmbH has been able to use its policy of continuous improvements to eliminate the use of ODSs listed in the following documents.

1. Annex A, B and list of transitional substances of the Montreal Protocol and the London Amendments respectively.
2. Class I and II ozone depleting substances in the Clean Air Act Amendments of 1990 by the Environmental Protection Agency (EPA) in the USA
3. Council Decision 88/540/EEC and 91/690/EEC Annex A, B and C (transitional substances) respectively.

Vishay Semiconductor GmbH can certify that our semiconductors are not manufactured with ozone depleting substances and do not contain such substances.

We reserve the right to make changes to improve technical design
and may do so without further notice.

Parameters can vary in different applications. All operating parameters must be validated for each customer application by the customer. Should the buyer use Vishay Semiconductors products for any unintended or unauthorized application, the buyer shall indemnify Vishay Semiconductors against all claims, costs, damages, and expenses, arising out of, directly or indirectly, any claim of personal damage, injury or death associated with such unintended or unauthorized use.

Vishay Semiconductor GmbH, P.O.B. 3535, D-74025 Heilbronn, Germany



Notice

Specifications of the products displayed herein are subject to change without notice. Vishay Intertechnology, Inc., or anyone on its behalf, assumes no responsibility or liability for any errors or inaccuracies.

Information contained herein is intended to provide a product description only. No license, express or implied, by estoppel or otherwise, to any intellectual property rights is granted by this document. Except as provided in Vishay's terms and conditions of sale for such products, Vishay assumes no liability whatsoever, and disclaims any express or implied warranty, relating to sale and/or use of Vishay products including liability or warranties relating to fitness for a particular purpose, merchantability, or infringement of any patent, copyright, or other intellectual property right.

The products shown herein are not designed for use in medical, life-saving, or life-sustaining applications. Customers using or selling these products for use in such applications do so at their own risk and agree to fully indemnify Vishay for any damages resulting from such improper use or sale.