

High Efficiency LED Driver

Thank you very much for purchasing high efficiency LED drivers!
Please read this manual carefully and thoroughly before using the products.

Features

- Wide input voltage range: DC 8V ~ 32V, compatible with 12V/24V full voltage range
- High-precision constant current control ,control precision less than $\pm 2\%$
- Advanced high frequency pre-switching off current control for realization of high conversion efficiency, reliability and stability
- Efficiency is not less than 93% in 12V system, and not less than 95% in 24V system. The peak efficiency is as high as 96%.
- High-power density design, small volume and easy installation
- Power driven-filter using long-life metalized thin-film capacitor to assure life span of LED driver
- Output current can be adjusted accordingly within ranges of rated power and current
- High stability liner PWM duty cycle dimmer control
- Extensive electronic protection: input polarity reverse protection, output short circuit protection and output open circuit protection
- Industrial grade working temperature : - 40°C ~ + 65 °C
- PCB resin treatment for high moisture proof and antifogging
- Natural cooling
- Optional LED driver controller which can realize max. 4 -timer working. For each timer, 0~9 working hours and 0~100% output power is adjustable. The output power can also be adjusted automatically with changes of battery voltage and temperature (Please refer to controller's user's manual)

Wiring

Typical application wiring diagram shows as below: If no dimmer function need, please refer to Diagram1. If dimmer function needed, please refer to Diagram 2. **Pay more attention to '+' and '-'.**

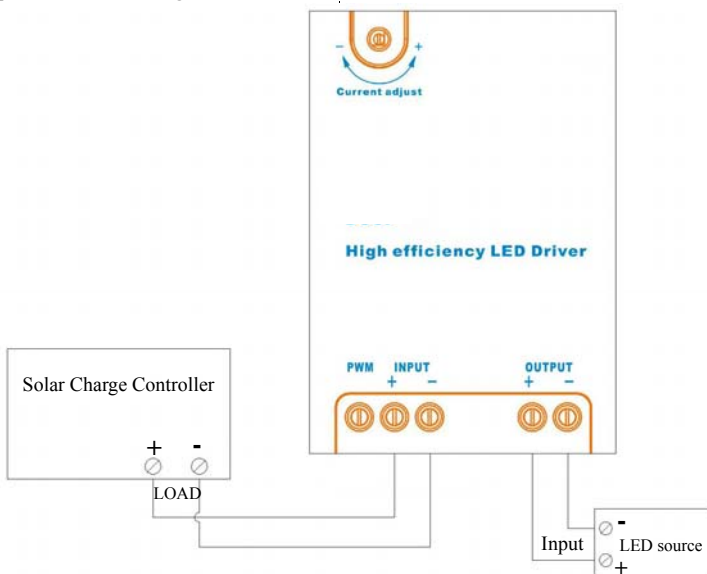

Diagram 1

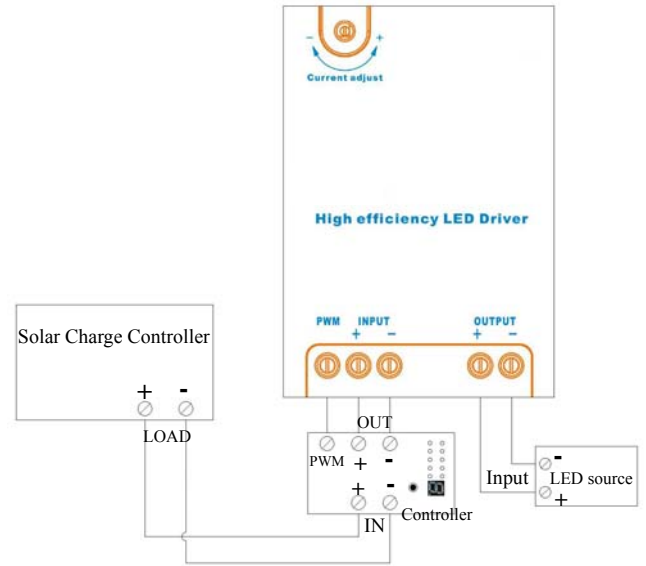

Diagram 2

Power adjustment

When adjust the output current via potentiometer, the output power will vary accordingly. Please use a small '-' screwdriver to rotate the knob 'Current adjustment' as below pictures. Users can adjust the output power as per actual demands. Please monitor the current with high-precision instruments to guarantee the reliability of power adjustment.

Clockwise for reducing power: Anticlockwise for increasing power:



Notes: For testing purpose, user can adjust the input voltage by power supply instead of battery. However, please confirm that both input voltage and input current cannot exceed the specified values (refer to Parameters), otherwise LED driver may be damaged. For example, when adjust 60W 60V driver from 24V,60W to 12V,30W,please adjust the output power to 30W first. Then adjust the input voltage to 12V.Because when battery changes, the current will vary inversely so as to keep the constant output power.

Notes: The default setting for the driver shows as below:

40W: 12V,20W; 60W: 12,30W; 100W: 12,50W.

Parameters

LED Driver Series

Nominal voltage	12V/24VDC compatible
Input voltage range	8 ~ 32VDC
Output current precision	< 2%
Typical efficiency	12V input: 93%; 24V input: 95%
PWM dimmer control	PWM: 0% ~ 100%; Output Power: 0W ~ Nominal

40W

Output voltage range: Decided by LED	Max. input ~ 60V
Max. output power	12V: 20W 24V: 40W
Max. input current	2A
Output current range	0.3 ~ 2A (Limited by Max. input power)

60W

Output voltage range: Decided by LED	Max. input ~ 60V
Max. output power	12V: 30W 24V: 60W
Max. input current	3A
Output current range	0.3 ~ 3A (Limited by Max. input power)

100W

Output voltage range: Decided by LED	Max. input ~ 60V
Max. output power	12V: 50W 24V: 100W
Max. input current	5A
Output current range	0.3 ~ 5A (Limited by Max. input power)

Others

Type	DCCP40	DCCP60	DCCP100
Ambient Temp.	-40°C ~ +65°C		
Storage Temp.	-40°C ~ +85°C		
Humidity	0 ~ 95% N.C.		
Enclosure	IP30		
Altitude	≤5000m		
Overall (mm)	101 x 66 x 27	108 x 69 x 27	116x74.5x32.5
Mounting (mm)	93 (vertical)	100 (vertical)	105.8(vertical)
Mounting hole	Φ5 (R2.46)		
Terminal	2.5mm ²		
Net Weight	80g	95g	162g

Dimensions (mm)

40W:

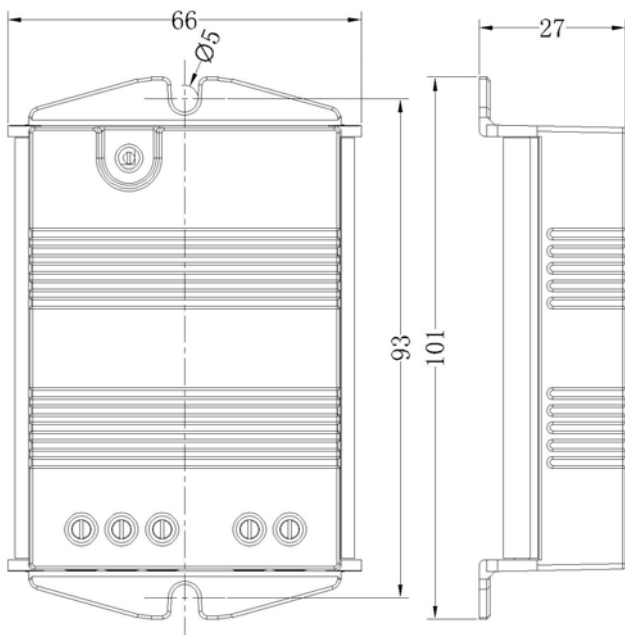

60W:

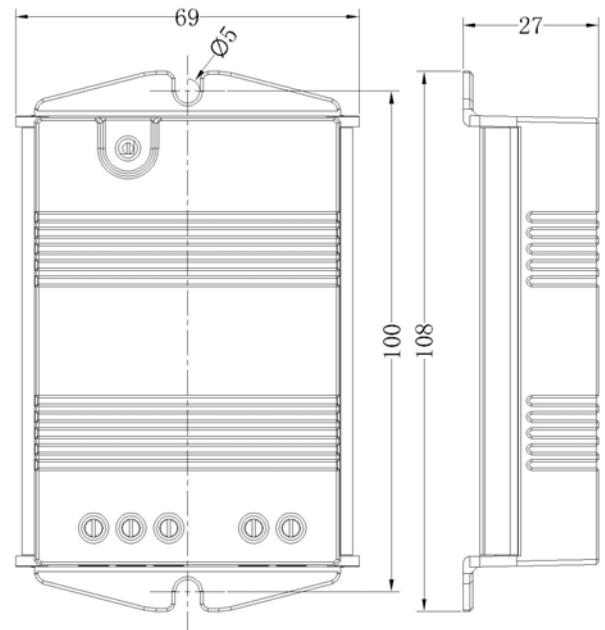

100W:

