

GPS Engine Board

SR-87

SiRF Star III

V 1.2

User Manual



IWASHI 

Contents

1. Introduction	2
1.1 Overview	2
2. Technical Specifications	3
2.1. Electrical Characteristics.....	3
2.2. Environmental Characteristics.....	4
2.3. Physical Characteristics.....	5
3. Applications	7
4. Operation and Test (optional).....	7
Appendix: Antenna Status sentence	8
Appendix: Software Specifications	9



1. Introduction

1.1. Overview

Product Introduction

The ProGin SR-87 series GPS modules incorporate high sensitivity, high performance SiRF StarIII chipset solution in a compact design. The module tracks up to 20 satellites at a time while offering fast time-to-first-fix and 1Hz navigation update. The unit is very suitable for broad applications such as Handheld, PDA, PPC or other battery operated navigation system.

Main Features

- High sensitivity SiRF StarIII chipsets.
- High performance receiver tracks up to 20 satellites.
- TTL output for GPS command interface.
- Low power consumption.
- Average Cold Start time under 42 seconds.
- On-chip 1Mb SRAM.
- Reacquisition time 0.1 second.
- Support accurate 1PPS output signal aligned with GPS timing.
- Support Standard NMEA-0183 and SiRF Binary protocol.
- Multi-path mitigation hardware.
- Built-in a lithium battery enables fast positioning.
- Compact size (25.4×25.4×7 mm³) for easy integration into hand-held devices.

The SR-87 design utilizes the latest surface mount technology and high level circuit integration to achieve superior performance while minimizing dimension and power consumption. This hardware capability combined with software intelligence makes the board easy to be integrated and used in all kinds of navigation applications or products. The module communicates with application system via RS232 (TTL level) with NMEA-0183 protocol.

Ordering information:

SR-87V-P, Vertical MMCX input with 1PPS Time mark output

SR-87V-S, Vertical MMCX input with GPS status indication

SR-87H-P, Horizontal MMCX input with 1PPS Time mark output

SR-87H-S, Horizontal MMCX input with GPS status indication



2. Technical Specifications

2.1. Electrical Characteristics

2.1.1 General

Frequency	L1, 1575.42 MHz
C/A code	1.023 MHz chip rate
Channels	20 channels all in view tracking

2.1.2 Sensitivity

Tracking	-159 dBm typical
----------	------------------

2.1.3 Accuracy (Open Sky)

Position	< 10 meters, 2D RMS < 7 meters 2D RMS, WAAS corrected 1-5 meters, DGPS corrected
Time	1 microsecond synchronized to GPS time

2.1.4 Datum

Default	WGS-84
---------	--------

2.1.5 Acquisition Rate

Hot start	1 sec, average
Warm start	38 sec, average
Cold start	42 sec, average
Reacquisition	0.1 sec, average

2.1.6 Dynamic Conditions

Altitude	< 18,000 meters (60,000 feet)
Velocity	< 515 meters/sec (1000 knots)
Acceleration	< 4 G
Jerk	20 meters/sec max

2.1.7 Power

Main power input	3.0 ~ 5.5 VDC input.
Supply Current	< 40 mA
Backup Power	3V rechargeable Lithium battery, up to 500 hours discharge



2.1.8 RF Interface

Antenna connector type MMCX

2.1.9 Serial Port

Electrical interface Two full duplex serial communication, via RS232, TTL interface.

Protocol message NMEA-0183.

Default NMEA GGA, GSA, GSV, RMC, (GLL, VTG, and ZDA optional).

4800 baud rate (other rate optional).

8 bits data, 1 stop bit, no parity.

Antenna Status sentence ZANTAX /ZANTA(Optional)

2.1.10 Time

1PPS Pulse, Pulse duration 1 μ s.

Time reference at the pulse positive edge.

Synchronized to GPS time, \pm 1 μ s.

2.1.11 Weight

< 8g

2.1.12 Recommended External Antenna Specification

Gain 20 dB min (cable loss included)

Noise figure 1.5 dB typical

Current 10 mA typical

Operating Voltage Confirmed to spec 3.3 ~ 5.5 V

Survival 3.0 ~ 3.3 V

2.2. Environmental Characteristics

Operating temperature range -40 °C to +85 °C

Storage temperature range -45 °C to +100 °C

2.3. Physical Characteristics

Mechanical Outline

SR-87V outline

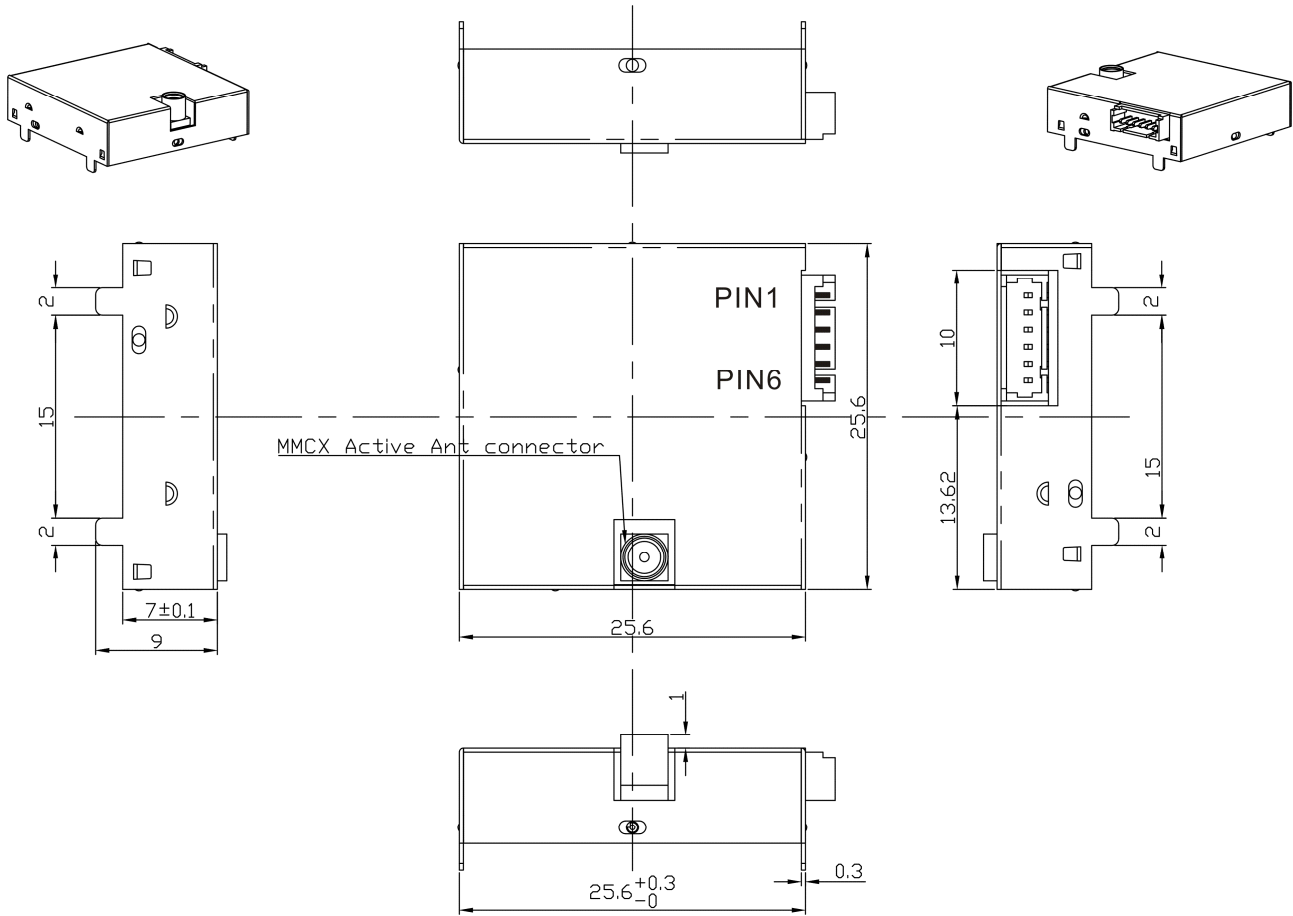

SR-87H outline

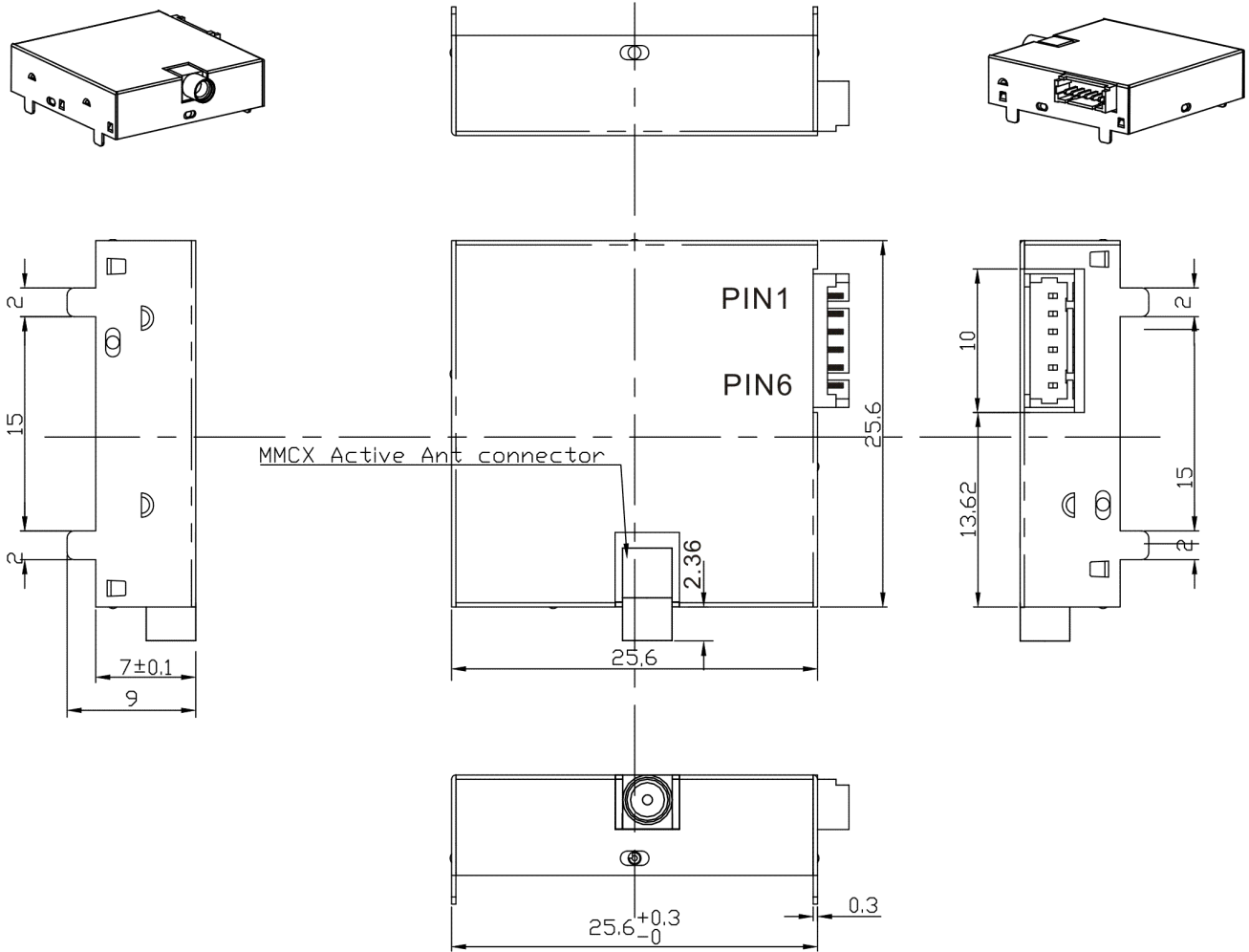

Unit : mm

Pin assignment

Pin1	VDD	3.0 ~ 5.5 VDC input
Pin2	UART Tx	NMEA serial data output
Pin3	UART Rx	Serial data input
Pin4	NC	Not connect, must be floating for normal operation
Pin5	GND	Ground
Pin6	TIMEMARK/ RESET/ GPS STATUS	TIMEMARK: 1PPS Time mark output (Pulse duration 1μs)/ RESET: Reset Input (Active Low)/ For GPS status (LED) indication



3. Applications

The SR-87 series engine module is a high performance, ultra low power consumption, GPS receiver. Applications are as follows:

- Car Navigation
- Wrist Watch
- Solar Operated Device
- Marine Navigation
- Fleet Management
- AVL and Location-Based Services
- Radar detector with GPS function
- Hand-Held Device for Personal Positioning and Navigation
- Ideal for PDA, Pocket PC and Other Computing Devices at GPS Application

4. Operation and Test (optional)

The customers can change the data protocol and communication data baud rate for their applications using a GPS Viewer software. Installing appropriate viewer program to host device, you may check the status of the GPS receiver whenever you like to. Following are standard buttons and operation steps.

- (a) Execute the Viewer program. Press the “COM” button to set “Com Port” for this data link and “Baud Rate” to 4800.
- (b) Click “OPEN” to download the received data. Usually one window shows the NMEA format data stream and another window shows tracked satellite constellation and signal quality status.
- (c) Once the link is successful, click “CLOSE” button to exit the program. However, you may click the “Cold” button to perform “cold start” testing.



Appendix: Antenna Status sentence (Optional)

For SR-87 (ZANTAX)

\$ZANTAX,0,0,0,0*xx							
Field	Message ID	Antenna Port	Reserved	Reserved	Reserved	Checksum	Message terminator
Format	\$ZANTAX	int	int	int	int	*xx	<CR><LF>
Note	Message for specified user	External antenna status: 0: external antenna normal 1: external antenna open/short	Reserved	Reserved	Reserved		ASCII 13, ASCII 10
Example	\$ZANTAX	0	0	0	0	*xx	

For SR-87-S (ZANTA)

\$ZANTA,0,0,0,0*xx							
Field	Message ID	Antenna Port	Reserved	Reserved	Reserved	Checksum	Message terminator
Format	\$ZANTA	int	int	int	int	*xx	<CR><LF>
Note	Message for specified user	External antenna status: 0: external antenna normal 1: external antenna open/short	Reserved	Reserved	Reserved		ASCII 13, ASCII 10
Example	\$ZANTA	0	0	0	0	*xx	



Appendix: Software Specifications

NMEA Protocol

The SR-87 software is capable of supporting the following NMEA message formats specifically developed and defined by SiRF.

NMEA Message Prefix	Format	Direction
\$GPGGA	Time, position and fix type data.	Out
\$GPGLL	Latitude, longitude, time of position fix and status.	Out
\$GPGSA	GNSS DOP and active satellites	Out
\$GPGSV	Satellites in view.	Out
\$GPMSS	Radio beacon signal-to-noise ratio, signal strength, frequency, etc.	Out
\$GPRMC	Recommended minimum specific GNSS data.	Out
\$GPVTG	Speed and course over ground.	Out
\$GPZDA	Date and time.	Out

General NMEA Format

The general NMEA format consists of an ASCII string commencing with a '\$' character and terminating with a <CR><LF> sequence. NMEA standard messages commence with 'GP' then a 3-letter message identifier. The message header is followed by a comma delimited list of fields optionally terminated with a checksum consisting of an asterisk '*' and a 2 digit hex value representing the checksum. There is no comma preceding the checksum field. When present, the checksum is calculated as a bitwise exclusive of the characters between the '\$' and '*'. As an ASCII representation, the number of digits in each number will vary depending on the number and precision, hence the record length will vary. Certain fields may be omitted if they are not used, in which case the field position is reserved using commas to ensure correct interpretation of subsequent fields.



\$GPGGA

This message transfers global positioning system fix data. Following is an example.

\$GPGGA,161229.487,3723.2475,N,12158.3416,W,1,07,1.0,9.0,M,, ,0000*18

The \$GPGGA message structure is shown below:

Field	Example	Unit	Notes
Message ID	\$GPGGA		GGA protocol header.
UTC Time	161229.487		hhmmss.sss
Latitude	3723.2475		ddmm.mmmm
N/S Indicator	N		N=north or S=south.
Longitude	12158.3416		dddmm.mmmm
E/W indicator	W		E=east or W=west.
Position Fix Indicator	1		0: Fix not available or invalid. 1: GPS SPS mode, fix valid. 2: Differ. GPS, SPS mode, fix valid 3-5: Not supported. 6: <i>Dead Reckoning Mode, fix valid.</i> ⁽¹⁾
Satellites Used	07		Number of satellites used to calculate fix. Range 0 to 12.
HDOP	1.0		Horizontal Dilution of Precision.
MSL Altitude ⁽²⁾	9.0	Meter	Altitude above mean seal level.
Units	M	Meter	M stands for “meters”.
Geoid Separation ⁽²⁾		Meter	Separation from Geoids can be blank.
Units		Meter	M stands for “meters”.
Age of Diff. Corr.		Second	Age in seconds. Blank (Null) fields when DGPS is not used.
Diff Ref. Station ID	0000		
Checksum	*18		
<CR> <LF>			Message terminator.

(1) Only apply to NMEA version 2.3 (and later) in this NMEA message description.

(2) **SiRF does not support geoid corrections. Values are WGS84 ellipsoid heights.**



\$GPGLL

This message transfers geographic position, latitude, longitude, and time. Following is an example.

\$GPGLL,3723.2475,N,12158.3416,W,161229.487,A,A*41

The \$GPGLL message structure is shown below:

Field	Example	Unit	Notes
Message ID	\$GPGLL		GLL protocol header.
Latitude	3723.2475		ddmm.mmmm
N/S Indicator	N		N=north or S=south.
Longitude	12158.3416		dddmm.mmmm
E/W indicator	W		E=east or W=west.
UTC Time	161229.487		hhmmss.sss
Status	A		A: Data valid or V: Data invalid.
Mode	A		<i>A=Autonomous, D=DGPS, E=DR (Only present in NMEA version 3.00).</i>
Checksum	*41		
<CR><LF>			Message terminator.



\$GPGSA

This message transfers DOP and active satellites information. Following is an example.

\$GPGSA,A,3,07,02,26,27,09,04,15,,,,,1.8,1.0,1.5*33

The \$GPGSA message structure is shown below:

Field	Example	Unit	Notes
Message ID	\$GPGSA		GSA protocol header.
Mode	A		M: Manual, forced to operate in selected 2D or 3D mode. A: Automatic switching between modes.
Mode	3		1 Fix not available. 2 2D position fix. 3 3D position fix.
Satellites Used ⁽¹⁾	07		SV on channel 1.
Satellites Used ⁽¹⁾	02		SV on channel 2.
...			..
Satellites Used ⁽¹⁾			SV on channel 12.
PDOP	1.8		
HDOP	1.0		
VDOP	1.5		
Checksum	*33		
<CR> <LF>			Message terminator.

(1) Satellites used in solution.



\$GPGSV

This message transfers information about satellites in view. The \$GPGSV message structure is shown below. Each record contains the information for up to 4 channels, allowing up to 12 satellites in view. In the final record of the sequence the unused channel fields are left blank with commas to indicate that a field has been omitted. Following is an example.

\$GPGSV,2,1,07,07,79,048,42,02,51,062,43,26,36,256,42,27,27,138,42*71

\$GPGSV,2,2,07,09,23,313,42,04,19,159,41,15,12,041,42*41

The \$GPGSV message structure is shown below:

Field	Example	Unit	Notes
Message ID	\$GPGSV		GSA protocol header.
Number of messages ⁽¹⁾	2		Number of messages, maximum 3.
Message number	1		Sequence number, range 1 to 3.
Satellites in view	07		Number of satellites currently in view.
Satellite ID	07		Channel 1, ID range 1 to 32.
Elevation	79	degree	Elevation of satellite, maximum 90.
Azimuth	048	degree	Azimuth of satellite, range 0 to 359.
SNR (C/N ₀)	42	dBHz	Range 0 to 99, null when not tracking.
Satellite ID	02		Channel 2, ID range 1 to 32.
Elevation	51	degree	Elevation of satellite, maximum 90.
Azimuth	062	degree	Azimuth of satellite, range 0 to 359.
SNR (C/N ₀)	43	dBHz	Range 0 to 99, null when not tracking.
Satellite ID	26		Channel 3, ID range 1 to 32.
Elevation	36	degree	Elevation of satellite, maximum 90.
Azimuth	256	degree	Azimuth of satellite, range 0 to 359.
SNR (C/N ₀)	42	dBHz	Range 0 to 99, null when not tracking.
Satellite ID	27		Channel 4, ID range 1 to 32.
Elevation	27	degree	Elevation of satellite, maximum 90.
Azimuth	138	degree	Azimuth of satellite, range 0 to 359.
SNR (C/N ₀)	42	dBHz	Range 0 to 99, null when not tracking.
Checksum	*71		
<CR> <LF>			Message terminator.

(1) Depending on the number of satellites tracked multiple messages of GSV data may be required.



\$GPMSS

This message transfers information about radio beacon signal-to-noise ratio, signal strength, frequency, etc. Following is an example.

\$GPMSS,55,27,318.0,100,1,*57

The \$GPMSS message format is shown below.

Field	Example	Unit	Notes
Message ID	\$GPMSS		MSS protocol header.
Signal Strength	55	dB	SS of tracked frequency.
Signal-to-Noise Ratio	27	dB	SNR of tracked frequency.
Beacon Frequency	318.0	kHz	Currently tracked frequency.
Beacon Bit Rate	100		Bits per second.
<i>Channel Number ⁽¹⁾</i>	<i>1</i>		<i>The channel of the beacon being used if a multi-channel beacon receiver is used.</i>
Checksum	*57		
<CR> <LF>			Message terminator.

(1) Fields marked in italic red apply only to NMEA version 2.3 (and later) in this NMEA message description.



\$GPRMC

This message transfers recommended minimum specific GNSS data. Following is an example.

\$GPRMC,161229.487,A,3723.2475,N,12158.3416,W,0.13,309.62,120598, ,*10

The \$GPRMC message format is shown below.

Field	Example	Unit	Notes
Message ID	\$GPRMC		RMC protocol header.
UTC Time	161229.487		hhmmss.sss
Status	A		A: Data valid or V: Data invalid.
Latitude	3723.2475		ddmm.mmmm
N/S Indicator	N		N=north or S=south.
Longitude	12158.3416		ddmm.mmmm
E/W indicator	W		E=east or W=west.
Speed over ground	0.13	knot	Speed over ground
Course over ground	309.62	degree	Course over ground
Date	120598		ddmmyy, current date.
Magnetic variation ⁽¹⁾		degree	Not used.
<i>Mode</i> ⁽²⁾	A		A=Autonomous, D=DGPS, E=DR.
Checksum	*10		
<CR> <LF>			Message terminator.

(1) SiRF does not support magnetic declination. All “course over ground” data are geodetic WGS84 directions.

(2) Fields marked in italic red apply only to NMEA version 2.3 (and later) in this NMEA message description.



\$GPVTG

This message transfers velocity, course over ground, and ground speed. Following is an example.

\$GPVTG,309.62,T, ,M,0.13,N,0.2,K,A*23

The \$GPVTG message format is shown below.

Field	Example	Unit	Notes
Message ID	\$GPVTG		VTG protocol header.
Course (true)	309.62	degree	Measured heading
Reference	T		T = true heading
Course (magnetic)		degree	Measured heading
Reference ⁽¹⁾	M		M = magnetic heading ⁽¹⁾
Speed	0.13	knot	Speed in knots
Units	N		N = knots
Speed	0.2	km/hr	Speed
Units	K		K = km/hour.
<i>Mode</i> ⁽²⁾	A		<i>A=Autonomous, D=DGPS, E=DR.</i>
Checksum	*23		
<CR> <LF>			Message terminator.

(1) SiRF does not support magnetic declination. All “course over ground” data are geodetic WGS84 directions.

(2) Fields marked in italic red apply only to NMEA version 2.3 (and later) in this NMEA message description.



\$GPZDA

This message transfers UTC Time and Date. Following is an example.

\$GPZDA,181813,14,10,2003,00,00*4F

The \$GPZDA message format is shown below.

Field	Example	Unit	Notes
Message ID	\$GPZDA		ZDA protocol header.
UTC Time	181813		Either using valid IONO/UTC or estimated from default leap seconds.
UTC Day	14		01 to 31, day of month.
UTC Month	10		01 to 12.
UTC Year	2003		1980 to 2079.
Local zone hours	00		Offset from UTC (set to 00).
Local zone minutes	00		Offset from UTC (set to 00).
Checksum	*4F		
<CR> <LF>			Message terminator.