

## **A TWO-STAGE 1 kW SOLID-STATE LINEAR AMPLIFIER**

Prepared by: **Helge O. Granberg**  
RF Circuits Engineering

### **INTRODUCTION**

This application note discusses the design of 50 W and 300 W linear amplifiers for the 1.6 to 30 MHz frequency band. Both amplifiers employ push-pull design for low, even harmonic distortion. This harmonic distortion and the 50 Vdc supply voltage make the output impedance matching easier for 50-Ohm interface, and permits the use of efficient 1:1 and 4:1 broadband transformers.

Modern design includes integrated circuit bias regulators and the use of ceramic chip capacitors throughout the RF section, making the units easily mass producible.

Also, four 300 W modules are combined to provide a 1 to 1.2 kW PEP or CW output capability. The driver amplifier increases the total power gain of the system to approximately 34 dB.

Although the transistors employed (MRF427 and MRF428) are 100% tested against 30:1 load mismatches, in case of a slight unbalance, the total dissipation ratings may be well exceeded in a multi-device design. With high drive power available, and the power supply current limit set at much higher levels, it is always possible to have a failure in one of the push-pull modules under certain load mismatch conditions. It is recommended that some type of VSWR based protective circuitry be adapted in the equipment design, and separate dc regulators with appropriate current limits provided for each module.

The MRF428 is a single chip transistor with the die size of 0.140 x 0.248", and rated for a power output of 150 W PEP or CW. The single chip design eliminates the problem of selecting two matched die for balanced power distribution and dissipation. The high total power dissipation rating (320 W) has been achieved by decreasing the thermal resistance between the die and the mount by reducing the thickness of the BeO insulator to 0.04" from the standard 0.062", resulting in  $R_{\theta JC}$  as low as 0.5°C/W.

The MRF427 is also a single chip device. Its die size is 0.118 x 0.066", and is rated at 25 W PEP or CW. This being a high voltage unit, the package is larger than normally seen with a transistor of this power level to prevent arcing between the package terminals.

The MRF427 and MRF428 are both emitter-ballasted, which insures an even current sharing between each cell, and thus improving the device ruggedness against load mismatches.

The recommended collector idling currents are 40 mA and 150 mA respectively. Both devices can be operated in Class A, although not specified in the data sheet, providing the power dissipation ratings are not exceeded.

### **GENERAL DESIGN CONSIDERATIONS**

Similar circuit board layouts are employed for the four 300 W building block modules and the preamplifier. A compact design is achieved by using ceramic chip capacitors, of which most can be located on the lower side of the board. The lead lengths are also minimized resulting in smaller parasitic inductances and smaller variations from unit-to-unit.

Loops are provided in the collector current paths to allow monitoring of the individual collector currents with a clip-on current meter, such as the HP-428B. This is the easiest way to check the device balance in a push-pull circuit, and the balance between each module in a system such as this.

The power gain of each module should be within not more than 0.25 dB from each other, with a provision made for an input Pi attenuator to accommodate device pairs with larger gain spreads. The attenuators are not used in this device however, due to selection of eight closely matched devices.

In regards to the performance specifications, the following design goals were set:

**Devices:** 8 x MRF428 + 2 x MRF427A

**Supply Voltage:** 40 – 50 V

$\eta$ , **Worst Case:** 45% on CW and 35% under two-tone conditions

**IMD,  $d_3$ :** – 30 dB Maximum (1 kW PEP, 50 V and 800 W PEP, 40 V)

**Power Gain, Total:** 30 dB Minimum

**Gain Variation:** 2.0 – 30 MHz:  $\pm 1.5$  dB Maximum

**Input VSWR:** 2.0:1 Maximum

**Continuous CW Operation, 1 kW:** 50% Duty Cycle, 30-minute periods, with heatsink temperature < 75°C .

**Load Mismatch Susceptibility:** 10:1, any phase angle

Determining the figures above is based on previous performance data obtained in test circuits and broadband amplifiers. Some margin was left for losses and phase errors occurring in the power splitter and combiner.

### **THE BIAS VOLTAGE SOURCE**

Figure 1 shows the bias voltage source employed with each of the 300 W modules and the preamplifier. Its basic components are the integrated circuit voltage regulator MC1723C, the current boost transistor Q3 and the temperature sensing diode D1.



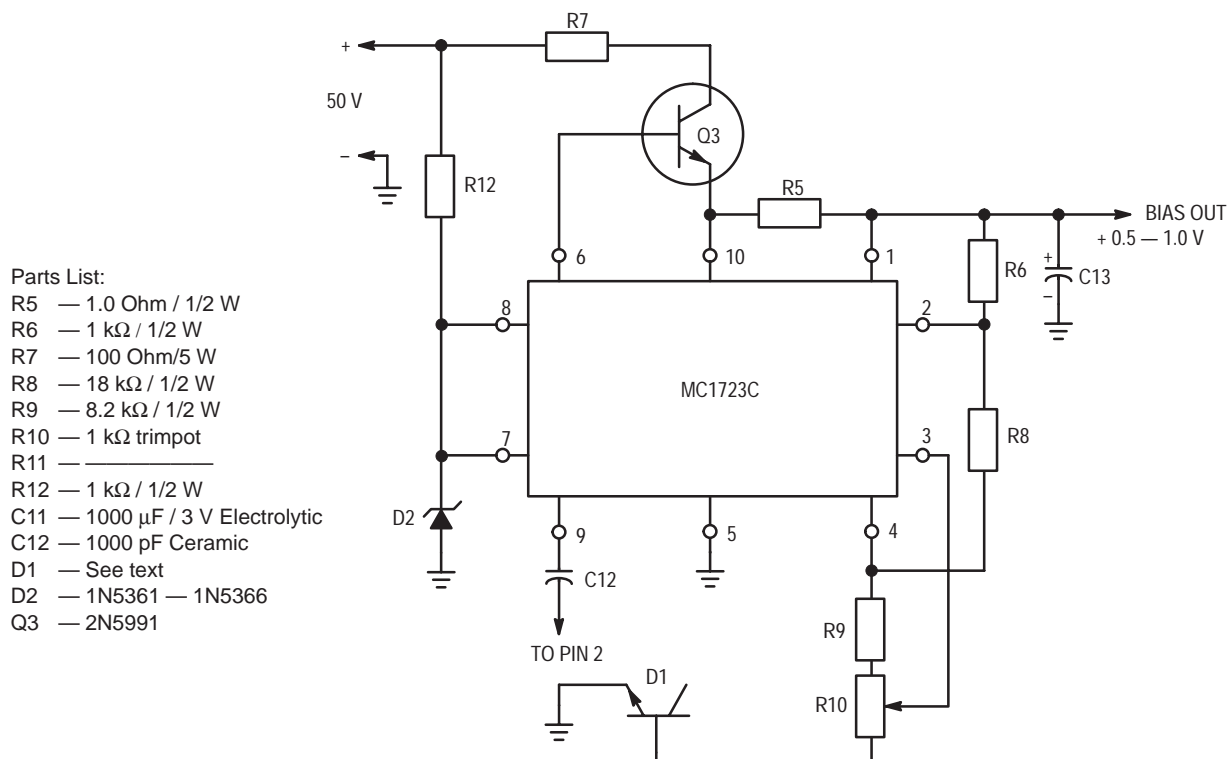

Figure 1. Bias Voltage Source

Although the MC1723C is specified for a minimum  $V_O$  of 2 Volts, it can be used at lower levels with relaxed specifications, which are sufficient for this application. Advantages of this type bias source are:

1. Line voltage regulation, which is important if the amplifier is to be operated from various supply voltages.
2. Adjustable current limit.
3. Very low stand-by current drain.

Figure 1 is modified from the circuit shown on the MC1723 data sheet by adding the temperature sensing diode D1 and the voltage adjust element R10. D2 and R12 reduce the supply voltage to a level below 40 V, which is the maximum input voltage of the regulator.

D1 is the base-emitter junction of a 2N5190, in a Case 77 plastic package. The outline dimensions allow its use for one of the circuit board stand-offs, attaching it automatically to the heatsink for temperature tracking.

The temperature compensation has a slight negative coefficient. When the collector idling current is adjusted to 300 mA at 25°C, it will be reduced to 240 – 260 mA at a 60°C heatsink temperature. (– 1.15 to – 1.7 mA/°C.)

The current limiting resistor R5 sets the limiting to approximately 0.65 A, which is sufficient for devices with a minimum  $h_{FE}$  of 17,

$$I_B = \frac{I_C}{h_{FE}}$$

when the maximum average  $I_C$  is 10.9 A. (2 MHz, 50 V, 250 CW.) Typically, the MRF428  $h_{FE}$ 's are in the 30's.

The measured output voltage variations of the bias source (0 – 600 mA) are  $\pm 5$  to 7 mV, which amounts to a source impedance of approximately 20 milliohms.

## THE 300 W AMPLIFIER MODULE

### Input Matching

Due to the large emitter periphery of the MRF428, the series base impedance is as low as 0.88, – J.80 Ohm at 30 MHz. In a push-pull circuit a 16:1 input transformer would provide the best impedance match from a 50-Ohm source. This would however, result in a high VSWR at 2 MHz, and would make it difficult to implement the gain correction network design. For this reason a 9:1 transformer, which is more ideal at the lower frequencies, was chosen. This represents a 5.55 Ohm base-to-base source impedance.

In a Class C push-pull circuit, where the conduction angle is less than 180°, the base-to-base impedance would be about four times the base-to-emitter impedance of one device. In Class A where the collector idling current is approximately half the peak collector current, the conduction angle is 360°, and the base-to-base impedance is twice the input impedance of one transistor. When the forward base bias is applied, the conduction angle increases and the base-to-base impedance decreases rapidly, approaching that of Class A in Class AB.

A center tap, common in push-pull circuits, is not necessary in the input transformer secondary, if the transistors are balanced. ( $C_{iB}$ ,  $h_{FE}$ ,  $V_{BEf}$ ) The base current return path is through the forward biased base-emitter junction of the off transistor. This junction acts as a clamping diode, and the power gain is somewhat dependent upon the amount of the bias current. The equivalent input circuit (Figure 2) represents one half of the push-pull circuit, and for calculations  $R_S$  equals the total source impedance ( $R_{S'}$ ) divided by two.

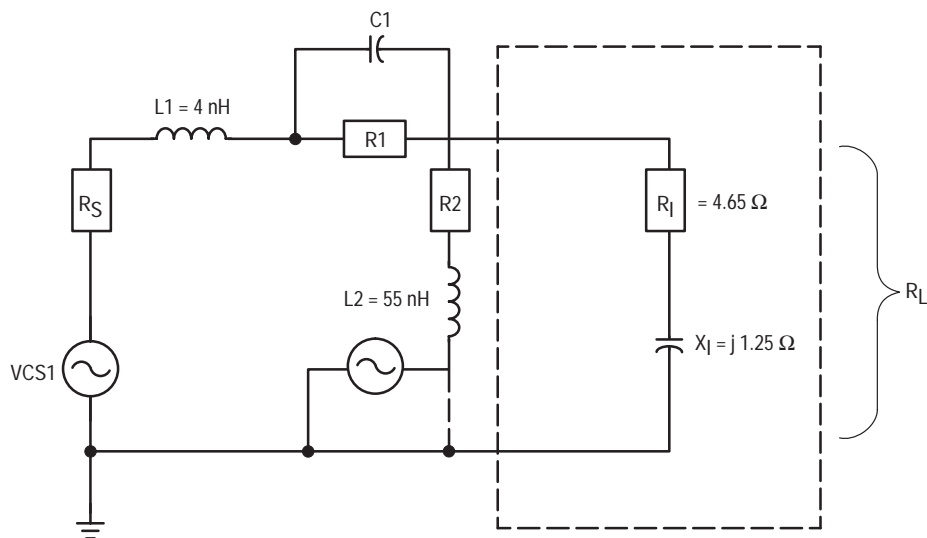

Figure 2. Equivalent Base Input Circuit

Since a junction transistor is a current amplifier, it should ideally be driven from a current source. In RF applications this would result in excessive loss of power gain. However, input networks can be designed with frequency slopes having some of the current source characteristics at low frequencies, where excess gain is available.

The complex base input characteristics of a transistor would place requirements for a very sophisticated input compensation network for optimum overall performance. The design goal here was to maintain an input VSWR of 2:1 or less and a maximum gain variation of + 1.5 dB from 2 to 30 MHz. Initial calculations indicated that these requirements can be met with a simple RC network in conjunction with negative collector-to-base feedback. Figure 2 shows this network for one device. L1 and L2 represent lead lengths, and their values are fixed. The feedback is provided through R2 and L2. Because the calculations were done without the feedback, this branch is grounded to simulate the operating conditions.

The average power gain variation of the MRF428 from 2 to 30 MHz is 13 dB. Due to phase errors, a large amount of negative feedback in an RF amplifier decreases the linearity, or may result in instabilities. Experience has shown that approximately 5 – 6 dB of feedback can be tolerated without noticeable effects in linearity or stability, depending upon circuit layout. If the amount of feedback is 5 dB, 8 dB will have to be absorbed by the input network at 2 MHz.

Omitting the reactive components, L1, L2, C1, and the phase angle of X1 which have a negligible effect at 2 MHz, a simple L-pad was calculated with  $R_S = 2.77 \Omega$ , and

$$R_L = \sqrt{4.65^2 + 1.25^2} = 4.81 \Omega$$

From the device data sheet we find  $G_{PE}$  at 2 MHz is about 28 dB, indicating 0.24 W at  $R_L$  will produce an output power of 150 W, and the required power at  $R_S = 0.24 \text{ W} + 8 \text{ dB} = 1.51 \text{ W}$ .

Figuring out currents and voltages in various branches results in:  $R1 = 1.67 \Omega$  and  $R2 = 1.44 \Omega$ .

The calculated values of R1 and R2 along with other known values and the device input data at four frequencies

were used to simulate the network in a computer program. An estimated arbitrary value of 4000 pF for C1 was chosen, and VCS2 represents the negative feedback voltage (Figure 2.) The optimization was done in two separate programs for R1, R2, C1 and VCS2 and in several steps. The goals were: a) VCS and R2 for a transducer loss of 13 dB at 2 MHz and minimum loss at 30 MHz. b) R1 and C1 for input VSWR of < 1.1:1 and < 2:1 respectively. The optimized values were obtained as:

$$\begin{aligned} C1 &= 5850 \text{ pF} & R2 &= 1.3 \Omega \\ R1 &= 2.1 \Omega & VCS2 &= 1.5 \text{ V} \end{aligned}$$

The minimum obtainable transducer loss at 30 MHz was 2.3 dB, which is partly caused by the highest reflected power at this frequency, and can be reduced by "overcompensation" of the input transformer. This indicates that at the higher frequencies, the source impedance ( $R_S$ ) is effectively decreased, which leaves the input VSWR highest at 15 MHz.

In the practical circuit the value of C1 (and C2) was rounded to the nearest standard, or 5600 pF. For each half cycle of operation R2 and R4 are in series and the value of each should be

$$\frac{1.3 \Omega}{2}$$

for  $VCS2 = 1.5 \text{ V}$ . Since the voltage across ac and bd =  $V_{CE}$ , a turns ratio of 32:1 would be required. It appears that if the feedback voltage on the bases remains unchanged, the ratio of the voltage across L5 (VCS2) and R2R4 can be varied with only a small effect to the overall input VSWR. To minimize the resistive losses in the bifilar winding of T2 (Figure 3), the highest practical turns ratio should not be much higher than required for the minimum inductance, which is

$$\frac{4R}{2\pi f} = \frac{50}{12.5} = 4.0 \mu\text{H}$$

$R = \text{Collector-to-Collector Impedance} = 12.5 \Omega$

$f = 2 \text{ MHz}$

ac or bd will then be 1.0  $\mu\text{H}$ , which amounts to 5 turns. (See details on T2.) 25% over this represents a 7:1 ratio setting VCS2 to 6.9 V.

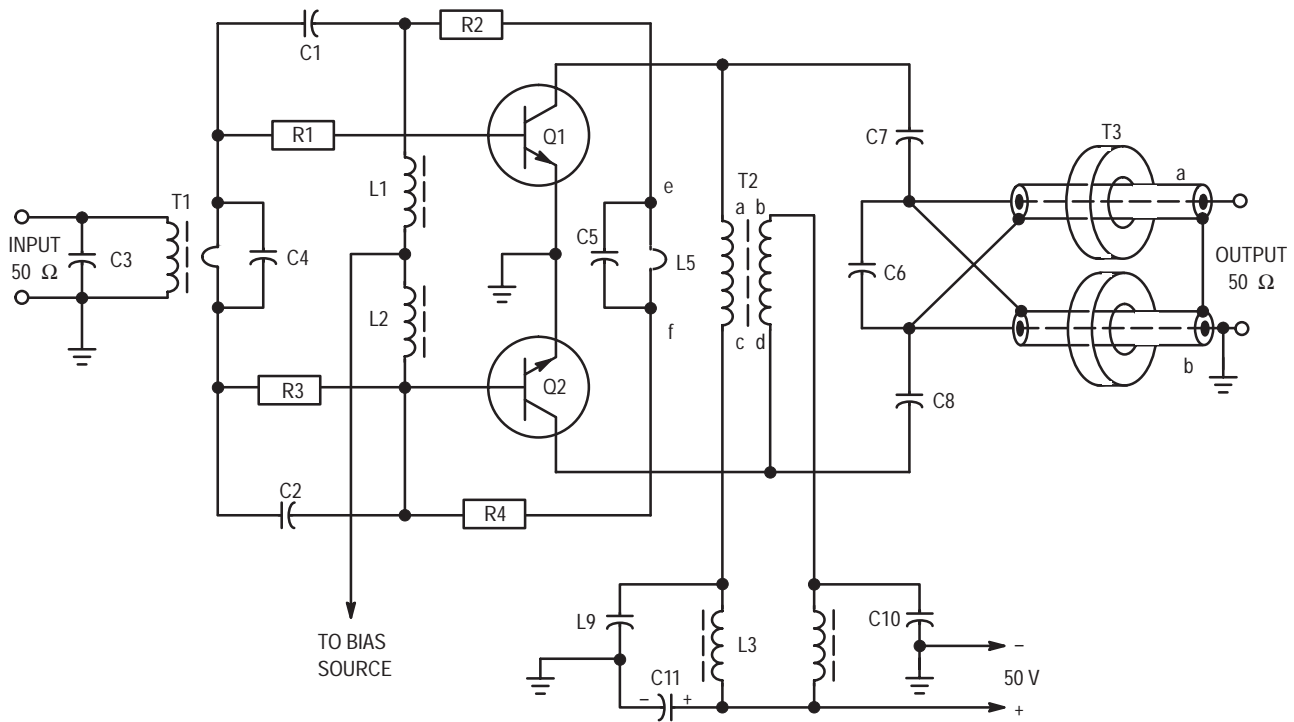

Figure 3.

In addition to providing a source for the negative feedback, T2 supplies the dc voltage to the collectors as well as functions as a center tap for the output transformer T3.

The currents for each half cycle are in opposite phase in ac and bd, and depending on the coupling factor between the windings, the even harmonic components will see a much lower impedance than the fundamental. The optimum line impedance for ac, bd would equal one half the collector-to-collector impedance, but experiments have shown that increasing this number by a factor of 2–3 affects the 2nd and 4th harmonic amplitudes by only 1 to 2 dB.

Since the minimum gain loss obtainable at 30 MHz with network as in Figure 2, and the modified VCS2 source was about 3.8 dB at 30 MHz, C5 was added with the following in mind: C5 and L5 form a parallel resonant circuit with a Q of approximately 1.5. Its purpose is to increase the shunting impedance across the bases, and to disturb the 180° phase difference between the input signal and the feedback voltage at the higher frequencies. This reduces the gain loss of 3.8 dB, of which 1.4 dB is caused by the feedback at 30 MHz. The amount depends upon the resonant frequency of C5 L5, which should be above the highest operating frequency, to avoid possible instabilities.

When L5 is 45 nH, and the resonance is calculated for

35 MHz, the value of C5 becomes 460 pF, which can be rounded to the closest standard, or 470 pF. The phase shift at 30 MHz is:

$$\begin{aligned} \tan^{-1} \left[ \frac{2\pi fL}{R \left( 1 - \frac{f^2}{f_0^2} \right)} \right] &= \tan^{-1} \left[ \frac{6.28 \times 30 \times 0.045}{6.8 \left( 1 - \frac{900}{1225} \right)} \right] \\ &= \tan^{-1} \left( \frac{8.48}{1.80} \right) = 78.0^\circ \end{aligned}$$

The impedance is:

$$\frac{R}{\cos \theta} = \frac{6.8}{\cos 78^\circ} = 32.7 \Omega$$

At 2 MHz the numbers are respectively 4.76° and 6.83 Ω.

The 1.4 dB feedback means that the feedback voltage is 16% of the input voltage at the bases. By the aid of vectors, we can calculate that the 78° phase shift and the increased impedance reduces this to 4%, which amounts to 0.35 dB. These numbers were verified in another computer program with VCS2 = 6.9 V, and including C5. New values for R1 and R2 were obtained as 1.95 Ω and 6.8 Ω respectively, and other data as shown in Table 1.

Table 1.

Frequency MHz	Input VSWR	Input Impedance Real	Input Impedance Reactive	Attenuation dB
2.0	1.07	2.79	-0.201	13.00
4.0	1.16	2.66	-0.393	12.07
7.5	1.33	2.35	-0.615	10.42
15	1.68	1.77	-0.611	7.40
20	1.82	1.57	-0.431	5.90
30	1.74	1.62	-0.21	2.70

Although omitted from the preliminary calculations, the  $2 \times 5$  nH inductances, comprising of lead length, were included in this program.

The input transformer is a 9:1 type, and uses a television antenna balun type ferrite core, made of high permeability material. The low impedance winding consists of one turn of 1/8" copper braid. The sections going through the openings in the ferrite core are rounded to resemble two pieces of tubing electrically. The primary consists of AWG #22 TFE insulated wire, threaded through the rounded sections of braid, placing the primary and secondary leads in opposite ends of the core.<sup>(4)</sup> <sup>(5)</sup> The saturation flux density is about 60 gauss which is well below the limits for this core. For calculation procedures, see discussion about the output transformer.

This type physical arrangement provides a tight coupling, reducing the amount of leakage flux at high frequencies. The wire gauge, insulation thickness, and number of strands have a minimal effect in the performance except at very high impedance ratios, such as 25:1 and up. The transformer configuration is shown in Figure 4. By using a vector impedance meter, the values for C3 and C4 were measured to give a reasonable input match at 30 MHz, ( $Z_{in} = 1.62 - j 0.21 \times 2 = 3.24 - j 0.42$ ) with the smallest possible phase angle.

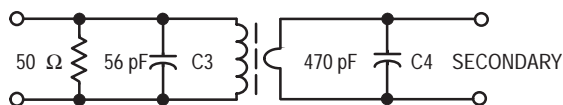

Figure 4. Transformer Configuration

When the high impedance side was terminated into 50  $\Omega$ , the following readings were obtained at the secondary: The VSWR was calculated as

$$\frac{Z1 - Z2}{Z1 + Z2}$$

where:

Z1 = Impedance at transformer secondary.

Z2 = Input impedance of compensation network  $\times 2$  ( $R_S$  in Figures 2 and 3) as in computer data presented ahead.

The effect of the lower VSWR to the power loss in the input network can be calculated as follows:

$$10 \text{ Log } \left\{ \frac{\left[ 1 - \left( \frac{S1 - 1}{S1 + 1} \right)^2 \right]}{\left[ 1 - \left( \frac{S2 - 1}{S2 + 1} \right)^2 \right]} \right\}$$

where:

S1 = VSWR 1 (Lower)

S2 = VSWR 2 (Higher)

$$\text{which at 30 MHz} = 10 \text{ Log } \left\{ \frac{\left[ 1 - \left( \frac{1.11 - 1}{1.11 + 1} \right)^2 \right]}{\left[ 1 - \left( \frac{1.74 - 1}{1.74 + 1} \right)^2 \right]} \right\}$$

$$= 10 \text{ Log } \left( \frac{0.997}{0.927} \right) = 0.32 \text{ dB}, 2.7 - 0.32 = 2.38 \text{ dB}$$

These figures for other frequencies are presented with the data below. Later, some practical experiments were done with moving the resonance of C5 L5 lower, to find out if instabilities would occur in a practical circuit. When the resonance was equal to the test frequency, slight breakup was noticed in the peaks of a two-tone pattern. It was then decided to adjust the resonance to 31 MHz, where C5 = 560 pF, and the phase angle at 30 MHz increases to 87°. The transducer loss is further reduced by about 0.2 dB.

Table 2.

Frequency MHz	$R_S$ Ohms	$X_S$ Ohms	VSWR	Attenuation dB
2.0	5.59	+ 0.095	1.05	12.99
4.0	5.55	+ 0.057	1.15	12.06
7.5	5.50	+ 0.046	1.32	10.40
15	4.90	+ 0.25	1.48	7.28
20	4.32	+ 0.55	1.38	5.63
30	3.43	+ 0.73	1.11	2.38

\* Above readings with transformer and compensation network.

Several types of output transformer configurations were considered. The 12.5 Q collector-to-collector impedance estimated earlier, would require a 4:1 transformer for a 50  $\Omega$  output. The type used here as the input transformer exhibits good broad band characteristics with a convenient physical design. However, according to the low frequency minimum inductance formula presented earlier in connection with T2, the initial permeability required would be nearly 3000, with the largest standard core size available. High permeability ferrites are almost exclusively of Nickel-Manganese composition, and are lossy at radio frequencies. Although their Curie points are higher than those of lower permeability Nickel-Zinc ferrites, the core losses would degrade the amplifier performance. With the core losses being a function of the power level, these rules can sometimes be disregarded in low power applications.

A coaxial cable version was adapted for this design, since the transmission line type transformers are theoretically ideal for RF applications, especially in the 1:4 impedance ratio. A balanced to unbalanced function would normally require three separate transmission lines including a balun<sup>(5)</sup> <sup>(6)</sup>. It appears that the third line can be omitted, if lines a and b (Figure 3) are wound on separate magnetic cores, and the physical length of the lines is sufficient to provide the necessary isolation between the collectors and the load. In accordance to formulas in (7), the minimum line length required at 2 MHz, employing Stackpole 57-9074 or equivalent ferrite toroids is 4.2", and the maximum permissible line length at 30 MHz would be approximately 20". The 4.2" amounts to four turns on the toroid, and measures 1.0  $\mu$ H, which in series with the second line is sufficient for 2 MHz. Increasing the minimum required line length by a factor of 4 is still within the calculated limits, and in practical measurements the isolation has been found to be over 30 dB across the band. The main advantage with this arrangement is a simplified electrical and physical lay-out.

The maximum flux density of the toroids is approximately 200 gauss<sup>(3)</sup>, and the number of turns has been increased beyond the point where the flux density of the magnetic core is the power limiting factor.



The 1:4 output transformer is not the optimum in this case, but it is the closest practical at these power levels. The optimum power output at 50 V supply voltage and 50 Ω load is:

$$V_{RMS} = 4 \times (V_{CC} - V_{CE(sat)} \times 0.707) = 135.75 \text{ V,}$$

when  $V_{CE(sat)} = 2 \text{ V}$

$$I = \frac{135.75}{50} = 2.715 \text{ A, } P_{out} = 2.715 \times 135.75 = 368.5 \text{ W}$$

The optimum  $V_{CC}$  at  $P_{out} = 300 \text{ W}$  would be:

$$V_{CC} = V_{CE(sat)} + (\sqrt{R_{in} \times 2 P_{out}}) = 2 + (\sqrt{6.25 \times 300}) = 45.3 \text{ V}$$

The above indicates that the amplifier sees a lower load line, and the collector efficiency will be lowered by 1 – 2%. The linearity at high power levels is not affected, if the device  $h_{FE}$  is maintained at the increased collector currents. The linearity at low power levels may be slightly decreased due to the larger mismatch of the output circuit.

The required characteristic line impedance (a and b, Figure 3) for a 1:4 impedance transformer is:  $\sqrt{R_{in}R_L} = \sqrt{12.5 \times 50} = 25 \text{ } \Omega$ , enables the use of standard miniature 25 Ω coaxial cable (i.e., Microdot 260-4118-000) for the transmission lines. The losses in this particular cable at 30 MHz are 0.03 dB/ft. With a total line length of 2 x 16.8" (2 x 4 x 4.2"), the loss becomes 0.084 dB, or

$$300 - \left( \frac{300}{10^{\text{antilog } 0.084 \text{ dB}}} \right) = 5.74 \text{ W.}$$

For the ferrite material employed, Stackpole grade #11 (or equivalent Indiana General Q1) the manufacturers data is insufficient for accurate core loss calculations<sup>(6)</sup> The  $B_H$  curves indicate that 100 – 150 gauss is well in the linear region.

The toroids measure 0.87" x 0.54" x 0.25", and the 16.8" line length figured above, totals to 16 turns if tightly wound, or 12 – 14 turns if loosely wound. The flux density can then be calculated as:

$$B_{max} = \frac{V_{max} \times 102}{2\pi f n A}$$

- where: f = Frequency in MHz
- n = Total number of turns.
- A = Cross sectional area of the toroid in cm<sup>2</sup>.
- V = Peak voltage across the 50 Ω load,

$$\sqrt{\left( \frac{300}{50} \right) \left( \frac{50}{0.707} \right)} = 173 \text{ V}$$

$$B_{max} \text{ (for each toroid)} = \frac{86.5 \times 10^2}{6.28 \times 2 \times 28 \times .25} = 98.3 \text{ gauss}$$

Practical measurements showed the core losses to be negligible compared to the line losses at 2 MHz and 30 MHz. However, the losses increase as the square of  $B_{max}$  at low frequencies.

With the amount of HF compensation dependent upon circuit layout and the exact transformer construction, no calculations were made on this aspect for the input (or output) transformers. C3, C4, and C6 were selected by employing adjustable capacitors on a prototype whose values were then measured.

A photo of the circuit board is shown in Figure 5, A-bottom and B-top. The performance data of the 300 W module can be seen in Figure 6.

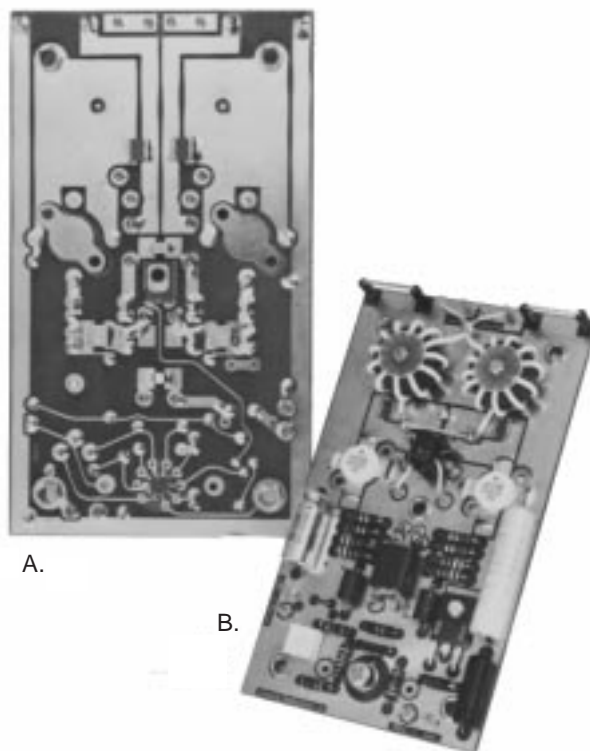

Figure 5. Bottom and Top of the 300 W Module Circuit Board

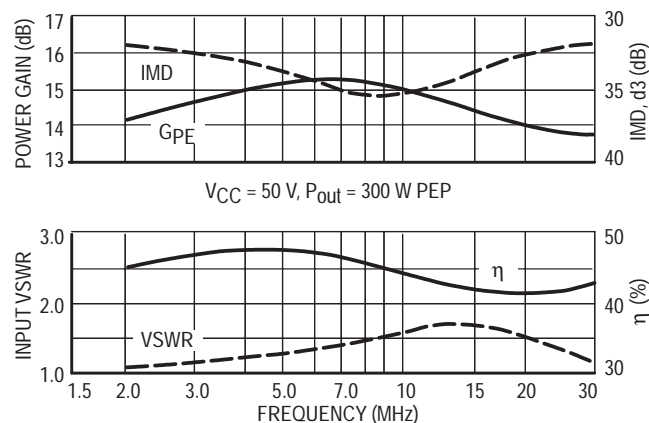

Figure 6. IMD, Power Gain, Input VSWR and Efficiency versus Frequency of a 300 W Module

### THE DRIVER AMPLIFIER

The driver uses a pair of MRF427 devices, and the same circuit board layout as the power amplifier, with the exception of the type of the output transformer.

The input transformer is equal to what is used with the power amplifier, but has a 4:1 impedance ratio. The required minimum inductance in the one turn secondary (Figures 3 and 4) being considerably higher in this case,

$$\frac{4R}{2\pi f} = \frac{4 \times 12.5}{12.5} = 4.0 \mu\text{H}$$

the  $A_L$  product of the core is barely sufficient. The measured inductances between a number of cores range 3.8 – 4.1  $\mu\text{H}$ .

This formula also applies to the output transformer, which is a 1:1 balun. The required minimum inductance at 2 MHz is 16  $\mu\text{H}$ , amounting to 11 turns on a Ferroxcube 2616P-A100-4C4 pot core, which was preferred over a toroid because of ease of mounting and other physical features. Although twisted wire line would be good at this power level, the transformer was wound with RG-196 coaxial cable, which is also used later for module-driver interconnections.

The required worst case driver output is  $s 4 \times 12 \text{ W} = 48 \text{ W}$ . The optimum  $P_{\text{Out}}$  with the 1:1 output transformer is:

$$\frac{V_{\text{RMS}}}{50} \times V_{\text{RMS}} = \frac{67.7}{50} \times 67.7 = 92 \text{ W.}$$

The MRF 427 is specified for a 25 W power output. Having a good  $h_{FE}$  versus  $I_C$  linearity, the 1 to 2 load mismatch has an effect of 2 – 3 dB in the IMD at the 10 power level, and the reduced efficiency in the driver is insignificant regarding the total supply current in the system.

The component values for the base input network and the feedback were established with the aid of a computer, and information on the device data sheet, as described earlier with the 300 W module. The HF compensation was done in a similar manner as well. Neither amplifier employs LF compensation. C7 and C8 are dc blocking capacitors, and their value is not critical.

In T2 (Figure 7), b and c represent the RF center tap, but are separated in both designs — partly because of circuit lay-out convenience and partly for stabilization purposes.

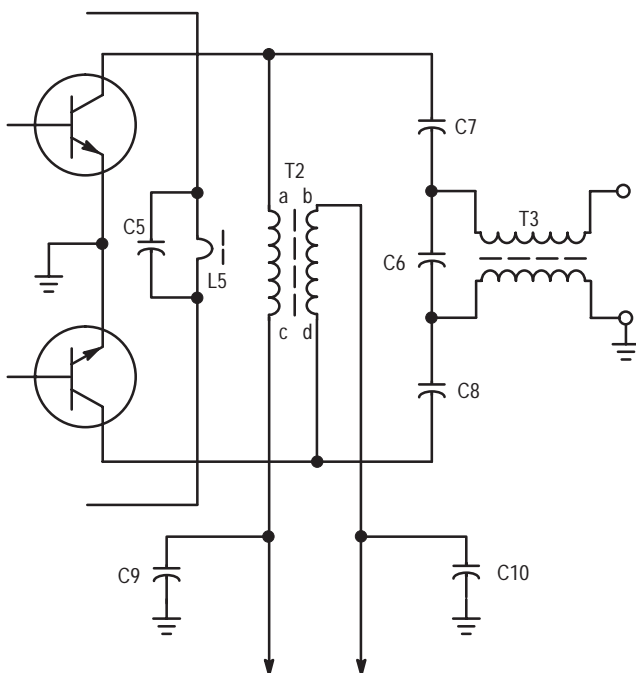

Figure 7.

The test data of the driver is presented later along with the final test results.

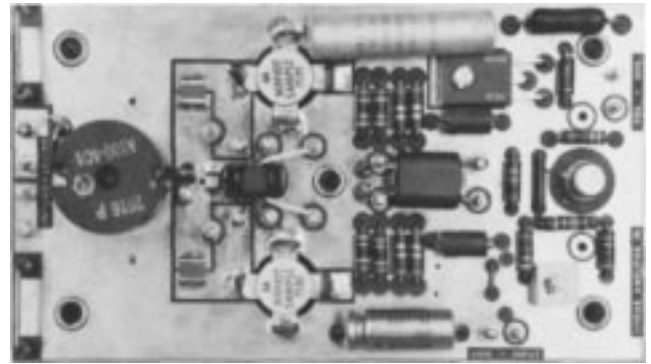

Figure 8. Driver Amplifier Board Layout

## COMBINING FOUR 300 W POWER MODULES

### The Input Power Divider

The purpose of the power divider is to divide the input power into four equal sources, providing an amount of isolation between each. The outputs are designed for 50  $\Omega$  impedance, which sets the common input at 12.5  $\Omega$ . This requires an additional 4:1 step down transformer to provide a 50  $\Omega$  load for the driver amplifier. Another requirement is a 0° phase shift between the input and the 50  $\Omega$  outputs, which can be accomplished with 1:1 balun transformers. (a, b, c and d in Figure 10.) For improved low frequency isolation characteristics the line impedance must be increased for the parallel currents. This can be done, without affecting the physical length of the line, by loading the line with magnetic material. In this type transformer, the currents cancel, making it possible to employ high permeability ferrite and a relatively short physical length for the transmission lines. In an absolutely balanced condition, no power will be dissipated in the magnetic cores, and the line losses are reduced. The minimum required inductance for each line can be calculated as shown for the driver amplifier output transformer, which gives a number of 16  $\mu\text{H}$  minimum at 2 MHz. A low inductance value degrades the isolation characteristics between the 50  $\Omega$  output ports, to maintain a low VSWR in case of a change in the input impedance of one or more of the power modules. However, because of the base compensation networks, the power splitter will never be subjected to a completely open or shorted load.

The purpose of the balancing resistors (R) is to dissipate any excess power, if the VSWR increases. Their optimum values, which are equal, are determined by the number of 50  $\Omega$  sources assumed unbalanced at one time, and the resistor values are calculated accordingly.

Examining the currents with one load open, it can be seen that the excess power is dissipated in one resistor in series with three parallel resistors. Their total value is  $50 - 12.5 = 37.5 \Omega$ . Similarly, if two loads are open, the current flows through one resistor in series with two parallel resistors, totaling 37.5  $\Omega$  again. This situation is illustrated in Figure 11.

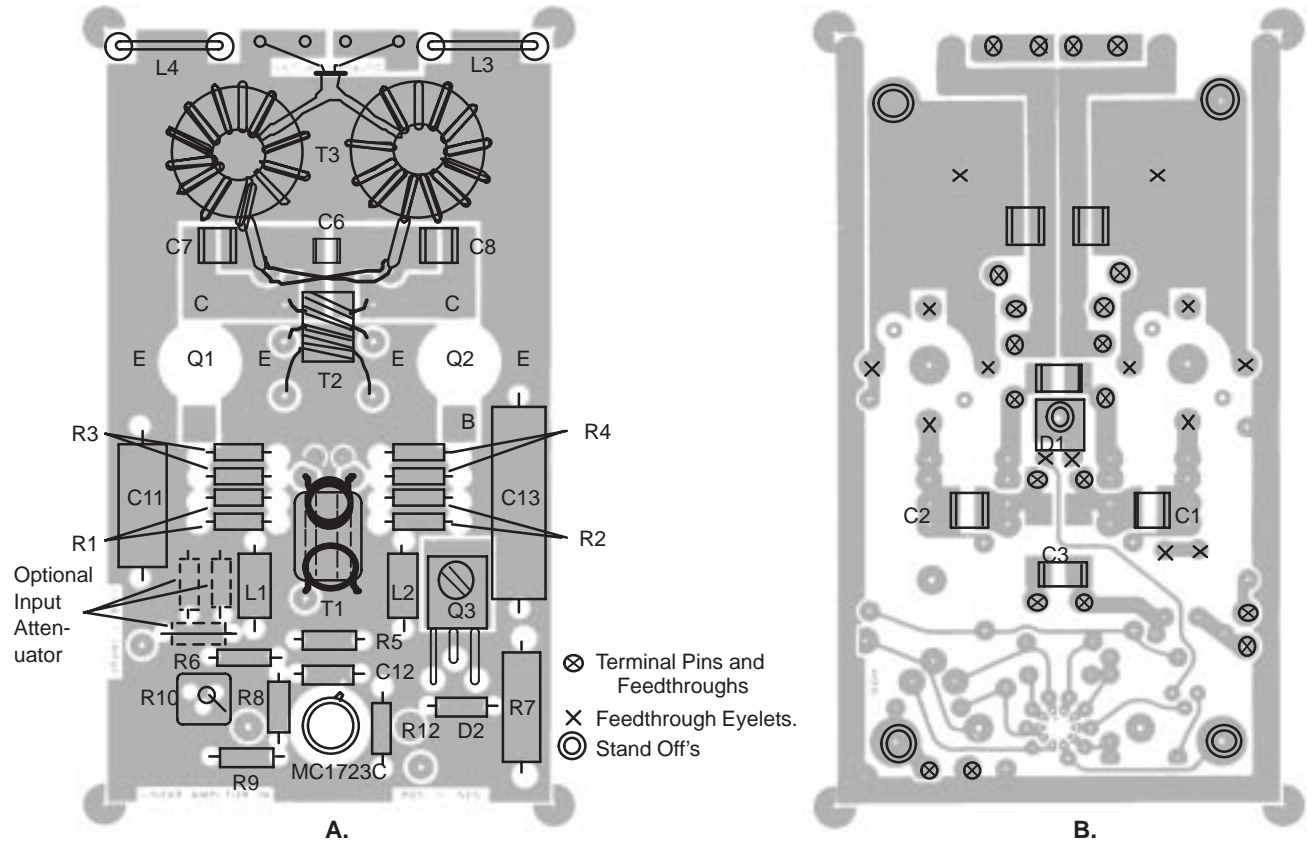

Figure 9. Component Layout of the 300 W Amplifier Module

**PARTS LIST\***  
(Power Module and Driver Amplifier)

	Power Module	Driver Amplifier
C1, C2	5600 pF	3300 pF
C3	56 pF	39 pF
C4	470 pF	Not Used
C5	560 pF	470 pF
C6	75 pF	51 pF
C7, C8	0.1 μF	0.1 μF
C9, C10	0.33 μF	0.33 μF
C11	10 μF/150 V	10 μF/150 V
R1, R2	2 x 3.9 Ω / 1/2 W in parallel	2 x 7.5 Ω / 1/2 W in parallel
R3, R4	2 x 6.8 Ω / 1/2 W in parallel	2 x 18 Ω / 1/2 W in parallel
L1, L2	Ferroxcube VK200 19/4B ferrite choke	Ferroxcube VK200 19/4B ferrite choke
L3, L4	6 ferrite beads each, Ferroxcube 56 590 65/3B	6 ferrite beads each, Ferroxcube 56 590 65/3B
	All capacitors, except C11, are ceramic chips. Values over 100 pF are Union Carbide type 1225 or 1813 or Varadyne size 18 or 14. Others ATC Type B.	
T1	9:1 type, see text. (Ferrite core for both: Stackpole 57-1845-24B or Fair-Rite Products 287300201 or equivalent.)	4:1 type, see text.
T2	7 turns of bifilar or loosely twisted wires. (AWG #20.) Ferrite cores for both: Stackpole 5-9322, Indiana General F627-8Q1 or equivalent.	
T3	14 turns of Microdot 260-4118-00 25 Ω miniature coaxial cable wound on each toroid. (Stackpole 57-9074, Indiana General F624-19Q1 or equivalent.)	11 turns of RG-196, 50 Ω miniature coaxial cable wound on a bobbin of a Ferroxcube 2616P-A100-4C4 pot core.

\* Parts and kits for this amplifier are available from Communication Concepts Inc., 508 Millstone Drive, Beavercreek, Ohio 45434-5840 (513) 426-8600.



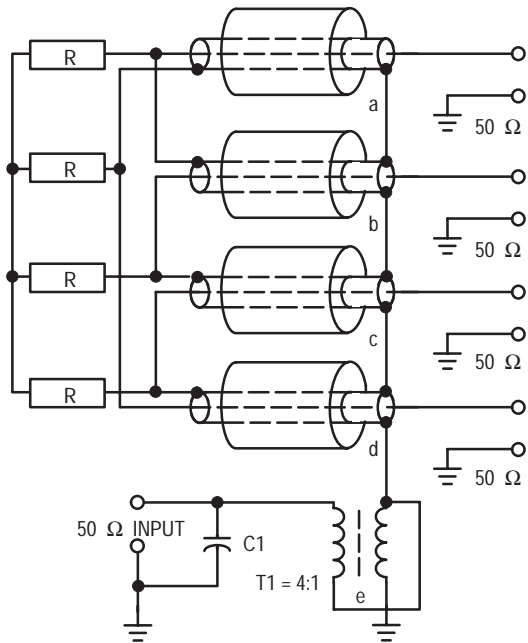

Figure 10. Four Port Power Divider

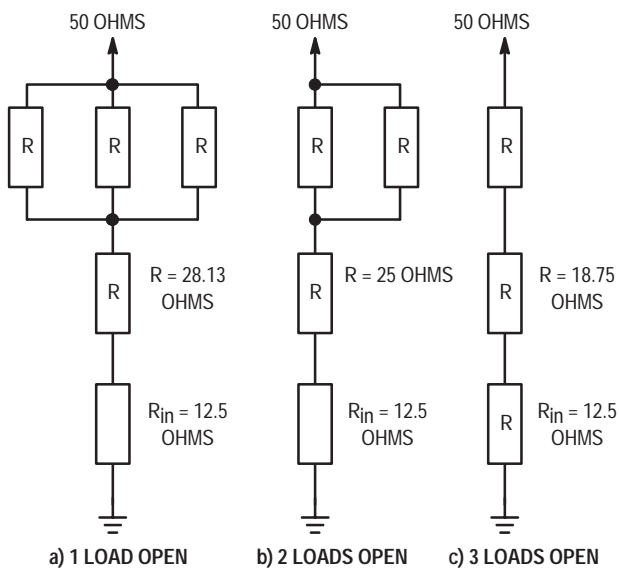

Figure 11.

Except for a two port power divider<sup>(5)</sup>, the resistor values can be calculated for odd or even number systems as:

$$R = \left( \frac{R_L - R_{in}}{n + 1} \right) n$$

where:  $R_L$  = Impedance of the output ports, 50 Ω.

$R_{in}$  = Impedance of the input port, 12.5 Ω.

$n$  = Number of output ports properly terminated.

Although these resistor values are not critical in the input divider, the formula also applies to the output power combiner, where mismatches have a larger effect in the total power output and linearity.

The practical power divider employs large ferrite beads (Fair-Rite Products 2673000801 or Stackpole 57-1511-24B

or equivalent) over a 1.2 inch piece of RG-196 coaxial cable. The arrangement is shown in Figure 10. Both above ferrite materials have a  $\mu_r$  of about 2500, and the inductance for one turn is in excess of 10  $\mu$ H.

The step-down transformer (T1, Figure 10) is wound on a Stackpole 57-9322-11 toroid with 25 Ω miniature coaxial cable. (Microdot 260-4118-000 or equivalent.) Seven turns will give a minimum inductance of 4/16  $\mu$ H, required at 2 MHz.

For the preamplifier interface, C1 could be omitted in order to achieve the lowest input VSWR.

The structure is mounted between two phenolic terminal strips as can be seen in the foreground of Figure 14, providing a sufficient number of tie points for the coaxial cable connections.

**THE OUTPUT COMBINER**

The operation of the output combiner is reversed from that of the input power divider. In this application we have four – 50 Ω inputs and one 12.5 Ω output, which is transformed to 50 Ω by a 1:4 impedance ratio transformer.

An arrangement similar to the input power divider is employed in the combiner. The baluns consist of straight pieces of coaxial cable loaded by a sleeve of magnetic material (ferrite). The line length is determined by the physical dimensions of the ferrite sleeves. The  $\mu_r$  versus cross sectional area should be calculated or measured to give sufficient loading inductance.

Straight line baluns as these have the advantage over multiturn toroidal types in introducing a smaller possibility for phase errors, due to the smaller length of the line. The largest possible phase errors occur in the input and output connecting cables, whose lengths are 18" and 10" respectively. All four input and output cables must be of equal length within approximately 1/4", and the excess in some, caused by the asymmetrical system layout, can be coiled or formed into loops.

The output connecting cables between the power amplifier outputs and the combiner are made of low loss RG-142B/U coaxial cable, that can adequately handle the 300 W power with the average current of 2.45 A.

The balun transmission lines are also made of RG-142B/U coaxial cable, with an outer diameter of 0.20". The line length is not critical as it is well below the maximum length permitted for 30 MHz<sup>(7)</sup>. The minimum inductance, as in the input divider, is 16  $\mu$ H per line. Measurements were made between two port combiners, one having the line inductance of 17  $\mu$ H (7 Ferroxcube 768 series 3E2A toroids) and the other 4.2  $\mu$ H (one Stackpole 57-0572-27A ferrite sleeve). The results are shown in Table 3.

Table 3.

f MHz	Isolation dB (Line Inductance 17 $\mu$ H)	Isolation dB (Line Inductance 4.2 $\mu$ H)
2.0	40.2	29.1
4.0	40.0	38.3
7.5	39.6	39.1
15	37.5	37.8
20	35.8	36.2
30	33.4	33.5

The main difference is at 2 MHz — and it was decided that the 29 dB of isolation is sufficient, as the high frequency isolation in either case is not much better. The 3E2A and other similar materials are rather lossy at RF, and with their low Curie points, would present a danger of overheating in case of a source unbalance.

Figure 12 shows the electrical design of the four-port power combiner.

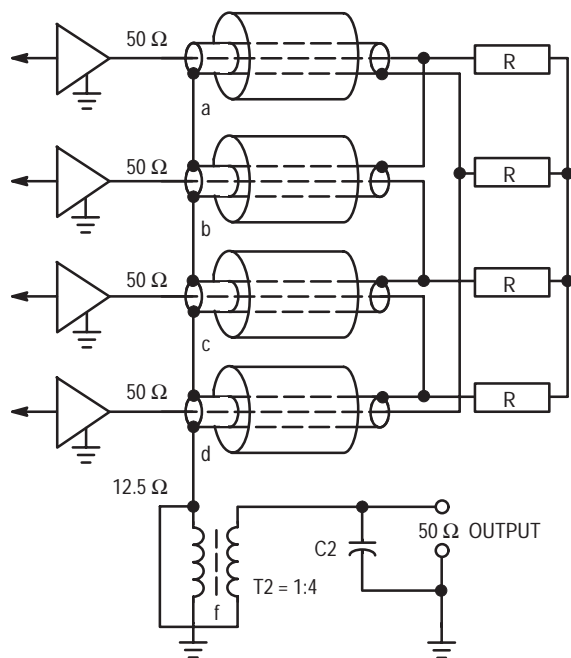

Figure 12. Four Port Output Combiner

The power output with various numbers of disabled sources, referring to Figures 11 and 12 can be calculated as:

$$P_n - P_R + \frac{P_R}{n}$$

where:  $n$  = Number of Operative Sources.  
 $P_n$  = Total Power of Operative Sources.  
 $P_R$  = Power Dissipated in Balancing Resistors.

For one disable source:

$$P_R = 250 \left( \frac{28.13}{50} \right) = 140.65 \text{ W}$$

$$P_{out} = (250 \times 3) - \left( 140.65 + \frac{140.65}{3} \right) = 750 - 187.5 = 562.5 \text{ W}$$

This is assuming that the phase errors between the active sources are negligible. Otherwise the formula in (7) can be adapted, but if the errors between the active sources are unequal, the situation will get rather complex.

From above we see that 140.65 W will be dissipated by one of the balancing resistors and only 15.6 W by the other three. For this high power dissipation the resistors must be the type which can be mounted to a heat sink, and noninductive. After experiments with the “noninductive” wirewound resistors which exhibited excess inductance at 30 MHz and were bulky with 50 and 100 W ratings, thin film terminations were specially fabricated in-house for this application.\* These terminations are deposited on a BeO wafer, which is attached to a copper flange. They are rated for 50 W continuous power, but can be operated at 100 or

even 150 W for nonextended periods if the flange temperature is kept moderately low. The balancing resistors can be seen on the upper side of the combiner, which is shown in the foreground of Figure 15.

The purpose of the step-up transformer T2, (Figure 12) is to transform the 12.5  $\Omega$  impedance from the combiner up to 50  $\Omega$ . It is a standard 1:4 unbalanced-to-unbalanced transmission line type transformer,<sup>(6, 7, 8)</sup> in which the line is made of two RG-188 coaxial cables connected in parallel in the manner as shown in Figure 13.

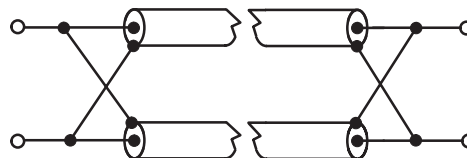

Figure 13.

Normally the loss in RG-188 at 30 MHz is 0.08 dB/foot. In this connection arrangement, the currents in both directions are carried by the braid in parallel with the inner conductor and the power loss is reduced to approximately 0.025 dB/foot. The impedance becomes 25  $\Omega$ , and depending on how close the cables are to each other physically, it can be as low as 22  $\Omega$ . The minimum line inductance can be calculated as shown before, and is 16  $\mu\text{H}$  for the 50  $\Omega$  side. This inductance is achieved by winding several turns of the dual cable line on a magnetic core. In contrast to the balun transformers in the combiner, the line currents do not cancel and the magnetic core must handle the full power, and must be made of lower loss material. The form of a toroid was figured to require the shortest line length for a specific inductance, and out of the standard sizes, two stacked units resulted in a shorter line length than a single larger one with similar cross sectional area.

Six turns on two Indiana General F626-12-Q1 toroids give 4.8 and 23  $\mu\text{H}$  for the secondary; the line length being 16 inches.

In continuous operation the core temperature was measured as 95 – 90°C. This resulted in a decision to change the core material to Q2, which exhibits about 70% lower losses at 30 MHz. The permeability is also lower (35), and with the same number of turns gives only 13  $\mu\text{H}$ .

The line length could not be increased according to (7), and the measurements indicated no difference in operation at 2 MHz, so the Q2 toroids with the low inductance were considered permanent.

The maximum flux density of the toroids is calculated as shown before:

$$B_{max} = \frac{V_{max} \times 10^2}{2\pi f \eta A} \text{ gauss}$$

where:  $V$  = Peak voltage across the secondary, (50 point) 316.2 V  
 $f$  = Frequency in MHz (2.0)  
 $\eta$  = Number of turns at the 50  $\Omega$  point. (12)  
 $A$  = Core cross sectional area (1.21  $\text{cm}^2$ )

$$B_{max} = \frac{316.2 \times 10^2}{6.28 \times 2 \times 12 \times 1.21} = 260 \text{ gauss}$$

\* Similar attenuators and terminations are available from Solitron, EMC Technology, Inc., and other manufacturers of microwave components.

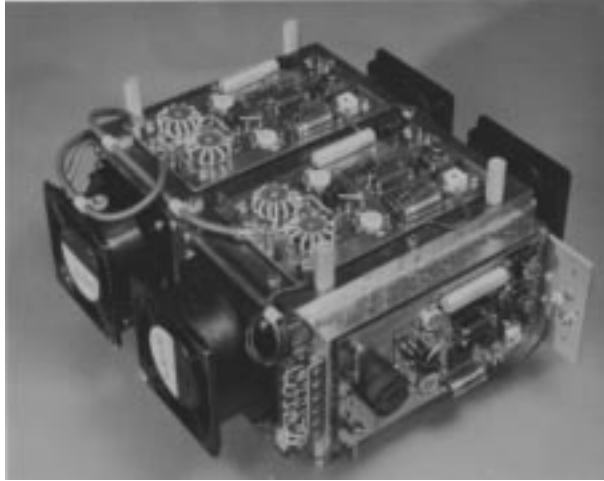

**Figure 14. 1 kW Linear Amplifier showing the input power divider in the foreground, to the right is the preamplifier. Two of the four 300 W modules can be seen on the upper side of the structure. The other two modules are shown in Figure 15.**

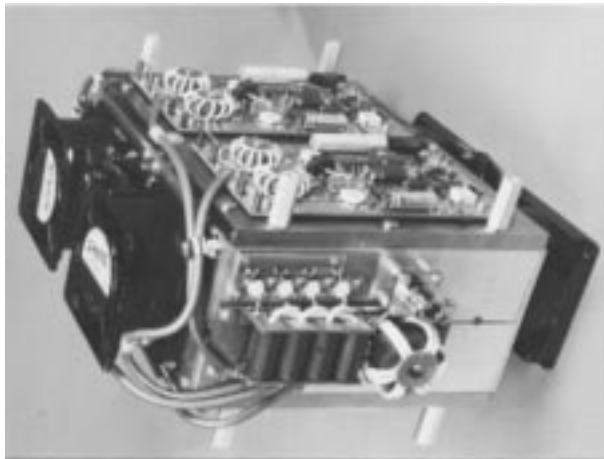

**Figure 15. 1 kW Linear Amplifier showing the output combiner in the foreground, to the right is the 1:4 stepup transformer. The four balancing resistors, mounted to the heat sink, can be seen directly above the combining network.**

From the BH curves we can see that the linear portion extends to 800 – 1000 gauss, and the saturation occurs at over 3000 gauss. Comparable materials are Stackpole grade 14 and Fair-rite products 63.

The core losses are minimal compared to the line losses, which for the 16" length amount to 0.035 dB or 0.81%.

As in the input transformer, the HF compensation (C2) was not required. The lay-out of the combiner and T2 is such that minimum lead lengths are obtained, and the structure is mounted on a PC board having feedthrough eyelets to a continuous ground plane on its lower side.

## MEASUREMENTS

Six 300 W modules were built using matched pair production MRF428's. The maximum gain distribution was 0.9 dB, and in the four units selected for the amplifier, the gain varied from 13.7 to 14.1 dB at 30 MHz, so it was not necessary to utilize the option of the input attenuators.

Figure 16 shows the test set-up arrangement employed for testing the modules and the combined amplifier.

The heatsink design was not optimized as it was felt to be outside the scope of this report; concentration was made in the electrical design. However, it was calculated to be sufficient for short period testing under two-tone or CW conditions at full power. The heatsink consists of four 9" lengths of Thermalloy 6151 extrusion, each having a free air thermal resistance of 0.7°C/W. They are bolted in pairs to two 9" x 8 1/2" x 3/8" copper plates, to which the four power modules are mounted. Assuming a coefficient of 0.85 between two parallel extrusions, a total thermal resistance of 0.4°C/W is realized. Two of these dual extrusions are mounted back-to-back to provide a channel for the air flow from four Rotron SP2A2 4" fans. Two are mounted in each end of the heatsink, and the four fans operating in the same direction provide an air flow of approximately 150 CFM.

The third order harmonic is 14 dB below the fundamental at certain frequencies, as can be seen in Figure 22. This number is typical in a four octave amplifier, and it is obvious that some type of output filter is required when it is used for communications purposes.

The 10:1 load mismatch was simulated with 34 feet of RG-58 coaxial cable, which has an attenuation of approximately 0.9 dB at 30 MHz, representing 1.8 dB return loss. The coaxial was terminated into an LC network consisting of a 2 x 15 — 125 pF variable capacitor and two inductors as shown in Figure 23.

The high current mode appears at a phase angle of  $-90^\circ$  and 20  $\Omega$ , where the monitored individual collector currents increased to 6.8 A. At 50 V this amounts to 340 W, which almost entirely represents device dissipation.

At 20:1 load mismatch an equal power dissipation is reached at a power output of approximately 650 W CW.

Since the collector voltages remain below the device breakdown at the high impedance mode ( $+90^\circ$ , 150  $\Omega$ ), it may be concluded, that the load mismatch susceptibility is limited by overdissipation of the transistors.

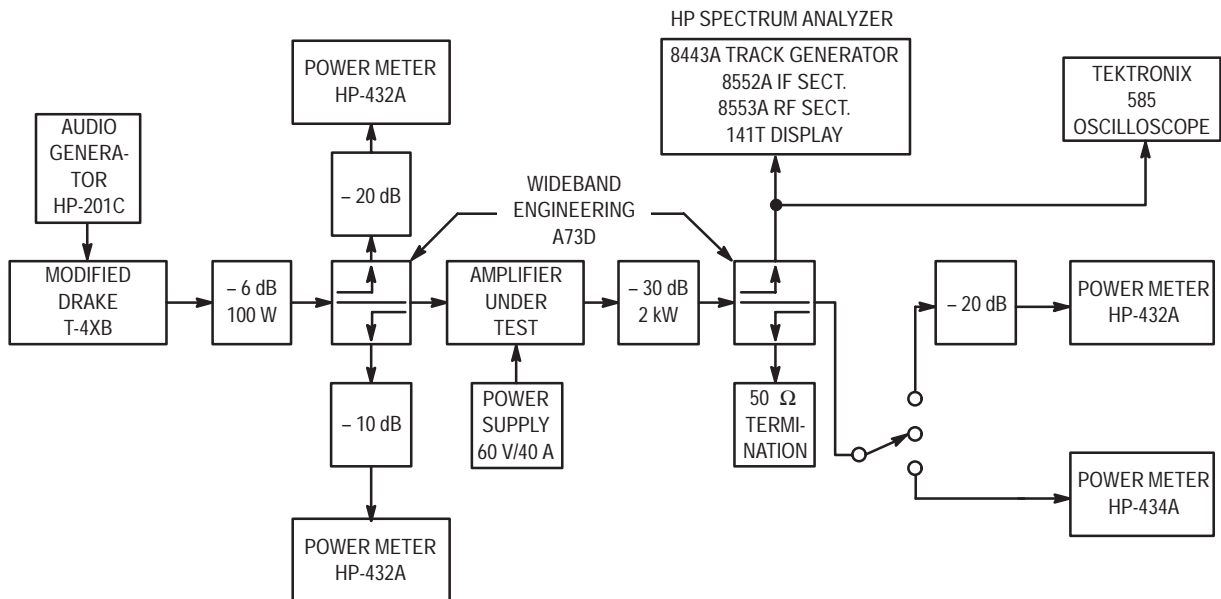

Figure 16. For two tone operation, a signal from an external audio oscillator is added to a signal from the T-4XB built-in oscillator, which has been adjusted to 800 Hz. During single tone testing, the external oscillator (1200 Hz) is switched off. A calorimeter wattmeter in the output can be used to calibrate the HP-432A's at frequencies below  $\approx 10$  MHz, where their response roll-off begins.

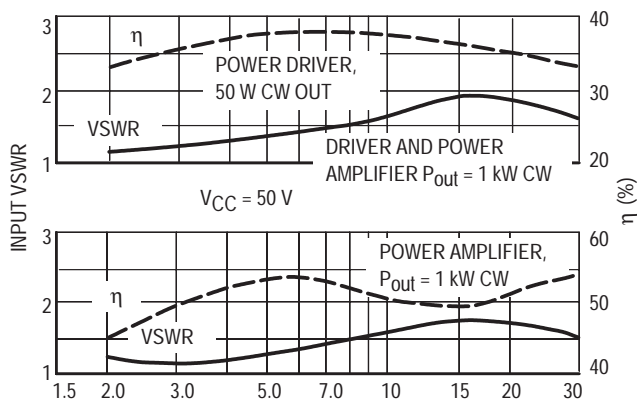

Figure 17. VSWR and Efficiency versus Frequency

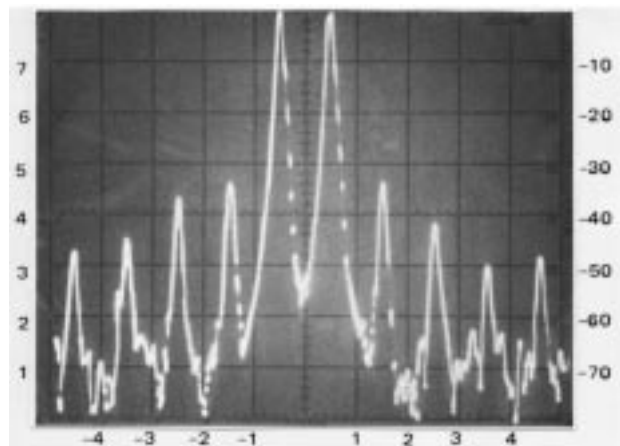

Figure 19. Photo of Spectrum Analyzer Display Showing the IMD Products to the 9th Order. Power Output = 1 kW at 30 MHz (50 V).

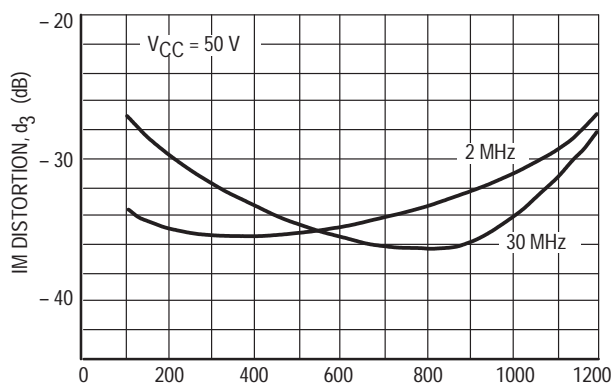

Figure 18. IMD versus Power Output

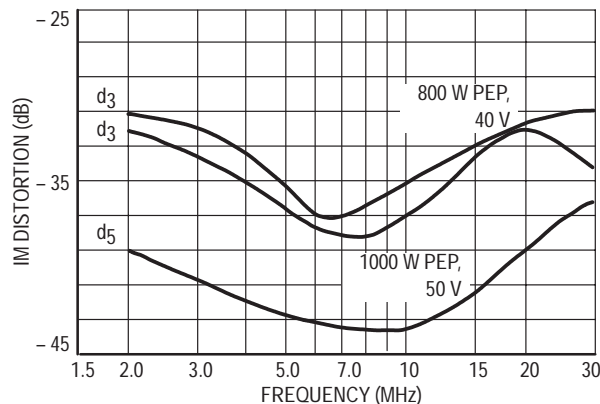

Figure 20. IMD versus Frequency

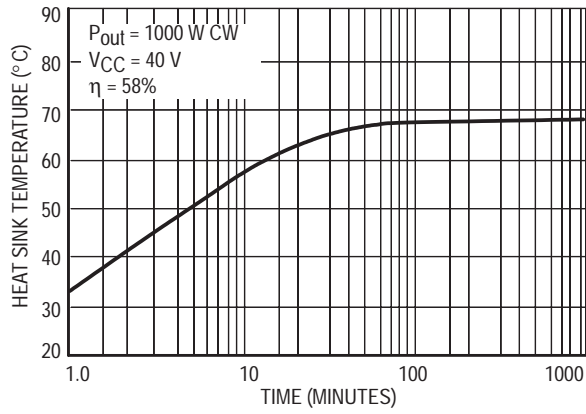

Figure 21. Heat Sink Temperature versus Time

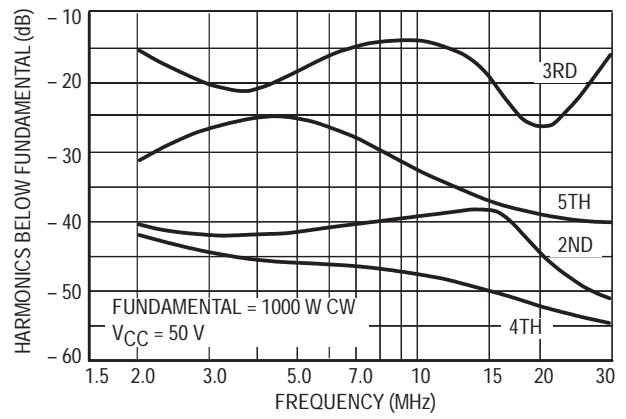

Figure 22. Output Harmonic Contents versus Frequency

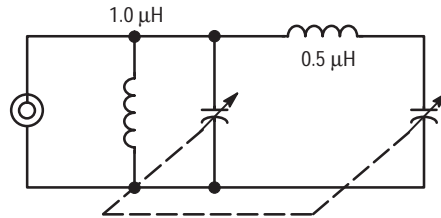
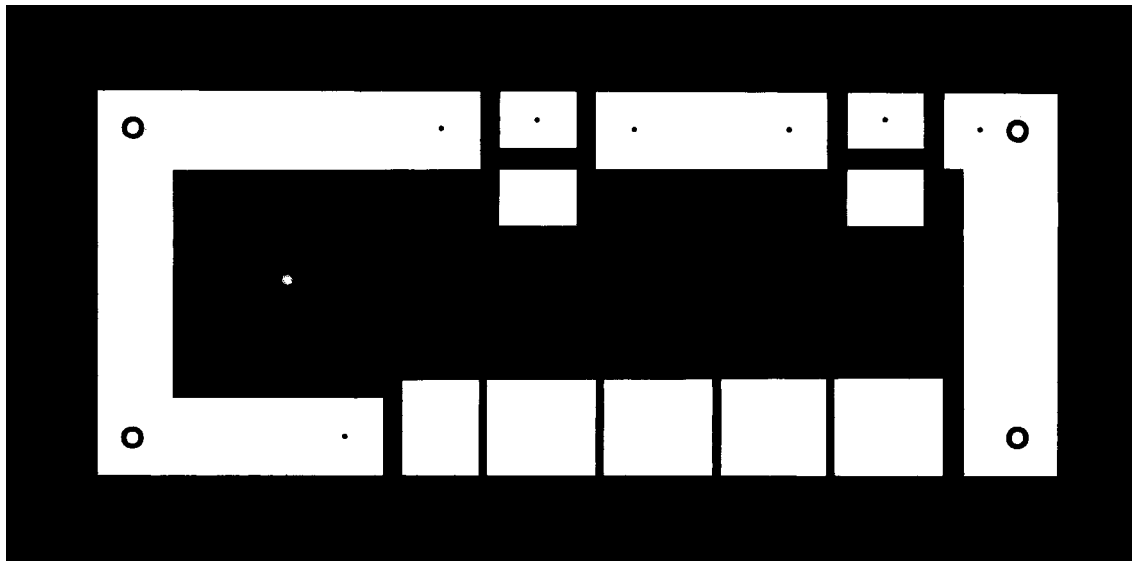

Figure 23. Load Mismatch Test Circuit



NOTE: Not to scale.

Figure 24. Circuit Board Layout of the Power Combiner Assembly



AN758

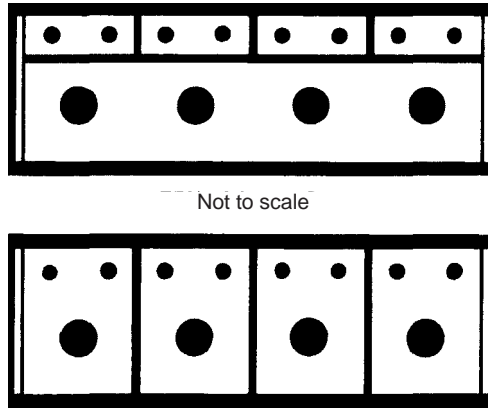

Figure 25. Board Layout of the Power Combiner Transmission Line Assembly

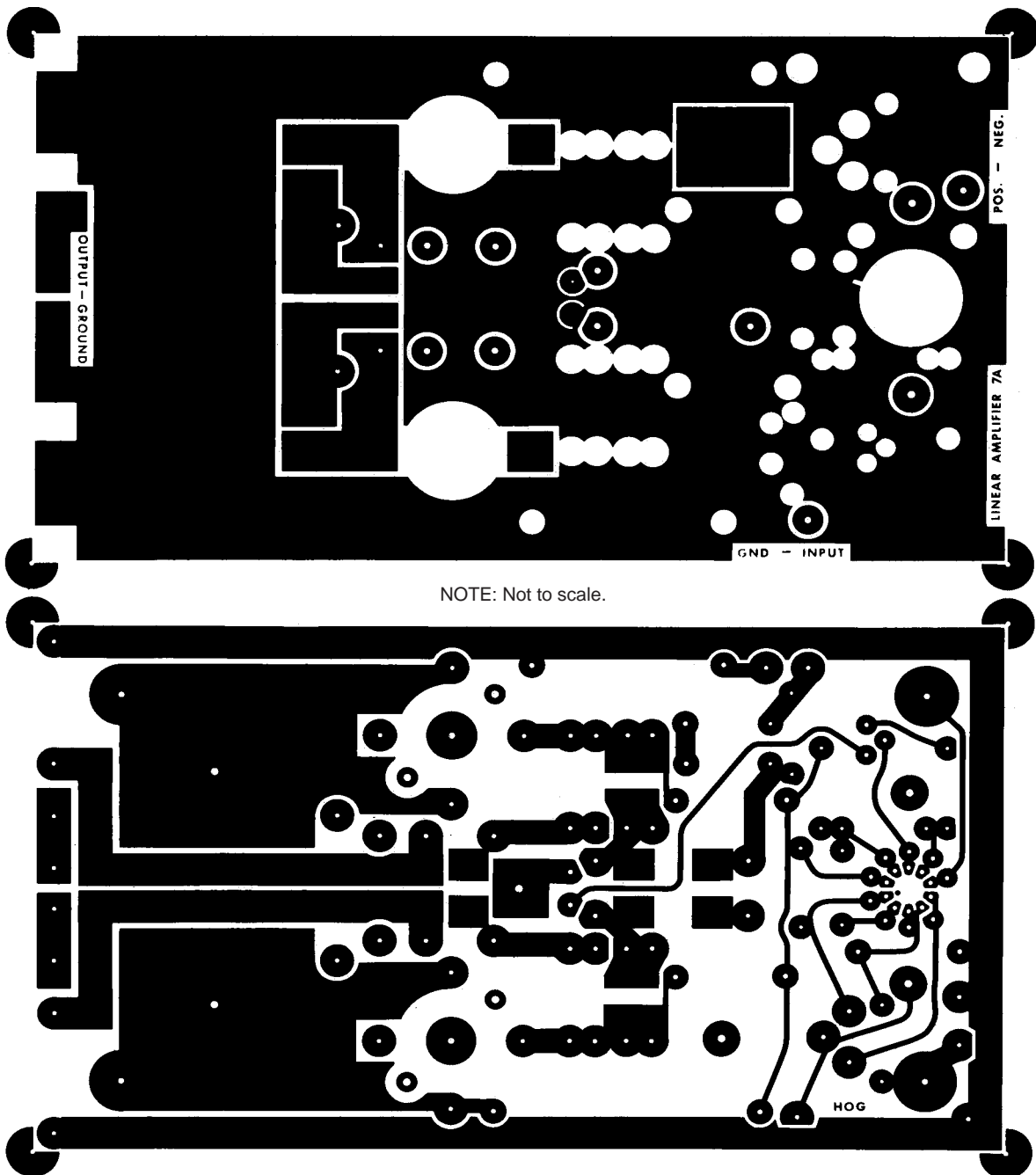



Figure 26. Board Layout of the 300 W Module and Driver Amplifier

## REFERENCES

1. Ruthroff: Some Broad Band Transformers, *IRE, Volume 47*, August 1975.
2. Lewis: *Notes on Low Impedance H.F. Broad Band Transformer Techniques*, Collins Radio Company, November 1964.
3. Granberg, H.: *Broadband Linear Power Amplifiers Using Push-Pull Transistors*, AN-593, Motorola Semiconductor Products Inc.
4. Granberg, H.: *Get 300 Watts PEP Linear Across 2 to 30 MHz From This Push-Pull Amplifier*, EB-27, Motorola Semiconductor Products Inc.
5. Granberg, H.: *Broadband Transformers and Power Combining Techniques for RF*, AN-749, Motorola Semiconductor Products Inc.
6. Hilbers: Design of H.F. Wideband Power Transformer Techniques, *Phillips Application Information #530*.
7. Pizalis-Couse: Broadband Transformer Design for RF Transistor Amplifiers, *ECOM-2989*, U.S. Army Electronics Command, Fort Monmouth, New Jersey, July 1968.
8. *Philips Telecommunication Review*, Volume 30, No. 4, pp.137–146, November 1972.
9. Hejhall, R.: *Solid-State Linear Power Amplifier Design*, AN-546, Motorola Semiconductor Products Inc.
10. Lefferson: Twisted Wire Transmission Line, *IEEE Transactions on Parts, Hybrids and Packaging*, Volume PHP-7, No.4, December 1971.
11. Krauss-Allen: Designing Toroidal Transformers to Optimize Wideband Performance, *ELECTRONICS*, August 1973.

Motorola reserves the right to make changes without further notice to any products herein. Motorola makes no warranty, representation or guarantee regarding the suitability of its products for any particular purpose, nor does Motorola assume any liability arising out of the application or use of any product or circuit, and specifically disclaims any and all liability, including without limitation consequential or incidental damages. "Typical" parameters can and do vary in different applications. All operating parameters, including "Typicals" must be validated for each customer application by customer's technical experts. Motorola does not convey any license under its patent rights nor the rights of others. Motorola products are not designed, intended, or authorized for use as components in systems intended for surgical implant into the body, or other applications intended to support or sustain life, or for any other application in which the failure of the Motorola product could create a situation where personal injury or death may occur. Should Buyer purchase or use Motorola products for any such unintended or unauthorized application, Buyer shall indemnify and hold Motorola and its officers, employees, subsidiaries, affiliates, and distributors harmless against all claims, costs, damages, and expenses, and reasonable attorney fees arising out of, directly or indirectly, any claim of personal injury or death associated with such unintended or unauthorized use, even if such claim alleges that Motorola was negligent regarding the design or manufacture of the part. Motorola and  are registered trademarks of Motorola, Inc. Motorola, Inc. is an Equal Opportunity/Affirmative Action Employer.

**Literature Distribution Centers:**

USA: Motorola Literature Distribution; P.O. Box 20912; Phoenix, Arizona 85036.

EUROPE: Motorola Ltd.; European Literature Centre; 88 Tanners Drive, Blakelands, Milton Keynes, MK14 5BP, England.

JAPAN: Nippon Motorola Ltd.; 4-32-1, Nishi-Gotanda, Shinagawa-ku, Tokyo 141, Japan.

ASIA PACIFIC: Motorola Semiconductors H.K. Ltd.; Silicon Harbour Center, No. 2 Dai King Street, Tai Po Industrial Estate, Tai Po, N.T., Hong Kong.

