

# BROADBAND LINEAR POWER AMPLIFIERS USING PUSH-PULL TRANSISTORS

Prepared by: **Helge Granberg**  
 RF Circuits Engineering

## INTRODUCTION

Linear power amplifier operation, as used in SSB transmitters, places stringent distortion requirements on the high-power stages. To meet these distortion requirements and to attain higher power levels than can be generally achieved with a single transistor, a push-pull output configuration is often employed. Although parallel operation can often meet the power output demands, the push-pull mode offers improved even-harmonic suppression making it the better choice. The exact amount of even-harmonic suppression available with push-pull stages is highly dependent on several factors, the most significant one being the matching between the two output devices. Nevertheless, even in the worst case the suppression provided in push-pull designs is superior to that of single-ended circuits. Device matching however is not limited to push-pull circuits since it is also required to a lesser degree in parallel transistor designs.

Two linear power amplifier designs are to be discussed in this Application Note. The 80 Watt design is intended for mobile communications systems operating from a 12.5 V power sources. The other supplies 160 W when operated from a 28 V line and it is intended for fix location systems. Both designs cover the 3 – 30 MHz band and utilize a driver stage to provide a total power gain of about 30 dB. Each amplifier requires some amount of heat-sinking for proper operation. The 28 V amplifier requires a heat-sink with a thermal characteristic of 0.85°C/W while the 12.5 V version uses a heat-sink with a 1.40°C/W thermal resistance. With these heat-sinks, cooling fans are not required for normal conditions, since with speech operation the average power is some 15 dB below peak levels. However, if two-tone bench testing is to exceed more than a duration of a few minutes, a cooling fan should be provided.

To assure ruggedness, engineering models of both amplifiers were subjected to open and short circuit output mismatches for several minutes at full power levels without any apparent damage to any of the transistors. This is very important in most equipment designs to avoid possible downtime for transistor replacements.

## A 28 V, 160 W AMPLIFIER

An amplifier which can supply 160 watts (PEP) into a 50 Ω load with IMD performance of – 30 dB or better is shown in the schematic diagram of Figure 1 and photos of Figures 2 and 3. Two 2N5942 transistors are employed in the design.

These transistors are specified at 80 watts (PEP) output with intermodulation distortion products (IMD) rated at – 30 dB. For broadband linear operation, a quiescent collector current of 60 – 80 mA for each transistor should be provided. Higher quiescent current levels will reduce fifth order IMD products, but will have little effect on third order products except at lower power levels. Generally, third order distortion is much more significant than the fifth order products.

A biasing adjustment is provided in the amplifier circuit to compensate for variations in transistor current gain. This adjustment allows control of the idling current for both the output and driver devices. This control is also useful if the amplifier is operated from a supply other than 28 volts.

Even with the biasing control, it is strongly suggested that the output transistors be beta matched. As with any push-pull design, both dc current gain and power gain at a midband frequency should be matched within about 15–20%. This matching may require more stringent limits if broad-banding is necessary since broad-band operation requires more effective cancellation of even harmonics. In the engineering model used, the transistors were not perfectly matched. Four “similar” pairs were selected from a total of ten randomly chosen 2N5942 transistors. Table 1 shows the measured harmonic suppression which is degraded by the mismatch in the output transistor parameters. This data was taken with a single frequency test and 80 watts average output.

**Table 1. Harmonic Suppression of 28 V Amplifier at Full Output Power**

| Harmonic  |        | 2nd     | 3rd     | 4th     | 5th     |
|-----------|--------|---------|---------|---------|---------|
| Frequency | 3 MHz  | – 16 dB | – 30 dB | – 22 dB | – 37 dB |
|           | 6 MHz  | – 15 dB | – 20 dB | – 21 dB | – 37 dB |
|           | 12 MHz | – 16 dB | – 24 dB | – 22 dB | – 34 dB |
|           | 30 MHz | – 35 dB | – 20 dB | – 51 dB | – 44 dB |

A 2N6370 transistor is employed as a driver. This device is specified – 30 dB IMD when delivering 10 watts (PEP). However, at about 4.5 W (PEP) output, which is the maximum necessary to drive two 2N5942 transistors, the IMD is typically better than – 40 dB with Class B biasing. A quiescent collector current level of at least 10 – 15 mA provides best IMD performance with the 2N6370. Higher current levels will not improve linearity, but will degrade driver efficiency.

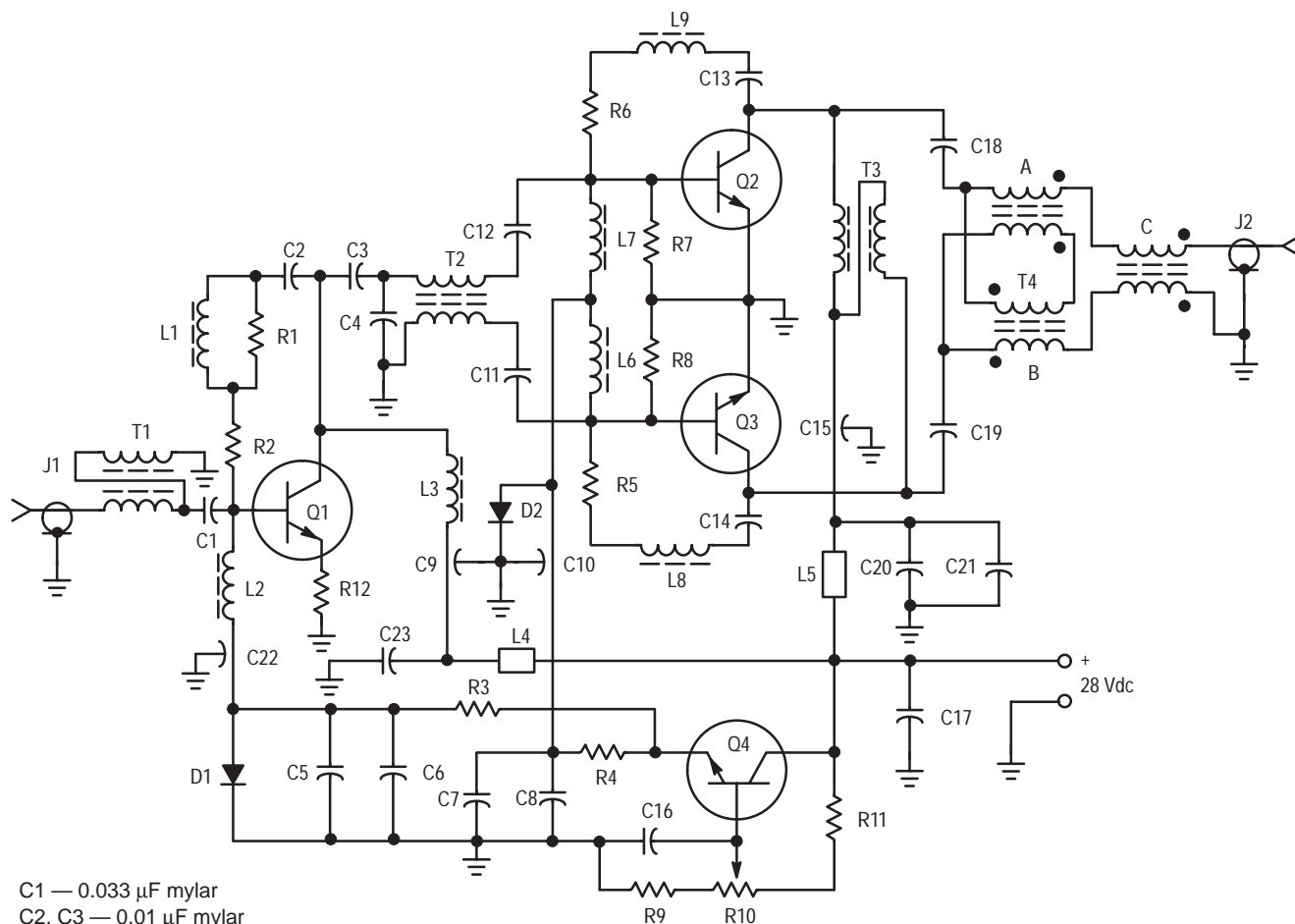

C1 — 0.033  $\mu$ F mylar  
 C2, C3 — 0.01  $\mu$ F mylar  
 C4 — 620 pF dipped mica  
 C5, C7, C16 — 0.1  $\mu$ F ceramic  
 C6 — 100  $\mu$ F/15 V electrolytic  
 C8 — 500  $\mu$ F/6 V electrolytic  
 C9, C10, C15, C22 — 1000 pF feed through  
 C11, C12 — 0.01  $\mu$ F  
 C13, C14 — 0.015  $\mu$ F mylar  
 C17 — 10  $\mu$ F/35 V electrolytic  
 C18, C19, C21 — Two 0.068  $\mu$ F mylars in parallel  
 C20 — 0.1  $\mu$ F disc ceramic  
 C23 — 0.1  $\mu$ F disc ceramic  
 R1 — 220  $\Omega$ , 1/4 W carbon  
 R2 — 47  $\Omega$ , 1/2 W carbon  
 R3 — 820  $\Omega$ , 1 W wire W  
 R4 — 35  $\Omega$ , 5 W wire W  
 R5, R6 — Two 150  $\Omega$ , 1/2 W carbon in parallel  
 R7, R8 — 10  $\Omega$ , 1/2 W carbon  
 R9, R11 — 1 k, 1/2 W carbon  
 R10 — 1 k, 1/2 W potentiometer  
 R12 — 0.85  $\Omega$ , (65.1  $\Omega$  or 43.3  $\Omega$  1/4  $\Omega$  resistors in parallel, divided equally between both emitter leads)

T1 — 4:1 Transformer, 6 turns, 2 twisted pairs of #26 AWG enameled wire (8 twists per inch)  
 T2 — 1:1 Balun, 6 turns, 2 twisted pairs of #24 AWG enameled wire (6 twists per inch)  
 T3 — Collector choke, 4 turns, 2 twisted pairs of #22 AWG enameled wire (6 twists per inch)  
 T4 — 1:4 Transformer Balun, A&B — 5 turns, 2 twisted pairs of #24 AWG, C — 8 turns, 1 twisted pair of #24 AWG enameled wire (All windings 6 twists per inch). (T4 — Indiana General F624-19Q1 — All others are Indiana General F627-8Q1 ferrite toroids or equivalent.)

#### PARTS LIST

|                                       |                         |
|---------------------------------------|-------------------------|
| L1 — .33 $\mu$ H, molded choke        | Q1 — 2N6370             |
| L2, L6, L7 — 10 $\mu$ H, molded choke | Q2, Q3 — 2N5942         |
| L3 — 1.8 $\mu$ H, (Ohmite 2-144)      | Q4 — 2N5190             |
| L4, L5 — 3 ferrite beads each         | D1 — 1N4001             |
| L8, L9 — .22 $\mu$ H, molded choke    | D2 — 1N4997             |
|                                       | J1, J2 — BNC connectors |

Figure 1. 160 Watt (PEP) Broadband Linear Amplifier

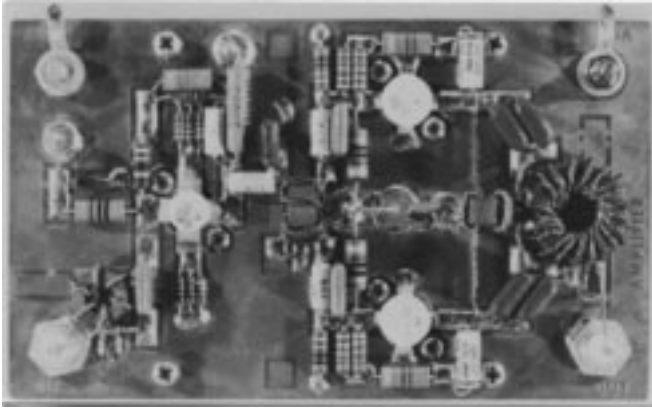

Figure 2. Photo of 28 V Linear Amplifier

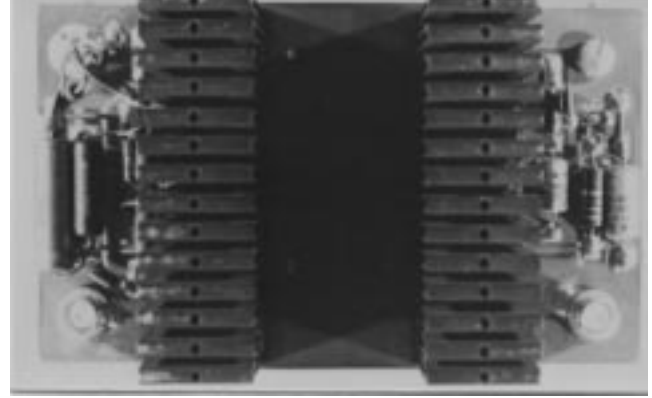
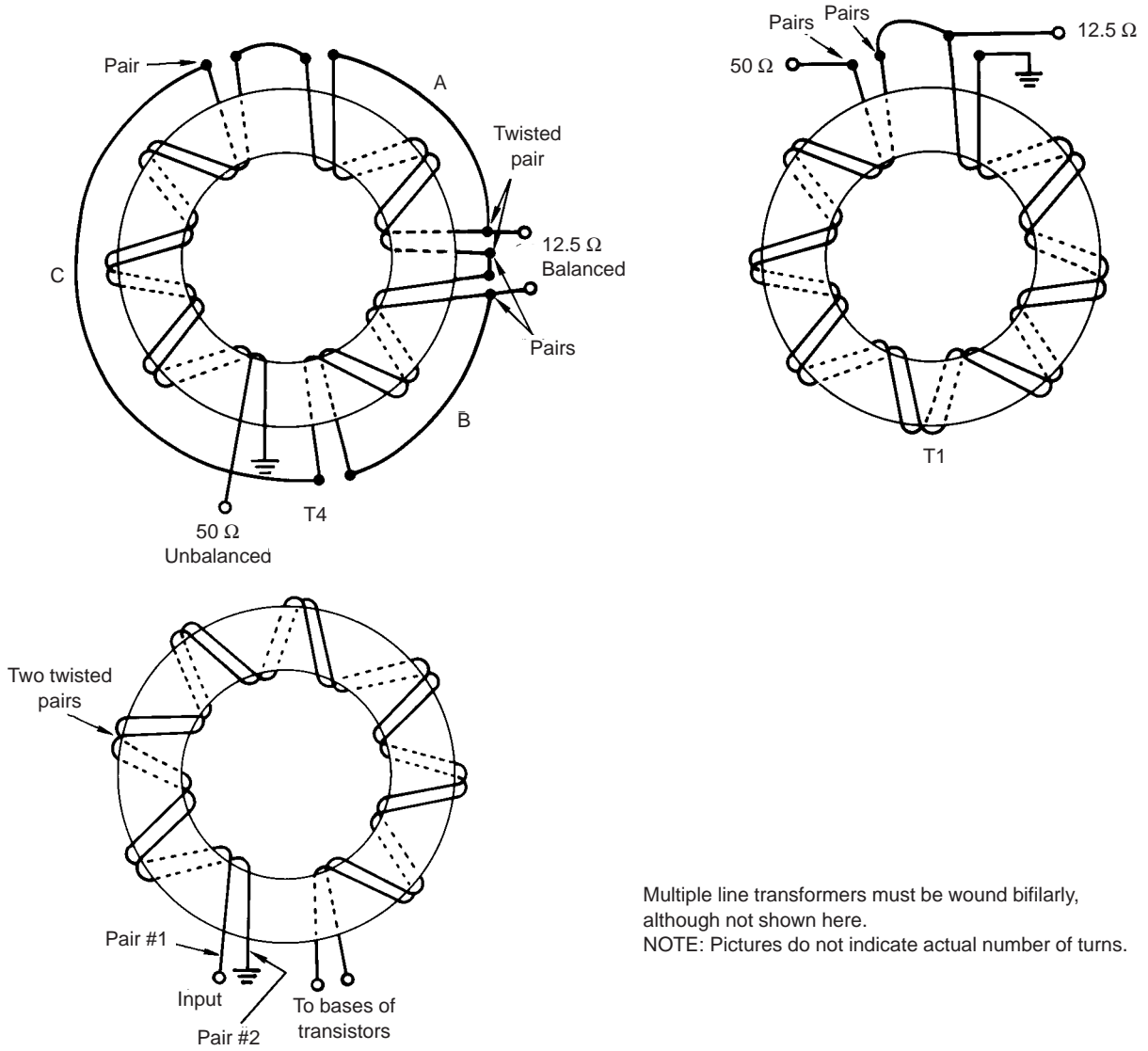

Figure 3. Photo of Back Side of 28 V Linear Amplifier



Multiple line transformers must be wound bifilarly, although not shown here.  
NOTE: Pictures do not indicate actual number of turns.

Figure 4. Transformer Details for 28 V Linear Amplifier

**Feedback**

To compensate for variations in output with changes in operating frequency, negative voltage feedback is employed on both the final amplifier and driver stages. At the low end of the desired frequency band, approximately 4.5 dB of feedback is introduced in the final stage and 15 dB in the driver stage. With this feedback and the feedback networks shown in the schematic diagram, Figure 1, a total gain variation of 0.5 dB was measured on an engineering prototype amplifier over a 3 – 30 MHz range. The total gain differential in three identical amplifiers constructed for evaluation was less than 1.5 dB.

**Transformers Employed**

In order to achieve the desired broadband response, transmission line-type transformers were employed for coupling and signal-splitting. These transformers utilize twisted-pair windings and toroidal cores. Transformers T1, T2 and T3 have turn ratios of 4:1, 1:1 and 1:4 respectively. Additional information on these transformers can be found in the references. A short description of each of the transformers will follow.

**Transformer T1** provides an impedance transformation to match the 50 Ω source to the low impedance level required at the base of Q1. This transformer consists of six turns of two twisted pairs wound on a toroidal core. The two pairs (four separate wires), are twisted together and the two wires from each original pair are soldered together at each end. Each pair thus connected is shown as a single wire in Figure 4. The pairs can easily be identified by choosing wires with two different colors of insulation.

**Transformer T2** is a 1:1 Balun consisting of six turns of two-twisted pairs of wire (four wires total). As shown in Figure 4 each of the pairs is treated as a single wire.

**Transformer T3** consists of four turns of two twisted pairs. Again both wires of each pair are soldered together at each end.

**Transformer T4** is a 1:4 ratio unbalanced to balanced unit with three separate windings.

A lumped-constant equivalent conventional transformer diagram of transformer T4 is shown in Figure 5. The two windings in a single twisted pair are indicated by similar capital and lower case letters (i.e. windings A and a). The output line of the balun is in the same direction as windings A and B while the grounded line is in the opposite direction from the winding it is connected to. Windings A, a, B and b consist of 5 turns of two twisted pairs while C and c are formed from eight turns of a single pair. Connections are shown in Figure 4. The three windings are bifilar wound, although for simplicity the figures do not show this.

Referring to Figure 5 the equivalent connection diagram of T4, it can be seen that the sum of the voltages across c and C should be equal to the voltage across windings DE. From this, winding cC (a twisted pair) should have twice as many turns as twisted pairs aA and bB. Deviations of about 10 – 20% from the 2:1 ratio do not produce noticeable effects.

The ferrite core used for T4 in the parts list of Figure 1 has a specified maximum flux density of about 100 gauss. The flux density may be computed from equation 1.

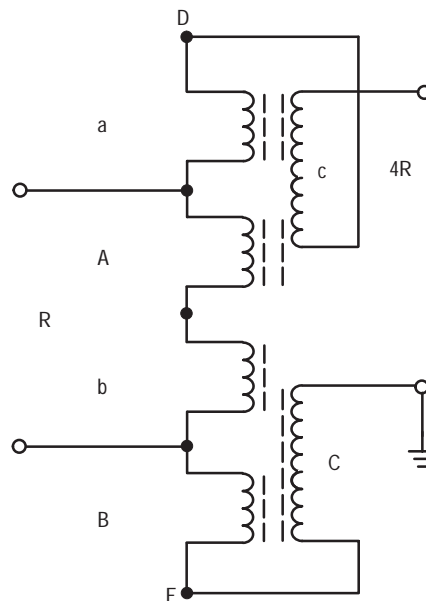

**Figure 5. Equivalent Lumped Element Form of T4**

$$B_{max} = \frac{V \times 10^8}{4.44 \text{ fnA}} \text{ gauss} \tag{1}$$

- where V = RMS voltage across the winding = 89
- f = frequency in Hertz =  $3 \times 10^6$
- n = number of turns (windings Aa and Bb only. Windings Cc cancel each other) = 20
- A = cross sectional area of Toroid in  $\text{cm}^2 = 0.25$
- 4.44 =  $2\pi \times 0.707$

therefore:

$$B_{max} = \frac{89 \times 10^8}{4.44 (3 \times 10^6) 20 (.25)} = 133 \text{ gauss}$$

Despite this slight overrating, this density is not excessive.

**Amplifier Performance**

The data shown in the following curves was obtained from measurement performed on an engineering model of the 28 V 160 Watt (PEP) amplifier.

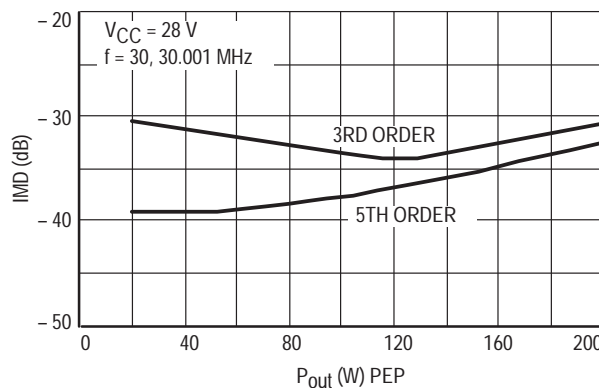

**Figure 6. IMD as a Function of Output Power for 28 V Amplifier**

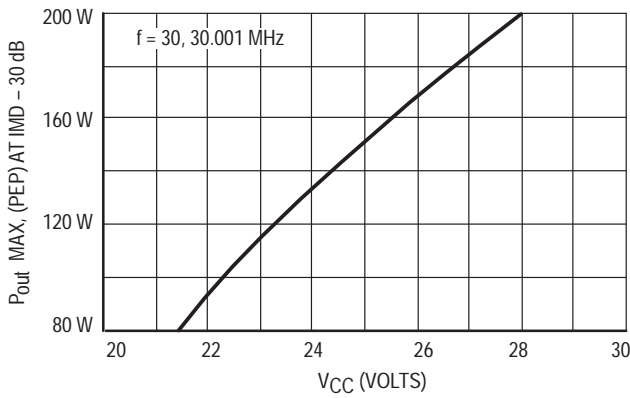

Figure 7. Output Power for – 30 dB IMD as a Function of VCC for 28 V Amplifier

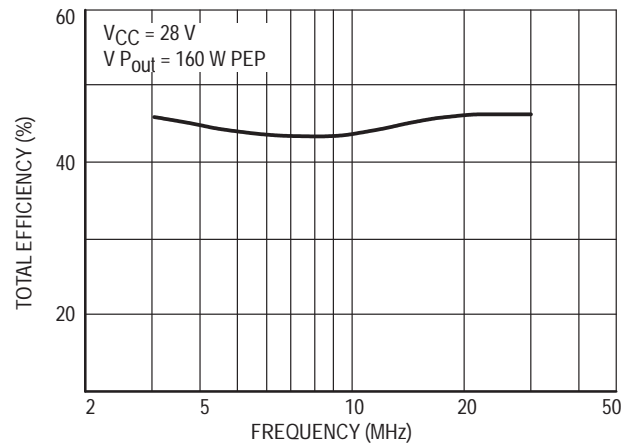

Figure 10. Total Efficiency versus Frequency

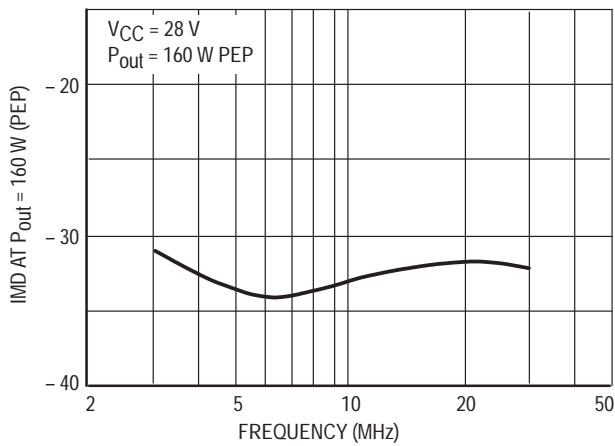

Figure 8. IMD versus Frequency

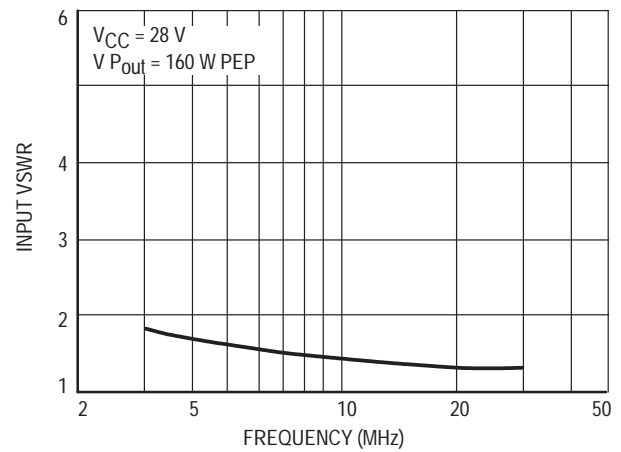

Figure 11. VSWR versus Frequency

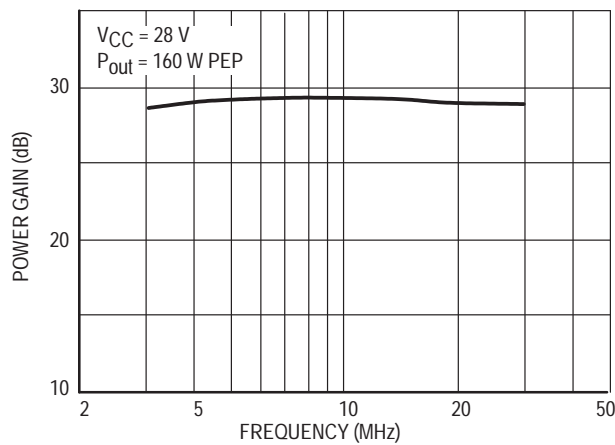

Figure 9. Power Gain versus Frequency

### AN 80 WATT (PEP) 12.5 – 13.6 V AMPLIFIER

To complement the 28 Volt amplifier discussed previously, a second amplifier designed for 12 V operation was constructed and evaluated. This amplifier is shown in Figures 12, 13 and 14. It utilizes a 2N6367 and a pair of 2N6368 transistors. The 2N6367 transistor is employed as a driver and is specified for up to 9 watts (PEP) output. In the amplifier design the driver must supply only 5 watts (PEP) at 30 MHz with a resulting IMD performance of about – 37 to – 38 dB. At lower operating frequencies, drive requirements drop to the 2 – 3 Watt (PEP) range and IMD performance improves to better than 40 dB. The 2N6367 data sheet suggests a quiescent collector current of 35 mA, but it was found that increasing this to 40 mA yielded somewhat better linearity in broadband operation.

Two 2N6368 transistors are employed in the final stage of the transmitter design in a push-pull configuration. These devices are rated at 40 Watts (PEP) and – 30 dB maximum IMD, although – 35 dB performance is more typical for narrow band operation.

The 2N6368 data sheet suggests a quiescent collector current level of 50 mA, but a level of 60 mA for each transistor was used in this design for improved linearity.

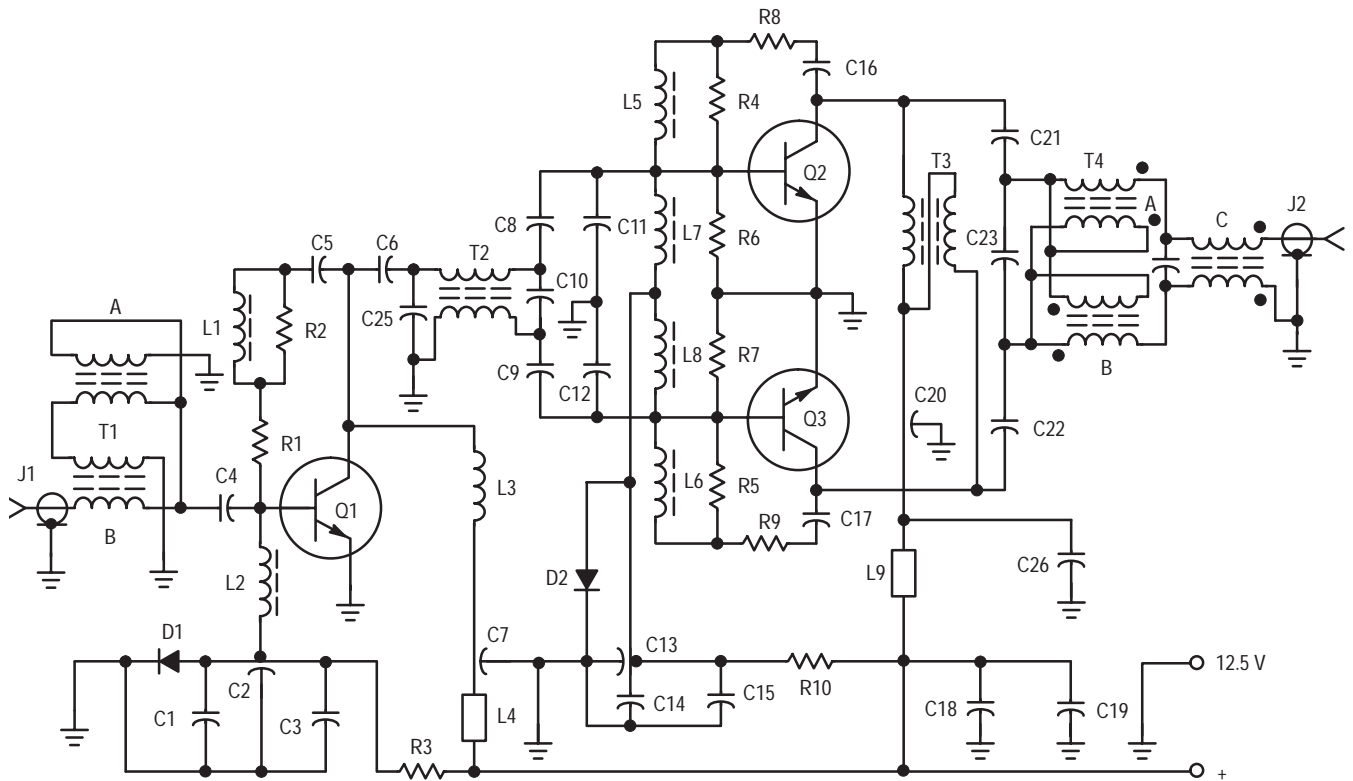

C1, C14, C18 — 0.1  $\mu\text{F}$  ceramic  
 C2, C7, C13, C20 — 0.001  $\mu\text{F}$  feed through  
 C3 — 100  $\mu\text{F}/3\text{ V}$   
 C4, C6 — 0.033  $\mu\text{F}$  mylar  
 C5 — 0.0047  $\mu\text{F}$  mylar  
 C8, C9 — 0.015 and 0.033  $\mu\text{F}$  mylars in parallel  
 C10 — 470 pF mica  
 C11, C12 — 560 pF mica  
 C15 — 1000  $\mu\text{F}/3\text{ V}$   
 C16, C17 — 0.015  $\mu\text{F}$  mylar  
 C19 — 10 pF 15 V  
 C21, C22 — Two 0.068  $\mu\text{F}$  mylars in parallel  
 C23 — 330 pF mica  
 C24 — 39 pF mica  
 C25 — 680 pF mica  
 C26 — .01  $\mu\text{F}$  ceramic  
 R1, R6, R7 — 10  $\Omega$ , 1/2 W carbon  
 R2 — 51  $\Omega$ , 1/2 W carbon  
 R3 — 240  $\Omega$ , 1 wire W  
 R4, R5 — 18  $\Omega$ , 1 W carbon  
 R8, R9 — 27  $\Omega$ , 2 W carbon  
 R10 — 33  $\Omega$ , 6 W wire W

T1 — 2 twisted pairs of #26 wire, 8 twists per inch, A = 4 turns  
 B = 8 turns. Core — Stackpole 57-9322-11, Indiana General F627-8Q1 or equivalent.  
 T2 — 2 twisted pairs of #24 wire, 8 twists per inch, 6 turns  
 (Core as above.)  
 T3 — 2 twisted pairs of #20 wire, 6 twists per inch, 4 turns  
 (Core as above.)  
 T4 — A and B = 2 twisted pairs of #24 wire, 8 twists per inch.  
 5 turns each. C = 1 twisted pair of #24 wire, 8 turns.  
 Core — Stackpole 57-9074-11, Indiana General F624-19Q1  
 or equivalent.  
 L1 — 0.22  $\mu\text{H}$ , molded choke  
 L2, L7, L8 — 10  $\mu\text{H}$ , molded choke  
 L5, L6 — 0.15  $\mu\text{H}$   
 L3 — 25 t, #26 wire, wound on a 100  $\Omega$ , 2 W resistor (1.0  $\mu\text{H}$ )  
 L4, L9 — 3 ferrite beads each  
 Q1 — 2N6367  
 Q2, Q3 — 2N6368  
 D1 — 1N4001  
 D2 — 1N4997  
 J1, J2 — BNC connectors

Figure 12. Schematic Diagram of 12.5 V Amplifier

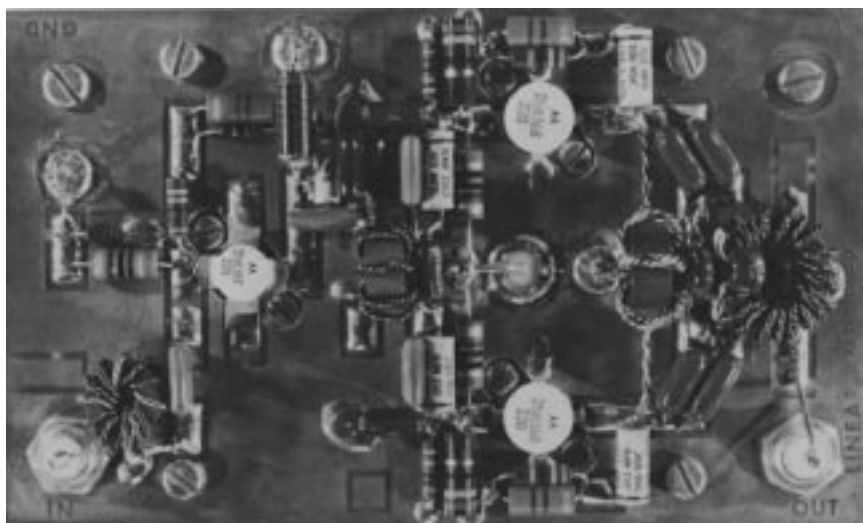

Figure 13. Photo of Top View of 12.5 V Linear Amplifier

Without frequency compensation, the completed amplifier can deliver 90 Watts (PEP) in the 25 – 30 MHz band with IMD performance down – 30 dB. If only the power amplifier stage is frequency compensated, 95 Watts (PEP) can be obtained at 6 – 10 MHz.

### Gain Compensation

Negative collector-to-base feedback is employed in both the driver and output stages for gain compensation. The feedback networks consist of: a) a dc blocking capacitor, b) a series resistor, to limit the amount of feedback at the low frequencies and c) a series inductor with a parallel resistor to determine the feedback slope.

In general, the use of negative feedback lowers the input impedance, and reduces the gain of the amplifier. However, it also improves the linearity since some of the output signal is fed back to the input and reamplified, tending to cancel the distortion originally generated. This is only true at the low frequencies where the phase errors are small. The phase error is caused by reactive elements in the feedback path. Since the basis for the compensation is to introduce more feedback at low frequencies, it will also equalize the input impedance to some degree. This, in turn, should result in a lower VSWR over the band.

The following two tables illustrate the affect of compensation on the final amplifier stage. This data was taken with a 9:1 ratio transformer connected between 50  $\Omega$  source and the input balun to the final stage.

From this table it can be seen that efficiency is reduced by applying compensation. For this reason only 3 dB of compensation was utilized on the final stage. The driver stage, where efficiency is not of primary concern, was actually over compensated. This stage has a gain of 16 dB at 30 MHz but only 13 dB at 3 MHz.



Figure 14. Photo of Bottom of 12.5 V Linear Amplifier

Table 2. Performance of 12.5 V Output Stage With and Without Gain Compensation

| With Feedback    |         |       |         |      |
|------------------|---------|-------|---------|------|
|                  | GPE     | EFF.  | IMD     | VSWR |
| 3 MHz            | 16 dB   | 45.5% | – 30 dB | 1.6  |
| 12 MHz           | 15.3 dB | 46.5% | – 31 dB | 2.1  |
| 30 MHz           | 12 dB   | 43.0% | – 31 dB | 1.05 |
| Without Feedback |         |       |         |      |
|                  | GPE     | EFF.  | IMD     | VSWR |
| 3 MHz            | 19.2 dB | 48.0% | – 26 dB | 6.5  |
| 12 MHz           | 16.2 dB | 46.8% | – 30 dB | 2.4  |
| 30 MHz           | 12.5 dB | 43.0% | – 33 dB | 1.05 |

**Transformer T1** consists of two twisted pairs of wires which can be wound on either a single or two separate toroids. In the two core approach, both windings have an equal number of turns (four). If a single core is utilized, winding Aa uses four turns while winding Bb uses eight turns. These lines must be wound bifilar on the core. See Figure 15. The single core approach was used in the engineering model.

A lumped-constant equivalent conventional transformer diagram of transformer T1 is shown in Figure 16. Examination reveals that since winding B is directly in parallel with the series combination of aA, line Bb must have twice the number of turns as winding Aa. (The lower case and capital letters refer to the two wires in a given twisted-pair). As an example of the voltage relationships for the various windings in this transformer, an arbitrary 3 V input has been shown in the Figure. It can be seen that the voltages generated across windings b and B are out of phase and

cancel each other. Therefore, the resulting output is 1 V (3 V – 2 V).

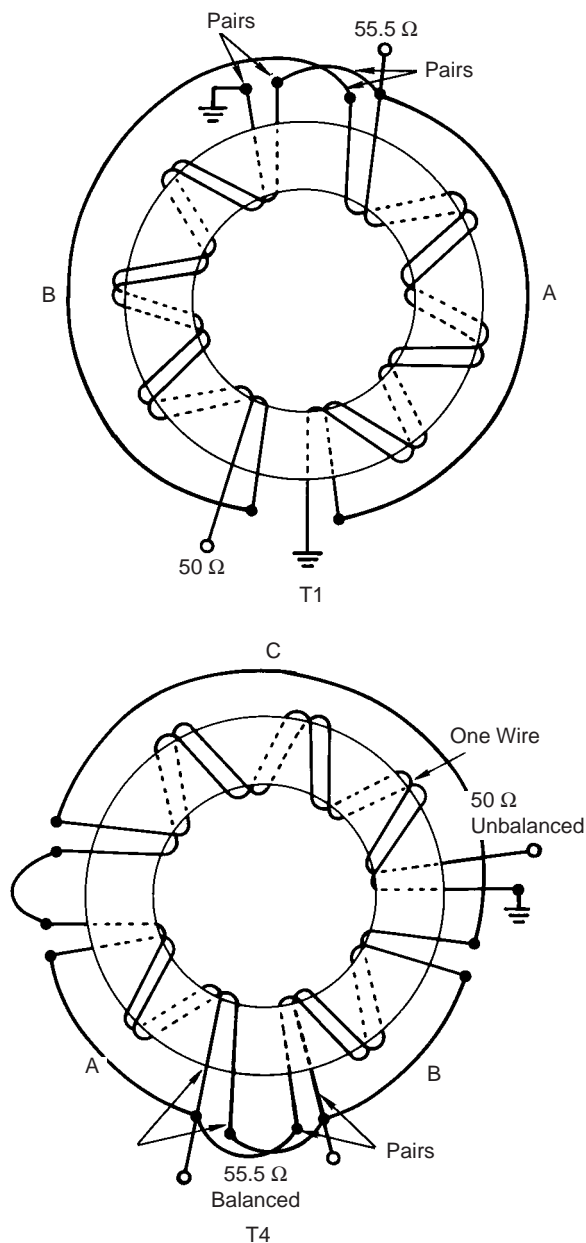

Figure 15. Transformer Details for 12.5 V Linear Amplifier (see Figure 4)

This transformer may be considered as a combination of a 4:1 ratio transformer (aA) and a 1:1 balun (bB), where the balun performs the voltage subtraction.

**Transformer T2** consists of two twisted pairs on a single core. Both wires of each pair are soldered together at each end. See Figure 15.

**Transformer T3** also uses two twisted pairs wound on a single core. Each pair is treated as a single wire by soldering the two wires at each end.

**Transformer T4** uses three separate bifilar windings on a single core. Windings aA and bB are balanced while Cc is unbalanced. Both aA and bB utilize five turns and Cc uses eight turns. This is the nearest whole number of turns possible to the desired ratio of 1:1.5 for winding Aa and Bb to winding cC. Deviations of 10 – 20% of this ratio are allowable without noticeable effects.

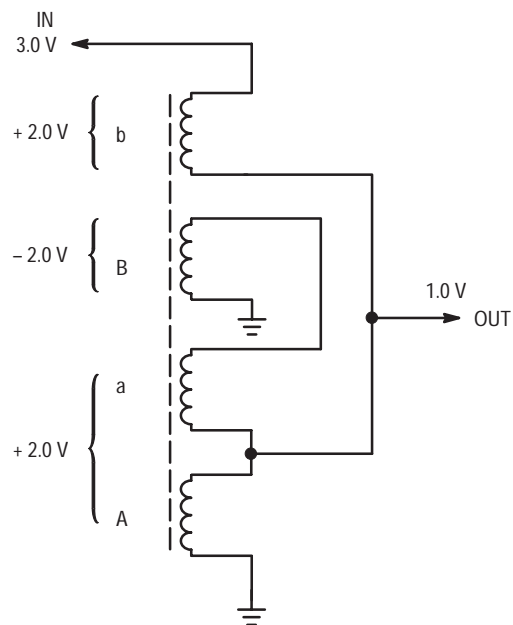

Figure 16. Equivalent Lumped Element Form of T1

Figure 17 shows the lumped equivalent transformer of T4 and the ratio of voltages on the various windings if one volt is applied to the input. It can be seen that the voltage developed across c and C must equal the voltage between points D and E on the diagram. Since windings A and b are paralleled and connected to the input, they see one volt. Thus the voltage from point D to point E would be 3 V (1 V from A and b plus 1 V from winding a plus 1 V from winding B). Therefore, the output voltage is 3.0 volts and the voltage across winding c = – 1.5 V and winding C = 1.5 V.

When using twisted-pair transmission line transformers, windings with four or more pairs should be avoided as it is difficult to twist such lines uniformly.

A second amplifier was evaluated with T4 replaced by a balun and an unsymmetrical 1:9 ratio transformer. Performance results were very similar to that obtained from the first version except that much more high frequency compensation was necessary. This was required because it is difficult to obtain the low characteristic impedance required for the balun. For this reason capacitors C10, C11, C12 and C25 were unusually large in value.



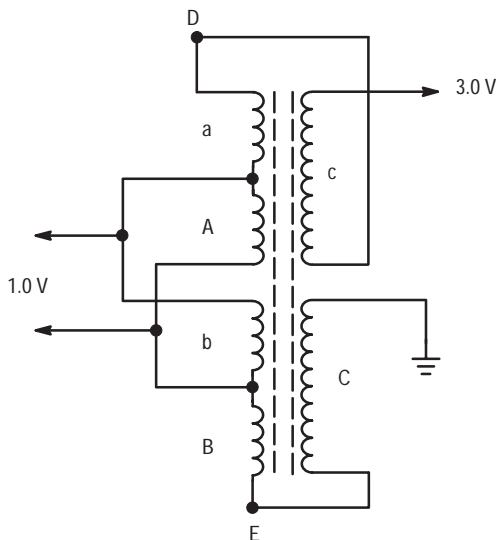

Figure 17. Equivalent Lumped Element Form of T4

**Performance**

Typical performance of the 12.5 volt linear amplifiers is provided in the following curves. A calibration curve for use to correlate low frequency readings on a power meter is also given in Figure 24.

The harmonic suppression measurements taken at full output power levels with a single tone test are illustrated in Table 2. This data suggests that a suitable low-pass filter between the amplifier output and the antenna will be required to meet harmonic suppression requirements. This filter's necessity is common to most broadband amplifier designs.

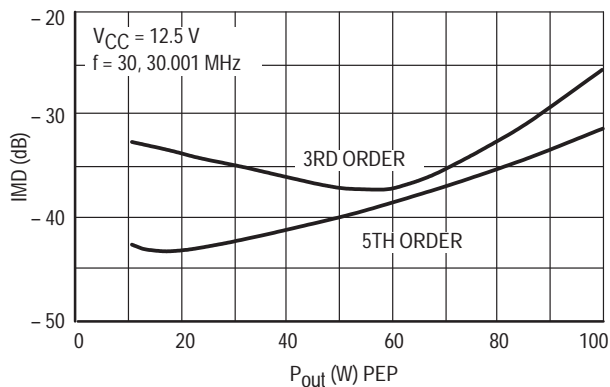

Figure 18. EMD as a Function of Output Power for Push-Pull Linear Amplifier

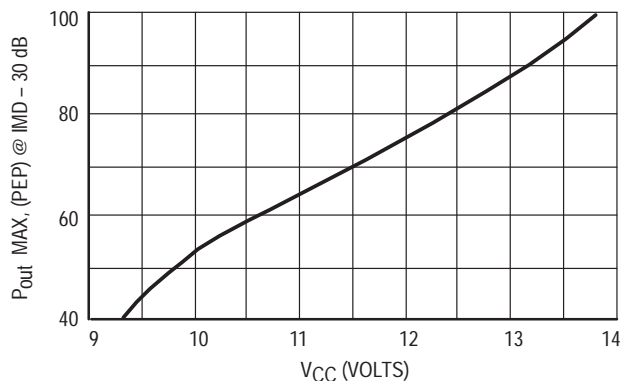

Figure 19. Maximum Output Power @ - 30 dB IMD versus V<sub>CC</sub> for 12.5 V Power Amplifier

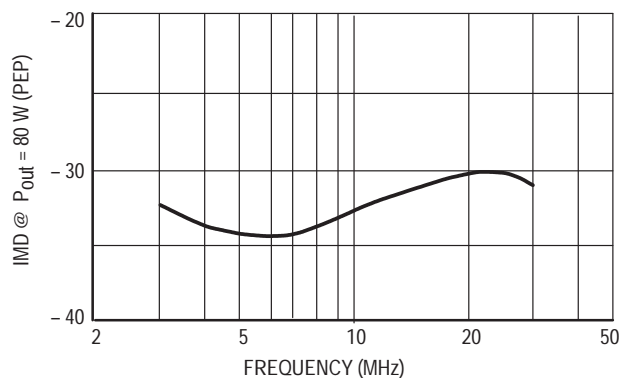

Figure 20. IMD versus Frequency

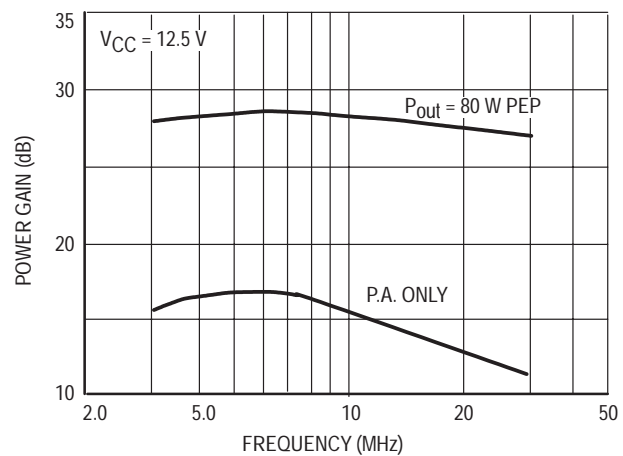

Figure 21. Power Gain versus Frequency

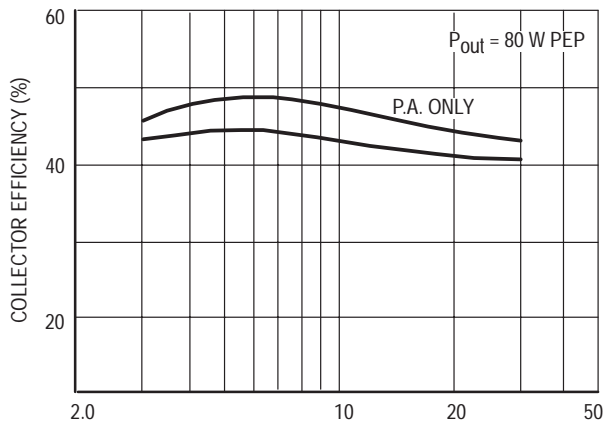

Figure 22. Efficiency versus Frequency

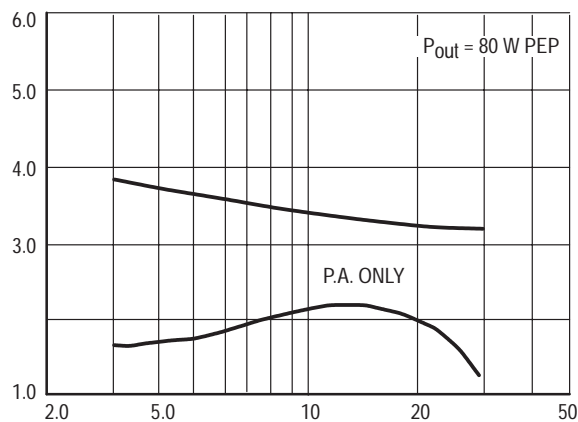

Figure 23. VSWR versus Frequency

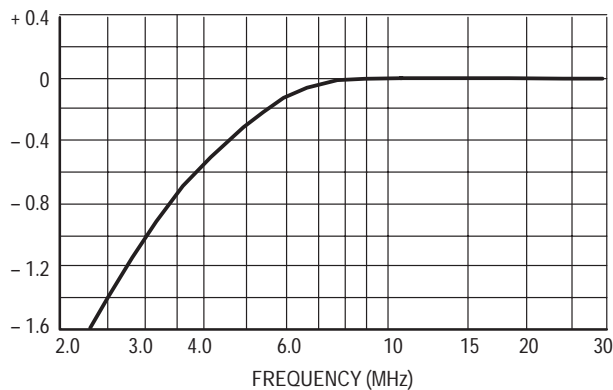

Figure 24. Response of H.P. 431 – 432 Power Meters at Low Frequencies

### Transformer Data

As with the 28 V amplifier, transmission line type transformers are employed throughout the 12 V design. Although this type of transformer does not provide optimum impedance match, it is easy to duplicate for consistent performance results. A similar amplifier was constructed with a standard 2:1 ratio coupling transformer instead of the 1:1

ratio balun (T2). This amplifier featured a 40 – 60% improvement in VSWR at all frequencies while gain and IMD were basically unchanged from the performance of the model using transmission line type transformers.

Splitting the compensating capacitor for transformer T2 into three parts (C10, C11 and C12) will result in considerably lower IMD at higher frequencies. Capacitors C11 and C12 should be well matched and therefore should be either  $\pm 5\%$  or better tolerance fixed value units, or variable capacitors such as Arco 466 and 469.

Two factors must be considered in the choice of toroidal core materials. The first is core losses. The second is the power handling capability which is limited by both magnetic saturation and heat generation.

For the input transformer (T1) core losses are of primary concern. For the material chosen in this design, a loss factor of 1 – 2 mW/cm<sup>3</sup> at 3 MHz is typical. This increases to 5 – 10 mW/cm<sup>3</sup> at 30 MHz. For the size of core used in T1, a maximum core loss of 1.5 – 7.0 mW can be expected. While this figure seems negligible, it is advantageous to use the smallest practical sized core for the input transformer consistent with the wire size and required number of turns.

Conversely the core of the output transformer (T4) should be as large as possible to be able to handle the required power levels and remain in the linear operating region of the materials' B-H curve. If the core is operated near the saturation region of the core material, distortion will be generated on the carrier and envelope. This saturation occurs first at low frequencies. However, core heating due to losses is most prevalent at higher frequencies, being a function of flux density and operating frequency. The maximum recommended flux density for a 1/2" O.D. toroid (such as Indiana General F627-8 or Stackpole 57-9322), is 45 to 70 gauss. From the B-H curves it can be seen that this is well into the linear region.

For the 12-volt amplifier, a flux density of roughly 180 gauss would be required for a 1/2" O.D. core. Use of a larger core reduces the density to about 130 gauss. As stated in the 28 V amplifier section, although this is in excess of the 100 gauss limit suggested for the particular core type, it was not found to be excessive. In fact, some of the 1/2" O.D. toroids were tested at three to four times the maximum recommended flux density, and then compared to a larger toroid of the same material. The distortion in each core was small enough not to be noticed in an oscilloscope. However, there was some amount of heat generated in the small toroid at the high frequencies. Excessive heating is the primary problem that one should be first concerned about.

As a rule of thumb, the required minimum transformer inductance can be determined to have at least 4 – 5 times the reactance of the high impedance port at the lowest operating frequency. This means that for T4, the reactance would be 250 ohms, which corresponds to roughly 14  $\mu$ H at 3 MHz.

Employing a different wire size or wire with a different thickness of dielectric or changing the number of twists per inch will alter the line impedance. However, this is one of the least critical points in the design of broadband linear amplifiers and will mainly affect the amount of high frequency compensation required. The variations in the transistor input and output impedance over a decade frequency range are several times larger than the changes in transformer impedance due to wire sizes or twist variations. Although

compromises in matching are necessary to tune the wide frequency range, they are most serious in the output stage where a mismatch can significantly degrade total linearity.

The maximum theoretical linear output powers for the 28 V and 12.5 V amplifiers would be 120 W and 50 W respectively, when 4:1 and 9:1 output transformers are employed.

However, due to stray inductances in the circuit, and line impedances usually being higher than optimum, the actual impedance ratios of the transformers will be somewhat higher.

Thus, if the phase and even harmonic distortions are minimized it is possible to obtain higher power levels with fairly low IMD readings despite slight flat-topping of the envelope.

### Construction Notes (12.5 V Version)

The circuit board for both amplifier designs is made of two-sided copper-fiberglass laminate. A full sized pattern is given in Figures 25 and 26. The ground planes on each side are connected together at several points with the feedthrough capacitors, the BNC connectors and the mounting screws. From experience with an earlier broadband amplifier, it was learned that a good ground plane is extremely important because of the high currents and low impedance levels involved. The power supply impedance must be as low as possible.

The ac impedance of the supply should not be higher than 0.01 ohm at the lowest envelope frequency.

All dc connections are made on the back side of the board which is separated from the heat sink by 3/32 inches. The base bias resistors (R3, R10), and all by-pass capacitors, except the feed-throughs, are on the back side of the board in each end of the heat sink. Diode D2 is press fitted into the heat sink for temperature compensation of the quiescent collector currents of the 2N6368 transistors. Ceramic capacitors have been avoided, except for certain by-pass applications, because they have spurious resonances and, their capacitance values are voltage and temperature sensitive. Parallel capacitors are employed to increase the current carrying capability and to decrease the possibility of self resonances. The peak RF current in the output transformer primary is

$$\sqrt{\frac{80 \text{ W}}{6.25 \Omega}} = 3.54 \text{ A.}$$

Half of this is supplied by each 2N6368. Thus, the collector isolation capacitors will have to handle 1.77A peak and 1.26A average currents. Even the lead sizes in most capacitors are insufficient for these current levels. In general, the low impedances involved in a 12.5 volt amplifier of this power level make the layout, construction and component selection somewhat critical compared to a higher voltage unit.

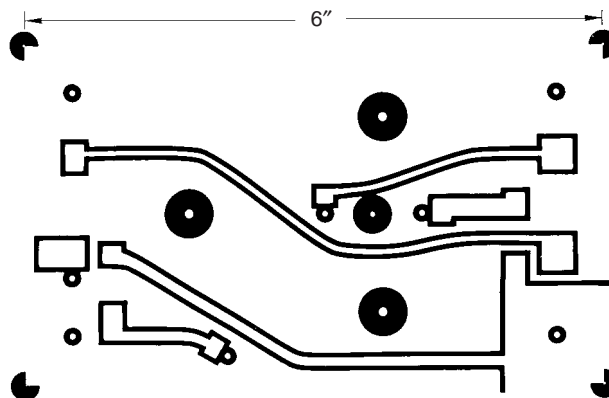

Figure 25. Bottom PC Board Pattern

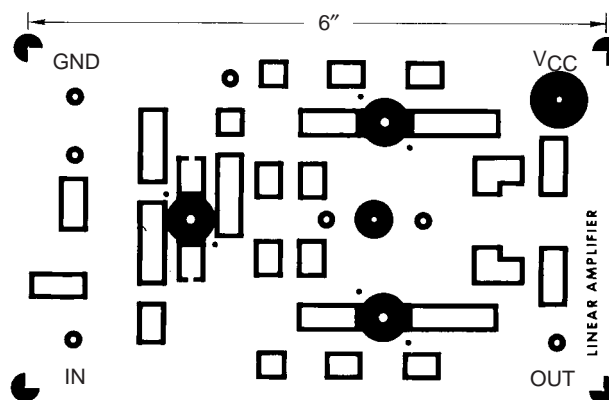

Figure 26. Top Side of PC Board

Table 3. Harmonic Suppression versus Frequency

| Harmonic  |        | 2nd    | 3rd    | 4th    | 5th    |
|-----------|--------|--------|--------|--------|--------|
| Frequency | 3 MHz  | -19 dB | -15 dB | -26 dB | -29 dB |
|           | 6 MHz  | -17 dB | -18 dB | -23 dB | -35 dB |
|           | 12 MHz | -30 dB | -20 dB | -28 dB | -34 dB |
|           | 30 MHz | -35 dB | -25 dB | -50 dB | -62 dB |

### CONSTRUCTION NOTES (28 V Version)

The 28 volt unit is less critical than the 12.5 V amplifier as far as the physical circuit lay-out is concerned. However, the same precautions should be taken in grounding the by-pass capacitors and the transformer high frequency-compensation capacitors. It is recommended that variable capacitors, such as the ARCO 460 line be used initially for the compensating capacitors. Then after establishing satisfactory operation of the unit, they can be changed to fixed value capacitors.

## IMPROVED PERFORMANCE

Since the original work on these amplifiers, device improvements have been made. Both IMD and load mismatch ruggedness characteristics can be enhanced by substituting the MRF463 or MRF464 for the 2N5942 in the 28-Volt amplifier. The MRF460 is recommended for upgrading the 12-Volt amplifier using the 2N6368. Neither of these new devices require circuit modifications for optimum operation.

## REFERENCES

1. Ruthroff: Some Broad Band Transformers, *IRE, Volume 47*, August, 1957.
2. Hilbers: Design of H. F. Wideband Power Transformers, *Philips Application Information #530*.
3. Pitzalis-Couse: Broadband Transformer Design for RF Transistor Amplifiers, *ECOM-2989*, July 1968.
4. Pappenfus; Bruene, Schoenike: Single Sideband Principles and Circuits, McGraw-Hill.
5. Granberg, H.; *Broadband Transformers and Power Combining Techniques for RF*, AN-749 Motorola Semiconductor Products Inc., June 1975.
6. Granberg, H.; *Get 300 Watts PEP Linear Across 2 to 30 MHz From This Push-Pull Amplifier*, EB-27 Motorola Semiconductor Products Inc., September 1974.
7. Granberg, H.; *A Complementary Symmetry Amplifier for 2 to 30 MHz SSB Driver Applications*, EB-32 Motorola Semiconductor Products Inc., February 1975.
8. Granberg, H.; *Measuring the Intermodulation Distortion of Linear Amplifiers*, EB-38 Motorola Semiconductor Products Inc., January 1975.

Motorola reserves the right to make changes without further notice to any products herein. Motorola makes no warranty, representation or guarantee regarding the suitability of its products for any particular purpose, nor does Motorola assume any liability arising out of the application or use of any product or circuit, and specifically disclaims any and all liability, including without limitation consequential or incidental damages. "Typical" parameters can and do vary in different applications. All operating parameters, including "Typicals" must be validated for each customer application by customer's technical experts. Motorola does not convey any license under its patent rights nor the rights of others. Motorola products are not designed, intended, or authorized for use as components in systems intended for surgical implant into the body, or other applications intended to support or sustain life, or for any other application in which the failure of the Motorola product could create a situation where personal injury or death may occur. Should Buyer purchase or use Motorola products for any such unintended or unauthorized application, Buyer shall indemnify and hold Motorola and its officers, employees, subsidiaries, affiliates, and distributors harmless against all claims, costs, damages, and expenses, and reasonable attorney fees arising out of, directly or indirectly, any claim of personal injury or death associated with such unintended or unauthorized use, even if such claim alleges that Motorola was negligent regarding the design or manufacture of the part. Motorola and  are registered trademarks of Motorola, Inc. Motorola, Inc. is an Equal Opportunity/Affirmative Action Employer.

**Literature Distribution Centers:**

USA: Motorola Literature Distribution; P.O. Box 20912; Phoenix, Arizona 85036.

EUROPE: Motorola Ltd.; European Literature Centre; 88 Tanners Drive, Blakelands, Milton Keynes, MK14 5BP, England.

JAPAN: Nippon Motorola Ltd.; 4-32-1, Nishi-Gotanda, Shinagawa-ku, Tokyo 141, Japan.

ASIA PACIFIC: Motorola Semiconductors H.K. Ltd.; Silicon Harbour Center, No. 2 Dai King Street, Tai Po Industrial Estate, Tai Po, N.T., Hong Kong.

