

SUPPRESSING ACOUSTIC NOISE IN PWM FAN SPEED CONTROL SYSTEMS

By Don Alfano, Kyle Gaede and Paul Paglia

INTRODUCTION

Fan speed control extends fan service life and decreases acoustic airflow noise and average fan current. The most efficient way to implement fan speed control is to use low frequency pulse width modulation (PWM). However, PWM fan speed control can sometimes introduce unwanted acoustic noise at a frequency equal to that of the PWM itself. This is especially noticeable when PWM control is used with higher operating current (>300 mA) fans, and at low operating speeds. This application note discusses the source of this acoustic noise and a method to suppress it.

BDC FAN BASICS

BDC fan motors operate in much the same way as mechanically commutated DC electric motors. The basic components of the BDC fan motor are the stator, rotor assembly, rotor position sensor and on-board commutation

control chip (Figure 1). The stator is a wound, stationary set of electromagnets, connected in a multi-phase configuration. It resides in the fan's frame for better heat dissipation and greater fan frame rigidity. The rotor assembly consists of a soft iron core with permanent magnetic poles that is assembled into a hollow plastic hub with attached fan blades. The rotor assembly is attached to an axle that rides on a pair of center bearings installed in the fan frame such that the rotor's permanent magnets rotate freely about the outside circumference of the stator. The rotor position sensor is typically a Hall effect device, directly actuated by the stator's magnetic poles. The commutation control chip uses the signal from the rotor position sensor to time the sequential switching of each stator phase, so that a rotating electromagnetic field is established around the stator. The rotor is set in motion by the magnetic coupling between this rotating electromagnetic field and its own magnetic pole.

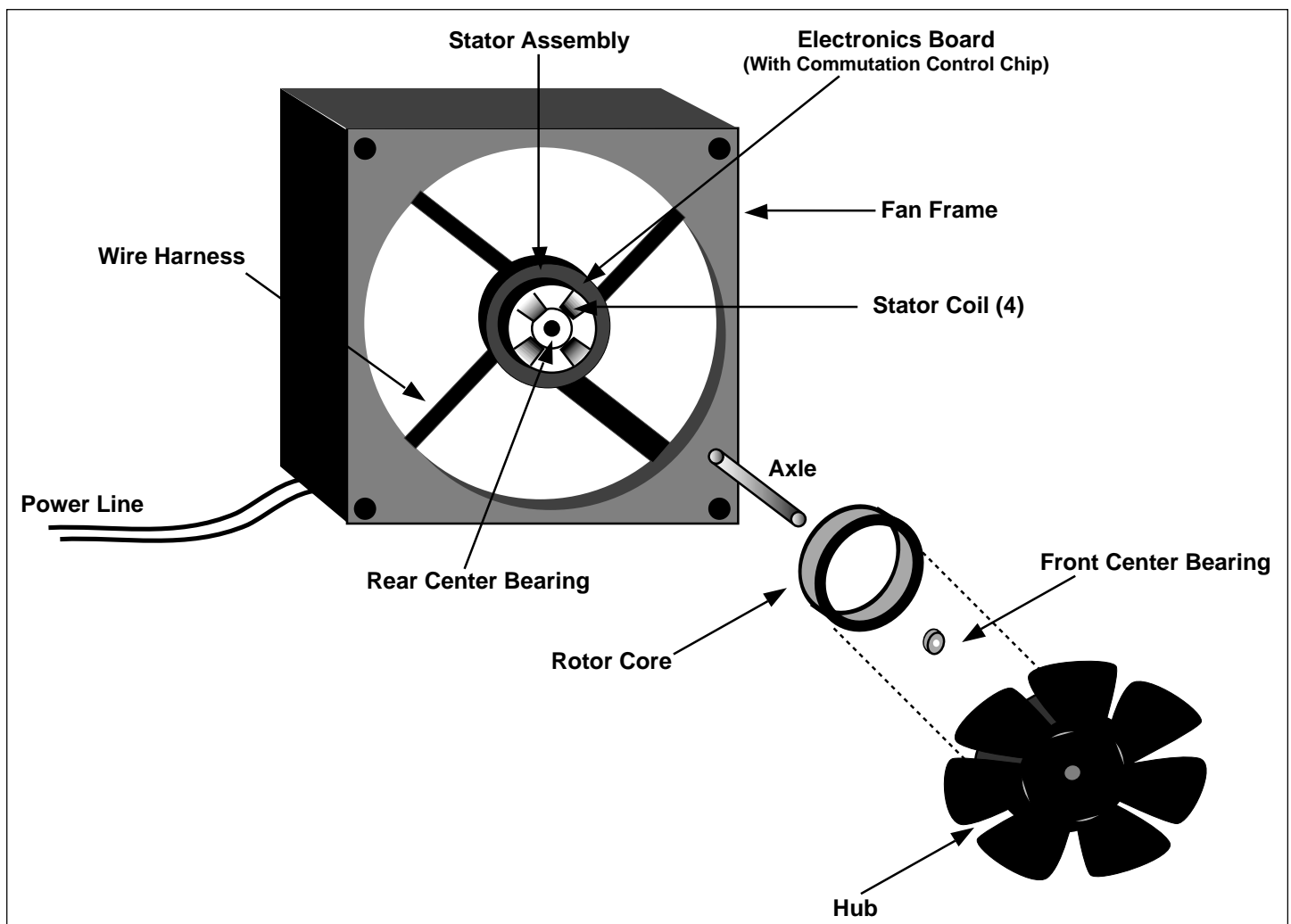

Figure 1. Typical BDC Fan

ACOUSTIC NOISE SOURCES

The most dominant source of acoustic fan noise is turbulent airflow, which is caused by fan operation at full speed. Employing fan speed control (where the fan is operated primarily at lower than full speed) minimizes this noise. The second most dominant acoustic noise is due to BDC fan's torque characteristic. As shown in Figure 2, stator excitation is a square wave that is switched ON 45° before peak torque position, and switched OFF 45° after peak torque position. This excitation causes a small amount of ripple in motor torque at the frequency of commutation. Each small torque "burst" causes a minute flexing of the entire fan structure, and results in a faint (but audible) "ticking" noise while the BDC fan is operating (Figure 2A).

Acoustic PWM noise is generated in exactly the same way. When the PWM pulse turns on, a step change in torque occurs within the fan, the profile of which matches the rise time of the PWM pulse (Figure 2B). This impulse torque is articulated by the fan structure as audible noise. This is true mostly in larger fans (i.e., fans with operating currents in excess of 300 mA), since they generate a greater amount of torque and have larger size and mass. This effect is more

pronounced at low operating speeds (i.e., low PWM duty cycle): the lower the PWM duty cycle, the greater the percentage of time the fan is OFF (quiet), and the more noticeable the acoustic noise caused by the PWM becomes.

SUPPRESSING PWM NOISE

As previously explained, PWM acoustic noise is caused by the impulse torque generated by the fan motor during each active PWM cycle. Reducing this acoustic noise involves slowing the slew rate of the PWM switching, thereby "smoothing" the PWM impulse torque profile. The circuit in Figure 3 depicts any PWM fan controller (such as TelCom's TC646) driving a low-side switching transistor. The added small base capacitor reduces the slew rate of the driving waveform (and, therefore, the slew rate of the output switching). The value of the capacitor must be determined experimentally, since it is a function of the fan mounting, supply voltage, operating current, and torque characteristics. In general, the RC product of the base drive resistor and capacitor should be 4.7 μ F to 47.0 μ F for a base resistor in the range of 1 K Ω to 10 K Ω .

DRIVING INDUCTIVE LOADS

Inductive kick is another problem that can arise in fans with larger drive currents. As stated earlier, the stator motor is made up of electromagnetic coils. Because all inductors have the property $V=L(di/dt)$, the inductor current cannot go to zero instantaneously. The motor coil, which happens to be energized at the time the switch opens, reverses polarity in an attempt to maintain constant current. The voltage on the ground terminal of the fan can increase to 70V or more. This high voltage can result in damage to the drive transistor. The slow down capacitor prevents this because the transistor is not turned off instantaneously. The slower transition time gives the inductor current time to ramp down before turnoff (see scope plots in figure 4).

In Figure 4a, trace 1 shows the fan's ground wire voltage, while trace 2 shows the base of the switching transistor. Figure 4b shows the same traces on a different time scale. Figure 4c shows the same fan with the addition of the slow down cap. The large voltage spike is gone, and the acoustic noise is reduced dramatically. These plots were taken using the TC642EV and a 400mA fan.

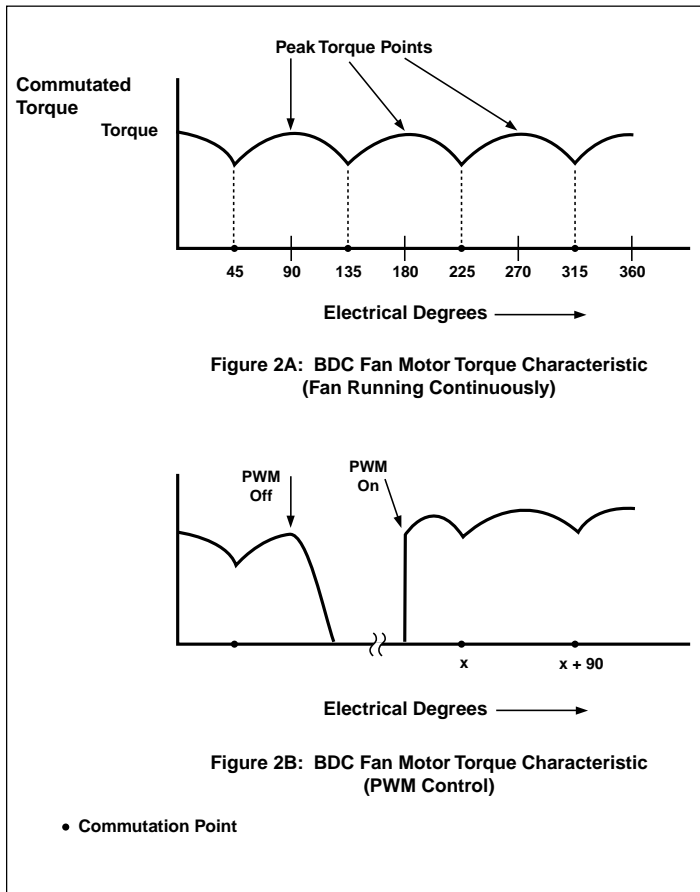

Figure 2. BDC Fan Torque Characteristics

SUPPRESSING ACOUSTIC NOISE IN PWM FAN SPEED CONTROL SYSTEMS

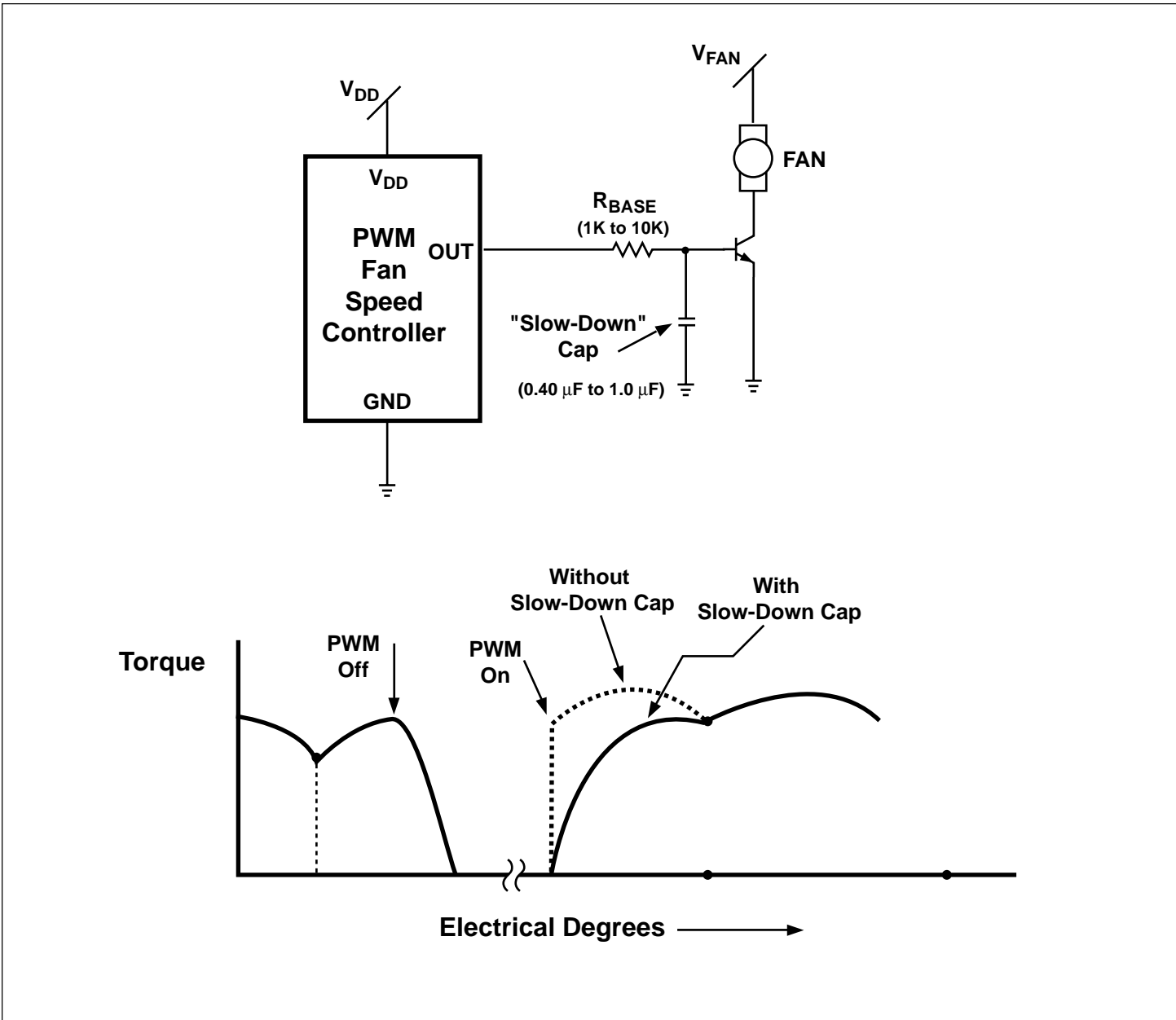

Figure 3. PWM Acoustic Noise Suppression Technique

SUPPRESSING ACOUSTIC NOISE IN PWM FAN SPEED CONTROL SYSTEMS

AN-58

SUMMARY

PWM noise, as well as inductive kick, can be reduced or eliminated by slowing the slew rate of the PWM drive signal to the fan. Even a small reduction in slew rate results in a significant reduction of the PWM noise. The noise suppression circuit implementation is simple, requiring only the addition of

a small capacitor to the base of the PWM switching transistor. For very large fans (more than 500 mA operating current), DC speed control may be required (please see TelCom Application Note #57 for implementing such a circuit).

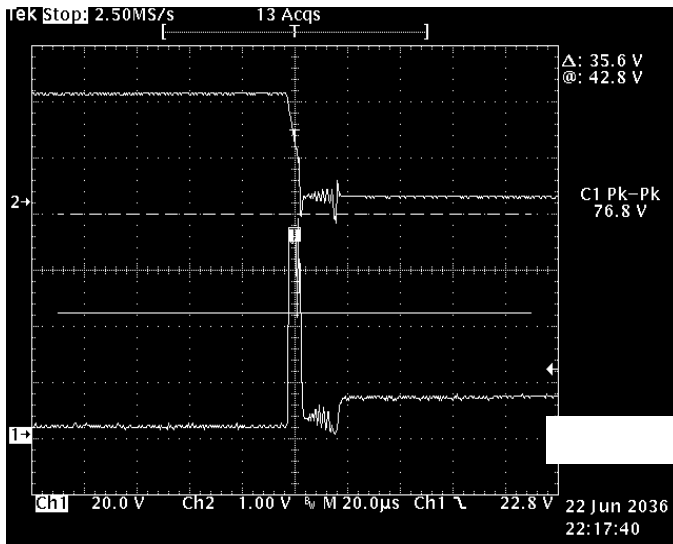

Figure 4a. Inductive kick voltage spike. No slow down cap. 20µsec time scale.

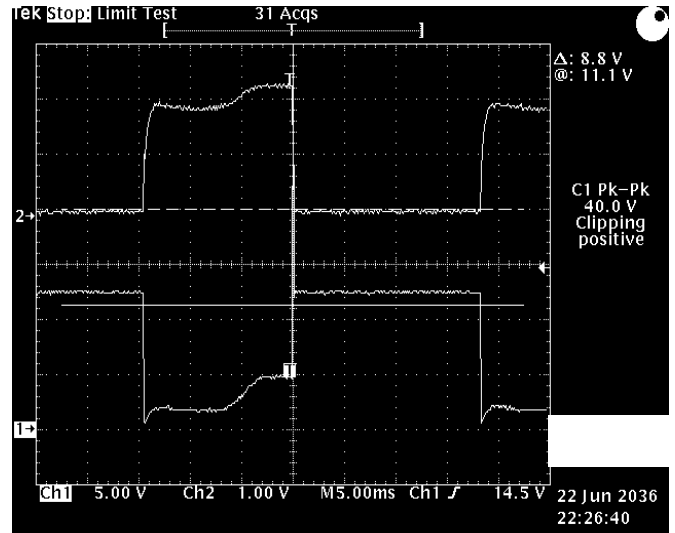

Figure 4b. Inductive kick voltage spike. No slow down cap. 5msec time scale.

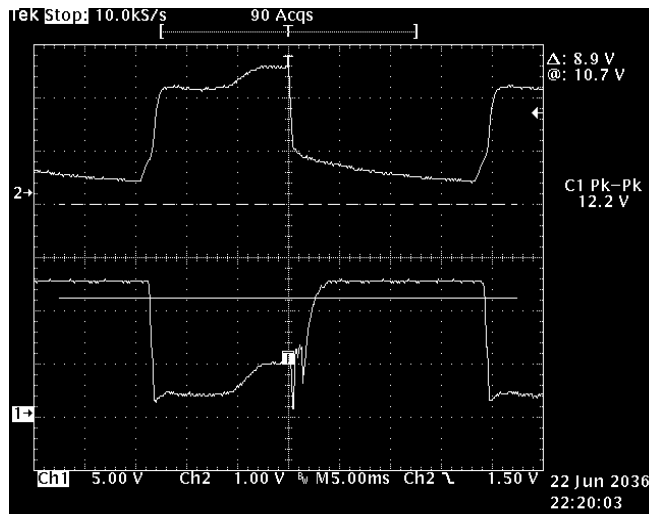

Figure 4c. Using 10µF slow down cap with 1.1KΩ base resistor. Notice the lack of voltage spike and more rounded edges of Trace 1.

SUPPRESSING ACOUSTIC NOISE IN PWM FAN SPEED CONTROL SYSTEMS

AN-58

Sales Offices

TelCom Semiconductor, Inc.
1300 Terra Bella Avenue
P.O. Box 7267
Mountain View, CA 94039-7267
TEL: 650-968-9241
FAX: 650-967-1590
E-Mail: liter@telcom-semi.com

TelCom Semiconductor, GmbH
Lochhamer Strasse 13
D-82152 Martinsried
Germany
TEL: (011) 49 89 895 6500
FAX: (011) 49 89 895 6502 2

TelCom Semiconductor H.K. Ltd.
10 Sam Chuk Street, Ground Floor
San Po Kong, Kowloon
Hong Kong
TEL: (011) 852-2350-7380
FAX: (011) 852-2354-9957