



Metric Bevel Gear Sets

In Steel EN 8 (080M40, 080M46) or equivalent

2.0 : 1 Ratio

Cut to the Gleason system

Bore tolerance H8

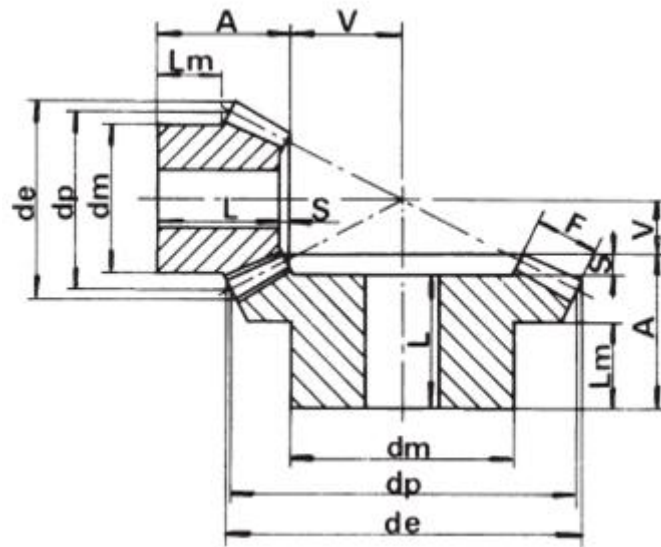

All gears are supplied chemi black finish
 All dimensions in mm
 Shaft axis to intersect within +/- 0.025mm
 Angular accuracy between shafts +/- 5 mins
 Mounting distance tolerances +/- 0.05mm

RS Article no.	Code	Pitch Module	No. Teeth	dp	A+V	dm	Bore	F	A	de	S	Lm
5215976	SRB15/15	1.5	15	22.5	32	16	6	8	17.23	26.11	1.73	7.88
5215982	SRB15/30		30	45	25	25	8	8	17.85	45.88	2.85	9
5215998	SRB20/15	2	15	30	40	22	8	11	20.59	34.81	2.59	8
5216008	SRB20/30		30	60	31	30	10	11	21.6	61.17	3.6	10
5216014	SRB25/15	2.5	15	37.5	55	30	12	15	31.81	43.51	2.81	15.63
5216020	SRB25/30		30	75	40	40	15	15	28.75	76.46	4.75	15