

FEATURES

- 4.72 mm × 3.76 mm × 1.0 mm surface mount package
- 131 dB SPL acoustic overload point
- Sensitivity of -46 dBV
- ±2 dB sensitivity tolerance
- Omnidirectional response
- High SNR of 62 dBA
- Extended frequency response from 28 Hz to 20 kHz
- Low current consumption: <250 μA
- Single-ended analog output
- High PSR of -80 dBV
- Compatible with Sn/Pb and Pb-free solder processes
- RoHS/WEEE compliant

APPLICATIONS

- Fire and safety radios
- Safety masks
- Smartphones and feature phones
- Tablet computers
- Teleconferencing systems
- Digital still and video cameras
- Studio microphones
- Bluetooth headsets
- Security and surveillance

GENERAL DESCRIPTION

The [ADMP411](#)¹ is a high performance, high SPL, low noise, low power, analog output bottom ported, omnidirectional MEMS microphone. The [ADMP411](#) consists of a MEMS microphone element and an impedance converter amplifier. The [ADMP411](#) sensitivity specification makes it an excellent choice for both near field and far field applications. The [ADMP411](#) is pin compatible with the [ADMP401](#) microphone, providing an easy upgrade path.

FUNCTIONAL BLOCK DIAGRAM

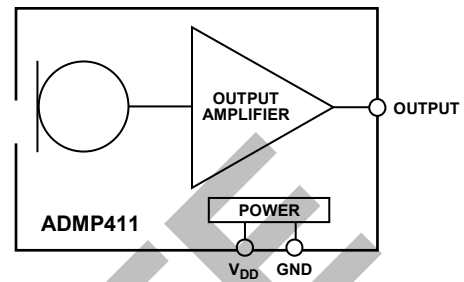

Figure 1.

10913-001

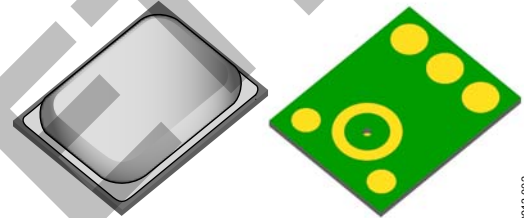

Figure 2. Isometric Views of Microphone Package

10913-002

The [ADMP411](#) has a linear response up to 131 dB SPL. It offers high SNR and extended wideband frequency response resulting in natural sound with high intelligibility. Low current consumption enables long battery life for portable applications.

The [ADMP411](#) is available in a miniature 4.72 mm × 3.76 mm × 1.0 mm surface-mount package. It is reflow solder compatible with no sensitivity degradation.

¹ Protected by U.S. Patents 7,449,356; 7,825,484; 7,885,423; 7,961,897. Other patents are pending.

IMPORTANT LINKS for the [ADMP411](#)*

Last content update 09/20/2013 08:58 pm

DOCUMENTATION

AN-1181: Using a MEMS Microphone in a 2-Wire Microphone Circuit

AN-1165: Op Amps for MEMS Microphone Preamp Circuits

AN-1140: Microphone Array Beamforming

AN-1124: Recommendations for Sealing Analog Devices, Inc., Bottom-Port MEMS Microphones from Dust and Liquid Ingress

AN-1112: Microphone Specifications Explained

AN-1068: Reflow Soldering of the MEMS Microphone

AN-1003: Recommendations for Mounting and Connecting Analog Devices, Inc., Bottom-Ported MEMS Microphones

CN0284: High Performance, Low-Noise Studio Microphone with MEMS Microphones, Analog Beamforming, and Power Management

UG-445: EVAL-ADMP411Z-FLEX Bottom-Ported Analog Output MEMS Microphone Evaluation Board

DESIGN TOOLS, MODELS, DRIVERS & SOFTWARE

Microphone Beamforming Simulation Tool (32-bit)

- Documentation for the microphone beamforming simulator

Microphone Beamforming Simulation Tool (64-bit)

- Documentation for the microphone beamforming simulator

EVALUATION KITS & SYMBOLS & FOOTPRINTS

View the Evaluation Boards and Kits page for documentation and purchasing

Symbols and Footprints

SUGGESTED COMPANION PRODUCTS

CN-0284: High Performance, Low-Noise Studio Microphone with MEMS Microphones, Analog Beamforming, and Power Management

PARAMETRIC SELECTION TABLES

[Find Similar Products By Operating Parameters](#)

DESIGN COLLABORATION COMMUNITY



[Collaborate Online](#) with the ADI support team and other designers about select ADI products.

Follow us on Twitter: www.twitter.com/ADI_News

Like us on Facebook: www.facebook.com/AnalogDevicesInc

DESIGN SUPPORT

Submit your support request here:

[Linear and Data Converters](#)

[Embedded Processing and DSP](#)

Telephone our Customer Interaction Centers toll free:

Americas: 1-800-262-5643

Europe: 00800-266-822-82

China: 4006-100-006

India: 1800-419-0108

Russia: 8-800-555-45-90

[Quality and Reliability](#)

[Lead\(Pb\)-Free Data](#)

SAMPLE & BUY

ADMP411

- View Price & Packaging
- Request Evaluation Board
- Request Samples
- Check Inventory & Purchase

[Find Local Distributors](#)

* This page was dynamically generated by Analog Devices, Inc. and inserted into this data sheet.
Note: Dynamic changes to the content on this page (labeled 'Important Links') does not constitute a change to the revision number of the product data sheet.
This content may be frequently modified.

TABLE OF CONTENTS

Features	1	Codec Connections.....	7
Applications.....	1	Dynamic Range Considerations.....	7
Functional Block Diagram	1	Supporting Documents	7
General Description	1	Handling Instructions.....	8
Revision History	2	Pick and Place Equipment.....	8
Specifications.....	3	Reflow Solder	8
Absolute Maximum Ratings.....	4	Board Wash	8
ESD Caution.....	4	PCB Land Pattern Layout.....	9
Pin Configuration and Function Descriptions.....	5	Outline Dimensions	10
Typical Performance Characteristics	6	Ordering Guide	10
Applications Information	7		

REVISION HISTORY

4/13—Revision 0: Initial Version

OBSOLETE

SPECIFICATIONS

$T_A = 25^\circ\text{C}$, $V_{DD} = 1.8\text{ V}$, unless otherwise noted. All minimum and maximum specifications are guaranteed. Typical specifications are not guaranteed.

Table 1.

Parameter	Test Conditions/Comments	Min	Typ	Max	Unit
PERFORMANCE					
Directionality			Omni		
Sensitivity	1 kHz, 94 dB SPL	-48	-46	-44	dBV
Signal-to-Noise Ratio (SNR)	20 Hz to 20 kHz, A-weighted		62		dB
Equivalent Input Noise (EIN)	20 Hz to 20 kHz, A-weighted		32		dB SPL
Dynamic Range	Derived from EIN and maximum acoustic input		99		dB
Frequency Response ¹	Low frequency -3 dB point		28		Hz
	High frequency -3 dB point		>20		kHz
Total Harmonic Distortion (THD)	105 dB SPL		0.2	1	%
Power Supply Rejection (PSR)	217 Hz, 100 mV p-p square wave superimposed on $V_{DD} = 1.8\text{ V}$		-80		dBV
Power Supply Rejection Ratio (PSRR)	1 kHz, 100 mV p-p sine wave superimposed on $V_{DD} = 1.8\text{ V}$		-46		dB
Acoustic Overload Point	10% THD		131		dB SPL
POWER SUPPLY					
Supply Voltage (V_{DD})		1.5		3.63	V
Supply Current (I_S)	$V_{DD} = 1.8\text{ V}$		180	220	μA
	$V_{DD} = 3.3\text{ V}$		210	250	μA
OUTPUT CHARACTERISTICS					
Output Impedance (Z_{OUT})			200		Ω
Output DC Offset			0.8		V
Maximum Output Voltage	131 dB SPL input		0.355		V rms
Noise Floor	20 Hz to 20 kHz, A-weighted, rms		-108		dBV

¹ See Figure 5 and Figure 6.

ABSOLUTE MAXIMUM RATINGS

Table 2.

Parameter	Rating
Supply Voltage	-0.3 V to +3.63 V
Sound Pressure Level (SPL)	160 dB
Mechanical Shock	10,000 g
Vibration	Per MIL-STD-883 Method 2007, Test Condition B
Storage Temperature Range	-40°C to +150°C
Operating Temperature Range	-40°C to +85°C

Stresses above those listed under Absolute Maximum Ratings may cause permanent damage to the device. This is a stress rating only; functional operation of the device at these or any other conditions above those indicated in the operational section of this specification is not implied. Exposure to absolute maximum rating conditions for extended periods may affect device reliability.

ESD CAUTION



ESD (electrostatic discharge) sensitive device. Charged devices and circuit boards can discharge without detection. Although this product features patented or proprietary protection circuitry, damage may occur on devices subjected to high energy ESD. Therefore, proper ESD precautions should be taken to avoid performance degradation or loss of functionality.

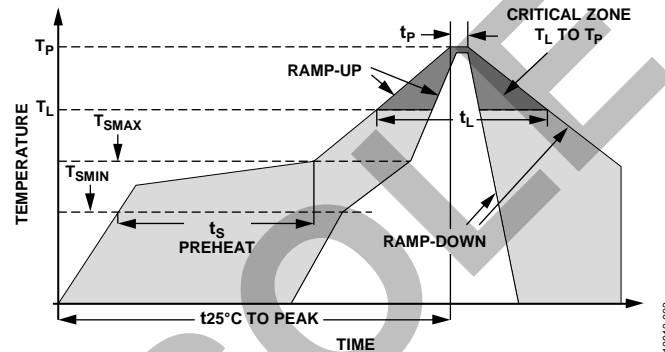
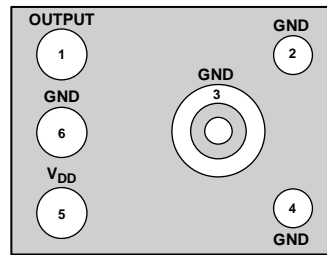

Figure 3. Recommended Soldering Profile Limits

Table 3. Recommended Soldering Profile Limits

Profile Feature	Sn63/Pb37	Pb-Free
Average Ramp Rate (T_L to T_P)	1.25°C/sec maximum	1.25°C/sec maximum
Preheat		
Minimum Temperature (T_{SMIN})	100°C	150°C
Maximum Temperature (T_{SMAX})	150°C	200°C
Time (T_{SMIN} to T_{SMAX}), t_s	60 sec to 75 sec	60 sec to 75 sec
Ramp-Up Rate (T_{SMAX} to T_L)	1.25°C/sec	1.25°C/sec
Time Maintained Above Liquidous (t_L)	45 sec to 75 sec	~50 sec
Liquidous Temperature (T_L)	183°C	217°C
Peak Temperature (T_P)	215°C + 3°C/-3°C	260°C + 0°C/-5°C
Time Within 5°C of Actual Peak Temperature (t_p)	20 sec to 30 sec	20 sec to 30 sec
Ramp-Down Rate	3°C/sec maximum	3°C/sec maximum
Time 25°C to Peak Temperature	5 minute maximum	5 minute maximum

PIN CONFIGURATION AND FUNCTION DESCRIPTIONS



BOTTOM VIEW
(Not to Scale)

Figure 4. Pin Configuration

10813-004

Table 4. Pin Function Descriptions

Pin No.	Mnemonic	Description
1	OUTPUT	Analog Output Signal
2	GND	Ground
3	GND	Ground
4	GND	Ground
5	V _{DD}	Power Supply
6	GND	Ground

TYPICAL PERFORMANCE CHARACTERISTICS

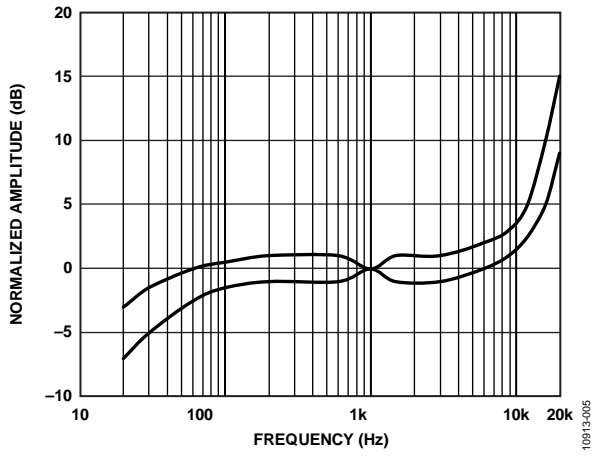

Figure 5. Frequency Response Mask

10913-005

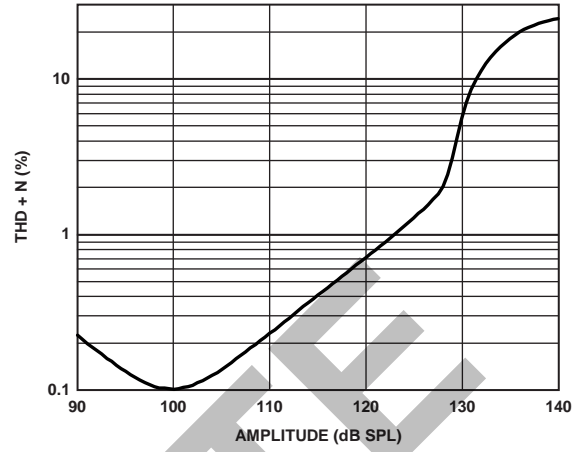

Figure 8. THD + N vs. Input Level

10913-008

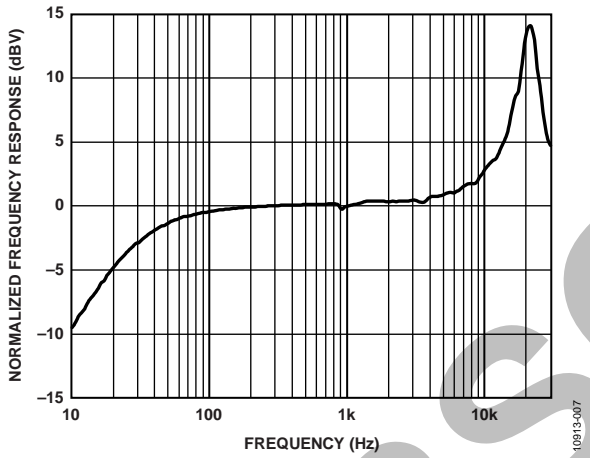

Figure 6. Typical Frequency Response (Measured)

10913-007

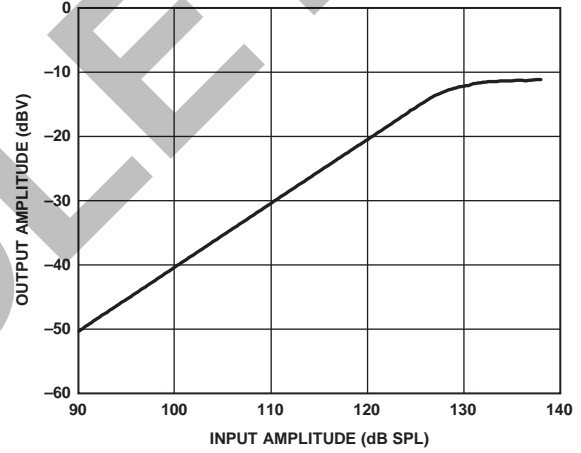

Figure 9. Linearity

10913-009

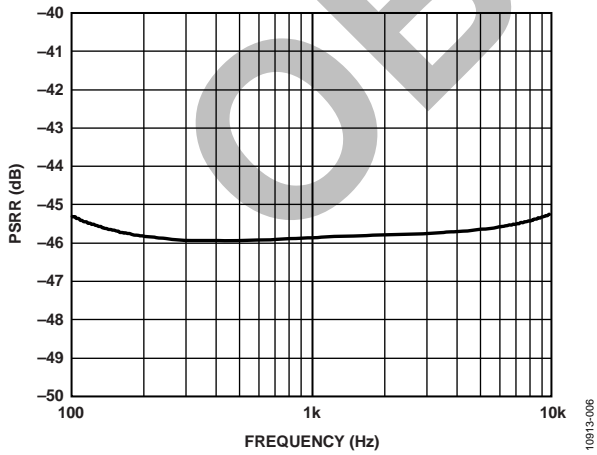

Figure 7. Typical Power Supply Rejection Ratio vs. Frequency

10913-006

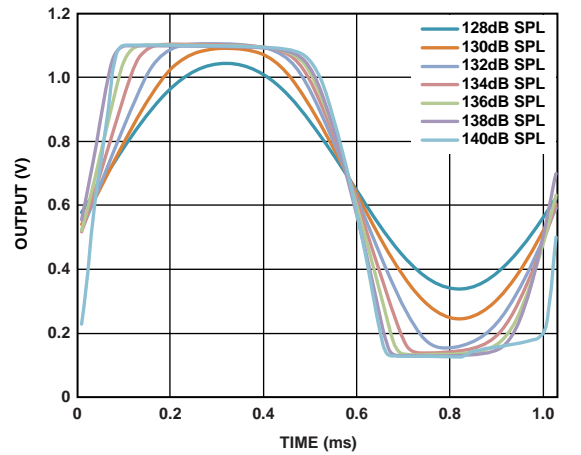

Figure 10. Clipping Characteristics

10913-014

APPLICATIONS INFORMATION

CODEC CONNECTIONS

The **ADMP411** output can be connected to a dedicated codec microphone input (see Figure 11) or to a high input impedance gain stage (see Figure 12). A 0.1 μF ceramic capacitor placed close to the **ADMP411** supply pin is used for testing and is recommended to adequately decouple the microphone from noise on the power supply. A dc blocking capacitor is required at the output of the microphone. This capacitor creates a high-pass filter with a corner frequency at

$$f_c = 1/(2\pi \times C \times R)$$

where R is the input impedance of the codec.

A minimum value of 4.7 μF is recommended in Figure 11 because the **ADAU1761/ADAU1361** input impedance can be as low as 2 k Ω at its highest PGA gain setting, which results in a high-pass filter corner frequency at 17 Hz.

Figure 12 shows the **ADMP411** connected to an **ADA4075-2** op amp configured as a noninverting preamplifier. The **AN-1165 Application Note** describes using op amps for microphone preamp circuits and includes a list of recommended Analog Devices, Inc., op amps.

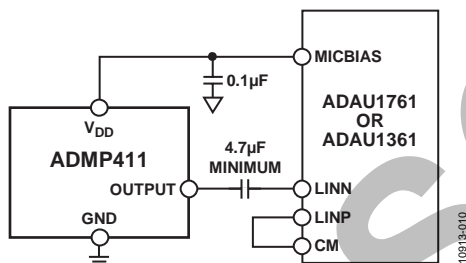

Figure 11. **ADMP411** Connected to the Analog Devices **ADAU1761** or **ADAU1361** Codec

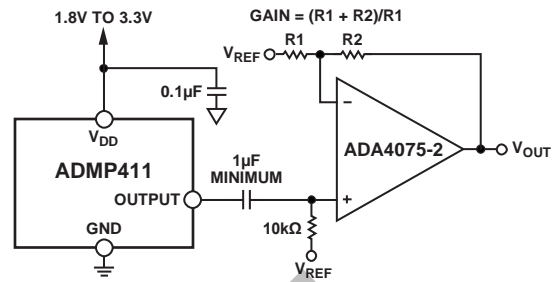

Figure 12. **ADMP411** Connected to the **ADA4075-2** Op Amp

DYNAMIC RANGE CONSIDERATIONS

To fully utilize the 99 dB dynamic range of the **ADMP411** in a design, the preamp, ADC, or codec circuit following it must be chosen carefully. For example, the **ADAU1761** has a 98 dB dynamic range with $V_{DD} = 3.3$ V. To match the dynamic ranges between the microphone and the ADC input of the codec, some gain must be added to the **ADMP411** output. For example, at the 131 dB SPL maximum acoustic input, the **ADMP411** outputs a -13 dBV rms signal. The full-scale input voltage of the **ADAU1761** ADC is 0 dBV; therefore, 13 dB of gain must be added to the signal to match the dynamic range of the microphone with the dynamic range of the codec.

SUPPORTING DOCUMENTS

Evaluation Board User Guide

[UG-445, EVAL-ADMP411Z-FLEX: Bottom-Ported Analog Output MEMS Microphone Evaluation Board](#)

Application Notes

[AN-1003, Recommendations for Mounting and Connecting Analog Devices, Inc., Bottom-Ported MEMS Microphones](#)

[AN-1068, Reflow Soldering of the MEMS Microphone](#)

[AN-1112, Microphone Specifications Explained](#)

[AN-1124, Recommendations for Sealing Analog Devices, Inc., Bottom-Port MEMS Microphones from Dust and Liquid Ingress](#)

[AN-1140, Microphone Array Beamforming](#)

[AN-1165, Op Amps for MEMS Microphone Preamp Circuits](#)

[AN-1181, Using a MEMS Microphone in a 2-Wire Microphone Circuit](#)

HANDLING INSTRUCTIONS

PICK AND PLACE EQUIPMENT

The MEMS microphone can be handled using standard pick and place and chip shooting equipment. Take care to avoid damage to the MEMS microphone structure as follows:

- Use a standard pickup tool to handle the microphone. Because the microphone hole is on the bottom of the package, the pickup tool can make contact with any part of the lid surface.
- Do not pick up the microphone with a vacuum tool that makes contact with the bottom side of the microphone.
- Do not pull air out or blow air into the microphone port.
- Do not use excessive force to place the microphone on the PCB.

REFLOW SOLDER

For best results, the soldering profile should be in accordance with the recommendations of the manufacturer of the solder paste used to attach the MEMS microphone to the PCB. It is recommended that the solder reflow profile not exceed the limit conditions specified in Figure 3 and Table 3. For more detailed recommendations, see the [AN-1068 Application Note](#), *Reflow Soldering of the MEMS Microphone*.

BOARD WASH

When washing the PCB, ensure that water does not make contact with the microphone port. Blowoff procedures and ultrasonic cleaning must not be used.

OBSOLETE

PCB LAND PATTERN LAYOUT

The recommended PCB land pattern for the ADMP411 is laid out to a 1:1 ratio to the solder pads on the microphone package, as shown in Figure 13. Take care to avoid applying solder paste to the sound hole in the PCB. A suggested solder paste stencil

pattern layout is shown in Figure 14. The diameter of the sound hole in the PCB should be larger than the diameter of the sound port of the microphone. A minimum diameter of 0.5 mm is recommended.

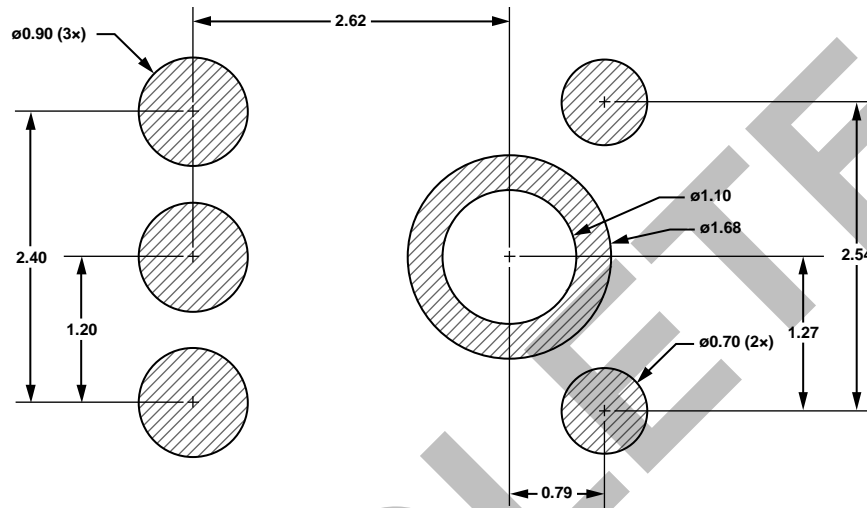

Figure 13. PCB Land Pattern Layout (Dimensions Shown in Millimeters)

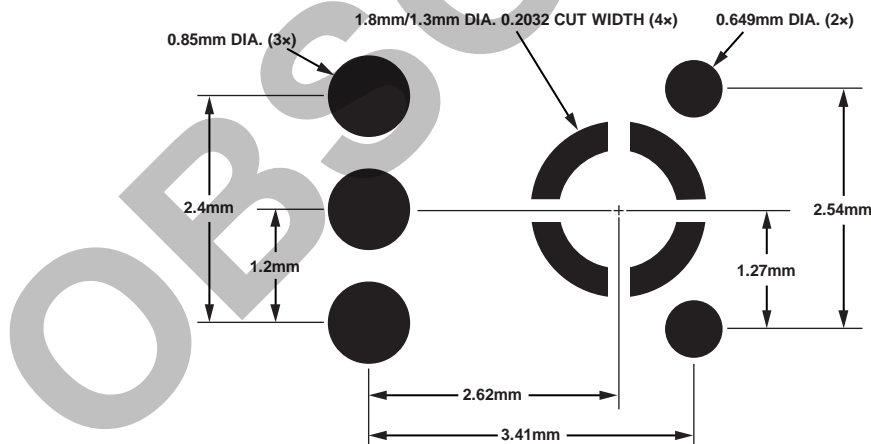

Figure 14. Suggested Solder Paste Stencil Pattern Layout

OUTLINE DIMENSIONS

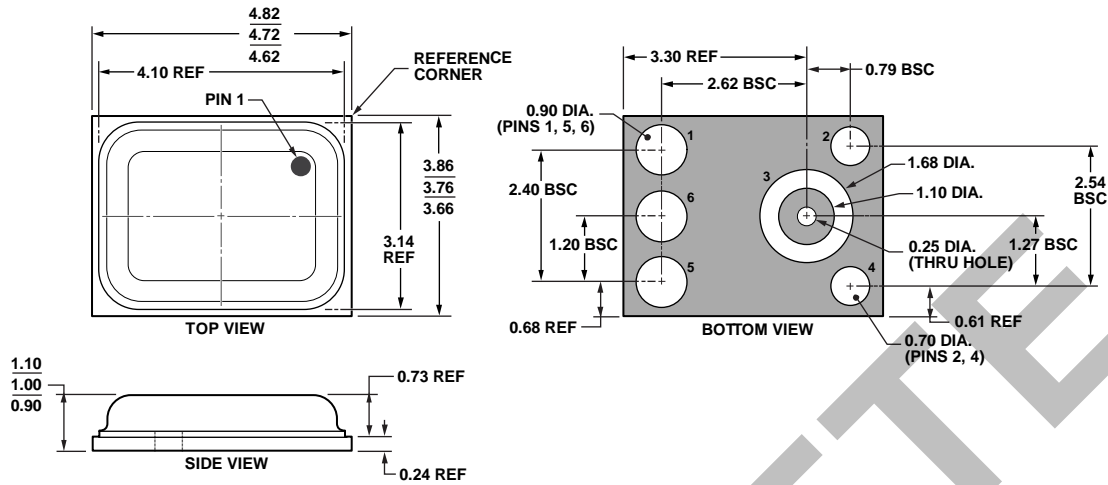

Figure 15. 6-Terminal Chip Array Small Outline No Lead Cavity [LGA_CAV]
 4.72 mm x 3.76 mm Body
 (CE-6-1)
 Dimensions shown in millimeters

12-12-2011-C

ORDERING GUIDE

Model ¹	Temperature Range	Package Description	Package Option	Ordering Quantity
ADMP411ACEZ-RL	-40°C to +85°C	6-Terminal LGA_CAV, 13" Tape and Reel	CE-6-1	4,500
ADMP411ACEZ-RL7	-40°C to +85°C	6-Terminal LGA_CAV, 7" Tape and Reel	CE-6-1	1,000
EVAL-ADMP411Z-FLEX		Flex Evaluation Board		

¹ Z = RoHS Compliant Part.

NOTES

OBSOLETE

NOTES

OBSOLETE