

Cable crimping type female contact for cable
(Miniature HKP series)
HKP-F () () 3B

Crimping for cable

Contacts

Miniature HKP series

RoHS



● Configuration of product Part No.

HKP-F () () 3B

① ②

- ① Series name
- ② Type of contact
F: Female

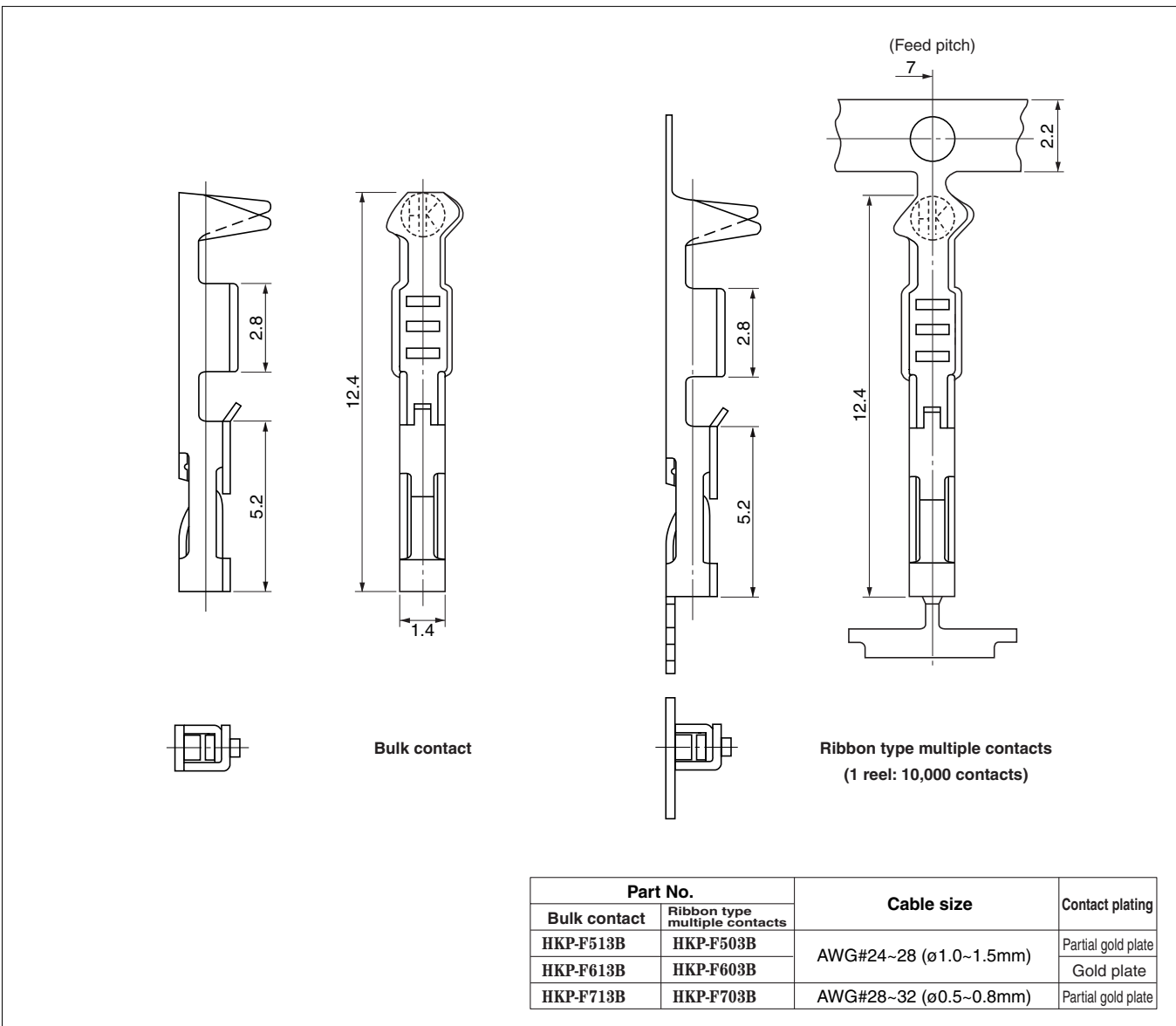

Mating connectors: HKP or FFC series connectors for PCB

Crimping machine: Press body: HTK-211

Applicator: KP-214 for HKP-F503B or HKP-F603B, KP-214SA for HKP-F703B

Hand crimping tool: KP-325 for F513B or HKP-F613B, KP-325D or HKP-F713B (Refer to page Tool-7)

Female insulator for crimping(Miniature HKP series)
 HKP-()FSA01

For cable

Crimping

RoHS

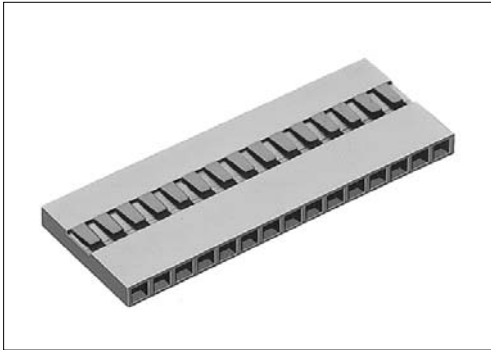

● Configuration of product Part No.

HKP- () F S A01

① ② ③ ④ ⑤

- ① Series name
- ② No. of contacts: 2-50
- ③ Type of insulator
F: Female
- ④ Alignment of contacts to be inserted
S: Single-row type
- ⑤ Type of HKP series
A: Miniature

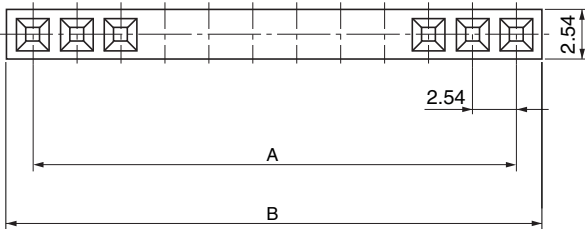
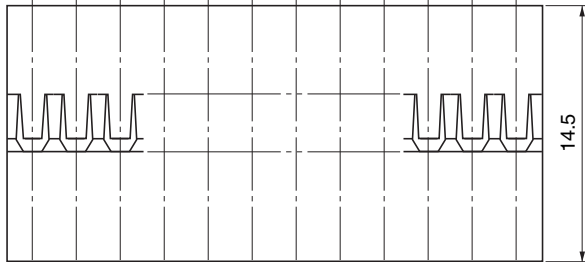

● Dimensions

Part No.	A	B
HKP-2FSA01	2.54	5.08
HKP-3FSA01	5.08	7.62
HKP-4FSA01	7.62	10.16
HKP-5FSA01	10.16	12.70
HKP-6FSA01	12.70	15.24
HKP-7FSA01	15.24	17.78
HKP-8FSA01	17.78	20.32
HKP-9FSA01	20.32	22.86
HKP-10FSA01	22.86	25.40
HKP-11FSA01	25.40	27.94
HKP-12FSA01	27.94	30.48
HKP-13FSA01	30.48	33.02
HKP-14FSA01	33.02	35.56
HKP-15FSA01	35.56	38.10
HKP-16FSA01	38.10	40.64
HKP-17FSA01	40.64	43.18
HKP-18FSA01	43.18	45.72
HKP-19FSA01	45.72	48.26
HKP-20FSA01	48.26	50.80
HKP-21FSA01	50.80	53.34
HKP-22FSA01	53.34	55.88
HKP-23FSA01	55.88	58.42
HKP-24FSA01	58.42	60.96
HKP-25FSA01	60.96	63.50
HKP-26FSA01	63.50	66.04

Part No.	A	B
HKP-27FSA01	66.04	68.58
HKP-28FSA01	68.58	71.12
HKP-29FSA01	71.12	73.66
HKP-30FSA01	73.66	76.20
HKP-31FSA01	76.20	78.74
HKP-32FSA01	78.74	81.28
HKP-33FSA01	81.28	83.82
HKP-34FSA01	83.82	86.36
HKP-35FSA01	86.36	88.90
HKP-36FSA01	88.90	91.44
HKP-37FSA01	91.44	93.98
HKP-38FSA01	93.98	96.52
HKP-39FSA01	96.52	99.06
HKP-40FSA01	99.06	101.60
HKP-41FSA01	101.60	104.14
HKP-42FSA01	104.14	106.68
HKP-43FSA01	106.68	109.22
HKP-44FSA01	109.22	111.76
HKP-45FSA01	111.76	114.30
HKP-46FSA01	114.30	116.84
HKP-47FSA01	116.84	119.38
HKP-48FSA01	119.38	121.92
HKP-49FSA01	121.92	124.46
HKP-50FSA01	124.46	127.00

Mating connectors: HKP or FFC series single-row type male connector

For use with contacts: Miniature HKP series contacts (HKP-F6@3B, HKP-F5@3B, HKP-F7@3B)