

Europe: Saxon Way, Bar Hill, Cambridge, CB3 8SL Tel: +44 (0)1954 782266 Fax: +44 (0)1954 782993

USA: 44370 Christy St., Fremont, CA 94538, USA Tel: (800) 775-OPTO Tel: (510) 979-6500 Fax: (510) 687-1344

USA: 35 Congress Street, Salem, MA 01970, USA Tel: (978) 745-3200 Fax: (978) 745-0894

Asia: 47 Ayer Rajah Crescent, 06-12, Singapore 139947 Tel: +65-775-2022 Fax: +65-775-1008

Japan: 18F, Parale Mitsui Building 8, Higashida-cho, Kawasaki-ku, Kawasaki-shi, Kanagawa-ken, 210-0005 Japan Tel: 81 44 200 9150 Fax: 81 44 200 9160

[www.perkinelmer.com/opto](http://www.perkinelmer.com/opto)

# High Performance Flash and Arc Lamps



Lighting

Imaging

Teleco

m



# Introduction

This publication is divided into two sections:

Part 1 – Technical Information

Part 2 – Product Range

Part 1 is intended to give the necessary technical information to manufacturers, designers and researchers to enable them to select the correct flashlamp for their application and also to give an insight into the design procedures necessary for correct flashlamp operation.

Part 2 is a guide to the wide, varied and complex range of lamps manufactured by PerkinElmer Optoelectronics. It illustrates most of the standard lamp outlines currently in world-wide use for laser pumping and similar applications, for example air cooled lamps, fluid cooled lamps, high pressure krypton arc lamps, etc.



It would be difficult, if not impossible, to present all the possible design variations that can be produced.

This section therefore is a guide and overview of

PerkinElmer's flash and arc lamp manufacturing programme.



## Past, Present and Future

Solid state laser systems have historically used pulsed and CW (DC) xenon or krypton filled arc lamps as excitation for pump sources. When in 1960, at Hughes Research Labs, the first practical pulsed laser system was demonstrated by

T. H. Maiman the technology and understanding involved in the manufacture and operation of flashlamps was of a very basic nature. Up to that time (1960) the major use of flashlamps was photography and related applications. In fact the Maiman ruby laser was pumped by a small, hard glass helical lamp, made by General Electric, intended for studio photography.

Throughout the 1960's lamp and laser development progressed hand in hand until by the later 1960's lamp technology was fairly mature. During this period the quartz/tungsten rod seal flashlamp had been developed, perfected and extensively adopted for high average power laser pumping. Also, during this time, specialist laser lamp manufacturing companies had been set up adding to the development and advancement of high technology laser lamps.

Lamp production has now progressed to the point where many advanced high performance designs are routinely available off the shelf or can be built in small quantities at short notice. Although production runs can be for several thousand lamps, they are still universally assembled using basically hand crafting techniques. It is because of this hand crafting that small production runs of specialised devices can be undertaken economically.

Much work has been undertaken in recent years to further improve lamp technology in new, demanding applications. A great deal of lamp development work is concentrated at the cathode, where new, rigorous service conditions are encountered when lamps are operated at high average powers and pulse durations in the millisecond regime. PerkinElmer utilises its company-wide diagnostic techniques to aid this research. Techniques such as finite element analysis and x-ray analysis are tools that play a significant role in lamp development.

PerkinElmer is more than a lamp manufacturer – it actively participates in the advancement of flashlamp technology through its connections with research establishments throughout the world, both at university and commercial levels.

# Lamp Construction and Material Selection

## ENVELOPE MATERIALS

The term 'envelope' is universally used to describe the body or jacket surrounding the electrodes necessary to contain the filling gas. The chosen envelope material has to be transparent and able to transmit the useful light or radiation produced by the lamp. It must also be impervious to air and the filling gas, withstand high temperatures and be mechanically strong. The material universally used for envelopes in the construction of flashlamps and arc lamps for laser pumping is transparent fused quartz. It meets all, or most of the stated requirements, is easily worked and is available in a wide range of sizes.

Hard glass or pyrex is used extensively for lamps operating under conditions of low average power. This includes signal beacons, low power stroboscopes and low power photographic applications, i.e. camera flash guns. Under the high power conditions required for laser pumping, glass simply cannot withstand the high thermal loading. Stress cracks will rapidly develop within the tubing leading to lamp failure. Quartz however is highly tolerant to thermal shocks. At red heat it can be plunged into cold water without damage and has a high softening point (1300°C). Pyrex softens at approximately 600°C.

There is frequent confusion surrounding the terminology used in quartz based products. Although the term quartz is frequently used, its usage is somewhat incorrect as it describes the basic mined, unrefined ore, not the final product. The correct term is clear fused silica. It is also referred to as vitreous silica, quartz glass, fused glass or silica quartz. The term quartz, although incorrect, has become synonymous with flashlamps and for ease of reference will be used in this booklet.

There are three major groups of quartz used in flashlamp construction, clear fused quartz, doped quartz and synthetic quartz. Although all of them have similar physical properties as regards temperature and strength they differ in their respective transmittance at the UV end of the spectrum, from 200 to 400 nm.

### Quartz Types

#### Clear Fused Quartz

This material is the basic building block for the majority of flashlamps. It has an upper operational limit of approximately 600°C and is readily available

in a wide range of sizes. The UV cut off commences at approximately 220 nm. The only major disadvantage of clear fused quartz is the problem of solarisation. This is the appearance of a purplish discolouration due to colour centres forming within the quartz. The colour centres are localities of ion impurities. These are thought to include ion, aluminium, germanium and some rare earths. Solarisation results in a broad band reduction in the transmittance of the quartz. The colour sites generally form during the high energy operation of flashlamps. It does not appear to occur under low power conditions.

Many flashlamp pumped laser systems use lamps made from clear fused quartz. It is not generally possible to predict whether a particular mode of operation will make a lamp more susceptible to solarisation. If problems are experienced with solarisation there are alternative types of quartz available to alleviate the problem.

#### Doped Quartz

The UV transmission properties of quartz can be modified by the incorporation of a dopant in the material. This dopant usually takes the form of cerium, or titanium oxides. The quartz still appears clear but as Figure A shows, the UV transmission has been modified. This modification is desirable when potentially damaging UV from the flashlamp must be eliminated. This includes, in the case of a lamp operating in free air, the elimination of ozone or the prevention of UV damage to Nd:YAG rods, reflectors, plastics and 'O' rings.

**Cerium Doped Quartz** Clear fused quartz doped with cerium oxide is finding increasing applications in flashlamps for laser pumping. The UV cut off at approximately 380 nm ensures that harmful UV is eliminated from the pump chamber. The UV absorption is accompanied by fluorescence in the visible spectrum. As some of this falls in the absorption bands of Nd:YAG an increase in laser efficiency can be expected. Significantly as cerium doped silica does not solarise it has very stable characteristics throughout lamp life making it a very desirable envelope material for flashlamps when laser pumping.



**Titanium Doped Quartz** Clear fused quartz doped with titanium oxide is available in many different grades, each one having a different UV cut off profile. It has similar characteristics to cerium doped quartz but suffers badly from solarisation and does not have the fluorescence characteristic. Once used extensively when UV filtering was required for flashlamps, it has all but been superseded by a cerium doped quartz. It is however frequently encountered in medical and sun ray type lamps and non laser flashlamps when ozone must be prevented.

### Synthetic Quartz

In addition to doped and undoped quartz tubing there is another type of quartz material available. This is high purity, man-made, synthetic quartz. It is widely specified when transmission down to 160 nm is required. It generally has superb optical qualities and complete freedom from solarisation. It is the most expensive of all the quartz materials and the least readily available.

### General Considerations

Quartz tubing with 1 mm wall thickness is the most frequently specified for flashlamps. This, over a wide range of sizes, gives a good compromise between mechanical strength, availability, ease of lamp manufacture and lamp thermal properties. At internal diameters greater than 12 mm the wall thickness should be increased to 1.25 to 1.5 mm. Quartz thickness above 2.5 to 3 mm is not desirable as high

thermal gradients can be formed in the quartz during lamp operation, possibly leading to the formation of stress cracks. Under conditions of high average power and low peak power, e.g. krypton arc lamps, 0.5 mm wall thickness quartz is specified for maximum heat transfer from the lamp and to minimise the thermal gradient.

The internal diameter of quartz tubing is normally available in whole mm increments. Intermediate sizes can be obtained if required. A general purpose tolerance for flashlamp tubing is  $\pm 0.3$  mm for the outside and inside diameters. For small lamps of 2 to 4 mm bore and up to 75 mm arc, precision bore tubing is available, giving good repeatability of lamp performance, especially lamp impedance. Generally the tolerance of quartz tubing becomes greater as the sizes increase.

### SEALS

Regardless of type, when constructing a flashlamp or arc lamp it is important that the final product shall be a hermetic structure, that is to say the quartz envelope and the electrode assembly must make a gas and vacuum tight seal. The seals commonly used in flashlamp construction fall into three categories – ribbon seal, solder (end cap) seal, and rod (graded) seal.

### Ribbon Seal

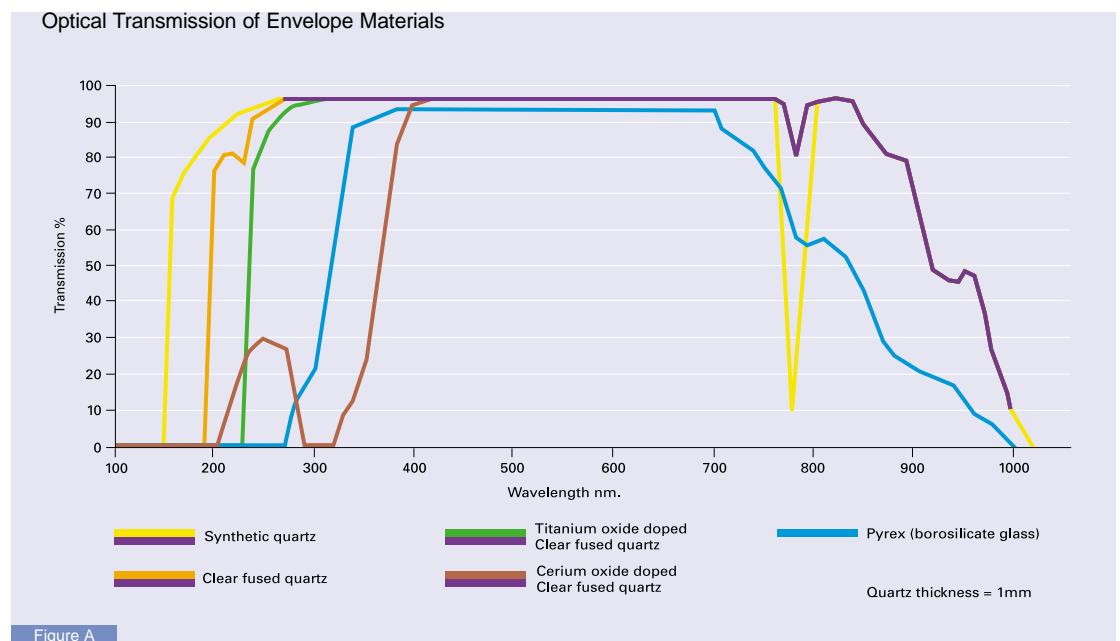

With this seal the quartz is bonded directly to a thin strip of molybdenum foil. This thin strip is necessary to prevent cracking of the seal due to the unequal expansion and contraction rates between quartz and molybdenum. As there are no intermediate sealing glasses used the full thermal potential of quartz can be realised. It is also a very robust and strong seal. One advantage of the ribbon seal is that lamps constructed using this technique have a minimised dead volume. The importance of this will be discussed later.

Ribbon seals have been extensively employed in the manufacture of high pressure mercury/xenon compact arc lamps. At least one manufacturer uses them for a series of krypton arc lamps. The limitation and disadvantage of lamps using ribbon seals is the low peak and RMS currents that can be passed through the thin molybdenum ribbons used in the seals, effectively precluding them from being used in pulsed flashlamps.

### Solder (End Cap) Seal

These seals use a technique that allows a bond to be made between a circular band of invar and the quartz tube that is the lamp envelope. The seal is made using a lead indium solder with a melting point of 350°C. Like the ribbon seal, lamps can be constructed with very small dead volumes. Other advantages include high mechanical strength over other seals and very high peak current capability, potentially the highest of all the seal types.

The disadvantage of the solder seal is its low service temperature, typically 100°C, this not only affects lamp operating conditions but also prevents any high temperature vacuum processing during manufacture. Also, long term shelf life is questionable due to the possible porosity of the solder seal. Ribbon or rod seals have a virtually unlimited shelf life.

### Rod (Graded) Seal

Among the group of seals that physically bond quartz/glass to metal is one universally known as the rod seal. This bonding is accomplished by a transition glass that is wetted to the un-oxidised surface of the tungsten, giving rise to its other name, the bright seal. This design is extensively used in flashlamps for solid state laser pumping because of its high reliability, high peak and RMS current capability.

This seal technology allows high temperature, high vacuum processing to be carried out during the evacuation and gas fill stages of lamp manufacture, thus ensuring a reliable product where batch to batch variation is kept to a minimum. Like the ribbon seal, virtually the full thermal potential of silica tubing can be realised.

Although short-term operation of the seal area at 600°C is possible, for long-term service temperatures must not exceed 300°C. At temperatures greater than 300°C oxidation of the tungsten lead-in wire will cause the seal to fail. When high peak currents and fast rise times are encountered, or large bore lamps are to be constructed, a useful and elegant variant of the rod seal called the re-entrant seal is used.

Examples of this seal are to be found in the QDX, QDF and the large bore QXA lamp series which appear in the second section of this publication. Here the seal is effectively under compression during the shock wave created by lamp operation.



## ELECTRODES

The most important component in a flashlamp is the cathode. The anode by comparison, providing the necessary design criteria are adhered to, is of minor importance in flash and arc lamp lifetimes. The choice of materials used in the construction of electrodes for flashlamps and arc lamps has to be made very carefully. At the anode the main concern is power loading due to electron bombardment from the arc, whilst the cathode must be able to supply an adequate amount of electrons (low work function) without damage to its surface (sputtering).

### Cathodes

Cathodes are commonly constructed using some type of dispenser method. This typically takes the form of a porous tungsten matrix filled with a barium based compound to give a low work function. Most manufacturers have their own proprietary methods for producing these cathodes although the ancestry of most of these can be traced back to the original Philips' cathode.

There are many cathode variations available from which the lamp designer may choose, each having a particular merit making it appropriate for a particular application. For example the designer may specify a cathode having an abundant availability of emissive compounds for use in a DC arc lamp, but when specifying a cathode for a high peak power application, a cathode with a





limited amount of emissive compound would be chosen. Cathodes need to be chosen with extreme care for operation in the millisecond regime as the arc can strip off large amounts of cathode material, drastically shortening lifetime.

PerkinElmer has devised a number of proprietary cathodes that offer outstanding lifetimes under these harsh conditions.

### Anodes

The main criteria the designer has to consider when specifying the anode design for a flashlamp or arc lamp is that it has a sufficient mass or surface area to cope with the given power level. Anodes are made from either pure tungsten or lanthanated tungsten, the latter being frequently chosen as the lanthanum content improves its machinability.

### Other Considerations

The shape of a flashlamp electrode is generally determined by the service conditions it will encounter. The most striking example being the difference between a DC krypton arc lamp and a pulsed xenon flashlamp. In the case of the arc lamp, the cathode is pointed, not only to ensure arc attachment well away from the walls of the lamp, but also to create the correct temperature necessary for true thermionic emission. On the other hand the pulsed xenon flashlamp generally employs a cathode with a flattened radius.

Every attempt is made to prevent the formation of hot spots that could give rise to the sputtering of cathode material during operation. These considerations are necessary given that a pulsed device could possibly be handling peak currents in excess of 1,000 amps, whereas the DC arc lamp is operating under steady state conditions of 15 to 40 amps.

Another difference encountered in electrode design is that dictated by low and high average power operating conditions. In the case of low average power operation there will be very little heating effect at the electrodes, although peak powers can be extremely high. Consequently the electrode structures can be quite small. Examples of these electrode styles are to be found in the QXA range of flashlamps in the second section of this publication. For high average power operation provision has to be made to extract as much heat as possible from the electrode. This is generally achieved by shrinking a portion of the lamp envelope on to the electrode surface. Examples of this type of construction are to be found in the QXF range of flashlamps in the second section of this publication. To cool the elec-

trodes under these high average power conditions demineralised water is channelled over the lamp's surface, thus removing heat not only from the electrodes but also from the envelope itself.

Providing adequate vacuum degassing has been carried out during lamp manufacture it is relatively unimportant how hot the anode runs during operation. On the other hand it is of paramount importance that the cathode is not allowed to overheat as this will seriously reduce lamp lifetime.

## COOLING CONSIDERATIONS

Lamps operated at low input energies and at low flash rates seldom require special cooling considerations. Heat from the lamp envelope and electrodes is lost by natural radiation. However, as the input power and the flash rate is increased there will come a point where some method of accelerating heat removal from the lamp must be considered. Most commercial pulsed Nd:YAG lasers and all DC arc lamp pumped Nd:YAG lasers require liquid cooling. Liquid cooling is normally achieved by flowing demineralised water over the lamp at approximately 4-10 litres per minute. The water is channelled over the lamp by use of a 'flow tube'.

All envelope materials have a maximum power loading that is expressed in watts/cm<sup>2</sup>. This maximum not only depends on whether it is convection, forced air or liquid cooled but also on the type of quartz used. When liquid cooling is specified, deionized water has been found the most suitable. Ordinary tap water is not usable as it is highly conductive and will short out the trigger pulse causing unreliable lamp operation. In addition it will cause severe electrolysis when lamp connectors are totally immersed in the coolant, e.g. DC krypton arc lamps. The water must have a resistivity of 200 kOhms or greater. Only stainless steel and plastic components can be used in the water circuit.

When forced air-cooling flashlamps, the air blast must extend to the ends of the lamp and include the seals and connectors. Preferably the air should be filtered. Forced air cooling is not often encountered in Nd:YAG laser pumping applications.

### Power Loadings

The cooling requirement for flashlamps and DC arc lamps used for laser applications are well defined. To determine the method necessary for correct lamp cooling, divide the average input power in watts into the internal wall area (cm<sup>2</sup>) bounded by the arc length. The resulting quotient is in watts per cm<sup>2</sup>.

**If between**

0-15 watts/cm<sup>2</sup> convection cooling is sufficient

15-30 watts/cm<sup>2</sup> forced air cooling is recommended. Liquid cooling should be considered at 15 watts/cm<sup>2</sup> if lamp is operated in a confined environment i.e. laser pump cavity

30-320 watts/cm<sup>2</sup> liquid cooling must be used

**The approximate upper limits for various envelope materials are:**

Doped quartz (UV absorbing) 1 mm wall thickness, 160 watts/cm<sup>2</sup>

Clear fused quartz 1 mm wall thickness, 200 watts/cm<sup>2</sup>

Synthetic quartz 1 mm wall thickness, 240 watts/cm<sup>2</sup>

Clear fused quartz 0.5 mm wall thickness, 320 watts/cm<sup>2</sup>

Loadings assume xenon gas fill. Due to higher internal temperatures derate by 10% for krypton.

In fluid cooled applications with adequate cooling of electrodes the quoted permissible wall loadings are often exceeded by large margins. Conversely, as these loadings are for new lamps, they will require derating as they age, or a safety margin built in to allow for absorption due to sputtered deposits from electrodes or solarization.

Failure to adequately cool flashlamps will result in unreliable operation and shortened lifetimes.

**FILLING GAS AND PRESSURE**

Xenon and krypton are normally chosen as the filling gases for DC and pulsed flashlamps. Xenon is more commonly encountered because of its higher overall conversion efficiency, especially when used in lamps for pulsed solid state laser systems. However at low power densities, krypton provides a better match to Nd:YAG than xenon. This is due to the excellent overlap between the absorption bands of YAG and the strong line radiation from low power density krypton, even though the overall efficiency is poorer than xenon.

Examples of lamps that exploit this effect are the QCW krypton arc lamps and the QJK pulsed krypton flashlamps.

**Fill Pressure**

Generally the higher the fill pressure the higher the efficiency for laser pumping. For pulsed lamps the highest practical pressure is approximately 3000 torr. Above this, triggering can be a major problem. Usually pressures greater than 760 torr are only found in small lamps (3-5 mm bore) operating at moderate power densities. Efficiency considerations aside, fill pressure can be altered to modify the lamp's electrical parameters, for example lower pressures allow for lower trigger and bank voltages, although at low pressures below 100 torr, cathode sputter can become a major problem.

The lamp's impedance characteristic is also affected by fill pressure – see Figure B.

Typical fill pressures encountered in flash and arc lamps are as follows:

General purpose flashlamps 450 torr xenon  
Krypton DC arc lamps 4 atmospheres  
Pulsed krypton flashlamps 700 torr  
Xenon compact arc flashlamps 1-3 atmospheres

**Dead Volume**

Earlier in the text, mention was made of the dead volume in a lamps construction. This is defined as the non-active internal area of the lamp, i.e. the internal volume from the electrode tip to the seal.

Although a lamp is manufactured with a given cold fill pressure in operation this pressure will rise as current density is increased. It follows that a lamp having a large dead volume will attain a lower pressure during operation than a lamp with a small dead volume and that the efficiency of the latter will be greater.

Dead volume effects are very important on high average power lamps, e.g. DC krypton arc lamps, high average power pulsed lamps and especially lamps where pulse durations exceed several milliseconds. In the case of a DC krypton arc lamp, consider two lamps, both having the same arc length and internal diameter, but differing on the amount of dead volume. Note that dead volume includes not only the area behind the electrode but also the length of the electrode. Both lamps can be made to operate with near identical volt ampere curves but the fill pressures can show as much as 2 atmospheres difference.



### Lamp Impedance – $K_0$

There are a number of ways to express lamp impedance. Perhaps the most common is the parameter  $K_0$ , this is shown as ohms ( $\text{amps}^{0.5}$ ).

$K_0$  is dependant upon lamp geometry (arc length and internal diameter), gas fill, and gas type. It is also influenced by lamp dead volume.

During lamp operation  $K_0$  will, given equal arc length, internal diameter and cold fill pressure, be lower in a lamp with a large dead volume than one with a smaller dead volume; due to the difference in the fill pressures of the lamps during operation.



It is important to realise that the values of  $K_0$  calculated from equation 2-3 are only a notional indication of the lamp's impedance as the calculation is performed only for the arc length and does not take into account any dead volume into which the fill gas can expand during lamp

operation, effectively preventing  $K_0$  from obtaining its calculated value. However, although this deviation is dependent on pulse duration, energy and arc diameter, in real terms only occasional problems are encountered between calculated and actual component values and operating voltages for correct lamp operation.

Figures B to D show how  $K_0$  scales against gas type, pressure, internal diameter (bore) and arc length.

It can be seen that  $K_0$  is inversely proportional to the lamp internal diameter ( $d$ ) not to  $d^2$  and that it is proportional to arc length.  $K_0$  is also a fairly weak function of pressure. For example, if in a given flashlamp it is necessary to change the fill gas from xenon to krypton, and maintain the same lamp impedance, then an approximate 70% pressure increase will be necessary for krypton, although there is only a 12% relative difference in the lamp impedance between xenon and krypton at the same pressure.

The  $K_0$  parameter is discussed further later in the text.

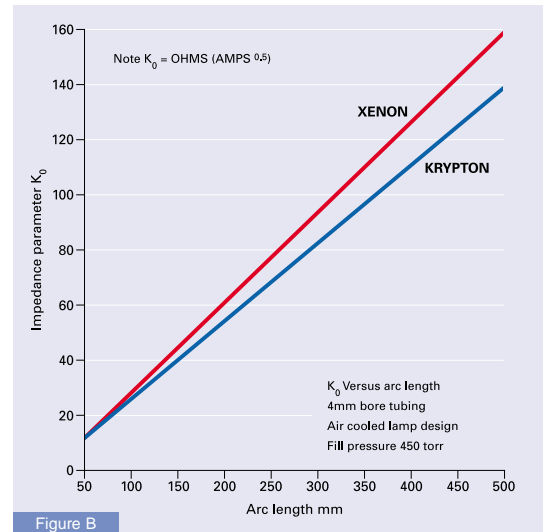

Figure B

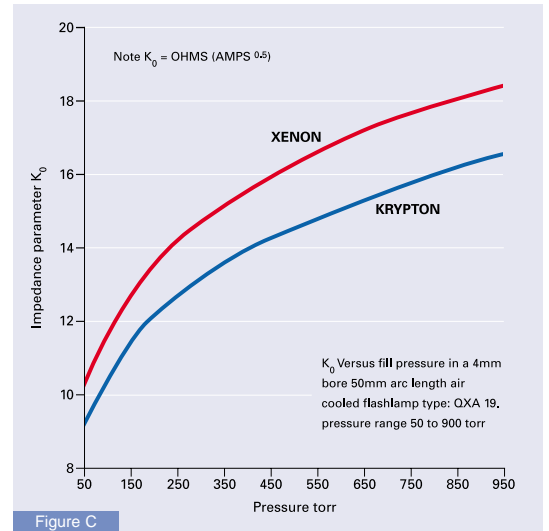

Figure C

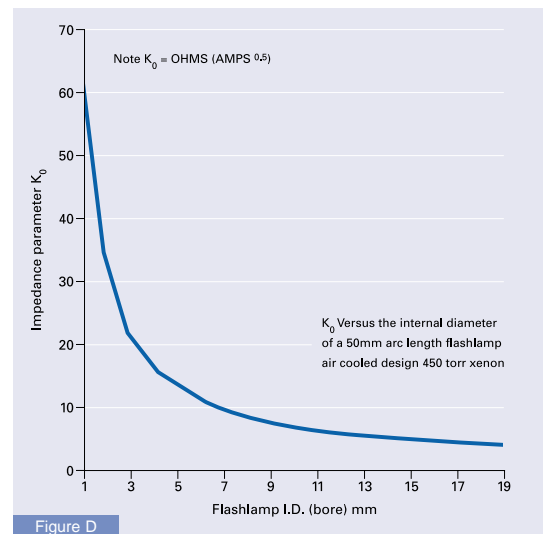

Figure D

## PLASMA PHYSICS

Although the physics of an arc plasma is complex, a basic model is presented in order to explain several dynamic properties of pulsed and DC lamps. Please refer to the following figure: "Cathode Sheath and Plasma Dynamics", Figure E.

Of the four states of matter, (solid, liquid, gas and plasma), plasmas operate at the highest observable temperatures. At the centre of the lamp axis, xenon and krypton temperatures may reach 10,000 Kelvin. This temperature falls rapidly in the radial direction where it may reach 1200 to 1500 Kelvin very near the surface of the quartz, which is below the softening point of 1940 Kelvin for  $\text{SiO}_2$ .

Because electrons are much more mobile than the positively charged  $\text{Xe}^+$  or  $\text{Kr}^+$  ions, they will be found in large concentrations near the inside surface of the quartz, making the inner wall electronegative. The electronegative attraction causes a migration of ions to the inner surface where electron-ion recombination occurs. The high electron-ion recombination at the inner wall results in a large population of neutral Xe or Kr atoms, which have a much lower temperature than ionized particles, and therefore acts as a thermal buffer between the arc plasma and the inner wall of the quartz.

Inside the arc plasma, three species of particles exist at any given time: electrons, positively charged ions and neutral atoms. The concentration of ionized atoms is less than 1% and accounts for all the emitted light energy. Ions travel from the anode to the cathode, while electrons travel from the cathode to the anode.

The damage observed at the cathode and anode are produced by different mechanisms. We will discuss only the effect upon the cathode. Very near the cathode surface, there exists a thin region,  $\delta$ , of ion current whose distance from the cathode surface to the light emitting region of the plasma is on the order of tens of microns. We call this the dark region. It is preoccupied with an abundance of ionized atoms which experience a voltage, called the sheath voltage,  $j_c$ . The sheath voltage may be five to fifteen volts and accelerates the ions into the cathode surface. The heavy ionized particles strike the cathode surface with enough energy to cause physical damage and is the primary limitation of cathode lifetime.

Finally, full voltage measured across a lamp while it is operating is the sum of the voltage drops across the anode and cathode electrodes, the anode and cathode sheath voltages and the plasma voltage.

## SPECTRAL OUTPUT

Flashlamps and arc lamps emit an optical

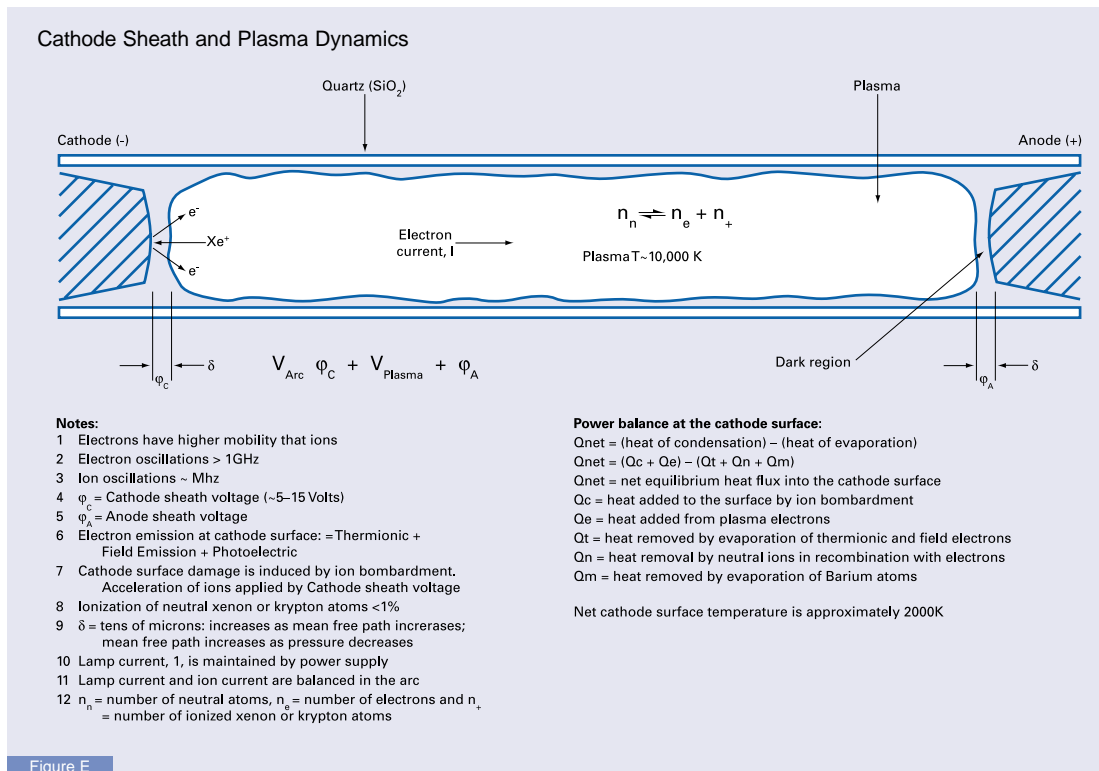



## OPERATIONAL CONSIDERATIONS

spectrum that covers a wide range of wavelengths. These extend from the UV cut off of the envelope material 160-381 nm, to the gradual IR cut off at approximately 2.5mm although the energy contained at these extremes is small.

The radiation produced by flash and arc lamps is primarily dependent on current density and to a lesser extent on the gas type and pressure (mercury and halide lamps excepted). At low current densities there is atomic line radiation corresponding to bound-bound energy state transitions. At higher current densities continuum radiation predominates resulting from free-bound and free-free transitions with the line structure now observed as small deviations in the spectrum dominated by continuum radiation. At high current densities the output approximates to a black body radiator of 9500°C.

### Efficiency

The conversion of electrical input power into radiated optical power for xenon flashlamps between 200 nm -1100 nm is approximately 50%. Generally the efficiency improves with increasing current density and gas fill pressure providing the lamps are operated from high efficiency impedance matched circuits. Xenon converts approximately 10% more electrical input power into radiated optical power than krypton.

### Spectral Output Graphs

Figures F to K show nominal spectral 'footprints' for xenon and krypton flashlamps and arc lamps under various conditions.

## TRIGGERING

In most flashlamp circuits the voltage on the energy

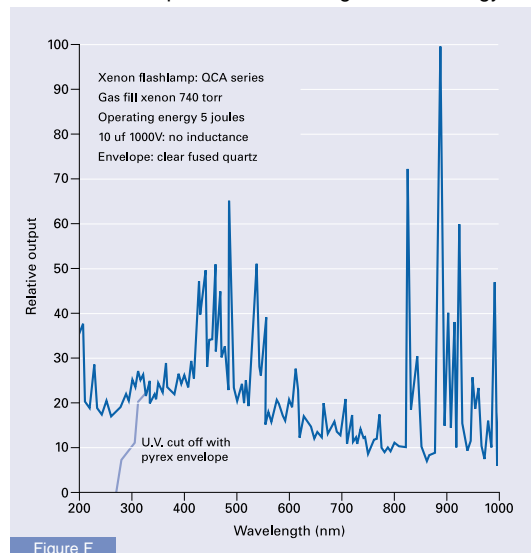

Figure F

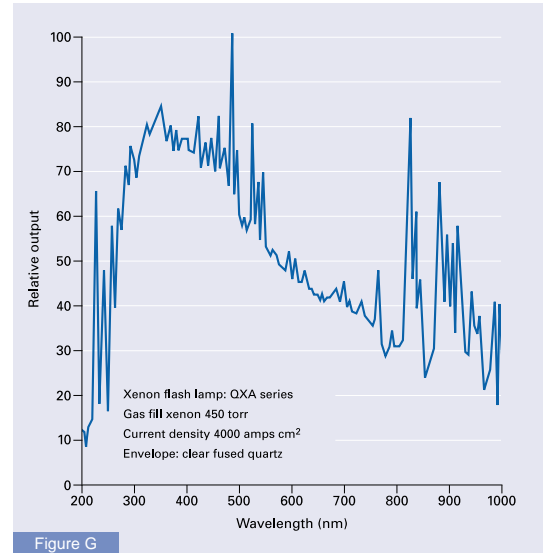

Figure G

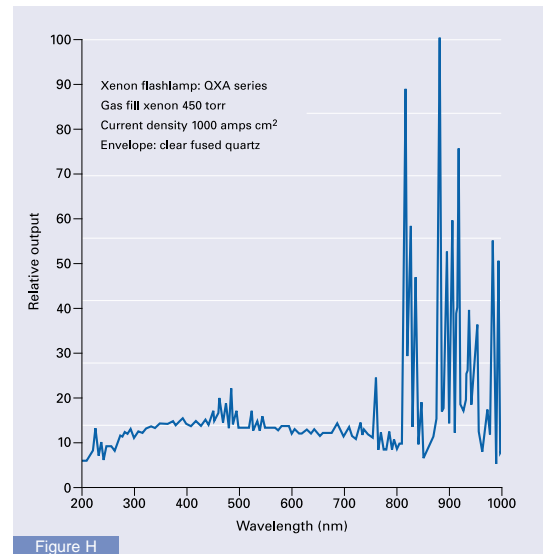

Figure H

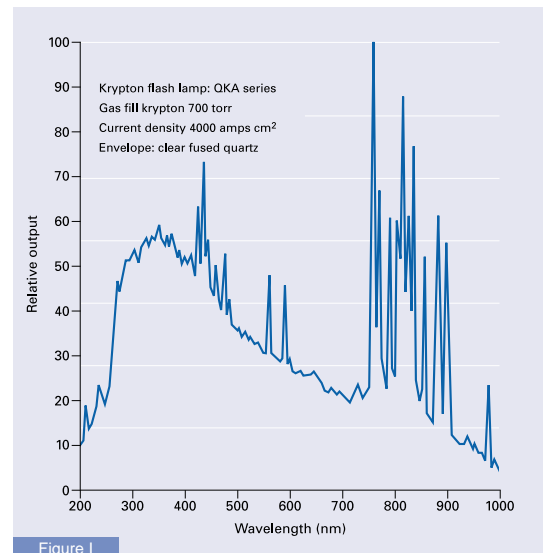

Figure I

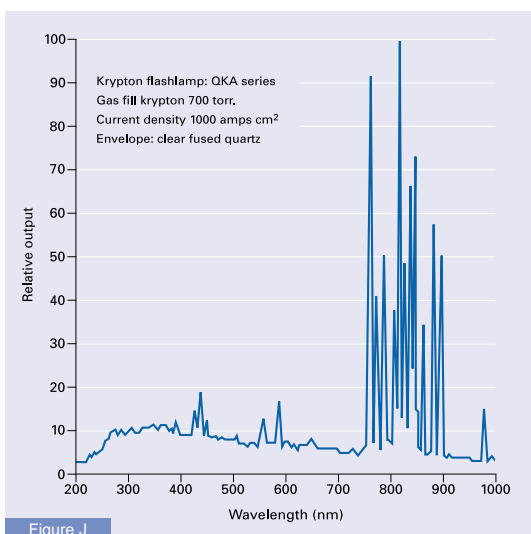

Figure J

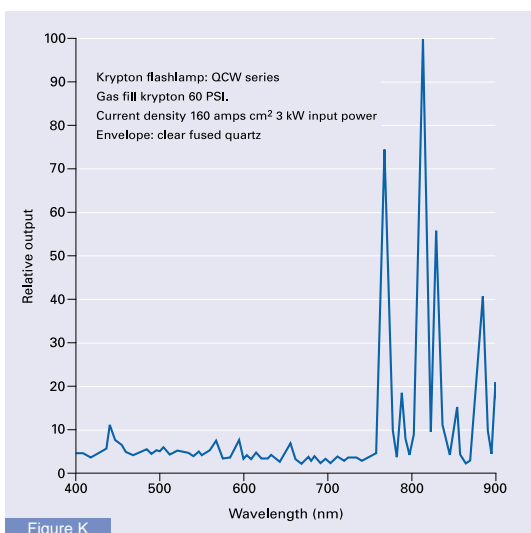

Figure K

storage capacitor is lower than the lamp self flash threshold. In common with other gas discharge devices flash and arc lamps exhibit extremely high resistance in their non-conducting state. In order for the lamp to conduct, a spark streamer is formed between the electrodes. This is accomplished by the application of a high voltage trigger pulse.

A number of trigger techniques in current use are shown in Figures M to T.

The trigger process occurs in several stages. Initially a spark streamer is formed between one or both electrodes and the inside wall of the lamp. This spark then propagates by capacitive effects along the inside wall of the lamp to the other electrode. If the voltage drop between the electrodes formed by this trigger streamer is lower than the capacitor voltage then the lamp will conduct.

Regardless of the trigger method used the process depends on the presence of a voltage gradient

or reference plane on or near the lamp's surface. Without it, reliable triggering cannot be guaranteed. This reference plane can take the form of a nickel wire wrapped round the outside of the lamp (external trigger) or the metallic structure of the laser cavity and cooling water (series trigger).

It is difficult to accurately define trigger pulse requirements. Not only must the trigger voltage be correct but also the length of time required for the trigger streamer to form has to be taken into account. This is generally 60 ns per cm of arc length. If the trigger pulse is not present for long enough, triggering will be erratic, even at high trigger voltages.

Each lamp type will have a different trigger curve similar to the one shown in Figure L. However, even with careful quality control during lamp manufacture, lamps of the same type, even from the same batch, will show some variation from the expected curve. The scatter will be greatest at the extremes of lamp V<sub>min</sub> and V<sub>max</sub>. Generally the trigger voltage should be at least 60% above that required to start most lamps of a given type.

In addition to having the correct trigger voltage, the relative polarity of the trigger and capacitor voltages should be observed as shown in Table 1.

### MODULATED CW AND QUASI-CW

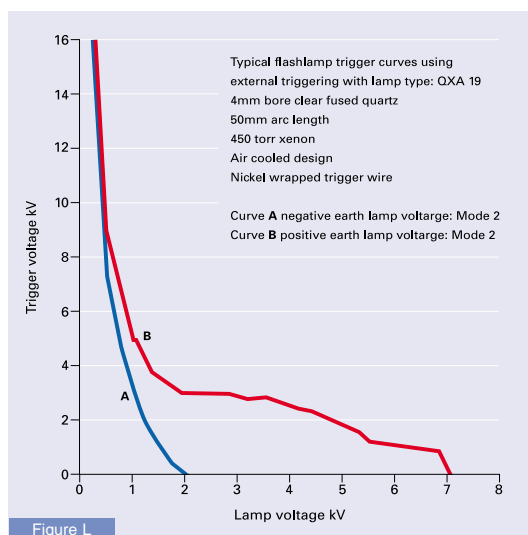

Figure L

Table 1

Trigger Mode	Common Electrode	Power Supply Polarity	Trigger Polarity External	Trigger Polarity Series
1	Cathode	Positive	Positive	Negative
2	Cathode	Positive	Negative	Positive
3	Anode	Negative	Positive	Negative
4	Anode	Negative	Negative	Positive

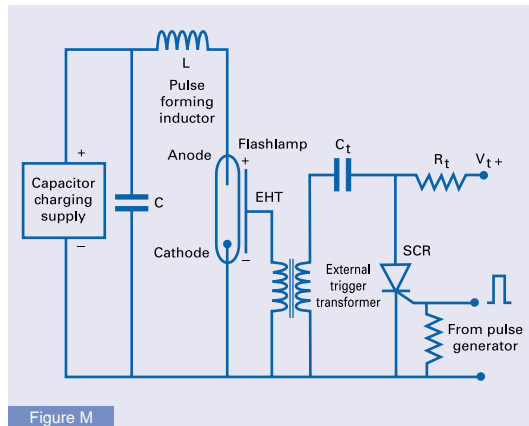

Figure M

### External Trigger

A high voltage trigger pulse from a step up trigger transformer is applied to nickel wire wrapped around the outside of the lamp; applicable to air cooled lamps only. It is the simplest cheapest and least difficult of all trigger methods to implement. The external trigger transformer is a small, lightweight component. External trigger permits greater circuit design flexibility as the transformer is outside the main discharge loop. External trigger is not often encountered in industrial solid state lasers, although it is used extensively for flashlamps used for photographic applications, stroboscopes, high speed fast rise time flashlamps and single shot low average power laser systems, i.e laser range finders. It's main disadvantage is that a high voltage is present on the outside of the lamp, making insulation difficult if, for example, the lamp is used in a metal laser cavity.

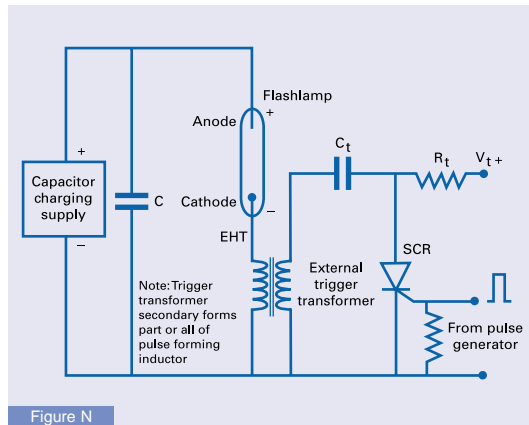

Figure N

### Series Triggering

The high voltage end of the series trigger transformer secondary is connected directly to one of the lamp electrodes. After triggering lamp current flows through the trigger transformer secondary, this acting as part or all of the pulse forming inductor. Consequently the series trigger transformer is a larger, heavier and expensive item compared to an external trigger transformer. Series triggering is used extensively in industrial high average power solid state laser systems. It offers better long term reliability compared to external triggering and has the advantage that no high voltages are present on the outside of the lamp. Triggering also takes place at lower capacitor charging voltages. As the trigger transformer primary has a very low impedance the trigger SCR must be able to handle high peak currents (greater than 1500 amps). Snubber components are usually incorporated to protect the SCR.

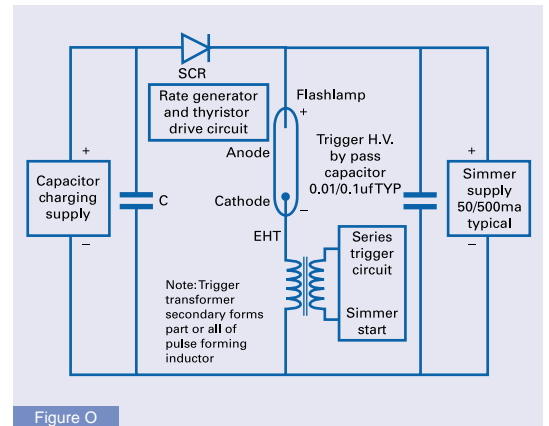

Figure O

### Simmer Operation

After triggering a low current DC discharge is maintained through the lamp (simmer). Typically this is 50-500 milliamps. Lamp pulsing is controlled by an SCR in the main discharge loop. Trigger methods (simmer strike) can be series or external. Simmer mode operation generally extends lamp lifetimes and is often used in high power, high repetition rate applications including most industrial solid state laser systems. Delay circuitry is normally needed in the capacitor charging supply in order to allow the SCR to fully turn off following lamp pulsing. Snubber components are normally required to protect the SCR peak. As the control SCR handles high peak and RMS currents it must be selected with care. Simmer current and voltage must be in the correct region of the lamp's VI curve if stable simmer is to be achieved. Simmer also offers higher laser pumping efficiency of up to 20% at low current densities. This advantage disappears at high current densities. Another benefit is improved pulse to pulse optical output stability.

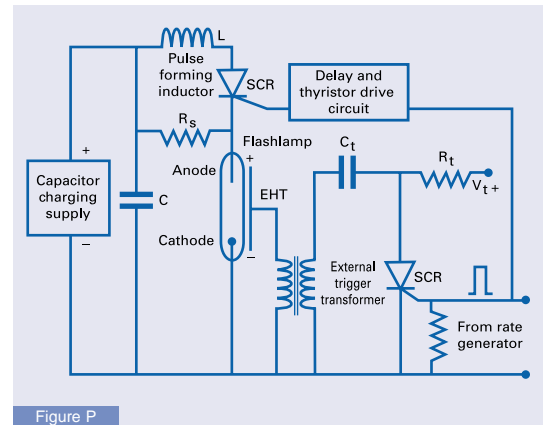

Figure P

### Pseudo Simmer

In portable equipment, or situations where the maintenance of a low current DC discharge through the lamp would be power prohibitive, many of the advantages of simmer operation can be obtained by using a technique known as pseudo simmer. The lamp is triggered conventionally using external or series triggering. Current from the energy storage capacitor is initially limited to approximately 50 milliamps by resistor Rs. After a delay of approximately 100-200ms Rs is shorted out by the SCR and the main discharge occurs. As lamp current flows through the SCR it must be selected with care. Snubber components are normally required to protect the SCR. Pseudo simmer is often used in laser range finders and other applications where improved pulse to pulse repeatability of light output is required. It also prevents the overheating of the relatively small cathodes used in convection cooled flashlamps that can occur when using normal simmer operation.

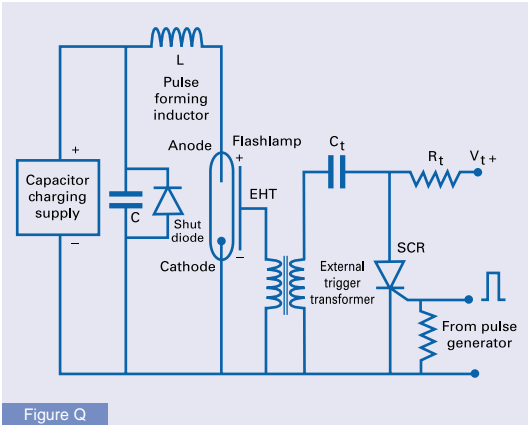

Figure Q

### Shunt Diode

It is desirable to choose capacitance, inductance and voltage to give a critically damped pulse at a given pulse duration. Generally with high impedance lamps normally used for YAG laser pumping this is never a problem. When it is not possible to design for critical damping and lamp current is oscillatory, a shunt diode across the energy storage capacity ensures that energy stored in the inductor (trigger transformer) is transferred through the lamp rather than back through the capacitor as negative voltage. The diode must be able to handle high peak and RMS currents. It should be connected directly across the energy storage capacitor and a 0.1 mf snubber capacitor connected across the diode to bypass high transient voltages. Typical lamp circuits requiring this kind of treatment are those operating compact arc flashlamps such as the QCA series.

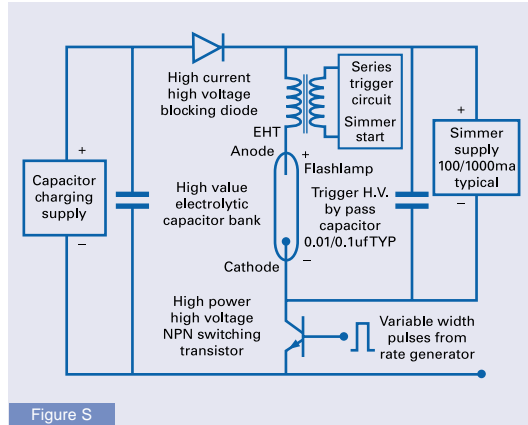

Figure S

### Variable Pulse Width Control

Stepless control over pulse duration is possible by running the lamp under simmer and using a high power, high current, high voltage NPN transistor to control lamp pulsing over a wide range of pulse durations; from 500 microseconds to over 20 milliseconds. The lamp is triggered using conventional series or external trigger techniques. Simmer current is normally in the range 0.5-3 amps. Snubber components will normally be needed across switching transistor and blocking diode. Care must be taken to prevent turn off transience associated with inductance in the trigger transformer. As control of pulse duration does not require inductance, external trigger can be used possibly by applying the high voltage trigger pulse directly to the cavity which is suitably insulated from ground. Note the use of floating simmer supply. Energy storage capacitors are electrolytic. Bank voltages are typically 300-600 volts. This lamp control technique is frequently used in high average power solid state laser systems.

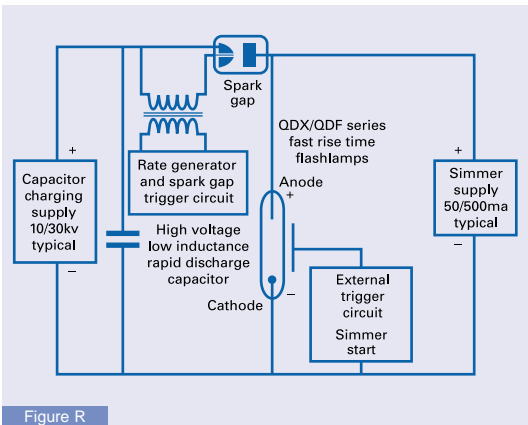

Figure R

### Fast Rise Time Operation

When high-energy short pulse durations are required (less than 10 microseconds), calculations normally indicate small values for the energy storage capacitor (typically 0.5-10 mf). Consequently capacitor voltage is frequently well above the lamp's self flash voltage threshold. The lamp must therefore be isolated from the storage capacitor until lamp pulsing is required. This is normally achieved by using a triggered spark gap ignatron or hydrogen thyratron (spark gap operation shown). Due to the high voltages and currents associated with high-energy short pulse duration operation, solid state switches (SCR) cannot normally be used. In order to obtain the fastest lifetimes all circuit inductance must be minimised. Longest lamp lifetimes under these harsh conditions are realised using simmer operations.

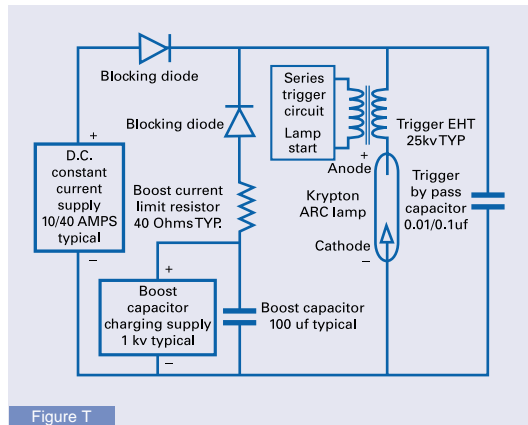

Figure T

### DC Krypton Arc Lamp Circuits

DC krypton arc lamps need special circuit design considerations for satisfactory lamp operation. These lamps undergo three distinct phases during start up, namely trigger, boost and current control. Initially a trigger streamer is formed between the lamp electrodes using series triggering. Lamp impedance at this point is very high and the voltage drop across the lamp electrodes is not low enough to allow current to flow from the constant current supply with its relatively low open circuit voltage (say, 200 volts). The boost phase provides the bridge between the high impedance trigger streamer and the low impedance running condition. In the boost phase a small capacitor (47-100 mf charged to approximately 1000 volts) is discharged through the lamp via a current limiting resistor. The trigger streamer now grows in diameter and current and lamp voltage drops to a point where the constant current supply is able to take over and control the lamp.





## OPERATION

CW lamps have recently proven to be effective for laser pumping and other applications when operated by the following two methods:

Modulated CW and Quasi-CW. Therefore, there are now alternatives to the standard DC krypton arc lamps commonly operated at a fixed current.

### Modulated CW

With this method of operation, a lamp is rapidly switched between a “simmer” current and a peak current; peak current is chosen for a particular application. When the lamp is not operational, a standby current is recommended. Peak current pulse durations are typically of the order of a few milliseconds, whereas the standby current may remain for several minutes. Duty cycles are commonly 50%. We recommend the following maximum and minimum values for the various currents given in Table 2. Figure U gives a typical pulse waveform for Modulated CW operation.

Table 2: Modulated CW Operating Parameters

Bore (mm)	Recommended Maximum Peak Current (Amps)	Recommended Nominal Peak Current (Amps)	Minimum “Simmer” Current (Amps)	Minimum Standby Current (Amps)	Recommended Maximum Wall Loading (Watt/cm <sup>2</sup> )
3	12	10	1	5	320
4	24	20	2	10	320
5	33	30	3	15	320
6	45	40	5	20	320
7	56	50	10	28	320
8	73	65	20	33	320

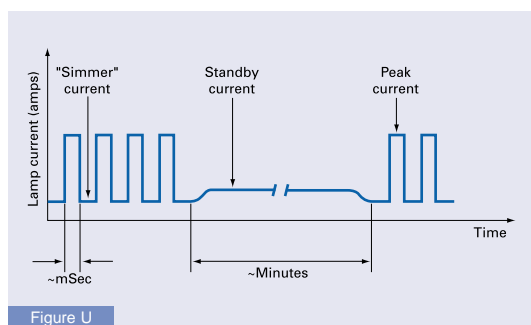

Figure U

### Quasi-CW

Quasi-CW is a term given to the mode of operation whereby the driving current is sinusoidal. The most cost effective means of operating a CW lamp in Quasi-CW mode is to use the line (mains) frequency or a multiple thereof. A typical Quasi-CW waveform is given below in Figure V. The “Depth of Modulation” is the deviation in current from the nominal value and the peak current. Depth of Modulation should not exceed 50% of the nominal. For best performance, lamps should not be operated above their recommended average power requirements.

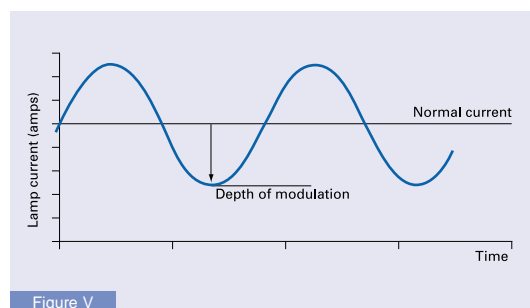

Figure V

## PULSED FLASHLAMP CIRCUIT CALCULATIONS

Many pulsed flashlamps are operated from inductor/capacitor single mesh pulsed forming networks (PFN's) or electronic switching. For PFN operation, the values of inductance (L), capacitance (C), and capacitor charging voltage ( $V_0$ ) are chosen to give a critically damped pulse of the desired duration and energy with a given lamp impedance ( $K_0$ ). The pulse shape under conditions of critical damping will have a near gaussian profile. It is generally desirable to operate lamp/PFN's under conditions of critical damping. This will ensure the maximum energy transfer between lamp and PFN, also maximizing lifetime.

For a given pulse width, energy and lamp impedance there is only one value of C, L and V that result in critical damping. The term  $a$  is conventionally taken to describe the pulse shape and is normally chosen to be 0.8 for critical damping.

If the lamp is to operate over a wide range of input energies, with C and L fixed ( $V_0$  varied to alter  $E_0$ ), the circuit should be designed for critical damping at the maximum energy; the circuit will then become over-damped as  $V_0$  is reduced.

## DESIGN PROCEDURE

The standard design procedure for flashlamp single mesh L/C drive networks was originated by J.P. Markiewicz and J.L. Emmett (reference 1).

The starting point for this design procedure is the volt ampere characteristic of a flashlamp that can be described as:

$$(1) \quad V = \pm K_o(i)^{0.5}$$

Where  $V$  = voltage across flashlamp (volts)

$i$  = discharge current (amps)

$K_o$  = impedance parameter

= ohms (amps)<sup>0.5</sup>

This equation is approximately true for current densities above 500 amps per cm<sup>2</sup>.  $K_o$  is the impedance parameter and is determined primarily by lamp arc length, internal diameter, gas type and fill pressure.

$$(2) \quad K_o = 1.28 (P/450)^{0.2} \text{ // } d \text{ (xenon)}$$

$$(3) \quad K_o = 1.28 (P/805)^{0.2} \text{ // } d \text{ (krypton)}$$

Where  $P$  = fill pressure (torr)

$l$  = arc length (mm)

$d$  = bore diameter (mm)

For low loss circuit conditions  $C$ ,  $L$  and  $V_o$  are calculated from the following equations:

$$(4) \quad C = \frac{[2E_o a^4 T^2]}{K_o^4}^{0.33}$$

$$(5) \quad L = T^2/C$$

$$(6) \quad V_o = (2E_o/C)^{0.5}$$

Where  $C$  = storage capacitor (farads)

$L$  = total circuit inductance (henries)

$E_o$  = stored energy (joules)

$a$  = damping parameter 0.8 for critical damping (reference 1)

$V_o$  = voltage on storage capacitor (volts)

$T$  = 1/3 of pulse width (seconds)

$$(7) \quad = (LC)^{0.5}$$

$$(8) \quad \text{total pulse duration} = 3(LC)^{0.5} \text{ at } 10\% \text{ current points}$$

Although equations (4), (5) and (6) make no allowance for arc dynamics (see reference 2) they are quite accurate for first order approximations, and are effective in predicting the shapes of current pulses.

The design steps are:

- With energy input, pulse duration and lamp  $K_o$  known  $C$  is found from equation (4).
- $L$  is then calculated from equation (5)
- Finally  $V_o$  is calculated from equation (6)

Damping parameter  $a$  is given by:

$$(9) \quad K_o / (V_o Z_o)^{0.5}$$

For critical damping in a low loss circuit the value assigned to  $a$  is normally 0.8. Practical limits are 0.7 – 1.1. Lower than 0.7 and current reversal is possible (circuit oscillatory, possible lamp damage). When using low impedance lamps and/or current reversal cannot be avoided use a shunt diode across the energy storage capacitor. See Figure Q.



Other relationships are:

$$(10) \quad \text{Peak current} = (V_o Z_o)/2 \text{ (amps)}$$

$$(11) \quad \text{Circuit impedance } Z_o = (LC)^{0.5} \text{ (ohms)}$$

$$(12) \quad \text{Stored energy} = C(V_o^2)/2 \text{ (joules)}$$

$$(13) \quad \text{Peak current density} = ipk/A \text{ (amps/cm}^2\text{)}$$

Where  $ipk$  = peak current (amps)

$A$  = lamp across sectional area (cm<sup>2</sup>)

The calculation of peak current from (10) frequently results in an over estimation of peak current. This is because no allowance has been made for flashlamp resistance. This can be calculated from:

$$(14) \quad R_t = \rho/l/A$$

Where:  $R_t$  = Flashlamp resistance (ohms)

$\rho$  = plasma resistivity

= 0.015 for  $T \cdot 100$  ms

= 0.02 for  $100$  ms >  $T \cdot 1000$  ms

= 0.025 for  $T > 1000$  ms

$A$  = cross sectional area of lamp (cm<sup>2</sup>)

$l$  = arc length in cm

$T$  = 1/3 of pulse width (ms)

Equation (10) can then be rewritten to include (14) giving a more accurate estimation of peak current, especially when lamp current is not critically damped.

$$(15) \quad \text{Peak current} = V_o / (Z_o + R_t) \text{ (amps)}$$



## RC CALCULATIONS

A number of non critical lamp applications do not use LC PFN's (eg photographic flash, stroboscopes etc.). Such configurations are referred to as resistance capacitance (RC) lamp circuits. It is often necessary to calculate pulse duration and peak current of RC lamp circuits. The general arrangement is:

$$(16) \quad T = R_1 C$$

$$(17) \quad \text{Peak current} = V_o/R_1 \text{ (amps)}$$

Where  $T$  = pulse duration at full width  $1/3$  height (seconds)

$R_1$  = Lamp resistance (ohms)

$C$  = capacitance (farads)

$V_o$  = voltage on storage capacitor (volts)

Although results from (16) and (17) cannot be regarded as accurate, they will provide "ball park" figures.

## CALCULATIONS AT SHORT PULSE DURATIONS

For the calculation of circuit conditions with lamps operating at short pulse durations use equations (4), (5) and (6) with the following notes:

- The calculated capacitor values will generally be larger than required for the chosen pulse duration. For total pulse duration in the range 1-10 ms reduce the calculated capacitance by 4. In 11-20 ms reduce by 2. These corrections appear to be on a sliding scale with large corrections below 1 ms. Recalculate for  $V_o$  with the new capacitor value.
- Assume total circuit inductance of approximately 1 mH. All unintentional inductance must be carefully controlled. QDX/QDF lamps can be supplied terminated with special coaxial cable.
- At short pulse durations the arc may never completely fill the lamp bore. The estimated diameter is approximately 50%-70% of bore diameter. This gives an apparent increase in the value for  $K_o$  accounting for the errors noted in (a).

## SIMMER VOLTAGE CALCULATIONS

It is very difficult to simply quantify simmer voltages. The standard equation  $V = \pm K_o (i)^{0.5}$  will not work under simmer conditions as the arc diameter does not fill the bore. The standard equation will predict simmer voltages far lower than test measurements would indicate. In order to make an approximation of simmer voltage we need to know the diameter of the arc for a given simmer current. We can then use this to modify impedance parameter  $K_o$  (it will become a much higher value) and thus predict a more accurate simmer voltage. The equations are simplifications of those given by Dishington (reference 2).

$$(18) \quad V_s = K_o(d/d_a) (i_s)^{0.5}$$

Where:  $V_s$  = Lamp simmer voltage

$K_o$  = Lamp impedance constant

$d$  = Lamp bore (ID)mm

$d_a$  = Arc diameter mm

$i_s$  = Simmer current amps

$$(19) \quad \text{Arc diameter } d_a \text{ is given empirically by: } d_a = (i_s)^{0.8} 1.8$$

The arrangement holds only while  $d_a$  is in the free arc regime. The transition point is approximately  $d \times 0.7$ .

It should be stressed that the answers obtained from this simple approach will be an approximation only. There are many factors that will affect any measured simmer voltage. These would include gas pressure increase due to temperature rise within lamp and also cathode condition. It is not uncommon to find simmer voltages varying by as much as 150 volts due to the arc attachment point moving around the cathode surface. This is most noticeable when relatively low simmer currents are being used (around 50 milliamps).

## KRYPTON ARC LAMP VOLTAGE CALCULATIONS

It is often necessary to predict lamp voltage or lamp input power as a function of varying lamp current. Figures W and X show measured and calculated voltage/current characteristics for two commonly used 4 and 6mm bore krypton arc lamps. In the range of normal operation the lamp is functioning in the region of positive resistance on its voltage/current characteristic. Under these conditions the discharge is wall stabilised and can be predicted by the following equation:

$$(20) \quad V = V_t - ((A_t - A) \times R_d)$$

Where  $R_d$  = Dynamic impedance and is given empirically by

$$(21) \quad (V_t/A_t)/3.25 - b$$

Other terms are:

$V$  = lamp voltage

$V_t$  = lamp voltage at test current

$A_t$  = test current

$A$  = desired lamp current

$R_d$  = dynamic impedance (slope)

$b$  = lamp bore in centimetres

$R_s$  = static impedance normally specified at full power and is  $V_t/A_t$

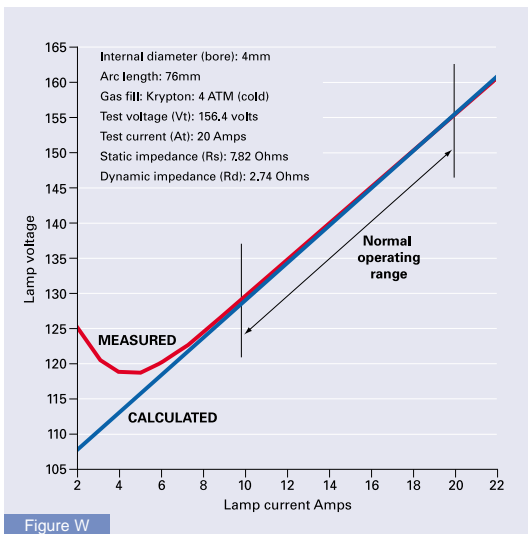

Figure W

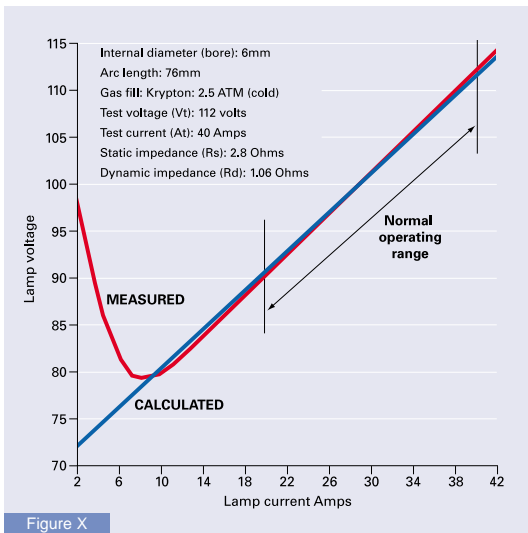

Figure X

$V_t$  and  $A_t$  are the only parameters needed to describe the volt/ampere characteristics of krypton arc lamps operating in the normal positive slope of their specifications. These measurements are normally taken at full power by the lamp manufacturer as part of the lamp test programme and are supplied with every lamp.

It will be noted that the equation is in error at the point where the arc diameter is contracting and the discharge is no longer wall stabilised. This occurs at approximately:

- 4 mm bore = 6 amps
- 5 mm bore = 8 amps
- 6 mm bore = 10 amps

Generally at these current levels the lamp will be operating well outside of its normal operating range. These errors are consequently of no significance.

## FLASHLAMP LIFETIME

There is no general method available for the reliable estimation of flashlamp lifetimes. In the high energy regime, see Figure Y it is possible to predict with reasonable accuracy the expected lifetime using equation 22. In this high energy regime lifetime is primarily determined by the mechanical strength of the quartz tubing and the amount of degradation caused within the lamp by ablation of the quartz material.

In the low energy regime of Figure Y lifetime is primarily determined by electrode effects, principally that of sputtered material from the cathode. The sputtered deposits will slowly build up on the inside wall of the lamp, reducing output. Here lifetime prediction using equation 22 would result in greatly over estimating lamp lifetime.

The curves of Figure Y give a general expectation of lifetimes in the low energy regime. Note the improvement with simmer operation.

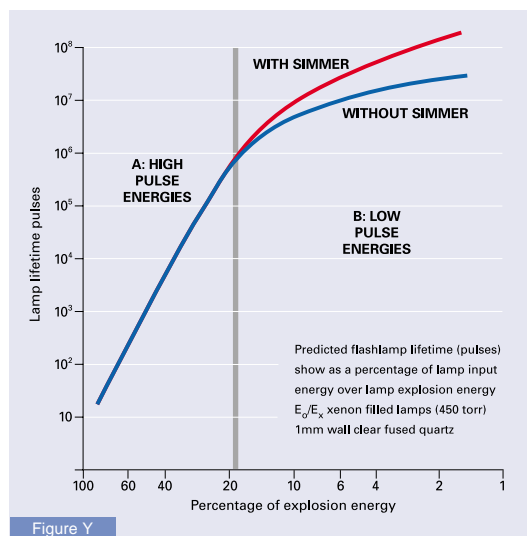
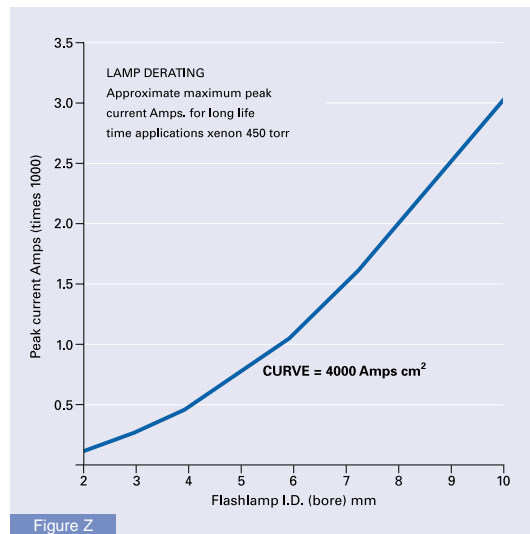

Figure Y

## LIFETIME EXPECTATIONS AT SHORT PULSE DURATIONS

The driving circuitry for fast rise time, short pulse durations must be designed very carefully in order to get the maximum lifetime from the lamp.

Fast rise time, short pulse duration lamps such as the QDX and QDF series are normally operated beyond their self flash voltage and use either a spark gap, thyatron or ignatron to control lamp pulsing. These lamps are operated by over volting, frequently coupled with simmer and prepulse techniques. Conventional external triggering is not normally possible or recommended for long lifetime applications.



Regardless of the method of circuitry chosen to operate fast rise time lamps the prime consideration is to ensure that arc growth starts from a centrally located position relative to the wall of the lamp. Simmer or prepulse techniques will generally ensure a central arc placement prior to the main pulse. External triggering, although the most simple and cost effective, guides the arc to the lamp wall. If the arc growth starts on or near the lamp wall, given time and with sufficient energy serious ablation or erosion of the silica will take place. This not only weakens the lamp but also results in considerable deposits forming on the inside wall of the lamp substantially reducing light output. In addition large amounts of oxygen are released by the decomposition of the silica affecting lamp triggering and jitter times.

## LIFETIME CALCULATIONS

### High Energy Regime

The standard method used to determine flashlamp lifetimes in the high energy regime is to show operating energy ( $E_o$ ) as a percentage of lamp single pulse explosion energy ( $E_x$ ).

$$(22) \quad \text{Life pulses} = (E_o/E_x)^{-8.5}$$

Where  $E_o$  = operating energy (joules)

$E_x$  = lamps explosion energy (joules)

For example:

Life Pulses	% $E_o/E_x$
$10^2$	0.58
$10^3$	0.44
$10^4$	0.33
$10^5$	0.26
$10^6$	0.197

For a given lamp with a given set of operating conditions ( $E_x$ ) can be calculated by using the single pulse explosion constant ( $K_e$ ).

$$(23) \quad E_x = K_e (T)^{0.5} \text{ (joules)}$$

Where  $K_e$  = lamp single pulse explosion constant

$T$  =  $1/3$  pulse width in seconds

$K_e$  can be taken from data sheets or from the following:

$$(24) \quad K_e = Q \times l \times d$$

Where  $Q$  = quartz tubing coefficient

24600 for  $d = 8$  mm

21000 for  $d = 10-12$  mm

20000 for  $d = 13$  mm

Where  $l$  = arc length (cms)

$d$  = bore diameter (cms)

Note: For QDX/QDF series lamps  $Q$  is doubled

For QHX series lamps  $Q$  is halved

### Low Energy Regime

At percentages of ( $E_o/E_x$ ) less than 0.197% or lifetimes greater than  $10^6$  we enter a region where life-time is determined by electrode effects and long term erosion of the quartz wall. Here any calculation made by (18) must be considered suspect at anything greater than  $3 \times 10^6$  pulses. Reliable estimations of lamp lifetime are difficult and are often based on a rule of thumb approach or situ testing under the given conditions. An example of the rule of thumb approach is the graph of Figure Y.

It is important to keep lamp peak currents at or below 4000 amps per  $\text{cm}^2$  for long lifetime applications if the long term erosion of quartz is to be avoided. See Figure Z.

## LAMP SELECTION

Assuming that the correct choice of lamp type has been made based on service requirements and assuming that pulse energy, pulse duration, arc length and lifetime have been set by system constraints, the dependant variable will be lamp bore. This may be determined from the following equations:

$$(25) \quad E_x = E_o / (L_p)^{1/8.5}$$

$$(26) \quad K_e = E_x / T^{0.5}$$

$$(27) \quad d = 4.06 K_e^{10^{-3}} / l$$

Where:  $E_x$  = Lamp explosion energy (joules)

$E_o$  = Operating energy (joules)

$L_p$  = Required lifetime pulses

$K_e$  = Single pulse explosion constant

$d$  = Lamp bore (mm)

$$l = \text{Arc length (mm)}$$

The procedure is:

- Determine lamp explosion energy from equation (25).
- Calculate single pulse explosion constant from equation (26).
- Calculate lamp bore from equation (27). If an intermediate size is calculated, e.g. 6.5 mm, select next whole number bore size – e.g. 7 mm. Quartz tubing is generally only available with whole number bore sizes in mm.

The procedure is useful for lifetimes in the high-energy regime i.e. to approximately  $3 \times 10^6$  (see Figure Y).

## POWER LOADING AND COOLING

To determine the cooling method necessary for correct lamp operation, lamp average power and wall loading must be determined.

$$(28) \quad P_{\text{ave}} = E_o f \text{ (watts)}$$

$$(29) \quad w_{\text{ave}} = P_{\text{ave}}/p/d \text{ (watts/cm}^2\text{)}$$

Where:  $P_{\text{ave}}$  = average power (watts)

$w_{\text{ave}}$  = average wall loading (watts/cm<sup>2</sup>)

$E_o$  = energy input to flashlamp (joules)

$f$  = pulse repetition rate (pulses per second)

$l$  = arc length (cm)

$d$  = lamp internal diameter (cm)

The maximum permissible loadings for flashlamps and DC arc lamps can be summarised as follows:

Wall loadings between:

0-15 watts cm<sup>2</sup> convection cooling can be used

15-30 watts cm<sup>2</sup> forced air-cooling is recommended. Liquid cooling should be considered at 15 watts cm<sup>2</sup> if lamp is operated in a confined environment i.e. laser cavity

30-320 watts cm<sup>2</sup> liquid cooling must be used

Upper limits for silica envelope materials:

Doped quartz (UV absorbing) 1 mm wall thickness  
160 watts – cm<sup>2</sup>

Clear fused quartz 1 mm wall thickness 200 watts – cm<sup>2</sup>

Synthetic quartz 1 mm wall thickness 240 watts – cm<sup>2</sup>

Clear fused quartz 0.5 mm wall thickness 320 watts – cm<sup>2</sup>

## SQUARE PULSE OPERATION

The method of operating krypton and xenon large bore flashlamps for many milliseconds per pulse has become commonplace in the industrial laser industry. The technique is recognized by several names and is used in many non-laser industries as well. As these names may suggest, Square Pulse, Long Pulse and High Charge-Transfer operation offer a means of delivering high peak and mean powers from krypton and xenon flashlamps.

Charge transfer may exceed several Coulombs

per pulse and high repetition rates (exceeding 300 Hz in some applications) are easily achievable. Pulse durations range from one to ten milliseconds, depending on the application. Under such operating conditions, many kilowatts may be generated in a single water-cooled flashlamp.

Figure P shows a typical circuit configuration where energy storage is maintained in the capacitor, C. A small percentage of the stored energy is released during each pulse, (usually less than 10%) and the voltage is maintained by the capacitor charging supply between pulses. Current and voltage waveforms of a typical 1.5 millisecond Square Pulse appear in Figure AA.

PerkinElmer engineers and scientists have developed a class of advanced cathodes for Square Pulse lamp operation in recent years. These advancements are identified by our Series 2000 cathode technology. Lamp lifetimes have been increased by a factor of three to five in many instances due to our advanced state-of-the-art cathodes.

## K<sub>o</sub> DISCUSSION

Many electrical engineers have attempted to model the impedance of a lamp, called K<sub>o</sub>, using standard circuit simulation packages such as PSpice™. Unfortunately, one cannot accurately model the impedance of an arc plasma using a series or parallel combination of passive elements. This is because the plasma impedance is non-linear and changes with time for the case of a flashlamp.

### Non-linear Plasma Resistivity

What then is meant by the term K<sub>o</sub>? All plasmas exhibit a resistivity. Goncz<sup>1</sup> was the first to provide an accurate model for plasma resistivity in flashlamps in 1965. He showed that plasma resistivity is inversely proportional to the square root of current density. The non-linearity between lamp voltage and current, therefore, can be given by the empirical relationship,  $V=K_o I^{1/2}$ . However, this equation incorrectly implies that K<sub>o</sub> is a constant, much like resistance in conductors. Unlike metals, xenon and krypton atoms do not have conduction, or valence, electrons. The “resistance” to the flow of electrons in a gaseous plasma involves a very different collision mechanism than with conductors. Therefore, we look for a region in the V-I curve of a lamp’s plasma to approximate its impedance. From such observations, the expression for K<sub>o</sub> is well known and appears in the Pulsed Flashlamp Circuit Calculations section.

### Time-Dependence of Arc Growth

<sup>1</sup> J.H. Goncz, J. Appl. Phys. 36, 742 (1965)



Figure AA shows voltage and current measurements for a single 1.5ms square pulse in an 8mm bore, 152mm arc length, krypton flashlamp at 440 Torr.

By using the relation  $K_o = V/I^{1/2}$ , we produce the graph in Figure BB. One can readily see the linear region near 20 on the vertical scale. This region of constant lamp impedance is what we mean by  $K_o$ . In fact, the graph produces a meaningless result at 1.5ms where  $K_o$  nearly drops to zero. This is impossible and the dashed line provides the real result.  $K_o$  begins at a very high value just prior to a pulse, then drops rapidly as the plasma freely expands, then finds a linear region as the plasma encounters the inner wall of the tube. Near the end of the pulse, as the plasma column begins to collapse,  $K_o$  returns to a very high value at the end of the pulse indicated by the dashed line.

Therefore, lamp impedance is neither linear nor constant during a pulse. In the case of a wall-stabilized plasma, as described in the previous paragraph, there is a region of linearity which we refer to as  $K_o$ .

There is no table here, Figure AA relates to the graph headed 'Voltage/Current Waveforms' and Figure BB relates to the graph headed 'Lamp impedance'

Figure AA is also referred to under Square Pulse Technology – see below:

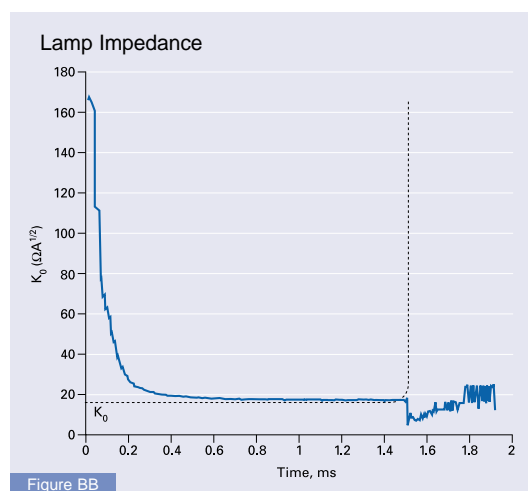
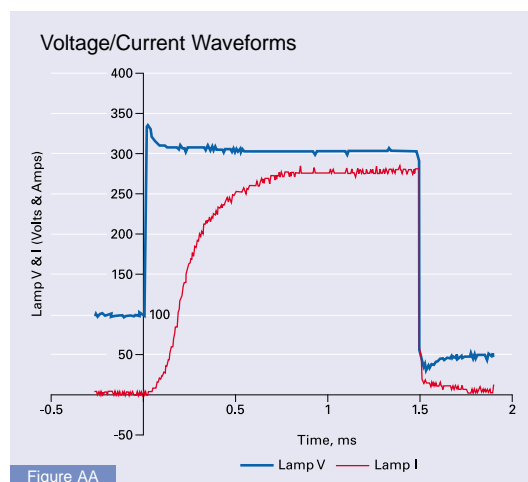

## REFERENCES

For further insight into the nature and operation of flashlamps the following references are suggested:

- Design of Flashlamp Driving Circuits – J. P. Markiewicz and J. L. Emmett. *Journal of Quantum Electronics* – Vol. QE-2 No. 1 1 (Nov. 1966).
- Flashlamp Discharge and Laser Efficiency – R. H. Dishington, W. R. Hook and R. P. Hilberg. *Applied Optics*. Vol. 13, No. 1 0 p. 2300 (October 1974).
- A Comparison of Rare-Gas Flashlamps – J. R. Oliver and F. S. Barnes I.E.E.E. *Journal of Quantum Electronics*, Vol. QE.5. No. 5 (May 1969).
- Flashlamp Drive Circuit Optimization for Lasers – R. H. Dishington – *Applied Optics* – Vol. 16, No. 6, p. 1578 (June 1977).
- Resistivity in Xenon Plasma – J. H. Goncz. *Journal of Applied Physics* – Vol. 36 Part 3, p. 742 (1965).
- Xenon Flashlamp Triggering for Laser Applications – W. R. Hook, R. H. Dishington and R. P. Hilberg. I.E.E.E. *Transactions of Electron Devices* E.D.19, p. 308 (March 1972).
- Prepulse Enhancement of Flashlamp Pumped Dye Laser – Michael H. Hornstein and Vernon E. Derr. *Applied Optics* – Vol. 13, No. 9 (Sept. 1974).
- Simmer-Enhanced Flashlamp Pumped Dye Laser – T.K. Yee, B. Fan and T.K. Gustafson. *Applied Optics* – Vol. 18, No. 8 (April 1979).
- A Simmered Pre-Pulsed Flashlamp Dye Laser – A. Marotta and C.A. Arquello. *Journal of Physics E: Scientific Instruments* – 1979 Vol. 9.
- Comparison of Coaxial and Preionized Linear Flashlamps as Pumping Sources for High Power Repetitive Pulsed Dye Lasers – A. Hirth, Th. Lasser, R. Meyer and K. Schetter. *Optics Communications* – Vol. 34 No. 2 (Aug. 1980).
- Design and Analysis of Flashlamp Systems for Pumping Organic Dye Lasers – J. F. Holzrichter and A. L. Schawlow. *Annals of the New York Academy of Sciences* 168, p. 703 (1970).
- A Versatile System for Flash Photophysics and Photodissociation Laser Studies – C. C. Davies and R. J. Pirkle. *Journal of Physics E. Scientific Instruments*, Vol. 9, p. 580 (1976).

The following book reference will provide useful background information on flashlamps and light production in general:

Sources and Applications of Ultra Violet Radiation – Roger Phillips. Published by Academic Press.

Electronic Flash Strobe – Harold E. Edgerton. Published by MIT Press.

Solid State Laser Engineering – Waiter Koechner. Published by Springer-Verlag.

Pulsed Light Sources – I. S. Marshak. Published by Plenum Publishing Corporation New York.

# Product Range

## LAMP INDEX

<b>QXA SERIES</b>	Page 22	<b>QXF MINIATURE SERIES</b>	Page 31
Air cooled, xenon filled flashlamps for low average power, medium peak power pulse operation.		Miniature liquid cooled, xenon flashlamps for high average power, medium peak power operation.	
<b>QXF SERIES</b>	Page 24	<b>QJK SERIES</b>	Page 32
Liquid cooled, xenon filled flashlamps for high average power, medium peak power operation.		Liquid cooled, krypton filled flashlamps, for high average power, low peak power operation at pulse durations in the millisecond regime.	
<b>QCW SERIES</b>	Page 26	<b>QXA RING SERIES</b>	Page 33
Liquid cooled, high pressure krypton arc lamps for C/W (DC) operation.		Air cooled ring format xenon flashlamps for low average power, medium peak power operation.	
<b>QDX SERIES</b>	Page 28	<b>QXA SOURCE LAMPS</b>	Page 33
Fast rise time, high peak power, low average power xenon filled flashlamps.		Air cooled, high intensity, high stability xenon flashlamps for instrumentation and laboratory use.	
<b>QDF SERIES</b>	Page 29	<b>QCA SERIES</b>	Page 34
Fast rise time, high peak power, high average power, liquid cooled xenon flashlamps.		Air cooled, compact arc xenon flashlamps for pulsed and high stability C/W (DC) operation.	
<b>QXA MINIATURE SERIES</b>	Page 30	<b>QHX SERIES</b>	Page 37
Miniature air cooled, xenon flashlamps for low average power, medium peak power operation.		Air cooled, xenon filled helical flashlamps.	

## LAMP PARAMETER DEFINITIONS

**Lamp Model number**  
Lamp type and identification number.

**Outline**  
Refers to lamp drawing.

**Bore Diameter**  
Internal diameter of lamp in mm.

**Quartz Length**  
Length of lamp seal to seal in mm.

**Overall Length**  
Length of lamp from connector to connector in mm.

**Base Size**  
Refers to electrical connector dimensions in mm.

**$K_o$**   
Lamps impedance parameter in ohms (amps)<sup>0.5</sup>.

**$K_e$**   
Single pulse explosion constant watts (seconds)<sup>0.5</sup>.

**$E_o$**   
Pulse energy in joules.

**T**  
1/3 total pulse width (seconds).

**Maximum Average Power**  
Maximum long-term lamp input power in watts.

**Maximum Peak Current**  
Suggested maximum peak pulsed current (amps) not to be exceeded when long lifetimes are required under conditions of high average power.

**$V_{min}$**   
Minimum lamp voltage for reliable operation when using external trigger. Defined as 300V + 40V per cm of arc length. With series trigger  $V_{min}$  = 25 volts per cm. Assumes fill pressure 450 torr xenon.

**$V_{max}$**   
Maximum lamp voltage for reliable operation without self flash = 3.5 x  $V_{min}$ . Assumes negative ground supply and fill pressure 450 torr xenon.  $V_{max}$  will be higher with positive ground supply.

**Minimum Trigger Voltage**  
Trigger voltage (in kV) and trigger pulse duration (in ms) should be at or above the specified maximum when lamp voltage  $V_{min}$ . As lamp voltage is increased trigger voltage decreases. (See Figure L).

**Additional Definitions**

### Krypton Arc Lamps

**Maximum Arc Current**  
DC arc current determined by lamp and electrode sizing (in amps).

**Maximum Arc Voltage**  
Voltage across electrodes at maximum current.

**Maximum Input Power**  
Maximum lamp input power in watts.

**Static Impedance ( $R_s$ )**  
Effective DC resistance (ohms) of lamp at full power.

**Dynamic Impedance ( $R_d$ )**  
Dynamic or slope resistance(ohms) used to describe voltage/current characteristics of DC arc lamps.

**Life Hours**  
Expected minimum lifetime at maximum power.

**QXA SERIES**

**Air Cooled, Xenon Filled Flashlamps for Low Average Power, Medium Peak Power, Pulse Operation**

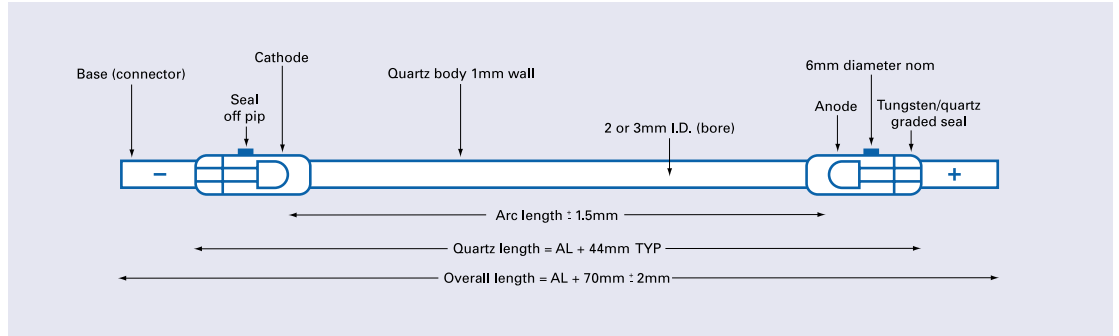

Bore Diameter (mm)	Arc Length (mm)	Overall Length (mm)	Base Size Dia/Length (mm)	Impedance Parameter $K_0$ Ohms-Amps <sup>0.5</sup>	Explosion Energy Const. $K_0^{0.5}$ Watts (sec)	Maximum Average Power – Watts		Operating Volts		Minimum Trigger Pulse	
						Convection	Forced Air	V min	V max	kV	msec
2	25	95	4.75/13	16.0	$1.23 \times 10^4$	24	48	400	1400	16	0.2
2	50	120	4.75/13	32.0	$2.46 \times 10^4$	47	94	500	1750	16	0.4
2	75	145	4.75/13	48.0	$3.69 \times 10^4$	71	142	600	2100	16	0.6
3	25	95	4.75/13	10.7	$1.84 \times 10^4$	35	70	400	1400	16	0.2
3	50	120	4.75/13	21.3	$3.69 \times 10^4$	71	142	500	1750	16	0.4
3	75	145	4.75/13	32.0	$5.53 \times 10^4$	106	212	600	2100	16	0.6
3	100	170	4.75/13	42.7	$7.38 \times 10^4$	141	282	700	2450	16	0.8

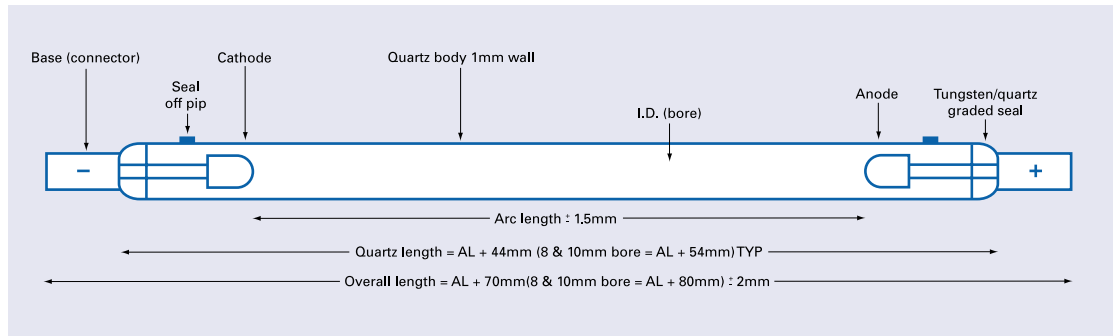

Bore Diameter (mm)	Arc Length (mm)	Overall Length (mm)	Base Size Dia/Length (mm)	Impedance Parameter $K_0$ Ohms-Amps <sup>0.5</sup>	Explosion Energy Const. $K_0^{0.5}$ Watts (sec)	Maximum Average Power – Watts		Operating Volts		Minimum Trigger Pulse	
						Convection	Forced Air	V min	V max	kV	msec
4	25	95	7.14/13	8.0	$2.46 \times 10^4$	47	94	400	1400	16	0.2
4	50	120	7.14/13	16.0	$4.92 \times 10^4$	94	188	500	1750	16	0.4
4	75	145	7.14/13	24.0	$7.38 \times 10^4$	141	282	600	2100	16	0.6
4	100	170	7.14/13	32.0	$9.84 \times 10^4$	189	378	700	2450	16	0.8
4	150	220	7.14/13	48.0	$1.47 \times 10^5$	283	566	900	3250	16	1.2
4	200	270	7.14/13	64.0	$1.96 \times 10^5$	754	754	1100	3850	16	1.6
5	50	120	7.14/13	12.8	$6.15 \times 10^4$	118	236	500	1750	16	0.4
5	75	145	7.14/13	19.2	$9.22 \times 10^4$	177	354	600	2100	16	0.6
5	100	170	7.14/13	25.6	$1.23 \times 10^5$	236	472	700	2450	16	0.8
5	150	220	7.14/13	38.4	$1.84 \times 10^5$	353	706	900	3150	16	1.2
5	200	270	7.14/13	51.2	$2.46 \times 10^5$	471	942	1100	3850	16	1.6
5	250	320	7.14/13	64.0	$3.07 \times 10^5$	589	1178	1300	4550	16	2.0
6	50	120	7.14/13	10.7	$7.38 \times 10^4$	141	282	500	1750	16	0.4
6	75	145	7.14/13	16.0	$1.10 \times 10^5$	212	424	600	2100	16	0.6

Bore Diameter (mm)	Arc Length (mm)	Overall Length (mm)	Base Size Dia/Length (mm)	Impedance Parameter $K_o$ Ohms-Amps <sup>0.5</sup>	Explosion Energy Const. $K_{0.5}$ Watts (sec)	Maximum Average Power – Watts		Operating Volts		Minimum Trigger Pulse	
						Convection	Forced Air	V min	V max	kV	msec
6	100	170	7.14/13	21.3	$1.47 \times 10^5$	283	566	700	2450	16	0.8
6	150	220	7.14/13	32.0	$2.21 \times 10^5$	424	848	900	3150	16	1.2
6	200	270	7.14/13	42.7	$2.95 \times 10^5$	566	1132	1100	3850	16	1.6
6	250	320	7.14/13	53.3	$3.69 \times 10^5$	707	1414	1300	4550	16	2.0
7	50	120	7.14/13	9.1	$8.61 \times 10^4$	165	330	500	1750	18	0.4
7	75	145	7.14/13	13.7	$1.29 \times 10^5$	247	494	600	2100	18	0.6
7	100	170	7.14/13	18.3	$1.72 \times 10^5$	330	660	700	2450	18	0.8
7	150	220	7.14/13	27.4	$2.58 \times 10^5$	495	990	900	3150	18	1.2
7	200	270	7.14/13	36.6	$3.44 \times 10^5$	660	1320	1100	3850	18	1.6
7	250	320	7.14/13	45.7	$4.30 \times 10^5$	825	1650	1300	4550	18	2.0
8	75	155	7.14/13	12.0	$1.47 \times 10^5$	283	566	600	2100	18	0.6
8	100	180	7.14/13	16.0	$1.96 \times 10^5$	377	754	700	2450	18	0.8
8	150	230	7.14/13	24.0	$2.95 \times 10^5$	566	1132	900	3150	18	1.2
8	200	280	7.14/13	32.0	$3.93 \times 10^5$	754	1508	1100	3850	18	1.6
8	250	330	7.14/13	40.0	$4.92 \times 10^5$	943	1886	1300	4550	18	2.0
8	300	380	7.14/13	48.0	$5.90 \times 10^5$	1131	2262	1500	5250	18	2.4
10	100	180	7.14/13	12.8	$2.10 \times 10^5$	471	942	700	2450	20	0.8
10	150	230	7.14/13	19.2	$3.15 \times 10^5$	707	1414	900	3150	20	1.2
10	200	280	7.14/13	25.6	$4.20 \times 10^5$	943	1886	1100	3850	20	1.6
10	250	330	7.14/13	32.0	$5.25 \times 10^5$	1178	2356	1300	4550	20	2.0
10	300	380	7.14/13	38.4	$6.30 \times 10^5$	1414	2828	1500	5250	20	2.4
10	450	530	7.14/13	57.6	$9.45 \times 10^5$	2121	4242	2100	7350	20	3.6

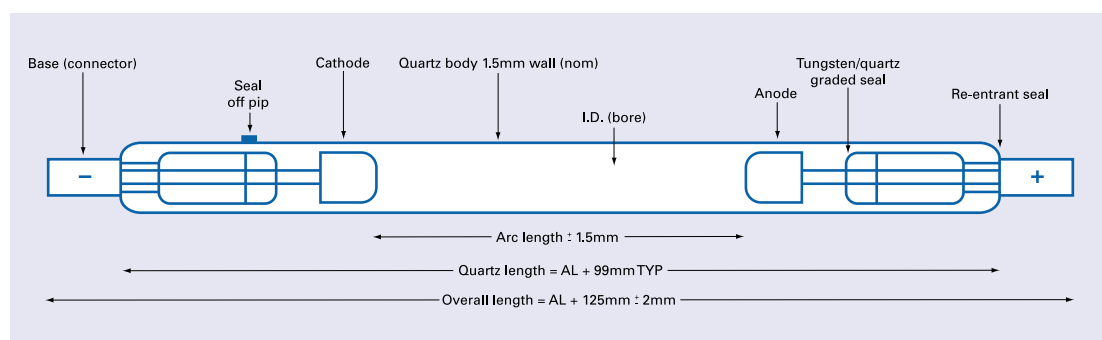

Bore Diameter (mm)	Arc Length (mm)	Overall Length (mm)	Base Size Dia/Length (mm)	Impedance Parameter $K_o$ Ohms-Amps <sup>0.5</sup>	Explosion Energy Const. $K_{0.5}$ Watts (sec)	Maximum Average Power – Watts		Operating Volts		Minimum Trigger Pulse	
						Convection	Forced Air	V min	V max	kV	msec
13	150	275	7.14/13	14.8	$3.90 \times 10^5$	919	1838	900	3150	20	1.2
13	200	325	7.14/13	19.7	$5.20 \times 10^5$	1225	2450	1100	3850	20	1.6
13	250	375	7.14/13	24.6	$6.50 \times 10^5$	1532	3064	1300	4550	20	2.0
13	300	425	7.14/13	29.5	$7.80 \times 10^5$	1838	3676	1500	5250	20	2.4
13	450	575	7.14/13	44.3	$1.17 \times 10^6$	2757	5514	2100	7350	20	3.6
13	600	725	7.14/13	59.1	$1.56 \times 10^6$	3676	7352	2700	9450	20	4.8
15	200	325	7.14/13	17.1	$6.00 \times 10^5$	1414	2828	1100	3850	20	1.6
15	250	375	7.14/13	21.3	$7.50 \times 10^5$	1767	3534	1300	4550	20	2.0
15	300	425	7.14/13	25.6	$9.50 \times 10^5$	2121	4242	1500	5250	20	2.4
15	450	575	7.14/13	38.4	$1.35 \times 10^6$	3181	6362	2100	7350	20	3.6
15	600	725	7.14/13	51.2	$1.80 \times 10^6$	4242	8484	2700	9450	20	4.8
15	900	1025	7.14/13	76.8	$2.70 \times 10^6$	6363	12726	3900	13650	20	7.2

## QXF SERIES

### Liquid Cooled, Xenon Filled Flashlamps for High Average Power, Medium Peak Power Operation

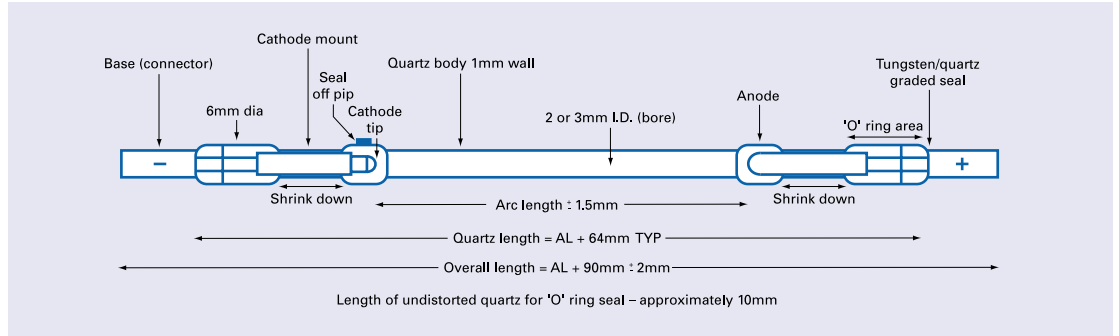

Bore Diameter (mm)	Arc Length (mm)	Overall Length (mm)	Base Size Dia/Length (mm)	Impedance Parameter $K_0$ Ohms-Amps <sup>0.5</sup>	Explosion Energy Const. $K_0^{0.5}$ Watts (sec)	Maximum Average Power (watts)	Maximum Average Power (amps)	Operating Volts		Minimum Trigger Pulse kV	Minimum Trigger Pulse msec
								V min	V max		
2	25	115	4.75/13	16.0	$1.23 \times 10^4$	314	125	400	1400	16	0.2
2	50	140	4.75/13	32.0	$2.46 \times 10^4$	628	125	500	1750	16	0.4
2	75	165	4.75/13	48.0	$3.69 \times 10^4$	943	125	600	2100	16	0.6
3	25	115	4.75/13	10.7	$1.84 \times 10^4$	471	280	400	1400	16	0.2
3	50	140	4.75/13	21.3	$3.69 \times 10^4$	943	280	500	1750	16	0.4
3	75	165	4.75/13	32.0	$5.53 \times 10^4$	1414	280	600	2100	16	0.6
3	100	190	4.75/13	42.7	$7.38 \times 10^4$	1885	280	700	2450	16	0.8

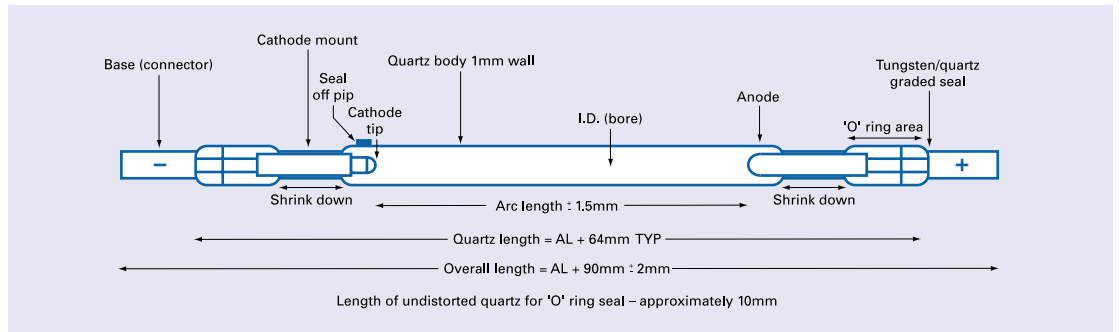

Bore Diameter (mm)	Arc Length (mm)	Overall Length (mm)	Base Size Dia/Length (mm)	Impedance Parameter $K_0$ Ohms-Amps <sup>0.5</sup>	Explosion Energy Const. $K_0^{0.5}$ Watts (sec)	Maximum Average Power (watts)	Maximum Average Power (amps)	Operating Volts		Minimum Trigger Pulse kV	Minimum Trigger Pulse msec
								V min	V max		
4	25	115	7.14/13	8.0	$2.46 \times 10^4$	628	500	400	1400	16	0.2
4	50	140	7.14/13	16.0	$4.92 \times 10^4$	1257	500	500	1750	16	0.4
4	75	165	7.14/13	24.0	$7.38 \times 10^4$	1885	500	600	2100	16	0.6
4	100	190	7.14/13	32.0	$9.84 \times 10^4$	2514	500	700	2450	16	0.8
4	125	215	7.14/13	40.0	$1.23 \times 10^5$	3142	500	800	2800	16	1.0
5	50	140	7.14/13	12.8	$6.15 \times 10^4$	1571	800	500	1750	16	0.4
5	75	165	7.14/13	19.2	$9.22 \times 10^4$	2357	800	600	2100	16	0.6
5	100	190	7.14/13	25.6	$1.23 \times 10^5$	3142	800	700	2450	16	0.8
5	125	215	7.14/13	32.0	$1.53 \times 10^5$	3928	800	800	2800	16	1.0
5	150	240	7.14/13	38.4	$1.84 \times 10^5$	4713	800	900	3150	16	1.2

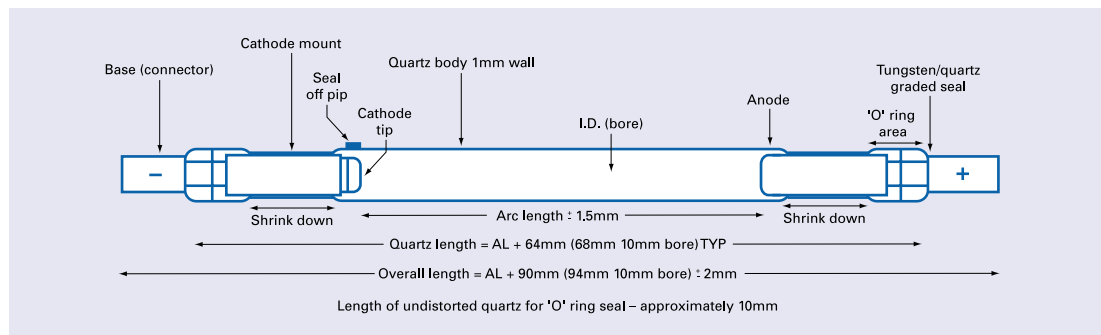

Bore Diameter (mm)	Arc Length (mm)	Overall Length (mm)	Base Size Dia/Length (mm)	Impedance Parameter $K_0$ Ohms-Amps <sup>0.5</sup>	Explosion Energy Const. $K_{0.5}$ Watts (sec)	Maximum Average Power (watts)	Maximum Average Power (amps)	Operating Volts		Minimum Trigger Pulse kV	msec
								V min	V max		
6	50	140	7.14/13	10.7	$7.38 \times 10^4$	1885	1100	500	1750	16	0.4
6	75	165	7.14/13	16.0	$1.10 \times 10^5$	2828	1100	600	2100	16	0.6
6	100	190	7.14/13	21.3	$1.47 \times 10^5$	3770	1100	700	2450	16	0.8
6	125	215	7.14/13	26.7	$1.84 \times 10^5$	4713	1100	800	2800	16	1.0
6	150	240	7.14/13	32.0	$2.21 \times 10^5$	424	1100	900	3150	16	1.2
6	200	290	7.14/13	42.7	$2.95 \times 10^5$	566	1100	1100	3850	16	1.6
7	75	165	7.14/13	13.7	$1.29 \times 10^5$	3299	1400	600	2100	18	0.6
7	100	190	7.14/13	18.3	$1.72 \times 10^5$	4399	1400	700	2450	18	0.8
7	125	215	7.14/13	22.9	$2.15 \times 10^5$	5499	1400	800	2800	18	1.0
7	150	240	7.14/13	27.4	$2.58 \times 10^5$	6598	1400	900	3150	18	1.2
7	200	290	7.14/13	36.6	$3.44 \times 10^5$	8798	1400	1100	3850	18	1.6
7	250	340	7.14/13	45.7	$4.30 \times 10^5$	10997	1400	1300	4550	18	2.0
8	75	165	7.14/13	12.0	$1.47 \times 10^5$	3770	1800	600	2100	18	0.6
8	100	190	7.14/13	16.0	$1.96 \times 10^5$	5027	1800	700	2450	18	0.8
8	125	215	7.14/13	20.0	$2.46 \times 10^5$	6284	1800	800	2800	18	1.0
8	150	240	7.14/13	24.0	$2.95 \times 10^5$	7541	1800	900	3150	18	1.2
8	200	290	7.14/13	32.0	$3.93 \times 10^5$	10054	1800	1100	3850	18	1.6
8	250	340	7.14/13	40.0	$4.92 \times 10^5$	12568	1800	1300	4550	18	2.0
8	300	390	7.14/13	48.0	$5.90 \times 10^5$	15082	1800	1500	5250	18	2.4
10	75	169	7.14/13	9.6	$1.57 \times 10^5$	4713	2800	600	2100	20	0.6
10	100	194	7.14/13	12.8	$2.10 \times 10^5$	6284	2800	700	2450	20	0.8
10	125	219	7.14/13	16.0	$2.62 \times 10^5$	7855	2800	800	2800	20	1.0
10	150	244	7.14/13	19.2	$3.15 \times 10^5$	9426	2800	900	3150	20	1.2
10	200	294	7.14/13	25.6	$4.20 \times 10^5$	12568	2800	1100	3850	20	1.6
10	250	344	7.14/13	32.0	$5.25 \times 10^5$	15710	2800	1300	4550	20	2.0
10	300	394	7.14/13	38.4	$6.30 \times 10^5$	18852	2800	1500	5250	20	2.4
10	450	530	7.14/13	57.6	$9.45 \times 10^5$	2121	4242	2100	7350	20	3.6



QCW SERIES

Liquid Cooled, High Pressure Krypton Arc Lamps for C/W (DC) Operation

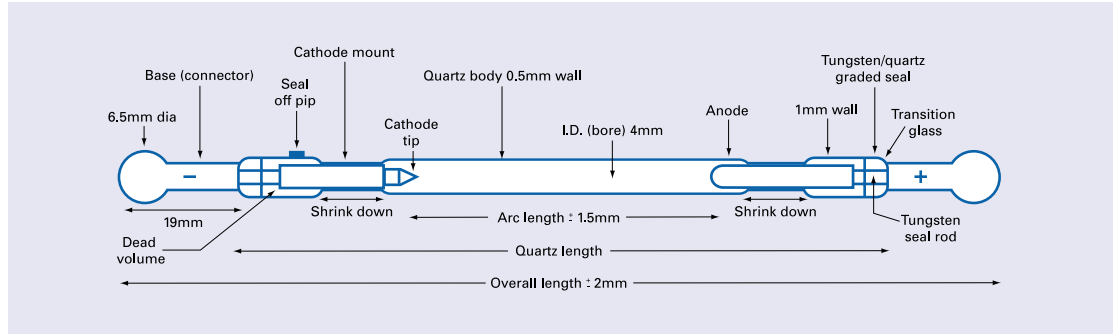

Bore Diameter (mm)	Arc Length (mm)	Overall Length (mm)	Base Size Dia/Length (mm)	Maximum Current (amps)	Maximum Arc Voltage at Maximum Current (volts)	Maximum Input Power (watts)	Static Impedance at Maximum Power (ohms)	Dynamic Impedance at Maximum Power (ohms)	Life at Maximum Power (hours)
4	51	191	balltype	20	110	2200	5.5	2.0	400
4	76	215	ball type	20	165	3300	8.3	3.0	400
4	76	180	ball type	20	160	3200	8.0	2.9	400
6	76	176	6.35/11	40	125	5000	3.1	1.1	400

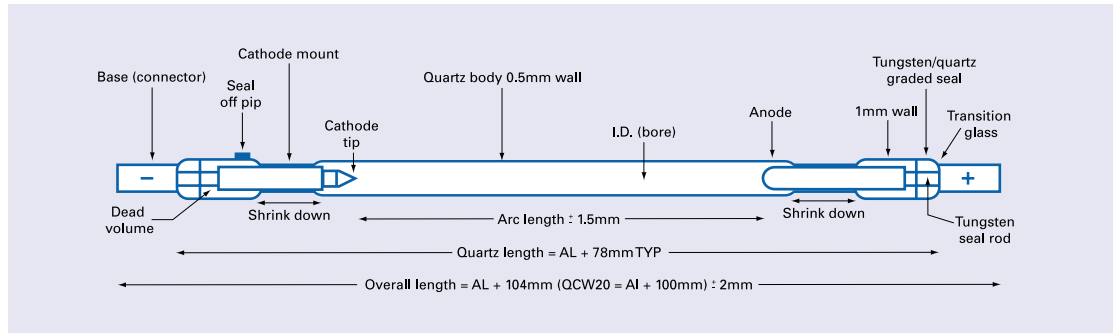

Bore Diameter (mm)	Arc Length (mm)	Overall Length (mm)	Base Size Dia/Length (mm)	Maximum Current (amps)	Typical Arc Voltage at Maximum Current (volts)	Maximum Input Power (watts)	Static Impedance at Maximum Power (ohms)	Dynamic Impedance at Maximum Power (ohms)	Life at Maximum Power (hours)
4	50	154	4.75/13	23	87	2000	3.8	1.4	300
4	75	179	4.75/13	23	130	3000	5.7	2.0	300
4	100	204	4.75/13	23	174	4000	7.6	2.7	300
5	50	154	4.75/13	32	81	2600	2.5	0.9	300
5	75	179	4.75/13	32	122	3900	3.8	1.4	300

To assist in the selection of alternative arc lengths the operating parameters are shown in units per centimetre. These parameters are multiplied by the desired arc length to obtain lamp data.

	Bore Diameter (mm)	Maximum Current (amps)	Typical Voltage Drop at Maximum Current (volts per cm)	Maximum Input Power (watts cm)	Static Impedance at Maximum Power (ohms per cm)	Dynamic Impedance at Maximum Power (ohms per cm)	Life at Maximum Power (hours)
Standard Pressure	4	23	17.4	400	.76	.27	300
	5	32	16.3	520	.51	.18	300
	6	44	15.9	700	.36	.13	300
	7	52	15.4	800	.30	.11	300
High Pressure (high efficiency)	4	20	21.0	420	1.05	.38	300
	5	30	18.0	540	.60	.21	300
	6	40	16.3	650	.41	.15	300

## Design

The QCW Series krypton arc lamps have been optimised for use as CW (DC) Nd:Yag laser pump lamps. They are of all quartz construction and are fabricated to withstand the high internal pressures and stresses associated with high power DC operation. In common with other lamps from PerkinElmer Optoelectronics the QCW Series uses the tungsten to silica or bright seal technique to form the hermetic seal between lamp body and electrode assembly. As all of the components used in QCW lamp construction have the ability to withstand high temperatures, extensive baking and degassing can be carried out to the finished lamps during pumping thus ensuring predictable and consistent results. Krypton arc lamp anodes are normally made from centreless ground tungsten rod, with some form of impregnated dispenser technique being used for the cathode. To maximise heat transfer and minimise the thermal gradient in the lamp envelope, krypton arc lamps are manufactured using tubing with a 0.5 mm wall thickness for the arc section. For strength and ease of manufacture, tubing with a 1.0 mm wall thickness is used at the lamp ends. During manufacture a portion of the silica envelope is shrunk onto the electrode assemblies for efficient heat transfer from the anode and cathode during operation. The quality of tubing used in high pressure lamps is very important and must be carefully inspected for defects, these include air lines, scratches, digs, etc. which weaken the lamp and render it susceptible to rupture during operation. For the same reason finished lamps must be carefully handled and should never come into contact with other lamps, or be placed on unprotected work surfaces as scratches can very easily occur.

## Cooling

QCW lamps are normally operated in a flow tube with a typical annulus of 1-2 mm. The coolant is normally deionised water at a flow rate of 6-10 litres per minute at a temperature of 20-35°C. Only stainless steel or plastic materials should come into contact with the coolant. A mixed bed resin deioniser should be used to maintain coolant conductivity to 100K ohms or better. The flow tube is normally made from quartz or pyrex, the latter giving useful UV filtering. The lamp electrical connectors (bases) are generally in contact with the coolant, although in some applications connections can be made outside the cavity using either bases or flexible leads.

## Installation

Safety glasses should be worn at all times when handling high pressure krypton arc lamps. Extreme care must be taken when changing lamps. Old lamps still at pressure can be safely disposed of by placing the lamp in a padded envelope and physically breaking the lamp whilst the package is sealed. The broken lamp, still in the envelope, can then be disposed of in the way that one would dispose of a broken light bulb. When pressing a lamp into connector clips, gentle and even pressure is the order of the day – never force the lamp. It should be noted that although the seal is strong in compression and tension it is very weak in the lateral plane.

## Operation

Krypton arc lamps are normally operated from constant current power supplies, the designs of which are either based around SCR or switched mode control principles. Typical lamp operating currents are from 20 amps (4 mm bore) to 50 amps (7 mm bore) with typical arc voltages of 100-180 volts. Lamp voltage is dependent on lamp operating current, lamp bore, arc length, gas pressure and lamp dead volume. The constant current supply needs additional circuitry to provide the high voltage 'trigger' and 'boost' required to start the lamp. At start up, a voltage of 20-25 kV is momentarily applied to the lamp via a step up transformer connected in the lamp circuit. This ionises the gas within the lamp which now becomes a conducting plasma. However, the lamp voltage is not low enough after triggering to allow current to flow from the constant current generator, the typical open circuit voltage of which is 200 volts. The 'boost' supply provides the bridge between the high impedance filamentary discharge created by the initial ionisation and the low impedance operating condition. In the 'boost' phase a small capacitor (say 47 mf charged to 1000 volts) is discharged through the lamp. The filamentary discharge created by the trigger pulse now grows in both arc diameter and current, and lamp voltage drops to a point where the constant current supply is able to take over and control the lamp.

## Fill Pressure

Krypton arc lamps are positive pressure devices. Pressures commonly specified are between 2 and 6 atmospheres. The fill pressure is generally dictated by the required operating voltage for a given lamp design. At fill pressures much above 6 atmospheres (4 mm bore lamp) lamp reliability is questionable. 6 mm bore lamps have a practical upper limit of 4 atmospheres. Lamps are filled on a precision positive pressure system. The average lamp to lamp variation can be held to better than + 5 volts. Lamp dead volume (the area behind the electrode tip) also plays a part in finalising the fill pressure. Although a lamp is manufactured with a given fill pressure, in operation this will rise. Lamps with large dead volumes will obtain lower pressures (and operating voltage) during operation than those with small dead volume. Up to a point this can be compensated for by increasing the cold fill pressure. Conversely there is a limit to how small dead volumes can be made as this also includes the length of electrode and hence the amount of area available for shrink down. Generally it is desirable to minimise dead volume where possible.

## Options

Examples shown are typical only of the QCW Series. Listed devices have clear fused quartz envelopes. For certain applications lamps are available with UV filtering (cerium doped) quartz. Other options include alternative bore sizes, arc and overall length, base sizes, flexible leads (4 and 5 mm bore lamps), gas fill and pressure. Lamps in the QCW Series can be supplied as equivalents for the majority of available krypton arc lamps.

## QDX SERIES

### Fast Rise Time, High Peak Power, Low Average Power, Xenon Filled Flashlamps

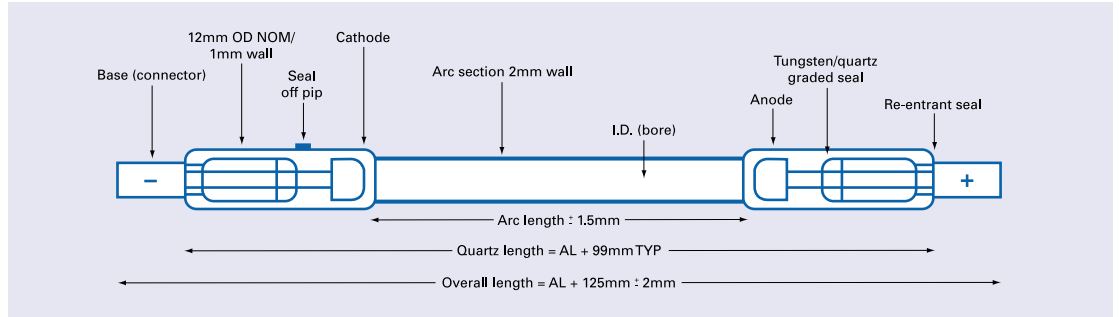

Bore Diameter (mm)	Arc Length (mm)	Overall Length (mm)	Base Size Dia/Length (mm)	Impedance Parameter $K_o$ Ohms-Amps <sup>0.5</sup>	Explosion Energy Const. $K_{E0.5}$ Watts (sec) <sup>0.5</sup>	Maximum Average Power – Watts		Operating Volts		Minimum Trigger Pulse kV	Minimum Trigger Pulse msec
						Convection	Forced Air	V min	V max		
3	50	175	7.14/13	18.1	$7.38 \times 10^4$	71	142	400	1400	18	0.4
3	75	200	7.14/13	27.2	$1.10 \times 10^5$	106	212	500	1750	18	0.6
3	100	225	7.14/13	36.3	$1.47 \times 10^5$	141	282	600	2100	18	0.8
3	150	275	7.14/13	54.4	$2.21 \times 10^5$	212	424	800	2800	18	1.2
4	50	175	7.14/13	13.6	$9.84 \times 10^4$	94	188	400	1400	18	0.4
4	75	200	7.14/13	20.4	$1.47 \times 10^5$	141	282	500	1750	18	0.6
4	100	225	7.14/13	27.2	$1.96 \times 10^5$	189	378	600	2100	18	0.8
4	150	275	7.14/13	40.8	$2.95 \times 10^5$	283	566	800	2800	18	1.2
4	200	325	7.14/13	54.4	$3.93 \times 10^5$	377	754	1000	3500	18	1.6
5	75	200	7.14/13	16.3	$1.84 \times 10^5$	177	354	500	1750	18	0.6
5	100	225	7.14/13	21.8	$2.46 \times 10^5$	236	472	600	2100	18	0.8
5	150	275	7.14/13	32.7	$3.69 \times 10^5$	353	706	800	2800	18	1.2
5	200	325	7.14/13	43.5	$4.92 \times 10^5$	471	942	1000	3500	18	1.6
5	300	425	7.14/13	65.3	$7.38 \times 10^5$	707	1414	1400	4900	18	2.4
6	75	200	7.14/13	13.6	$2.21 \times 10^5$	212	424	500	1750	18	0.6
6	100	225	7.14/13	18.1	$2.95 \times 10^5$	283	566	600	2100	18	0.8
6	150	275	7.14/13	27.2	$4.42 \times 10^5$	424	848	800	2800	18	1.2
6	200	325	7.14/13	36.3	$5.90 \times 10^5$	566	1132	1000	3500	18	1.6
6	300	425	7.14/13	54.4	$8.85 \times 10^5$	848	1696	1400	4900	18	2.4
7	75	200	7.14/13	11.7	$2.58 \times 10^5$	247	494	500	1750	18	0.6
7	100	225	7.14/13	15.5	$3.44 \times 10^5$	330	660	600	2100	18	0.8
7	150	275	7.14/13	23.3	$5.16 \times 10^5$	495	990	800	2800	18	1.2
7	200	325	7.14/13	31.1	$6.88 \times 10^5$	660	1320	1000	3500	18	1.6
7	300	425	7.14/13	46.6	$1.03 \times 10^6$	990	1980	1400	4900	18	2.4
8	100	225	7.14/13	13.6	$3.93 \times 10^5$	377	754	600	2100	20	0.8
8	150	275	7.14/13	20.4	$5.90 \times 10^5$	566	1132	800	2800	20	1.2
8	200	325	7.14/13	27.2	$7.87 \times 10^5$	754	1508	1000	3500	20	1.6
8	300	425	7.14/13	40.8	$1.18 \times 10^6$	1131	2262	1400	4900	20	2.4
8	450	575	7.14/13	61.2	$1.77 \times 10^6$	1697	3394	2000	7000	20	3.6

#### Options

Examples shown are typical only of the QDX range. Listed devices have clear fused quartz envelopes. Lamps with synthetic and UV filtering (cerium and titanium doped) quartz are available to order. Other options include alternative bore sizes, arc and overall lengths, base sizes, flexible leads, gas fill and pressure. The QDX Series can also be supplied with high voltage insulation end assemblies using flexible silicone covered cable.

#### Operation Data

QDX Series lamps are normally for use at pulse durations below 30 ms and at high energies. At longer pulse durations and lower peak powers higher efficiencies are obtained using the QXA Series lamps. At high energy and short pulse durations the QDX Series are normally operating above Vmax. A spark gap, hydrogen thyatron or ignitron being used to control lamp switching. For longest life simmer or prepulse operation should be used.

## QDF SERIES

### Fast Rise Time, High Peak Power, High Average Power, Liquid Cooled Xenon Flashlamps

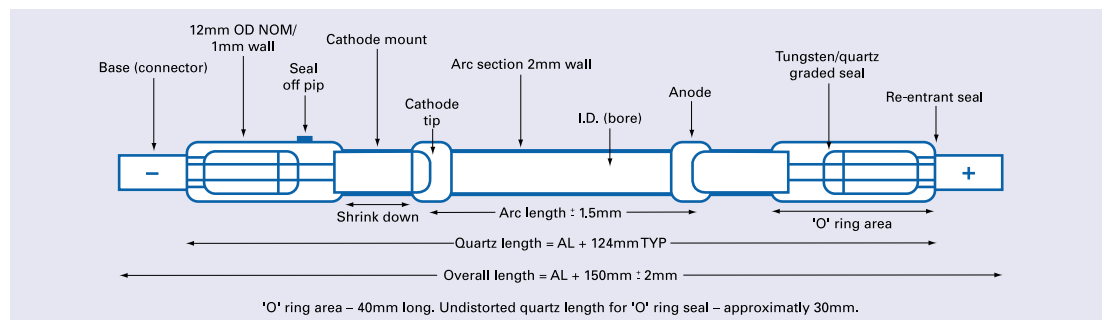

Bore Diameter (mm)	Arc Length (mm)	Overall Length (mm)	Base Size Dia/Length (mm)	Impedance Parameter $K_o$ Ohms-Amps <sup>0.5</sup>	Explosion Energy Const. $K_e$ Watts (sec) <sup>0.5</sup>	Maximum Average Power Watts	Operating Volts		Minimum Trigger Pulse kV	msec
							V min	V max		
3	50	200	7.14/13	18.1	$7.38 \times 10^4$	471	400	1400	18	0.4
3	75	225	7.14/13	27.2	$1.10 \times 10^5$	707	500	1750	18	0.6
3	100	250	7.14/13	36.3	$1.47 \times 10^5$	943	600	2100	18	0.8
3	150	300	7.14/13	54.4	$2.21 \times 10^5$	1414	800	2800	18	1.2
4	50	200	7.14/13	13.6	$9.84 \times 10^4$	628	400	1400	18	0.4
4	75	225	7.14/13	20.4	$1.47 \times 10^5$	943	500	1750	18	0.6
4	100	250	7.14/13	27.2	$1.96 \times 10^5$	1257	600	2100	18	0.8
4	150	300	7.14/13	40.8	$2.95 \times 10^5$	1885	800	2800	18	1.2
4	200	350	7.14/13	54.4	$3.93 \times 10^5$	2514	1000	3500	18	1.6
5	75	225	7.14/13	16.3	$1.84 \times 10^5$	1178	500	1750	18	0.6
5	100	250	7.14/13	21.8	$2.46 \times 10^5$	1571	600	2100	18	0.8
5	150	300	7.14/13	32.7	$3.69 \times 10^5$	2357	800	2800	18	1.2
5	200	350	7.14/13	43.5	$4.92 \times 10^5$	3142	1000	3500	18	1.6
5	300	450	7.14/13	65.3	$7.38 \times 10^5$	4713	1400	4900	18	2.4
6	75	225	7.14/13	13.6	$2.21 \times 10^5$	1414	500	1750	18	0.6
6	100	250	7.14/13	18.1	$2.95 \times 10^5$	1885	600	2100	18	0.8
6	150	300	7.14/13	27.2	$4.42 \times 10^5$	2828	800	2800	18	1.2
6	200	350	7.14/13	36.3	$5.90 \times 10^5$	3770	1000	3500	18	1.6
6	300	450	7.14/13	54.4	$8.85 \times 10^5$	5656	1400	4900	18	2.4
7	75	225	7.14/13	11.7	$2.58 \times 10^5$	1650	500	1750	18	0.6
7	100	250	7.14/13	15.5	$3.44 \times 10^5$	2199	600	2100	18	0.8
7	150	300	7.14/13	23.3	$5.16 \times 10^5$	3299	800	2800	18	1.2
7	200	350	7.14/13	31.1	$6.88 \times 10^5$	4399	1000	3500	18	1.6
7	300	450	7.14/13	46.6	$1.03 \times 10^6$	6598	1400	4900	18	2.4
8	100	250	7.14/13	13.6	$3.93 \times 10^5$	2514	600	2100	20	0.8
8	150	300	7.14/13	20.4	$5.90 \times 10^5$	3770	800	2800	20	1.2
8	200	350	7.14/13	27.2	$7.87 \times 10^5$	5027	1000	3500	20	1.6
8	300	450	7.14/13	40.8	$1.18 \times 10^6$	7541	1400	4900	20	2.4
8	450	600	7.14/13	61.2	$1.77 \times 10^6$	11311	2000	7000	20	3.6

#### Operating and Cooling Data

QDF Series lamps are normally for use at pulse durations below 30ms and at high peak and average powers. At longer pulse durations and lower peak powers higher efficiencies are obtained using the QXF Series lamps. At high energy and short pulse durations the QDX Series is normally operating above  $V_{max}$ . A spark gap, hydrogen thyatron, or ignitron being used to control lamp switching. For longest life simmer or prepulse operation should be used. QDF series lamps must be operated in a flowing liquid cooling medium typically deionised water at approximate flow rates of 2-6 litres per minute. Liquid flow must be over arc area and shrink down region. Generally connectors will not be in contact with coolant. Only plastic or stainless steel should be used for

cooling system components. A deionising cartridge should be incorporated in the cooling system in order to keep the coolant resistivity low.

#### Options

Examples shown are typical only of the QDF range. Listed devices have clear fused quartz envelopes. Lamps with synthetic and UV filtering (cerium and titanium doped) quartz are available to order. Other options include alternative bore sizes, arc and overall lengths, base sizes, flexible leads, gas fill and pressure. The QDF series can also be supplied with high voltage insulation end assemblies using flexible silicone covered cable. The QDF series have been supplied with bore diameters of 10mm and arc lengths of 1 metre.

## QXA MINIATURE SERIES

### Miniature Air Cooled, Xenon Flashlamps for Low Average Power, Medium Peak Power Operation

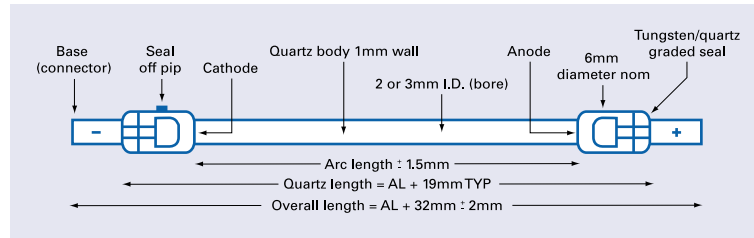

Bore Diameter (mm)	Arc Length (mm)	Overall Length (mm)	Base Size Dia/Length (mm)	Impedance Parameter $K_0$ Ohms-Amps <sup>0.5</sup>	Explosion Energy Const. $K_{0.5}$ Watts (sec) <sup>0.5</sup>	Maximum Average Power – Watts		Operating Volts		Minimum Trigger Pulse	
						Convection	Forced Air	V min	V max	kV	msec
2	15	47	4.76/6.5	9.6	$7.38 \times 10^3$	14	28	360	1260	16	0.12
2	20	52	4.76/6.5	12.8	$9.84 \times 10^3$	19	38	380	1330	16	0.16
2	25	57	4.76/6.5	16.0	$1.23 \times 10^4$	24	48	400	1400	16	0.20
2	40	72	4.76/6.5	25.6	$1.96 \times 10^4$	38	76	460	1610	16	0.32
2	50	82	4.76/6.5	32.0	$2.46 \times 10^4$	47	94	500	1750	16	0.40
3	15	47	4.76/6.5	6.4	$1.10 \times 10^4$	21	42	360	1260	16	0.12
3	20	52	4.76/6.5	8.5	$1.47 \times 10^4$	28	56	380	1330	16	0.16
3	25	57	4.76/6.5	10.7	$1.84 \times 10^4$	35	70	400	1400	16	0.20
3	40	72	4.76/6.5	17.1	$2.95 \times 10^4$	57	114	460	1610	16	0.32
3	50	82	4.76/6.5	21.3	$3.69 \times 10^4$	71	142	500	1750	16	0.40
3	75	107	4.76/6.5	32.0	$5.53 \times 10^4$	106	212	600	2100	16	0.60

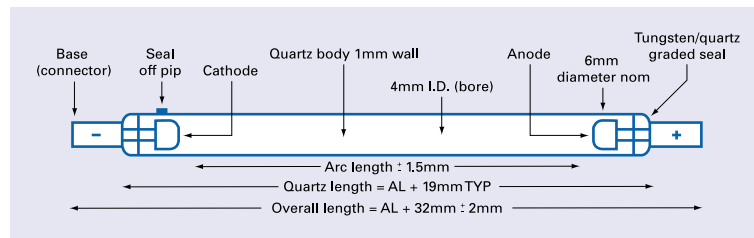

Bore Diameter (mm)	Arc Length (mm)	Overall Length (mm)	Base Size Dia/Length (mm)	Impedance Parameter $K_0$ Ohms-Amps <sup>0.5</sup>	Explosion Energy Const. $K_{0.5}$ Watts (sec) <sup>0.5</sup>	Maximum Average Power – Watts		Operating Volts		Minimum Trigger Pulse	
						Convection	Forced Air	V min	V max	kV	msec
4	15	47	4.76/6.5	4.8	$1.47 \times 10^4$	28	56	360	1260	16	0.12
4	20	52	4.76/6.5	6.4	$1.96 \times 10^4$	38	76	380	1330	16	0.16
4	25	57	4.76/6.5	8.0	$2.46 \times 10^4$	47	94	400	1400	16	0.20
4	40	72	4.76/6.5	12.8	$3.93 \times 10^4$	75	150	460	1610	16	0.32
4	50	82	4.76/6.5	16.0	$4.92 \times 10^4$	94	188	500	1750	16	0.40
4	75	107	4.76/6.5	24.0	$7.38 \times 10^4$	141	282	600	2100	16	0.60

#### Options

Examples shown are typical only of the QXA miniature range. Listed devices have clear fused quartz envelopes. Lamps with synthetic and UV filtering (cerium and titanium doped) quartz are available to order. Other options include alternative bore sizes, arc and overall lengths, base sizes, flexible leads, gas fill and pressure. QXA miniature series lamps can be supplied with special conditioning for low series trigger voltages. Precision bore tubing option on 2-3mm bore lamps.

## QXF MINIATURE SERIES

### Miniature Liquid Cooled, Xenon Flashlamps for High Average Power, Medium Peak Power Operation

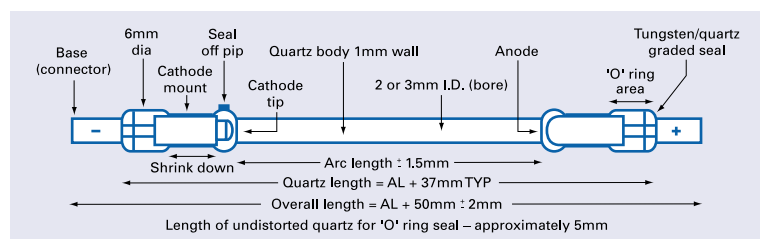

Bore Diameter (mm)	Arc Length (mm)	Overall Length (mm)	Base Size Dia/Length (mm)	Impedance Parameter $K_0$ Ohms-Amps <sup>0.5</sup>	Explosion Energy Const. $K_{e0.5}$ Watts (sec) <sup>0.5</sup>	Maximum Average Power (watts)	Maximum Average Power (amps)	Operating Volts		Minimum Trigger Pulse	
								V min	V max	kV	msec
2	15	65	4.76/6.5	9.6	$7.38 \times 10^3$	189	125	360	1260	16	0.12
2	20	70	4.76/6.5	12.8	$9.84 \times 10^3$	251	125	380	1330	16	0.16
2	25	75	4.76/6.5	16.0	$1.23 \times 10^4$	314	125	400	1400	16	0.20
2	40	90	4.76/6.5	25.6	$1.96 \times 10^4$	503	125	460	1610	16	0.32
2	50	100	4.76/6.5	32.0	$2.46 \times 10^4$	628	125	500	1750	16	0.40
3	15	65	4.76/6.5	6.4	$1.10 \times 10^4$	283	280	360	1260	16	0.12
3	20	70	4.76/6.5	8.5	$1.47 \times 10^4$	377	280	380	1330	16	0.16
3	25	75	4.76/6.5	10.7	$1.84 \times 10^4$	471	280	400	1400	16	0.20
3	40	90	4.76/6.5	17.1	$2.95 \times 10^4$	754	280	460	1610	16	0.32
3	50	100	4.76/6.5	21.3	$3.69 \times 10^4$	943	280	500	1750	16	0.40
3	75	125	4.76/6.5	32.0	$5.53 \times 10^4$	1414	280	600	2100	16	0.60

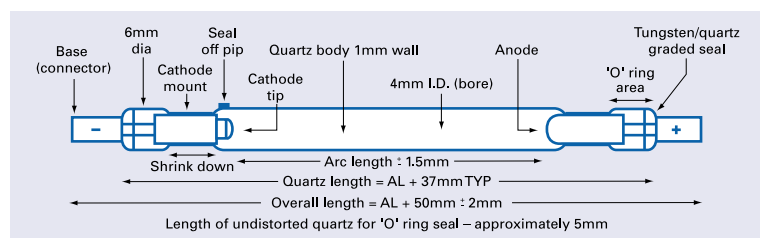

Bore Diameter (mm)	Arc Length (mm)	Overall Length (mm)	Base Size Dia/Length (mm)	Impedance Parameter $K_0$ Ohms-Amps <sup>0.5</sup>	Explosion Energy Const. $K_{e0.5}$ Watts (sec) <sup>0.5</sup>	Maximum Average Power (watts)	Maximum Average Power (amps)	Operating Volts		Minimum Trigger Pulse	
								V min	V max	kV	msec
4	15	65	4.76/6.5	4.8	$1.47 \times 10^4$	377	500	360	1260	16	0.12
4	20	70	4.76/6.5	6.4	$1.96 \times 10^4$	503	500	380	1330	16	0.16
4	25	75	4.76/6.5	8.0	$2.46 \times 10^4$	628	500	400	1400	16	0.2
4	40	90	4.76/6.5	12.8	$3.93 \times 10^4$	1005	500	460	1610	16	0.32
4	50	100	4.76/6.5	16.0	$4.92 \times 10^4$	1257	500	500	1750	16	0.4
4	75	125	4.76/6.5	24.0	$7.38 \times 10^4$	1885	500	600	2100	16	0.6

#### Options

Examples shown are typical only of the QXF miniature range. Listed devices have clear fused quartz envelopes. Lamps with synthetic and UV filtering (cerium and titanium doped) quartz are available to order. Other options include alternative bore sizes, arc and overall lengths, base sizes, flexible leads, gas fill and pressure. QXF miniature series lamps are suitable for simmer operation and can be supplied with special conditioning for low series trigger voltages. Precision bore tubing option on 2-3mm bore lamps.

#### Cooling Requirements

QXF miniature series lamps must be operated in a flowing liquid cooling medium, typically deionised water at approximately 1-4 litres per minute. Liquid flow must be over arc area and shrink down region. Generally connectors will not be in contact with coolant. Only plastic or stainless steel should be used for cooling system components. A deionising cartridge may be required in the cooling system in order to keep the coolant resistivity low.



## QJK SERIES

### Liquid Cooled, Krypton Filled Flashlamps for High Average Power, Low Peak Power Operation at Pulse Durations in the Millisecond Regime

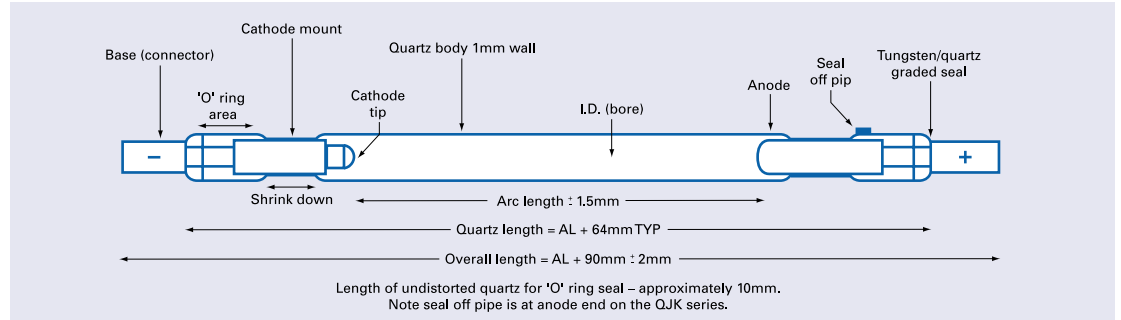

Bore Diameter (mm)	Arc Length (mm)	Overall Length (mm)	Base Size Dia/Length (mm)	Impedance Parameter $K_0$ Ohms-Amps <sup>0.5</sup>	Explosion Energy Const. $K_0^{0.5}$ Watts (sec) <sup>0.5</sup>	Maximum Average Power (watts)	Maximum Average Power (amps)	Operating Volts V min	Operating Volts V max	Minimum Trigger kV	Pulse msec
4	50	140	4.75/13	15.6	$4.92 \times 10^4$	1257	500	500	1750	16	0.4
4	75	165	4.75/13	23.3	$7.38 \times 10^4$	1885	500	600	2100	16	0.6
4	100	190	4.75/13	31.1	$9.84 \times 10^4$	2514	500	700	2450	16	0.8
4	125	215	4.75/13	38.9	$1.23 \times 10^5$	3142	500	800	2800	16	1.0
5	50	140	4.75/13	12.4	$6.15 \times 10^4$	1571	800	500	1750	16	0.4
5	75	165	4.75/13	18.7	$9.22 \times 10^4$	2357	800	600	2100	16	0.6
5	100	190	4.75/13	24.9	$1.23 \times 10^5$	3142	800	700	2450	16	0.8
5	125	215	4.75/13	31.1	$1.53 \times 10^5$	3928	800	800	2800	16	1.0
5	150	240	4.75/13	37.3	$1.84 \times 10^5$	4713	800	900	3150	16	1.2
6	75	165	7.14/13	15.6	$1.10 \times 10^5$	2828	1100	600	2100	16	0.6
6	100	190	7.14/13	20.7	$1.47 \times 10^5$	3770	1100	700	2450	16	0.8
6	125	215	7.14/13	25.9	$1.84 \times 10^5$	4713	1100	800	2800	16	1.0
6	150	240	7.14/13	31.1	$2.21 \times 10^5$	5656	1100	900	3150	16	1.2
6	200	290	7.14/13	41.5	$2.95 \times 10^5$	7541	1100	1100	3850	16	1.6
7	75	165	7.14/13	13.3	$1.29 \times 10^5$	3299	1400	600	2100	18	0.6
7	100	190	7.14/13	17.8	$1.72 \times 10^5$	4399	1400	700	2450	18	0.8
7	125	215	7.14/13	22.2	$2.15 \times 10^5$	5499	1400	800	2800	18	1.0
7	150	240	7.14/13	26.7	$2.58 \times 10^5$	6598	1400	900	3150	18	1.2
7	200	290	7.14/13	35.6	$3.44 \times 10^5$	8798	1400	1100	3850	18	1.6
8	100	190	7.14/13	15.6	$1.96 \times 10^5$	5027	1800	700	2450	18	0.8
8	125	215	7.14/13	19.4	$2.46 \times 10^5$	6284	1800	800	2800	18	1.0
8	150	240	7.14/13	23.3	$2.95 \times 10^5$	7541	1800	900	3150	18	1.2
8	200	290	7.14/13	31.1	$3.93 \times 10^5$	10054	1800	1100	3850	18	1.6
8	250	340	7.14/13	38.9	$4.92 \times 10^5$	12568	1800	1300	4550	18	2.0
10	100	190	7.14/13	12.4	$2.10 \times 10^5$	6284	2800	700	2450	20	0.8
10	150	240	7.14/13	18.7	$3.15 \times 10^5$	9426	2800	900	3150	20	1.2
10	200	290	7.14/13	24.9	$4.20 \times 10^5$	12568	2800	1100	3850	20	1.6
10	250	340	7.14/13	31.1	$5.25 \times 10^5$	15710	2800	1300	4550	20	2.0
10	300	390	7.14/13	37.3	$6.30 \times 10^5$	18852	2800	1500	5250	20	2.4

#### Options

Examples shown are typical only of the QJK range. Listed devices have clear fused quartz envelopes. Lamps with synthetic and UV filtering (cerium and titanium doped) quartz are available to order. Other options include alternative bore sizes, arc and overall lengths, base sizes, flexible leads, gas fill and pressure. QJK Series lamps are also available with 0.5mm thickness quartz.

#### Operating and Cooling Data

QJK Series lamps must be operated in a flowing liquid cooling medium typically deionised water at approximate flow-rates

of 48 litres per minute. Liquid flow must be over arc area and shrink down region. Generally connectors will not be in contact with coolant. Stainless steel connectors available for totally immersed lamps. Only plastic or stainless steel should be used for cooling system components. A deionising cartridge should be incorporated in the cooling system in order to keep the coolant resistivity low. QJK Series lamps are normally operated under simmer conditions with pulse duration controlled electronically. They can also be used with multiple L.C. pulse forming networks.

## QXA RING SERIES

### Air Cooled, Ring Format, Xenon Flashlamps for Low Average Power, Medium Peak Power Operation

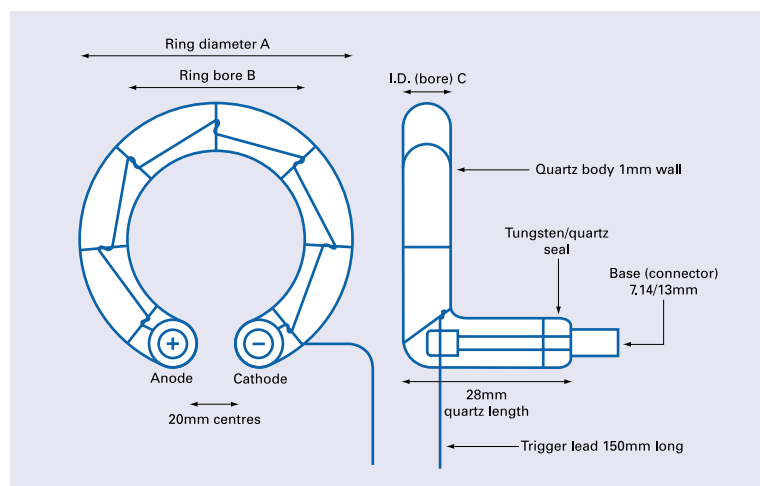

Ring diameter (A mm)	32	52	46	66	55	75
Ring bore (B mm)	20	40	30	50	53	55
Envelope bore (C mm)	4	4	6	6	8	8
$K_o$ Ohms (amps) <sup>0.5</sup>	17.5	35.4	18.8	30.7	17.2	26.2
$K_b$ Watts(sec) <sup>0.5</sup>	$6.0 \times 10^4$	$1.2 \times 10^5$	$1.4 \times 10^5$	$2.3 \times 10^5$	$2.3 \times 10^5$	$3.6 \times 10^5$
Max average power (watts)	116	234	280	458	457	694
Operating volts (Vmin)	385	573	498	686	564	752
Operating volts (Vmax)	1347	2007	1743	2403	1974	2634
Min trigger volts(kV)	12	14	16	16	16	16

#### Options

Examples shown are typical only of the QXA Ring Series. Listed devices have clear fused quartz envelopes. Lamps with synthetic and UV filtering (cerium and titanium doped) quartz are available to order. Other options include alternative tubing sizes, ring diameters, electrode configurations, base sizes, flexible leads, gas fill and pressure.

#### Operation

QXA Ring Series were originally developed for photographic applications but will find many uses where a compact high energy pulsed light source is required. They are typically operated from electrolytic capacitors with overdamped current pulses in the millisecond range. Also suitable for operation at shorter pulse durations. Average power can be doubled with forced air cooling. Lower operational voltages available.

## QXA 12 AND QXA 33 SOURCE LAMP

### Air Cooled, High Intensity, High Stability Xenon Flashlamp for Instrumentation and Laboratory Use

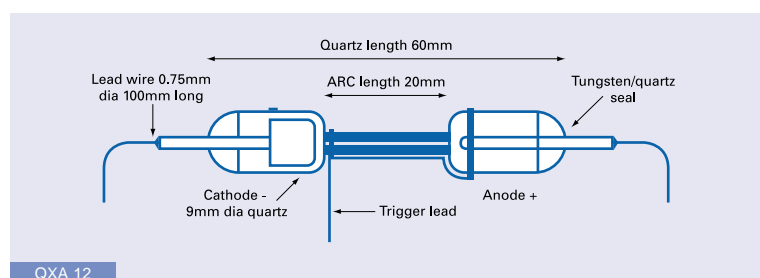

QXA 12

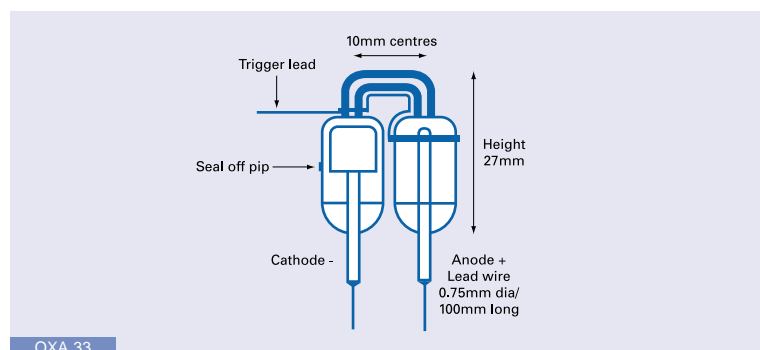

QXA 33

#### Data QXA 12 and QXA 33

Bore	0.5(mm)
Vmin	350 (volts)
Vmax	1000 (volts)
Trigger	10 (kV)
$K_o$	48 ohms (amps) <sup>0.5</sup>
$K_b$	$2.46 \times 10^3$ watts (sec) <sup>0.5</sup>
Max average power	20 (watts)
Cooling	Convection
Typical operating conditions:	
pulse duration	10 msecs
storage capacitor	1 mf
operating volts	560 (volts)
pulse rate	50 (Hz)
life time	500 hours
Spectral distribution	220-1200nm
Operating position	Any

#### Options

Listed devices have clear fused quartz envelopes. Lamps with synthetic quartz are available to order. Other options include alternative arc lengths, electrode configurations, base sizes, flexible leads, gas fill and pressure. QXA33 has identical electrical parameters to those of the QXA12.

**QCA SERIES**

**Air Cooled, Compact Arc, Xenon Flashlamps for Pulsed and C/W (DC) Operation**

**QCA 96 compact arc lamp for pulsed operation**

Typical applications include: Stroboscopes, High speed photography.

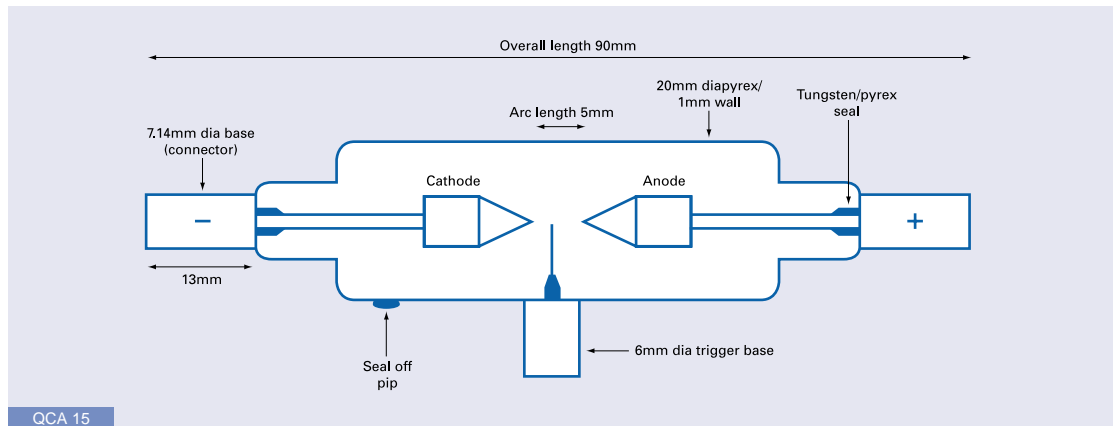
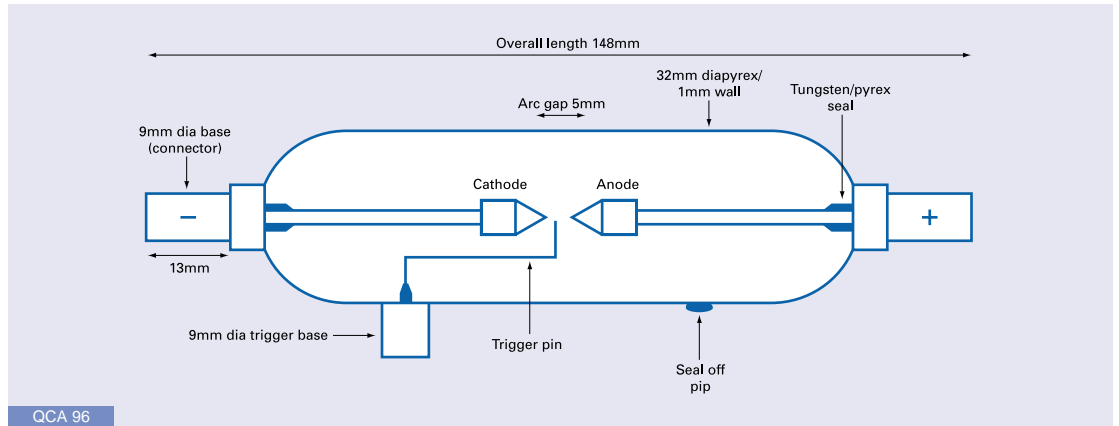

**Data QCA 96**

Arc length	5 (mm)
Minimum operating volts (Vmin)	
(using trigger electrode)	900 (volts)
(using series triggering)	100 (volts)
Mm trigger volts	
(using trigger electrode)	10 (kV)
(using series trigger)	16 (kV)
Maximum average power	250 (watts)
$K_o$ [ohms (amps) <sup>0.65</sup> ] (approx.)	1.5
Maximum operating volts (Vmax)	2500 (volts)
Maximum base temperature	150°C
Maximum energy	250 (joules)
Operating position	Any
Cooling	Convection
Envelope material	Pyrex

**Data QCA 15**

Arc length	5 (mm)
Minimum operating volts (Vmin)	
(using trigger electrode)	900 (volts)
(using series triggering)	100 (volts)
Mm trigger volts	
(using trigger electrode)	10 (kV)
(using series trigger)	16 (kV)
Maximum average power	100 (watts)
$K_o$ [ohms (amps) <sup>0.65</sup> ] (approx.)	1.5
Maximum operating volts (Vmax)	2500 (volts)
Maximum base temperature	150t
Maximum energy	150 (joules)
Operating position	Any
Cooling	Convection
Envelope material	Pyrex

The QCA5 and QCA15 have a trigger electrode located at the arc gap. This makes possible the use of low cost trigger configurations compared to series triggering. As there is no significant inductance compared to series triggering, short pulse durations can be achieved i.e. 20ms using 40 mf at 2500 volts = 125 joules.

## QCA 20-24 high performance quartz compact arc lamps for pulsed operation using series trigger

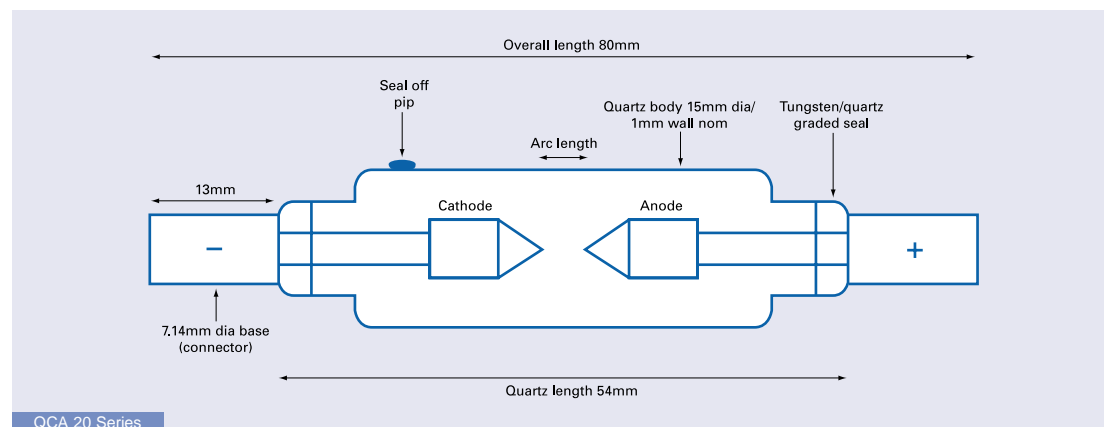

Applications include: Stroboscopes, Photochemical reaction studies, Effects projectors and other situations requiring point source high intensity flash illumination. The use of series triggering coupled with the low  $K_0$  value for the QCA Series lamps, makes it difficult to design for critical damping using conventional procedures.

Generally the circuit will be under damped and oscillatory, with values of  $\alpha$  as low as 0.1 not uncommon. The effective solution uses a shunt diode across the storage capacitor (Figure Q) so that energy stored in the inductor (trigger transformer) is transferred through the lamp rather than back to the capacitor as a negative voltage.

Lamp Model No.	QCA20	QCA21	QCA22	QCA23	QCA24
Arc length (mm)	1.5	3.0	5.0	7.0	10.0
Maximum average power (watts)	150	150	150	150	180
Maximum energy (joules)	60	80	100	100	120
Maximum voltage ( $V_{max}$ ) (volts)	1000	1500	2000	2500	2500
Minimum voltage ( $V_{min}$ ) (volts)	50	75	100	120	150
Minimum trigger voltage (kV)	10	12	14	16	18
$K_0$ [ohms (amps) <sup>0.5</sup> ] (approx.)	0.4	0.7	1.2	1.7	2.2
Cooling	CONVECTION				
Operating position	ANY POSITION				

### Options

Listed (quartz) devices have clear fused quartz envelopes. Lamps with synthetic and UV filtering (cerium and titanium) doped quartz are available to order. Other options (all lamps) include alternative arc lengths, base sizes, flexible leads, gas fill and pressure.

### Operating Data

Compact arc lamp life times are not accurately predicted by calculation. Lifetime estimates are therefore based upon known case histories and in situ testing. Under pulsed conditions (18 joules/8.5Hz/1ms) lamp type QCA23 has routinely achieved life-times in excess of 12 million pulses.

All QCA Series lamps have a low impedance characteristic, to maximise energy transfer circuit impedance should be as low as possible.

## QCA SERIES

Point Source High Stability, High Pressure, Xenon Lamps for DC Operation QCA 32 and QCA 33 are for Operation in the Power Range 10-40 Watts

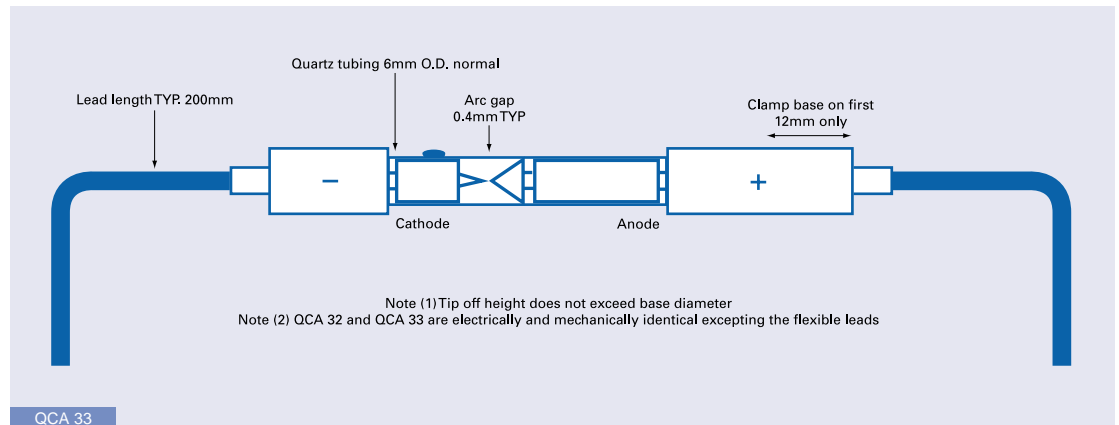
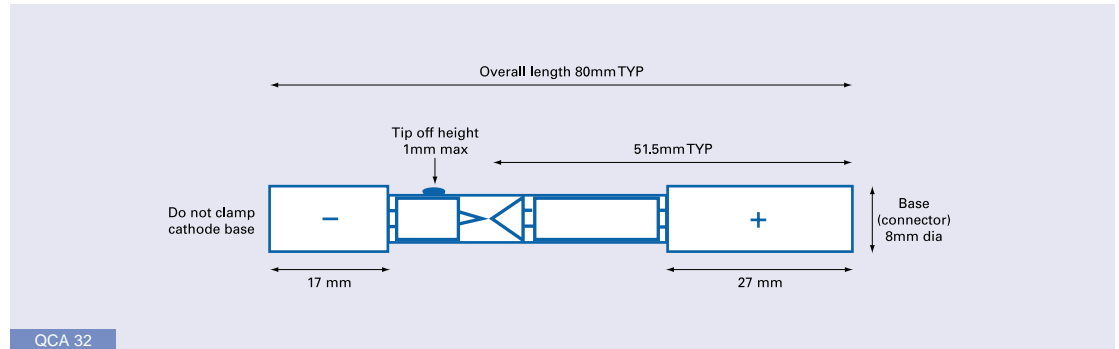

### Special Features Include

- High stability cathode.
- Parallel tubing over arc area for virtually distortion free light transmission.
- Low simmer current.
- Low energy series trigger.
- Requires low open circuit voltage.
- Compact size.
- Horizontal or vertical operation.
- Wide operating levels (10-40 watts).
- Customisation possible.
- Krypton fill available

### Data QCA 32 and QCA 33

Operating voltage	10-14 (volts)
Operating current	1-4 (amps)
Minimum supply voltage	30 (volts)
Maximum rated power	40 (watts)
Minimum rated power	10 (watts)
Minimum trigger voltage	15 (kV)
Typical trigger energy	36 (mJ)
Typical minimum simmer current	150/200 (ma)
Typical arc gap	0.35 (mm)
Typical life	1000 (hours)
Cooling	Convection
Maximum base temperature	250°C
Spectral distribution	185-1200 nm
Ozone or non ozone envelope	
Horizontal or vertical operation	

### Options

The QCA 32 and 33 are supplied as standard with clear fused quartz envelopes. Lamps with synthetic quartz for improved UV output are available to order. Also available are lamps with UV absorbing quartz (cerium and titanium doped). Other options include arc gap length, higher power lamps, overall length, base sizes, gas type.

### Operation

For high stability operation the QCA 32 and 33 should be operated from electronically stabilised constant current power supplies using series regulation. The power supply should be of a high stability design as lamp output intensity can vary by approximately 0.25%/ 10 ma. They can be operated from 'reactance' stabilised LC smoothed supplies but stabilisation and lamp life will not be very good.

### Cooling

The QCA 32 and 33 lamps are designed for convection cooling. 10-20 minutes will be required for the output to stabilise due to increase in gas pressure after the lamp is ignited. Anode heat sinking should be kept to a minimum as this affects the times taken for the lamp to stabilise. Generally air flow across the lamp should be avoided as this will affect stability.

## QHX SERIES

### Air Cooled, Xenon Filled Helical Flashlamps

#### Tangential

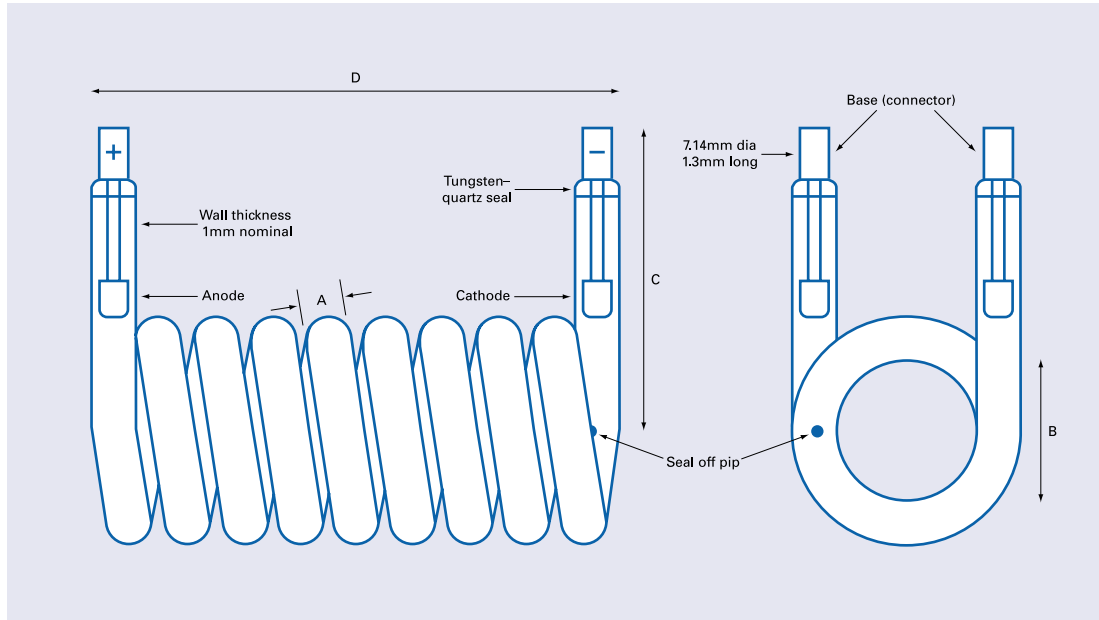

Envelope Bore Diameter A (mm)	No. of Turns	Helix Bore B (mm)	Limb Length C (mm)	Overall Length D (mm)	Impedance Parameter $K_0$ Ohms-Amps <sup>0.5</sup>	Explosion Energy Const. $K_{0.5}$ Watts (sec) <sup>0.5</sup>	Maximum Power – Watts Convection	Average Power – Watts Forced Air	Operating Volts V min	V max	Minimum Trigger kV	Pulse msec
4	1.5	10	50	18	24.0	$3.70 \times 10^4$	142	284	601	2105	16	0.2
4	6.5	20	55	63	169.0	$2.60 \times 10^5$	1000	2000	2423	8483	16	2.0
5	3.5	15	55	21	62.0	$1.48 \times 10^5$	569	1139	1267	4436	16	1.0
5	6.5	20	55	70	141.0	$3.39 \times 10^5$	1299	2598	2505	8768	16	2.2
6	3.5	20	60	44	65.6	$2.27 \times 10^5$	870	1740	1531	5360	16	1.2
6	8.5	25	60	100	187.0	$6.50 \times 10^5$	2491	4983	3824	13387	16	3.4
8	6.5	20	60	91	114.0	$7.03 \times 10^5$	2694	5388	3158	11055	18	2.8
8	8.5	25	65	117	149.0	$9.19 \times 10^5$	3523	7046	4038	14134	20	3.8
10	4.5	25	65	75	67.0	$5.49 \times 10^5$	2464	4929	2392	8373	25	2.0
10	8.5	35	70	135	160.0	$1.31 \times 10^6$	5914	11828	5320	18620	25	4.0
13	6.5	40	75	150	110.0	$1.46 \times 10^6$	6880	13760	4792	16773	25	4.4
13	12.5	50	80	234	251.0	$3.31 \times 10^6$	15637	31274	10510	36785	30	10.2

#### Options

Examples shown are typical only of QHX range. Listed devices have clear fused quartz envelopes. Lamps with synthetic and UV filtering (cerium and titanium doped) quartz are available to order. Other options include alternative helix and tubing sizes, flexible leads, base sizes, gas fill and pressure.

## QHX SERIES

### Air Cooled, Xenon Filled Helical Flashlamps

#### Perpendicular

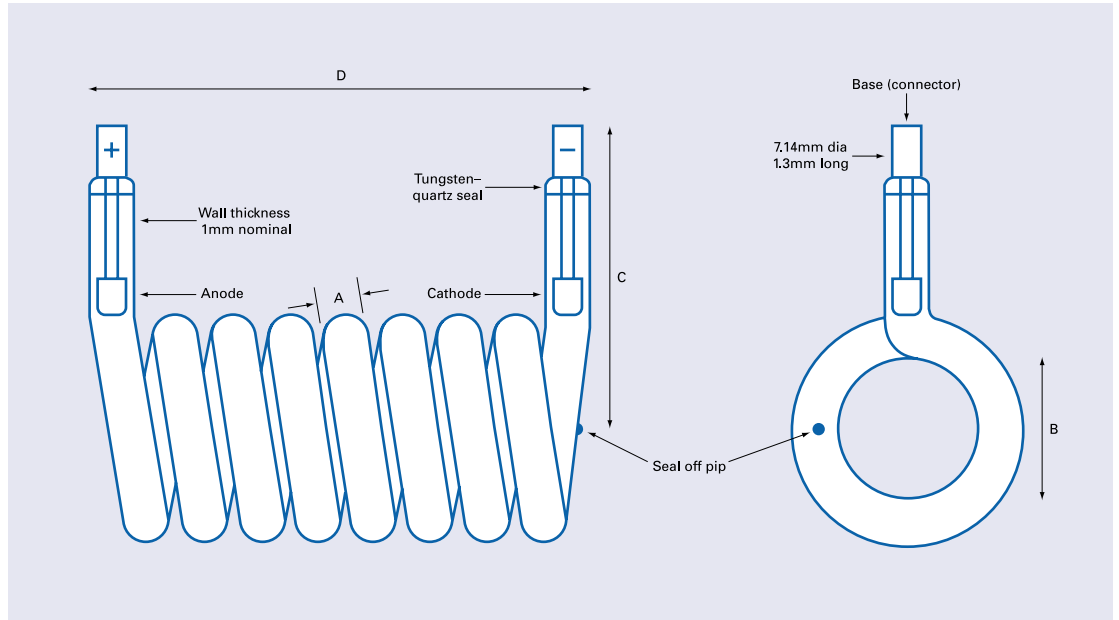

Envelope Bore Diameter A (mm)	No. of Turns	Helix Bore B (mm)	Limb Length C (mm)	Overall Length D (mm)	Impedance Parameter $K_0$ Ohms-Amps <sup>0.5</sup>	Explosion Energy Const. $K_{0.5}$ Watts (sec) <sup>0.5</sup>	Maximum Power – Watts Convection	Average Power – Watts Forced Air	Operating Volts V min	V max	Minimum Trigger kV	Pulse msec
4	3	10	50	27	48	$7.41 \times 10^4$	284	568	903	3161	16	0.6
4	8	20	55	72	209	$3.21 \times 10^5$	1231	2463	2913	10198	16	2.6
5	3	15	55	30	149	$3.59 \times 10^5$	1376	2753	2637	9230	16	2.4
5	9	20	55	90	195	$4.69 \times 10^5$	1798	3597	3353	11737	16	3.0
6	3	20	60	33	56	$1.94 \times 10^5$	746	1492	1355	4744	16	1.0
6	10	25	60	110	221	$7.65 \times 10^5$	2931	5862	4446	15564	16	4.0
8	3	20	60	39	45	$2.78 \times 10^5$	1065	2131	1430	5008	18	1.2
8	10	25	65	130	175	$1.08 \times 10^6$	4145	8290	4698	16443	20	4.4
10	3	25	65	45	44	$3.86 \times 10^5$	1643	3286	1694	5932	25	1.4
10	10	35	70	150	188	$1.55 \times 10^6$	6958	13916	6206	21721	25	6.0
13	4	40	75	72	68	$8.98 \times 10^6$	4234	8468	3064	10726	25	2.8
13	14	50	80	252	281	$3.71 \times 10^6$	17513	35027	11735	41073	30	11.4

#### Options

Examples shown are typical only of QHX range. Listed devices have clear fused quartz envelopes. Lamps with synthetic and UV filtering (cerium and titanium doped) quartz are available to order. Other options include alternative helix and tubing sizes, flexible leads, base sizes, gas fill and pressure.



# PerkinElmer Optoelectronics Global Operations

