

The Instructions of WT588D-U Voice Module

www.elechouse.com

1、 Product Features	1
2、 Functional Description	
3、 Application scopes	4
4、 Application Block diagram	4
5、 Pin Package Fig.	5
6、 Electrical Parameters.....	6
7、 The Absolute Limits of The Environment Parameters.....	7
8、 Control Mode	7
8.1、 Button Control Mode	7
8.1.1、 Tigger Impulse Repetition	7
8.1.2、 Trigger Impluse Without Repetition	8
8.1.3、 Recycled Level.....	8
8.1.4、 Nocycle Level	8
8.1.5、 Non-Maintained Cycle Level.....	9
8.1.6、 Play / Stop	9
8.1.7、 Non-Cycle for The Next Tone.....	9
8.1.8、 Non-Cycle for The Last Tone	10
8.1.9、 Recycle for The Next Tone	10
8.1.10、 Recycle for The Last Tone.....	10
8.1.11、 Pause	11
8.1.12、 Stop.....	11
8.2、 One-Wire Serial Port Control Mode	11
8.2.1、 Port Allocation Table.....	11
8.2.2、 Order and Speech Cording.....	12
8.2.3、 Voice Address Correspondence	12
8.2.4、 Control Time Sequence Chart.....	12
8.2.5、 The Example of 1-Wire Serial Port Control Time Sequence	13
8.2.6、 Models of Procedure.....	13
8.3、 Three-Wire Serial Control mode	14
8.3.1、 Port Allocation Methods	14
8.3.2、 Voice and Command Code Corresponding to Table	14
8.3.3、 Voice Address Corresponds	14
8.3.4、 Three-Wire Serial Port Control Time Sequence.....	15
8.3.5、 Modles of Procedure.....	15
9、 Typical Application Circuit	16
9.1、 Typical Application Circuit of Key to Control (PWM output, 5V Supply)	16
9.2、 Typical Application Circuit of Keys to Control (PWM output, 3.3V Supply)	16
9.3、 Typical Application Circuit of Keys to Control (DAC output)	17
9.4、 Typical Application of Frst-line Serial Cntrol Circuit (PWM Output)	17
9.5、 Typical Application of First-line Serial Control Circuit (DAC Output)	17
9.6、 One-Wire Serial Port MCU5V Power/ Module 3.3V Power Supply Application circuit (PWM output)	18

9.7、 Three-Wire Serial Control of Typical Application circuit (PWM output)	19
9.8、 Three-wire serial control of a typical application circuit (DACoutput)	19
9.9、 Three-wire serial MCU5V power / module 3.3V power supply application circuit (PWM output) MCU5V	19
10、 Control procedures	20
10.1、 One-wire serial control of assembler	20
10.2、 One-wire serial control of C-voice procedures	21
10.3、 Three-wire serial control of assembler	23
10.4、 Three-wire serial control of C-voice procedures	24
11、 Package size Figure.....	26

1、 Product features

- Package of 28 pins module, which can be replaced memory for gaining different lengths of storage time.
- Support SPI-Flash, which 's capacity is 2M bit ~ 32M (Note: 1byte = 8bit)
- WT588D-20SS voice used as a control core chip.
- Embedded human voice processor, feel very natural and sweet.
- Good audio quality output for 13Bit/DA converter and 12Bit/PWM processing of audio.
- Support for loading 6K ~ 22KHz audio sampling rate.
- PWM output can directly promote 0.5W/8Ω speakers and plenty of current.
- Support DAC / PWM output
- Support for loading WAV audio format.
- Support key control mode, one-wire serial control mode, three-wire serial control mode.
- A variety of IO trigger ways can be seted to in button control mode.
- The way of BUSY signal output can be set in a random manner.
- Loading no more than 500 segments voice for editing.
- Address bit is controled by 220 segments voice, but a single address bit just can load up to 128.
- Voice player to enter the sleep mode to stop immediately.
- It is simple interface and convenient because of using WT588D Voice Chip that benefited to exert its functions.
- A lot of operations can be finished in software. Such as setup control mode, inserting voice, compositing voice, calling voice, etc.
- Free to insert mute, mute time range 10ms ~ 25min.
- Support online USB download / offline USB download. What's more, it also can download data to SPI-Flash even if WT588D-U are working.
- Operating voltage: DC2.8V ~ 5.5V.

-
- dormant current less than 10uA
 - Powerful anti-jamming. Widely used in the industrial field.

2、 Functional Description

Button control mode is flexible to trigger and free to set any button to re-trigger .There are 15 trigger ways. Including trigger Impulse Repetition , trigger pluse Without Repetition , invalidation keys, no cycle Level , Recycled Level , Non-Maintained Cycle Level, Non-Cycle for The Last One ,Non-Cycle for The Next One , Cycle for The Last One , Cycle for The Next One, Volume +, Volume -, play / pause, stop, play / stop, etc . One-wire serial control mode and three-wire serial control mode, not only can control voice play, stop, loop play and volume size by the MCU, but also can direct triggering any voice in address bit from 0 to 219.

3、 application scopes

Widely range of applications. Almost related to all the voice places, such as Stop devices, annunciators , reminder, alarm clock, learning machine, intelligent home appliances, therapeutic equipment, electronic toys, telecommunications, reversing radar and a variety of automatic control devices, etc. Technology meet up to the requirements of industries application.

4、 Application block diagram

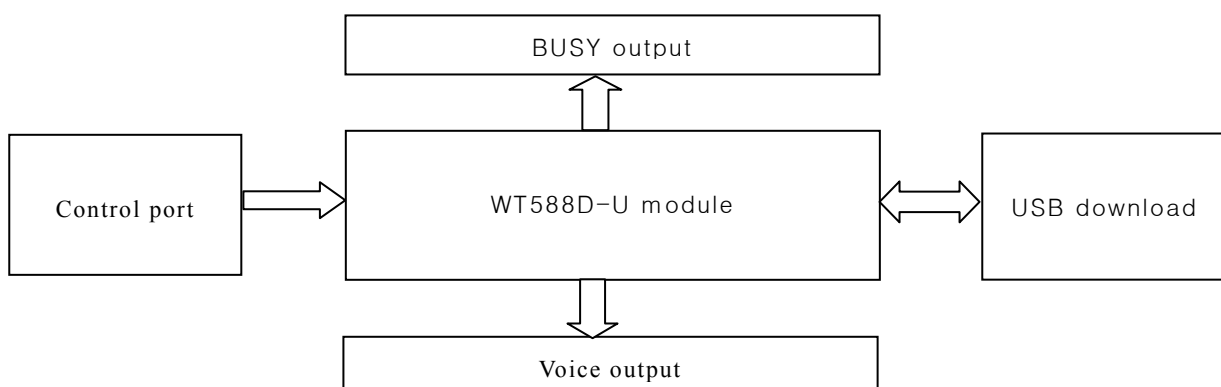

1	NC	VDD-USB	28
2	NC	D+	27
3	NC	D-	26
4	NC	GND	25
5	NC	NC	24
6	NC	NC	23
7	RESET	VDD	22
8	DAC	BUSY	21
9	PWM+	VCC	20
10	PWM-	P00	19
11	P14	P01	18
12	P13	P02	17
13	P16	P03	16
14	GND	P15	15

Pin Description

Package pins	Pins mark	Brief	Functional Description
1	NC	NC	blank
2	NC	NC	blank
3	NC	NC	blank
4	NC	NC	blank
5	NC	NC	blank
6	NC	NC	blank
7	RESET	RESET	Reset pin
8	DAC	DAC	DAC Audio output pin, need an external amplifier to drive speaker
9	PWM+	PWM+	PWM+ Audio output pin, which can directly drive speaker with the PWM-
10	PWM-	PWM-	PWM- Audio output pin, which can directly drive speaker with the PWM+
11	P14	SPI-FLASH_DI	use for external download manager
12	P13	SPI-FLASH_DO	use for external download manager
13	P16	SPI-FLASH_CLK	use for external download manager
14	GND	GND	GND
15	P15	SPI-FLASH_CS	use for external download manager
16	P03	K4/CLK/DATA	Button / three-wire clock / one-wire data input pin
17	P02	K3/CS	Button / three-wire chip input pin
18	P01	K2/DATA	Button / three-wire data input pin
19	P00	K1	Button
20	VCC	VCC	Analog power supply input pin

21	BUSY	BUSY	busy signal output pin
22	VDD	VDD	Data power supply input pin
23	NC	NC	blank
24	NC	NC	blank
25	GND	GND	USB GND
26	D-	USB_DATA-	USB data
27	D+	USB_DATA+	USB data
28	VDD_USB	VDD_USB	USB power positive

Note: Pin25,26,27,28 use to download for other USB slot.

6、electrical parameters

$V_{DD} - V_{SS} = 4.5V$, $T_A = 25^{\circ}C$, No load

Parameter	marker	Environmental conditions	min	Typical	Max	Units
Operating voltage	V_{DD}	$F_{sys}=8MHz$	2.8		5.5	V
Operating Current	I_{OP1}	No load	-	4.5	5.5	mA
Stop current	I_{DD2}	No load	-	1	2	uA
Dormancy current-mode	I_{OP2}	No load	-	650		uA
Low-voltage input	V_{IL}	All pin input	V_{SS}	-	$0.3V_{DD}$	V
high-voltage input	V_{IH}	All pin input	$0.7V_{DD}$	-	V_{DD}	V
Input currentBP1、BP2、RESET	I_{IN1}	$V_{IN}=0V$ Pull-up resistance=500K Ω	-5	-9	-14	uA
Input currentBP1、BP2、RESET	I_{IN2}	$V_{IN}=0V$ Pull-up resistance=150K Ω	-15	-30	-45	uA
output current (BP0)	I_{OL}	$V_{DD}=3V$, $V_{OUT}=0.4V$	8	12	-	mA
	I_{OH}	$V_{DD}=3V$, $V_{OUT}=2.6V$	-4	-6	-	mA
	I_{OL}	$V_{DD}=4.5V$, $V_{OUT}=1.0V$	-	25	-	mA
	I_{OH}	$V_{DD}=4.5V$, $V_{OUT}=2.6V$	-	-12	-	mA
output current (BP1)	I_{OL}	$V_{DD}=3V$, $V_{OUT}=0.4V$	4	10	-	mA
	I_{OH}	$V_{DD}=3V$, $V_{OUT}=2.6V$	-4	-6	-	mA
output current PWM+/PWM-	I_{OL1}	$RL=8\Omega$	+200	-	-	mA
	I_{OH1}	【 PWM+ 】 -- 【 RL 】 -- 【 PWM- 】	-200	-	-	mA
DAC Max current	I_{DAC}	$RL=100\Omega$	-2.4	-3.0	-3.6	mA
			-4.0	-5.0	-6.0	

Pull-up resistor test	R _{PL}		75	150	225	
-----------------------	-----------------	--	----	-----	-----	--

7、 Absolute limits of the environment parameters

parameters	marker	Environmental conditions	rating	units
power	V _{DD} - V _{SS}	-	-0.3 ~ +7.0	V
Input voltage	V _{IN}	input	V _{SS} -0.3 ~ V _{DD} +0.3	V
Storage temperature	T _{STG}	-	-55 ~ +150	°C
Used temperature	T _{OPR}	-	-40 ~ +85	°C

8、 control mode

8.1、 Buttons Control Mode

Pins can directly trigger a function of chip to work. Each pin of the trigger can be set individually. Shockproof time of this mode time is about 10ms. There are 15 trigger ways. Including trigger Impulse Repetition , trigger pluse Without Repetition , invalidation keys, no cycle Level , Recycled Level , Non-Maintained Cycle Level, Non-Cycle for The Last Tone ,Non-Cycle for The Next Tone , Cycle for The Last Tone , Cycle for The Next Tone, Volume +, Volume -, play / pause, stop, play / stop, etc. see the following trigger timing diagram. For more details, see the following chart:

8.1.1、 Trigger Impulse Repetition

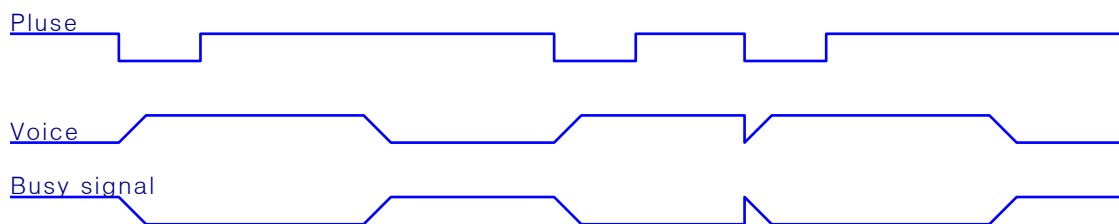

Note: Negative trigger pulse. When the I / O port inspects the falling edge (for example, the I / O port click short-circuit to GND), Voice will be broadcast .If do that again when the Voice are still playing, the

voice will be interrupted and replay. Therefore, it will be replay as long as has falling edge signal.

8.1.2、 Trigger Impluse Without Repetition

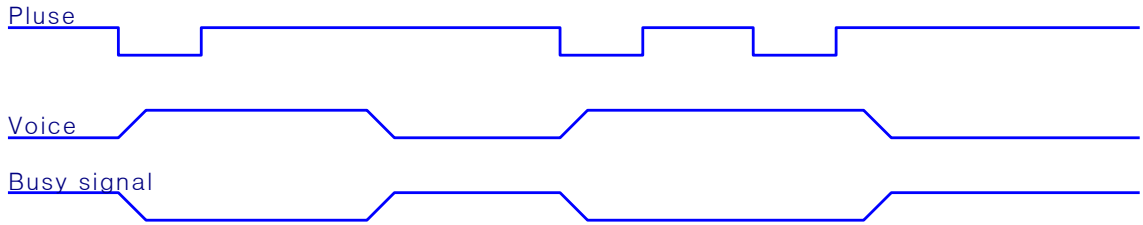

Note: Negative trigger pulse. When the I / O port inspects the falling edge (for example, the I / O port click short-circuit to GND), Voice will be broadcast. If do that again when the voice are still playing , the voice will not be interrupted and continue to broadcast. To be valid unless the voice at an end and inspects the falling edge.

8.1.3、 Recycled Level



Note: High level stops when the I / O port is low and keep play. Continue to keep a low level even if the first time is over. It will go along replay until change into high level. Low level has sound. High level hasn't.

8.1.4、 No Cycle Level

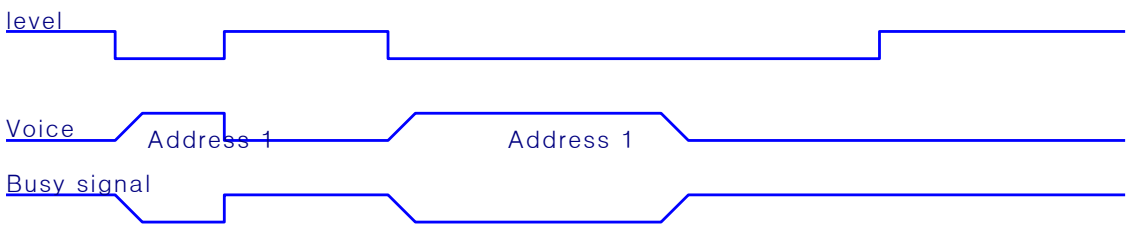

Note: Trigger level. High level stops when the I / O port is low and keep play. I will be not Continue to play even if the first time is over and keep a low level. The voice just play one time after being triggered.

If you need to replay, please make the I / O port at high level, and then pull low. Finally, keep it at low level .The end.

8.1.5、 Non-Maintained Cycle Level



Note: Negative Pulse /trigger Level. When the I / O port at low level and keep playing, at the same time, high level don't stop until the voice is over. When the end of the first time. If keep at the low level, it will continue to repeat .If not, when finish it will stop automatically.

8.1.6、 Play/Stop

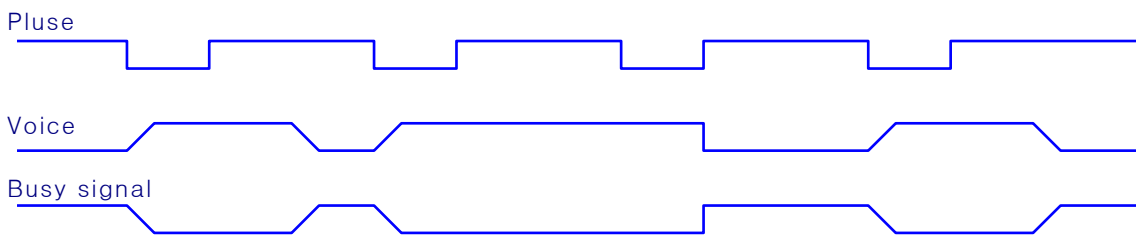

Note: Negative trigger pulse. Negative pulse starts to play when the next one stop. Whether the voice is in play or not must in accordance with this regulation.

8.1.7、 Non-Cycle for The Next Tone

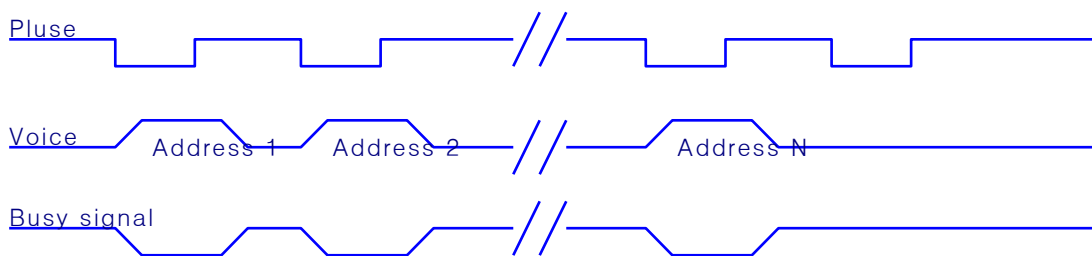

Note: Negative trigger pulse. Trigger with a button to play a sound. A pulse plays a piece, the next pulse plays the next piece .It doesn't stop until the last piece is finished. Repeat the same operation. Can only

play to the last.

8.1.8、 Non-Cycle for The Last Tone

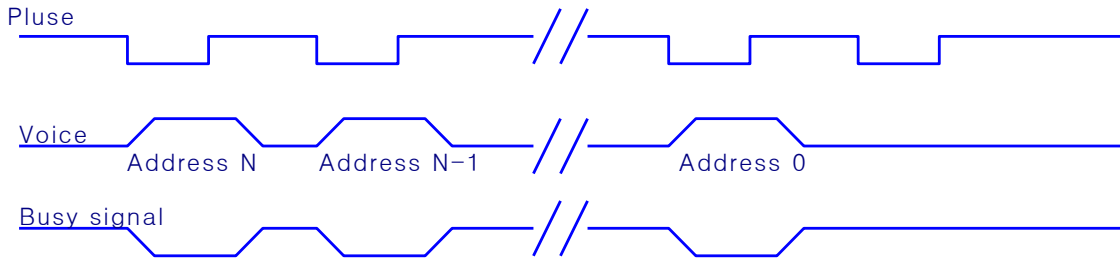

Note: Negative trigger pulse. Trigger with a button to play a sound. A pulse plays a piece, the next pulse plays the last piece. No longer trigger forward when the front voice is over. Repeat the operation, can only play to the last.

8.1.9、 Cycle for The Next Tone

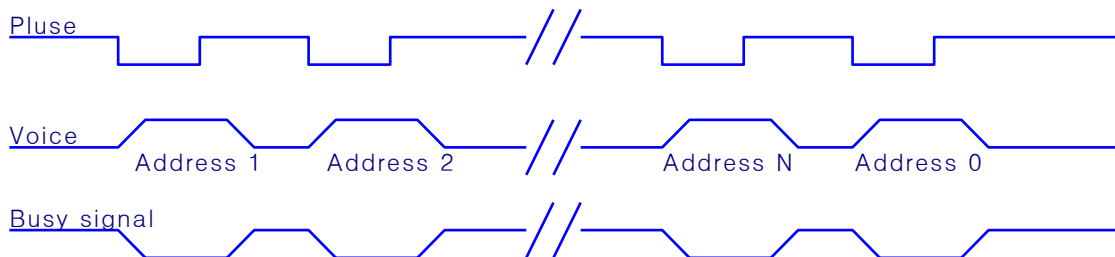

Note: Negative trigger pulse. Trigger with a button to play a sound. A pulse plays a piece , the next pulse plays the next piece. Repeat the operation. It will start again from the first piece when the last shows off. Loop continuously.

8.1.10、 Cycle for The Last Tone

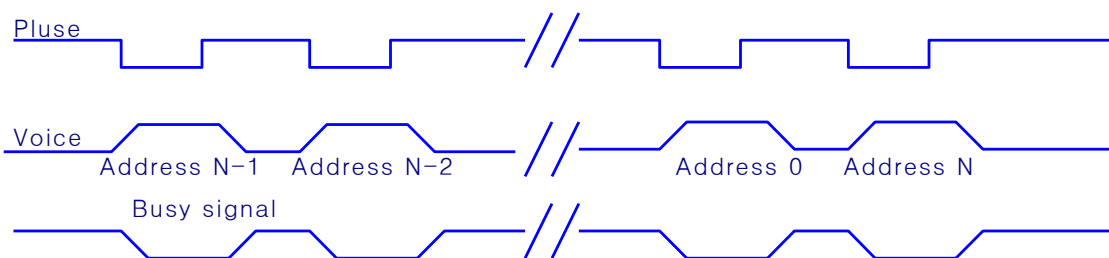

Note: Negative trigger pulse. Trigger with a button to play a sound. A pulse plays a piece, the next pulse plays the last piece. Repeat the operation. It will start again from the last piece when the front shows off. Loop continuously.

8.1.11、Pause

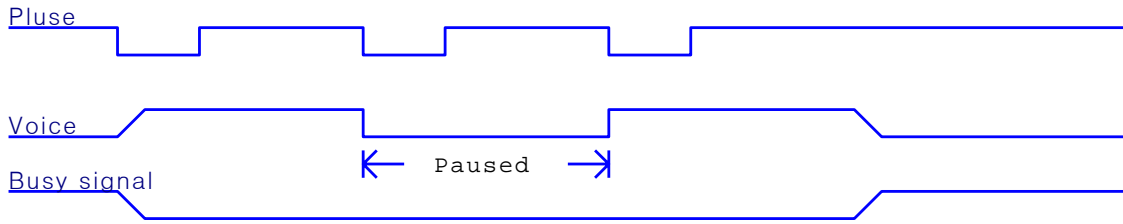

Note: Negative trigger pulse. The first pulse voice is playing but in a suspended state. The second pulse still working, which triggers the suspension of the voice. BUSY remain in this state.

8.1.12、Stop

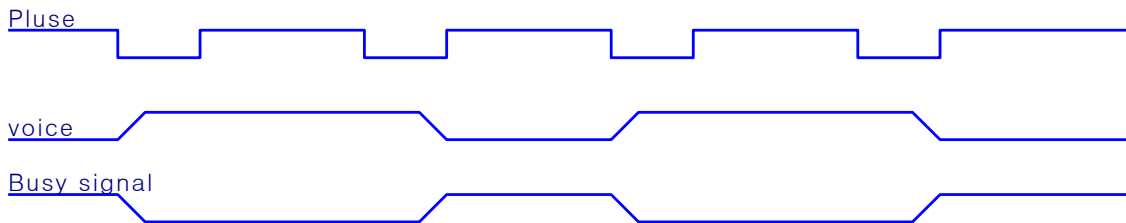

Note: Negative trigger pulse. Stopped the voice, which is playing . Trigger once again invalidly when the voice is stopped.

8.2、One-Wire Serial Port Control Mode

Send data through a data line. One-wire serial port can control voice play, stop, volume adjustment and directly trigger, etc. P00 ~ P02 I/O port can select screen or any trigger mode.

8.2.1、Port Allocation Table

I/O 口	P00	P01	P02	P03
-------	-----	-----	-----	-----

function	Key-press K1	Key-pressK 2	Key-pressK3	DATA
----------	-----------------	-----------------	-------------	------

8.2.2、 Order and Speech Cording

Commend code	Functions	Descriptions
E0H~E7H	volume adjustment	8 volume can be adjusted, E0H is minimum, E7H is the largest volume when working or standby.
F2H	Cycle play	the current voice addresses can be recycled When working.
FEH	Stop playing	Voice command to stop playing

8.2.3、 Voice Address Correspondence

Data (hex)	functions
00H	Play the zero piece voice
01H	Play the first piece voice
02H	Play the second piece voice
.....
D9H	Play the 217th piece voice
DAH	Play the 218th piece voice
DBH	Play the 219th piece voice

8.2.4、 Control Time Sequence Chart

One-wire serial port only through a data communication line control time sequence. According to different duty cycle of levels represent different data bit. Firstly, data signals is drawnd down 5ms, and then send data .The duty cycle of High level and low level 1:3 means data bit 0, if 3:1 means data bit 1, high in the former. Data signals send from low to high. When Send data, you just send address datum directly can trigger to play voice without sending command code and instruction. D0 ~ D7 means an address or command data. 00H ~ DBH of data send address order. E0H ~ E7H is volume adjustment order.F2H is Loop orders. FEH orders to stop playing. Details of time sequence in the following diagram:

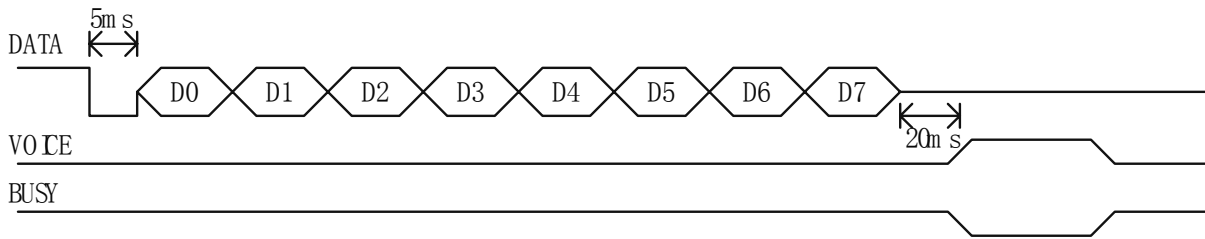

Description: WT588D-U can not enter dormant state under the one-wire serial interface. Therefore, using with caution when battery-powered .DATA is a communications line for one-wire serial interface, WT588D-U voice module begins to send data signals after current is switched on and wait 17ms.BUSY voice for the busy signal output. Wait for 20ms Data after sent successfully. And BUSY output will be to respond. Details of data bit duty cycle in the following chart:



High level: Low level=1: 3 means 0

High level: Low level =3: 1 means 1

8.2.5、 The Example of 1-Wire Serial Port Control Time Sequence

For example, Send time sequence of data 9CH chart in one-Wire Serial Port Control mode is show in figure:

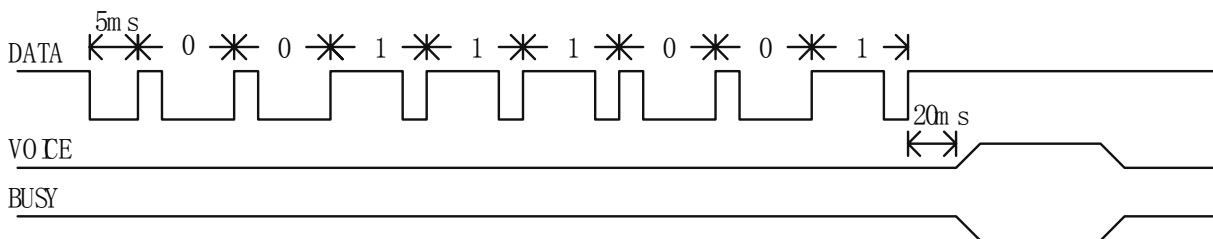

8.2.6、 Models of Procedure

```

Master SCM: PIC16F54, Clock frequency :4MHz
Send one-line (unsigned char addr)
{
sda=0;
delay1ms(5);      /* Data signals at low level 5ms */
for(i=0;i<8;i++)
{ sda=1;
if(addr & 1)

```

```

{ delay1us(600); /* High level: Low level =600us: 200us, means data=1 */
sda=0;
delay1us(200);}
else {
delay1us(600); /* High level: Low level =200us: 600us, means data=0 */
sda=0;
delay1us(200); }
addr>>=1; }
sda=1; }

```

8.3、 Three-Wire Serial Control mode

CS, DATA and CLK are composed of Three-Wire Serial Control mode .Time sequence according to SPI communication. Three-wire serial port can control command control and voice broadcast. All key-presses are not valid in the three-wire serial mode.

8.3.1、 Port Allocation Methods

I/O □	P00	P01	P02	P03
Functions	---	DATA	CS	CLK

8.3.2、 Voice and Command Code Corresponding to Table

Command Code	Functions	Description
E0H ~ E7H	Volume adjustment	8 volume can be adjusted, E0H is minimum, E7H is the largest volume when working or standby.
F2H	Cycle play	The current voice addresses can be recycled When working.
FEH	Stop playing	Voice command to stop playing

8.3.3、 Voice Address Corresponds

data (hex)	functions
00H	Play the zero piece voice
01H	Play the first piece voice
02H	Play the second piece voice

.....
D9H	Play the 217th piece voice
DAH	Play the 218th piece voice
DBH	Play the 219th piece voice

8.3.4、 Three-Wire Serial Port Control Time Sequence

CS, CLK and DATA pins are composed of Three-Wire Serial Control mode .Time sequence follows to SPI communication. CS downs to 5ms in order to wake-up WT588D-U voice module. Low bit receives data at the rising edge of CLK in the first place. Clock cycles between the range of 100us ~ 2ms, recommended 300us. The BUSY voice outputs in response to the successful reception of data. Data signals send from low to high. When Send data, you just send address datum directly can trigger to play voice without sending command code and instruction. D0 ~ D7 means an address or command data. 00H ~ DBH of data send address order. E0H ~ E7H is volume adjustment order.F2H is Loop orders. FEH orders to stop play. Details of time sequence in the following diagram:

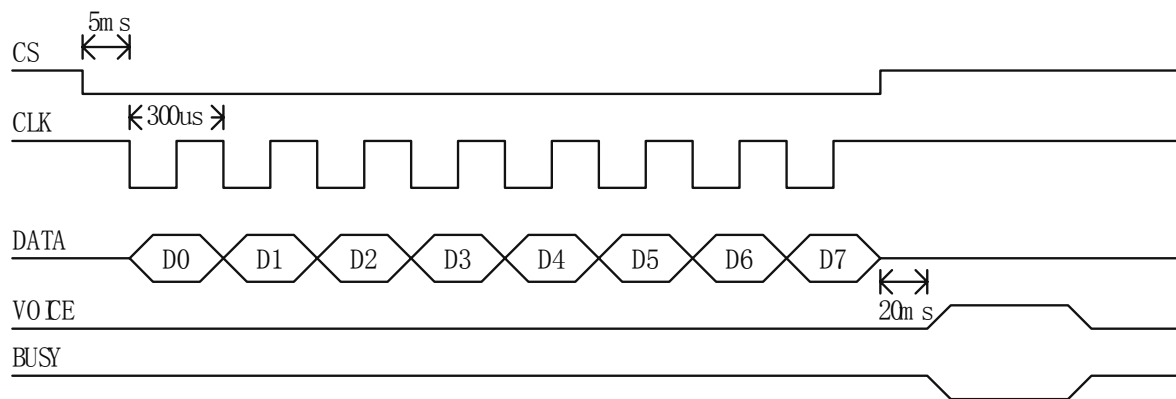

Description: WT588D-U voice module begins to send data signals after current is switched on and wait 17ms.

8.3.5、 Models of Procedure

```

(Master SCM PIC16F54, System frequency 4MHz)
Send threelines(unsigned char addr)
{ cs=0;
delay1ms(5);          /* Chip select signal keep low level 2ms */
for(i=0;i<8;i++)
{ scl=0;
if(addr & 1)sda=1;
else sda=0;
addr>>=1;
}
}

```

```

delay1us(300);          /* Clock cycle 300us */
scl=1;
delay1us(300);  }
cs=1;}

```

9、Typical Application Circuit

9.1、Typical Application Circuit of Key to Control(PWM output, 5V Supply)

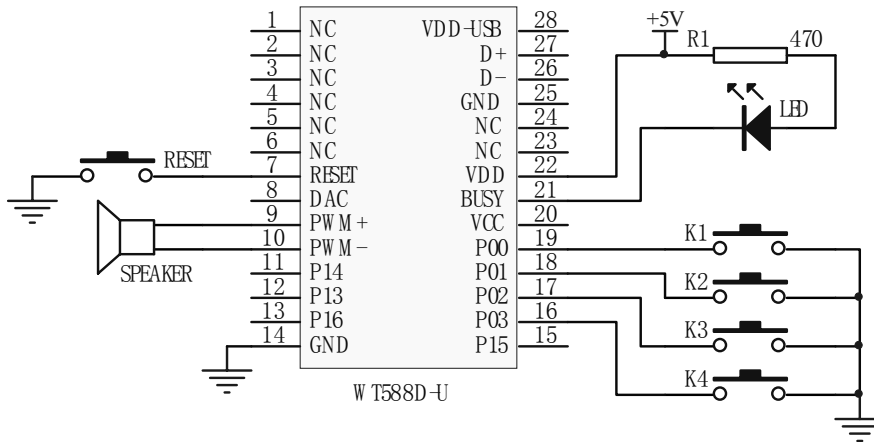

9.2、Typical Application Circuit of Keys to Control (PWM output, 3.3V Supply)

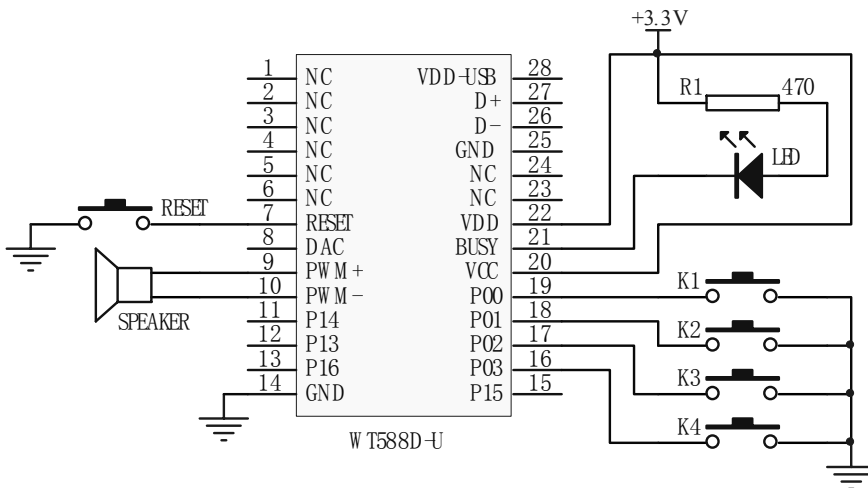

9.3、Typical Application Circuit of Keys to Control (DAC output)

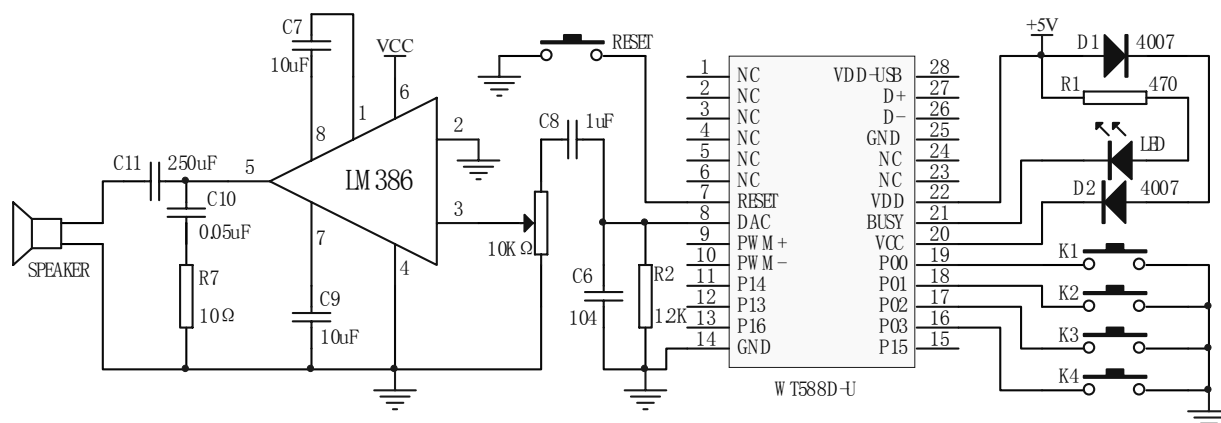

Note: DAC output port together with the ground, which connect with a 1.2K resistor and capacitor 104. when use DAC output way, and then the audio signal re-entering amplifier part, as circuit diagram of R2, R6 shown.

9.4、Typical Application of one-line Serial Control Circuit (PWM out)

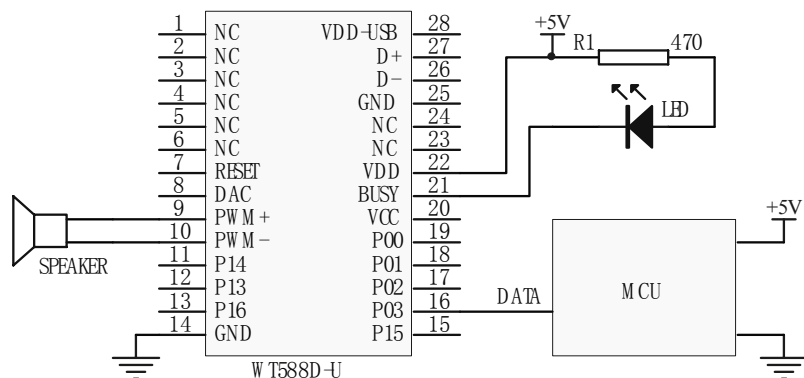

9.5、Typical Application of First-line Serial Control Circuit (DAC Output)

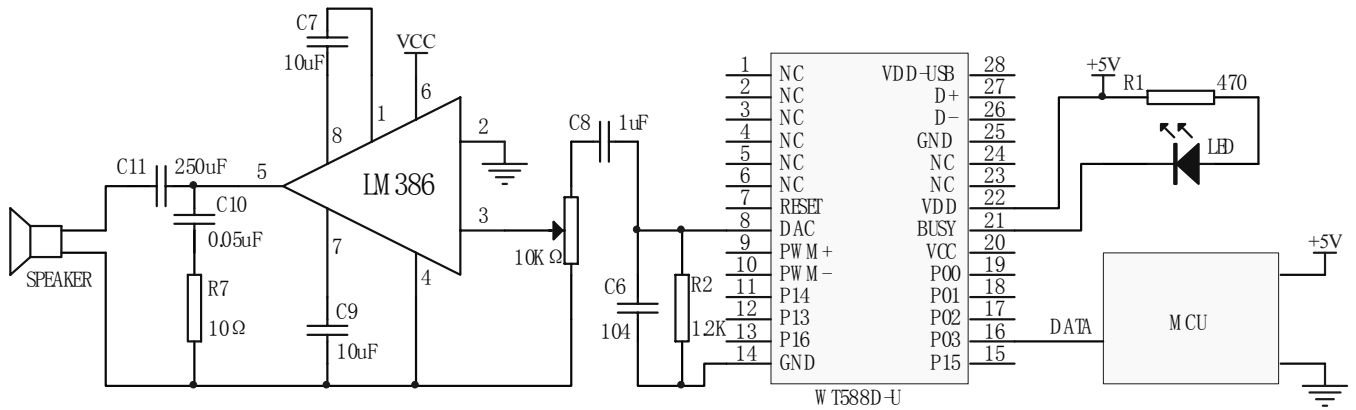

Note: DAC output port together with the land, which connect with a 1.2K resistor and capacitor 104. when use DAC output way, and then the audio signal re-entering amplifier part, as circuit diagram of R2, R6 shown.

9.6、One-Wire Serial Port MCU5V Power/ Module 3.3V Power Supply

Application circuit (PWM output)

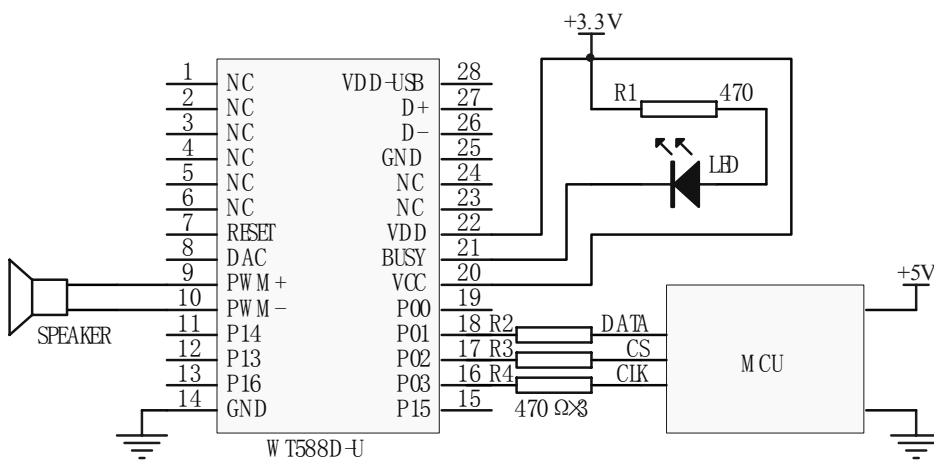

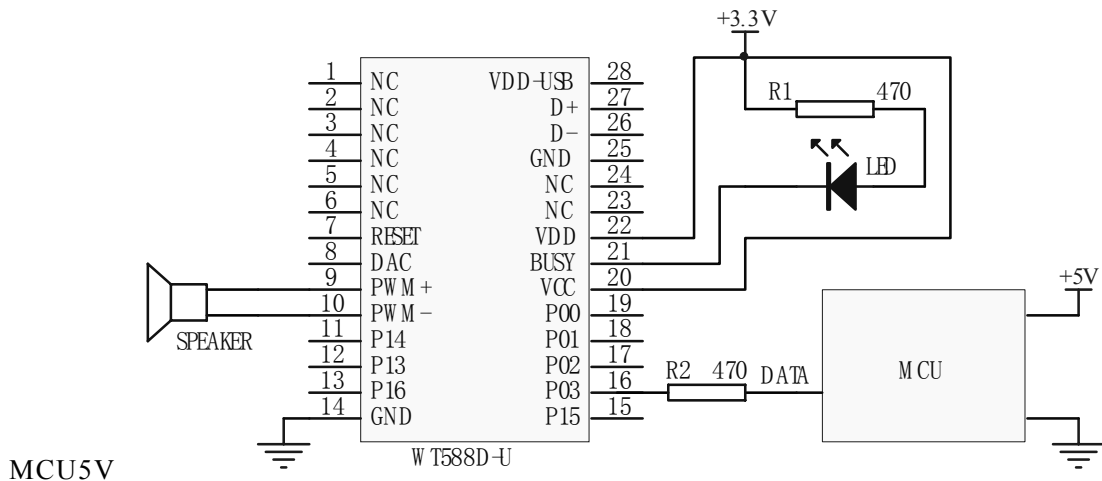

10、 Control procedures

10.1、 One-wire serial control of assembler

Description: This procedure is test program. Please change the IO port of MCU according to Practical application.

ORG 0000H

KEY EQU P1.1 ; Button pin

SDA EQU P3.0 ; Data pin

DAIFAZHI EQU 50H ; A temporary address for Code value

MOV DAIFAZHI,#0H; Code made the initial value of 0

MOV R5,#8 ; 8-bit Circulation of Fat Code

MAIN:

JB KEY,MAIN

MOV R6,#20 ;Delay 20MS

LCALL DELAY1MS

JB KEY,MAIN ; Buffeting button to judgment

JNB KEY,\$;Wait for button release

LCALL one-line ; Transfer one-wire fat code Subroutine

INC DAIFAZHI ; Code value plus 1 fat

MOV A,DAIFAZHI

CJNE A,#220,XX2 ;Whether reach max 220 of the Voice paragraph or not

XX2: JC XX3

MOV DAIFAZHI,#0H

XX3: LJMP MAIN

```

One-line:          ;/// one-wire fat code Subroutine
CLR SDA
MOV R6,#5          ; Delay 5MS
LCALL DELAY1MS
MOV A, DAIFAZHI
LOOP:  SETB SDA
RRC A
JNC DIDIANPIN     ; High level pulse   High: Low=3:1
LCALL DELAY200US
LCALL DELAY200US
LCALL DELAY200US
CLR SDA
LCALL DELAY200US
LJMP LOOP1
DIDIANPIN         ; Low level pulse   High: Low =1:3
LCALL DELAY200US
CLR SDA
LCALL DELAY200US
LCALL DELAY200US
LCALL DELAY200US
LOOP1:  DJNZ R5,LOOP
MOV R5,#08H
SETB SDA
RET
DELAY200US:  MOV R6,#100      ; Delay Subroutine 400US
DJNZ R6,$
RET
DELAY1MS:    ; Delay Subroutine 1ms, help R6 evaluate, Modified to extend the
time

L1:  MOV R7,#248
DJNZ R7,$
DJNZ R6,L1
RET
END

```

10.2、One-wire serial control of C-voice procedures

Description: This procedure is test program.Please change the IO port of MCU according to Practical application.

```

#include <at89x2051.H>
sbit KEY=P1^1; /* The 2nd of P1 port is P1_1 */

```

```

sbit SDA=P3^0; /* The 4th of P3 port is P3_0 P3_0 */
void delay1ms(unsigned char count) //1MS delay time Subroutine
{
    unsigned char i,j,k;
    for(k=count;k>0;k--)
        for(i=2;i>0;i--)
            for(j=248;j>0;j--);
}

void delay100us(unsigned char count) //100US Delay time Subroutine
{ unsigned char i;
  unsigned char j;
    for(i=count;i>0;i--)
        for(j=50;j>0;j--);
}

Send_oneline(unsigned char addr)
{
    unsigned char i;
    SDA=0;
    delay1ms(5);          /* delay 5ms */
    for(i=0;i<8;i++)
        {SDA=1;
        if(addr & 1)
            {delay100us(6);          /* 600us */
            SDA=0;
            delay100us(2);          /* 200us */
            }
        else {
            delay100us(2);          /* 200us */
            SDA=0;
            delay100us(6);          /* 600us */
            }
        addr>>=1; }
    SDA=1;
}

main()
{unsigned char FD=0;
  P3=0XFF;
  while(1)
  {

```

```

if(KEY==0)
{
    delay1ms(10);
    if(KEY==0)    // Increase Code value of fat by button P1.1.
    {
        Send online (FD);
        FD++;
        if(FD==220) // One-wire Serial port, the voice segment up to a maximum of 220
    {
        FD=0;
    }
    while(KEY==0); // Waiting for button release in order to avoid Miscarriage of justice
    }
}
}

```

10.3、 Three-wire serial control of assembler

Description: This procedure is test program. Please change the IO port of MCU according to Practical application.

```

        ORG 0000H
        KEY EQU P1.1    ; Button pin
        CS  EQU P3.1    ; CS trigger pin
        SCL EQU P3.2    ; Clock pin
        SDA EQU P3.0    ; Data pin
        DAIFAZHI EQU 50H; A temporary address for Code value
        MOV DAIFAZHI, #0H; Code made the initial value of 0
        MOV R5, #8      ; Code made the initial value of 0

MAIN:
        JB KEY, MAIN
        MOV R6, #20     ; Delay time 20MS
        LCALL DELAY1MS
        JB KEY, MAIN    ; Buffering button to judgment
        JNB KEY, $      ; Wait for button release
        LCALL THREE_LINE; Transfer three-wire fat code Subroutine
        INC DAIFAZHI    ; Code value plus 1 fat
        MOV A, DAIFAZHI
        CJNE A, #220, XX2 ; Whether reach max 220 of the Voice paragraph or not
XX2: JC XX3
        MOV DAIFAZHI, #0H

```

XX3: LJMP MAIN

```
THREE_LINE:           ;//// three-wire fat code Subroutine
    CLR CS
    MOV R6,#5          ; Dalay time 5MS
    LCALL DELAY1MS
    MOV A,DAIFAZHI
LOOP:
    CLR SCL
    RRC A
    MOV SDA,C
    LCALL DELAY50US
    SETB SCL
    LCALL DELAY50US
    DJNZ R5,LOOP
    MOV R5,#08H
    SETB CS
    RET
DELAY50US:    MOV R6,#150          ; Subroutine of dalay time 300US
    DJNZ R6,$
    RET
DELAY1MS:     ; Delay Subroutine 1ms, help R6 evaluate, Modified to extend the time

L1: MOV R7,#248
L2: NOP
    NOP
    DJNZ R7,L2
    DJNZ R6,L1
    RET
    END
```

10.4、 Three-wire serial control of C-voice procedures

Description: This procedure is test program.Please change the IO port of MCU according to Practical application.

```
#include <at89x51.H>
sbit KEY=P1^1; /* The 2nd of P1 port is P1_1 */
sbit CS=P3^1; /* The 3rd of P3 port is P3_1 */
sbit SCL=P3^2; /* The 4th of P3 port is P3_2 */
sbit SDA=P3^0; /* The 5th of P3 port is P3_0 */
```



```

//sbit DENG=P3^7; /* The 6th of P3 port is P3_5- */
void delay1ms(unsigned char count) //1MS Dalay time subroutine
{
    unsigned char i,j,k;
    for(k=count;k>0;k--)
        for(i=2;i>0;i--)
            for(j=248;j>0;j--);
}

void delay100us(void) //100US Dalay time subroutine
{
    unsigned char j;
    for(j=50;j>0;j--);
}

Send_threelines(unsigned char addr) // three-wire fat code Subroutine
{unsigned char i;
    CS=0;
    delay1ms(5);
    for(i=0;i<8;i++)
        {SCL=0;
        if(addr & 1)SDA=1;
        else SDA=0;
        addr>>=1;
        Delay300us(); /* 300us */
        SCL=1;
        Delay300us();
        }
    CS=1;
}

main()
{unsigned char FD=0;
    P3=0XFF;
    while(1)
    {
        if(KEY==0)
        {
            delay1ms(20);
            if(KEY==0) //Increase Code value of fat by button P1.1.
            {
                Send three-line (FD);
            }
        }
    }
}

```

```

    FD++;
    if(FD==220//Three-wire Serial port, the voice segment up to a maximum of 220
    {
        FD=0;
    }
    while(KEY==0); // Waiting for button release in order to avoid Miscarriage of justice
    }
}
}

```

11、 Package size Figure

Units: mm

