

# Nozzle Application Catalogue



*This catalogue describes a selection of our most widely used nozzles and their typical use in standard and special Surface Mount Applications.*

*Juki offers nozzles for specific applications and each special nozzle has been carefully engineered by our Application Specialists to ensure the highest quality product and ease of use.*

*A few examples of custom nozzles and their applications are illustrated in the section “ Special Applications “.*

*The “ Quick Reference Table “ provides the part numbers and descriptions.*

*This catalogue will be maintained periodically, please feel free to contact us for further assistance.*

*The Marketing Team  
marketing@jas-smt.com  
Juki Automation Systems AG  
Weissensteinstrasse 81  
CH-4500 Solothurn  
SWITZERLAND*

# TABLE OF CONTENTS

<b>1</b>	<b>Nozzle types</b> .....	<b>2</b>
1.1	Standard Application Nozzles .....	2
1.1.1	Type 1xx .....	2
1.1.2	Type 2xx .....	2
1.1.3	Type 5xx .....	2
1.2	Special Application Nozzles.....	3
1.2.1	Slot nozzles.....	3
1.2.2	Gripper nozzles .....	3
1.2.3	Pipe nozzle.....	3
<b>2</b>	<b>Nozzle selection</b> .....	<b>4</b>
2.1	Definition.....	4
2.2	Standard components Vs Standard nozzles.....	4
<b>3</b>	<b>Standard applications</b> .....	<b>5</b>
3.1	Flat Chips .....	5
3.2	MELFS.....	7
3.3	Tantalum Capacitors/ Inductors/ Potentiometers.....	8
3.4	Electrolytic Capacitors .....	9
3.5	Transistors/ Diodes .....	11
3.6	Small Outlines .....	12
3.7	Plastic Leaded Chip Carriers.....	14
3.8	PLCC Sockets .....	15
3.9	Quad Flat Packs .....	16
3.10	Ball Grid Arrays .....	17
3.11	PCB Connectors.....	18
<b>4</b>	<b>Customized nozzles</b> .....	<b>20</b>
4.1	Slot Nozzles.....	20
4.1.1	700 Models .....	20
4.1.2	2000/ FXI Models.....	22
4.2	Gripper Nozzles.....	24
4.2.1	700 Models .....	24
4.2.2	2000/ FXI Models.....	26
4.3	Pipe Nozzles.....	27
4.3.1	700 Models .....	27
4.3.2	2000/ FXI Models.....	28
<b>5</b>	<b>Special Applications</b> .....	<b>29</b>
<b>6</b>	<b>Quick reference table</b> .....	<b>34</b>
6.1	Standard Nozzles .....	34
6.2	Gripper Nozzles.....	35

## I NOZZLE TYPES

Juki's modular placement heads and a wide selection of nozzles provide effective placement solutions for the most comprehensive list of components in the electronic industry, including 0201 chips, fine pitch packages, advanced packages and odd form components.

The nozzles are classified into two major types.

- Standard Application Nozzles
- Special Application Nozzles

The nozzle body and the tip are made of copper alloy to ensure the pick reliability and nozzle durability. This feature guarantees an excellent stability of the narrow tip nozzles for 0201, 0402, 0603 chip components.

Fine pitch placement nozzle tips are mounted with polyurethane cups to avoid skewing, which permits accurate placement.

Each vacuum nozzle is numbered with reference to the machine model, type of placement head, profile of the nozzle tip and the suction area.

### I.1 Standard Application Nozzles



Type 1xx, 2xx & 5xx

The standard nozzles are designed for most typical SMT applications; the best selection should cover a wide variety of components.

The nozzle numbers 1xx, 2xx and 5xx are reserved for standard types.

#### I.1.1 Type 1xx

Type 1xx nozzles are designed for the machine models 700 and are used only on the placement heads with Laser Alignment.



There are six standard 1xx nozzles, ranging from 101 to 106.

750

Model 750 has three-placement heads with Laser Alignment.

#### I.1.2 Type 2xx



760

Type 2xx nozzles are designed for the machine models 700 and are used only on the placement heads with Vision Alignment.

There are four standard 2xx nozzles,

ranging from 201 to 204.

Model 760 has the left side placement head with Laser Alignment & the right side placement head with Vision Alignment.

#### I.1.3 Type 5xx

Type 5xx nozzles are designed for the machine models 2000 and are used on the placement heads with Vision & Laser Alignment.

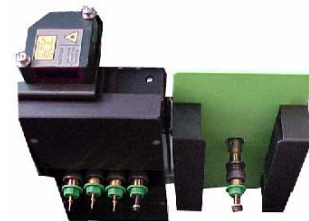

5xx type nozzles are compatible with all types of heads of the 2000 models.

There are eight standard 5xx nozzles, ranging from 501 to 508.

Model 2020 & 2060 has one multi-nozzle placement head with Laser Alignment and one placement head with Vision Alignment.

Machine Model	Applicable Nozzle Type
750	1xx
760	1xx and 2xx
2010	5xx
2020	5xx
2030	5xx
2040	5xx
2050	5xx
2060	5xx
FXI	5xx

### 1.2 Special Application Nozzles

Odd-Form components, Special connectors are any devices that cannot be easily handled by standard nozzles, because of the varying shapes and sizes.

Juki have designed a wide range of Slot, Gripper and Pipe nozzles for handling special components.

Each nozzle has been developed for a specific customer requirement.

Customized nozzles are compatible with the standard nozzle slider shaft and the standard Automatic Tool Changer. Each special nozzle package for 2000 series will be supplied with the nozzle configuration software.

In other words, JUKI customized nozzles have the ease of a Plug & Play feature without any modifications required to the standard machine configuration.

#### 1.2.1 Slot nozzles



Slot Nozzles - 700 Models

Slot nozzles have a tip with a narrow rectangular cross section for easy entry into a slot.

These nozzles are generally used to assemble a variety of board to board and ribbon cable connectors. A wide range of slot widths and slot lengths are available.



Slot nozzle applications with an inductor and a connector

#### 1.2.2 Gripper nozzles

Gripper nozzles have a fixed arm and a swing arm that enables it to grab odd shape components.



Gripper Nozzle - 700 Models

These nozzles are available with the gripping range from 0.8 mm to 5.2 mm.

Odd form components, special connectors, hybrid circuits are typical applications for Gripper nozzles.



Gripper nozzle with a hybrid circuit

#### 1.2.3 Pipe nozzles



Pipe Nozzles - 700 Models

Pipe nozzles have big suction areas that facilitate the pick-up of large components.

Varying inner diameters help to assemble different forms of sockets and shields.



Pipe nozzle with a potentiometer

A pipe nozzle with a set of interchangeable rubber tips is designed for mounting dies.

Pipe nozzle with interchangeable rubber tips



# NOZZLE SELECTION

## I.3 Definition

Nozzle selection depends on the type and the outer dimensions of the components. The nozzle numbers and the vacuum pressures in the production program data are defined according to the minimum width or diameter D of the components to be picked.

When selecting nozzles for non-standard shape components, the nozzle numbers and the vacuum pressures are to be entered manually, in the production program data.

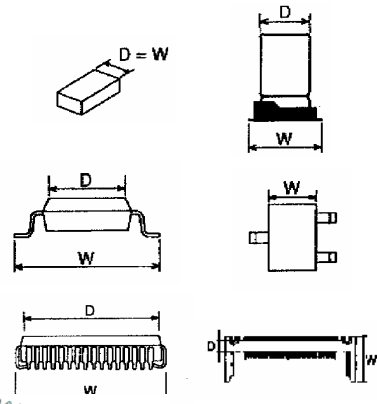

## I.4 Standard components Versus Standard nozzles

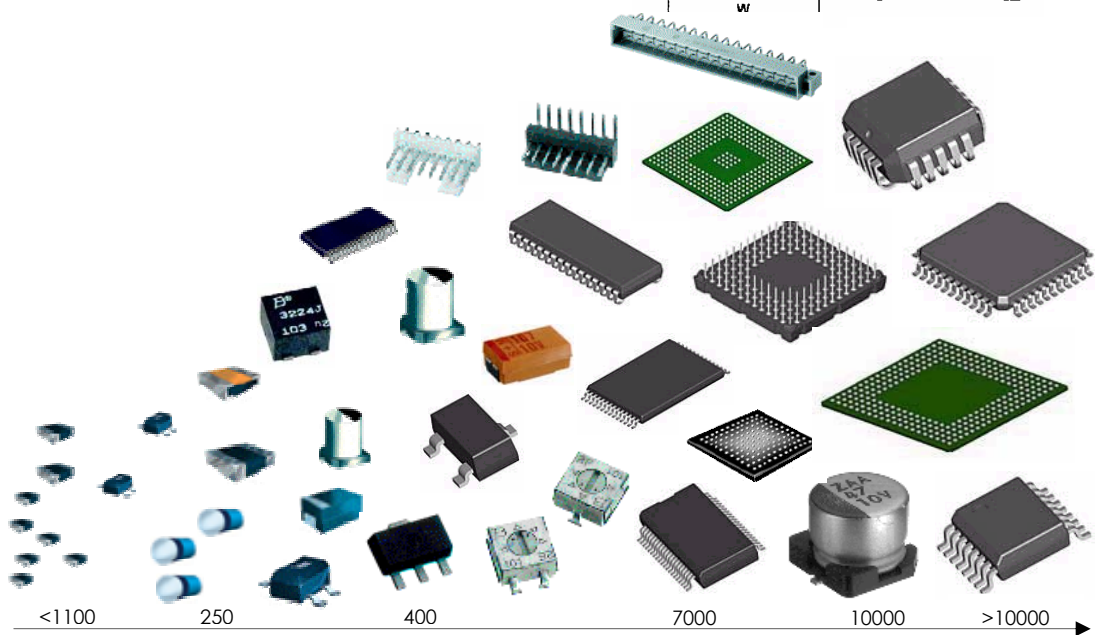

Component width (D in)











## 2 STANDARD APPLICATIONS

### 2.1 Flat Chip



Component Designation	Length (μm)	Width (μm)	Height (μm)	Nozzle Type		
Flat Chip 0201	600	300	300	100	X	501
Flat Chip 0402	1000	500	200	101	X	502
Flat Chip 0603	1600	800	300	101	X	503
Flat Chip 0805	2000	1250	400	102	X	503
Flat Chip 1206	3200	1600	500	102	X	504
Flat Chip 1210	3200	2600	500	103	X	505
Flat Chip 2010	5000	2500	500	103	X	505
Flat Chip 2512	6300	3100	500	103	X	505

Nozzle	Type	Machine model	Tip Outer φ (mm)	Tip Inner φ (mm)	Applicable component Width	Vision	Laser	
	101	750 760	1.0	0.4	$D < 1.1$	NA	√	
	102	750 760	1.5	1.0	$1.1 \leq D < 2.5$	NA	√	
	103	750 760	3.0	1.7	$2.5 \leq D < 4.0$	NA	√	
	501	2010 2020 2030 2040	2050 2060 FXI	0.7 * 0.4	2 * 0.2	$D < 0.45$	√	√
	502	2010 2020 2030 2040	2050 2060 FXI	0.7	0.4	$0.45 \leq D < 0.75$	√	√
	503	2010 2020 2030 2040	2050 2060 FXI	1.0	0.6	$0.75 \leq D < 1.45$	√	√

	504	2010 2020 2030 2040	2050 2060 FXI	1.5	1.0	$1.1 \leq D < 2.5$	√	√
	505	2010 2020 2030 2040	2050 2060 FXI	3.5	1.7	$2.5 \leq D < 4.0$	√	√



2.2 MELFS







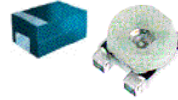

Component Designation	Length (μm)	Width (μm)	Height (μm)	Nozzle Type		
MELF	2000	φ1350	-	102	X	510
MELF	3200	φ1750	-	102	X	510
MELF	3500	φ1550	-	102	X	510
MELF	5900	φ2400	-	102	X	511

Nozzle	Type	Machine model		Tip Outer φ (mm)	Tip Inner φ (mm)	Applicable component Width	Vision	Laser
	102	750	760	1.5	1.0	$1.1 \leq D < 2.5$	NA	√
	510	2010 2020 2030 2040	2050 2060 FXI	1.5	0.6	$1.6 \leq D < 3.5$	√	√
	511	2010 2020 2030 2040	2050 2060 FXI	2.0	1.2	$D \leq 5.9$	√	√

### 2.3 Tantalum Capacitors/ Inductors/ Potentiometers









Component Designation	Length (μm)	Width (μm)	Height (μm)	Nozzle Type		
Potentiometer	3000	3400	1500	103	X	505
Potentiometer	3800	4500	1650	104	X	506
Potentiometer	4000	4500	2400	104	X	506
Inductor Chip	2500	2000	1800	102	X	504
Inductor Chip	3200	2500	2200	103	X	505
Inductor Ferrite Core	4000	4300	4300	104	X	506
Tantalum Capacitor	2000	1250	1200	102	X	503
Tantalum Capacitor	3200	1600	1600	102	X	504
Tantalum Capacitor	3400	2600	1900	103	X	505

Nozzle	Type	Machine model		Tip Outer φ (mm)	Tip Inner φ (mm)	Applicable component Width	Vision	Laser
	102	750	760	1.5	1.0	$1.1 \leq D < 2.5$	NA	√
	103	750	760	3.0	1.7	$2.5 \leq D < 4.0$	NA	√
	104	750	760	4.0	3.2	$4.0 \leq D < 7.0$	NA	√
	503	2010 2020 2030 2040	2050 2060 FXI	1.0	0.6	$0.75 \leq D < 1.45$	√	√
	504	2010 2020 2030 2040	2050 2060 FXI	1.5	1.0	$1.1 \leq D < 2.5$	√	√
	505	2010 2020 2030 2040	2050 2060 FXI	3.5	1.7	$2.5 \leq D < 4.0$	√	√
	506	2010 2020 2030 2040	2050 2060 FXI	5.0	3.2	$4.0 \leq D < 7.0$	√	√

## 2.4 Electrolytic Capacitors



Component Designation	Length (μm)	Width (μm)	Height (μm)	Nozzle Type		
Electrolytic Capacitor	3300	φ 3000	5400	103	X	505
Electrolytic Capacitor	4300	φ 4000	5400	103	X	506
Electrolytic Capacitor	5300	φ 5000	5400	104	X	506
Electrolytic Capacitor	6600	φ 6300	5400	104	X	506
Electrolytic Capacitor	6600	φ 6300	7900	104	X	506
Electrolytic Capacitor	8300	φ 8000	6200	105	X	507
Electrolytic Capacitor	8300	φ 8000	10200	105	X	507
Electrolytic Capacitor	10300	φ 10000	10200	106	X	508







Nozzle	Type	Machine model		Tip Outer φ (mm)	Tip Inner φ (mm)	Applicable component Width	Vision	Laser
	103	750	760	3.0	1.7	$2.5 \leq D < 4.0$	NA	
	104	750	760	4.0	3.2	$4.0 \leq D < 7.0$	NA	√
	105	750	760	6.5	5.0	$7.0 \leq D < 10.0$	NA	√
	106	750	760	9.5	8.0	$10.0 \leq D$	NA	√
	505	2010 2020 2030 2040	2050 2060 FXI	3.5	1.7	$2.5 \leq D < 4.0$	√	√
	506	2010 2020 2030 2040	2050 2060 FXI	5.0	3.2	$4.0 \leq D < 7.0$	√	√
	507	2010 2020 2030 2040	2050 2060 FXI	8.5	5.0	$7.0 \leq D < 10.0$	√	√

	508	2010 2020 2030 2040	2050 2060 FXI	9.5	8.0	$10.0 \leq D$	√	√
---	-----	------------------------------	---------------------	-----	-----	---------------	---	---

## 2.5 Transistors/ Diodes









Component Designation	Length (μm)	Width (μm)	Height (μm)	Nozzle Type		
Transistor SC90	1600	800	700	101	X	503
Transistor SOT323	2000	1250	900	102	X	503
Transistor SOT343	2000	1250	1100	102	X	503
Transistor SOT353	2000	1250	1100	102	X	503
Transistor SOT363	2000	1250	1100	102	X	503
Transistor SOT23	2900	1300	950	102	X	503
Transistor SOT143	2900	1600	950	102	X	504
Transistor SOT25	2900	1600	1100	102	X	504
Transistor SOT26	2900	1600	1100	102	X	504
Transistor DPAK	9900	6500	4700	104	X	506
Diode SOD123	3700	1550	1400	102	X	504
Diode SOD323	2500	1250	1200	102	X	503

Nozzle	Type	Machine model	Tip Outer φ (mm)	Tip Inner φ (mm)	Applicable component Width	Vision	Laser	
	101	750 760	1.0	0.4	$D < 1.1$	NA	√	
	102	750 760	1.5	1.0	$1.1 \leq D < 2.5$	NA	√	
	104	750 760	4.0	3.2	$4.0 \leq D < 7.0$	NA	√	
	503	2010 2020 2030 2040	2050 2060 FXI	1.0	0.6	$0.75 \leq D < 1.45$	√	√
	504	2010 2020 2030 2040	2050 2060 FXI	1.5	1.0	$1.1 \leq D < 2.5$	√	√
	506	2010 2020 2030 2040	2050 2060 FXI	5.0	3.2	$4.0 \leq D < 7.0$	√	√

## 2.6 Small Outlines

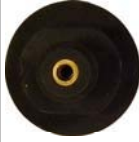

Component Designation	Length (μm)	Width (μm)	Height (μm)	Nozzle Type		
SO6 * 1.27p	3800	6000	1450	104	202	506
SO8 * 1.27p	4900	6000	1550	104	202	506
SO14 * 1.27p	8650	6000	1550	104	202	506
SO16 * 1.27p	10000	6000	1600	104	202	506
SO8L * 1.27p	8000	10300	2500	106	203	508
SO14L * 1.27p	9100	10320	2500	106	203	508
SO16L * 1.27p	10280	10300	2500	106	203	508
SO18L * 1.27p	11550	10300	2500	106	203	508
SO20L * 1.27p	12800	10325	2500	106	203	508
SO24L * 1.27p	15400	10325	2500	106	203	508
SO28L * 1.27p	18000	10300	2450	106	203	508
SO32L * 1.27p	21000	10600	2670	106	203	508
SO40L * 1.27p	26600	11800	2900	106	203	508
SOJ24 * 1.27p	15880	8660	3500	105	203	507
SOJ26 * 1.27p	17150	8660	3500	105	203	507
SOJ28 * 1.27p	18410	8660	3500	105	203	507
SOJ32 * 1.27p	20960	8510	3500	105	203	507
TSOP24 * 0.5p	16000	6000	1200	X	202	506
TSOP32 * 0.5p	20000	8000	1000	X	203	507
TSOP40 * 0.5p	20000	10100	1200	X	203	508
SSOP8 * 0.65p	3000	7800	1800	105	203	507
SSOP14 * 0.65p	6200	7800	1800	105	203	507
SSOP16 * 0.65p	6200	7800	1800	105	203	507
SSOP18 * 0.65p	7200	7800	1800	105	203	507
SSOP20 * 0.65p	7200	7800	1800	105	203	507
SSOP22 * 0.65p	9200	7800	1800	105	203	507
SSOP24 * 0.65p	9200	7800	1800	105	203	507
SSOP28 * 0.65p	10200	7800	1800	105	203	507
SSOP30 * 0.65p	10200	7800	1800	105	203	507
SSOP34 * 0.65p	118100	10250	2600	106	203	508
SSOP36 * 0.65p	15600	10350	2600	106	203	508
SSOP38 * 0.65p	12600	7800	1800	105	203	507
SSOP44 * 0.65p	17900	10300	2515	106	203	508
SSOP48 * 0.65p	15880	10310	2590	106	203	508
SSOP56 * 0.65P	18400	19350	2600	106	203	508
SSOP64 * 0.65p	26300	14250	2100	106	203	508

Nozzle	Type	Machine model		Tip Outer $\phi$ (mm)	Tip Inner $\phi$ (mm)	Applicable component Width	Vision	Laser
	104	750	760	4.0	3.2	$4.0 \leq D < 7.0$	NA	√
	105	750	760	6.5	5.0	$7.0 \leq D < 10.0$	NA	√
	106	750	760	9.5	8.0	$10.0 \leq D$	NA	√
	202	760		5.5	3.2	$4.0 \leq D < 7.0$	√	√
	203	760		8.5	5.0	$7.0 \leq D < 20.0$	√	√
	506	2010 2020 2030 2040	2050 2060 FXI	5.0	3.2	$4.0 \leq D < 7.0$	√	√
	507	2010 2020 2030 2040	2050 2060 FXI	8.5	5.0	$7.0 \leq D < 10.0$	√	√
	508	2010 2020 2030 2040	2050 2060 FXI	9.5	8.0	$10.0 \leq D$	√	√

## 2.7 Plastic Leaded Chip Carriers



Component Designation	Length (μm)	Width (μm)	Height (μm)	Nozzle Type		
PLCC20 * 1.27p	9850	9850	4350	105	203	507
PLCC28 * 1.27p	12350	12350	4350	106	203	508
PLCC44 * 1.27p	17550	17550	4350	106	203	508
PLCC52 * 1.27p	20050	20050	4600	106	204	508
PLCC68 * 1.27P	25150	25150	4600	106	204	508
PLCC84 * 1.27p	30230	30230	4600	106	204	508
PLCC100 * 1.27p	35350	35350	4600	106	204	508
PLCC124 * 1.27p	42950	42950	4600	106	204	508





Nozzle	Type	Machine model		Tip Outer φ (mm)	Tip Inner φ (mm)	Applicable component Width	Vision	Laser
	105	750	760	6.5	5.0	$7.0 \leq D < 10.0$	NA	√
	106	750	760	9.5	8.0	$10.0 \leq D$	NA	√
	203	760		8.5	5.0	$7.0 \leq D < 20.0$	√	√
	204	760		9.5	8.0	$20.0 \leq D$	√	√
	507	2010 2020 2030 2040	2050 2060 FXI	8.5	5.0	$7.0 \leq D < 10.0$	√	√
	508	2010 2020 2030 2040	2050 2060 FXI	9.5	8.0	$10.0 \leq D$	√	√

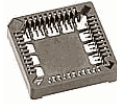

## 2.8 PLCC Sockets







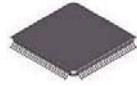

Component Designation	Length (μm)	Width (μm)	Height (μm)	Nozzle Type		
Socket PLCC28	17000	17000	1500	106	203	508
Socket PLCC32	20300	17800	1500	106	203	508
Socket PLCC44	22900	22900	1500	106	204	508
Socket PLCC52	25500	25500	1500	106	204	508
Socket PLCC68	30500	30500	1500	106	204	508
Socket PLCC84	35700	35700	1500	106	204	598

Nozzle	Type	Machine model	Tip Outer φ (mm)	Tip Inner φ (mm)	Applicable component Width	Vision	Laser
	106	750 760	9.5	8.0	$10.0 \leq D$	NA	√
	203	760	8.5	5.0	$7.0 \leq D < 20.0$	√	√
	204	760	9.5	8.0	$20.0 \leq D$	√	√
	508	2010 2020 2030 2040	9.5	8.0	$10.0 \leq D$	√	√

## 2.9 Quad Flat Packs

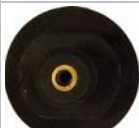

Component Designation	Length (μm)	Width (μm)	Height (μm)	Nozzle Type		
TQFP32 * 0.8p	7000	7000	1000	105	202	507
TQFP44 * 0.8p	10000	10000	1000	106	203	508
TQFP48 * 0.5p	7000	7000	1000	X	202	507
TQFP52 * 0.65p	10000	10000	1000	106	203	508
TQFP64 * 0.4p	7000	7000	1000	X	202	507
TQFP80 * 0.4p	10000	10000	1000	X	203	508
TQFP100 * 0.5p	19700	19700	1000	X	203	508
TQFP120 * 0.4p	15700	15700	1000	X	203	508
TQFP144 * 0.5p	20000	20000	1000	X	203	508
QFP44 * 0.8p	10000	10000	2000	106	203	508
QFP52 * 0.65p	10000	10000	2000	106	203	508
QFP64 * 0.8p	14000	14000	2000	106	203	508
QFP80 * 0.8p	20000	14000	2700	106	203	508
QFP100 * 0.65p	20000	14000	2700	106	203	508

Nozzle	Type	Machine model		Tip Outer φ (mm)	Tip Inner φ (mm)	Applicable component Width	Vision	Laser
	105	750	760	6.5	5.0	$7.0 \leq D < 10.0$	NA	√
	106	750	760	9.5	8.0	$10.0 \leq D$	NA	√
	202	760		5.5	3.2	$4.0 \leq D < 7.0$	√	√
	203	760		8.5	5.0	$7.0 \leq D < 20.0$	√	√
	507	2010 2020 2030 2040	2050 2060 FXI	8.5	5.0	$7.0 \leq D < 10.0$	√	√
	508	2010 2020 2030 2040	2050 2060 FXI	9.5	8.0	$10.0 \leq D$	√	√

## Ball Grid Arrays

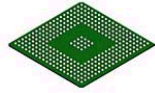



Component Designation	Length (μm)	Width (μm)	Height (μm)	Nozzle Type		
BGA 144 * 1p	13000	13000	1660	106	203	508
BGA 156 * 1p	15000	15000	1660	106	203	508
BGA 192 * 1p	17000	17000	1660	106	203	508
BGA 288 * 1p	23000	23000	1660	106	204	508
BGA 400 * 1p	21000	21000	1660	106	204	508





Nozzle	Type	Machine model		Tip Outer φ (mm)	Tip Inner φ (mm)	Applicable component Width	Vision	Laser
	106	750	760	9.5	8.0	10.0 ≤ D	NA	√
	203	760		8.5	5.0	7.0 ≤ D < 20.0	√	√
	204	760		9.5	8.0	20.0 ≤ D	√	√
	508	2010 2020 2030 2040	2050 2060 FXI	9.5	8.0	10.0 ≤ D	√	√

## 2.10 PCB Connectors



Component Designation	Length (μm)	Width (μm)	Height (μm)	Nozzle Type		
Connector -MOLEX 12P * 1p	4500	9100	2000	X	202	507
Connector -MOLEX 12P * 1p	4500	9600	2000	X	202	507
Connector -MOLEX 80P * 0.6p	42000	6800	8700	X	202	506
Connector 4P	4500	4000	500	I02		506
Connector 20P	4100	9800	1000	I02		507
Connector 20P	2300	8900	4500	I03		507
Connector 2P	5400	8400	1800	I02		505
Connector 1P	3100	3400	500	I02		505
Connector 5P	7000	12600	5000	I05		508
Connector 2P	5800	7400	2700	I03		507
Connector 4P	3600	4100	1700	I03		506
Connector 28P	14800	32900	6000	I05		508
Connector 2P	3400	5600	1900	I02		506
Connector 2P	3800	7200	1800	I02		507
Connector -AMP 10P * 1.25p	7700	5900	4650	I04		506
Connector -AMP 6P * 1.25p	5200	5600	3500	I03		506
Connector -AMP 30P * 1.25p	20200	5600	3500	I03		506
Connector 24P * 1.25p	16450	5900	4650	I04		506
Connector -AMP 80P * 0.8p	42000	6800	8600	X	202	506
Connector -AMP 80P * 0.8p	42000	6400	5600	X	202	506
Connector -AMP 40P * 0.8p	26000	6400	5500	I05		506
Connector -AMP 5P * 2p	15400	10400	5800	I04		508
Connector 2P * 1.25p	7450	6700	2500	I03		506
Connector 2P * 1.25p	7150	4900	4800	I02		506

Nozzle	Type	Machine model	Tip Outer φ (mm)	Tip Inner φ (mm)	Applicable component Width	Vision	Laser
	I02	750 760	1.5	1.0	$1.1 \leq D < 2.5$	NA	√
	I03	750 760	3.0	1.7	$2.5 \leq D < 4.0$	NA	√
	I04	750 760	4.0	3.2	$4.0 \leq D < 7.0$	NA	√







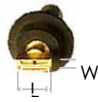

	105	750 760		6.5	5.0	$7.0 \leq D < 10.0$	NA	√
	505	2010 2020 2030 2040	2050 2060 FXI	3.5	1.7	$2.5 \leq D < 4.0$	√	√
	506	2010 2020 2030 2040	2050 2060 FXI	5.0	3.2	$4.0 \leq D < 7.0$	√	√
	507	2010 2020 2030 2040	2050 2060 FXI	8.5	5.0	$7.0 \leq D < 10.0$	√	√
	508	2010 2020 2030 2040	2050 2060 FXI	9.5	8.0	$10.0 \leq D$	√	√

### 3 CUSTOMIZED NOZZLES

#### 3.1 Slot Nozzles



##### 3.1.1 700 Models

Nozzle	Type	Machine model	Slot Width - W (mm)	Slot Length - L (mm)	Applicable component Width	Vision	Laser
	67	750 760	1.0	8.0	> 1.0	NA	√
	7	750 760	1.0	9.0	> 1.0	NA	√
	5	750 760	1.6	9.0	> 1.6	NA	√
	27	750 760	0.8	6.0	> 0.8	NA	√
	21	760	3.1	9.0	> 3.1	√	NA
	69	760	1.6	6.0	> 1.6	√	NA
	84	760	1.0	9.0	> 1.0	√	NA
	66	760	6.0	8.0	> 6.0	√	NA

	63	760	1.2	6.0	> 1.2	√	NA
---	----	-----	-----	-----	-------	---	----

### 3.1.2 2000 Models

Nozzle Type	Machine model		Slot Width - - W (mm)	Slot Length - L (mm)	Applicable component Width	Vision	Laser
512	2010 2020 2030 2040	2050 2060 FXI	1.6	9.0	> 1.6	√	√
513	2010 2020 2030 2040	2050 2060 FXI	1.2	6.0	> 1.2	√	√
514	2010 2020 2030 2040	2050 2060 FXI	1.2	9.0	> 1.2	√	√
515	2010 2020 2030 2040	2050 2060 FXI	1.0	4.0	> 1.0	√	√
516	2010 2020 2030 2040	2050 2060 FXI	0.9	9.0	> 0.9	√	√
517	2010 2020 2030 2040	2050 2060 FXI	3.4	9.0	> 3.4	√	√
518	2010 2020 2030 2040	2050 2060 FXI	2.2	9.0	> 2.2	√	√
519	2010 2020 2030 2040	2050 2060 FXI	3.3	9.0	> 3.3	√	√



520	2010 2020 2030 2040	2050 2060 FXI	1.6	6.0	> 1.6	√	√
521	2010 2020 2030 2040	2050 2060 FXI	0.8	6.0	> 0.8	√	√
522	2010 2020 2030 2040	2050 2060 FXI	1.0	9.0	> 1.0	√	√
523	2010 2020 2030 2040	2050 2060 FXI	1.2	8.0	> 1.2	√	√
524	2010 2020 2030 2040	2050 2060 FXI	1.0	7.0	> 1.0	√	√
527	2010 2020 2030 2040	2050 2060 FXI	1.0	3.0	> 1.0	√	√
529	2010 2020 2030 2040	2050 2060 FXI	0.9	2.0	> 0.9	√	√
530	2010 2020 2030 2040	2050 2060 FXI	0.9	4.0	> 0.9	√	√
531	2010 2020 2030 2040	2050 2060 FXI	1.0	6.0	> 1.0	√	√

### 3.2 Gripper Nozzles



#### 3.2.1 700 Models

Nozzle Type	Machine model	Arm Width- W (mm)	Arm Height- H (mm)	Applicable component Width	Vision	Laser
GA53	750 760	5.0	3.5	0.8 to 2.2	√	√
GA52	750 760	5.0	2.5	0.8 to 2.2	√	√
GA55	750 760	5.0	5.0	0.8 to 2.2	√	√
GA43	750 760	4.0	3.5	0.8 to 2.2	√	√
GA42	750 760	4.0	2.5	0.8 to 2.2	√	√
GA45	750 760	4.0	5.0	0.8 to 2.2	√	√
GB53	750 760	5.0	3.5	1.8 to 3.2	√	√
GB52	750 760	5.0	2.5	1.8 to 3.2	√	√
GB55	750 760	5.0	5.0	1.8 to 2.2	√	√
GB43	750 760	4.0	3.5	1.8 to 2.2	√	√
GB42	750 760	4.0	2.5	1.8 to 2.2	√	√
GB45	750 760	4.0	5.0	1.8 to 2.2	√	√
GC53	750 760	5.0	3.5	2.8 to 4.2	√	√
GC52	750 760	5.0	2.5	2.8 to 4.2	√	√
GC55	750 760	5.0	5.0	2.8 to 4.2	√	√

GC43	750 760	4.0	3.5	2.8 to 4.2	√	√
GC42	750 760	4.0	2.5	2.8 to 4.2	√	√
GC45	750 760	4.0	5.0	2.8 to 4.2	√	√
GD53	750 760	5.0	3.5	3.8 to 5.2	√	√
GD52	750 760	5.0	2.5	3.8 to 5.2	√	√
GD55	750 760	5.0	5.0	3.8 to 5.2	√	√
GD43	750 760	4.0	3.5	3.8 to 5.2	√	√
GD42	750 760	4.0	2.5	3.8 to 5.2	√	√
GD45	750 760	4.0	5.0	3.8 to 5.0	√	√
GE53	750 760	5.0	3.5	4.8 to 6.2	√	√
GE52	750 760	5.0	2.5	4.8 to 6.2	√	√
GE55	750 760	5.0	5.0	4.8 to 6.2	√	√
GE43	750 760	4.0	3.5	4.8 to 6.2	√	√
GE42	750 760	4.0	2.5	4.8 to 6.2	√	√
GE45	750 760	4.0	5.0	4.8 to 6.2	√	√

### 3.2.2 2000 Models

Nozzle Type	Machine model		Arm Width-W (mm)	Arm Height-H (mm)	Applicable component Width	Vision	Laser
800	2010 2020 2030 2040	2050 2060 FXI	2.8	3.5	0.8 to 2.2	√	√
801	2010 2020 2030 2040	2050 2060 FXI	3.8	3.5	1.8 to 3.2	√	√
802	2010 2020 2030 2040	2050 2060 FXI	4.8	3.5	2.8 to 4.2	√	√
803	2010 2020 2030 2040	2050 2060 FXI	5.8	3.5	3.8 to 4.2	√	√

### 3.3 Pipe Nozzles

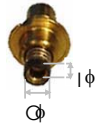













#### 3.3.1 700 Models











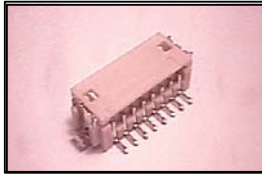



Nozzle	Type	Machine model	Tip Outer $\phi$ (mm)	Tip Inner $\phi$ (mm)	Applicable component Width	Vision	Laser
	56	750 760	4.2	3.3	> 4.2	NA	√
	58	750 760	1.5	1.0	> 1.5	√	√
	47	750 760	7.0	4.2	> 7.0	NA	√
	46	750 760	6.5	4.0	> 6.5	NA	√

### 3.3.2 2000 Models



Nozzle Type	Machine model		Tip Outer $\phi$ (mm)	Tip Inner $\phi$ (mm)	Applicable component Width	Vision	Laser
525	2010 2020 2030 2040	2050 2060 FXI	3.0	1.5	> 3.0	√	√
526	2010 2020 2030 2040	2050 2060 FXI	3.5	1.5	> 3.5	√	√
528	2010 2020 2030 2040	2050 2060 FXI	2.0	0.7	> 2.0	√	√

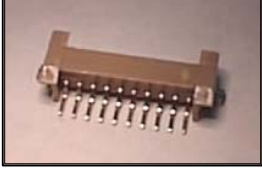





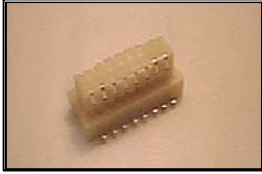





#### 4 SPECIAL APPLICATIONS

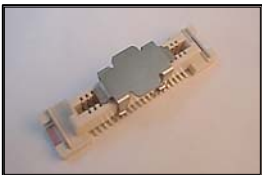

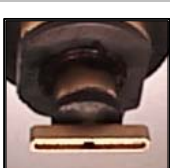

Component Type	Dimensions (mm)	Component Supply	Machine Model	Vision Centering	Laser Centering	Nozzle Type
 <p>Hirose PWB-FPC</p>	<p>W = 6.4 L = 20.6 T = 2.0 P = 1.0</p>	32 mm Emboss	740 760	√		 <p>Type 14</p>
 <p>Hirose PWB-FPC</p>	<p>W = 7.0 L = 16.5 T = 2.0 P = 0.5</p>	32 mm Emboss	740 760	√		 <p>Type 14</p>
 <p>Hirose PWB-FPC</p>	<p>W = 6.4 L = 9.1 T = 2.0 P = 0.5</p>	16 mm Emboss	760	√		 <p>Type 23</p>
 <p>Molex PWB-FPC</p>	<p>W = 3.5 L = 25.7 T = 3.9 P = 1.0</p>	44 mm Emboss	760		√	 <p>Type 5</p>
 <p>Molex PWB-FPC</p>	<p>W = 3.6 L = 23.7 T = 4.7 P = 1.25</p>	44 mm Emboss	750		√	 <p>Type 53</p>
 <p>AMP PWB-IPC</p>	<p>W = 10.4 L = 15.4 T = 5.8 P = 2.0</p>	24 mm Emboss	730 750		√	 <p>Type 104</p>

	W = 6.5 L = 14.65 T = 3.6 P = 1.25	Stick Type I	740 760	√		
Hirose PWB-FPC						Type 23
	W = 6.7 L = 42.45 T = 2.5 P = 1.25	Stick Type I	760	√		
Hirose PWB-FPC						Type 14
	W = 6.7 L = 42.45 T = 2.5 P = 1.25	16 mm Emboss	730 750		√	
Hirose PWB-FPC						Type 14
	W = 4.9 L = 23.4 T = 4.8 P = 1.25	44 mm Emboss	760	√		
Hirose PWB-FPC						Type 14
	W = 4.2 L = 23.9 T = 4.7 P = 1.25	44 mm Emboss	760	√		
Molex PWB-FPC						Type 64
	W = 5.2 L = 23.9 T = 3.4 P = 1.25	44 mm Emboss	760	√		
Molex PWB-FPC						Type 14
	W = 7.25 L = 17.65 T = 3.45 P = 1.25	32 mm Emboss	730 750		√	
Japan Aviation Electronics						Type 5

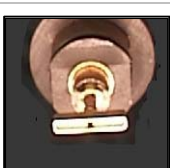

	W = 4.3 L = 7.0 T = 4.25 P = 0.8	16 mm Emboss	740 760	√		
AMP PWB-IPC						Type 34
	W = 4.3 L = 7.8 T = 3.75 P = 0.8	16 mm Emboss	760	√		
AMP PWB-IPC						Type 34
	W = 4.4 L = 13.95 T = 3.6 P = 2.5	24 mm Emboss	730 750		√	
AMP PWB-IPC						Type 5
	W = 5.9 L = 7.7 T = 4.65 P = 1.25	16 mm Emboss	730 750		√	
AMP PWB-IPC						Type 104
	W = 5.6 L = 5.2 T = 3.5 P = 1.25	16 mm Emboss	730 750		√	
AMP PWB-IPC						Type 103
	W = 5.6 L = 20.2 T = 3.5 P = 1.25	32 mm Emboss	730 750		√	
AMP PWB-IPC						Type 103
	W = 5.9 L = 16.45 T = 4.65 P = 1.25	24 mm Emboss	730 750		√	
AMP PWB-IPC						Type 104

	W = 6.8 L = 42.0 T = 8.6 P = 0.8	56 mm Emboss	760	√		
AMP PWB-IPC						Type 202
	W = 6.4 L = 42.0 T = 5.6 P = 0.8	56 mm Emboss	760	√		
AMP PWB-IPC						Type 202
	W = 6.4 L = 26.0 T = 5.5 P = 0.8	44 mm Emboss	760		√	
AMP PWB-IPC						Type 105
	W = 4.3 L = 18.2 T = 3.75 P = 0.8	24 mm Emboss	750		√	
AMP PWB-IPC						Type 38
	W = 4.6 L = 8.0 T = 2.7 P = 0.5	16 mm Emboss	760	√		
AMP PWB-IPC						Type 23
	W = 4.6 L = 17.1 T = 2.2 P = 0.5	32 mm Emboss	760	√		
Hirose PWB-FPC						Type 14
	W = 4.6 L = 14.7 T = 4.3 P = 0.5	24 mm Emboss	760	√		
Hirose PWB-FPC						Type 45

	<p>W = 5.5 L = 20.3 T = 4.4 P = 1.0</p>	<p>32 mm Emboss</p>	<p>730 750</p>	<p>√</p>			<p>Type 5</p>
	<p>W = 7.2 L = 19.5 T = 4.55 P = 0.8</p>	<p>32 mm Emboss</p>	<p>760</p>	<p>√</p>			<p>Type 64</p>

## 5 QUICK REFERENCE TABLE

### 5.1 Standard Nozzles

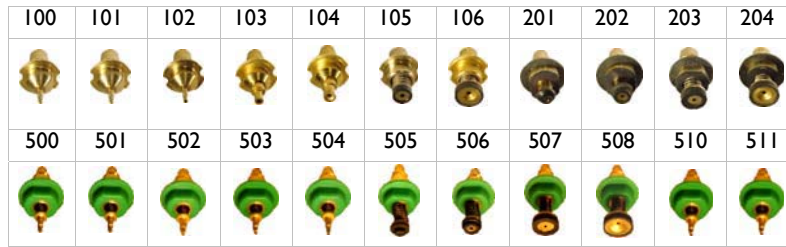

No	Standard Nozzle Configuration						
	FXI	2050	2060	2010	2020	2030	2040
500	8*√	4*√	5*√		5*√		
501							
502				4*√		8*√	2*√
503				4*√		8*√	2*√
504	8*√	4*√	5*√		5*√		
505	2*√	2*√	2*√	1*√	2*√		2*√
506	2*√	2*√	2*√	1*√	2*√		2*√
507		2*√	2*√	1*√	2*√		2*√
508	2*√	1*√	1*√	1*√	1*√	1*√	2*√
510							
511							

The first version of 500 series type nozzles were developed for KE-2000 conventional models (KE-2010, 2020, 2030 & 2040 machines).

JUKI have now released a new revision of 500 type nozzles with the machine models KE-2050, KE-2060 & FX-I.

Machine models																				
	500	501	502	503	504	505	506	507	508	500	501	502	503	504	505	506	507	508		
KE-2010	√	√	√	√	√	√	√	√	√	X	X	X	X	X	X	X	X	X		
KE-2020	√	√	√	√	√	√	√	√	√	X	X	X	X	X	X	X	X	X		
KE-2030	√	√	√	√	√	√	√	√	√	X	X	X	X	X	X	X	X	X		
KE-2040	√	√	√	√	√	√	√	√	√	X	X	X	X	X	X	X	X	X		
KE-2050	√	√	√	√	√	√	√	√	√	√	√	√	√	√	√	√	√	√		
KE-2060	√	√	√	√	√	√	√	√	√	√	√	√	√	√	√	√	√	√		
FXI	√	√	√	√	√	√	√	√	√	√	√	√	√	√	√	√	√	√		

√ = Compatible, X = Non-Compatible

Nozzle #	Part #	Part #
500	E36087290A0	40011046
501	E36007290A0	40001339
502	E36017290A0	40001340
503	E36027290A0	40001341
504	E36037290A0	40001342
505	E36047290A0	40001343
506	E36057290A0	40001344
507	E36067290A0	40001345
508	E36077290A0	40001346

## 5.2 Gripper Nozzles

700 Models	Applicable component (mm)
Gripper Nozzle GA53.5	0.8 TO 2.2
Gripper Nozzle GA52.5	0.8 TO 2.2
Gripper Nozzle GA55.0	0.8 TO 2.2
Gripper Nozzle GA43.5	0.8 TO 2.2
Gripper Nozzle GA42.5	0.8 TO 2.2
Gripper Nozzle GA45.0	0.8 TO 2.2
Gripper Nozzle GB53.5	1.8 TO 2.2
Gripper Nozzle GB52.5	1.8 TO 2.2
Gripper Nozzle GB55.0	1.8 TO 2.2
Gripper Nozzle GB43.5	1.8 TO 2.2
Gripper Nozzle GB42.5	1.8 TO 2.2
Gripper Nozzle GB45.0	1.8 TO 2.2
Gripper Nozzle GC53.5	2.8 TO 4.2
Gripper Nozzle GC52.5	2.8 TO 4.2
Gripper Nozzle GC55.0	2.8 TO 4.2
Gripper Nozzle GC43.5	2.8 TO 4.2
Gripper Nozzle GC42.5	2.8 TO 4.2
Gripper Nozzle GC45.0	2.8 TO 4.2
Gripper Nozzle GD53.5	3.8 TO 5.2
Gripper Nozzle GD52.5	3.8 TO 5.2
Gripper Nozzle GD55.0	3.8 TO 5.2
Gripper Nozzle GD43.5	3.8 TO 5.2
Gripper Nozzle GD42.5	3.8 TO 5.2
Gripper Nozzle GD45.0	3.8 TO 5.2
Gripper Nozzle GE53.5	4.8 TO 6.2
Gripper Nozzle GE52.5	4.8 TO 6.2
Gripper Nozzle GE55.0	4.8 TO 6.2
Gripper Nozzle GE43.5	4.8 TO 6.2
Gripper Nozzle GE42.5	4.8 TO 6.2
Gripper Nozzle GE45.0	4.8 TO 6.2

2000/ FXI Models	Part Number	Applicable component (mm)
Gripper Nozzle Type 800	E36237210A0	0.8 TO 2.2
Gripper Nozzle Type 801	E36247210A0	1.8 TO 3.2
Gripper Nozzle Type 802	E36257210A0	2.8 TO 4.2
Gripper Nozzle Type 803	E36267210A0	3.8 TO 5.2





Marketing Communications  
19-May-04  
Nozzle Catalogue  
Release Date: 25-May-04  
Version: c  
25/04/100/EU

**Juki Automation Systems AG**

Weissensteinstrasse 81  
CH-4500 Solothurn  
Phone +41 (0) 32 626 29 29  
Fax +41 (0) 32 626 29 30

**Juki Automation Systems GmbH**

Steinfeldstrasse 1  
DE-90425 Nürnberg  
Phone +49 911 93 62 660  
Fax +49 911 93 62 66 26

**Juki Automation Systems Ltd.**

Leeds House, Amberly Court,  
Whitworth Road, Crawley  
UK-West Sussex, RH11 7XL  
Phone +44 (0) 1293 55 49 00  
Fax +44 (0) 1293 55 49 01

**Juki Automation Systems Inc.**

507 Airport Boulevard  
Morrisville, NC 27560 USA  
Phone +1 (919) 460 0111  
Fax +1 (919) 469 0480

**Juki Corporation**

8-2-1 Kokuryo-cho  
Chofu-shi, Tokyo 182-8655, Japan  
Phone +81 3 3480 3330  
Fax +81 3 3488 1971

E-mail: [marketing@jas-smt.com](mailto:marketing@jas-smt.com)  
[www.jas-smt.com](http://www.jas-smt.com)

**JUKI**  
AUTOMATION SYSTEMS