

**SEGA**

# Service Manual

## TV TUNER PACK (PAL) FOR GAME GEAR

MK-2101-05

MK-2101-~~22~~-18

MK-2101-20

*TFL*  
MK-2101-18 2730

### GENERAL SPECIFICATIONS

- MK-2101-05 : I (PAL): England
- MK-2101-18 : B/G (PAL): Germany
- MK-2101-20 : B/G (PAL): General Europe
- Receiving Channels VHF 1 – 12 ch  
UHF 21 – 69 ch
- Operating Temperature Range +5°C – +40°C  
+41°F – +104°F
- Storage Temperature Range –20°C – +60°C  
–4°F – +140°F
- Dimensions 107.2 (H) × 120 (W) × 39 (D) mm
- Weight 140 gr (w/o batteries)

Note: Specifications and design are subject to change without notice.

# CONTENTS

SPECIFICATIONS.....	1
CONTENTS.....	3
DISASSEMBLY AND ASSEMBLY PROCEDURE.....	4
BLOCK DIAGRAM.....	6
ADJUST AND ALIGNMENT .....	7
GENERAL DESCRIPTION.....	7
1. SYSTEM VOLTAGE INSPECTION (PCB-2) .....	8
2. VIDEO IF ALIGNMENT AND AFT ALIGNMENT (PCB-2) .....	9
3. RF AGC DELAY ALIGNMENT (PCB-2) .....	10
4. TUNING DIAL CALIBRATION (PCB-2) .....	11
5. GRADATION ALIGNMENT AND BRIGHTNESS ALIGNMENT (PCB-1) .....	12
6. PLL ALIGNMENT (PCB-1) .....	13
7. RGB PHASE ALIGNMENT .....	14
TROUBLE SHOOTING CHART .....	15
PCB (TOP AND BOTTOM VIEWS) .....	23
ELECTRICAL PARTS LIST .....	31
EXPLODED VIEW PARTS LIST .....	36
EXPLODED VIEW.....	37
SCHEMATIC DIAGRAM.....	39

# DISASSEMBLY AND ASSEMBLY PROCEDURE

## Disassembly

<Fig. 1>

- Set the unit with its channel plate downward.
- Remove the screw (503) and the Spring Lock Washer (505) at the back face of unit.
- Hold the side of the unit and pull out the Antenna (ANT201) in the direction indicated by the arrow A.
- Remove the four screws (501) and the two screws (502) at the back face of unit.  
The special screwdriver (for LH2) is necessary to remove these screws (502).

<Fig. 2>

- Remove the Bottom Case (200).

<Fig. 3>

- Remove the Band Select Knob (101) in the direction indicated by the arrow B.

<Fig. 4>

- Hold the hook of the Color Adjust Knob (102) by a Tweezers. And push the hook in the direction indicated by the arrow C. And remove the Color Adjust Knob (102) from the Top Case (100).

<Fig. 5>

- Remove the PCB1 and the PCB2 from the Top Case (100).
- Hold the FFC (Flexible Flat Cable) and gently pull out the FFC in the direction indicated by the arrow D, to remove it from the Connector (K401) on the PCB2.

<Fig. 6>

- Remove the screw (504) at the back face of the PCB2 and pull out the Channel Indicator Ass'y (400) in the direction indicated by the arrow E.

## Assembly

- Perform assembly by reversing the procedure outlined for disassembly.
- Caution  
Don't forget to install the Band Select Knob (101) correctly in relation to the Channel Indicator Ass'y (400).  
Don't forget to install the Color Adjust Knob (102) into the Top Case (100), and joint it into the Tint Potentiometer (VR401).

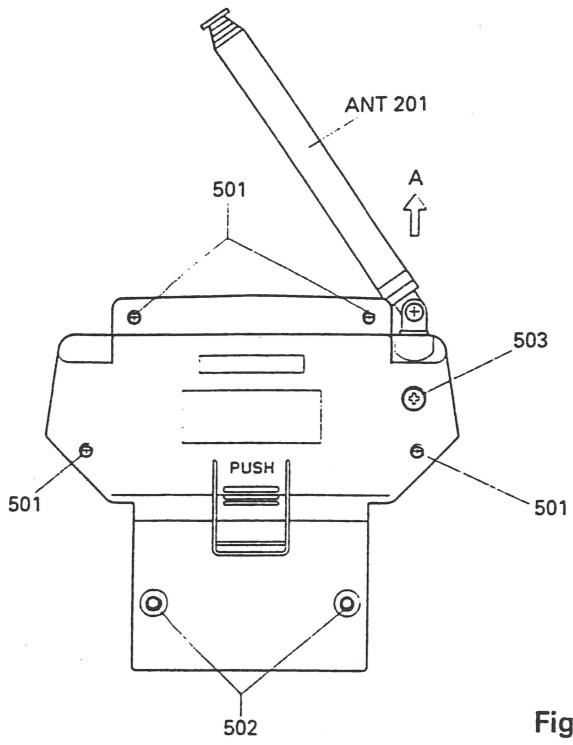

Fig. 1

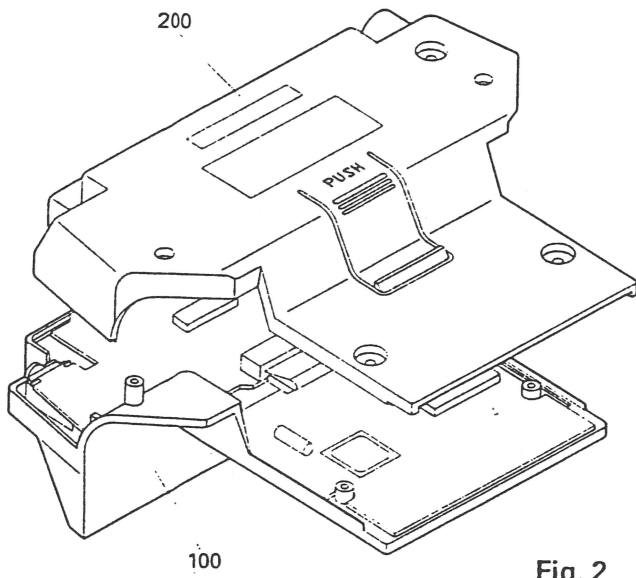

Fig. 2

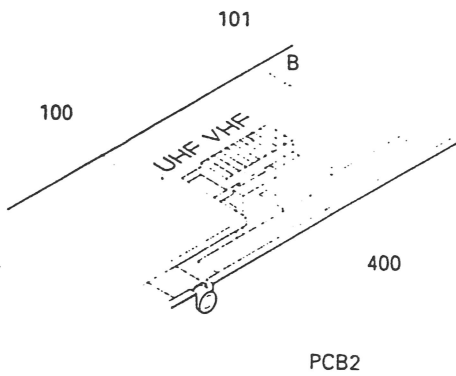

Fig. 3

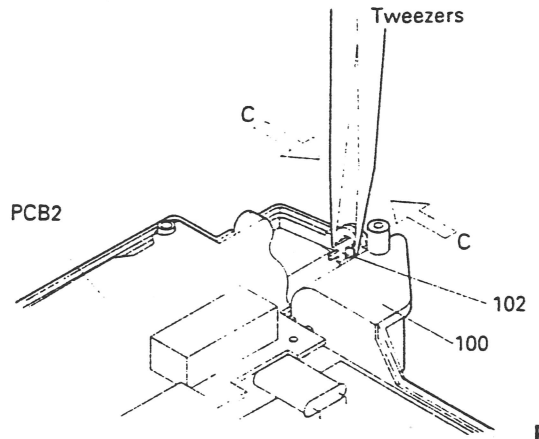

Fig. 4

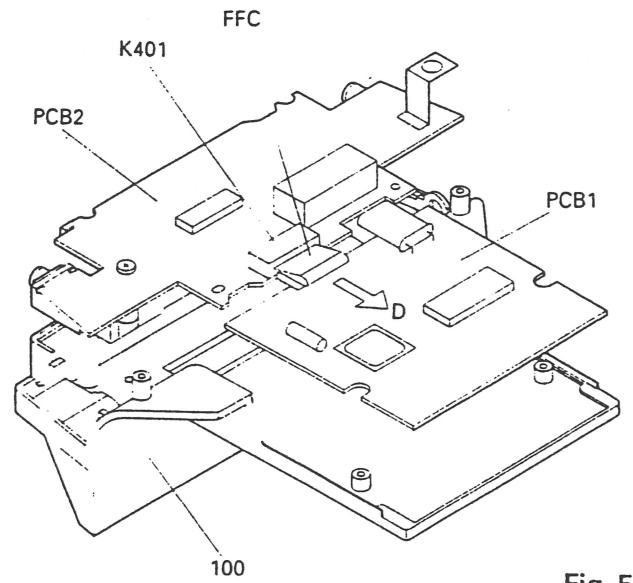

Fig. 5

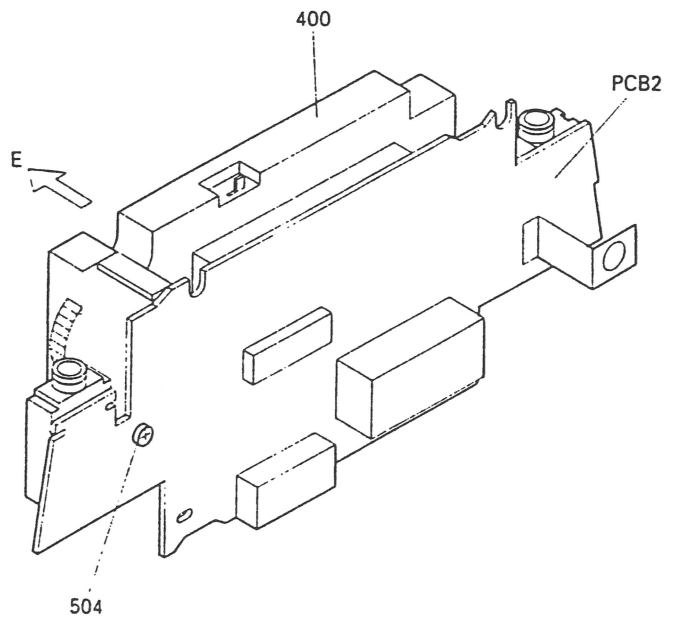

Fig. 6

# BLOCK DIAGRAM

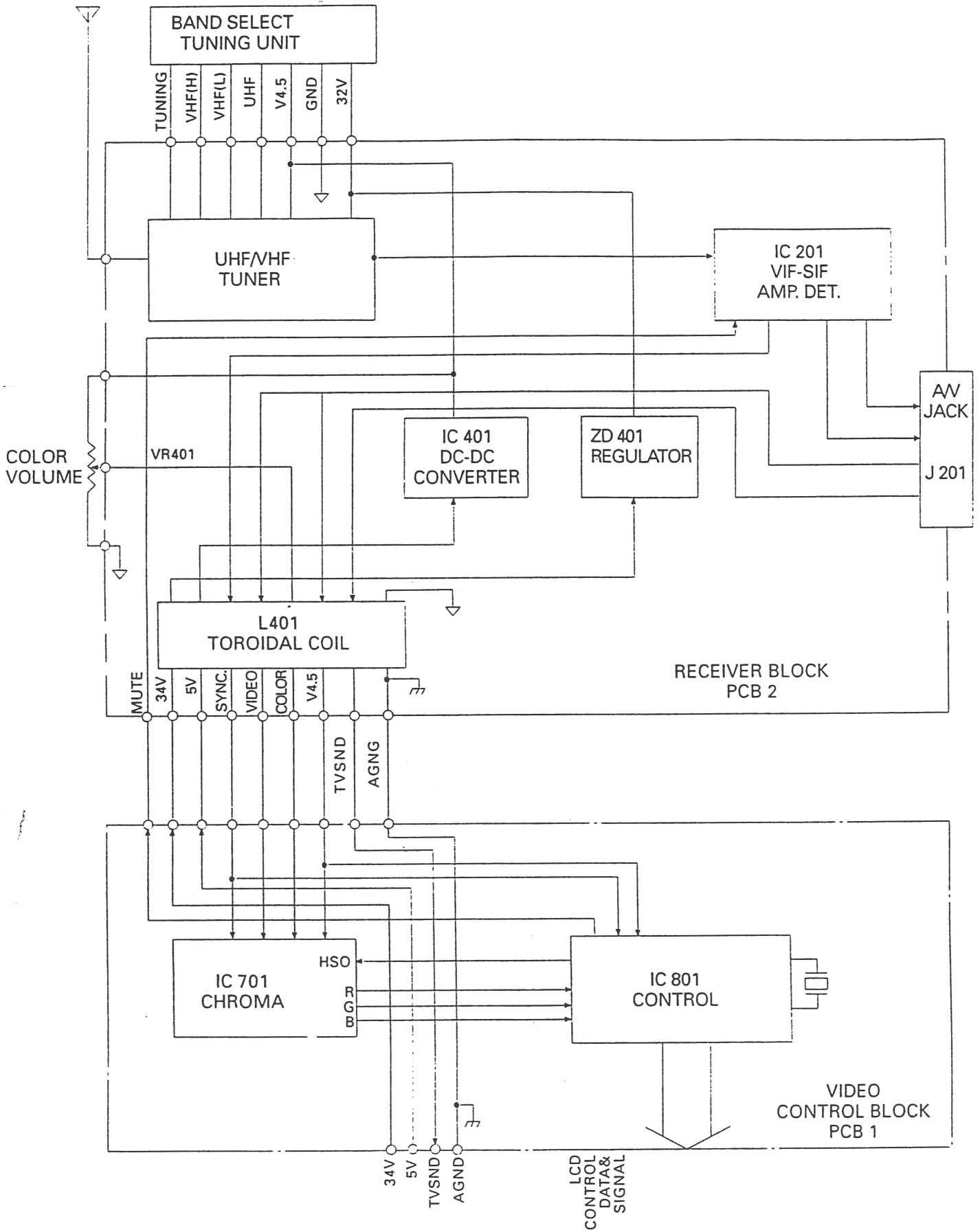

Fig. 7

# ADJUSTMENT AND ALIGNMENT

## GENERAL DESCRIPTION

The adjustments and alignments outlined here are only required after the components listed below are replaced in particular parts.

The following adjustments are required:

*We possess*

No.	ITEM	PCB	ADJUSTMENT	REMARKS	MEASURING INSTRUMENT
1	Video IF Alignment And AFT Alignment	PCB-2	L202 L201	668	<ul style="list-style-type: none"> <li>Sweep Marker Generator</li> <li>Alignment Scope</li> </ul>
2	RF AGC Delay Alignment	PCB-2	VR201 VR202	667	<ul style="list-style-type: none"> <li>Color Pattern Generator</li> <li>AM, FM Signal Generator</li> <li>Channel Signal Generator</li> <li>DC Voltmeter</li> <li>Oscilloscope</li> </ul>
3	Tuning Dial Calibration	PCB-2	VR1 VR2 VR3 VR4		<ul style="list-style-type: none"> <li>Color Pattern Generator</li> <li>AM, FM Signal Generator</li> <li>Channel Signal Generator</li> <li>Oscilloscope</li> </ul>
4	Gradation Alignment	PCB-1	VR801 VR802		<ul style="list-style-type: none"> <li>Pattern Generator</li> </ul>
5	RGB Phase Alignment	PCB-1	TC701		<ul style="list-style-type: none"> <li>Color Pattern Generator</li> <li>Oscilloscope</li> </ul>
6	PLL Alignment	PCB-1	TC801		<ul style="list-style-type: none"> <li>Color Pattern Generator</li> <li>Oscilloscope</li> </ul>

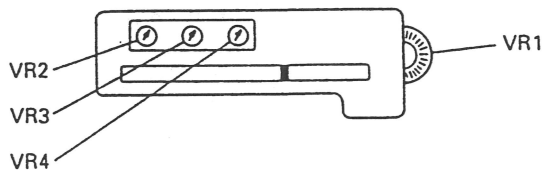

Fig. 8

## 1. SYSTEM VOLTAGE INSPECTION (PCB-2)

- 1 Connect an I/O TERMINAL (K401) to 5.0 V and 34.0 V DC external power supply.
- 2 Set the power switch to ON.
- 3 • Output voltage 4.5 V DC  $\pm$  0.2 V at TP401?  
• Output voltage 32.0 V DC  $\pm$  1.0 V at TP404?

## 2. VIDEO IF ALIGNMENT AND AFT ALIGNMENT (PCB-2)

- 1 Set the tuning wheel to the lowest unused VHF.
- 2 Set the marker of Alignment Scope. e: 38.9 MHz
- 3 Set the switch of Sweep Marker Generator to the AC.
- 4 Remove the solder bridge SR101, 201.
- 5 Connect a DC power supply (+5.0 V) between TP405 and TP402.
- 6 Connect a DC power supply (+34 V) to TP406.
- 7 Connect a DC power supply (+3.5 V) to TP205.
- 8 Connect a 0.01  $\mu\text{F}$  capacitor between TP204 and the OUT terminal of Sweep Marker Generator.
- 9 Connect TP207 to the IN terminal of Sweep Marker Generator.
- 10 VIF ALIGNMENT (See table)
- 11 Connect the GND to TP205.
- 12 Connect TP202 to the OUT terminal of Sweep Marker Generator.
- 13 Connect TP107 to the IN terminal of Sweep Marker Generator.
- 14 AFT ALIGNMENT (See table)

Input Connection	Input Point	Input Signal	Step	Adjust	Output Connection	Output Point	Adjust For
• Sweep Marker Generator	TP204	IF: 38.9 MHz 70 dB $\mu$	1 VIF	L202	• Sweep Marker Generator • Alignment Scope	TP207	Adjust L202 to obtain a suitable size curve on the alignment scope as shown in Fig. 10
	TP202	IF: 38.9 MHz 70 dB $\mu$	2 AFT	L201		TP107	Adjust L201 for setting the marker (d) between the peak (a) on positive and the peak (b) on negative as shown in Fig. 11

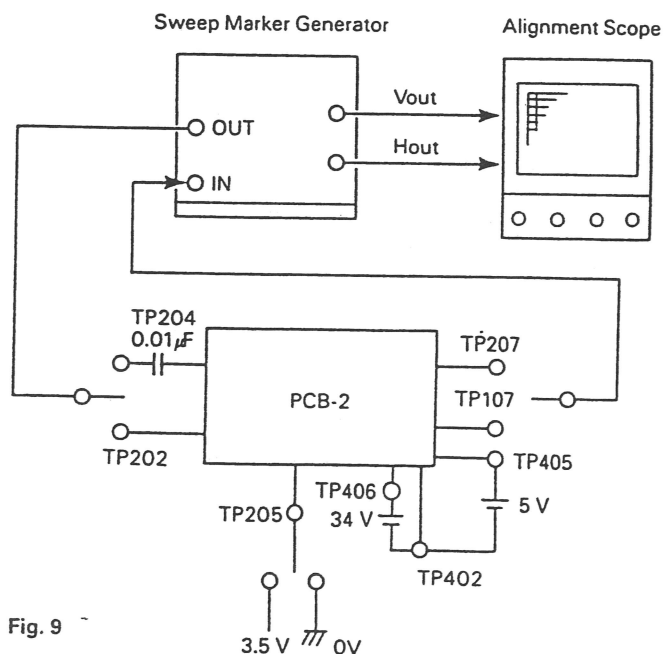

Fig. 9

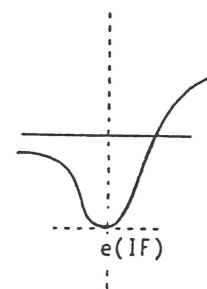

Fig. 10

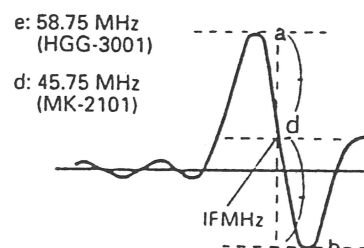

Fig. 11



### 3. RF AGC DELAY ALIGNMENT (PCB-2)

- 1 Short the solder bridge SR 101.  
Short the solder bridge SR 201.
- 2 Remove the solder bridge SR 102.
- 3 Connect a DC power supply (+ 5.0 V) between TP405 and TP402.
- 4 Connect a DC power supply (+34.0 V) to TP406.
- 5 Set the video signal of Color Pattern Generator to white 75%.
- 6 Turn the channel to CH21.

Input Connection	Input Point	Input Signal	Step	Adjust	Output Connection	Output Point	Adjust For
<ul style="list-style-type: none"> <li>• Color Pattern Generator</li> <li>• AM-FM Signal Generator</li> <li>• Channel Signal Generator</li> </ul>	TP102	<ul style="list-style-type: none"> <li>• Color Bar</li> <li>• SIF FM RF Frequency 5.5 MHz</li> </ul>	1	VR202 See PCB-2 Top View	Oscilloscope	TP207	Adjust VR202 to obtain a suitable size wave on the oscilloscope as shown in Fig. 13-a
			2	VR201 See PCB-2 Top View			Adjust VR201 until the minimum noise is obtained at the point (a) and not to break the horizontal synchronizing signal. Fig. 13-b
		<ul style="list-style-type: none"> <li>Frequency Deviation 50 kHz, Tone Signal 1 kHz, Output 90 dB<math>\mu</math></li> <li>• Channel Signal: 471.25 MHz 70 dB<math>\mu</math></li> </ul>					

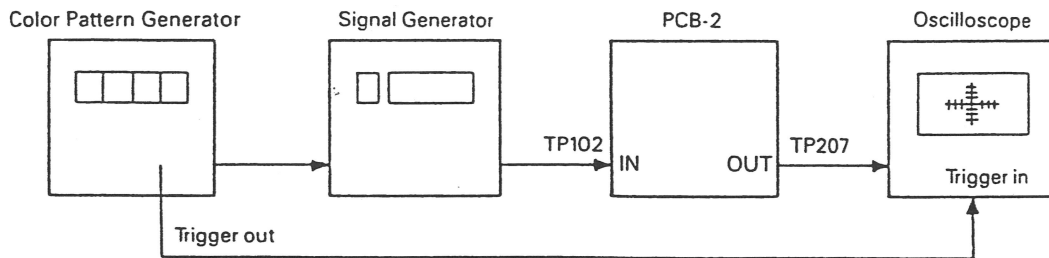

Fig. 12



Fig. 13-a

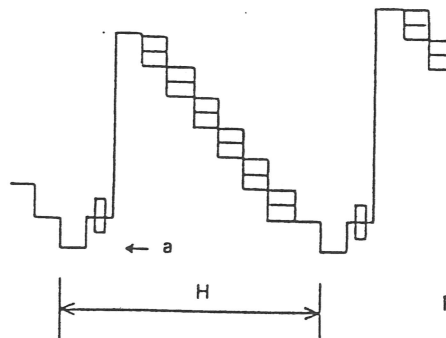

Fig. 13-b

#### 4. TUNING DIAL CALIBRATION (PCB-2)

- 1 Short the solder bridge SR 101 and SR 201.
- 2 Connect a DC power supply (+ 5.0 V) between TP405 and TP402.
- 3 Connect a DC power supply (+34.0 V) to TP406.
- 4 Input the standard TV RF signal to TP102

Input Equipment	Input Point	Input Signal	Step	Adjust	Output Connection	Output Point	Adjust For	
<ul style="list-style-type: none"> <li>• Color Pattern Generator</li> <li>• Signal Generator</li> </ul>	TP102	Set the band select switch to VHF and tune the Channel to CH C						
		82.25 MHz 70 dB $\mu$	1	VR2 ( See PCB-2 Top View )		TV	Adjust to the TV screen becomes a clear.	
		Tune the Channel to CH 12						
		224.25 MHz 70 dB $\mu$	2	VR3 ( See PCB-2 Top View )		TV	Adjust to the TV screen becomes a clear.	
		Check channel C. If the TV screen not became clear picture, try again Step. 1, 2.						
TP102	Set the band select switch to UHF and tune the Channel to CH 69							
	855.25 MHz 70 dB $\mu$	3	VR4 ( See PCB-2 Top View )		TV	Adjust to the TV screen becomes a clear.		
	Check channel 21 If the TV screen not became clear picture, try again Step. 3, 4.							

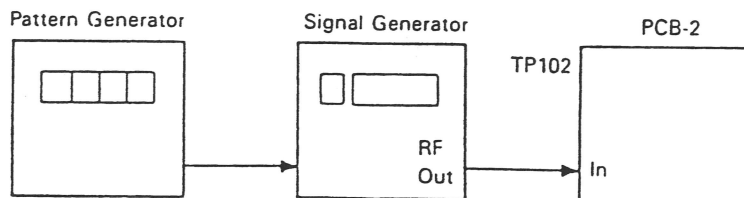

Fig. 14

## 5. GRADATION ALIGNMENT AND BRIGHTNESS ALIGNMENT (PCB-1)

- 1 Connect PCB-2 by FFC.
- 2 Input DC power supply (+9.0 V) to power Jack of G & G.
- 3 Input Video Signal to AV Jack (J201) of PCB-2.
- 4 Adjust the bright volum of G & G to obtain the suitable brightness.

Input Equipment	Input Point	Input Signal	Step	Adjust	Output Connection	Output Point	Adjust For
• Color Pattern Generator	J201 AV Jack (PCB-2)	Luminance (Fig. 16)	1	VR701  VR702	G & G Display		Adjust VR701 and VR702 as shown in Fig. 17. MK-2101

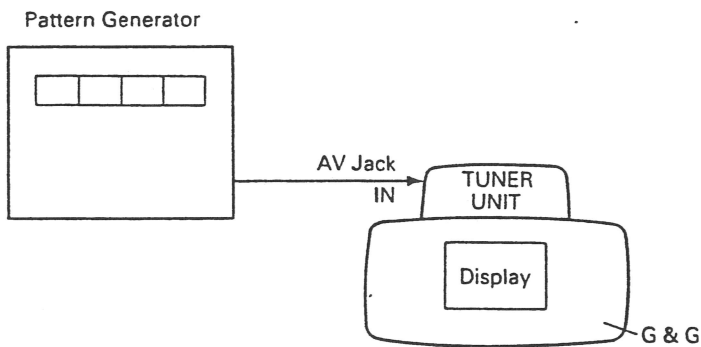

Fig. 15

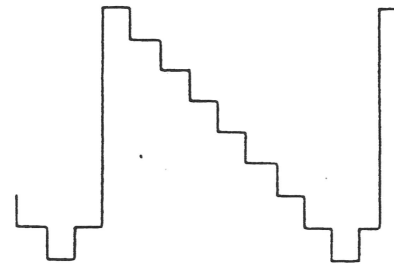

Fig. 16

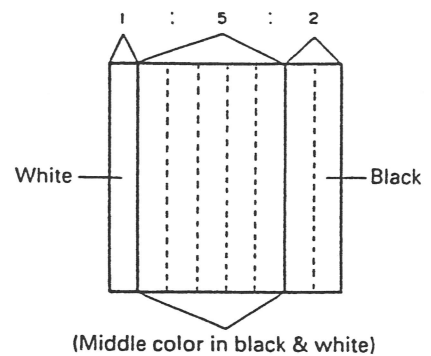

Fig. 17

## 6. PLL ALIGNMENT (PCB-1)

- 1 Connect PCB-2 by FFC.
- 2 Input DC power supply (+9.0 V) to Power Jack of G & G.
- 3 Input Video signal to AV Jack of J201.

Input Equipment	Input Point	Input Signal	Step	Adjust	Output Connection	Output Point	Adjust For
• Color Pattern Generator	J201 AV Jack (PCB-2)	Color Bar	1	TC801 (See PCB-1 Top View)	Oscilloscope	TP825 (See PCB-1 Top View)	Adjust TC801 as shown in Fig. 19.

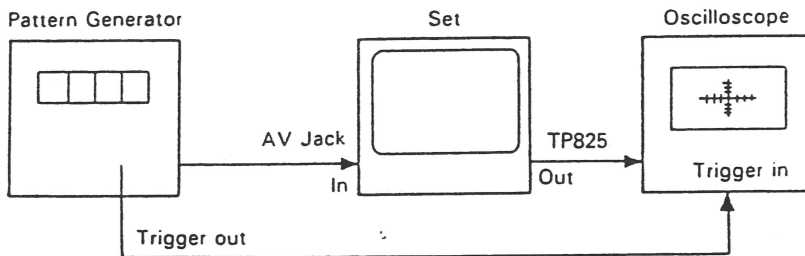

Fig. 18

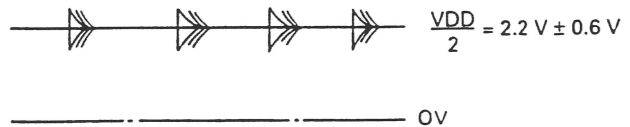

Fig. 19

## 7. RGB PHASE ALIGNMENT

- 1 Connect a PCB-2 by FFC.
- 2 Input DC power supply (+9.0 V) to Power Jack of G & G.
- 3 Adjust bright volum of G & G to obtain the suitable brightness.
- 4 Input Video Signal to AV Jack of J201.

Input Equipment	Input Point	Input Signal	Step	Adjust	Output Connection	Output Point	Adjust For
• Color Pattern Generator	J201 AV Jack (PCB-2)	Color Bar	1	CT701 See PCB-1	Oscilloscope	TP825 See PCB-1	Adjust CT701 as shown in Fig. 21. Voltage (a) equal to Voltage (b).

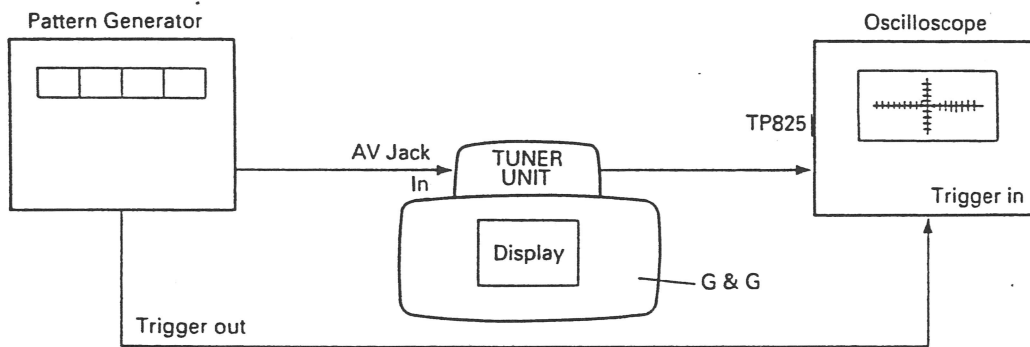

Fig. 20

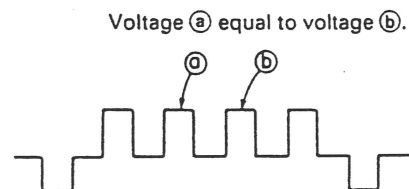

Fig. 21

# TROUBLE SHOOTING CHART

## 1. POOR PICTURE OR NO PICTURE

- Supply 9.0 V DC at Power jack of G & G
- Connect external antenna to TV ANT.
- Tune a channel for TV.

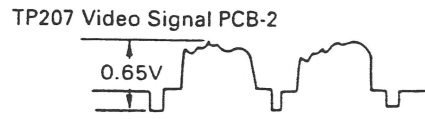
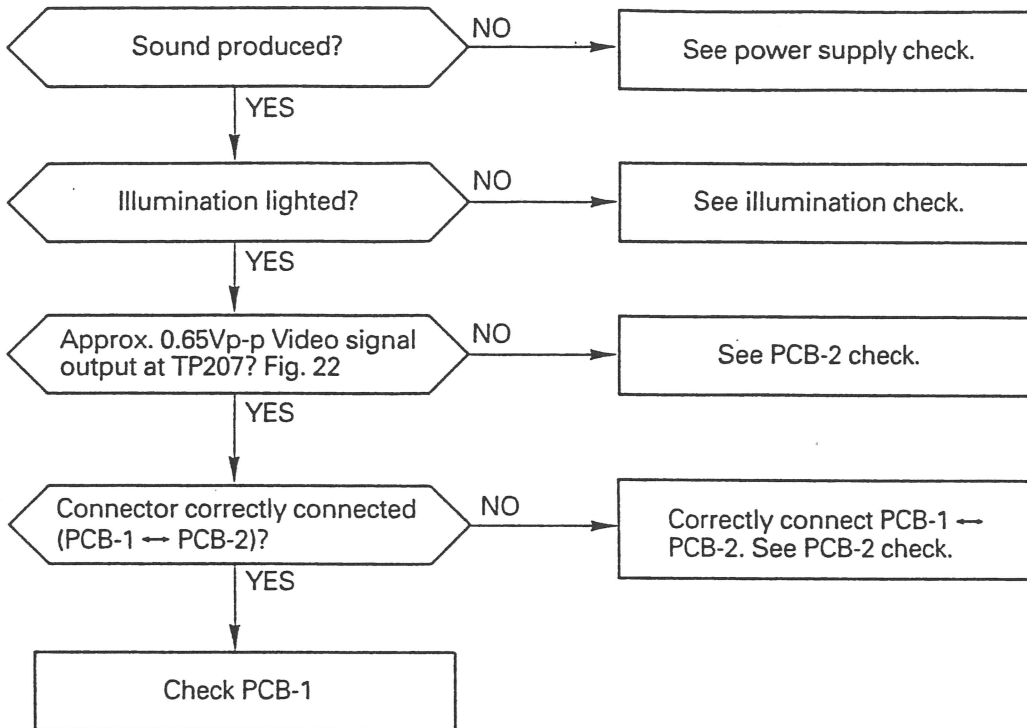

Fig. 22



## 2. NO SOUND

See PCB-2 check.

## 5. SINGLE LINE

LCD panel

## 3. NO COLOR

See PCB-1 check.

## 6. WHITE OR BLACK POT ON LCD PANEL

LCD panel

## 4. NO TUNING

See PCB-2 check.

# 7. CHECK CHART

## 7-1 Power Supply Check (PCB-2)

- Supply 9.0V DC at Power jack of G & G

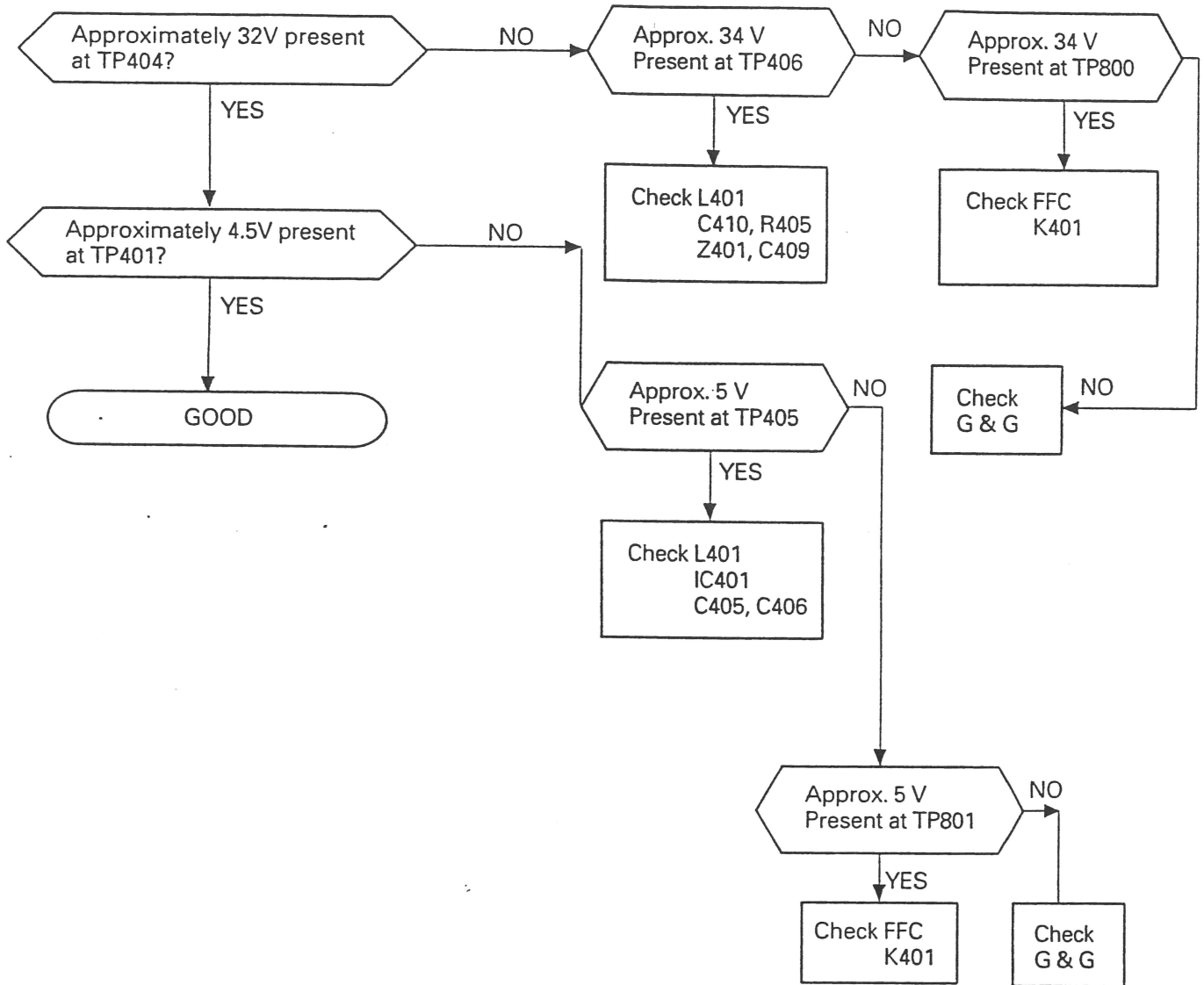

### 7-2 PCB-2 Check

- Connect an external antenna to TV ANT.
- Connect a DC Power Supply (+34.0V) to TP406.
- Connect a DC Power Supply (+5.0V) between TP405 and TP402.

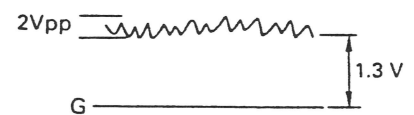
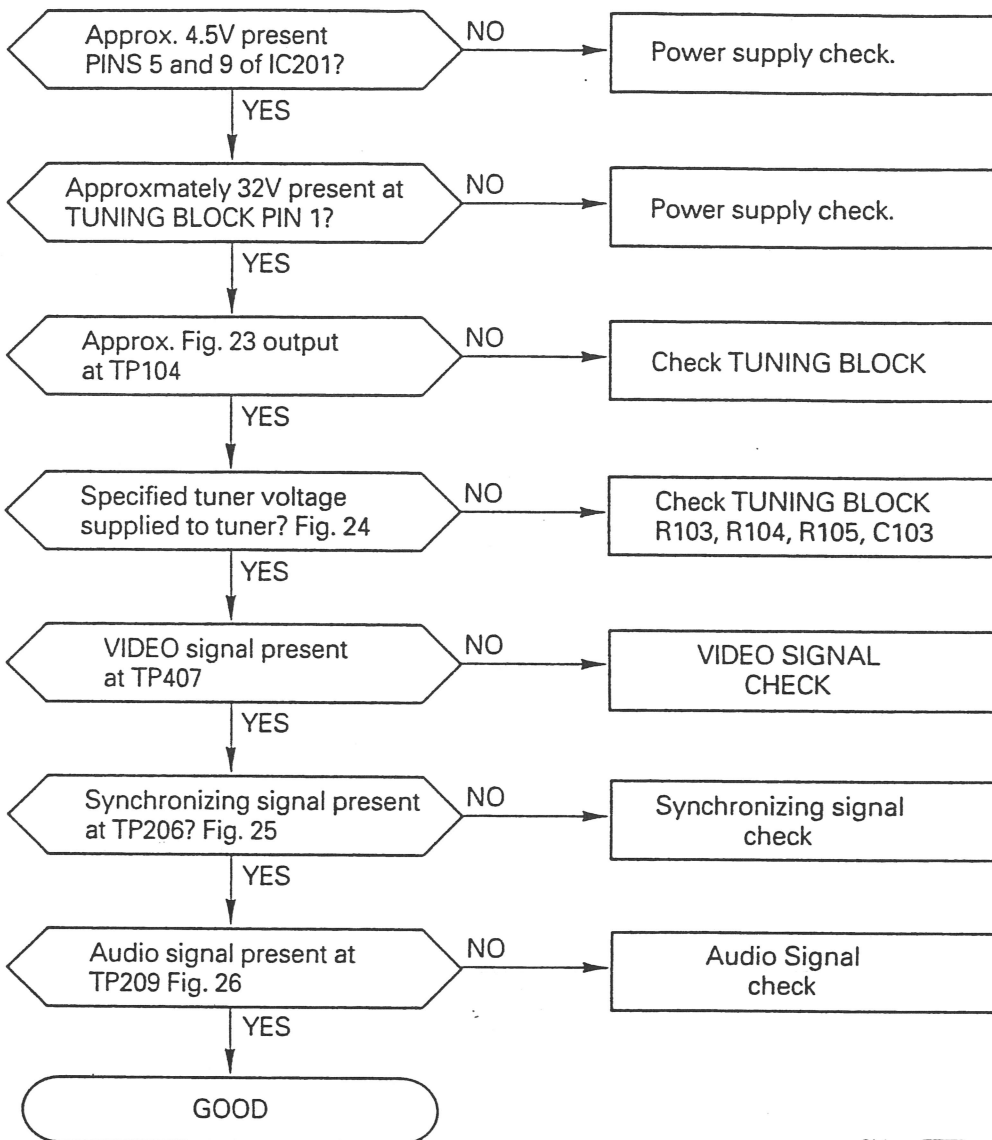

Fig. 26

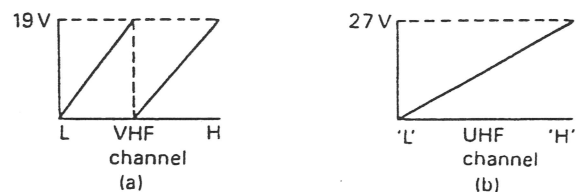
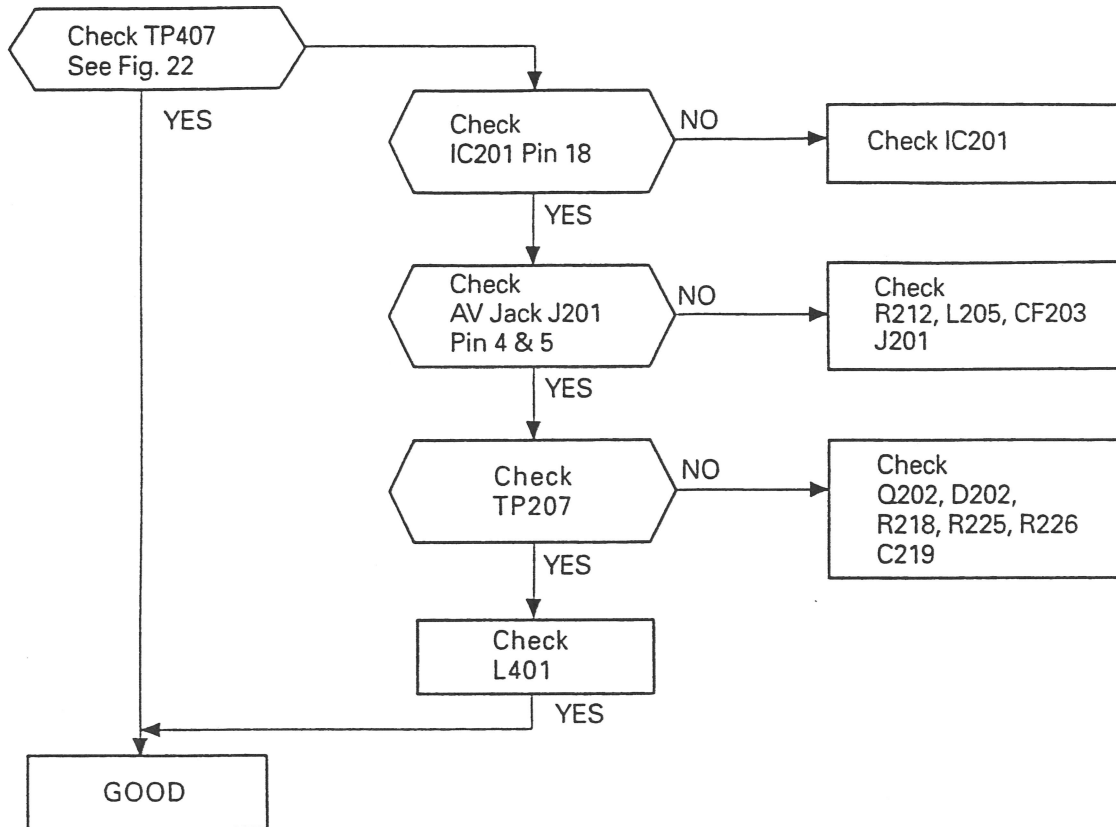

Fig. 23



- No picture
- Video Signal check



TP206 synchronizing signal

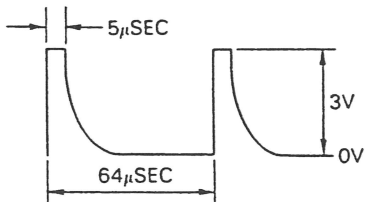

Fig. 25

Fig. 24  
Specified Tuner Voltage

	VHF (L)	VHF (H)	UHF
UB	—	—	4.5V
TU	3-19V	8-19V	2-27V
BS	approx. 20V	approx. 0V	—
VB	4.5V	4.5V	—
MB	4.5V	4.5V	4.5V

NO SYNCHRONIZING

Synchronizing signal check

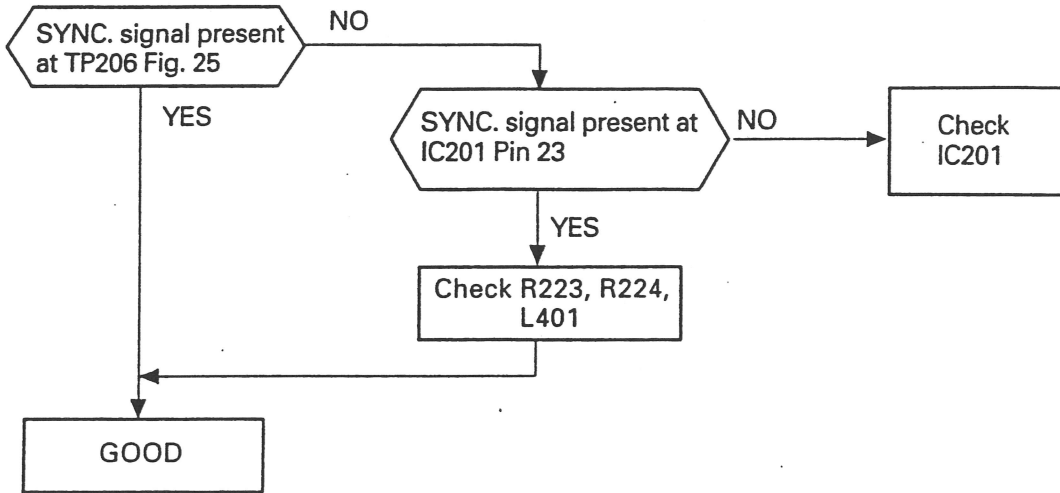

NO SOUND

Audio signal check

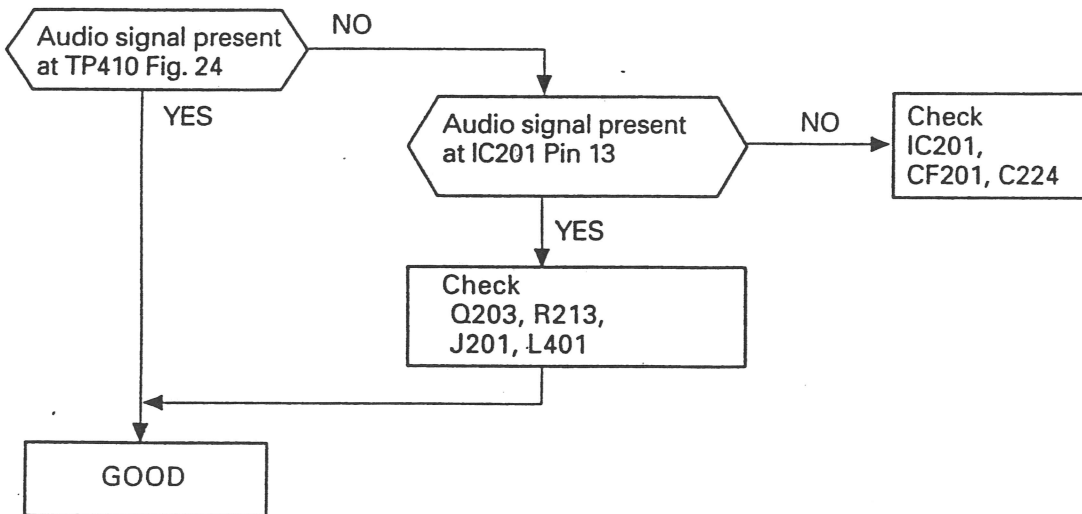

### 7-3 PCB-1 Check

- Connect PCB-1 from PCB-2.

Input video signal to AV Jack (J201).

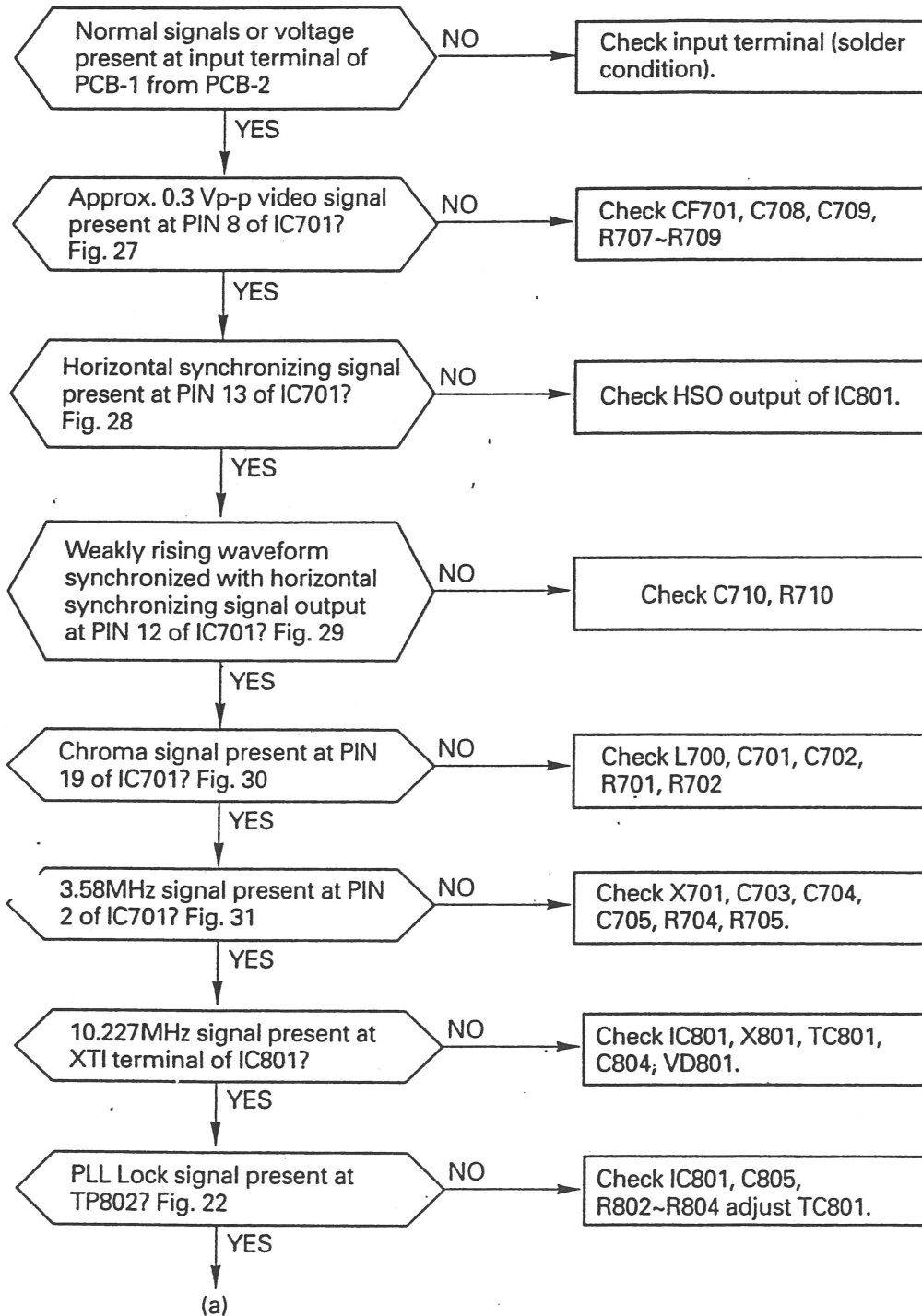

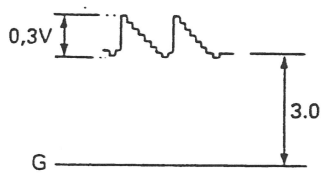
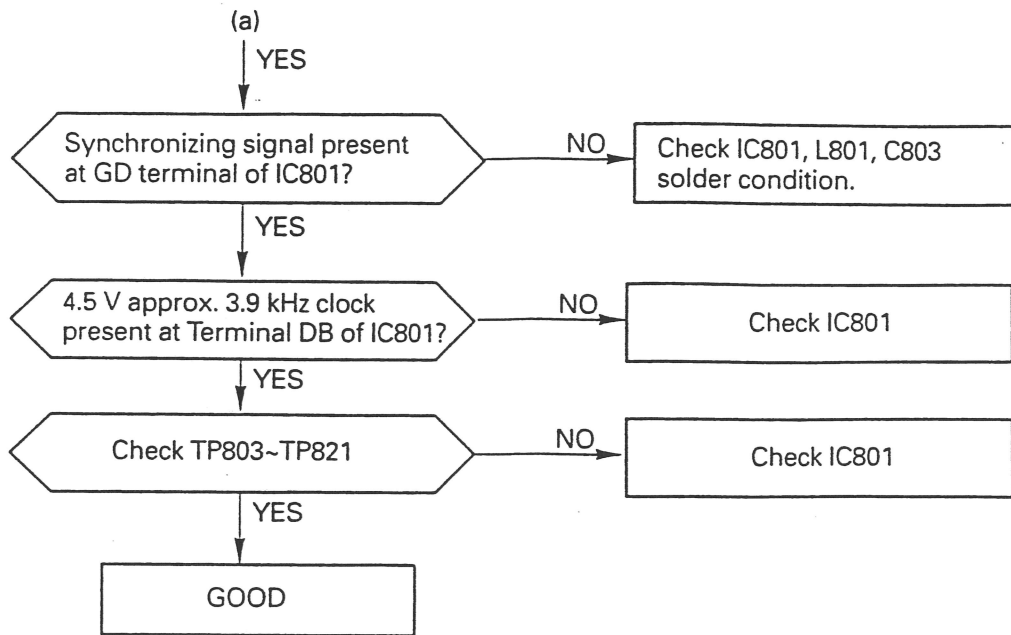

Fig. 27

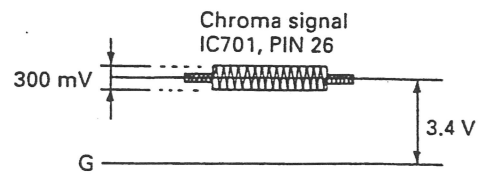

Fig. 30

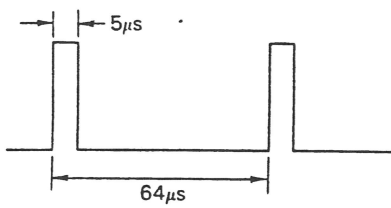

Fig. 28

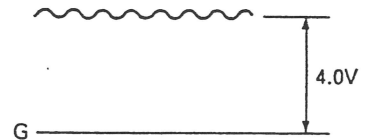

Fig. 31

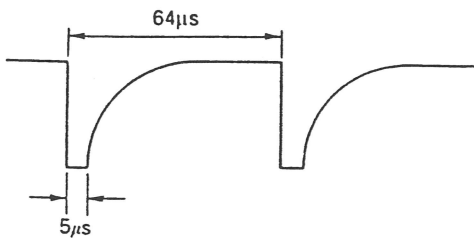

Fig. 29

- NOTES -

# ELECTRIC PARTS LIST

VIDEO PCB ASSEMBLY (PCB-1)

Ref. No.	Description			Mfr's Parts No.
PCB-1	Assembly (PCB-1), PCB, Video Consists of the following:			A51-2810
ITEM	Qty.	Parts code	Description	Manufacture
<b>IC</b>				
IC801	1	A71-1130	F5032B3	CITIZEN
IC701	1	A71-0710	M51403	MITSUBISHI
<b>Coil</b>				
L701	1	A90-0330	15 $\mu$ H	MATSUSHITA
L702	1	A90-0360	56 $\mu$ H	TDK
L801	1	A90-0300	82 $\mu$ H	MATSUSHITA
<b>Xtal</b>				
X801	1	A75-0800	10.218750 MHz	MIYOTA
X701	1	A75-1040	4.43 MHz	TOKYO DENPA
<b>Ceramic Filter</b>				
CF701	1	A75-0150	TPS4.43MJ	MURATA
<b>Varicap Diode</b>				
VD801	1	A73-0280	MA341	MATSUSHITA
<b>Variable Capacitor</b>				
TC801, TC701	2	A89-0030	30P	KYOCERA
<b>Potentiometer</b>				
VR801, VR802	2	A83-0620	50K	ALPS, TEITSU MATSUSHITA
<b>Ceramic Capacitor</b>				
C707	1	W52-0502	5 p F-50V	MURATA KYOCERA
C705, C706	2	W52-6801	68 p F-50V	
C711	1	W52-8201	82 p F-50V	
C718	1	W52-1011	100 p F-50V	
C808	1	W52-1211	120 p F-50V	
C716, C720	2	W52-3311	330 p F-50V	
C702, C703, C803	3	W32-1022	1000 p F-50V	
C708	1	W32-1522	1500 p F-50V	
C710, C717, C807	3	W32-1032	0.01 $\mu$ F-50V	
C701, C704, C709, C713	9	W42-1049	0.1 $\mu$ F-25V	
C714, C719, C804, C805				
C806				
<b>Resistor</b>				
R707, R709	2	W22-0R00	1/10W- 0 $\Omega$	ROHM HOKURIKU KYOCERA
R710, R711	2	W22-2213	1/10W- 220 $\Omega$	
R701	1	W22-3913	1/10W- 390 $\Omega$	
R805, R806, R807, R808, R809, R810	6	W22-5113	1/10W- 510 $\Omega$	
R712, R713, R802	3	W22-1023	1/10W- 1 k $\Omega$	
R702	1	W22-1523	1/10W- 1.5 k $\Omega$	

ITEM	Qty.	Parts code	Description	Manufacture
<b>Resistor</b>				
R703	1	W22-1033	1/10W- 10 k $\Omega$	ROHM HOKURIKU KYOCERA
R705	1	W22-5133	1/10W- 51 k $\Omega$	
R803, R804	2	W22-1043	1/10W- 100 k $\Omega$	
R706	1	W22-1243	1/10W- 120 k $\Omega$	
R704	1	W22-2243	1/10W- 220 k $\Omega$	
R708	1	W22-3343	1/10W- 330 k $\Omega$	
<b>Miscellaneous</b>				
FFC	1	A53-0350	PCB1 contact cable	SATORI

TV RECEIVER PCB ASSEMBLY (PCB-2)

Ref. No.	Description			Mfr's Parts No.
PCB-2	Assembly (PCB-2), PCB, TV Receiver (MK-2101-05)			A51-2820
	(MK-2101-18)			A51-2830
	Consists of the following: (MK-2101-20)			A51-2840
ITEM	Qty.	Parts code	Description	Manufacture
<b>Jack</b>				
J201	1	A62-0040	AV JACK	HOSHIDEN
J101	1	A62-0020	EXT ANT NOT USE (MK-2101-18)	HOSHIDEN
<b>Tuner</b>				
TU101	1	A51-2100	TEPZ5-002A	ALPS
<b>IC</b>				
IC201	1	A71-0230	M51348AFP	MITSUBISHI
IC401	1	A71-2000	MM1060ZMR	MITSUMI
<b>Coil</b>				
L201, L202	2	A80-0160	294SN-0796z	TOKO
L401	1	A79-0460	D-45C	TOKIN
L203	1	A90-0410	0.39 $\mu$ H	TAIYO YUDEN
L204	1	A90-0350	2.7 $\mu$ H (MK-2101)	TAIYO YUDEN
L205	1	A90-0330	15 $\mu$ H	TDK
<b>Ceramic Capacitor</b>				
CF201 (MK-2101-18, -20)	1	A75-0760	SFSL5.5MDB	MURATA
CF201 (MK-2101-05)	1	A75-0830	SFSL6.0MDB	MURATA
CF202 (MK-2101-18, -20)	1	A75-0300	CDA5.5MC30	MURATA
CF202 (MK-2105-05)	1	A75-0310	CDA6.0MC30	MURATA
CF203 (MK-2101-18, -20)	1	A75-0780	TPSL5.5MB	MURATA
CF203 (MK-2101-05)	1	A75-0840	TPSL6.0MB	MURATA
CF204	1	A75-1050	KAF-38.9MS-MP	KYOCERA
<b>Transistor</b>				
Q201	1	W13-3142	C3142	SANYO
Q202, Q203	2	W03-3928	C3928	MITSUBISHI

ITEM	Qty.	Parts code	Description	Manufacture
<b>Diode</b>				
ZD401	1	A73-0390	UPC574J	NEC
D201, D202	2	A73-0340	RLS-73	ROHM
<b>Potentionmeter</b>				
VR401	1	A83-0350	100K	ALPS
VR201, VR202	2	A83-0530	50K	MATSUSHITA
<b>Electrolytic Capacitor</b>				
C409	1	A86-0010	1 $\mu$ F/50V	ELNA RUBICON NICHICON
C222	1	A86-0430	2.2 $\mu$ F/50V	
C205, C218	2	A86-0060	3.3 $\mu$ F/50V	
C410	1	A86-0510	4.7 $\mu$ F/50V	
C204, C405, C406	3	A86-0350	47 $\mu$ F/10V	
C401	1	A86-0280	100 $\mu$ F/6.3V	
C219	1	A86-0450	N 10 $\mu$ F/10V	
<b>Ceramic Capacitor</b>				
C211	1	W52-2701	27 p F-50V	MURATA KYOCERA
C212, C213	2	W52-6201	62 p F-50V	
C223	1	W52-8211	820 p F-50V	
C201, C203, C206	3	W32-1022	1000 p F-50V	
C216	1	W32-1522	1500 p F-50V	
C220	1	W32-5622	5600 p F-50V	
C202, C209, C214, C217, C221, C224	6	W32-1032	0.01 $\mu$ F-50V	
C101, C102, C104, C105, C207, C208, C215, C402, C407	9	W42-1049	0.1 $\mu$ F-25V	
C103, C210	2	W43-2244	0.22 $\mu$ F-25V	
<b>Resistor</b>				
R001	1	W22-0R00	1/10W-0 $\Omega$	ROHM HOKURIKU KYOCERA
R103	1	W22-0R00	1/10W-0 $\Omega$	
R227	1	W22-4R73	1/10W-4.7 $\Omega$	
R205	1	W22-2203	1/10W-22 $\Omega$	
R228	1	W22-5103	1/10W-51 $\Omega$	
R201	1	W22-1813	1/10W-180 $\Omega$	
R218	1	W22-2213	1/10W-220 $\Omega$	
R204	1	W22-2713	1/10W-270 $\Omega$	
R212	1	W22-3313	1/10W-330 $\Omega$	
R213, R214, R222, R224	4	W22-4713	1/10W-470 $\Omega$	
R223, R405	2	W22-1023	1/10W-1k $\Omega$	
R219	1	W22-1023	1/10W-1k $\Omega$	
R203	1	W22-2223	1/10W-2.2k $\Omega$	
R211	1	W22-3323	1/10W-3.3k $\Omega$	
R217	1	W22-4723	1/10W-4.7k $\Omega$	
R202	1	W22-6823	1/10W-6.8k $\Omega$	
R207	1	W22-8223	1/10W-8.2k $\Omega$	
R225, R226	2	W22-1033	1/10W-10k $\Omega$	



ITEM	Qty.	Parts code	Description	Manufacture
<b>Resistor</b>				
R102	1	W22-1833	1/10W-18k $\Omega$	ROHM
R210	1	W22-5133	1/10W-51k $\Omega$	
R105	1	W22-1043	1/10W-100k $\Omega$	HOKURIKU
R221	1	W22-1843	1/10W-180k $\Omega$	ROHM
R401	1	W22-2243	1/10W-220k $\Omega$	HOKURIKU
R215, R216	2	W22-3943	1/10W-390k $\Omega$	KYOCERA
R101, R104	2	W22-1053	1/10W-1M $\Omega$	
<b>Miscellaneous</b>				
K401	1	A52-0860	9602S-9L	IRISO
K400	1	A54-0310	Z-279-8FD1	HONDA
400	1	A11-1170	CH. indicator	TEITSU
401	1	A12-0530	Lug plate of Ant.	SANKO

- NOTES -

## EXPLODED VIEW PARTS LIST

ITEM	Parts code	Description	Manufacture
100	A01-5740	Top Case (Ass'y) (MK-2101-05, -20)	SEGA
100	A01-5780	Top Case (Ass'y) (MK-2101-18)	SEGA
100	A01-6140	Top Case (Ass'y) (MK-2101-20 White)	SEGA
101	A05-0500	Band Select Knob	CITIZEN
102	A05-0580	Color Adjust Knob	CITIZEN
200	A01-5760	Bottom Case (Ass'y) (MK-2101-05)	SEGA
200	A01-5800	Bottom Case (Ass'y) (MK-2101-18)	SEGA
200	A01-5820	Bottom Case (Ass'y) (MK-2101-20)	SEGA
200	A01-6160	Bottom Case (Ass'y) (MK-2101-20 White)	SEGA
ANT201	A64-0240	Rod Antenna	YOKOO
PCB1	A51-2340	Video PCB Ass'y	CITIZEN
PCB2	A51-2830	TV Receiver PCB Ass'y (MK-2101-05)	CITIZEN
PCB2	A51-2840	TV Receiver PCB Ass'y (MK-2101-18)	CITIZEN
PCB2	A51-2440	TV Receiver PCB Ass'y (MK-2101-20)	CITIZEN
400	A11-1170	Channel Indicator Ass'y	TEITSU
K401	A54-0860	9602S-9L	IRISO DENSHI
VR401	A83-0350	Color Potentiometer	ALPS
501	Y23-6806	Tapping Screws B2 × 8mm Pan Head (3) Black	TOKYO BYOUKANE
502	A22-0330	Tapping Screws B2 × 5mm LH Black	TOKYO BYOUKANE
503	A22-0320	Machine Screw M3 × 8mm Flat Head (ø6 × 1t) Ni	TOKYO BYOUKANE
504	A22-0220	Tapping Screw B1.7 × 5mm Flat Head (ø3.5 × 0.9t) Ni	TOKYO BYOUKANE
505	Y04-3001	Spring Lock Washer Ni	TOKYO BYOUKANE
600	A02-1150	Stand	SEGA