

# THE POTENTIOMETER HANDBOOK

Welcome to the on-line version of the “ The Potentiometer Handbook” originally published in hard cover by McGraw-Hill Book Company.

We have made only a few changes to the original in the area of Industry Standards and Military Specifications.

The technology represented in this handbook has had no significant change in years and remains as viable today as it was when this volume was published.

To use this version you can scroll down page by page or you can go to the Table of Contents to select a specific subject or chapter and click on the title or page number to go directly to the section you selected.

To return to the previous view simply right click your mouse and select “Previous View” from the pop up window.

In order for these functions to operate properly you must use Acrobat Reader 8 or higher. If you need to download Acrobat for free, use the Acrobat icon below.

For more information you can also go to the Bourns web site at [www.bourns.com](http://www.bourns.com) , select applications information under the “About Us” button then selecting the “Library button”.

You may also want to review application information from the “Trimmer Primer” by using link below:  
<http://www.bourns.com/pdfs/trmrpmr.pdf>



Copyright 1975, 2008

Adobe and Adobe Reader are registered trademarks of Adobe Systems Incorporated.

# ACKNOWLEDGEMENTS

## PHOTOGRAPHS CONTRIBUTED BY:

AMI MEDICAL ELECTRONICS  
BELL AEROSYSTEMS  
BIDDLE CO., JAMES G.  
CALSPAN CORP.  
CENTRAL SCIENTIFIC CO.  
CETEC, INC.  
DUNCAN ELECTRONICS, INC.  
GENERAL RADIO CO.  
HEWLETT-PACKARD

INTERSTATE ELECTRONICS CORP.  
KRAFT SYSTEMS, INC.  
LEEDS AND NORTHRUP  
POWER DESIGNS, INC.  
SPACE-AGE CONTROL, INC.  
TEKTRONIX, INC.  
WEYERHAUSER CO.  
WILLI STUDER, SWITZERLAND

## INDUSTRY STANDARDS

REPRINTED BY PERMISSION OF THE VARIABLE RESISTIVE COMPONENTS INSTITUTE





# **THE POTENTIOMETER HANDBOOK**

## **USERS' GUIDE TO COST-EFFECTIVE APPLICATIONS**

Written for  
BOURNS, INC.

By

**CARL DAVID TODD, P.E.**  
CONSULTING ENGINEER

*ASSOCIATE EDITORS*

**W. T. HARDISON**

Product Marketing Specialist

Trimpot Products Division

Bourns, Inc.

**W. E. GALVAN**

Applications Engineer

Trimpot Products Division

Bourns, Inc.

**McGRAW-HILL BOOK COMPANY**

New York	St. Louis	San Francisco	Auckland	Düsseldorf
Johannesburg	Kuala Lumpur	London	Mexico	Montreal
New Delhi	Panama	Paris	São Paulo	Singapore
	Sydney	Tokyo	Toronto	

Library of Congress Cataloging in Publication Data

Todd, Carl David.

The potentiometer handbook.

1. Potentiometer—Handbooks, manuals, etc.
2. Electric resistors—Handbooks, manuals, etc.

I. Bourns, inc.      II. Title.

TK7872.P6T63      621.37'43      75-20010

ISBN 0-07-006690-6

Copyright © 1975 by Bourns, Inc. All rights reserved. Printed in the United States of America. No part of this publication may be reproduced, stored in a retrieval system, or transmitted, in any form or by any means, electronic, mechanical, photocopying, recording, or otherwise, without the prior written permission of the publisher.

1234567890 MUBP 784321098765

The information conveyed in this book has been carefully reviewed and believed to be accurate and reliable; however, no responsibility is assumed for the operability of any circuit diagram or inaccuracies in calculations or statements. Further, nothing herein conveys to the purchaser a license under the patent rights of any individual or organization relating to the subject matter described herein.



# PREFACE

In the decades following the advent of the transistor, electronic technology experienced explosive growth. Thousands of new circuits were generated annually. The demand for variable resistive components to adjust, regulate or control these circuits shared in the expansion.

The number of applications for variable resistive components has increased significantly. This is contrary to predictions of a few soothsayers of the '60's who interpreted the miniaturizing effects of integrated circuit technology as a threat to these components. Potentiometers will continue to enjoy strong growth into the foreseeable future. This optimistic forecast is particularly true in consumer and industrial applications where potentiometers provide the cost-effective solution in trimming applications and the ever-present necessity of control for man-machine interface.

Many articles, booklets, and standards have been published on potentiometers; yet, there is no single, comprehensive source of practical information on these widely used electronic components. It is this void that *The Potentiometer Handbook* is intended to fill.

One objective of this handbook is to improve communications between potentiometer manufacturers and users. To this end, explanations of performance specifications and test methods, are included. Common understanding of terminology is the key to communication. For this reason, lesser known as well as preferred terminology are included, with emphasis on the latter. Hopefully, this will create the base for easy, accurate dialogue. Over 230 photos, graphs and drawings illustrate and clarify important concepts.

This book assumes the reader has a knowledge of electronic and mathematical fundamentals. However, basic definitions and concepts can be understood by nontechnical personnel. The major portion of this text is written for systems and circuit designers, component engineers, and technicians as a practical aid in design and selection. It is an important reference and working handbook oriented towards practical application ideas and problem solving. For the student, it introduces the basic component, its most common uses, and basic terminology.

Enough objective product design and manufacturing process information is in the text to allow the user to understand basic differences in materials, designs, and processes that are available. This will sharpen his judgment on 'cost-versus-performance' decisions. Thus, he can avoid over-specifying product requirements and take advantage of the cost-effectiveness of variable resistive devices.

Also included are hints and design ideas compiled over the years. As with any discipline, these guidelines are often discovered or developed through unfortunate experience or misapplication. Most chapters conclude with a summary of key points for quick review and reference.

Speaking of misapplication, Chapter 9, *To Kill a Potentiometer*, is a tongue-in-cheek *potpourri* of devious methods to wipe out a potentiometer. This is a lighthearted approach to occasional serious problems caused by human frailties. Not much more need be said except *before* all else fails, *read the book*, or at least this chapter!

Suggestions from readers on improving this volume are encouraged and welcomed. Subsequent editions will include the results of these critiques together with advanced material relating to the state-of-art in potentiometer design and application.

*W. T. Hardison*



# CONTENTS



ii *Acknowledgements*

v *Preface*

xi *List of illustrations*

## 1 Chapter ONE — INTRODUCTION TO POTENTIOMETERS

Historical evolution and milestones of variable resistive devices from mid 19th century to present. Development of the basic concepts of resistive element and moveable contact. Electrical and mechanical fundamentals including elementary readout devices.

1 HISTORICAL BACKGROUND

6 PRACTICAL DEVELOPMENT OF THE POTENTIOMETER

## 17 Chapter TWO — ELECTRICAL PARAMETERS

Interpretation of potentiometer electrical parameters in written and mathematical form without regard to application. Each definition is supplemented with terminology clarification and an example of electronic circuitry that will allow physical demonstration of each concept.

17 INTRODUCTION

18 TOTAL RESISTANCE, TR

18 ABSOLUTE MINIMUM RESISTANCE, MR

20 END RESISTANCE, ER

20 MINIMUM AND END VOLTAGE RATIOS

22 CONTACT RESISTANCE, CR

26 CONTACT RESISTANCE VARIATION, CRV

28 EQUIVALENT NOISE RESISTANCE, ENR

29 ENR and CRV

30 OUTPUT SMOOTHNESS, OS

31 ADJUSTABILITY, A

33 TEMPERATURE COEFFICIENT OF RESISTANCE, TC

34 RESOLUTION

37 CONFORMITY

40 ABSOLUTE CONFORMITY

40 LINEARITY

45 POWER RATING

47 INSULATION RESISTANCE, IR

48 ELECTRICAL PARAMETERS SUMMARY CHART



## 51 Chapter THREE — APPLICATION FUNDAMENTALS

Presentation of the *fundamental* operational modes possible when applying the potentiometer in electrical circuits. Basic explanations assume ideal, theoretical conditions. Significance and effect of the parameters in Chapter Two. Subjects include error compensation, adjustment range control, data input and offset capability.

- 51 INTRODUCTION
- 51 VARIABLE VOLTAGE DIVIDER MODE
- 62 VARIABLE CURRENT RHEOSTAT MODE
- 71 DATA INPUT
- 74 APPLICATION FUNDAMENTALS SUMMARY CHART

## 77 Chapter FOUR — APPLICATION AS A CIRCUIT ADJUSTMENT DEVICE

The potentiometer as a *circuit* component without regard to total system. Analog and digital applications with transistors, diodes, fixed resistors, capacitors, integrated circuits and instruments.

- 77 INTRODUCTION
- 78 POTENTIOMETER OR FIXED RESISTORS?
- 78 POWER SUPPLY APPLICATIONS
- 81 OPERATIONAL AMPLIFIER APPLICATIONS
- 87 DIGITAL CIRCUITS
- 89 INSTRUMENTS
- 91 MISCELLANEOUS APPLICATIONS

## 97 Chapter FIVE — APPLICATION AS A CONTROL DEVICE

The potentiometer as a *system* component. Application in interesting systems, e.g. oscilloscopes, power supplies, function generators, meters and recorders.

- 97 INTRODUCTION
- 98 BASICS OF CONTROL
- 101 INSTRUMENT CONTROLS
- 104 AUDIO CONTROLS
- 106 MISCELLANEOUS CONTROLS
- 112 SUMMARY



## 115 Chapter SIX — APPLICATION AS A PRECISION DEVICE

The potentiometer in systems requiring *high* accuracy. Importance of electro-mechanical parameters in precision applications. Applications in systems and circuits where accuracy is the most important consideration.

115	INTRODUCTION
115	OPERATIONAL CHARACTERISTICS
115	POWER RATING
118	FREQUENCY CHARACTERISTICS
120	LINEAR FUNCTIONS
121	NONLINEAR FUNCTIONS
126	VOLTAGE TRACKING ERROR
127	CLOSED LOOP FUNCTIONS
127	MECHANICAL PARAMETERS
129	PHASING
130	NONWIREWOUND PRECISION POTENTIOMETERS
133	LINEAR DISPLACEMENT TRANSDUCER
133	LOW TORQUE POTENTIOMETERS
134	COARSE/FINE DUAL CONTROL
135	POSITION INDICATION TRANSMISSION
136	THE X-22A, V/STOL AIRCRAFT
137	A DENDROMETER
138	SORTING BRIDGE
138	MULTI-CHANNEL MAGNETIC TAPE RECORDER



## **143 Chapter SEVEN — CONSTRUCTION DETAILS AND SELECTION GUIDELINES**

Description of the various potentiometer constituent parts. Advantages and disadvantages of the diverse technologies available to construct a variable resistance device. Selection charts are included for quick reference to cost-effective applications.

143	INTRODUCTION
143	RESISTIVE ELEMENTS
159	TERMINATIONS
163	CONTACTS
166	ACTUATORS
171	HOUSINGS
171	SUMMARY
174	SELECTION CHARTS

## **177 Chapter EIGHT — PACKAGING GUIDELINES**

How to install potentiometers using various methods and techniques. The importance of accessibility, orientation and mounting when packaging the potentiometer in electronic assemblies.

177	INTRODUCTION
177	PLAN PACKAGING EARLY
178	DETERMINE ACCESSIBILITY
180	CONSIDER OTHER PACKAGING RESTRICTIONS
180	CHOOSE THE PROPER PHYSICAL FORM
180	MOUNTING METHODS
181	PACKAGE SELECTION CHARTS
189	STRESS AND STRAIN
189	SOLDERING PRECAUTIONS
191	SOLVENTS
191	ENCAPSULATION

## **193 Chapter NINE — TO KILL A POTENTIOMETER**

The misadventures of mischievous and misdirected KUR KILLAPOT that result in misuse and misapplication of potentiometers.

194	MAYHEM
199	SLAUGHTERING
201	ZAP
207	SUMMARY CHARTS

## **209 Appendices**

211	I. STANDARDS OF THE VARIABLE RESISTIVE COMPONENTS INSTITUTE
259	II. MILITARY SPECIFICATIONS
283	III. BIBLIOGRAPHY OF FURTHER READING
287	IV. METRIC CONVERSION TABLE
289	V. ABBREVIATIONS AND MATHEMATICAL SYMBOLS

## **293 Index**



## LIST OF ILLUSTRATIONS

PAGE	FIG.	DESCRIPTION
1	1-1	Early 20th Century slide-wire rheostat
2	1-2	The carbon pile of the 19th Century
2	1-3	The carbon pile in the early 20th Century
3	1-4	Simple slide-wire variable resistance device
3	1-5	Measuring instrument to determine unknown voltage
4	1-6	Modern instrument for precision ratio measurement
5	1-7	A patent drawing for a device invented over 100 years ago
7	1-8	A patent drawing from the early 1900's
8	1-9	A. O. Beckman's patent for a 10-turn potentiometer
9	1-10	Marlan E. Bourns' patent drawing for miniature adjustment potentiometer
10	1-11	Adjustment potentiometers of today
11	1-12	Winding resistance wire on insulated tube
11	1-13	A flat mandrel could be used
11	1-14	Curved mandrel saves space and allows rotary control
11	1-15	Shaping mandrel into helix puts long length in small space
12	1-16	Resistive elements of composition materials
12	1-17	A simple lead screw aids setability
13	1-18	A worm gear may be added to the rotary potentiometer
13	1-19	A simple sliding contact position indicating device
13	1-20	Accurate devices for sliding contact position indication
14	1-21	Generic names
17	2-1	Schematic representation
18	2-2	Measurement of total resistance
19	2-3	Illustration of minimum resistance and end resistance
20	2-4	Measurement of minimum resistance and end resistance
21	2-5	Production testing of minimum resistance
21	2-6	Measurement of minimum voltage and end voltage
23	2-7	Construction affects minimum and end-set parameters
24	2-8	Experiment to demonstrate contact resistance
24	2-9	Potentiometer schematic illustrating contact resistance
25	2-10	Path of least resistance through element
25	2-11	Contact resistance varies with measurement current
25	2-12	Measurement of contact resistance
26	2-13	Demonstration of contact resistance variation
26	2-14	Current for CRV measurement of cermet elements
27	2-15	Oscilloscope display of CRV
27	2-16	Equipment configuration for CRV demonstration
28	2-17	Load current is a contributor to ENR
29	2-18	A varying number of turns make contact with the wiper
29	2-19	Demonstration of ENR
30	2-20	Oscilloscope traces of ENR
31	2-21	Output smoothness demonstration



PAGE	FIG.	DESCRIPTION
31	2-22	Evaluation of the output smoothness recording
32	2-23	Adjustability of in-circuit resistance
32	2-24	Adjustability of voltage division
33	2-25	Temperature coefficient demonstration
34	2-26	Linear wirewound potentiometer element
35	2-27	Output voltage vs. travel
36	2-28	Demonstrating voltage resolution
36	2-29	Input and output waveforms for the filter in Fig. 2-28
37	2-30	Conformity
38	2-31	Graphical representation of some important definitions
40	2-32	Evaluation of conformity
41	2-33	Actual output curve for one particular potentiometer
43	2-34	Absolute linearity
43	2-35	Independent linearity
44	2-36	A method to evaluate independent linearity
44	2-37	A method to evaluate independent linearity
46	2-38	Zero based linearity
46	2-39	Terminal based linearity
47	2-40	Demonstration of insulation resistance
48	2-41	A summary of electrical parameters
51	3-1	The basic variable voltage divider
53	3-2	A two-point power rating assumes linear derating
54	3-3	A two-point power rating implies a maximum
55	3-4	Variable voltage divider with significant load current
56	3-5	Loading error is a function of $R_L$ and $R_T$
56	3-6	Loading errors for a variable voltage divider
57	3-7	Maximum uncompensated loading error
57	3-8	Power dissipation is not uniform in a loaded voltage divider
58	3-9	Total input current for the circuit of Fig. 3-8
58	3-10	Limited compensation for loading by use of a single resistor
60	3-11	Output error for several degrees of compensation
60	3-12	Compensated loading error where $R_L = 10R_T$
61	3-13	Compensated loading error where $R_1 = 3R_L$
61	3-14	Adjustment range is fixed by resistors
62	3-15	Effective resolution can be improved by loading
63	3-16	Effective resolution in center is improved by loading
63	3-17	Region of best effective resolution is shifted
64	3-18	Variable resistance used to control a current
66	3-19	Variable current rheostat mode when $R_M = R_E$
67	3-20	Variable current rheostat mode when $R_M \neq R_E$
69	3-21	Fixed resistors vary the adjustment range
70	3-22	Fixed resistance in parallel controls the range
70	3-23	Output function for circuit of Fig. 3-21E
71	3-24	Typical screened and engraved dials



PAGE	FIG.	DESCRIPTION
71	3-25	A turns counting dial
72	3-26	A multiturn dial with a clock-like scale
72	3-27	Digital type, multiturn dials
73	3-28	Example of offsetting
73	3-29	A circuit to optimize offset and adjustment of data input
74	3-30	Summary of application fundamentals
79	4-1	Output of a voltage regulator is affected by tolerances
79	4-2	A potentiometer compensates for component tolerances
80	4-3	Potentiometers in a power supply regulator
81	4-4	Adjustment of bias current through a VR diode
82	4-5	Generation of a temperature compensating voltage
82	4-6	Offset adjustment for operational amplifiers with internal balance
83	4-7	Offset adjustment for various operational amplifier configurations
84	4-8	Gain adjustment for non-inverting amplifiers
85	4-9	Gain adjustment for inverting amplifiers
86	4-10	Active band pass filter with variable Q
86	4-11	Variable capacitance multiplier
87	4-12	Potentiometer used to adjust timing of monostable
88	4-13	Integrated circuit timer application
89	4-14	Clock circuit uses IC monostable
90	4-15	Photocell amplifier for paper tape reader
90	4-16	A to D converters use potentiometers for offset and full-scale adjustment
91	4-17	The electronic thermometer
91	4-18	Potentiometer adjusts frequency in phase locked loop
92	4-19	Trimming potentiometers used to optimize linearity error
93	4-20	A nonlinear network using diodes and potentiometers
94	4-21	Trimming potentiometers perform RF tuning
94	4-22	A high power, low resistance custom designed rheostat
95	4-23	A custom designed multi-potentiometer network
95	4-24	Adjustment of electrical output of heart pacer
98	5-1	Control of frequency in an oscillator
99	5-2	Independent control of oscillator ON and OFF times
100	5-3	Control of the percent duty cycle in an oscillator
102	5-4	Modern test oscilloscope
103	5-5	Function generator uses potentiometers for control and calibration
104	5-6	Block diagram of pulse generator
105	5-7	Laboratory power supply
106	5-8	Photometer circuit
107	5-9	Zero and offset null on a voltmeter
108	5-10	Master mixer board for a recording studio
108	5-11	Remote control system for model aircraft
109	5-12	Ganged potentiometers yield phase shift control
110	5-13	Various constant impedance attenuators
111	5-14	Simple motor speed control
111	5-15	Temperature control circuit uses a balanced bridge
112	5-16	Multifunction control
113	5-17	Design factors and typical control applications



PAGE	FIG.	DESCRIPTION
116	6-1	Power derating curves for single turn precision potentiometers
117	6-2	Trend in power rating with change in diameter
117	6-3	Power derating curve for a metal case rheostat
117	6-4	Power derating curve for a plastic case rheostat
119	6-5	Quadrature voltage at a specified input voltage and frequency
119	6-6	Quadrature voltage measurement
120	6-7	Lumped-parameter approximation for wirewound potentiometers
121	6-8	Trend in resolution with a change in diameter
121	6-9	Trend in linearity with a change in diameter
122	6-10	Table of standard nonlinear functions
124	6-11	A potentiometer with a loaded wiper circuit
125	6-12	Output voltage vs. wiper position with and without wiper load
125	6-13	A straight line approximation of a nonlinear function by voltage clamping
128	6-14	Servo mount and screw mount potentiometers
128	6-15	Maximum torque values, single section units only
130	6-16	Clamp ring style, phased potentiometers
131	6-17	Contact resistance
131	6-18	Linearity error (%) for various $R_L/R_T$ ratios
132	6-19	Current tap for nonwirewound element
132	6-20	Voltage tap for nonwirewound element
133	6-21	Cable type linear displacement transducer
134	6-22	Spectrum analyzer with coarse/fine dual control
135	6-23	A basic position transmission system
136	6-24	An experimental aircraft
137	6-25	Patchboard used with the aircraft of Fig. 6-25
137	6-26	Dendrometer for monitoring tree growth
138	6-27	A bridge for high speed sorting of resistors
139	6-28	Multi-channel magnetic tape recorder
140	6-29	A tape tension sensor
140	6-30	View of tape drive mechanics and electronics
144	7-1	Relation of resistance to wire diameter
145	7-2	Automatic machine to produce a resistance element
146	7-3	A variety of mandrel shapes to achieve various output functions
147	7-4	Same slope ratio may require different construction methods
147	7-5	Stepping mandrel to change slope
148	7-6	Changing wire resistivity to change slope
149	7-7	Use of tapping to achieve inversion
150	7-8	Screening process for cermet element
151	7-9	A temperature controlled kiln



PAGE	FIG.	DESCRIPTION
151	7-10	A ceramic substrate attached directly to the shaft
153	7-11	Conductive plastic element for a multi-turn potentiometer
155	7-12	Three resistance tapers taken from MIL-R-94B
156	7-13	Film element designed for linear approximation of ideal taper
156	7-14	Film elements designed to provide a taper
157	7-15	Addition of current collector sharpens changes in slope
158	7-16	Nonlinear, conductive plastic elements
158	7-17	Comparison of popular element types
159	7-18	A variety of typical external terminations
160	7-19	Brazing operation for wirewound element termination
160	7-20	Methods of termination in wirewound potentiometers
161	7-21	Connection to cermet element made with conductive pads
162	7-22	Methods of termination in nonwirewound potentiometers
163	7-23	A simple contact between two conducting members
164	7-24	Moveable contacts come in many different forms
164	7-25	Simple element showing equipotential lines
165	7-26	Current crowding in single contact
165	7-27	A single contact causes increased contact resistance
166	7-28	Multiple contacts lower contact resistance
167	7-29	Several typical rotary shaft actuators
168	7-30	Interior of multiturn potentiometer
168	7-31	Interior of a lead screw actuated potentiometer
169	7-32	Typical design of a worm-gear actuated potentiometer
170	7-33	A single turn adjustment potentiometer
172	7-34	Linear actuated potentiometer used in a servo system
172	7-35	Slider potentiometer used as an audio control
173	7-36	Housings are molded by this equipment
174	7-37	Selection charts
178	8-1	Planning ahead can avoid later frustration
179	8-2	Access to trimmers on PC cards
179	8-3	Access hole provided through PC card
181	8-4	Trimmer potentiometer package selection chart
182	8-5	Control potentiometer package selection chart
183	8-6	Precision ten turn potentiometer package selection chart
184	8-7	Precision single turn potentiometer package selection chart
186	8-8	Trimmer potentiometer access through panel
187	8-9	Low-profile mounting
187	8-10	Potentiometer inverted to permit circuit side adjustment
188	8-11	Bushing mount potentiometer
188	8-12	Snap-in mounting potentiometers
189	8-13	Printed circuit board simplifies panel wiring
190	8-14	Shaft extensions provide increased packaging density
190	8-15	Adjustment potentiometer mounting hardware
191	8-16	To bend leads, hold with pliers
191	8-17	Solvents to avoid



# INTRODUCTION TO POTENTIOMETERS



Chapter

1

## CONTROLS FOR FLOW OF ELECTRONS

*. . . Long before the mad search for the philosopher's stone or the formula for transmutation of base metals into gold by medieval alchemists, the speculative Greek philosophers had contemplated upon the structure of matter. One, Empedocles brought forth the theory of the structure of matter from the four elements of earth, air, fire and water, but these he subordinated, as complex products composed of primordial indestructible atoms, which were animated by love and hatred. Strangely, our present understanding of the structure of matter could be described in much the same words as these, except that the four elements are now 92 and the indestructible atoms are unit charges of electricity – protons and electrons. Instead of being animated by love and hatred, as Empedocles thought, they are motivated by the repulsion or attraction between like and unlike electrical charges. . . .*

*Electrons move readily through some substances, called conductors, and scarcely at all through others, called resistors. This happy property of substances, therefore, provides a means by which electronic pressures (voltage) may be controlled by the introduction of resistors of proper dimensions and characteristics into the electrically conducting circuit.*

*Central Scientific Co., Chicago, Ill.*

## HISTORICAL BACKGROUND

The italicized quote above is taken from an early 20th century catalog. This particular manufacturer used this bit of technical history as an introduction to variable resistive devices of the

type shown in Fig. 1-1, but the history of variable resistive devices is known to predate the turn of the century by more than thirty years.

When Galvani and Volta discovered that elec-

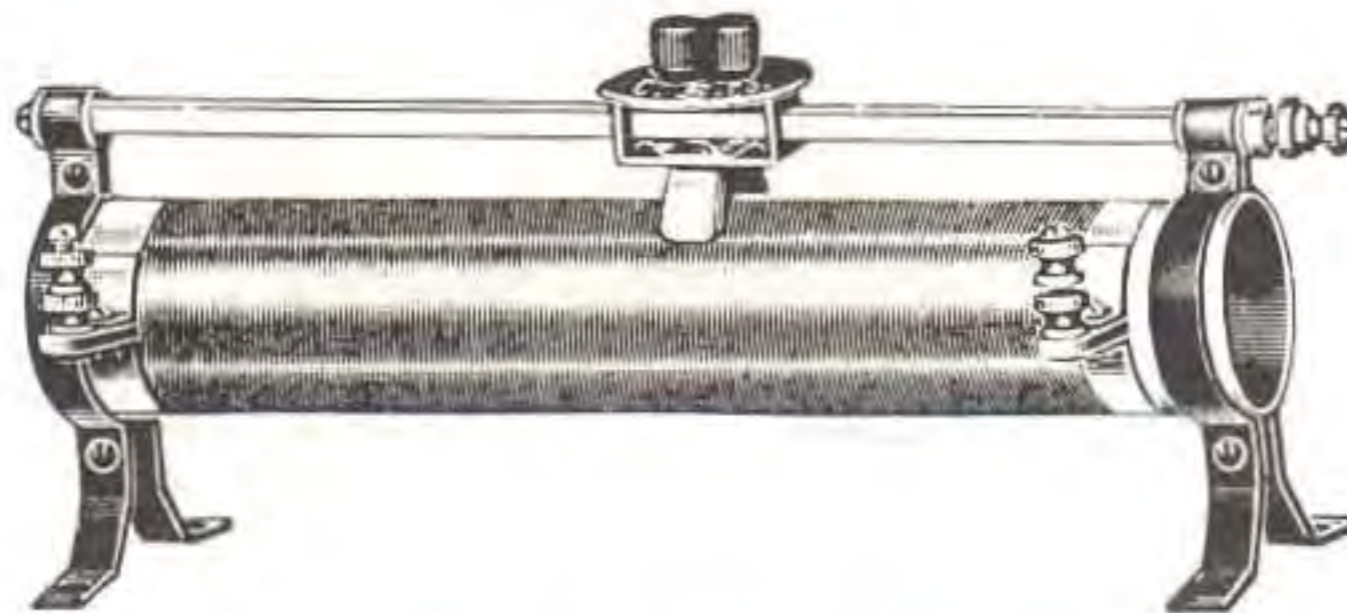

**Fig. 1-1** Early 20th century slide-wire rheostat  
(Central Scientific Co.)



tricity could be produced by chemical means (c. 1800) they probably gave little thought to in-circuit variability of parameters. However, by the time Ohm presented his famous law in 1827, the first crude variable resistive devices were no doubt being constructed by physicists in all parts of the world. Though its origin can be debated, one certainty is that early forms of variable resistance devices bore very slight resemblance to those available and accepted as commonplace by today's engineer. In the late 19th century, they were found only in laboratories and were large bulky instruments.

One of the earliest devices was a carbon pile shown in Fig. 1-2. Each carbon block was about two inches square and a quarter of an inch thick. An insulated tray held the blocks. Metal blocks, placed anywhere in the stack or pile, provided terminals for connection to external circuitry. Minor adjustment of resistance was accomplished by varying the mechanical pressure exerted by the clamping action of a screw going through one end of the tray and pressing on the metal block at the end of the stack. As the pressure was increased, the carbon blocks were forced closer and closer together, thus reducing

the contact resistance from one block to the next, causing the overall resistance from end to end to be decreased. Major changes of resistance could be accomplished by removing some of the carbon blocks and substituting more conductive metal blocks in their place. It was also possible to place terminal-type metal blocks at intermediate points between the ends of the stack to achieve tapping and potential divider applications. This early form, in slightly different configurations, was used for many years.

A later model (c. 1929) is shown in Fig. 1-3. This model offered many improvements over its predecessors. Improvements such as higher wattage dissipation (note cooling fins), wider adjustment range and stability of resistance at high resistance values where blocks are relatively loose.

Many sewing machine motor speed controls in the 1940's used carbon piles of half-inch discs which were only about a sixteenth of an inch thick. In this form, a mechanical linkage from a foot pedal to the pile allowed the operator to vary the pressure on the pile and hence the speed of the motor. The carbon pile is still in use today in such places as telephone circuits and experimental laboratories.

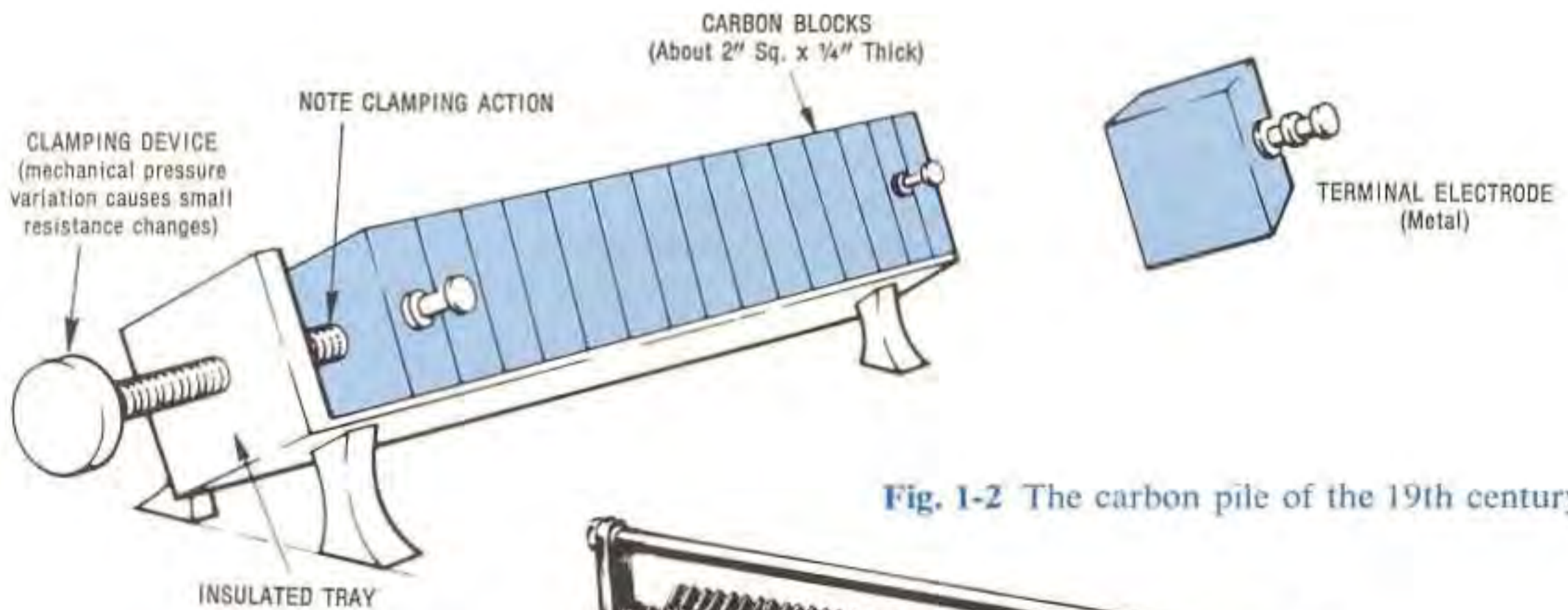

Fig. 1-2 The carbon pile of the 19th century

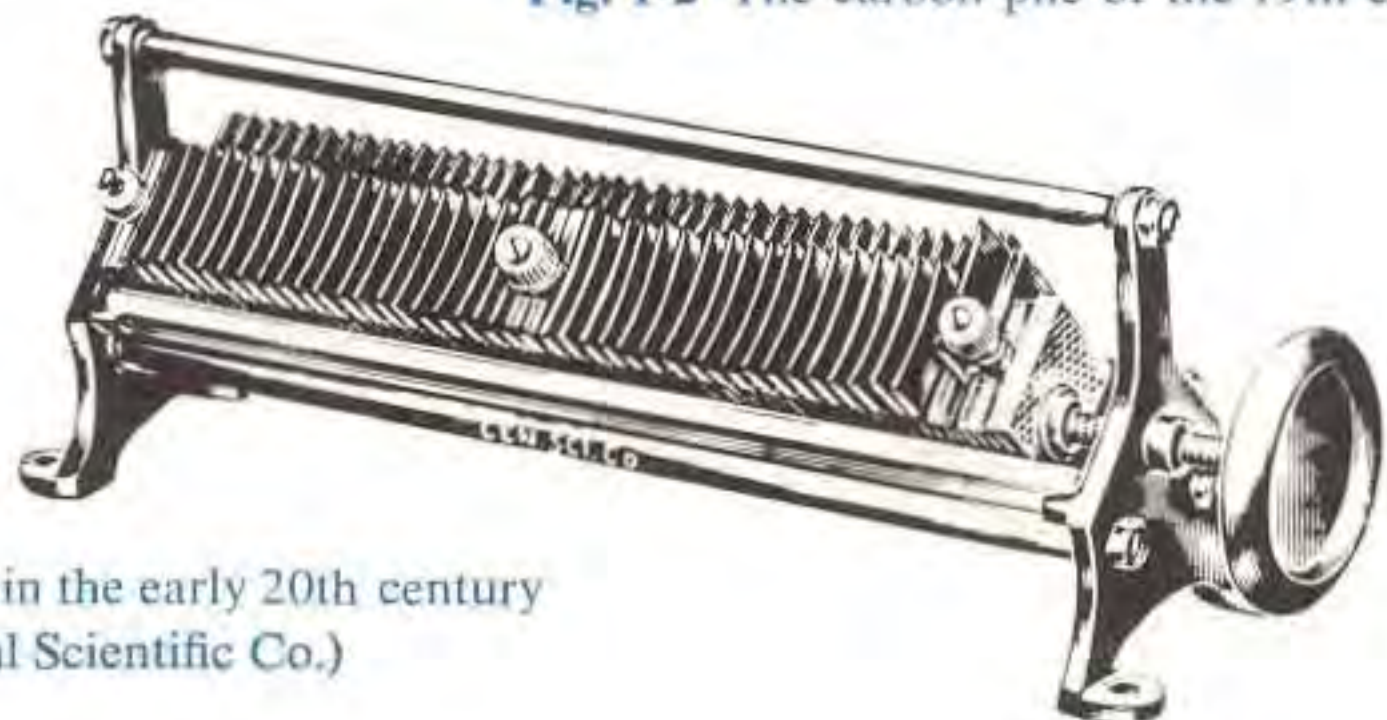

Fig. 1-3 The carbon pile in the early 20th century (Central Scientific Co.)



Another early form of variable resistance device consisted of a length of resistance wire and a sliding contact as shown in Fig. 1-4. The total resistance between A and B could be varied by choosing different types of materials for the wire or by varying the geometrical properties of the wire. It was probably in this simple configuration that early devices originally found their way into measuring instruments of the type shown in Fig. 1-5.

The purpose of this instrument was to measure unknown potentials such as  $E_x$  in Fig. 1-5. Two variable resistive devices,  $R_1$  and  $R_2$ , were

employed in this circuit. Note that a meter stick was placed adjacent to  $R_2$  and served as a scale to determine relative settings of  $R_2$ 's sliding contact. For proper operation,  $E_1$  had to be greater than  $E_2$  and  $E_2$  had to be greater than  $E_x$ . The instrument was initially calibrated by placing  $R_2$ 's sliding contact to the full scale (B) position and, with  $S_1$  in the calibrate position, was adjusted for a zero on  $M_1$  while  $S_2$  was being depressed. What was taking place during the calibration procedure was that the voltage across  $R_2$  imposed by  $E_1$  was being made equal to the voltage across  $R_2$  imposed by  $E_2$ . When this condition was achieved no current flowed in the

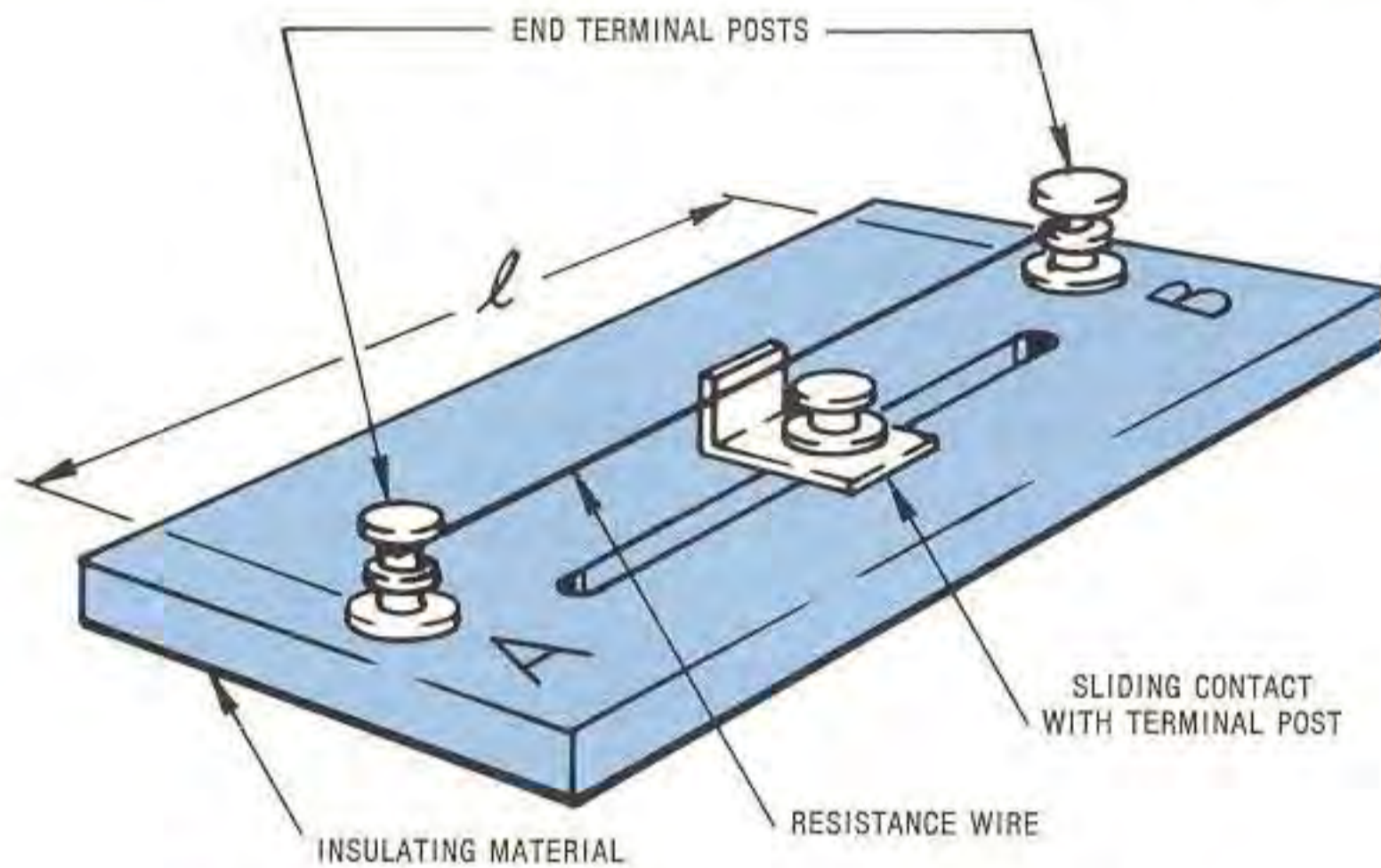

Fig. 1-4 Simple slide-wire variable resistance device

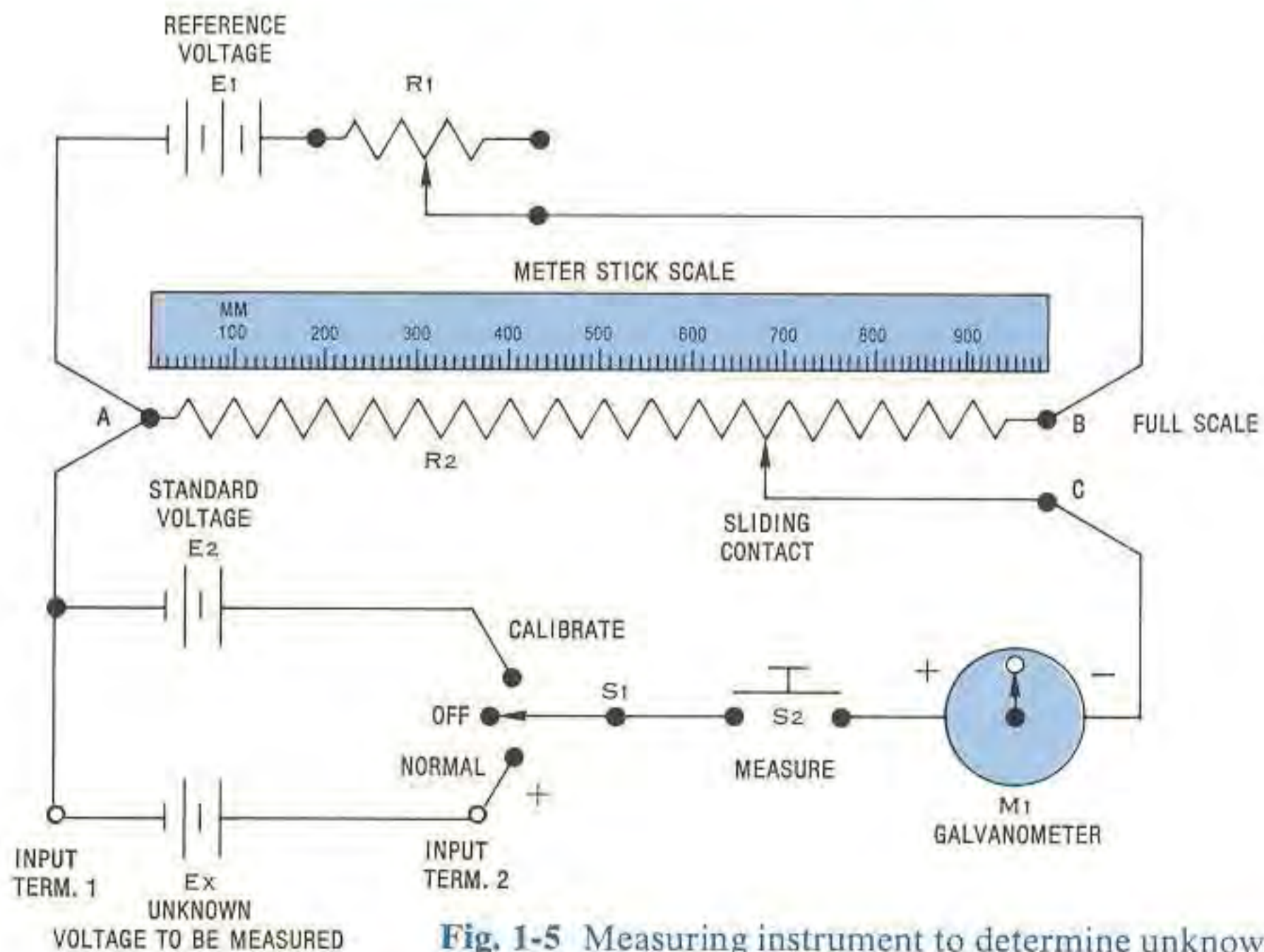

Fig. 1-5 Measuring instrument to determine unknown voltage



section of the circuit containing M1 and its reading was therefore zero. After the calibration sequence, S1 was placed in the normal position and the circuit was then ready to measure unknown voltages of magnitudes less than E2. If an unknown voltage was present at the input terminals 1 and 2, then M1 would deflect either plus or minus with respect to the calibrated zero.

If the deflection was in the positive direction, then the sliding contact of R2 could be moved from terminal B toward A until M1 returned to zero. The value of E<sub>x</sub> was then calculated from:

$$E_x = \frac{E_2 R_{AC}}{R_{T2}}$$

where E2 was the standard voltage (volts), R<sub>T2</sub>' was the total resistance of R2 (ohms) and R<sub>AC</sub> was that portion of R2's resistance between terminals A and C (ohms).

The unknown voltage could have been determined using the meter stick. If the sliding contact was at 700 mm after the circuit was nulled with the unknown voltage in the circuit, the ratio of R<sub>AC</sub> to R<sub>T2</sub>' is:

$$\frac{R_{AC}}{R_{T2}} = \frac{7}{10} = .7 \text{ and}$$

$$E_x = .7 E_2$$

An even simpler method would have been to calibrate the meter stick in volts and read the unknown voltages directly.

If the galvanometer deflection was in the negative direction, this indicated that E<sub>x</sub> was larger than E2 and therefore was beyond the measuring capability of the instrument. This circuit has been greatly simplified, but there is little doubt that due to this type of application in a *potential measuring meter*, the variable resistive device became universally known as the potentiometer.

In the electronics industry today, the term potentiometer has come to mean a component which provides a variable tap along a resistance by some mechanical movement rather than an entire measurement system. However, the basic potentiometer configuration described by Fig. 1-5 is still in use today but utilizes a spiral or helix of linear resistance wire in order to increase its practical length and thus its range and accuracy. Fig. 1-6 is a photograph of a modern commercial instrument using this approach.

Problems of getting enough resistance in a practical amount of space led an inventor named George Little to develop and patent what he called an "Improvement in Rheostats or Resistance Coils" in 1871. This was a structure in which insulated resistance wire was wound around an insulated tube or mandrel in a tight helix as shown by the copy of his patent drawing in Fig. 1-7. The moving slider made contact with the resistance wire along a path where the insulation had been buffed off. It was probably this patent which eventually led to the style of devices previously shown in Fig. 1-1.

In 1907, H. P. MacLagan was awarded a



Fig. 1-6 Modern instrument for precision ratio measurement (Leeds & Northrup)



(50.)

GEORGE LITTLE.

Improvement in Rheostats or Resistance Coils.

No. 122,267.

*Fig 2.*

Patented Dec. 26, 1871.

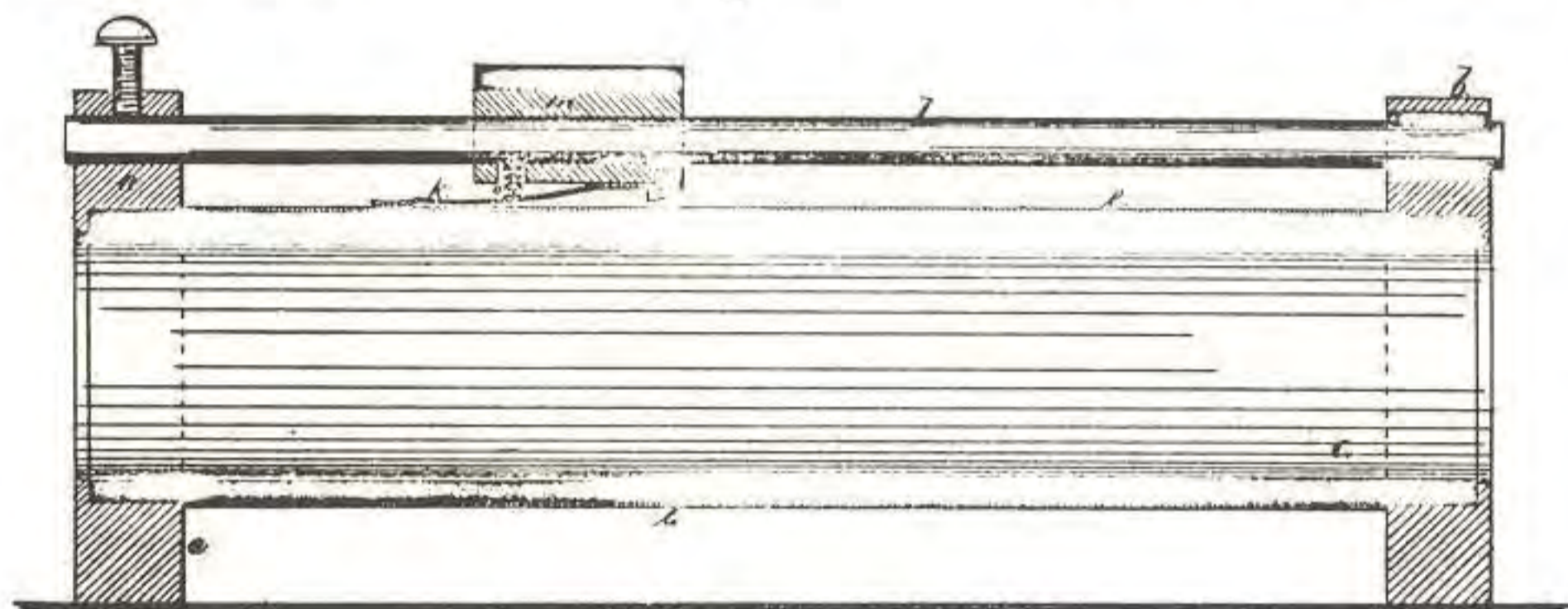

*Fig 1.*

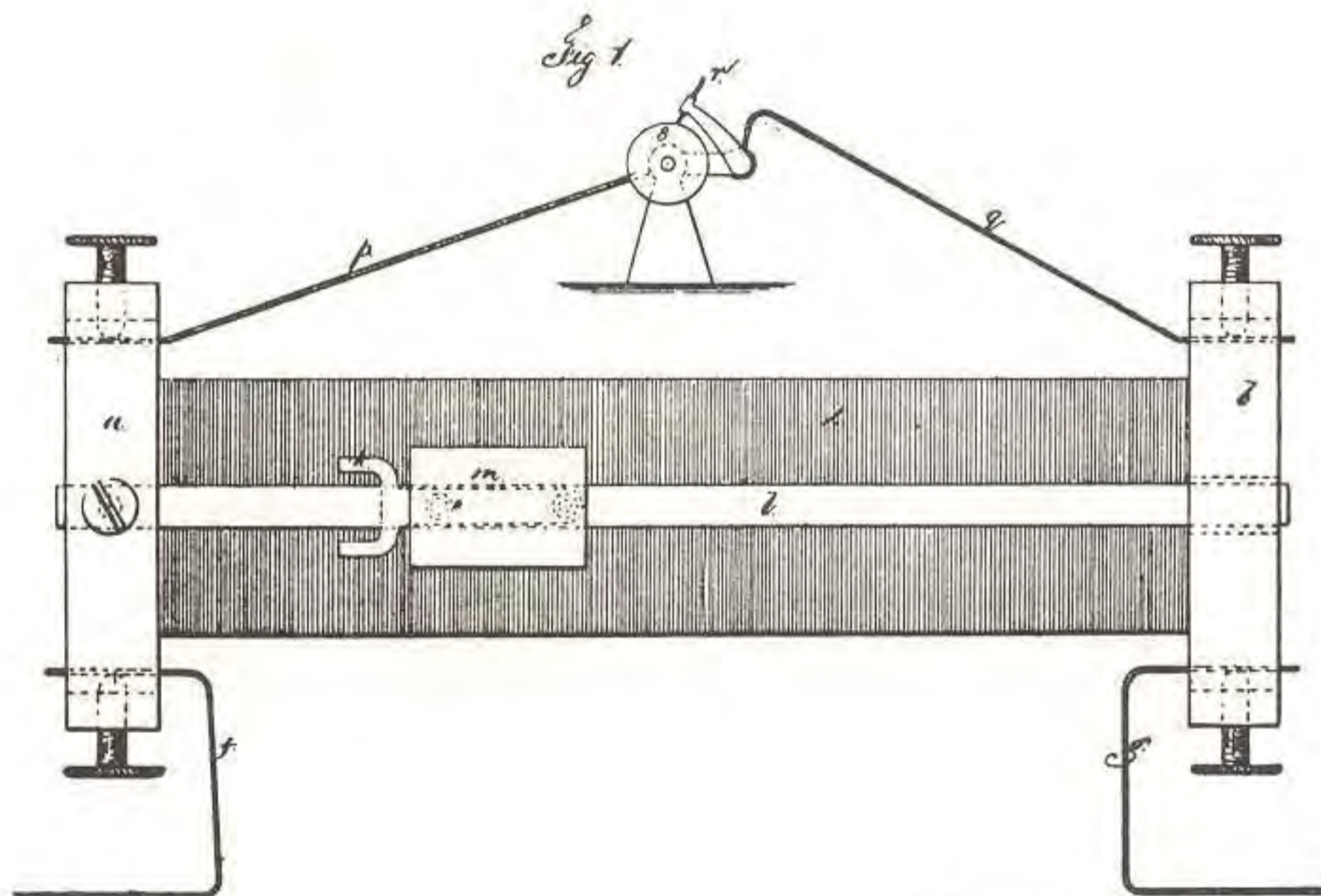

Witnesses

*Geo. D. Walker*  
*Geo. E. Parckenup*

*George Little*  
*per Lemuel W. Serrell*  
*att'y.*

Fig. 1-7 A patent drawing for a device invented over 100 years ago



patent for a rotary rheostat. Fig. 1-8 is a copy of his patent drawing. He had wound the resistance wire around a thin fibreboard card and then formed the assembly into a circle. A wiper, attached to a center post, made contact with the resistance wire on the edge of the card.

The radio era (1920-1940) created a demand for smaller components. Of course, the potentiometer was no exception and the need grew for smaller potentiometers to be used in applications such as volume controls. Resistance materials of wire and carbon were used with the carbon devices proving to be more easily produced in large quantities. The general requirements for the radios of that period were not at all stringent and the carbon volume control became common.

Electronic applications grew by leaps and bounds during World War II, and so did the need for more and better variable resistance devices to permit control, adjustment, and calibration. Components manufacturers strived to improve their products and lower their cost. Of significant note was the development of the first commercially successful 10-turn precision potentiometer by Arnold O. Beckman. He filed patent applications for improvements over earlier efforts in October of 1945. A drawing from the resulting patent is shown in Fig. 1-9.

The post-war years saw the commercializing of television and growth in the commercial aircraft industry. Airborne electronics applications, as well as other critical weight-space needs made size a critical factor.

In May, 1952, Marlan E. Bourns developed a highly practical miniature adjustment potentiometer for applications where infrequent control adjustment was needed. He had combined the advancing technologies of plastic molding and precision potentiometer fabrication and provided the designer with a small adjustment potentiometer with outstanding electrical performance. A copy of his patent drawing is shown in Fig. 1-10.

As the demand for small adjustment devices increased, other manufacturers began to produce similar units. Since the introduction of the miniature adjustment potentiometer, many improvements have been made, yielding better and better performance at lower and lower costs. Fig. 1-11 is a condensed portrayal of adjustment potentiometers available today.

Many of the improvements in the precision potentiometer development came about as a result of their increasing use in analog computers

as well as in more complex and precise servo systems. Again and again, potentiometer manufacturers have improved their products to meet the needs of the designers in a continuing process of development.

## PRACTICAL DEVELOPMENT OF THE POTENTIOMETER

Let's consider some of the practical factors in building potentiometers. Assume, for a moment, that the potentiometer as you know it does not exist. Then you will proceed to develop it, guided by a high degree of prior knowledge. Initially, you recognize that you need some form of component resistor which has a variable tap whose position can be changed by mechanical motion.

As a start, stretch a piece of uninsulated resistance wire between two terminals. You can now fashion some type of clamp to make contact with the wire at any point between the terminals. The result might look very similar to the device in Figure 1-4 shown previously.

A fundamental equation describing the total resistance,  $R_T$ , from A to B is:

$$R_T = \frac{\rho l}{S}$$

Where  $\rho$  is the resistivity, given in ohms - centimeters. The length,  $l$ , of the wire is measured in centimeters and  $S$  is the cross sectional area of the wire expressed in square centimeters. The calculated  $R_T$  will then be given in ohms.

Thus, in order to get a larger value of resistance, either the resistivity or length must be increased, or you might choose to decrease the area. The choices of resistivity are somewhat limited, and increasing the length very quickly produces a bulky and quite impractical component. Using a smaller wire likewise has its problems of increased fragility and difficulty in making proper terminations and contact with the sliding tap.

One way to increase the length of the wire in a practical manner is to wind it around some form of insulating material or mandrel. This could take the form of a fibreboard tube as shown in Fig. 1-12 or a flatter strip of material as shown in Fig. 1-13. A study of either of these potentiometer configurations reveals several possible problems.



No. 870,042.

PATENTED NOV. 5, 1907.

H. P. MacLAGAN,  
RESISTANCE ADJUSTING DEVICE.  
APPLICATION FILED OCT. 11, 1906.

Fig. 1.

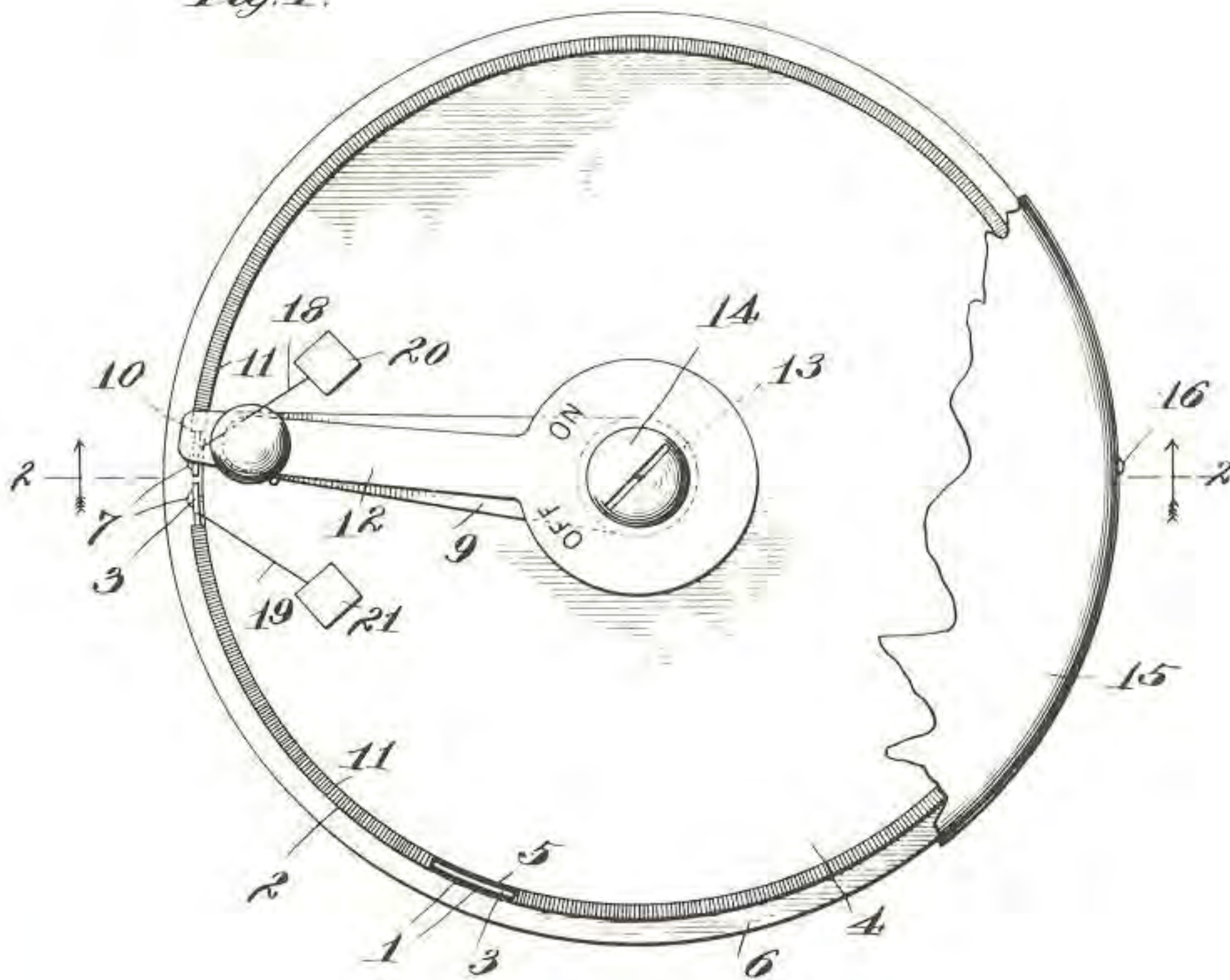
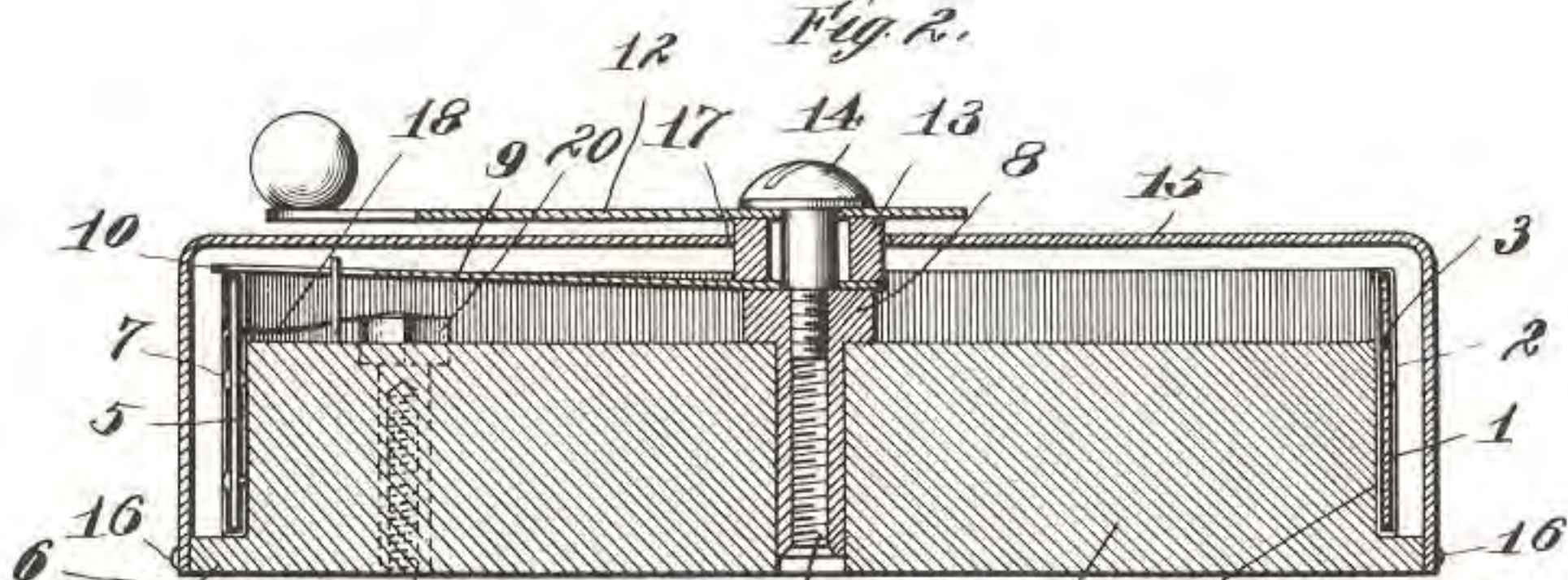

Fig. 2.



Witnesses: R.R.  
G. A. Paubuschmidt.  
Charles J. Schmidt.

Inventor:  
Hector P. Mac Lagan,  
By Charles A. Brown  
Atty

Fig. 1-8 A patent drawing from the early 1900's



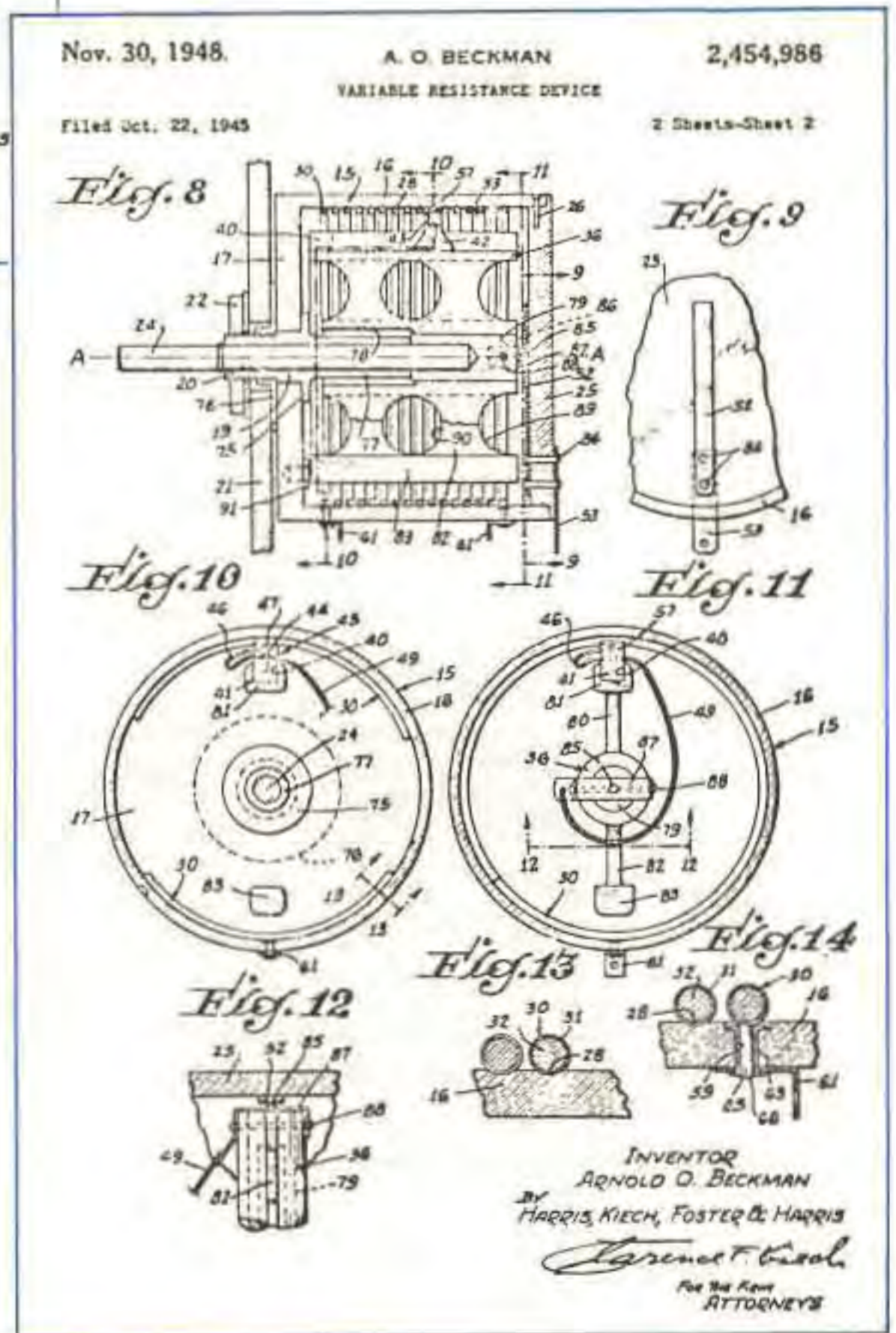
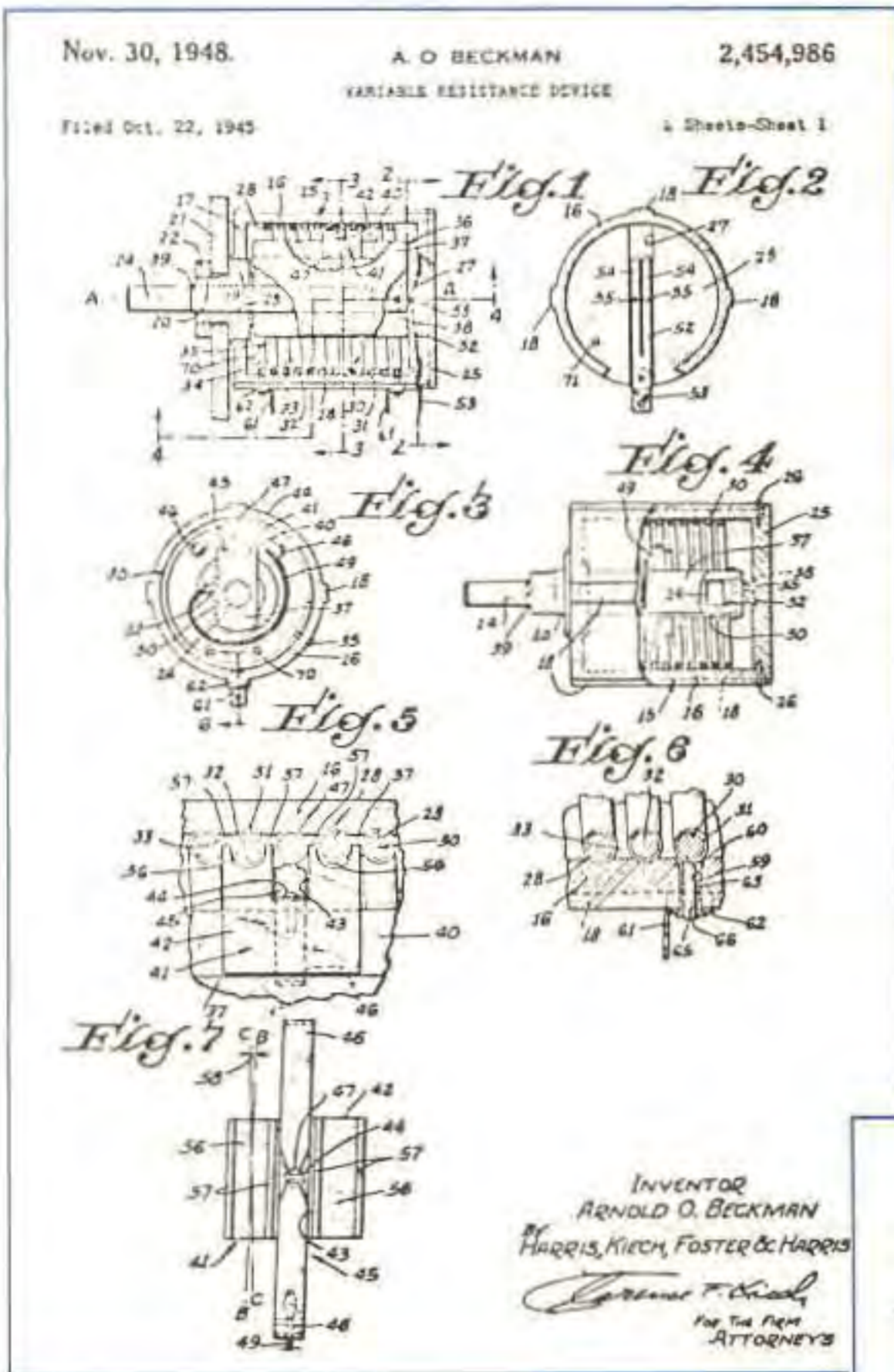

Fig. 1-9 A. O. Beckman's patent drawing for a 10-turn precision potentiometer. Filed in 1945.



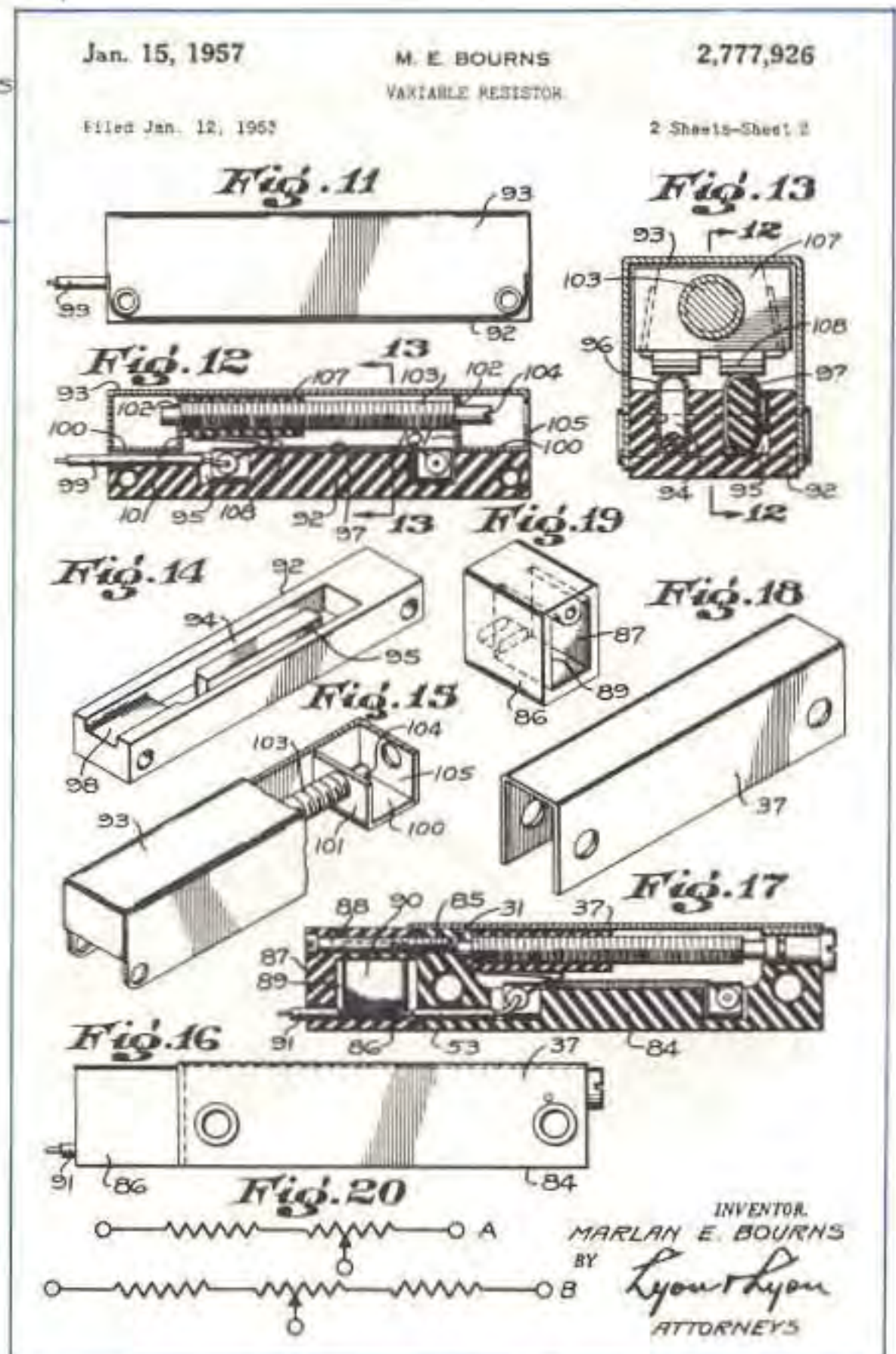
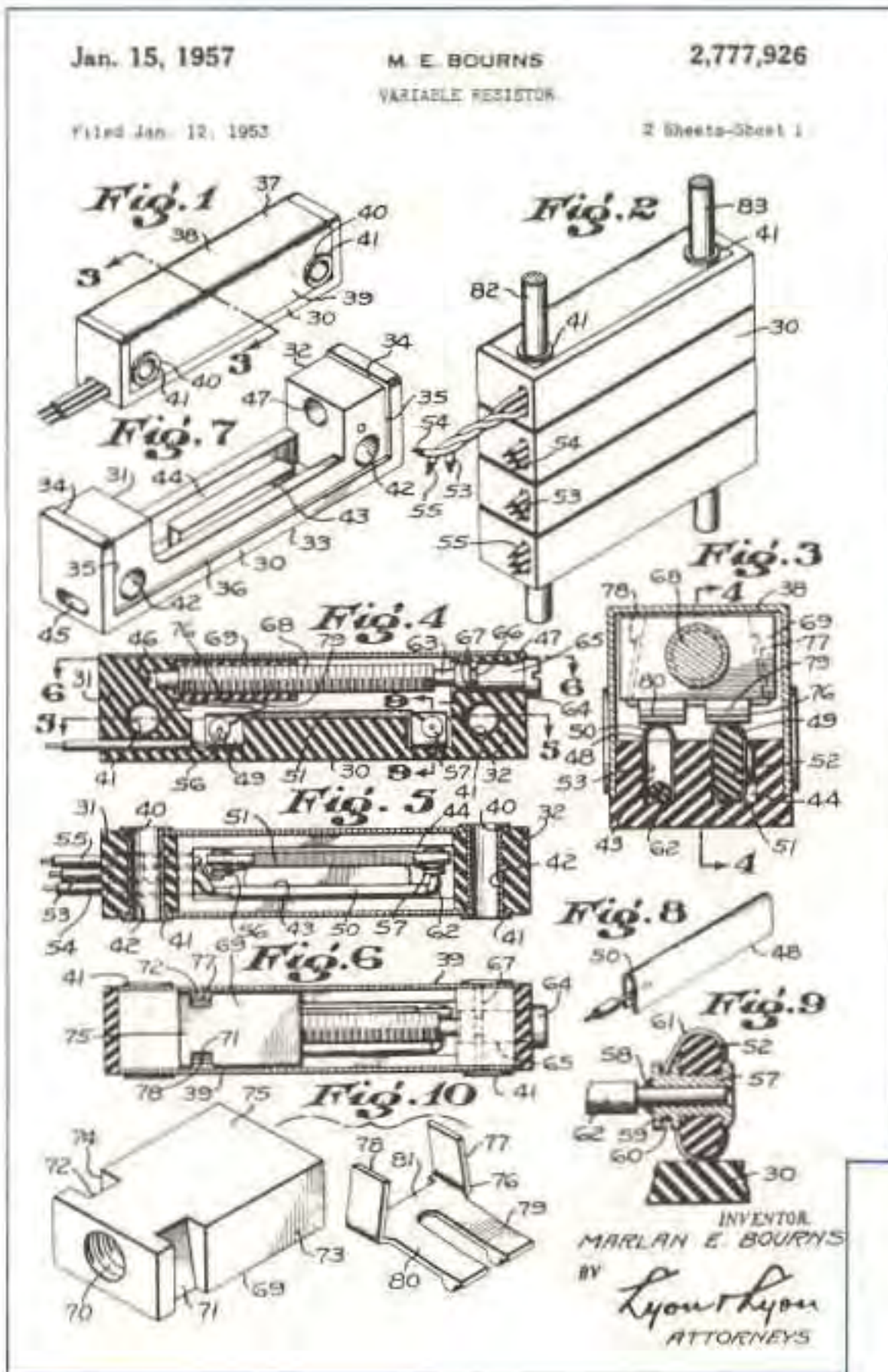

Fig. 1-10 Marlan E. Bourns' patent drawing for a practical miniature adjustment potentiometer. Filed in 1953.



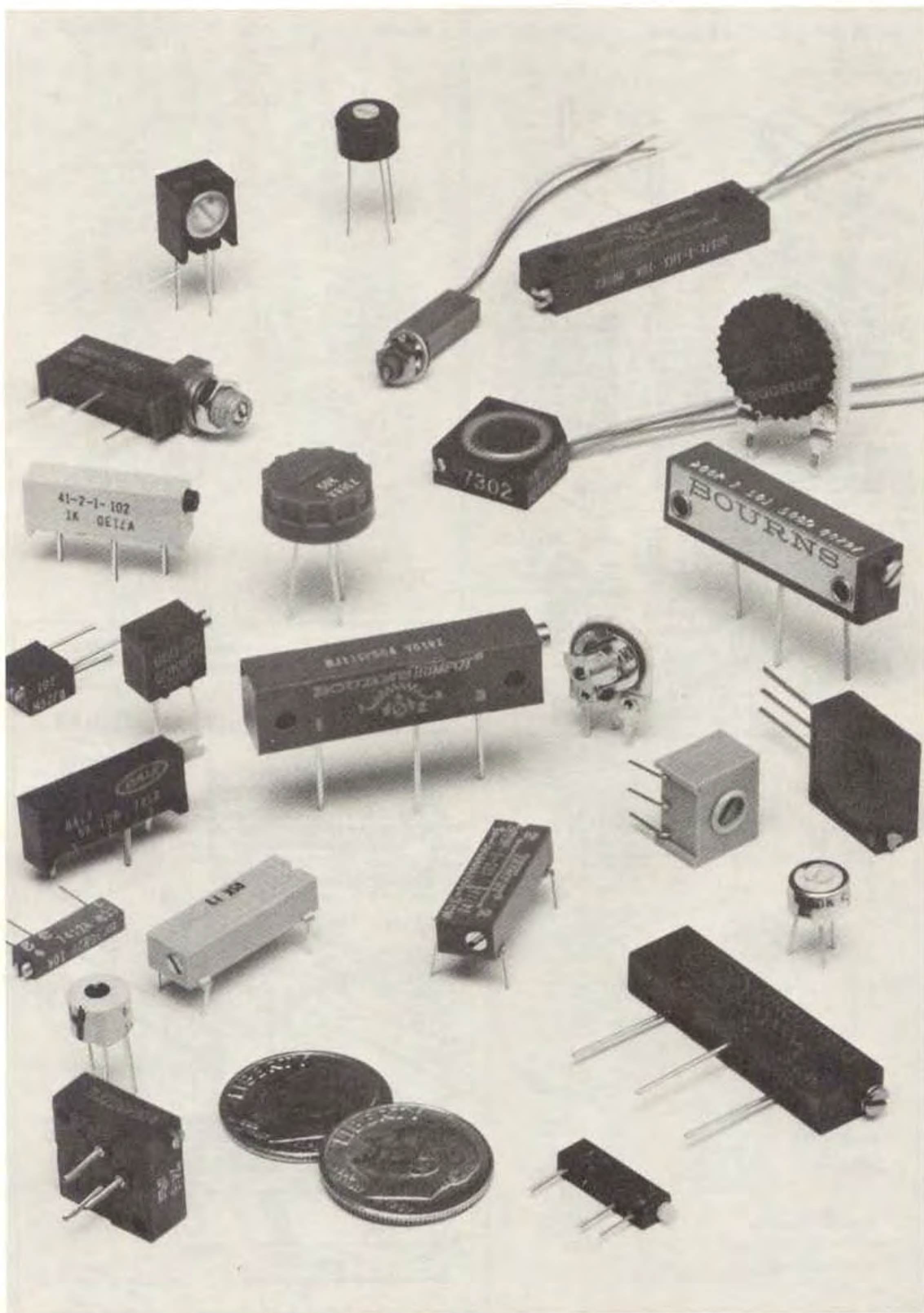
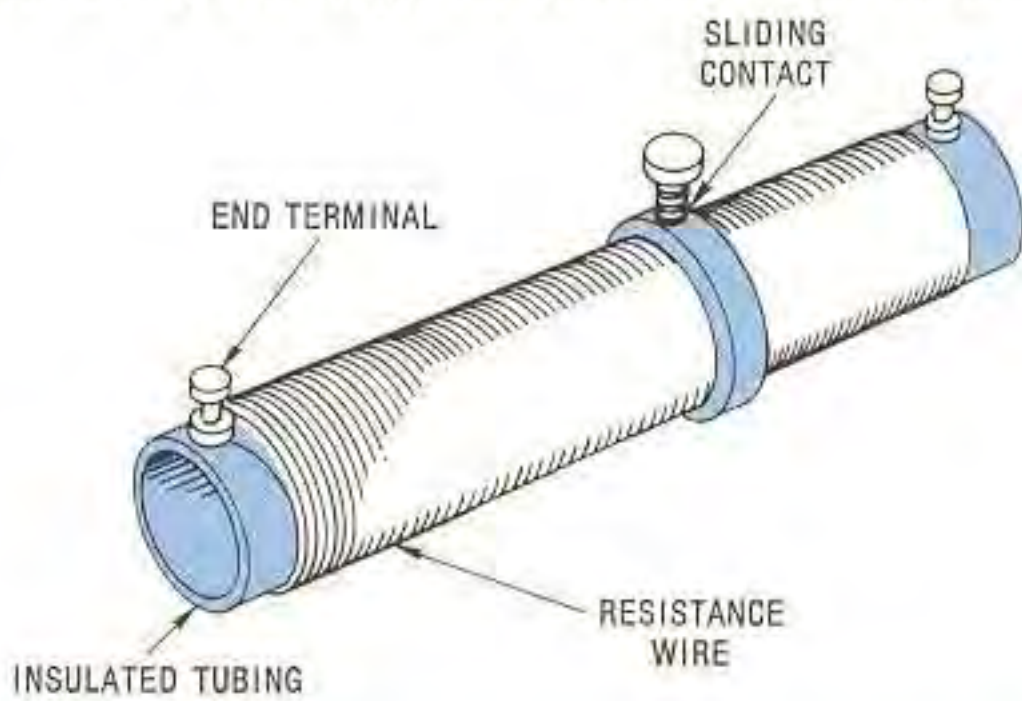

Fig. 1-11 Adjustment potentiometers of today



First of all, the turns of wire need to be close together to prevent any discontinuities with the sliding contact. This presents another problem of possible shorting from one turn to the next. You can use a very light insulation on the wire such that adjacent turns will not short together but which may be easily removed in the path of the sliding contact.

Secondly, unlike our previous straight wire potentiometer, this new version will not permit a smooth and continuous change in the tap position. Now, the tap will electrically jump from one turn to the next with no positions allowed in between. The larger the cross section of the man-



**Fig. 1-12** Winding resistance wire on insulated tube allows longer wire in a practical package

drel the greater the resistance, but the greater the jumps will be.

In addition, if you want the relative position of the sliding contact to produce an equivalent change in the effective electrical position of the sliding tap, then you must be very careful to wind the coil of resistance wire uniformly in both tension and spacing throughout the entire length. End terminations must be made and positioned very carefully. You normally would want the extreme mechanical positions to correspond to the electrical ends of the total resistance.

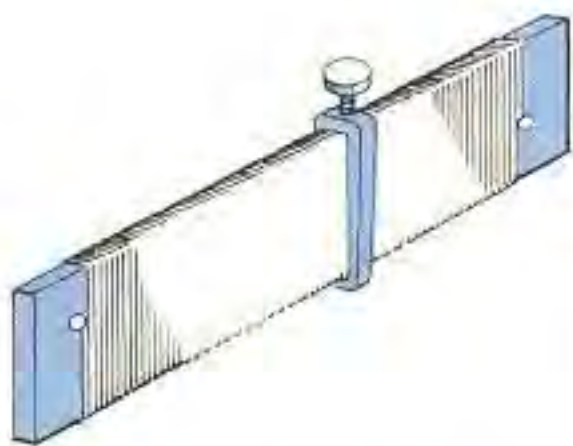

**Fig. 1-13** A flat mandrel could be used

If the flat mandrel of Fig. 1-13 is curved as shown in Fig. 1-14, two benefits result. First, you can have a longer effective mandrel with less bulk. Then you can easily pivot the sliding contact from a post in the center. Attaching the slider arm to a shaft will allow convenient rotary motion to control the position of the arm.

You may curve the round mandrel potentiometer of Fig. 1-12, if the mandrel's diameter is kept relatively small. A round mandrel is more easily wound and a small size also means that the jumps or steps in resistance as a sliding contact moves from one turn to the next will be less. Furthermore, the length of the mandrel may be curved in the form of a helix as shown in Fig. 1-15. This will allow a long mandrel to be con-

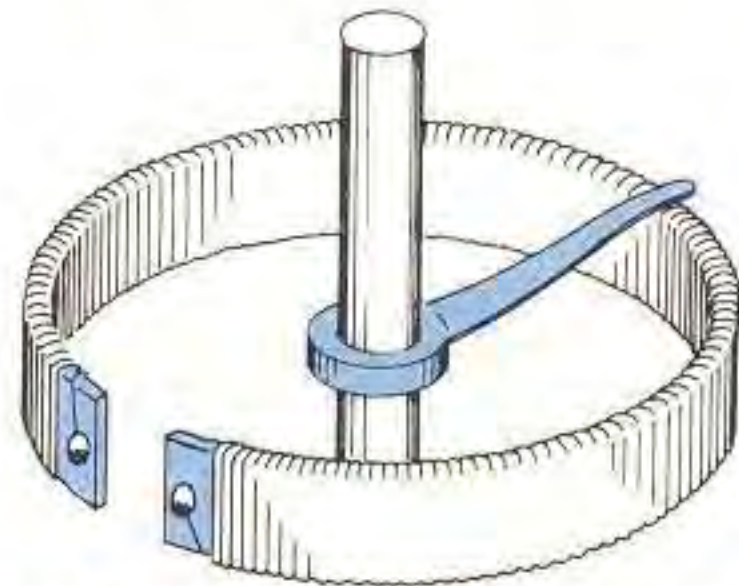

**Fig. 1-14** Curved mandrel saves space and allows rotary control

finned to a relatively small space. The helical configuration requires more complicated mechanics to control the position of the slider arm, but the overall performance makes it worth the trouble.

So far, in this imaginary development of potentiometers, only wire has been considered for the resistance element. Other materials are usable that offer advantages but not without introducing some new problems.

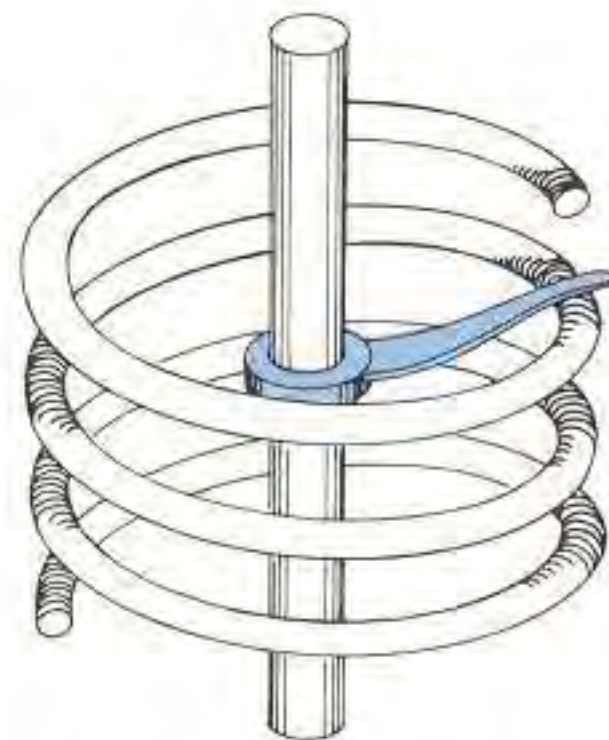
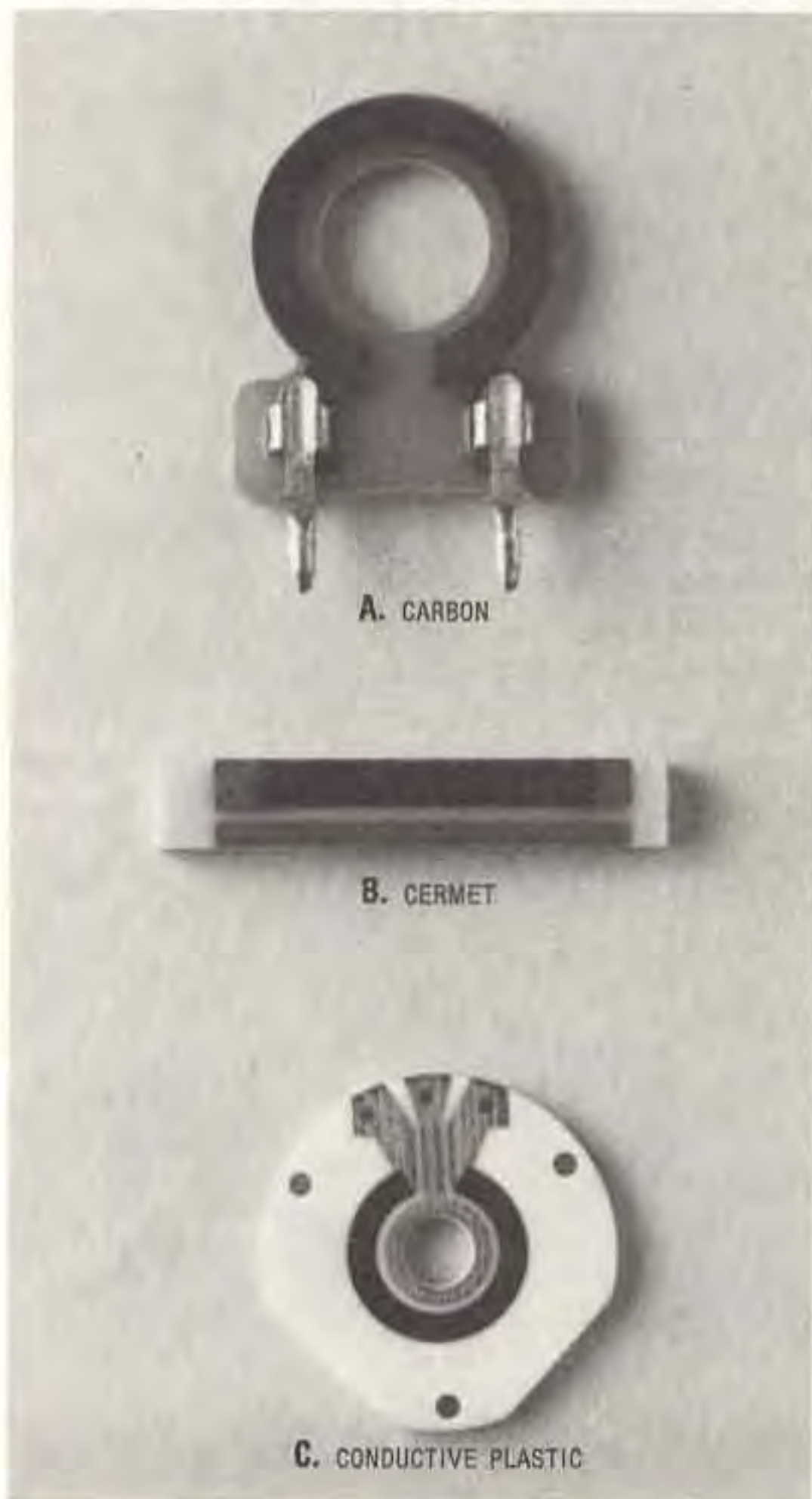

**Fig. 1-15** Shaping mandrel into helix puts long length in small space



A resistive element made from a carbon composition material as illustrated in Fig. 1-16A could have a much higher resistance than is possible with wire. In addition, since the element is not coiled, you no longer have to tolerate jumps in the output as you did with wirewound potentiometers. A third benefit comes from the greater ease (less friction) with which the slider can move over the composition element and the corresponding reduced wear which results. A catastrophic failure can occur in the wirewound potentiometer when a single turn is worn through or otherwise broken, but a composition element can continue to function in reduced performance even though extremely worn. Other types of composition elements are shown in Fig. 1-16B and 1-16C.

If you carefully test the composition potentiometer and compare its performance with that

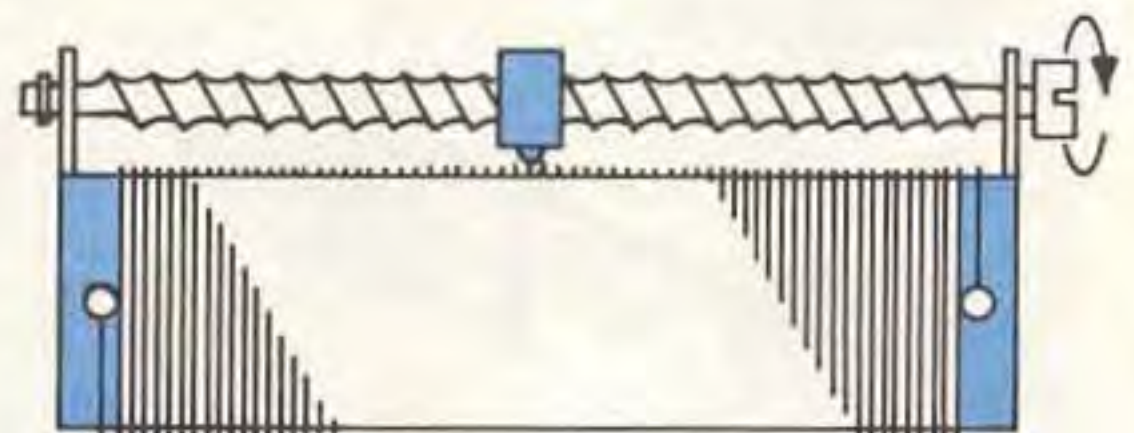

**Fig. 1-16** Resistive elements of composition materials

of the wirewound versions, you will find that there are several new problems. All of these relate to the properties and nature of carbon compositions. The overall resistance will not be as stable with time and temperature. You may notice that it is even more difficult to get a perfectly uniform change in electrical output of the sliding tap with variation in mechanical position. Terminations are more difficult to make with the composition element. Although potentiometer manufacturers do form single turn units and even helical structures using mandrels coated with a composition material, it is a more complex and critical process than in the case of wirewound devices.

A special problem occurs in developing a variable resistance device for use in a particular application where one of the prime considerations is its setability or adjustability (ease and precision with which output can be set on desired value). In the simplest design configurations, you may find it somewhat difficult to set the potentiometer slider at some exact spot. If you have a unit with linear travel of the sliding contact as in Fig. 1-13, consider adding a lead screw arrangement such as shown in Fig. 1-17. Now, many turns of the lead screw will be required to cause the sliding contact to go from one end to the other. This mechanical advantage means that it will be easier to set the movable contact to any point along the resistive element. Be careful that no excessive play or mechanical backlash exists in the mechanism. This would make it impossible to instantly back the slider up, for a very small increment, if you turn the lead screw past the intended location.

A similar mechanical improvement to the rotary configuration of Fig. 1-14 would be the addition of some form of worm gear. The adjusting screw would be the driving gear and produce a smaller rotation of the main driven gear which would be attached to the shaft controlling the



**Fig. 1-17** A simple lead screw aids setability



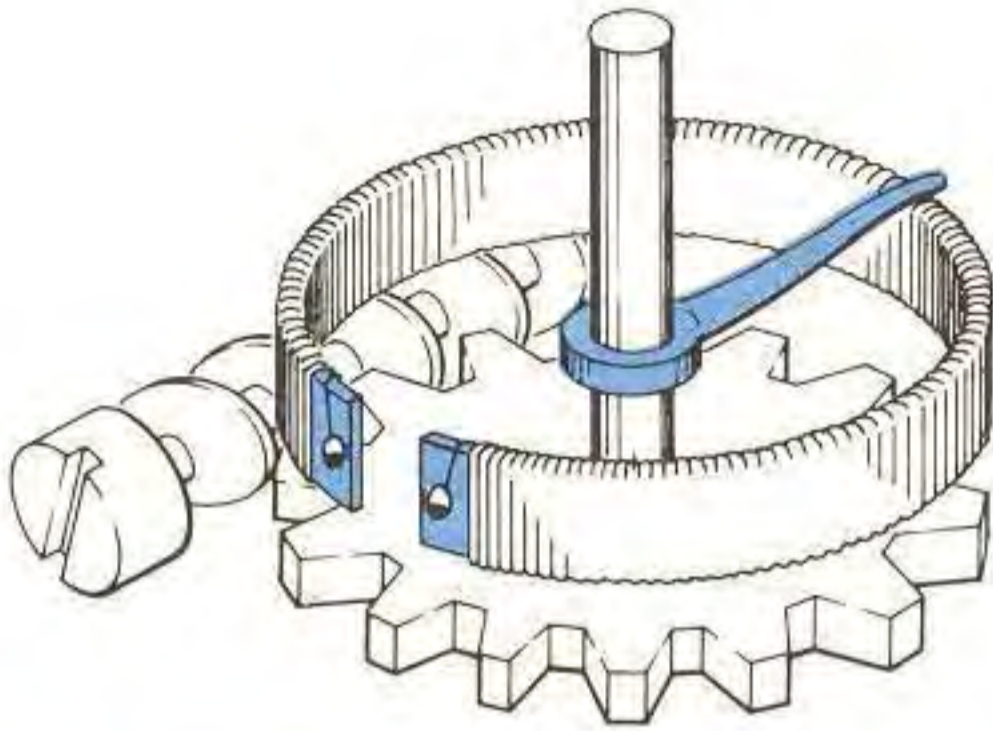
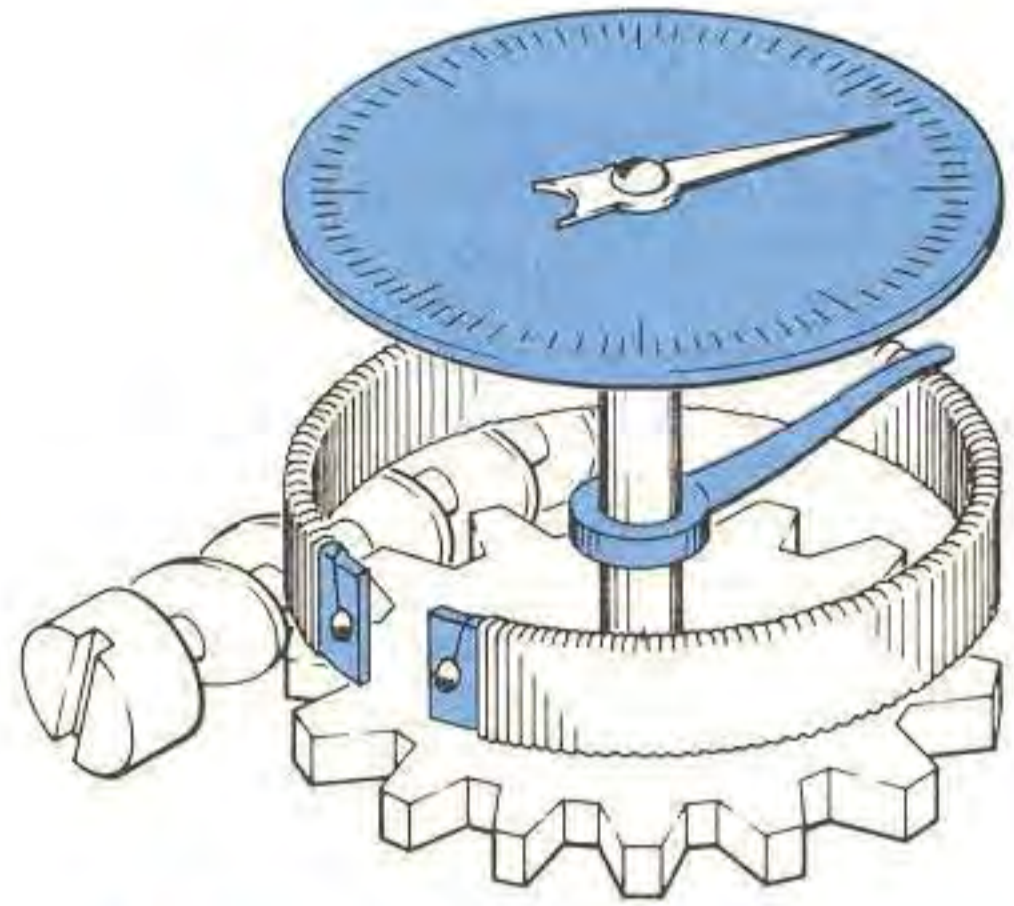

**Fig. 1-18** A worm gear may be added to the rotary pot

sliding contact arm. The end result might look something like that shown in Fig. 1-18.

Further applications of variable resistive devices might require that the relative position of the sliding contact be known to a degree of accuracy better than a simple direct visual estimation. For example, a potentiometer may be used to control the speed of a motor at a location remote from the control center. Some form of indicator is required on the potentiometer so that motor speeds are predictable and accurately repeatable.

The meter stick served as an indicator in the potentiometer circuit arrangement of Fig. 1-5. The scale could have been calibrated in any units desired depending on the particular application involved. A simple indicator for the rotary unit of Fig. 1-18 can be constructed by attaching an appropriately divided scale to the



**Fig. 1-19** A simple sliding contact position indicating device

unit and connecting a pointer to the shaft driving the sliding contact. The result is shown in Fig. 1-19.

Simple dials will not provide adequate accuracy of setability for all applications. More complex mechanisms, such as shown in Fig. 1-20, have been developed by potentiometer manufacturers to meet the constantly increasing demands of the electronics industry.

Thus, in something over 100 years, resistance adjusting devices have evolved from bulky crude rheostats to a whole family of diverse products. Their use has spread from experimental laboratory to sophisticated electronics and critical servomechanisms and even inexpensive consumer items. In fact, most segments of the economy are served by variable resistor devices. Information applied from the following pages will help them serve even more effectively.



**Fig. 1-20** Accurate devices for sliding contact position indication



## GENERIC NAMES AND TRADEMARKS

Many common terms used to name variable resistive devices have evolved over the years. Some of them relate to certain applications and will be used in that context later. The more common generic names are listed in Fig. 1-21.

Commercialization of potentiometers has resulted in a proliferation of trademarks in the United States and foreign countries. Manufacturers frequently register their trademarks in the United States Patent Office and identify them with a ® or a statement that they are registered.

Trademarks serve to assure the buyer that certain quality characteristics inherent with a

specific manufacturer have been built into the product. It is the reputation behind the trademark that makes it meaningful to the buyer and the user.

Well-known trademarks are usually policed with zeal by their owners. This helps assure that they are not misused and do not fall into common or generic usage which would weaken their value to the public and the manufacturer. The general rule is that a manufacturer's trademark should be used as a *modifier* of the generic name for a product of the manufacturer. For example: TRIMPOT® potentiometers, not trimpots.

adjustable resistors	precisions
adjustment potentiometers	rheostats
adjustments	servo-potentiometers
attenuators	servo-pots
controls	transducer
feedback resistors	trimming potentiometers
gain controls	trimmers
impedance compensators	tweakers
level controls	variable resistive devices
potentiometers	variable resistors
pots	volume controls
precision potentiometers	

Fig. 1-21 Generic names





*"I often say that when you can measure what you are speaking about, and express it in numbers, you know something about it; but when you cannot express it in numbers, your knowledge is of a meagre and unsatisfactory kind; it may be the beginning of knowledge, but you have scarcely, in your thoughts, advanced to the stage of Science, whatever the matter may be."*

*Lord Kelvin*

## INTRODUCTION

Electrical parameters are those characteristics used to describe the function and performance of the variable resistive device as a component. These parameters can be demonstrated using simple electronic measurement methods.

Understanding these terms is fundamental to effective communication of application needs and cost-effective product selection. A thorough understanding of this material will aid in interpreting potentiometer manufacturer's data sheets and thus accomplish one of the aims of this book. A summary of electrical parameters is shown in Figure 2-41 for handy reference. Mechanical and environmental specifications can be found in the application chapters.

This chapter is organized for each parameter as follows:

- Definition
- Examples of typical values
- Detailed explanation of factors contributing to the parameter
- Simple electronic circuit to demonstrate the parameter (not for inspection or quality control)

After reading this chapter, further insight into these parameters can be gained by reading the industry standards reproduced in Appendix

I. The Variable Resistive Components Institute (VRCI) has published these standards for precision and trimming potentiometers. Their purpose is to establish improved communication between manufacturer and user. VRCI test circuits are regarded as the industry's standard, while the ones in this chapter are only study aids.

Figure 2-1 is the basic schematic of the potentiometer. This is usually used to show the device in a circuit or system.

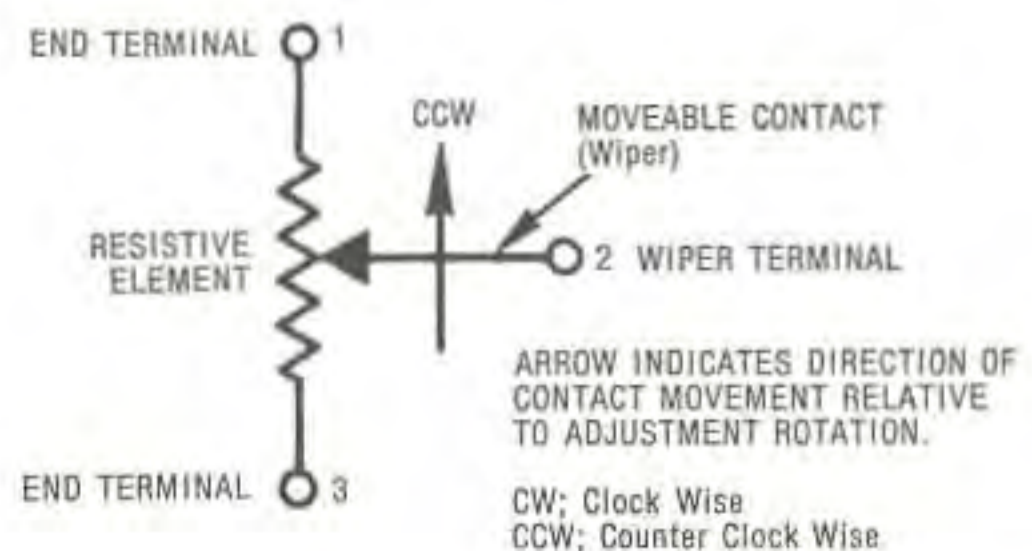

**Fig. 2-1** Fundamental schematic representation of variable resistive device



## TOTAL RESISTANCE, TR

Total resistance, TR, is a simple parameter defined as the resistance between the end terminals of a potentiometer. The end terminals are shown as 1 and 3 in Fig. 2-1.

Total resistance is always specified as a nominal value in units of ohms. A plus and minus percent tolerance from the nominal value is also specified. For example,  $10\Omega \pm 5\%$ ,  $10K\Omega \pm 10\%$ , and  $100\Omega \pm 20\%$ .

TR is always specified when defining any potentiometer. It is known by several names including: *value* of the potentiometer, *maximum resistance* or simply the *resistance*.

The major contributor to total resistance is the potentiometer's resistive element. The material and methods used to construct the element determine its resistance. The resistance of the terminals or leads of the potentiometer and the resistance of the termination junctions contribute to total resistance.

A digital ohmmeter is a convenient and accurate device for measuring TR. It is connected to the end terminals of the potentiometer as shown in Fig. 2-2. Total resistance is read directly from the display.

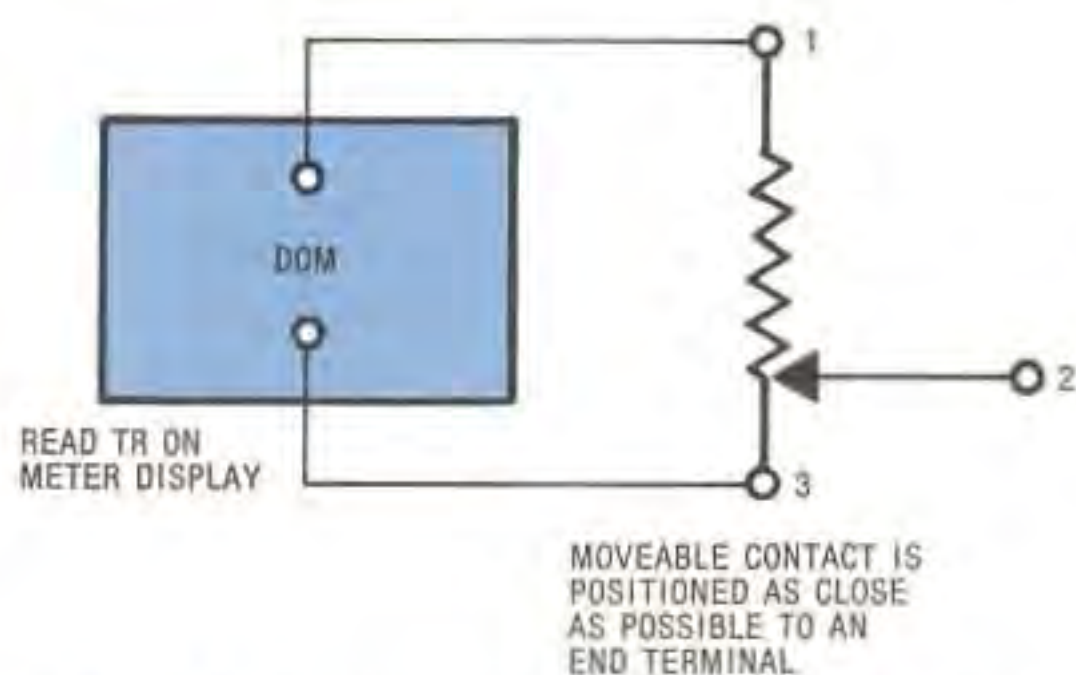

**Fig. 2-2** Fundamental measurement of total resistance

Note in Fig. 2-2 that the potentiometer's moveable contact (wiper) is positioned as close as mechanically possible to one of the unit's end terminals. If the potentiometer were a continuous rotation device, i.e. no mechanical end-stops provided, the wiper would be adjusted to a point completely off of the resistive element. These wiper positions are industry standard test conditions. They are chosen not only to minimize the wiper effect on the TR measurement but also to improve data correlation. For example, when comparing TR measurements taken at different times or from different units, it is known that the wiper was in exactly the same position during each measurement.

Industry standard test conditions specify a maximum voltage for TR measurement. This voltage restriction is necessary to limit the power dissipation in the resistive element. The heating effects of power dissipation will affect the TR measurement. By restricting the test voltage, this heating effect is minimized.

## ABSOLUTE MINIMUM RESISTANCE, MR

Absolute minimum resistance, MR, or simply minimum resistance, is the lowest value of resistance obtainable between the wiper and either end terminal.

Minimum resistance is always specified as a maximum. This seems contradictory but the specification is a level of resistance at or *below* which the wiper can be set. For example, 0.5 ohm maximum, or 1.0% maximum, (of total resistance). The design and construction of the potentiometer determines the magnitude of MR. Contact resistance, materials, and termination junctions all may contribute to MR.

For many potentiometers, MR is found when the moveable contact is set at the mechanical end stop near an end terminal. Other designs will exhibit minimum resistance when the wiper is slightly remote from the end stop. Fig. 2-3A shows an example of the latter. Depending on potentiometer design, a termination tab is clipped on or welded to the end of the resistive element. Many turns of resistance wire are bridged by this tab so that resistance within this area is low. The chance of potentiometer failure, due to one wire breaking or loosening, is minimized resulting in higher reliability and longer life. Note that some of the turns between the end-stop and the termination point are not bridged by the termination tab.

As the moveable contact is positioned along the resistive element, the minimum resistance will be achieved when the contact is closest to the termination tab, position A in Fig. 2-3A. If the contact is moved away from position A, in either direction, the resistance between the moveable contact terminal and the reference end terminal will increase. The curve in Fig. 2-3B together with the schematic of Fig. 2-3C serve to further clarify this important parameter.

A wirewound resistive element was chosen in the previous paragraph to demonstrate minimum resistance. Wirewound units often use the construction technique described. However, the occurrence of absolute minimum resistance at a point remote from the end stop is not exclusive to wirewound construction. Some potentiometers utilizing non-wirewound elements will have



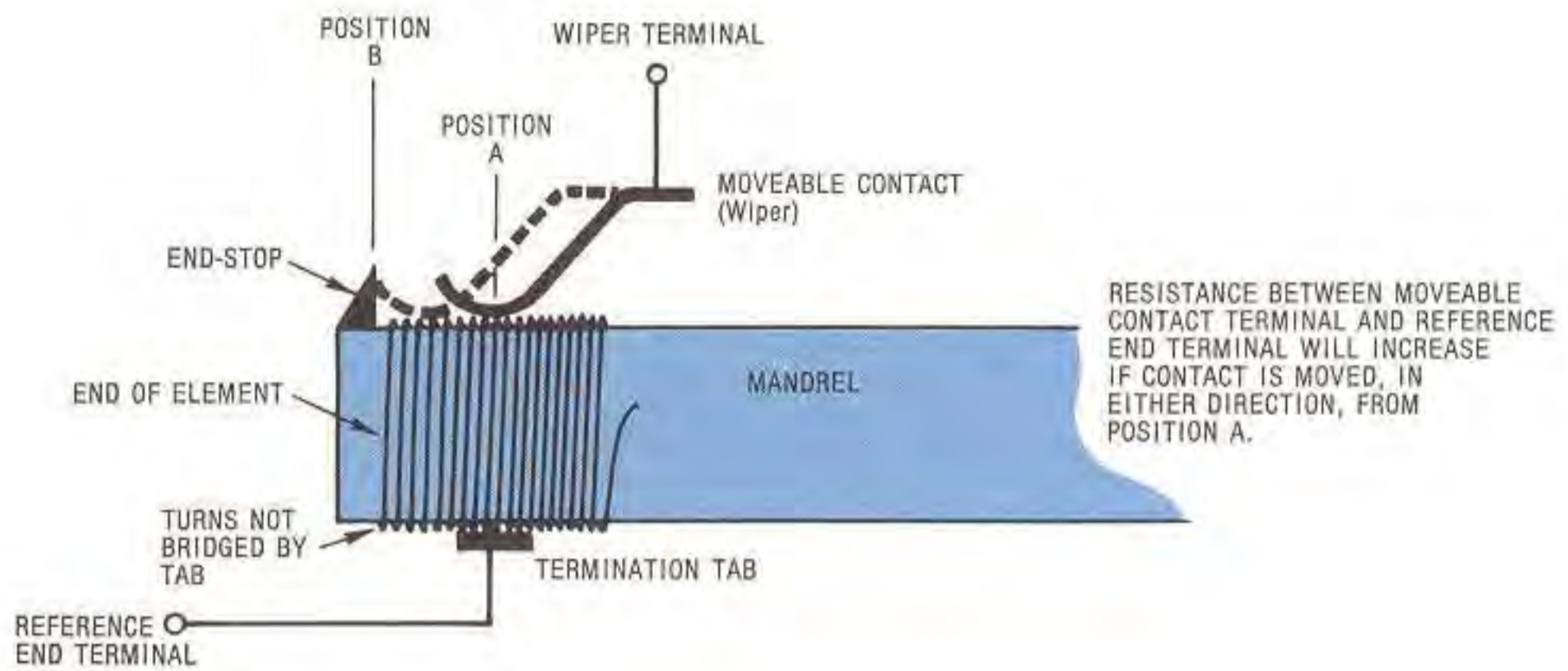

A. WIREWOUND ELEMENT AND TERMINATION

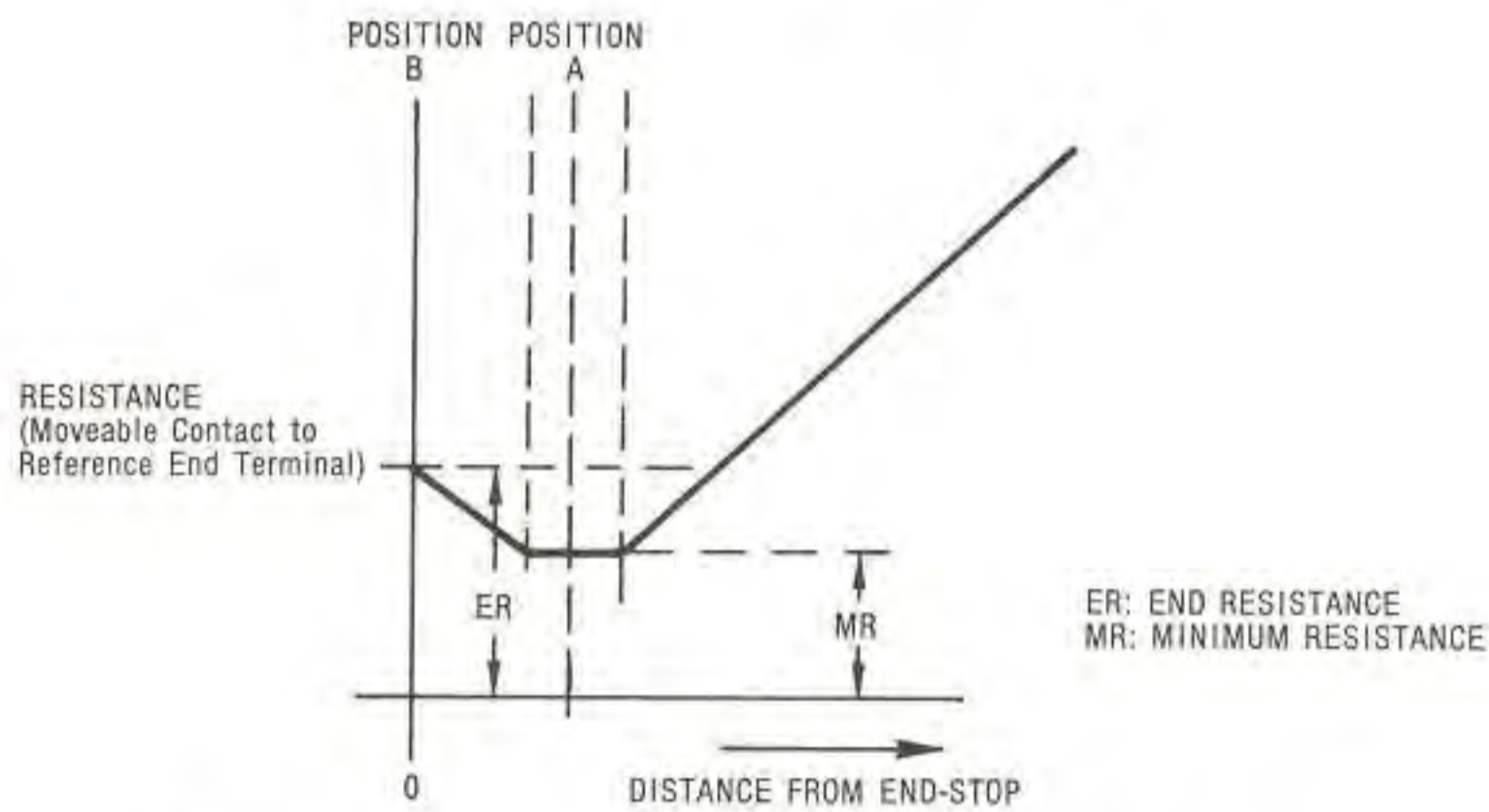

B. DISTANCE FROM END OF ELEMENT vs. RESISTANCE BETWEEN MOVEABLE CONTACT AND REFERENCE END TERMINAL.

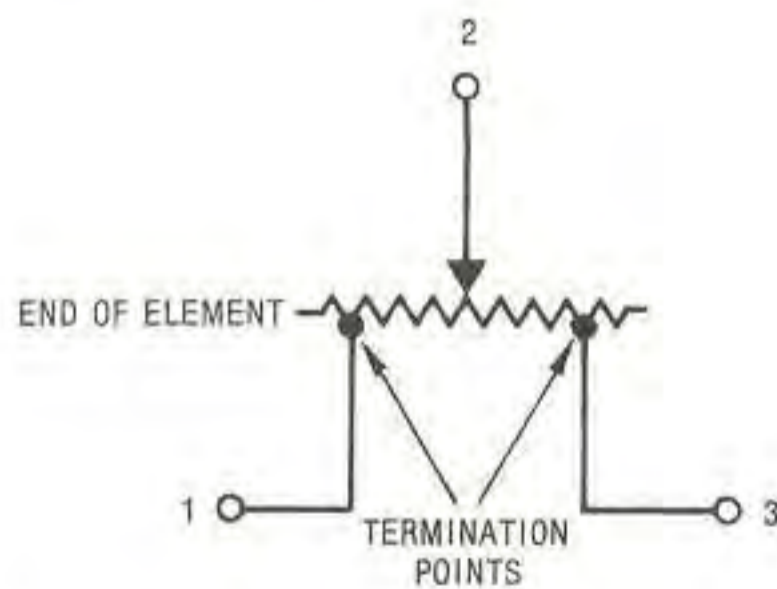

C. SCHEMATIC DRAWN TO ILLUSTRATE TERMINATION POSITION RELATIVE TO ELEMENT END.

Fig. 2-3 Illustration of minimum resistance and end resistance



their minimum resistance at a point different from the end stop position.

Fig. 2-4 is one possible MR demonstration circuit. With a hookup as shown, the wiper is positioned to a point that gives the minimum resistance reading on a digital ohmmeter.

When measuring MR, the test current must be no greater than the maximum wiper current rating of the potentiometer. High current can cause errors and will damage the potentiometer.

**Caution: Never use a conventional volt-ohm-milliammeter, VOM, to measure resistance parameters of a potentiometer.**

For the minimum resistance condition the wiper is near one end terminal. Little or no resistance is in the test circuit. In this case, overheating and burn-out can occur even at a low voltage.

Since MR is specified as a maximum, production testing can use pass-fail instrumentation. Industry standard test conditions require a special wiper positioning device for fast and accurate adjustment. See Fig. 2-5.

### END RESISTANCE, ER

End resistance, ER, is the resistance measured between the wiper and a reference end terminal when the contact is positioned against the adjacent end stop. See position B in Fig. 2-3A and 2-3B.

End resistance and minimum resistance are sometimes confused. This is because in many

potentiometers the two parameters are, in fact, identical values obtained with the moveable contact in the same position. The only reason for having two parameters relates to the construction technique, which may cause an absolute minimum resistance separate and distinct from the end resistance. Continuous rotation devices have no end stops and therefore, ER is not specified.

End resistance is expressed in terms of a maximum ohmic value or a maximum percentage of the unit's TR. It is common practice for potentiometer manufacturers to specify MR rather than ER.

The test circuit of Fig. 2-4 is perfectly suited to end resistance measurement. All of the cautions outlined for MR measurement in the previous section apply to the measurement of ER.

### MINIMUM AND END VOLTAGE RATIOS

Because a potentiometer is sometimes used as a voltage divider, explained in Chapter 3, manufacturers' catalog sheets and components engineers will often specify a minimum voltage and/or an end voltage ratio. End voltage ratio is sometimes referred to as *end setting*. Typical values range from 0.1% to 3.0%.

Fig. 2-6 is a circuit that can be used to demonstrate a potentiometer's minimum and end voltage ratios. Current and voltage levels should only be sufficient to facilitate measurement. In no case should the devices' maximum ratings

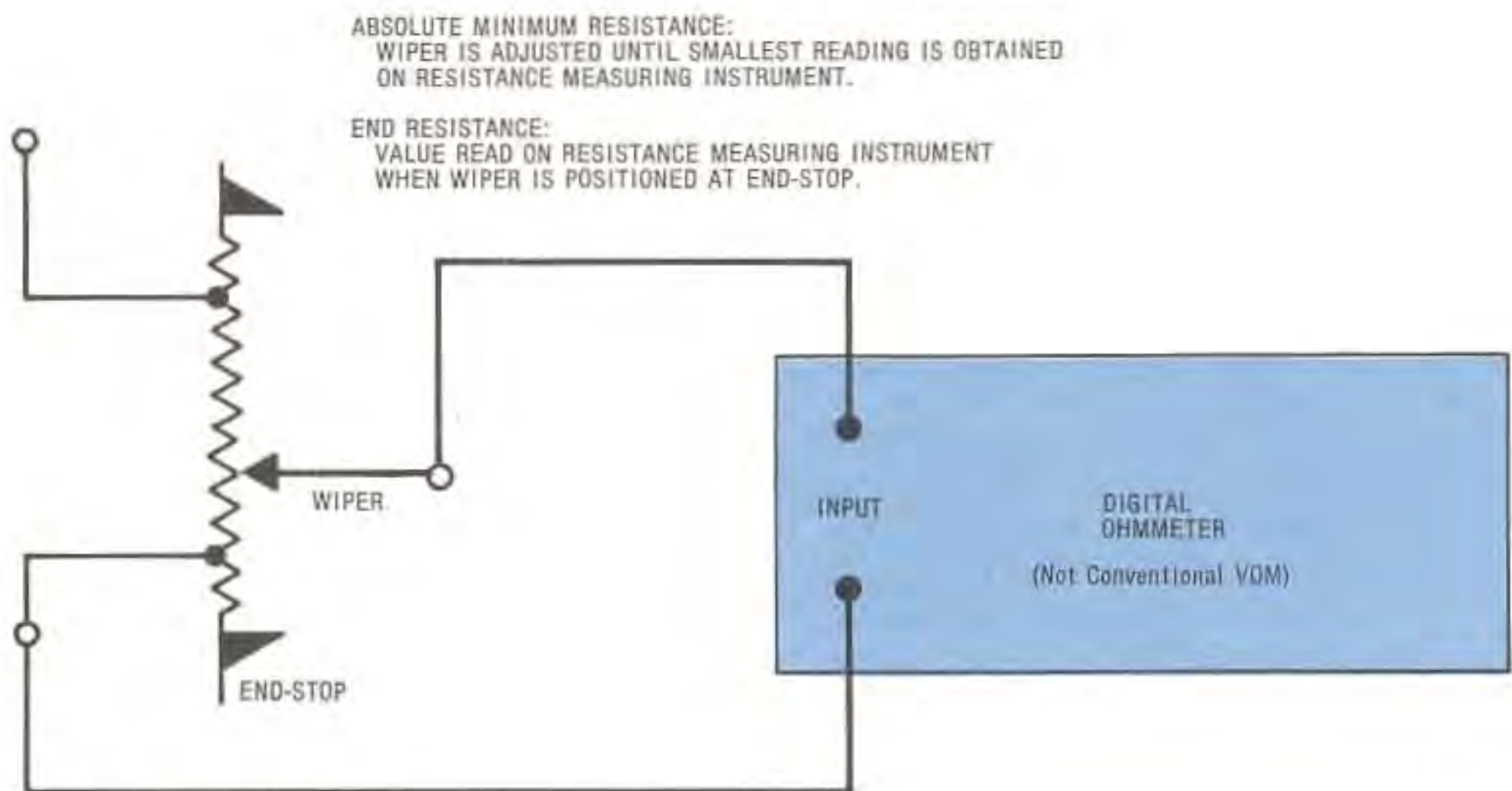

Fig. 2-4 Measurement of absolute minimum resistance and end resistance



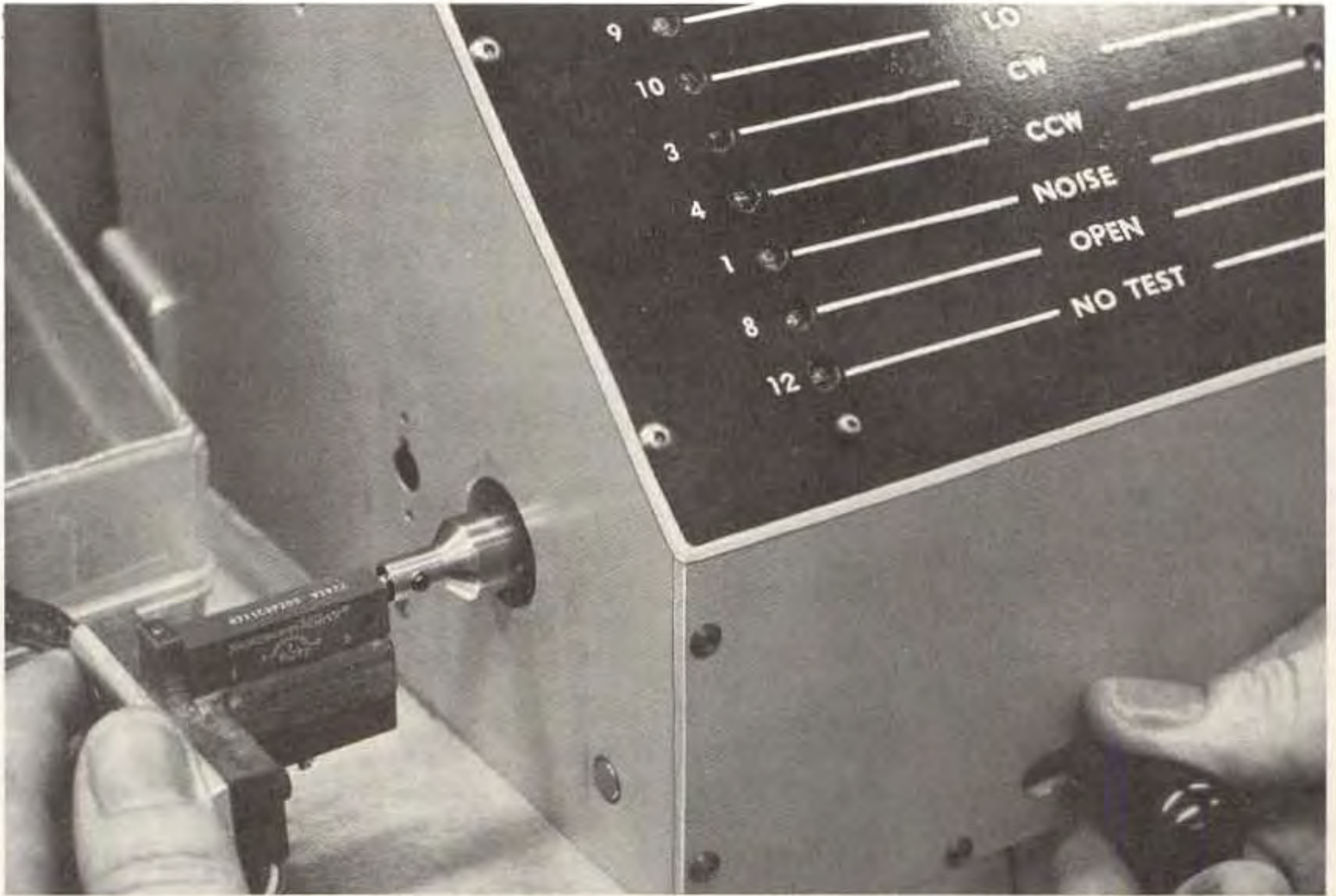
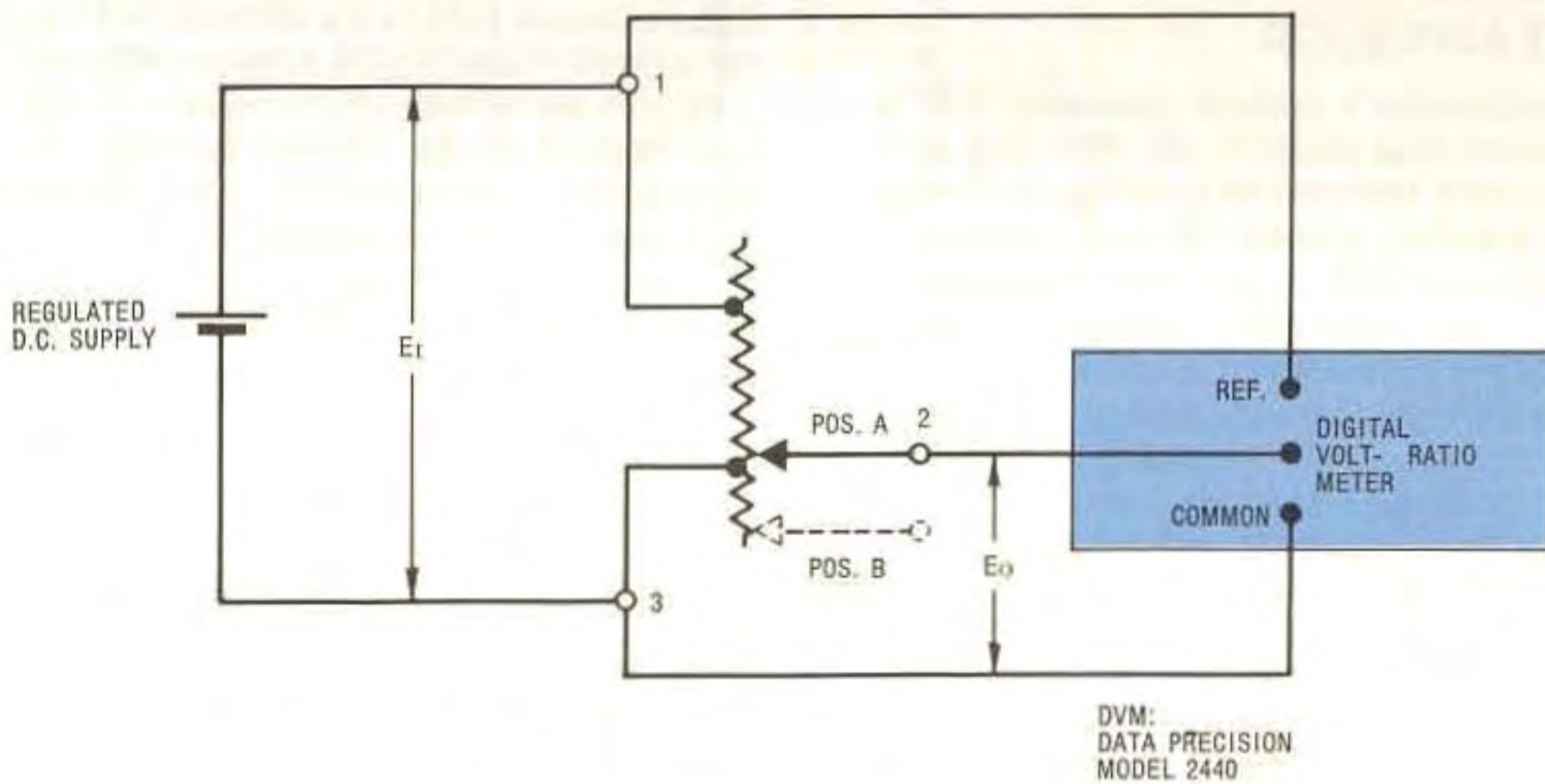

Fig. 2-5 Production testing of absolute minimum resistance



$$\text{DVM DISPLAYS READING} = \frac{E_O}{E_T} \% \text{ VOLTAGE RATIO} = \frac{E_O}{E_T} \times 100$$

Fig. 2-6 Measurement of minimum voltage ratio and end voltage ratio



be exceeded. The digital voltmeter shown in Fig. 2-6 displays the ratio of the two voltages present.

To read minimum voltage ratio, the wiper is positioned to give the smallest ratio indication on the DVM. Note that this is position A in Fig. 2-6 and it exactly corresponds to the minimum resistance wiper position. Similarly, if the wiper is positioned against the end stop of terminal 3, position B in Fig. 2-6, the DVM will display the end voltage ratio.

Some potentiometers are constructed using two parallel electrical paths. One path, the resistive element, is connected to the potentiometer's end terminals. The other path, a low resistance collector, is connected to the wiper terminal. When the moveable contact is actuated, it moves along the two paths, making contact with both. This construction and schematic are shown in Fig. 2-7.

For most potentiometer designs, the total resistance of the collector is less than one-half ohm, but it may be as high as two ohms. Assume a unit of the type shown in Fig. 2-7 is tested for its minimum or end-setting characteristics. The reading using end terminal 3 will be greater than the one using end terminal 1. This higher resistance is due to the collector's resistance in series with wiper terminal 2. This small resistance can be very significant in potentiometers of low total resistance.

Chapter 7 provides a detailed discussion of various potentiometer constructions.

## CONTACT RESISTANCE, CR

A potentiometer's contact resistance, CR, is the resistance that exists in the electrical path from the wiper terminal to its ultimate contact with the resistive element. Contact resistance can be demonstrated by a simple experiment. Make two very accurate resistance measurements, using a different end terminal as a reference for each measurement. Add the two ohmic values. Compared with a resistance measurement of the device's total resistance, it will be found that the sum of the two *parts* is greater than the *whole*. This is due to the contact resistance which imposes an additional resistance between the moveable contact and the resistive element. This experiment is accomplished in steps 1, 2, and 3 of Fig. 2-8. The equivalent schematic of CR is illustrated by Fig. 2-9.

There are two separate sources of contact resistance. The first contributor to CR is com-

pletely analogous to the contact resistance of a switch or connector. It results from the non-perfect junction of the moveable contact with the resistive element.

Surface films of metal oxides, chlorides, and sulfides along with various organic molecules, absorbed gases, and other contaminants can form on either the contact or the surface of the element. These films act as insulators and contribute to contact resistance. Just as with other forms of dry circuit contacts, this portion of CR is voltage and current sensitive. Since distribution of these contaminants is not uniform, some degree of variation in this part of contact resistance will occur. Immediate past history; that is, whether or not the wiper has been moved recently, or cycled repeatedly over the element, can cause a variation in this parameter.

The second contributor to CR results from the non-homogenous molecular structure of all matter and the well known fact that a d.c. current flowing through a material will always follow the path of least resistance. Study the exaggerated drawing of a resistive element and moveable contact in Fig. 2-10. Because of the variation in resistance of the conductive particles, the path of least resistance is irregular through the element from end terminal to end terminal.

The schematic analogy of Fig. 2-10 shows a d.c. measurement made at the wiper terminal 2 with respect to either end terminal. The measurement current will flow from the end terminal along the path of least resistance to a point opposite the moveable contact; across a relatively high resistance path to the element surface; then through the wiper circuit to wiper terminal 2.

In this simplified analysis some liberty has been taken with the physics involved but the cause-effect relationship has been maintained.

As with any resistance, the contact resistance will vary with the magnitude of the measurement current. The variation of CR with current may be different for each element material, contact material, and physical structure, particularly with regard to the force with which the contact is pressed against the resistive element. An example of current versus CR curve for a cermet resistive element is shown in Fig. 2-11. No values are assigned to the curve axis since many combinations of resistance versus current exist. The curve is typical in form, however, dropping very rapidly then flattening to a stable value within a milliamp.

Fig. 2-12 is a simple circuit for observing contact resistance. A constant current source,



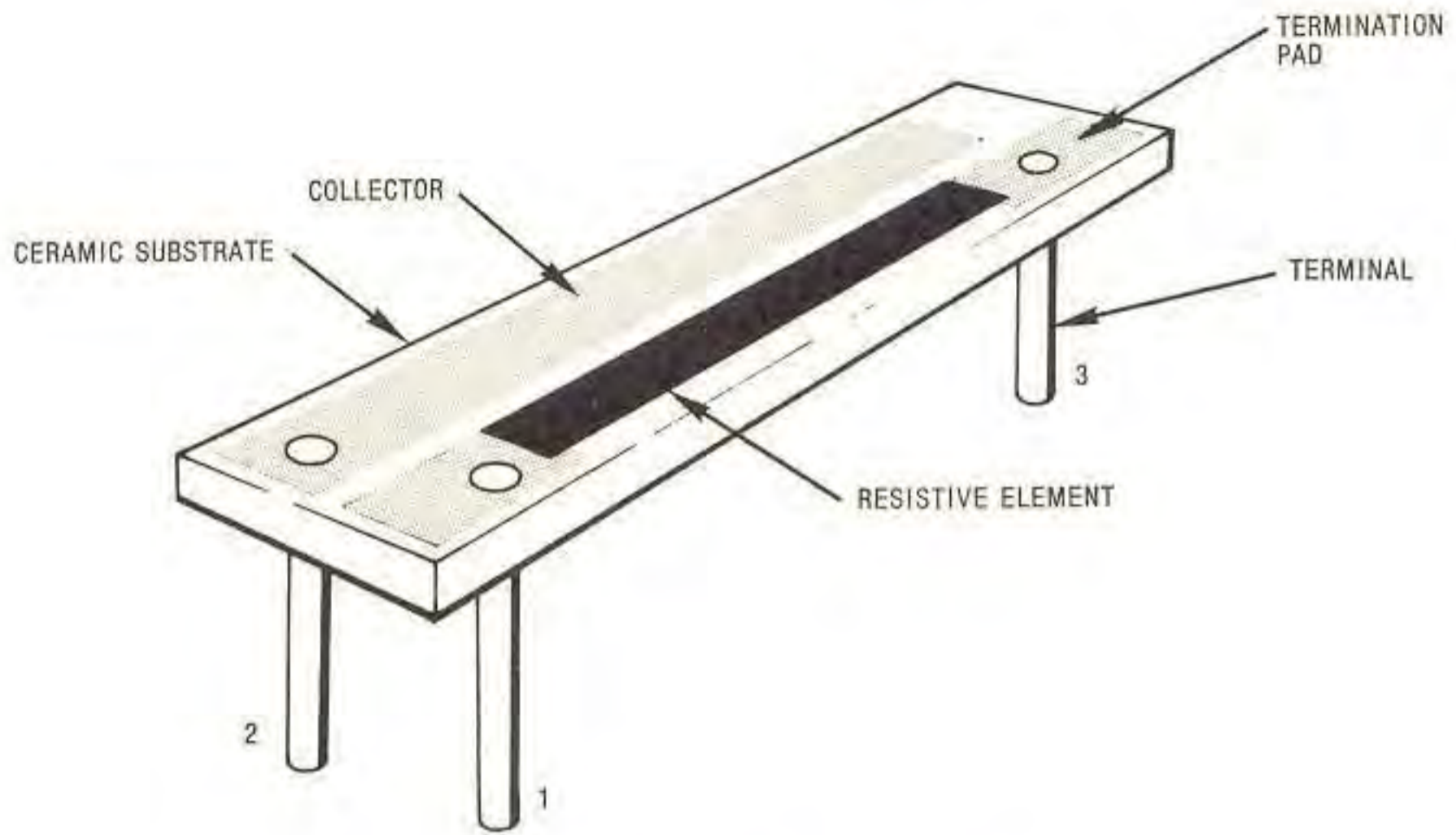

A. A COMMON CERMET POTENTIOMETER CONSTRUCTION

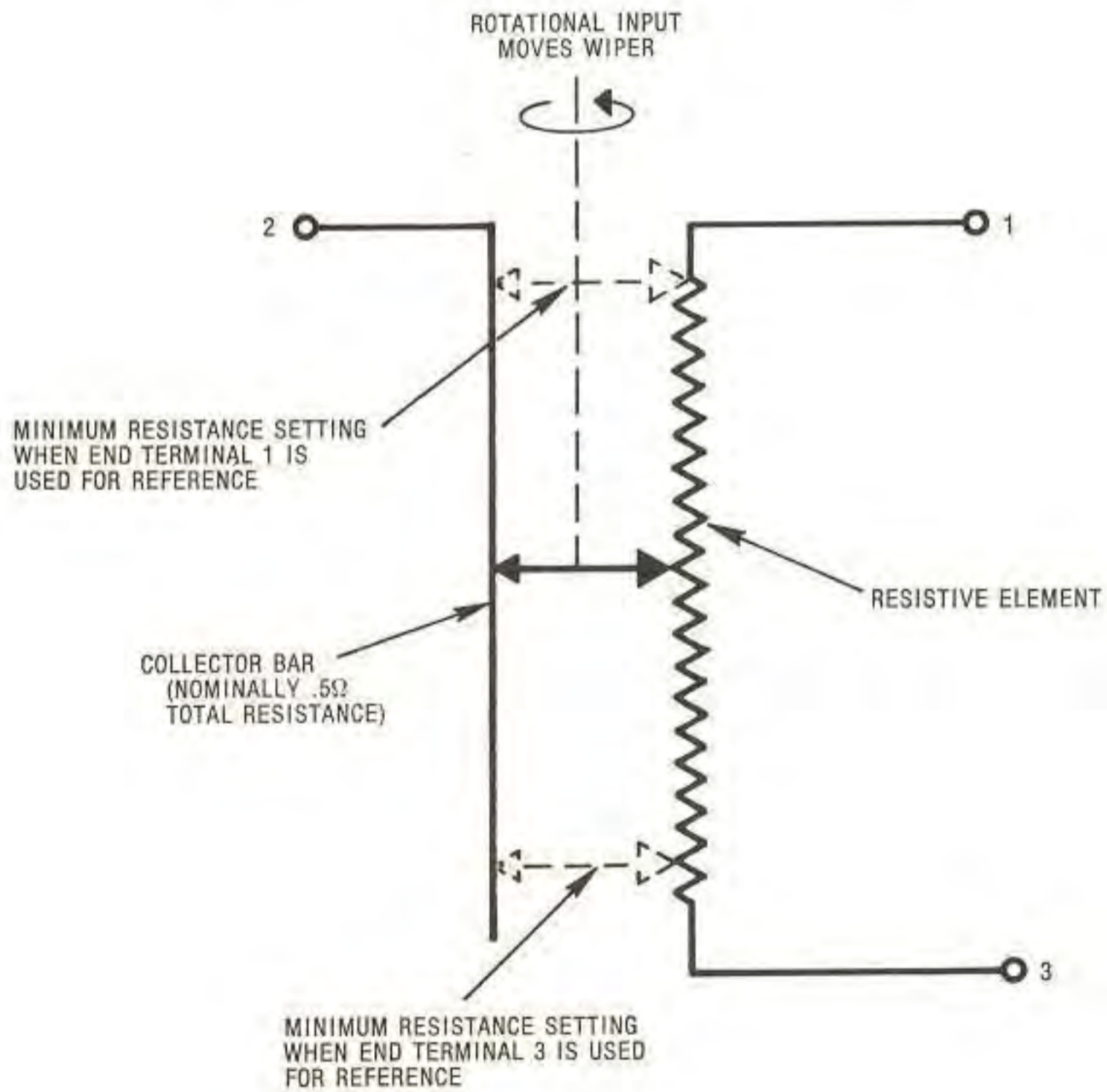

B. SCHEMATIC OF FIG. 2-7A

Fig. 2-7 Construction affects minimum and end-set parameters



# THE POTENTIOMETER HANDBOOK

IMPORTANT: ADJUST WIPER TO APPROXIMATE CENTER OF RESISTIVE ELEMENT BEFORE BEGINNING, THEN DO NOT CHANGE POSITION OF THE WIPER DURING THIS EXPERIMENT

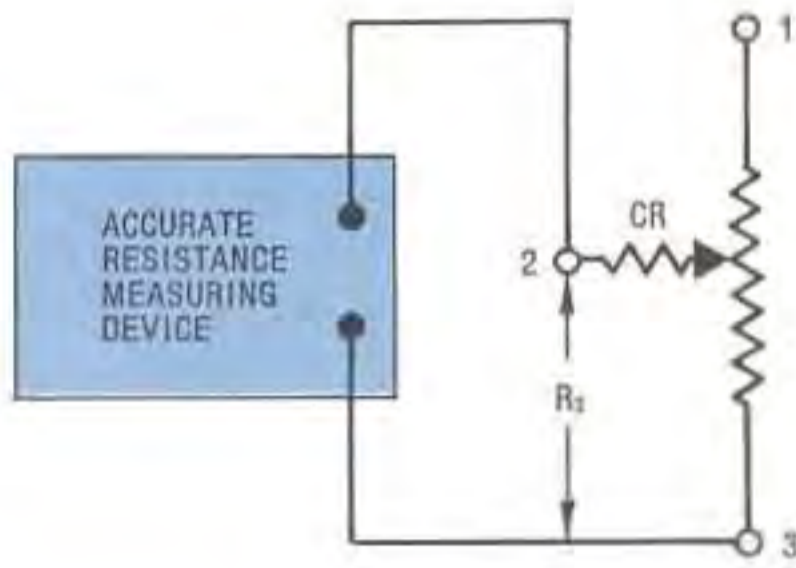

STEP 1: MEASURE AND RECORD  $R_1$

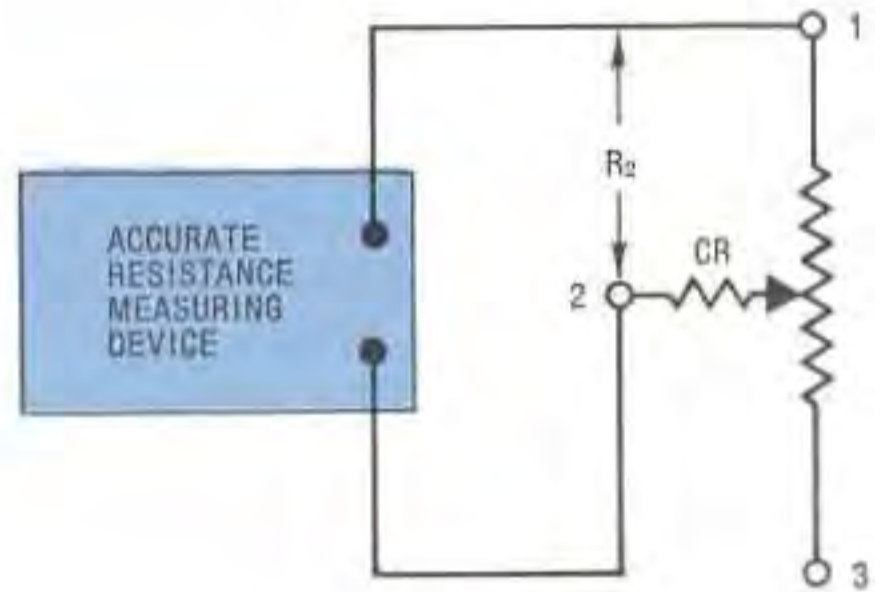

STEP 2: MEASURE AND RECORD  $R_2$

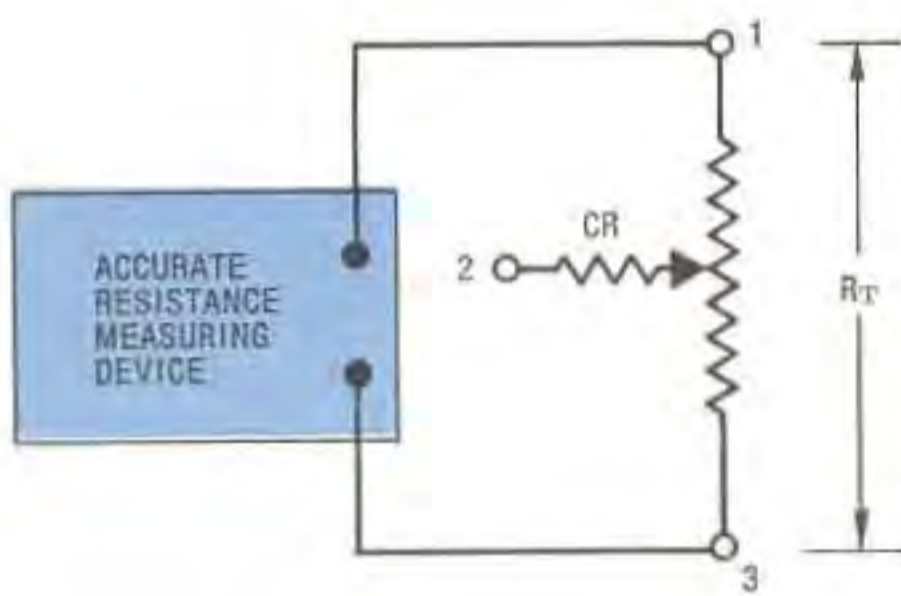

STEP 3: MEASURE THE POTENTIOMETERS  $R_T$  AND COMPARE WITH  $R_1 + R_2$

CONCLUSIONS:

$$R_T \neq R_1 + R_2$$

$$R_T < R_1 + R_2$$

$$\frac{[R_1 + R_2] - R_T}{2} = CR = \text{CONTACT RESISTANCE}$$

DIVISION BY 2 IS NECESSARY BECAUSE CR WAS MEASURED TWICE. ONCE IN STEP 1 AND AGAIN IN STEP 2.

**Fig. 2-8** Experiment to demonstrate contact resistance

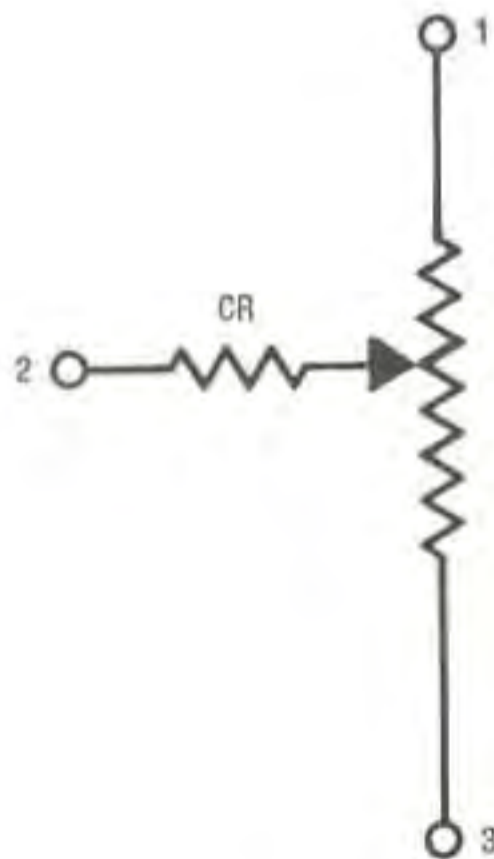

**Fig. 2-9** Potentiometer schematic illustrating contact resistance



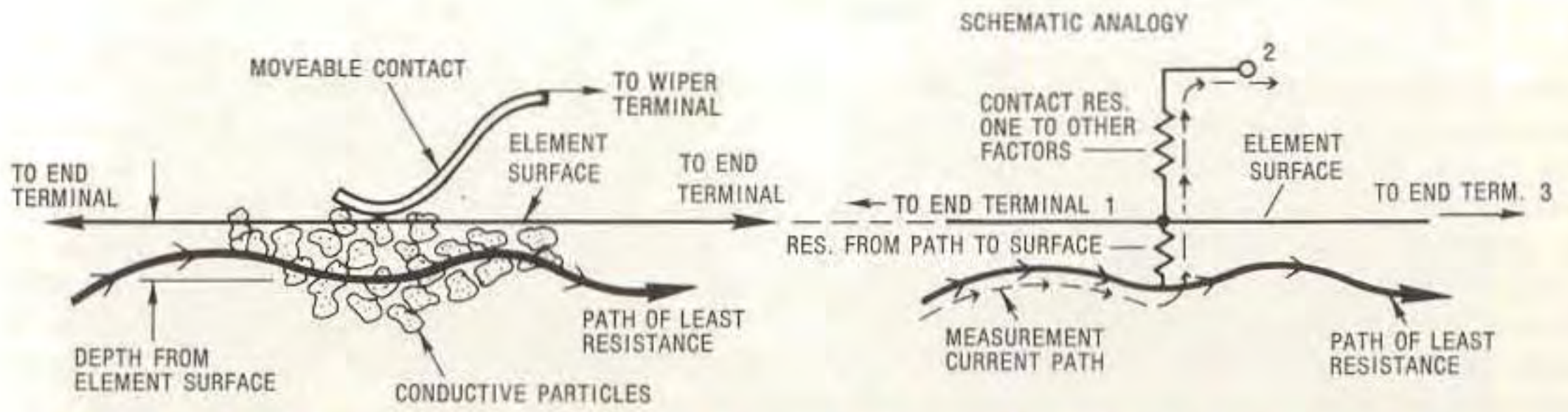

Fig. 2-10 Path of least resistance through element varies in depth from the element surface

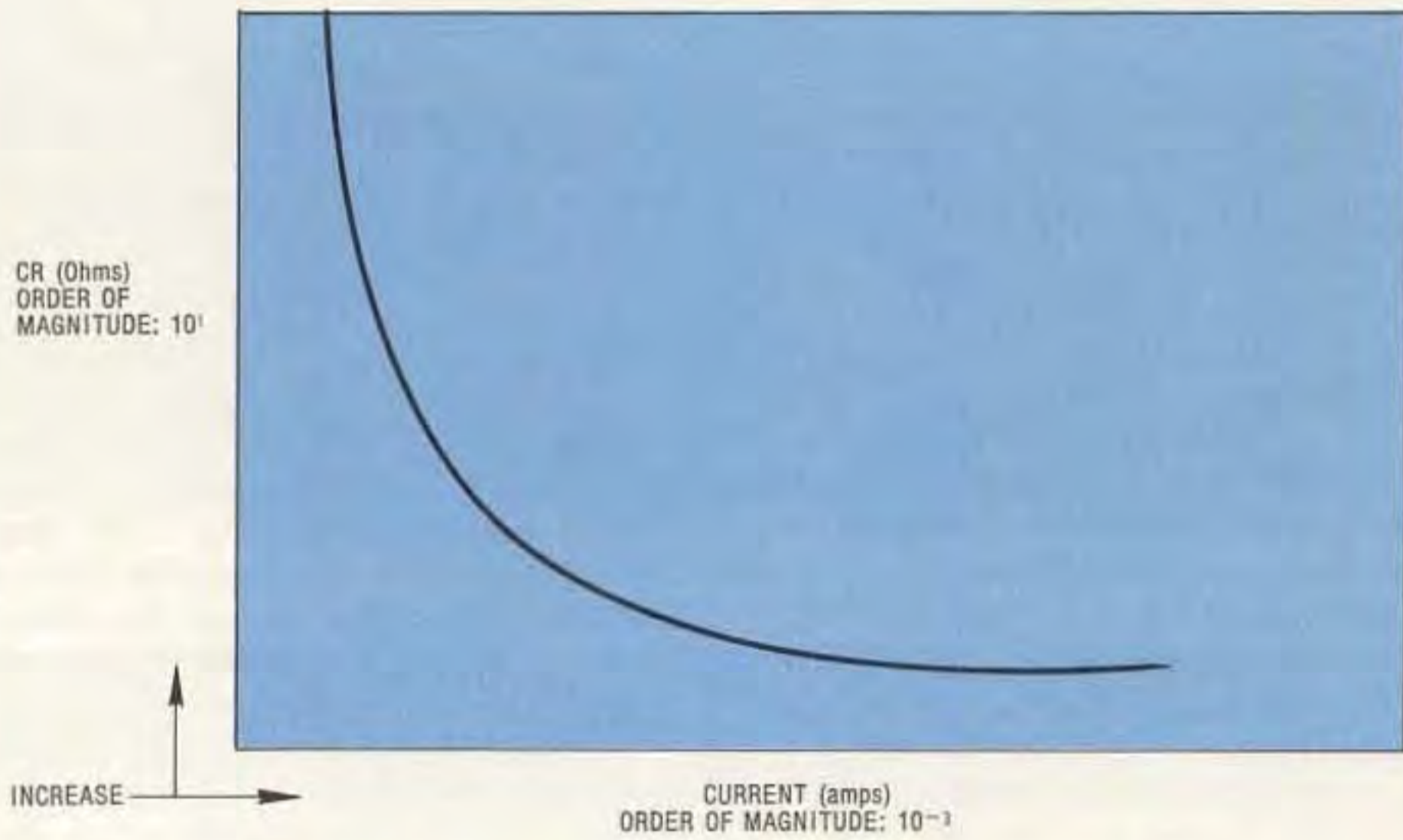

Fig. 2-11 Contact resistance varies with measurement current

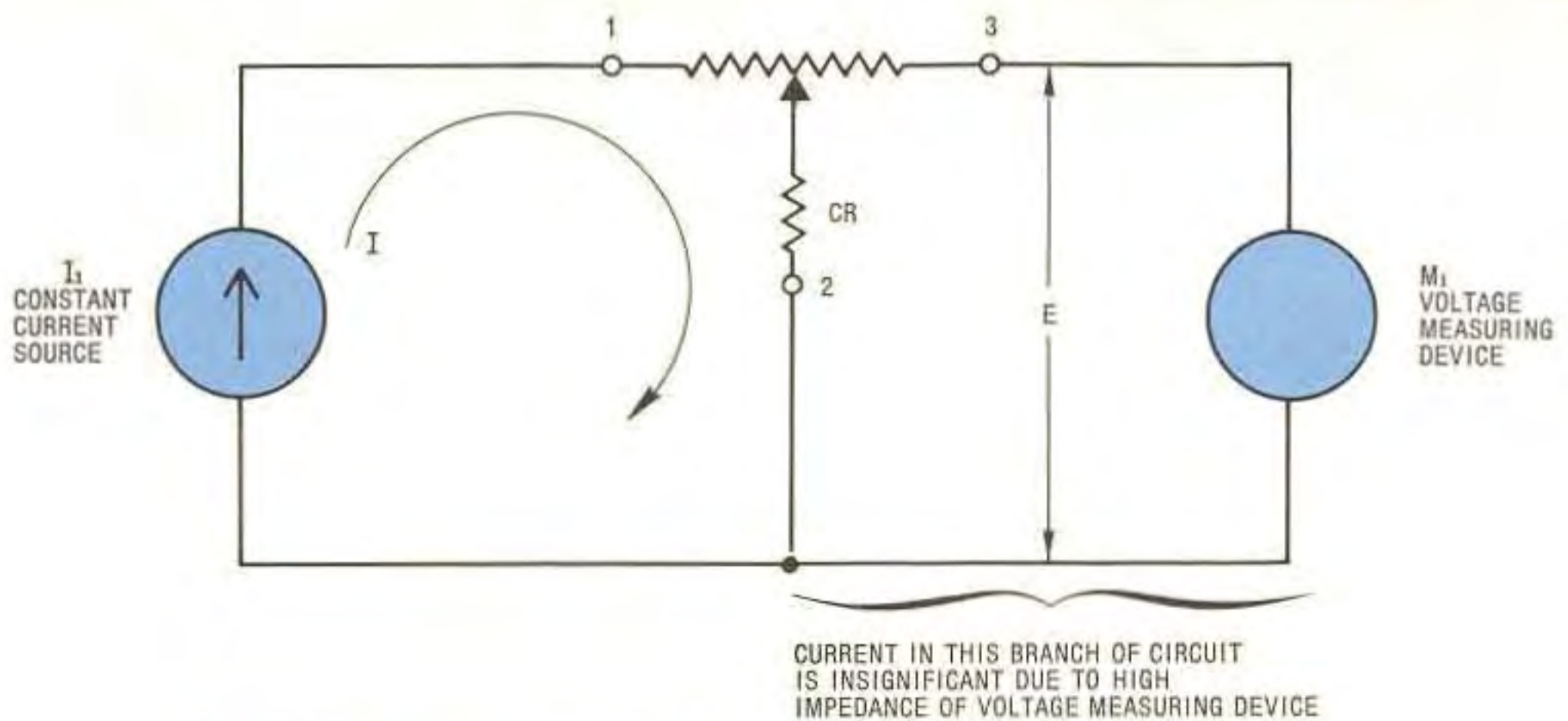

Fig. 2-12 Test configuration for measurement of contact resistance



$I_1$ , provides a test current,  $I$ , which is applied through the potentiometer. The current path is in one end terminal; through a portion of the element; through the contact resistance; and then out the wiper terminal 2. The open circuit voltage indicated on  $M_1$  will be proportional to the value of contact resistance.

It is not common procedure to specify or production inspect contact resistance. This is because for any given resistive element, there exists an infinite number of points along its surface where contact resistance could be measured. A very common specification, Contact Resistance Variation, is tested at the manufacturing stage and reflects the variable range of contact resistance as the wiper traverses the element.

### CONTACT RESISTANCE VARIATION, CRV

Contact Resistance Variation, CRV, is the maximum, instantaneous change in CR that will be encountered as the result of moving the wiper from one position to another. The limit of CRV is expressed as a percentage of the unit's total resistance or ohms. When the wiper is actuated, the resistance at the wiper terminal, with respect to either end terminal, is apt to increase or decrease by a value within the CRV specification. *1% of TR maximum and 3 ohms maximum* are typical CRV specifications.

A basic circuit for demonstrating CRV on an oscilloscope is shown in Fig. 2-13. A constant current source,  $I_1$  provides the current  $I$ . The path taken by  $I$  is indicated by a circular arrow. An oscilloscope with capacitor filter provides a detector that monitors the effective changes in

voltage drop across the contact resistance. The capacitor merely restricts the d.c. voltage component from the oscilloscope display. Only the variation in voltage due to CRV appears on the display.

The current sensitivity of CR, as previously mentioned, imposes restrictions on  $I$ . These restrictions are required for accuracy and meaningful data correlation. Fig. 2-14 is a table of typical current values for CRV measurement.

NOMINAL TOTAL RESISTANCE, TR (ohms)	CURRENT $I$ (mA)
< 50	30
50 TO < 500	10
500 TO < 100K	1
100K TO < 2 MEG.	0.1
$\geq$ 2 MEG.	0.05

Fig. 2-14 Current values for CRV measurement of cermet elements resistance variation

Industry standard test conditions require the use of a 100 Hz - 50 kHz bandpass filter in lieu of the capacitor of Fig. 2-13. This filter accomplishes the restriction purpose of the capacitor and, in addition, limits the CRV response to those values within the bandpass spectrum. This limitation is justified because the frequency response of most systems utilizing potentiometers is within the filter bandpass.

The oscilloscope photograph of Fig. 2-15 illustrates a CRV display using the circuit of Fig. 2-13 with a mechanical device to uniformly cycle the wiper. This equipment is pictured in Fig. 2-16. The oscilloscope photograph shows

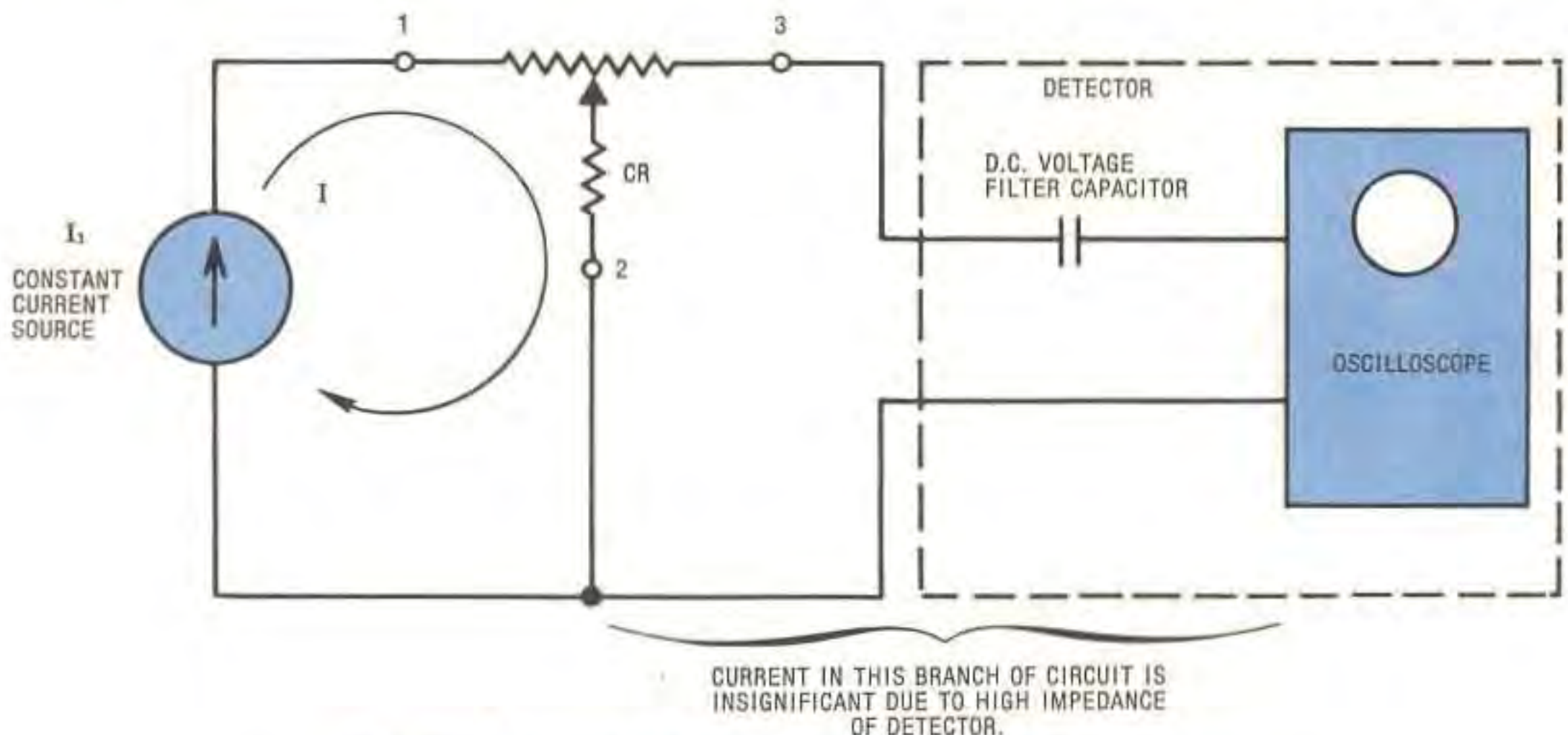
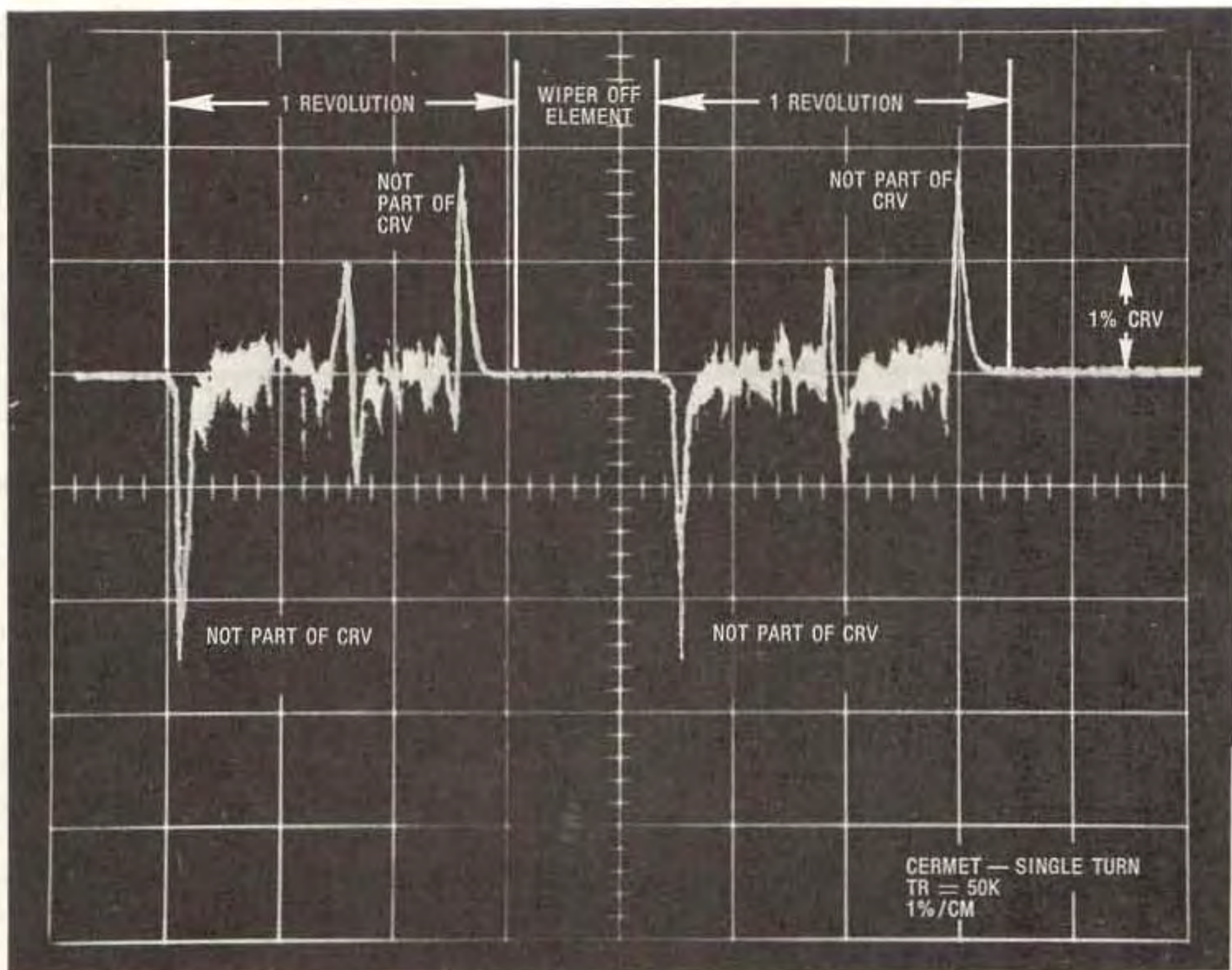
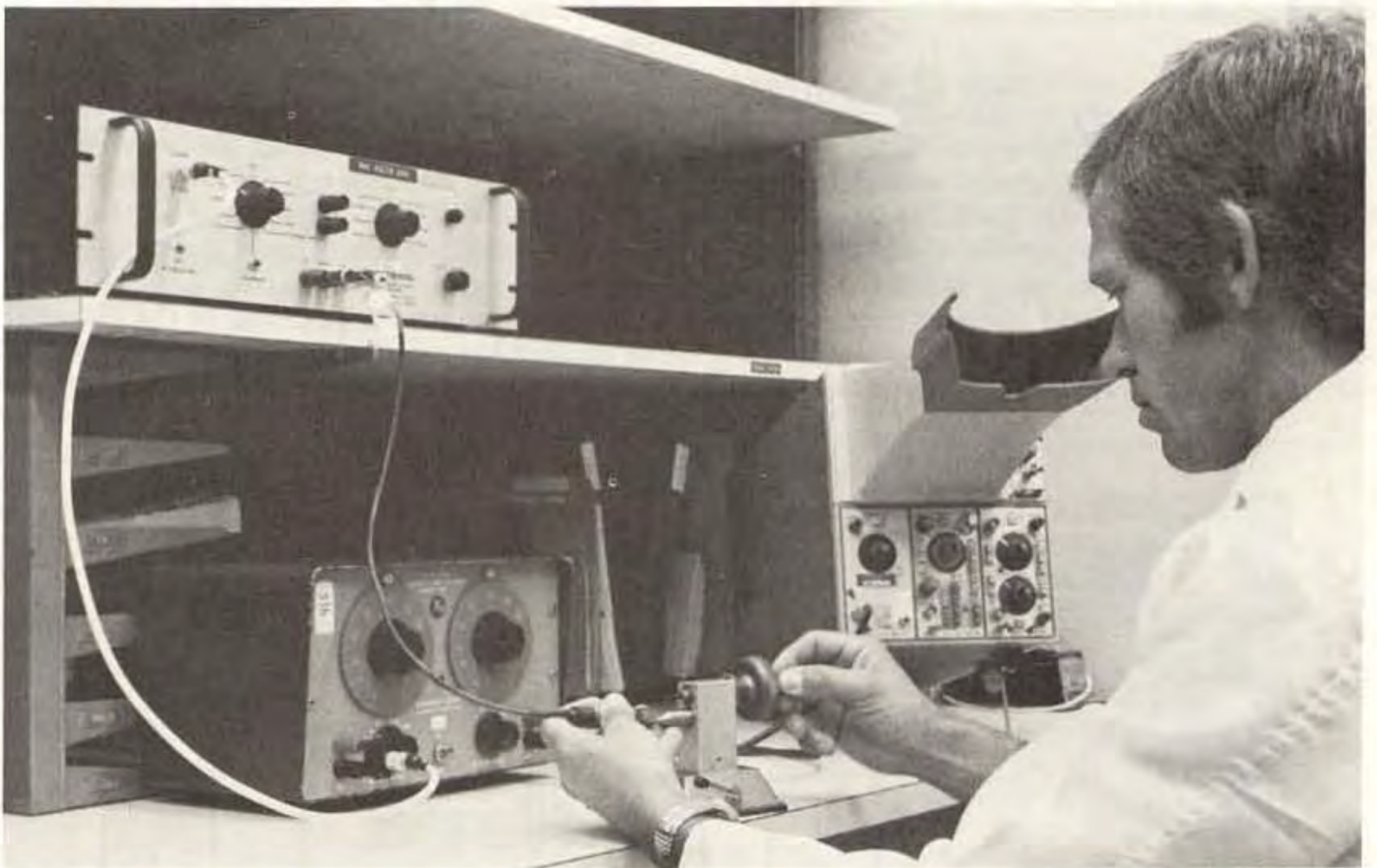

Fig. 2-13 Circuit for demonstration of contact variation





**Fig. 2-15** Oscilloscope Display of CRV



**Fig. 2-16** Equipment configuration for CRV demonstration



two complete revolutions of a single turn potentiometer. The extreme variations at the beginning and end of the oscilloscope trace are due to the wiper movement off or onto the termination areas. They are not considered contact resistance variation.

### EQUIVALENT NOISE RESISTANCE, ENR

Potentiometers with wirewound elements use the parameter of Equivalent Noise Resistance, ENR, to specify variations in CR.

Before defining ENR, it is necessary to introduce some new terminology. Fig. 2-17 depicts the potentiometer in a voltage-divider mode. Refer to Chapter 3. In this configuration, it is common to refer to the electrical signal present at the unit's end terminals, 1 and 3, as the *input* and the signal present at the wiper terminal 2 as its *output*. If the voltage division performed by the potentiometer was ideal, a graph of the output function as the contact moved from end terminal 3 to end terminal 1 would be a straight line from zero to  $E_T$ . It would have a slope equal to the ratio of total input voltage to total resistance. However, when the output is precisely monitored with an oscilloscope, it is observed that the potentiometer not only deviates from the ideal concept, but some degree of electrical noise or distortion is also present on the output waveform. This distortion is imposed by the device itself.

Many factors contribute to ENR, including all of those previously mentioned as contributing to CR and CRV. Oxide film buildup on the surface of the resistive element will act as an insulator until rubbed away by the friction of the wiper. Minute foreign particles resulting from a harsh operating environment may find their way between the wiper and element creating the same effect. Even microscopic bits of metal resulting from friction wear of the parts can lodge

between the resistive element turns affecting ENR.

When these foreign substances interfere with wiper contact they give wirewound potentiometers a dynamic output characteristic which is sporadic and nonrepeatable.

Potentiometer manufacturers specify ENR, a theoretical (lumped parameter) resistance, in series with output terminal 2. This resistance will produce the equivalent loss in an ideal potentiometer. The most common specification of Equivalent Noise Resistance is *100 ohms maximum*.

The earlier discussion on CRV applied only to potentiometers having non-wirewound (film type) resistive elements. These elements present a continuous, smooth path for the wiper. With wirewound elements, the path provided is relatively less smooth and continuous. The wiper effectively *jumps* and *bridges* from one turn of resistance wire to the next. The simplified drawing of Fig. 2-18 emphasizes this bridging action. The wiper usually does not make connection with only one turn of wire but actually touches several at once. This depends on the relative width of the contact to the wire size and spacing.

In Fig. 2-18 the wiper is assumed, solely for illustrative purposes, to be wide enough to touch only two turns when in position A or touch only one turn when at position B. When two turns are simultaneously contacted, that portion of the resistive element bridged by the wiper, is bypassed (i.e., shorted electrically). As a result, the resistance of the *shorted* turn will decrease and change the devices output voltage.

Some aspects of ENR are circuit application dependent, such as the load current  $I_2$ , in Fig. 2-17. Most causes are traceable to the variation of contact resistance as the wiper moves across the element. For simple physical demonstration,

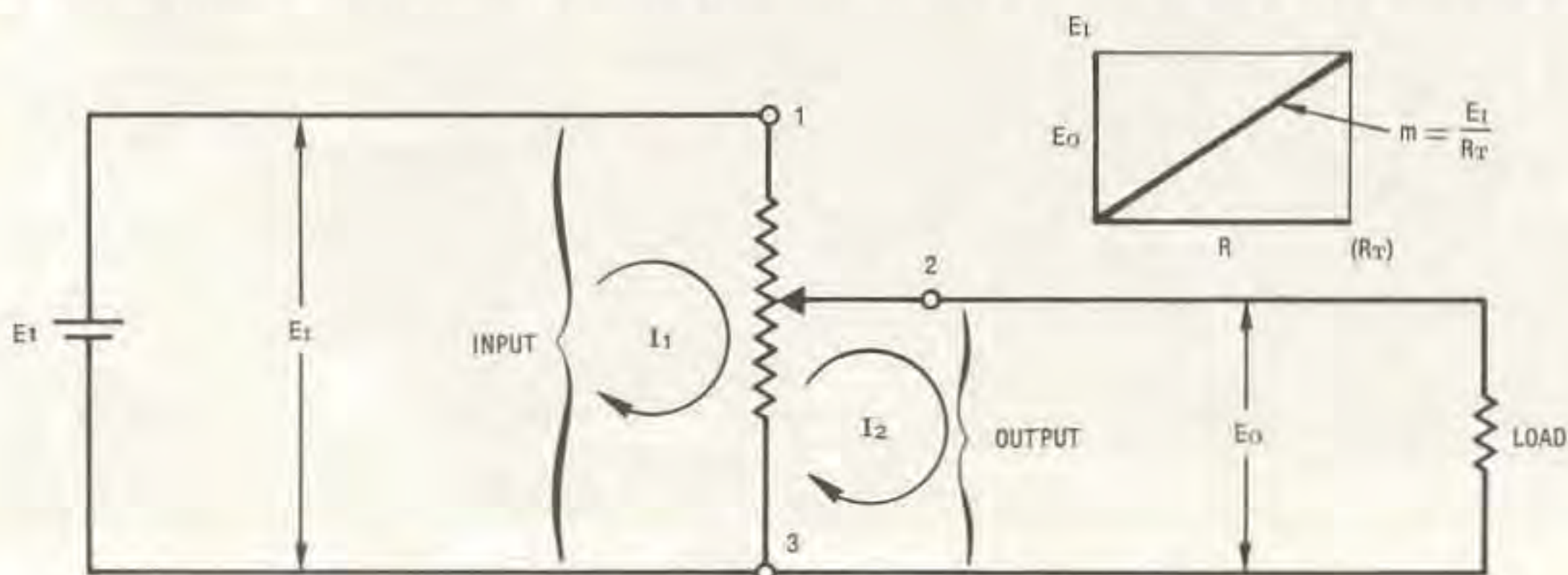
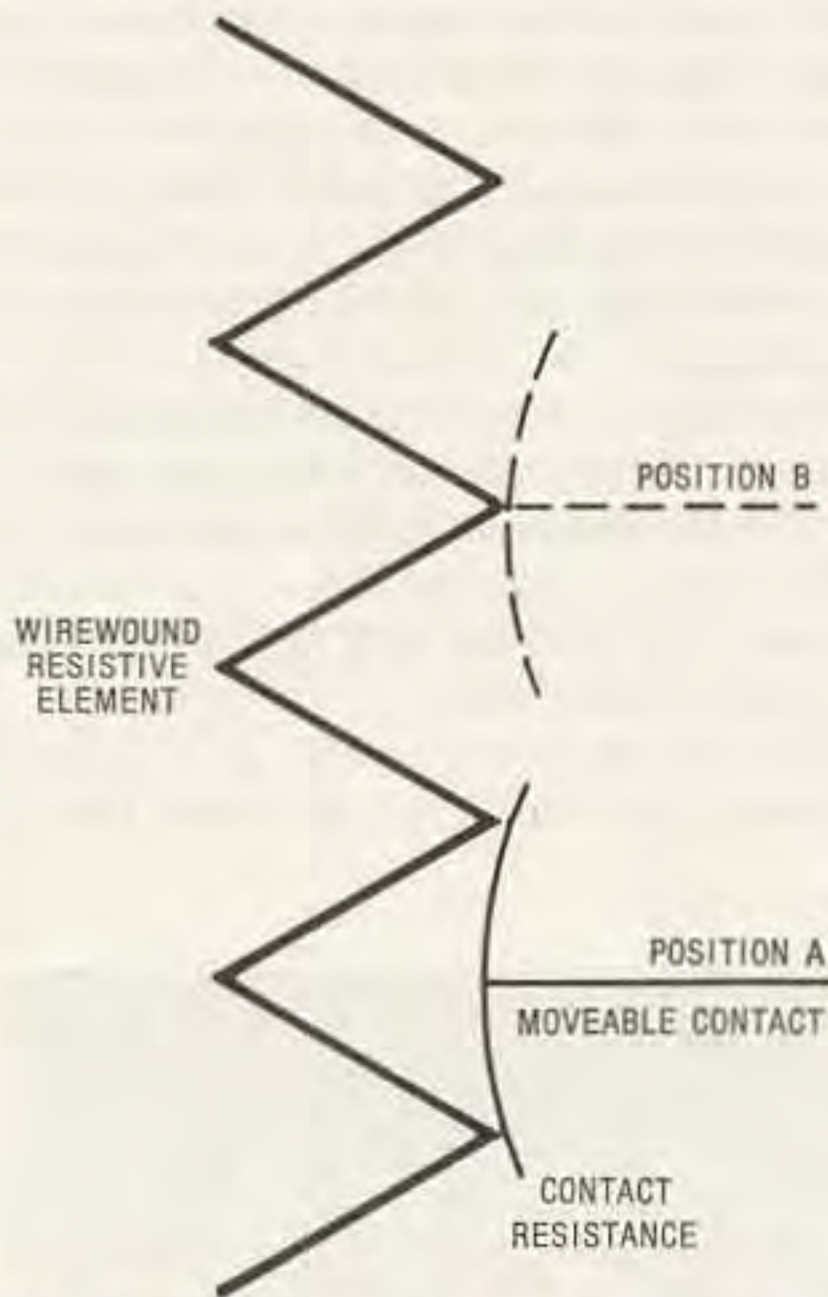

Fig. 2-17 Load current is a contributor to ENR



the circuit in Fig. 2-13 can be used as shown by Fig. 2-19. A one milliamp constant current is passed through the wiper circuit. The resulting voltage drop from wiper to element is monitored by a detector circuit while the wiper is cycled back and forth across the element. The detector circuit consists of an oscilloscope and voltage regulating diode, D. The diode protects the potentiometer from excessive voltage by providing a conductive path for the 1ma current if the wiper circuit becomes open. The display presented on the oscilloscope screen could be



**Fig. 2-18** A varying number of resistance wire turns make contact with the wiper

like one of those shown in Fig. 2-20. The waveforms were measured on two different potentiometers. Unit number 1 shows more noise than unit number 2. The calibration of the oscilloscope is only  $5\Omega/\text{cm}$ . Note that the greatest deviation of unit number 1 is about  $4\Omega$  while unit number two remains well below  $0.5\Omega$  for its entire travel.

If the oscilloscope were not calibrated in  $\Omega/\text{cm}$ , the ENR for a particular unit could be determined by first measuring the *maximum* peak voltage drop,  $E_p$ , with the test current fixed at one milliamp. The Equivalent Noise Resistance could then be calculated by:

$$\text{ENR} = \frac{E_p}{I} = \frac{E_p}{.001} = E_p \cdot 10^3$$

ENR will be given in ohms if the value of  $E_p$  is in volts. The ENR of a particular unit may be so low that accurate determination of the exact value is difficult, e.g. unit number 2 in Fig. 2-20. However, ENR is specified as a maximum and it is a simple task to determine that any particular unit remains below its specified maximum.

The industry standard test circuit for ENR uses a low pass filter in place of the capacitor in Fig. 2-19. While this filter limits the amount of noise seen by the oscilloscope, its bandwidth (1 kHz) is in excess of the bandwidth of most systems in which the potentiometer will be utilized. This means it does not filter out any significant distortion.

### ENR AND CRV

The analogy of ENR and CRV should be quite obvious. Both specifications are dynamic parameters and are highly dependent upon the fundamental electronic concept of contact resistance. Equivalent Noise Resistance, for wire-

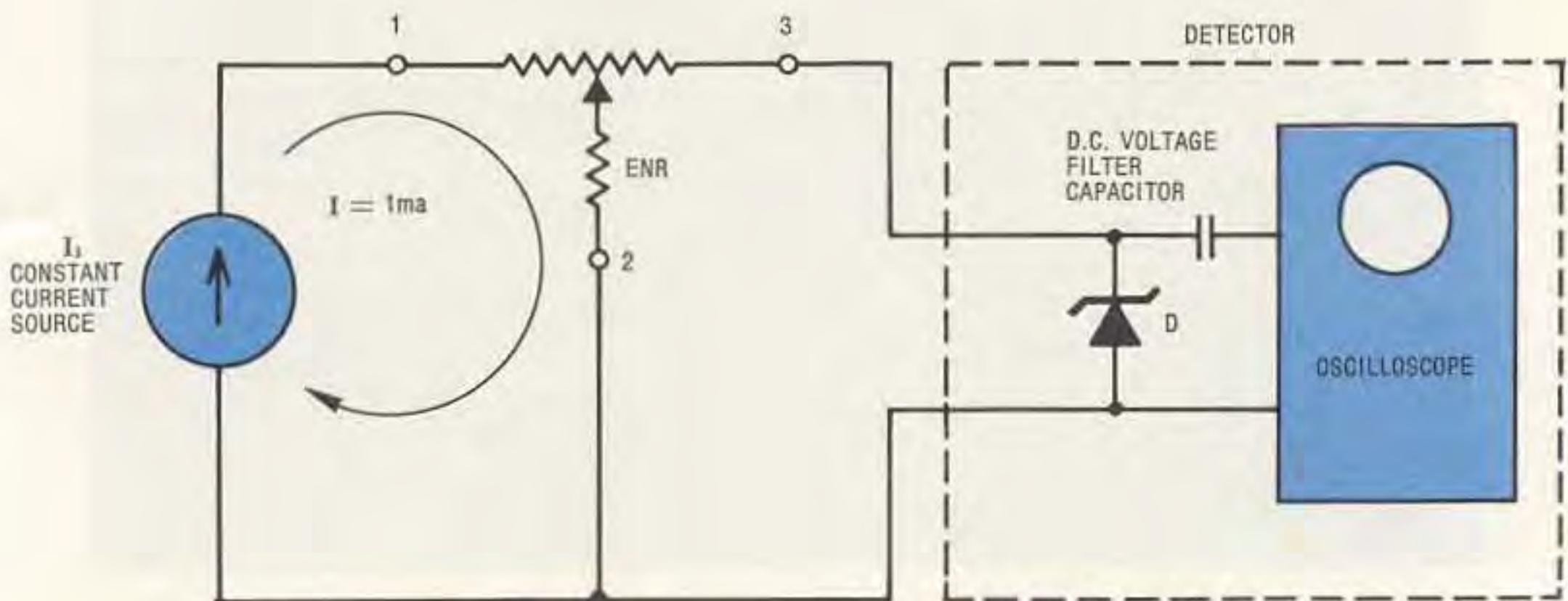

**Fig. 2-19** Demonstration of ENR



wound potentiometers, was adopted by manufacturers and users, as a quality indicator a number of years in advance of Contact Resistance Variation.

To better understand today's need for both ENR (wirewound) and CRV (nonwirewound) specifications, some details of element construction must be understood. (For full details, see Chapter 7.)

A major portion of total resistance ranges attainable with wirewounds are made with the same resistance wire alloy. To manufacture a variety of resistance values, the resistance wire size is simply changed and more or less wire is wound on the element. This means the metal-to-metal interface between element and wiper is identical for most resistances.

Total resistance of nonwirewound (carbon and cermet) elements cannot be changed this simply. Instead, slightly different compositions and/or processes are used to change resistance. This means the element to wiper interface (contact resistance) varies with total resistance. This contact resistance is by nature less conductive than the wirewound counterpart.

The result is a more dynamic contact resistance parameter for nonwirewound. From a practical standpoint, although the circuit used

resembles the one for ENR, a different calibration is needed to adequately observe CRV.

Since nonwirewound potentiometers are ideal for many applications, the CRV specification is commonly specified. Wirewounds continue to use the ENR specification.

## OUTPUT SMOOTHNESS, OS

Output smoothness, OS, applies to potentiometers with non-wirewound elements used for precision applications. This parameter is the maximum instantaneous variation in output voltage, from the ideal output voltage. It is measured while the wiper is in motion and an output load current is present. Output smoothness is always expressed as a percentage of the total input voltage. A typical specification is *0.1% maximum*.

The factors contributing to contact resistance and contact resistance variation are all causes of output voltage variations. Because these parameters are current sensitive, the presence of an output load current is a significant contributor to output smoothness.

The circuit shown in Fig. 2-21 is the industry standard test circuit but is shown here for dem-

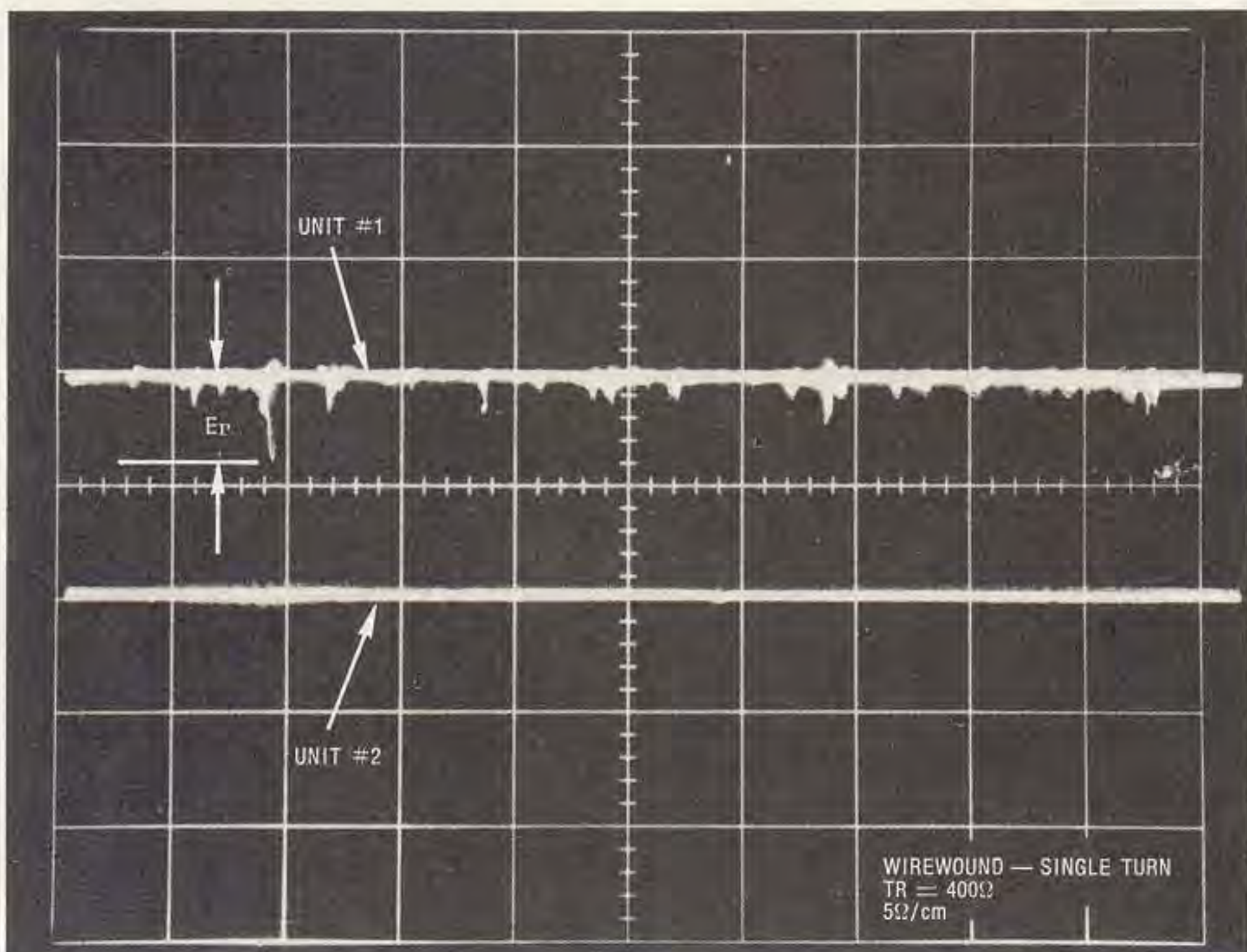

Fig. 2-20 Oscilloscope traces of ENR for two different potentiometers



onstration only. A stable, low noise voltage source  $E_1$ , is connected as an input to the potentiometer. The output of the device is applied to a load resistor,  $R_1$ , and to the input of a smoothness filter. The output of the filter is then monitored with an oscilloscope or strip-chart recorder. The ohmic value chosen for  $R_1$  is not arbitrary but should be two orders of magnitude ( $10^2$ ) greater than the potentiometer's total resistance.

The bandpass filter of Fig. 2-21 accomplishes the same major task as the filters used for CRV and ENR demonstrations. These filters remove the d.c. component and restrict noise transients to frequencies encountered in applications. The choice of a filter is not critical for purposes of demonstrating CRV, ENR or OS. Remember, when interpreting manufacturer's data sheets, that these specifications are based on industry standard test conditions which include the use of a *specific* filter.

All electronic specifications, to be meaningful, assume a set of test conditions. Output

smoothness is no exception. When the circuit of Fig. 2-21 is used as an academic aid, the industry standard test conditions can be simulated by using a mechanical fixture to actuate the moveable contact. The fixture should be capable of driving the potentiometer adjustment mechanism at a rate of 4 revolutions per minute. The resulting strip-chart trace could look something like Fig. 2-22. To determine the device's output smoothness, select the greatest recorded change in output voltage (within a 1% travel increment) and express it as a percentage of the total input voltage, or:

$$OS = \frac{e_{\max}}{E_1} \times 100$$

### ADJUSTABILITY, A

Although many manufacturer's data sheets specify adjustability, A, this characteristic is the newest potentiometer parameter. It is the result of industry's efforts to further clarify the impor-

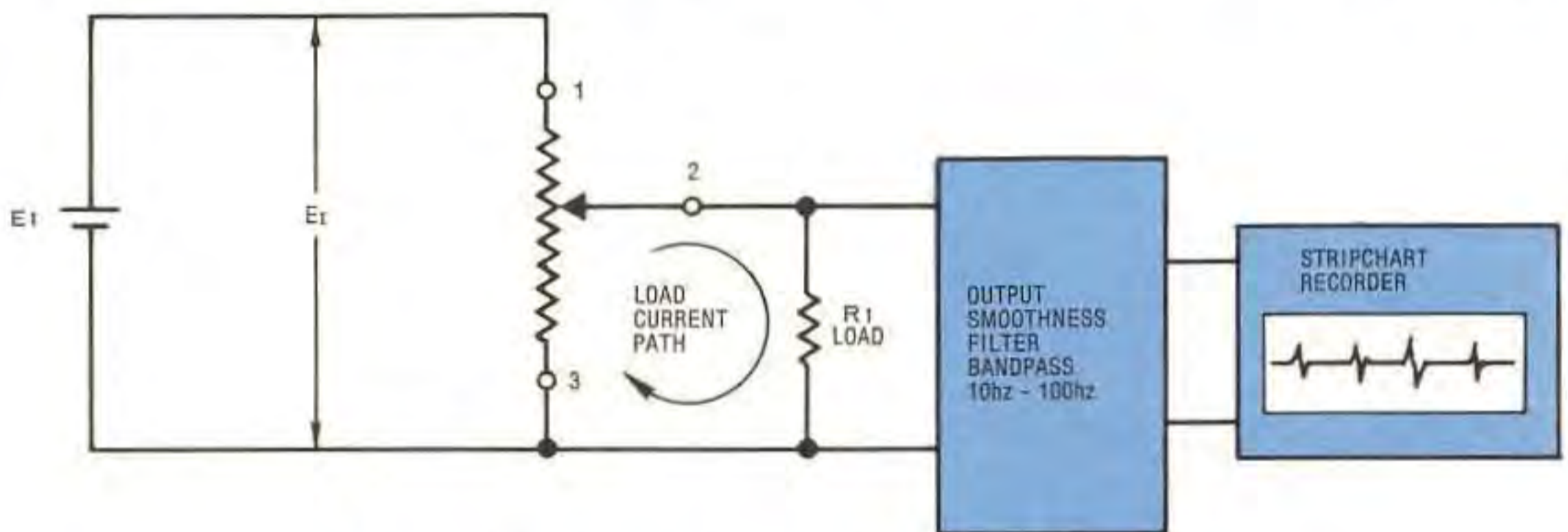
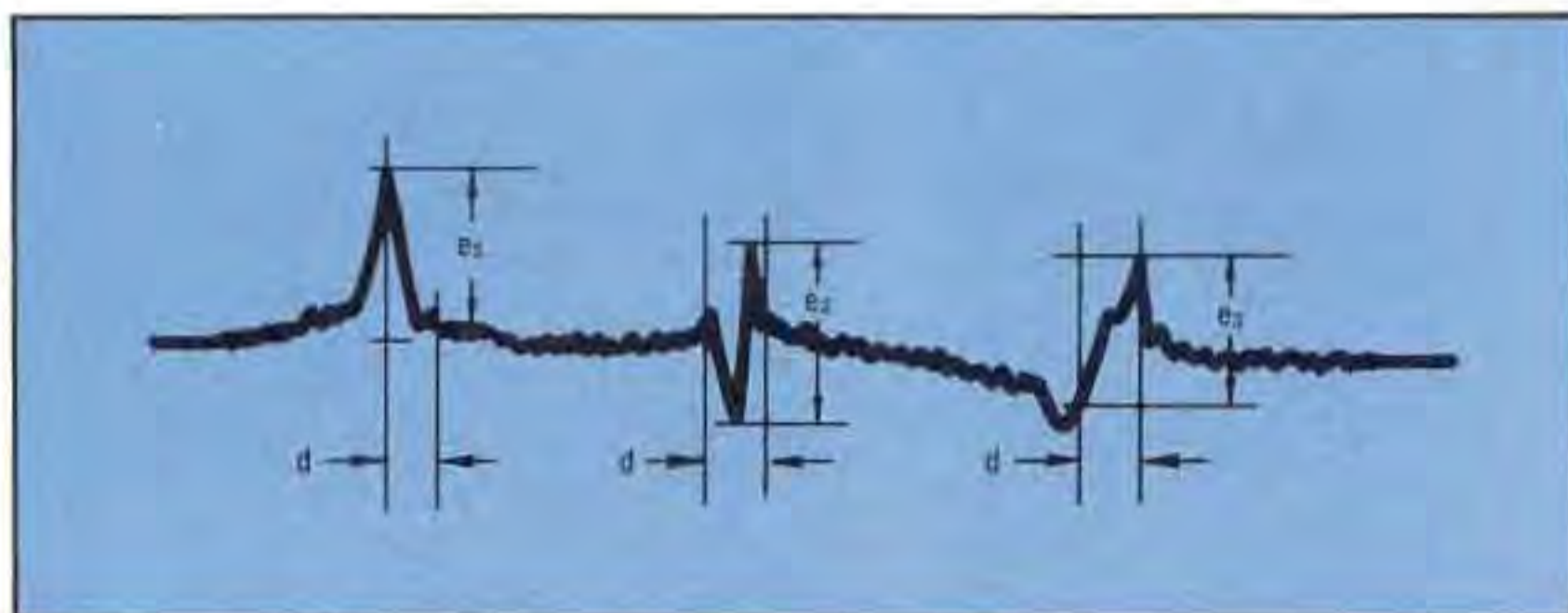

Fig. 2-21 Configuration for output smoothness demonstration



$d = 1\%$  OF TOTAL ELECTRICAL TRAVEL  
 $e =$  PEAK TO PEAK VARIATION WITHIN THE HORIZONTAL MOVEMENT INCREMENT,  $d$

Fig. 2-22 Evaluation of the output smoothness recording



tant effect of wiper-element interaction related to circuit applications.

The specification is new but anyone who has tuned an electronic circuit, has tested a potentiometer's adjustability. This includes common household appliances and complex electronic systems. In some circuits only coarse adjustment is required to produce desired response. In this case, the adjustability of the potentiometer is not critical. In other applications, time consuming fine adjustment is required to achieve desired circuit function. Here, the adjustability is very critical.

Adjustability, as inferred by the previous paragraph, is the accuracy and ease with which the wiper can be positioned to any arbitrarily selected point along the resistive element.

Because the potentiometer is most often applied in one of two modes, (Chapter 3) adjustability parameters are specified for each: Adjustability of in-circuit resistance, (variable current rheostat mode), Adjustability of output

voltage ratio, (voltage divider mode). Adjustability of in-circuit resistance is sometimes referred to as adjustability of output resistance.

Fig. 2-23 illustrates the simplest method of demonstrating adjustability of in-circuit resistance. After setting the wiper as close as possible to 50% of the device's TR, the adjustability of resistance as a percent of TR can be calculated from:

$$A_R \% = \frac{(\text{Achieved reading} - (0.5 \text{ TR}))}{\text{TR}} \times 100$$

Fig. 2-24 shows a circuit for measurement of adjustability of output voltage ratio. After attempting to adjust the wiper to achieve a reading of .50 on the DVM, the adjustability of the output voltage ratio as a percent of the attempted setting, is easily calculated from:

$$A_V \% = \left\{ (\text{achieved ratio}) - (.50) \right\} \times 100$$

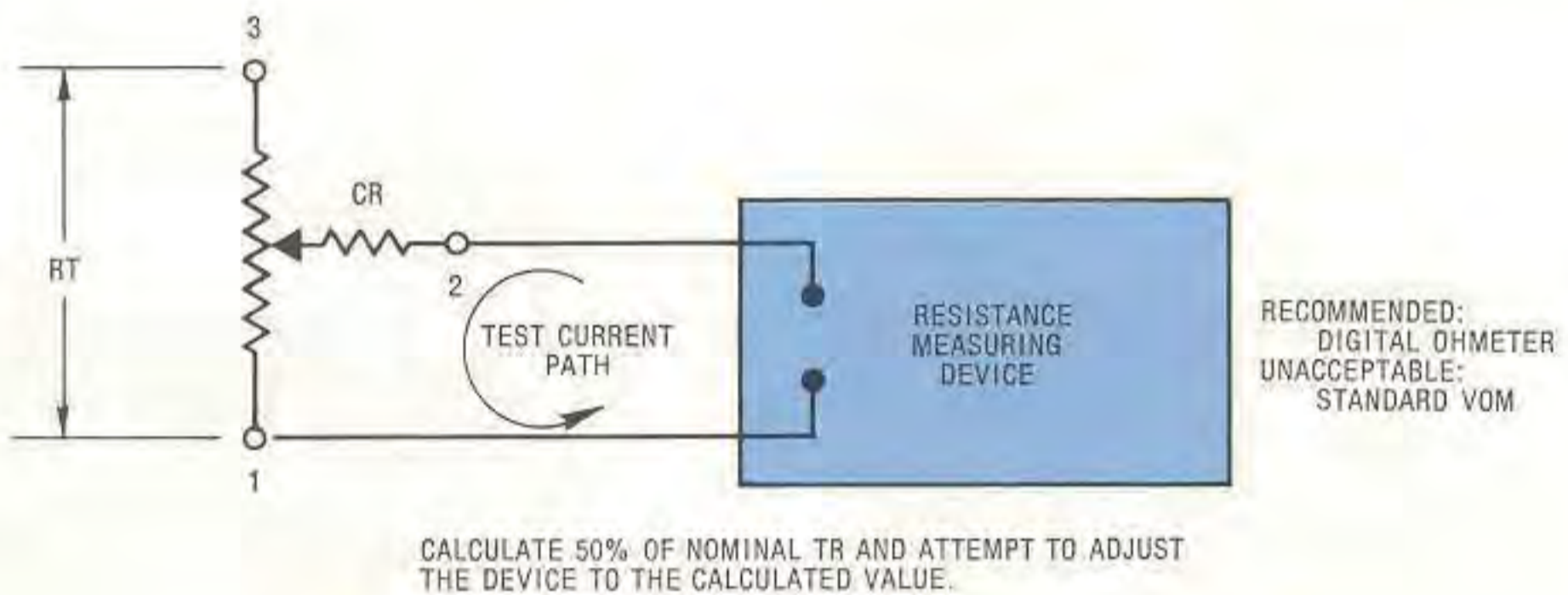

Fig. 2-23 Adjustability of in-circuit resistance

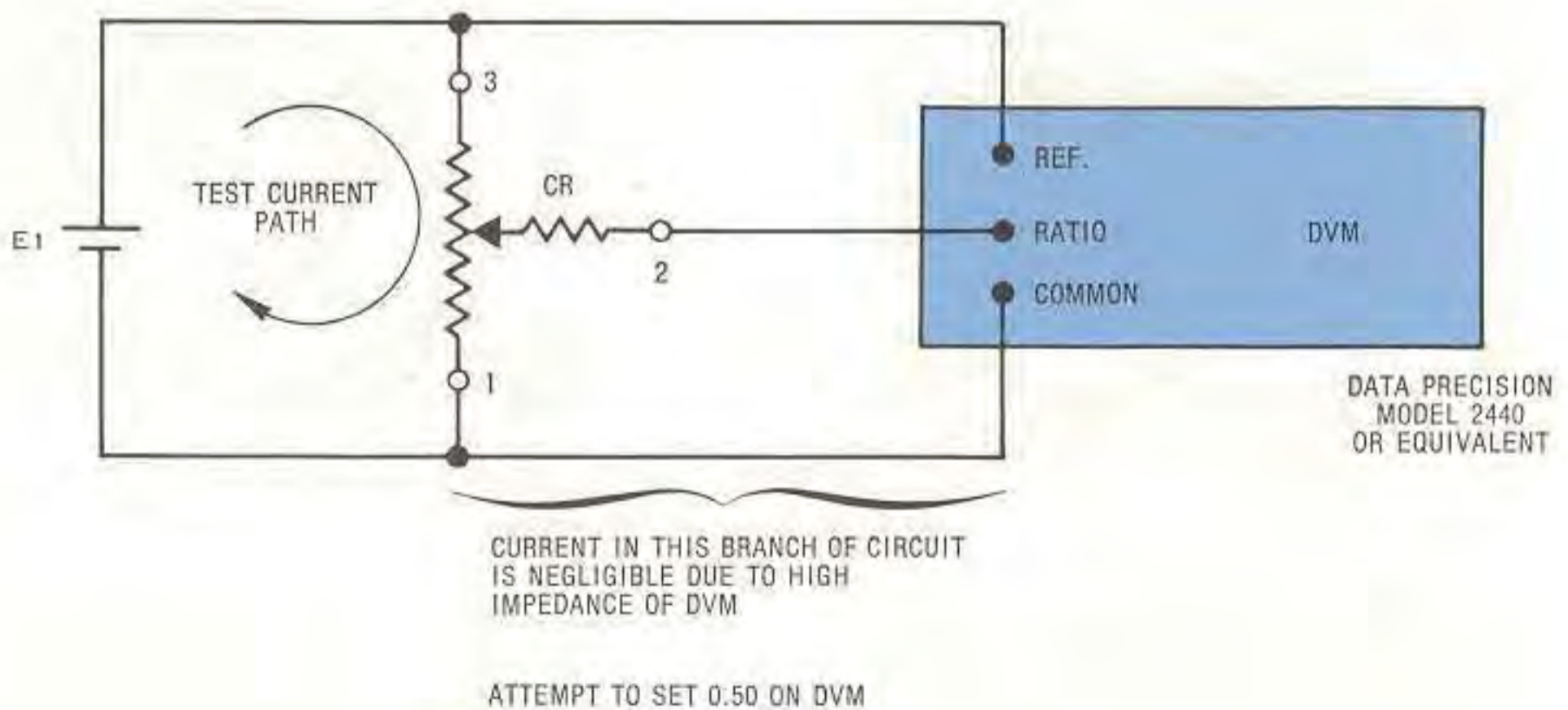

Fig. 2-24 Adjustability of voltage division



Since voltage drop and resistance are directly proportional,  $A_R$  and  $A_V$  might be erroneously considered equivalent. A comparison of Figures 2-23 and 2-24 will show that the test current path is through the wiper, and hence through the contact resistance, for measurement of  $A_R$ . The test current is excluded from the wiper circuit for  $A_V$  measurement. This fact causes  $A_R$  specifications to be higher than  $A_V$  specifications. A typical value for  $A_R$  is  $\pm 0.1\%$ . While  $A_V$  for the same device could be as low as  $\pm 0.05\%$ .

The choice of a 50% setting point in the previous examples for adjustability is arbitrary. For consistency and meaningful data correlation, in-

dustry standard test procedures specify 30%, 50% and 75% as test settings. These settings must be made within a 20 second time limit.

### TEMPERATURE COEFFICIENT OF RESISTANCE, TC

The temperature coefficient of resistance, TC, is an indication of the maximum change in total resistance that may occur due to a change in ambient operating temperature. This parameter is usually specified in parts per million per degree Celsius (Centigrade) or PPM/ $^{\circ}\text{C}$ . Temperature coefficient is, to a great extent, dependent upon the type of material used to construct the resistive element and the physical structure



**Fig. 2-25** Equipment configuration for temperature coefficient demonstration



of the unit. For example, potentiometers utilizing cermet elements typically have a temperature coefficient of  $\pm 100 \text{ PPM}/^\circ\text{C}$ . Wirewound element devices typically have  $\pm 50 \text{ PPM}/^\circ\text{C}$  maximum. It is important to note that total resistance can vary directly or inversely with temperature.

Proper demonstration of a potentiometer's TC requires the use of a temperature chamber and a means for monitoring the chamber's temperature. Also needed is a resistance measuring instrument wired to the potentiometer so that total resistance can be accurately measured in the closed chamber. Fig. 2-25 shows this equipment. To determine the TC for a particular unit, measure and record the devices TR for two ambient temperatures. The two temperatures should be separated by at least  $25^\circ\text{C}$ . Allow sufficient time for temperature stabilization at each temperature.

Then:

$$\text{TC} = \frac{\text{TR}_2 - \text{TR}_1}{\text{TR}_1(T_2 - T_1)} \times 10^6$$

TC = Temperature coefficient in PPM/ $^\circ\text{C}$

$\text{TR}_1$  = TR at ambient temperature  $T_1$

$\text{TR}_2$  = TR at ambient temperature  $T_2$

$10^6$  is conversion factor to PPM

The resistance must be expressed in ohms and temperatures in  $^\circ\text{C}$ .

Industry standard test conditions require TR readings to be taken at several temperatures (as many as seven). Using the above formula, the resistance shift for each ambient temperature is evaluated to determine conformance to the TC specification.

Occasionally, in existing literature, the sub-

ject of temperature coefficient will include reference to *resistance temperature characteristic*, RTC. This parameter is nothing more than the total resistance change that may occur over a specified ambient temperature range. It is expressed as a percentage of the TR value at a given reference temperature. Mathematically:

$$\text{RTC}\% = \frac{\text{TR}_2 - \text{TR}_1}{\text{TR}_1} \times 100$$

RTC = Resistance temperature characteristic from  $T_1$  to  $T_2$

$\text{TR}_1$  = TR at ambient Temperature,  $T_1$   
(Reference Temperature)

$\text{TR}_2$  = TR at ambient temperature,  $T_2$

The resistances must be expressed in ohms.

Comparison of the formulas for TC and RTC will show that RTC is simply a percentage change (parts per hundred) in total resistance. For the same measurement conditions, TC is RTC expressed in parts per million – per degree Celsius.

## RESOLUTION

There are three types of resolution. Each is a measure of the incremental changes in output with wiper travel characteristic of wirewound potentiometers. For non-wirewound units, output smoothness reflects resolution effects.

**Theoretical Resolution.** Theoretical resolution, sometimes called *nominal resolution* applies only to linear wirewound potentiometers and *assumes* that the moveable contact can be set to any given turn of resistance wire. Fig. 2-26 shows an example of this type of wirewound element. If N represents the number of active turns in the element, then the theoretical resolu-



Fig. 2-26 Linear wirewound potentiometer element



tion is given in percent by the following formula:

$$\text{Theoretical Resolution } \% = \frac{1}{N} \times 100$$

The active turns are those turns between the termination tabs which contribute to the potentiometer's total resistance. The larger the number of turns, the better or *lower* the theoretical resolution. This also means that, for a given potentiometer construction, the higher resistance values will have a better theoretical resolution because more turns of a smaller diameter wire are used in the element.

As examples, consider a typical wirewound adjustment potentiometer. For a TR value of 1000 ohms, there are approximately 172 turns of wire in the element so the theoretical resolution is 0.58%. If a unit of the same style were constructed for a TR of 20,000 ohms, the element would require about 400 turns, yielding a theoretical resolution of 0.25%.

**Travel Resolution.** Travel resolution, applicable to wirewound potentiometers only, is the maximum movement of the mechanical input in one direction required to produce an incremental step in the output voltage. For a rotating input it will be specified in degrees but in the case of a linear actuating shaft it will be in thousandths of an inch. This parameter is specified without regard to wiper location on the element.

The typical output of a wirewound potentiometer is a staircase pattern in which the output voltage remains relatively constant for a small amount of wiper travel, then it suddenly changes. Fig. 2-27 is an expanded portion of this output voltage vs. wiper travel pattern. Travel resolution, unlike theoretical resolution, is a measurable output response.

As shown in Fig. 2-27, travel resolution and voltage resolution are related. Since the output

voltage increment is of major concern in most applications, voltage resolution, rather than travel resolution, is specified.

**Voltage Resolution.** Voltage resolution is defined as the greatest incremental change in output voltage in any portion of the resistance element with movement of the mechanical input in one direction. This parameter is applied only to wirewound units.

Voltage resolution is easily seen from the expanded graph in Fig. 2-27. It is the greatest step height in output voltage resulting from a corresponding change in wiper position.

A circuit suitable for voltage resolution demonstration is shown in Fig. 2-28. A stable voltage source,  $E_1$ , supplies 10V as an input to the potentiometer. The output voltage is fed to a load resistor,  $R_L$ , and through a high pass filter to a strip-chart recorder.  $R_L$  need not be included in the circuit unless it is specified by the end user of the potentiometer. Since  $R_L$  is rarely used, the following discussion assumes it is *not* present in the demonstration circuit.

The characteristics of the filter must be such that the charge on the capacitor,  $C$ , is allowed to reach a near-steady-state value within the time required for the wiper to move from one turn of resistance wire to the next. The output signal fed to the recorder will be a series of pulses indicating each time a new turn and, hence, a new voltage level is encountered. Fig. 2-29 illustrates the input and output waveforms.

In order to demonstrate these electrical parameters, the time interval,  $t$ , between voltage steps,  $e$ , may be calculated from the theoretical resolution and the travel time required to traverse the entire electrical length.

$$t = \frac{\text{Travel Time} \times \text{Theoretical Resolution}}{100}$$

$t$  = time interval

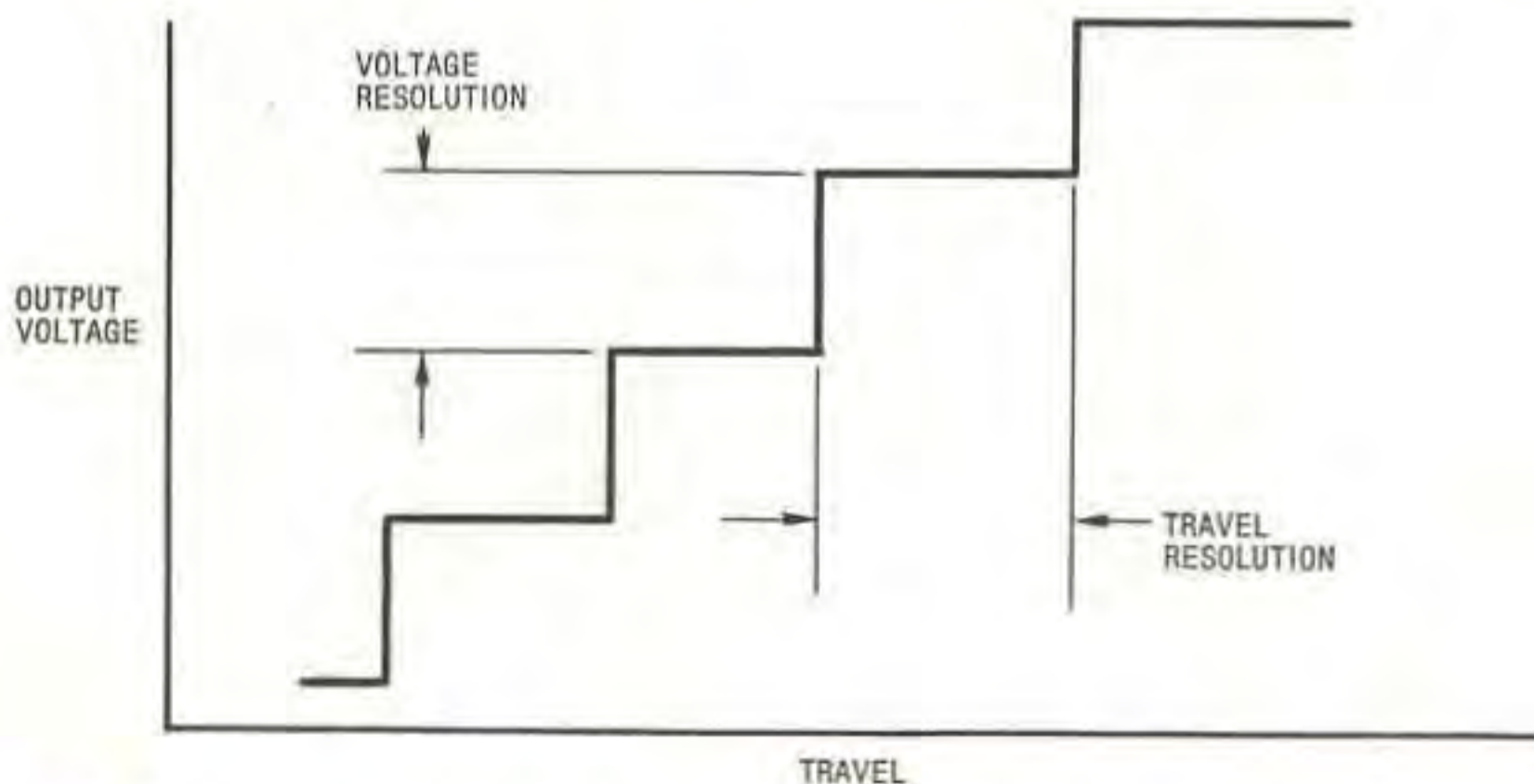

Fig. 2-27 Output voltage vs. travel — illustrating theoretical voltage and travel resolution



Division by 100 is necessary because the theoretical resolution is given in percent. The time interval,  $t$ , will be in the same units chosen to express the travel time.

The input resistance of the recorder,  $R_R$ , (Fig.

2-28) must be at least 10 times the total resistance of the potentiometer in order to prevent loading errors. It may be that the actual input resistance of the recorder is very large and  $R_R$  represents an external shunting resistance.

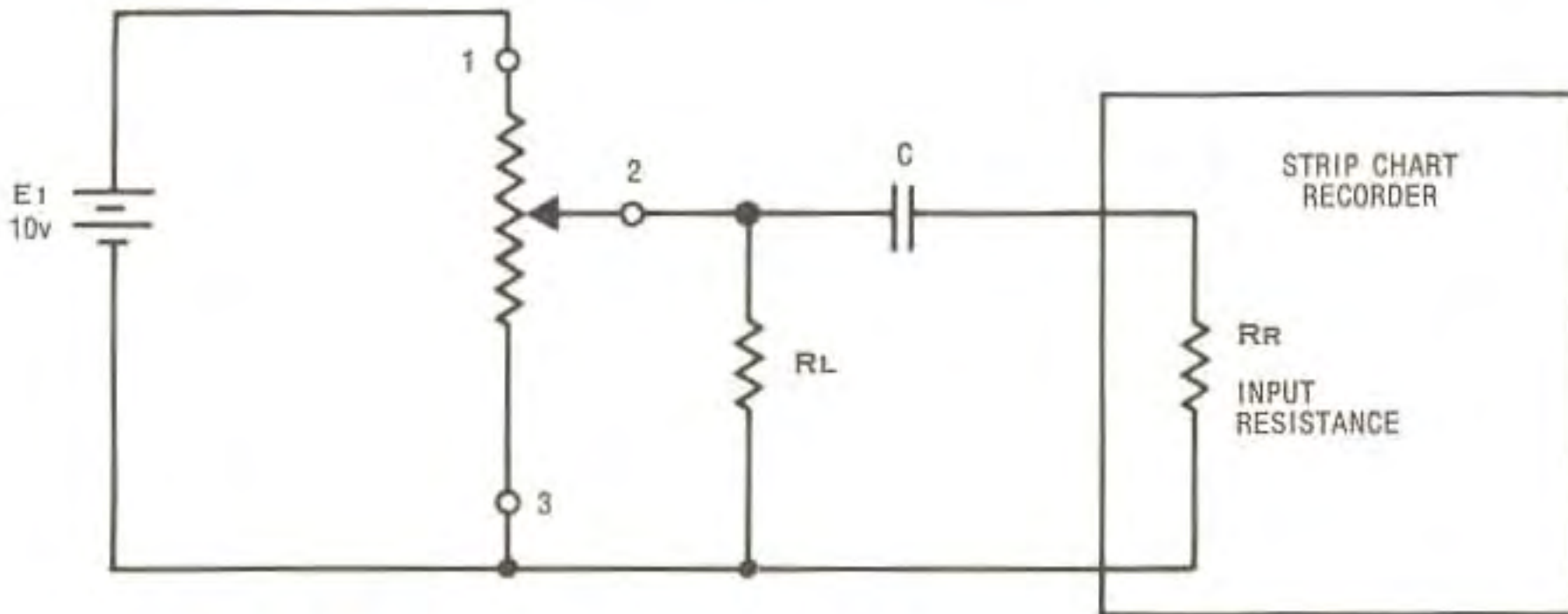

Fig. 2-28 Circuit configuration for demonstrating voltage resolution

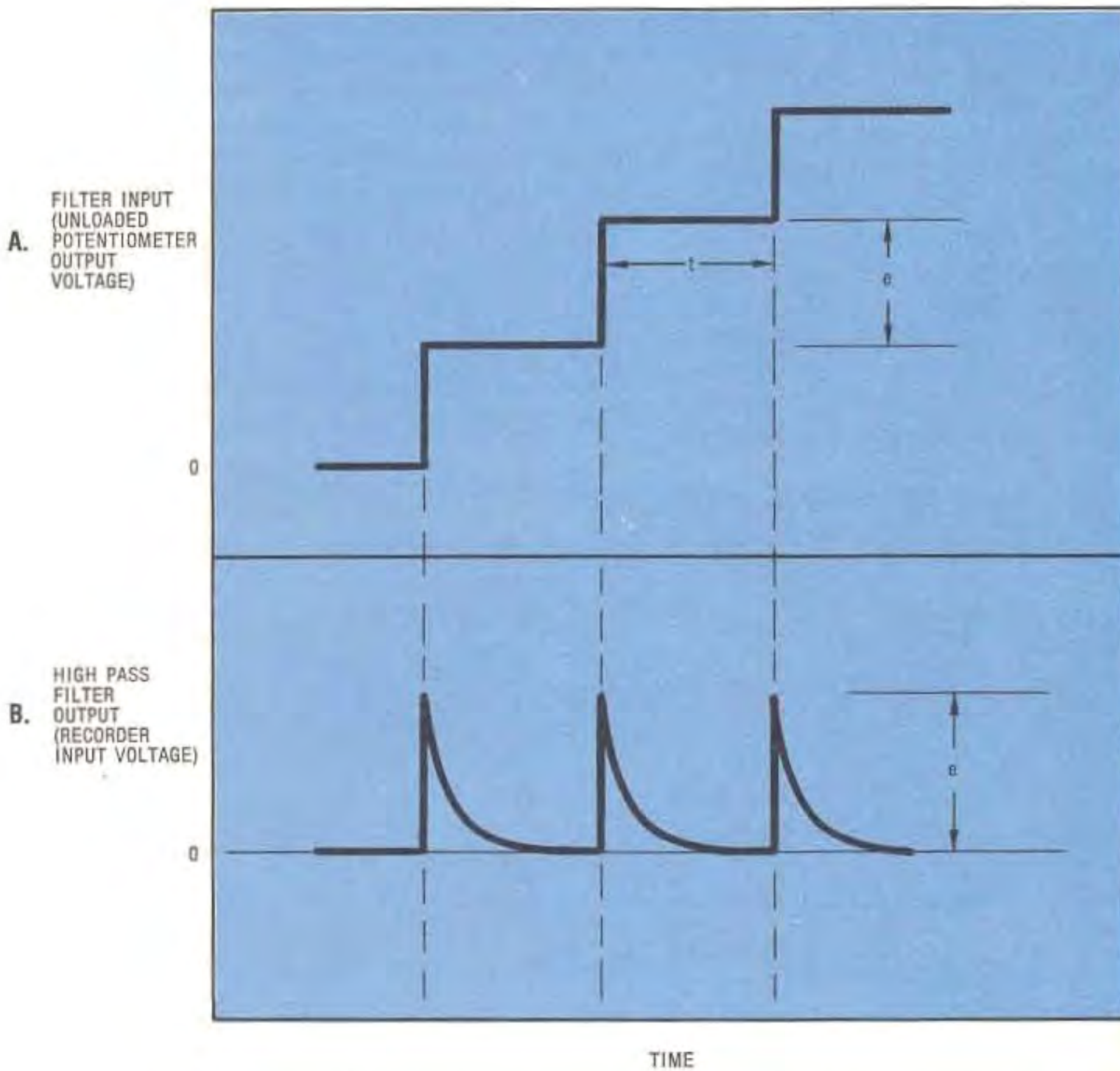

Fig. 2-29 Input and output voltage waveforms for the high pass filter,  $R_R C$ , in Fig. 2-28



The time constant of the filter approximated by  $R_R C$ , should be made much less than the time interval,  $t$ . Industry standards recommend that  $R_R C$  be one tenth the value of  $t$ , but a ratio as small as 1 to 5 will contribute negligible error. Thus, the value of the filter capacitance may be calculated from the formula:

$$C = \frac{t}{5R_R}$$

If  $t$  is expressed in seconds and  $R_R$  in megohms,  $C$  will be given in microfarads.

The response of the recorder must be faster than the time constant of the filter, or the true peak value of the output pulse will not be displayed. If a slow response recorder is the only instrument available for demonstration purposes, it may be necessary to move the potentiometer wiper very slowly.

The magnitude of voltage resolution is the ratio of the maximum voltage pulse seen by the recorder to the total input voltage. It is usually expressed in percent. In general:

$$\text{Voltage Resolution \%} = \frac{\text{Max. Voltage Pulse}}{\text{Input Voltage}} \times 100$$

The maximum voltage pulse and input voltage must be expressed in like terms. For the circuit of Fig. 2-28 and the waveform of Fig. 2-29B:

$$\begin{aligned} \text{Voltage Resolution \%} &= \frac{e_{\max}}{10} \times 100 \\ &= 10e_{\max} \end{aligned}$$

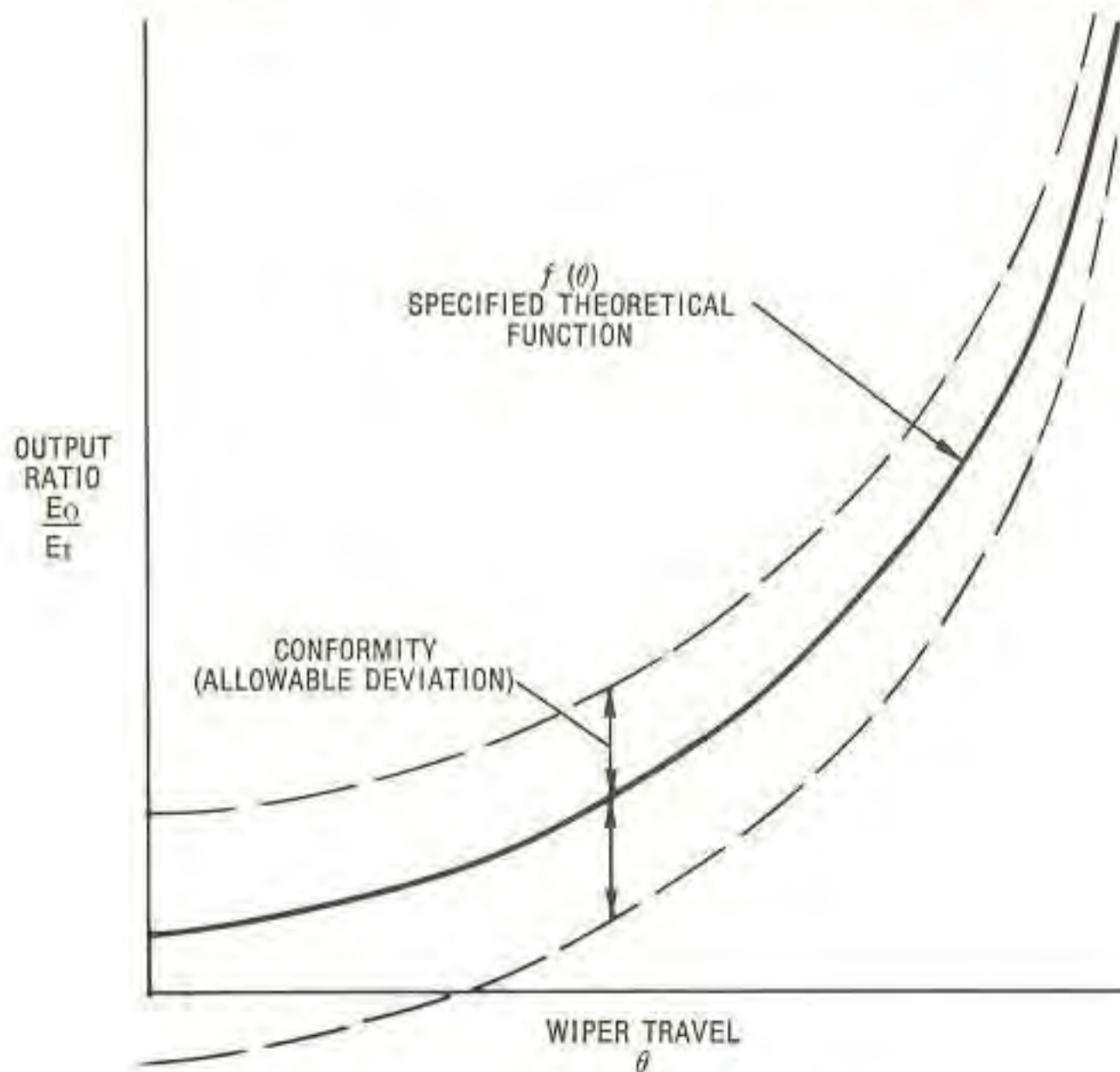

Fig. 2-30 Conformity

## CONFORMITY

Many precision and special applications of potentiometers require that the output voltage be some well defined nonlinear function of the wiper position and input voltage. Expressing this mathematically:

$$E_o = E_t f(\theta) \text{ or}$$

$$\frac{E_o}{E_t} = f(\theta)$$

where  $E_o$  represents the output voltage,  $E_t$  is the total input voltage, and  $f(\theta)$  represents the theoretical output function of the potentiometer.

It is impractical for a manufacturer to meet a given mathematical function specification (ideal output curve) exactly. The function is normally specified with a tolerance or deviation from the theoretical function. This allowable deviation of the output curve from a fully defined theoretical function is *conformity*. In other words, it is the tolerance or error band specified about the theoretical (ideal) output curve. This is shown in Fig. 2-30. Before discussing the parameters which are used to characterize conformity it is necessary to define several terms. The illustration of Fig. 2-31 presents a simple method of demonstrating the factors which affect conformity. In addition, Fig. 2-31 provides graphical representation of the following definitions:

*Total mechanical travel*, Fig. 2-31A, is the amount of angular input rotation  $\theta_M$  necessary



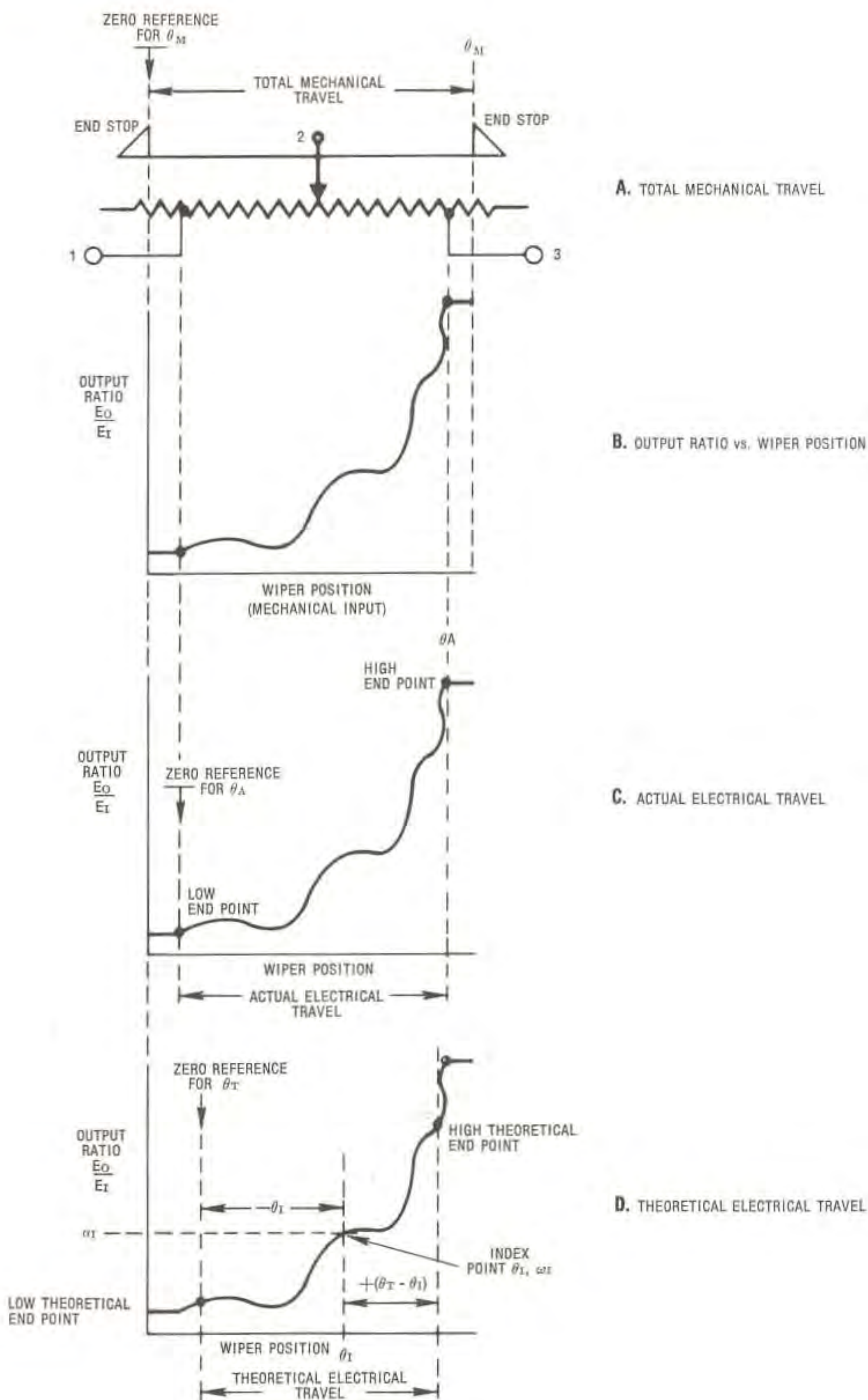

Fig. 2-31 Graphical representation of some important definitions



to move the wiper from one end stop to the other end stop. It is not necessary to use this term when referring to continuous rotation units since end stops are not provided. The output ratio at various wiper positions along the total mechanical travel can be measured and plotted as in Fig. 2-31B. A digital voltmeter with ratio capability is an excellent instrument for this purpose.

*Actual electrical travel*, is the total amount of angular input rotation,  $\theta_A$ , over which the output ratio actually varies. This travel range may be easily located by noting the high and low *end points* on the curve of Fig. 2-31B where the output ratio begins or ceases to vary. For the particular potentiometer being considered, these points are shown in Fig. 2-31C.

*Theoretical electrical travel*, is the amount of angular input rotation,  $\theta_T$ , defined as the operational range of the potentiometer. This travel range extends between the high and low *theoretical end points* as shown on the curve of Fig. 2-31D. The location of the theoretical electrical travel range is defined by an *index point*. This point is *always* on the output ratio curve. To locate the theoretical electrical travel range, it is only necessary to locate the theoretical end points. To do this, the potentiometer is adjusted until an output ratio of  $\alpha_I$  is obtained. The index point specification, clearly defines this output ratio to be  $\theta_I$  degrees of angular input. Therefore, the theoretical end points can be located by adjusting the potentiometer through angles of  $-\theta_I$  and  $+(\theta_T - \theta_I)$  from the end points.

In most cases when an index point is required it is specified by the potentiometer manufacturer. The angle and/or ratio of the index point will vary from unit to unit but the manufacturer indicates the index point coordinates on the potentiometer exterior. In some instances, system design may require the angle *or* ratio of the index point to be the same throughout a given quantity of potentiometers. In these cases, the end user specifies one of the index point coordinates and the manufacturer specifies the other coordinate.

Since the index point is always on the output ratio curve, the index point coordinates cannot be guaranteed identical for a given group of units. At least one coordinate, either input angle or output ratio, must vary from device to device.

To apply the above terms to an example, assume that a particular potentiometer has a *total mechanical travel* of  $352^\circ$  and an *index point* at 50% output ratio,  $170^\circ$  rotational input. This potentiometer might have an *actual electrical travel* of  $348^\circ$ , with *end points* at  $172^\circ$  and  $176^\circ$  on either side of the index point. The *theoretical*

*electrical travel* for the same unit could be  $0-340^\circ$  with *theoretical end points*  $170^\circ$  on either side of the index point.

The three travel ranges described above are defined in terms of end point location. In each case, the lower end point is referred to as the *zero reference* for the particular travel range being considered. Occasionally, it is necessary to refer to some particular wiper position. This is accomplished throughout this book by specifying an *angular travel distance*,  $\theta_W$ , from the zero reference of the travel range being considered.

Assume the potentiometer whose actual output is plotted in Fig. 2-31B was built to the theoretical function and conformity limits of Fig. 2-30. To evaluate this particular potentiometer's conformity, superimpose the actual output (Fig. 2-31B) on the theoretical function (Fig. 2-30). This composite is shown in Fig. 2-32.

Although the relationship shown in Fig. 2-32 is somewhat exaggerated, it does illustrate the following.

- 1) The index point by definition is always on the actual curve.
- 2) Zero output change may occur for a small wiper movement.
- 3) Output response may be opposite to the expected response.
- 4) It is also possible that the same exact output could be obtained at two different positions of travel.

At first glance, the upper and lower conformity limits (shown by broken lines in Fig. 2-30) seem to be closer together at the top end. Remember, it is the *vertical deviation* (the change in output voltage) which is being described. Actually, the vertical spacing on the conformity limits is constant.

To summarize this demonstration of conformity:

- 1) Make a plot of *theoretical* output function of voltage ratio,  $\frac{E_0}{E_1}$ , vs. wiper position,  $\theta_W$ .
- 2) Measure the *actual* output of a particular potentiometer and construct a graph of voltage ratio  $\frac{E_0}{E_1}$  vs. wiper position,  $\theta_W$ .
- 3) Evaluate the *conformance* of the actual response to the theoretical response.

If conformity is included in the mathematical relationship previously given, the formula may be written:

$$\frac{E_0}{E_1} = f(\theta) + K$$



where  $K$  represents the conformity and is usually specified in terms of a percentage of the total input voltage.

Generally, it is convenient to express the potentiometer's output to input function in terms of a ratio of wiper position,  $\theta_w$ , to the maximum theoretical electrical travel,  $\theta_T$ , or:

$$\frac{E_o}{E_i} = f\left(\frac{\theta_w}{\theta_T}\right) + K$$

By its definition, this mathematical relationship is the *transfer function* of the potentiometer.

### ABSOLUTE CONFORMITY

*Absolute conformity* is defined as the greatest *actual* deviation of a potentiometer's output from the specified theoretical transfer function. It is expressed as a percentage of the total applied input voltage and measured over the theoretical electrical travel. An index point of reference is required.

The drawing of Fig. 2-32 illustrates absolute conformity. Note that for some values of travel, the actual output is higher than that predicted from the theoretical curve, while it may be lower for other values of travel. Absolute con-

formity for this particular potentiometer is the maximum vertical deviation of the actual response from the theoretical curve. This happens to occur at about mid-position for this example, but could happen anywhere along the curve for another unit.

### LINEARITY

Linearity is a specific type of conformity where the theoretical function (ideal output curve) is a straight line. A generalized mathematical representation of this function is:

$$\frac{E_o}{E_i} = m f(\theta) + b + k$$

- Where:  $E_o$  is output voltage.
- $E_i$  is input voltage.
- $m$  is the slope.
- $b$  is the slope intercept at zero travel.
- $\theta$  is the travel.
- $k$  is the linearity.

The demonstration method previously described for conformity, is perfectly suited for linearity demonstration.

Linearity is specified in one of 4 ways: *absolute, independent, zero based* or *terminal based*.

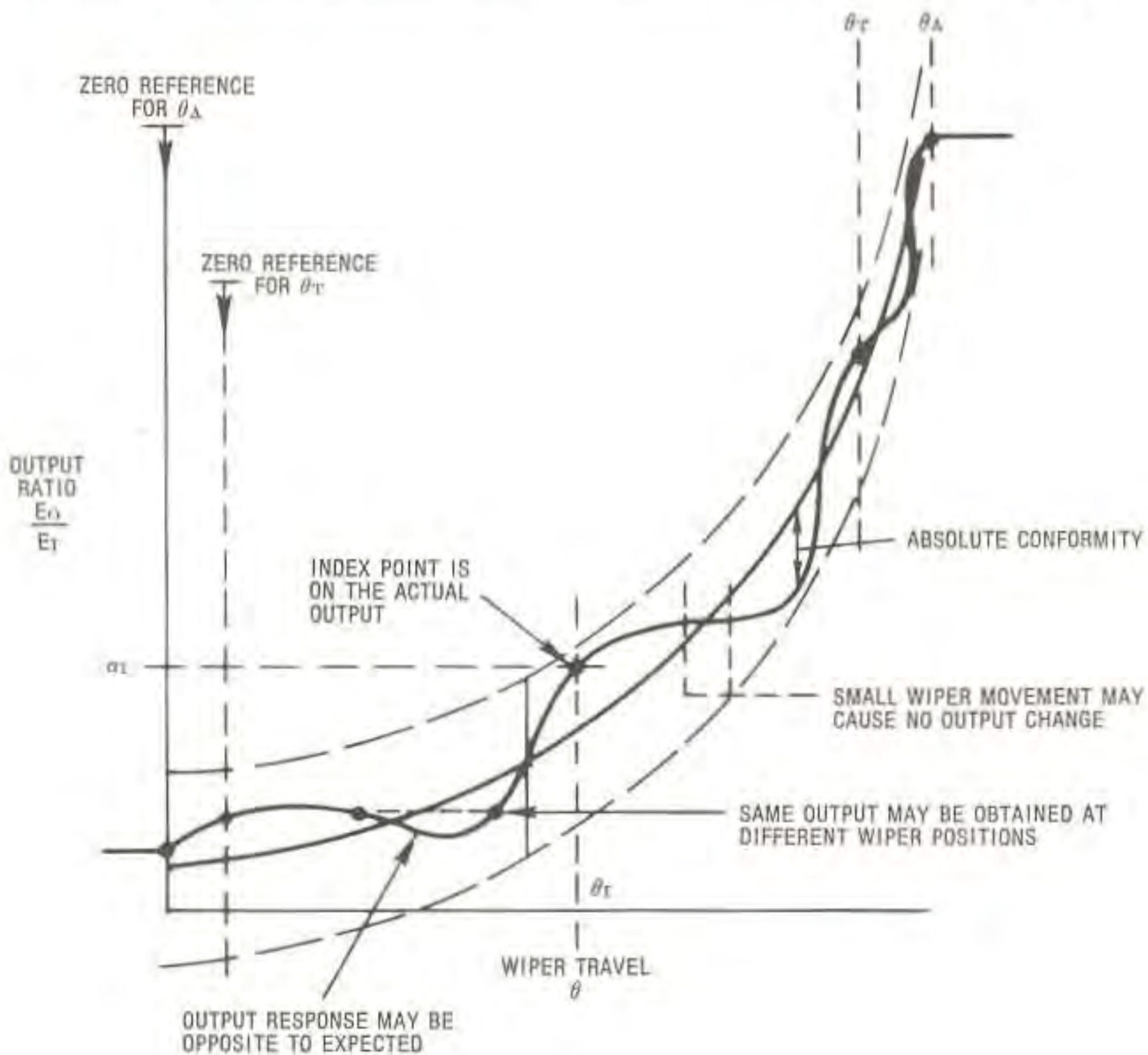

Fig. 2-32 Evaluation of conformity



These specifications differ only in the method of output curve evaluation. Note that the following explanation of each linearity evaluates the actual output curve of one particular potentiometer. This output curve is shown in Fig. 2-33.

**Absolute Linearity.** Absolute linearity is the maximum permissible deviation of the actual output curve from a fully defined straight reference line. It is expressed as a percentage of the total applied input voltage and measured over the theoretical electrical travel. An index point on the actual output is required.

The straight reference line representing the ideal theoretical output ratio is fully defined by two points. Unless otherwise specified, these points are: (1) Zero travel,  $\theta_w=0$ , with an output ratio of 0 and (2) full theoretical electrical travel,  $\theta_w=\theta_T$ , with an output ratio of 1.

The illustration of Fig. 2-34 shows the conditions necessary to define absolute linearity. In this example, the lower limit of the output ratio (point X,  $\theta_w=0$ ) is specified as a value slightly greater than zero. The upper limit of the output ratio, (point Y,  $\theta_w=\theta_T$ ) is specified as 1.

The reference line for absolute linearity may be described mathematically as:

$$\frac{E_o}{E_i} = m \left( \frac{\theta_w}{\theta_T} \right) + b$$

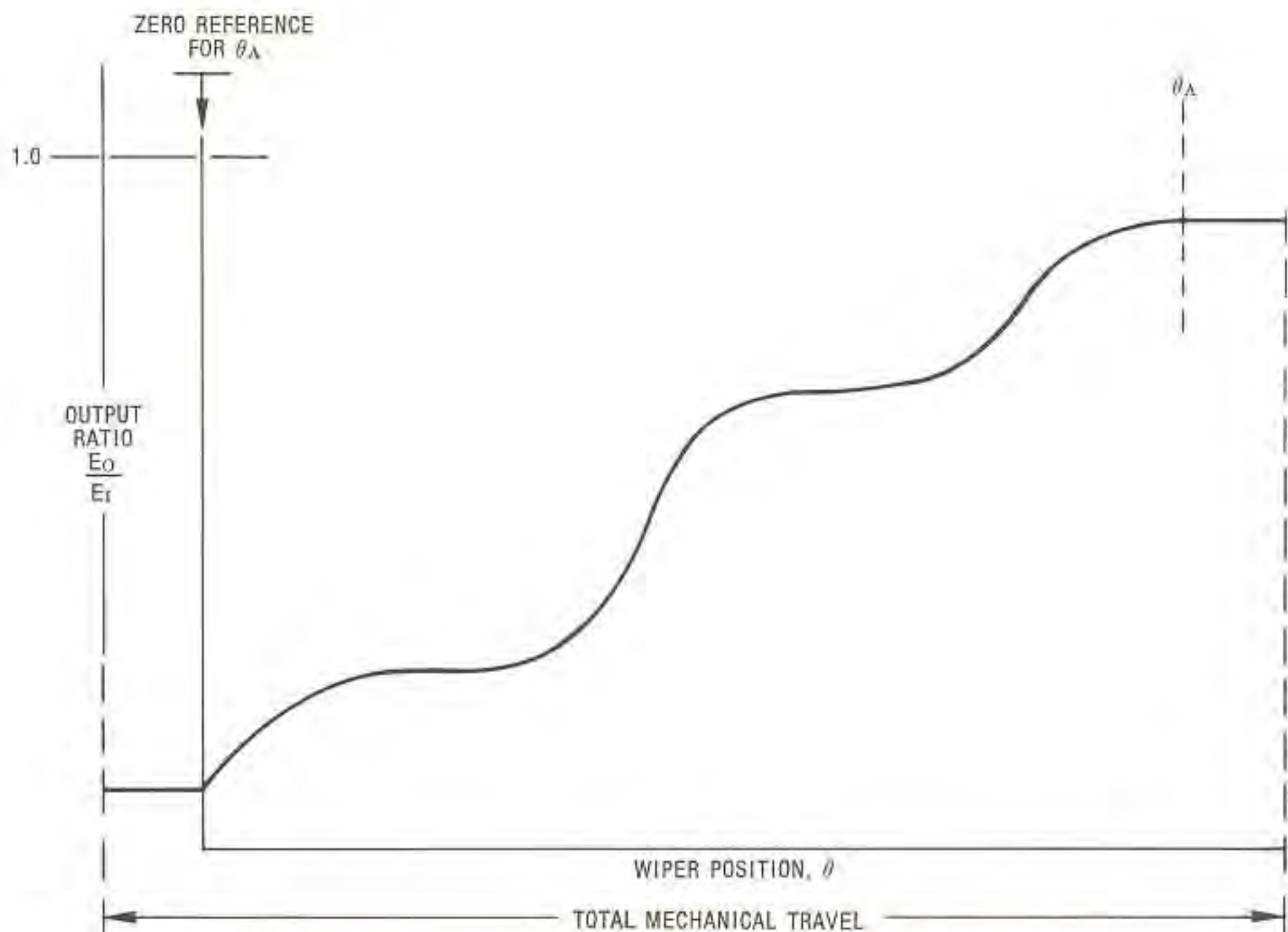

Fig. 2-33 Actual output curve for one particular potentiometer

In the specific example of Fig. 2-34, the lower limit of the output ratio is specified as 0.05. Therefore, the value of  $b$  (intercept) must also be 0.05. In addition, the upper limit of the output ratio is 1 when  $\frac{\theta_w}{\theta_T} = 1.0$ . To determine the slope, substitute these upper and lower limit values in the general equation and solve for  $m$ .

$$\frac{E_o}{E_i} = m \left( \frac{\theta_w}{\theta_T} \right) + b$$

$$1 = m(1) + .05$$

$$m = \frac{1 - .05}{1}$$

$$m = .95$$

For this example, the index point happens to be at an output ratio,  $\frac{E_o}{E_i}$ , of 0.5 and wiper travel,  $\theta_w$ , of  $170^\circ$ .

In order to meet the specification, the actual output curve of the potentiometer being evaluated must be within the upper and lower limits defined by absolute linearity. This means the maximum vertical difference (voltage ratio) between the actual output curve and the theoretical reference line must be within the  $\pm k$  envelope. Typical values of absolute linearity,



expressed in percent of total input voltage, range from .2 to 1.0%.

Absolute linearity is the most precise definition of potentiometer output because the greatest number of linearity parameters are controlled. This is the primary advantage of absolute linearity. The methods used to manufacture to these parameters, however, cause *absolute* linearity to be the most expensive of the four linearities.

In Chapter 4, approaches are discussed for achieving absolute linearity performance from more loosely specified (lower cost) linearities by adding adjustment potentiometers. This may be an economical alternative.

**Independent Linearity.** Independent linearity is the maximum permissible deviation of the actual output curve from a reference line. The slope and position of this reference line are chosen to minimize deviations over all or a portion of the actual electrical travel. In other words, the choice of the values for the slope and intercept are such as to minimize the linearity error. Thus, the reference line is placed for best straight line fit through the actual output curve. Further restrictions may be imposed on the limits of slope and intercept by additionally specifying the range of permissible end output ratios.

Fig. 2-35 illustrates conditions necessary to define independent linearity. The exaggerated wavy line represents the actual output ratio, and is measured over the total *actual* electrical travel. The reference line is positioned on the output curve, without regard to slope and intercept, so the positive and negative deviations or linearity errors are minimized.

The reference line is expressed by the mathematical equation:

$$\frac{E_o}{E_i} = m \left( \frac{\theta_w}{\theta_A} \right) + b$$

where  $m$  is an *unspecified* slope,  $\theta_A$  is the actual electrical travel,  $b$  is the *unspecified* intercept value of the output ratio at  $\theta_w=0$ .

The independent linearity specification, as shown by the broken lines, are parallel to the reference line and spaced above and below it. These show the allowable output ratio deviation from the theoretical reference line. Typical values of independent linearity, expressed in percent of total input voltage, range from .05 to .20%.

It is more common to specify independent rather than absolute linearity because it gives the tightest tolerance specification for a given cost. The major difference between independent linearity and absolute linearity is that the reference line for independent linearity is positioned

to minimize the linearity error. Therefore, the specification of independent linearity should be carefully evaluated to assure interchangeability of devices in a given application.

The determination of actual electrical travel depends upon a clear definition of end points. Generally, there is no problem with wirewound elements, but accurate determination of end points for nonwirewound elements can be quite difficult. In many instances, the output in the region near the end of the nonwirewound element exhibits an abrupt step function. In other cases, the function may be irregular and quite nonlinear with no clearly definable end point.

Irregularities at the end points present little difficulty in most applications where only the middle 80 to 90 percent of travel is used. It becomes necessary, however, to deal with the problem in order to make the linearity specifications meaningful for nonwirewound potentiometers.

There are two possible approaches to characterizing linearity in nonwirewound potentiometers. The first method utilizes an index point of reference while the second merely defines the location of end points.

Fig. 2-36 illustrates the first approach. An index point must be specified as was done for absolute linearity. The travel is presented in terms of a total theoretical electrical travel with respect to the reference index point. Linearity is then determined by constructing a reference line through the actual output curve to minimize the deviations of the actual output from the reference or theoretical line. This best straight line fit is the same as used for independent linearity of wirewound units.

The second approach to specification of independent linearity for nonwirewound potentiometers, Fig. 2-37, defines the end points in terms of specific output ratios. Otherwise, it uses the same basic method as with wirewound potentiometers. A typical set of end points is specified as that travel position where the output voltage ratio is exactly .01 and .99 for the low and high end points respectively. This allows easy measurement of the actual electrical travel, and the independent linearity may be evaluated in the same manner as for wirewound potentiometers.

**Zero Based Linearity.** Zero based linearity is a special case of independent linearity where the zero travel end of the theoretical reference line is specified. In this case, the theoretical reference line extends over the actual electrical travel. Zero based linearity is the maximum resulting deviation of the actual output from the straight reference line. This straight line is drawn through the specified minimum output voltage



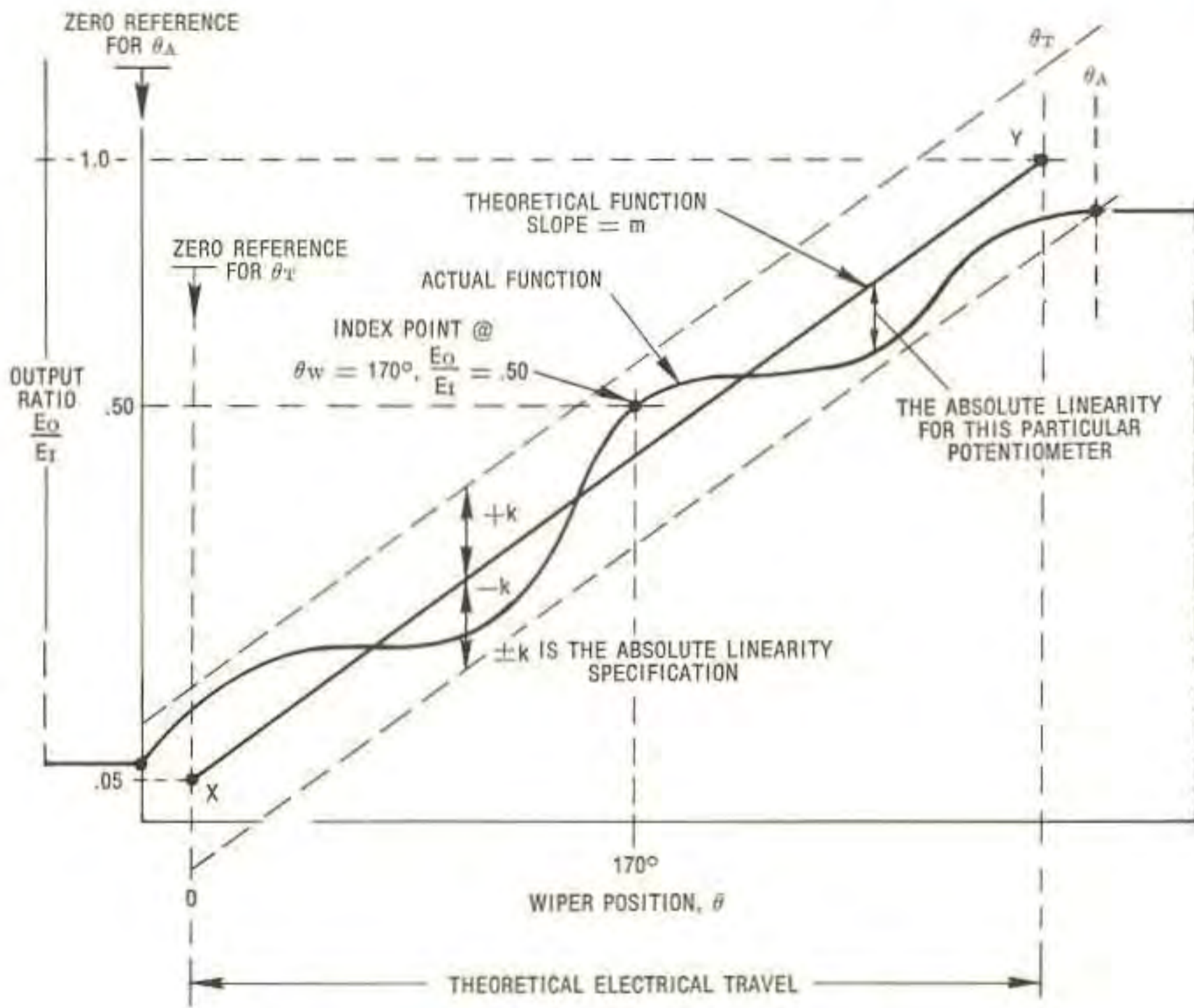

Fig. 2-34 Absolute linearity

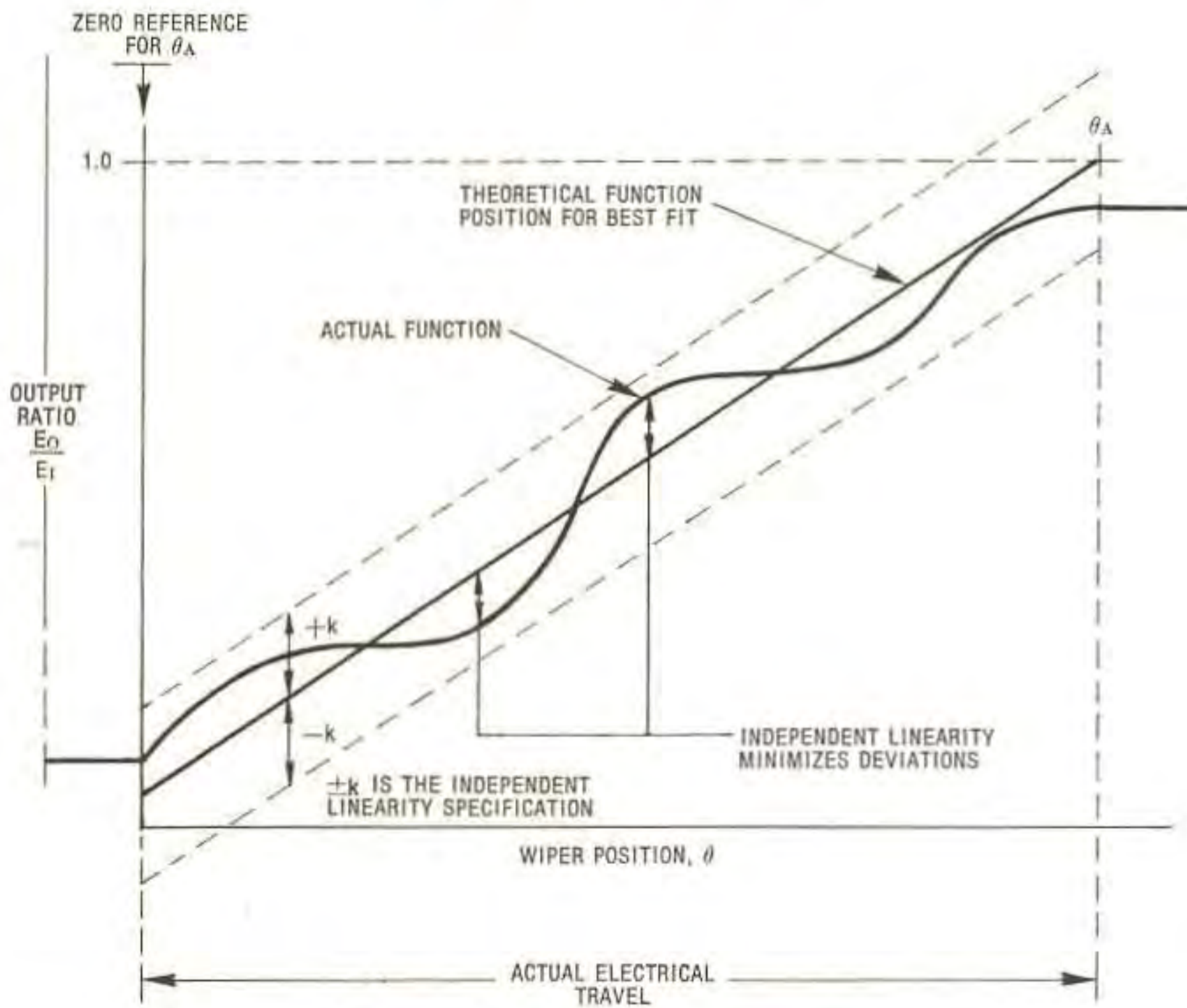

Fig. 2-35 Independent linearity



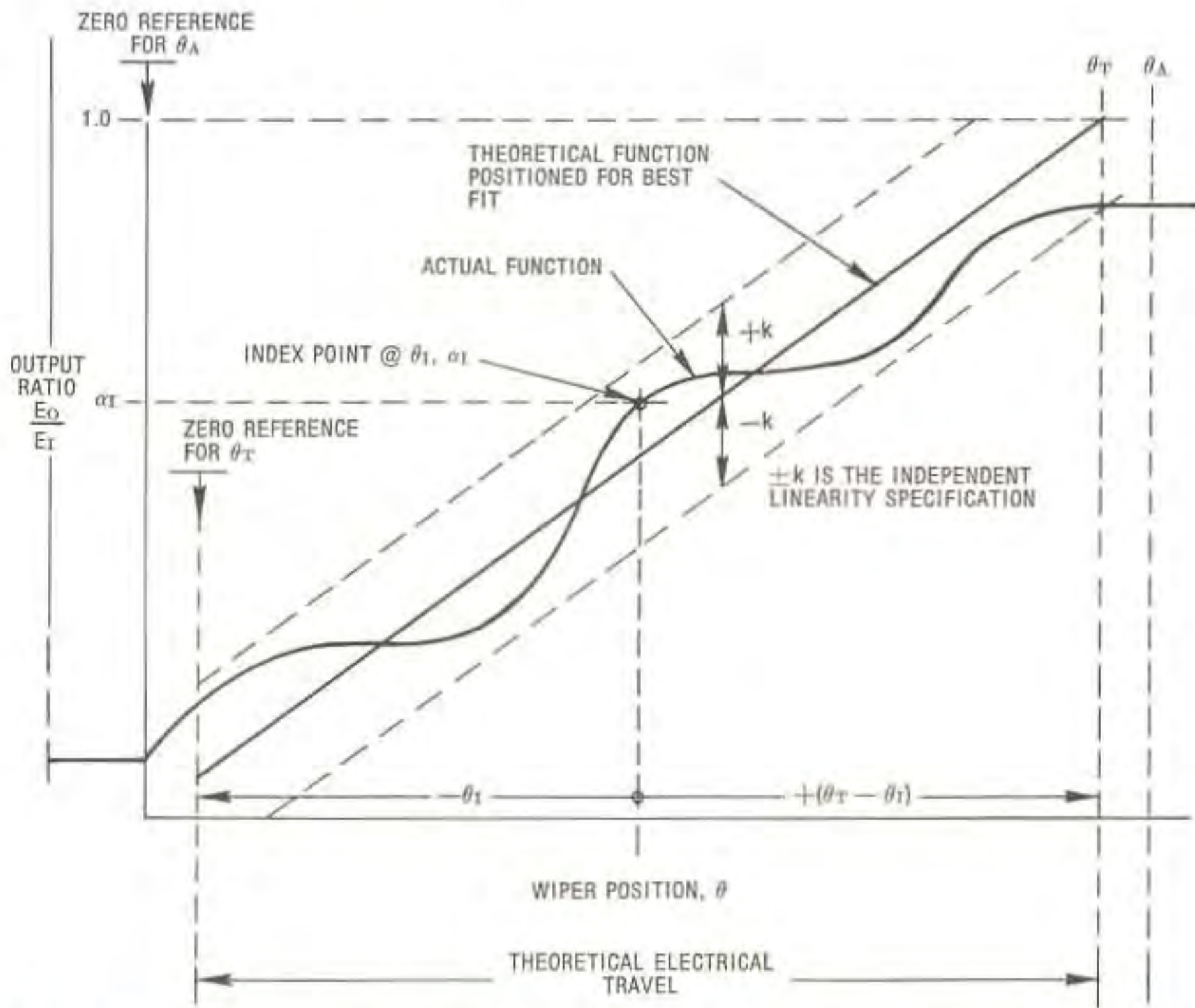

Fig. 2-36 A method to evaluate independent linearity for a non-wirewound potentiometer

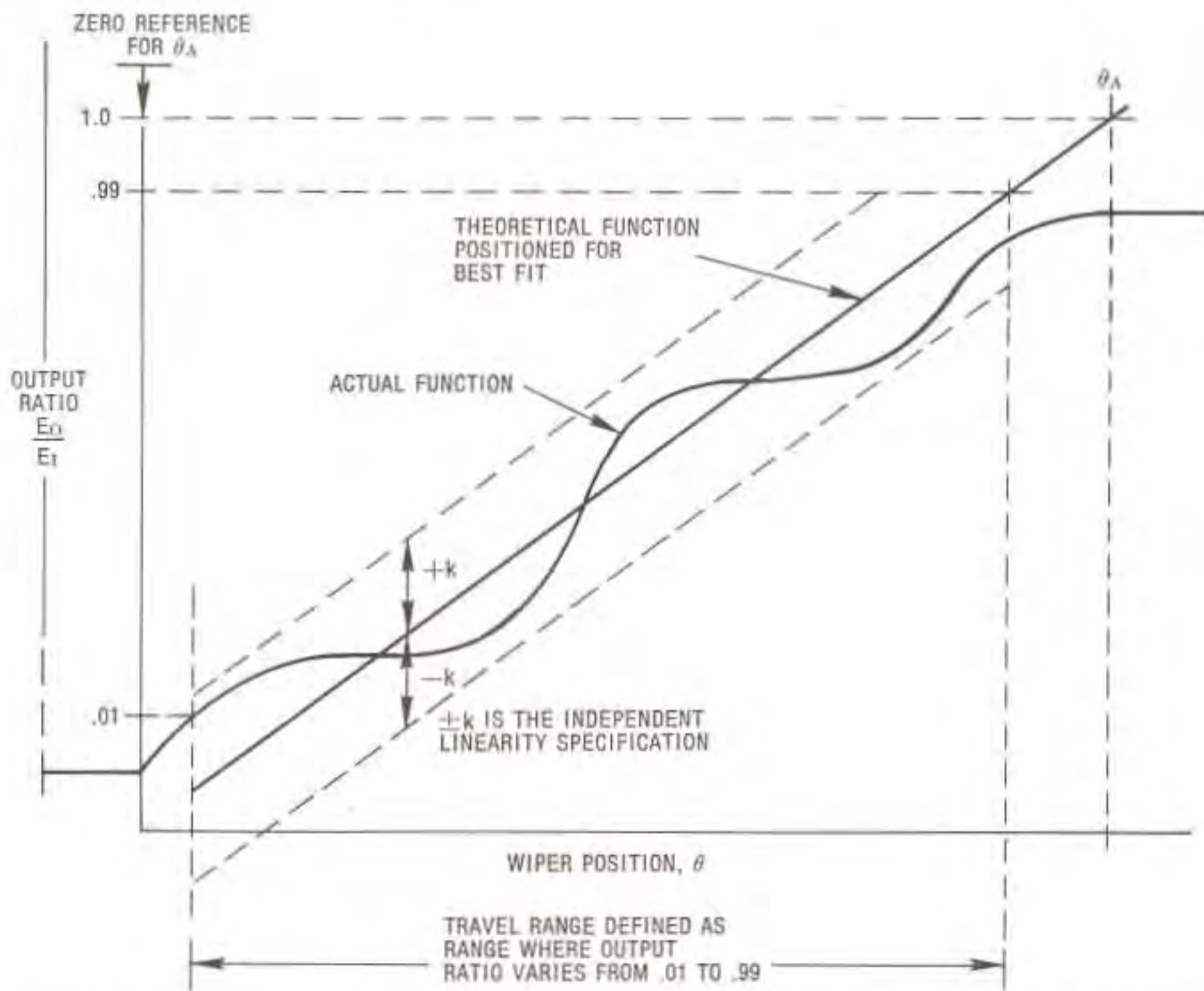

Fig. 2-37 A method to evaluate independent linearity for a non-wirewound potentiometer



ratio with a slope chosen to minimize deviations from the actual output.

Zero based linearity, is expressed as a percentage of total input voltage. Any specified low end output voltage ratio may be used to define the location of the zero travel point of reference. However, unless otherwise stated, the specified value of minimum output voltage ratio is assumed to be zero.

Fig. 2-38 presents the conditions of a zero based linearity specification. For this example, the minimum output voltage ratio is specified as 0%. Note that the transfer functions of both the actual potentiometer output and the theoretical reference line are based upon the *actual* electrical travel. The slope of the reference line is chosen as the best straight line fit in order to reduce the maximum deviations of the actual transfer function from the reference. If an additional specification limits the range of the maximum output voltage ratio, then the range of slope permissible will also be limited.

The mathematical equation describing the actual transfer function is:

$$\frac{E_o}{E_i} = m \left( \frac{\theta_w}{\theta_A} \right) + b + k$$

where  $m$  is the unspecified slope whose value is chosen to minimize deviations for a specific potentiometer,  $b$  is the specified intercept value determined by the minimum output voltage ratio specification,  $\theta_w$  is wiper position,  $\theta_A$  is the actual electrical travel for a specific unit, and  $k$  is the linearity.

Zero based linearity is used where: (1) close control of the transfer function is necessary at lower output ratios, (2) greater flexibility of the slope and hence, the transfer function at higher output ratios is permissible.

In many applications, performance very closely resembling that obtained with a costly tight absolute linearity specification may be achieved with a lower cost zero based linearity specification. This is possible when it is used with an adjustment potentiometer to control the overall system gain. Simply stated, an adjustment potentiometer can be used to shift the output (slope) of a precision potentiometer to fit within maximum output limits.

**Terminal Based Linearity.** A linearity specification sometimes used with wirewound potentiometers is terminal based linearity. It is the maximum deviation of the actual output from a straight reference line drawn through minimum and maximum end points. These points are separated by the actual electrical travel. Unless otherwise stated, the minimum and maximum output ratios are, respectively, zero and

100% of the total applied input voltage. Terminal based linearity is expressed as a percentage of the total applied input voltage.

Terminal based linearity is very much like the absolute linearity except for the definition of reference line end locations as related to travel. With absolute linearity, travel is related to a theoretical movement from a reference index point. The terminal based linearity specification uses actual electrical travel with the end locations on the reference line corresponding to the actual end points of the potentiometer.

Fig. 2-39 shows the requirements for terminal based linearity. For the example here, it is assumed that the minimum and maximum output voltage ratios are given as a basic part of the linearity specification. The 0% and 100% travel limits are implicit.

The reference line for the theoretical output is established by defining two points, X and Y. Point X is the minimum output voltage ratio in the example of Fig. 2-39. It is a travel distance of zero from the lower end point. The second point, Y, is the maximum output voltage ratio in the example and the travel distance is the actual electrical travel. The reference line is constructed with a straight line through the two points, X and Y.

The difference between absolute and terminal based linearity is in the use of *theoretical* electrical travel in the former case and *actual* electrical travel in the latter. There is no significant difference between absolute and terminal based linearity in those applications where the overall system gain may be adjusted to compensate for a variation in the value of the actual electrical travel from one unit to the next. On the other hand, the same degree of interchangeability cannot be expected from a terminal based linearity specification as there would be with an absolute linearity specification.

The actual output function of a given potentiometer purchased under a terminal based linearity specification has the mathematical form:

$$\frac{E_o}{E_i} = m \left( \frac{\theta_w}{\theta_A} \right) + b + k$$

where  $m$  is a specified slope of the theoretical reference line,  $b$  is the intercept value established by the specified minimum output voltage ratio,  $\theta_w$  is wiper position,  $\theta_A$  is the actual electrical travel for a given potentiometer, and  $k$  is the linearity error.

## POWER RATING

Power rating is the maximum heat that can be dissipated by a potentiometer under specified conditions with certain performance require-



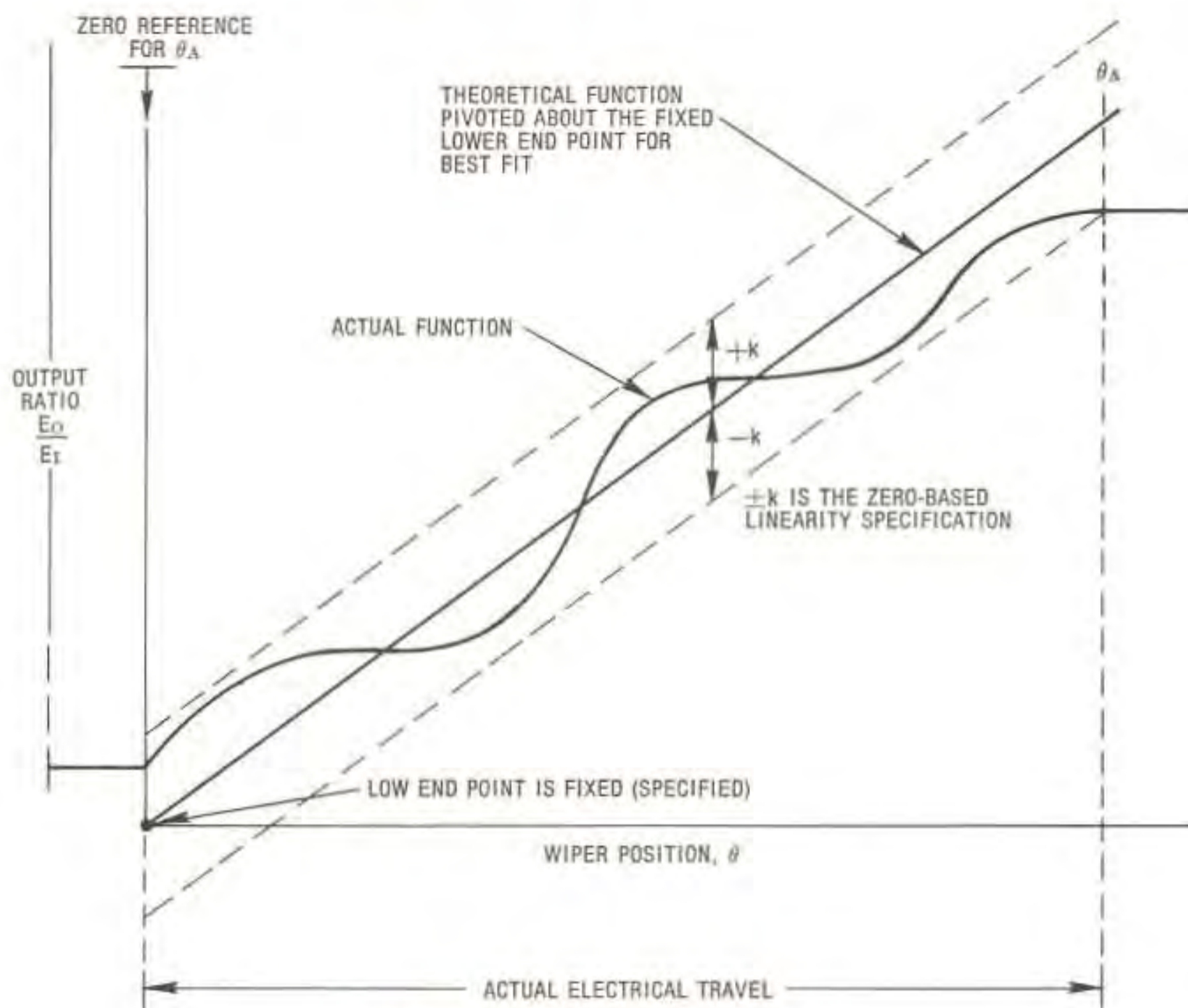

Fig. 2-38 Zero based linearity

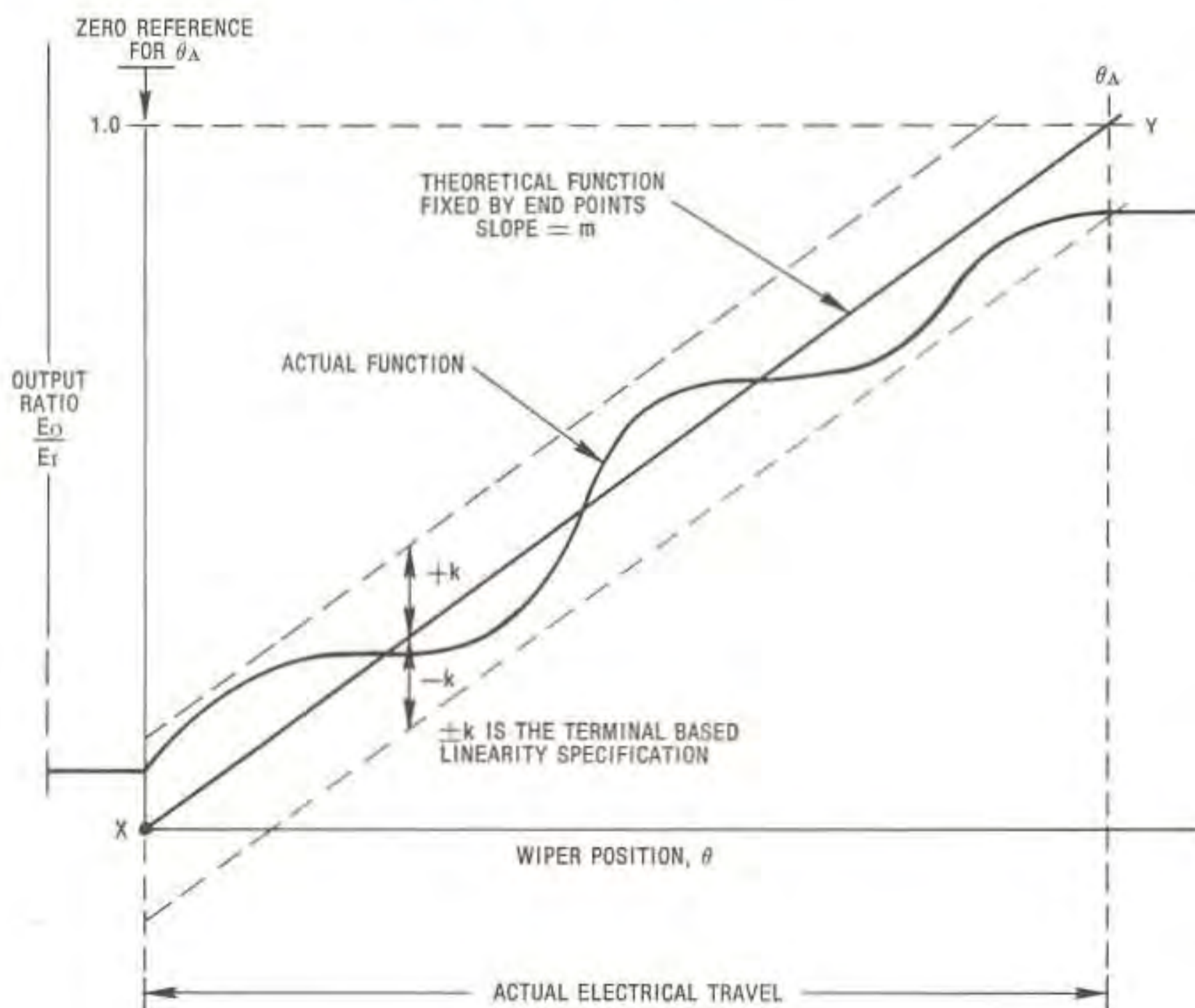

Fig. 2-39 Terminal based linearity



ments. Heat (or power) dissipation is the result of current passing through a resistance. Mathematically:

$$P = I^2R$$

or

$$P = \frac{E^2}{R}$$

where  $P$  is the power dissipation in watts and  $R$  is the total resistance in ohms.  $I$  is the total current in amps flowing through the resistance,  $R$ , and  $E$  is the total voltage drop expressed in volts, across the resistance,  $R$ .

The useful life of a given potentiometer is directly related to the maximum temperature allowed in the interior of the unit. Above a certain internal temperature, insulating materials begin to degrade. A maximum power rating indicates to the circuit designer just how much power may be safely dissipated without harm to the device.

The manner in which a given potentiometer is applied will affect the maximum permissible power dissipation for a given power rating. A detailed explanation of power rating is beyond the scope of this chapter. For a complete analysis relative to applications, refer to Chapter 3.

## INSULATION RESISTANCE, IR

Insulation resistance, IR, is the resistance presented to a dc voltage applied between the potentiometer terminals and all other external conducting parts such as shaft, housing, and

mounting hardware. It may be thought of as a measure of the electrical leakage between the electrical portion of a potentiometer and other conductive parts of the potentiometer. In the case of ganged (multiple section) units, the insulation resistance specification is also applicable to the resistance between sections.

A commercial megohmmeter with an internal source voltage of the proper value, normally 500v dc, may be used to measure insulation resistance. One lead is connected to all the terminals of the potentiometer and the other lead is connected to the case, shaft, bushing, or other metal parts. Fig. 2-40 illustrates a basic demonstration circuit for insulation resistance.

The power supply must be current limited to prevent damage to it or the electrometer in the case of an unexpected internal short in the potentiometer.

The value of insulation resistance,  $R_1$ , is determined by the applied voltage,  $E$ , and the resulting current,  $I$ :

$$R_1 = \frac{E}{I}$$

Typical values of insulation resistance are 1,000 megohms and higher. The insulation resistance parameter, as normally given, refers to bulk leakage resistance under dry operating conditions. Actual equivalent leakage resistance may be much lower (worse) in a given application due to surface leakage paths encouraged by a combination of contaminants and moisture.

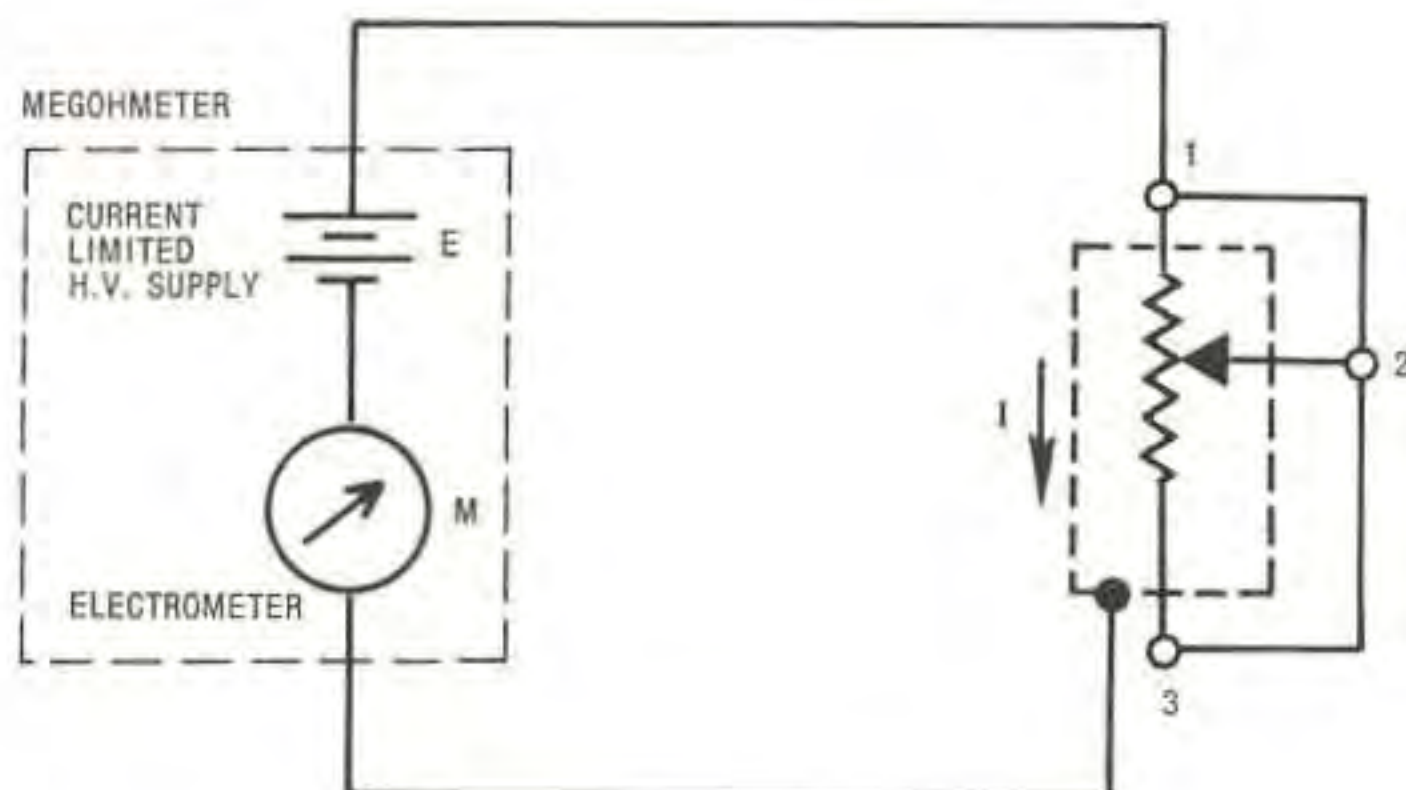

Fig. 2-40 Circuit configuration for demonstration of insulation resistance



## POTENTIOMETER ELECTRICAL PARAMETERS SUMMARY

APPLIES TO:			PARAMETER NAME	PAGE	BRIEF DEFINITION	DEMONSTRATION CIRCUIT FIG.	TYPICAL VALUES OR SPECIFICATIONS
W/W	NON W/W	BOTH					
		●	Total Resistance, TR	18	The resistance between the end terminals	2-2	10 $\Omega$ nom. to 5 Meg $\Omega$ nom.
		●	Absolute Minimum Resistance, MR	18	The lowest value of resistance obtainable between the wiper and either end terminal	2-4	0.5 $\Omega$ max. 1.0% (of TR) max.
		●	End Resistance, ER	20	The value of resistance obtained between the wiper and end terminal with the wiper positioned against the adjacent end stop	2-4	2% or 1 $\Omega$ to 20 $\Omega$
		●	Minimum Voltage Ratio	20	The voltage ratio obtained with the wiper positioned to the Absolute Minimum Resistance	2-6	0.1% to 3.0%
		●	End Voltage Ratio	20	The voltage ratio obtained with the wiper positioned to the End Resistance	2-6	0 to 3.0%
		●	Contact Resistance, CR	22	The resistance of the wiper circuit from the wiper terminal to its ultimate contact with the element	2-8	.1 $\Omega$ to 2.0% (of TR)
	●		Contact Resistance Variation, CRV	26	The instantaneous change in Contact Resistance that may occur as a result of wiper movement	2-13	$\pm$ 1% (of TR) $\pm$ 3 $\Omega$
●			Equivalent Noise Resistance, ENR	28	Theoretical, lumped parameter resistance reflecting the magnitude of signal loss due to noise	2-19	100 $\Omega$ max.
	●		Output Smoothness, OS	30	The instantaneous variation in output voltage from the ideal output voltage with wiper in motion	2-21	$\pm$ 0.1% (of TR)
		●	Adjustability of Resistance, A	31	The accuracy to which the wiper can be positioned to an arbitrarily selected resistance value	2-23	$\pm$ 0.1% (of TR)
		●	Adjustability of Output Voltage Ratio	32	The accuracy to which the wiper can be positioned to an arbitrarily selected voltage ratio	2-24	$\pm$ 0.05% (of Full Scale voltage ratio)
		●	Temperature Coefficient, TC	33	The change in total resistance that may occur due to a change in ambient operating temperature	2-25	w/w: $\pm$ 50ppm/ $^{\circ}$ C Non w/w: $\pm$ 100 ppm/ $^{\circ}$ C
●			Resolution	34	A measure of the incremental changes in output voltage (or resistance) with wiper travel	2-28	0.01% (of TR) to 1.0% (of TR)
		●	Conformity	37	The allowable deviation of the actual output from a specified theoretical output function	2-30 2-31, 2-32	0.1% to 2.0%
		●	Linearity	40	The allowable deviation of the actual output from a specified, straight line, theoretical output function	2-33 thru 2-38	$\pm$ .05% to $\pm$ 1.0% (of Input Voltage)
		●	Insulation Resistance, IR	47	The resistance presented to a d.c. voltage applied between the terminals and all other external, conducting parts	2-40	1000 Meg $\Omega$ and higher

Fig. 2-41 A summary of electrical parameters





"Let knowledge grow from more to more."  
Alfred, Lord Tennyson

### INTRODUCTION

Potentiometers are used in many different applications including calibration adjustments, manual control functions, data input, level and sensitivity adjustments, and servo position feedback transducers. The list is almost endless. However, any specific application can be categorized into one of two operational modes — the *variable voltage divider* or the *variable current rheostat*.

This chapter will look at potentiometer applications from the elemental position. Mathematical derivations of response characteristics are based on a theoretical, ideal model. Ways to modify the two basic operational modes to achieve desired or improved performance are included. The significance of some of the potentiometer parameters are explained. For complete definition of parameters, refer to Chapter 2.

### VARIABLE VOLTAGE DIVIDER MODE

A resistive voltage divider provides an output voltage in reduced proportion to the voltage applied to its input. In its simplest form, it consists of two resistances in series. The input voltage is applied across the total circuit and the output voltage is developed across one of the individual resistances.

To construct a *variable* voltage divider, using the potentiometer, the resistive element is substituted for the two resistances of the fixed voltage divider. The wiper provides an adjustable output voltage. The basic circuit is shown in Fig. 3-1A. An input voltage  $E_I$  is applied

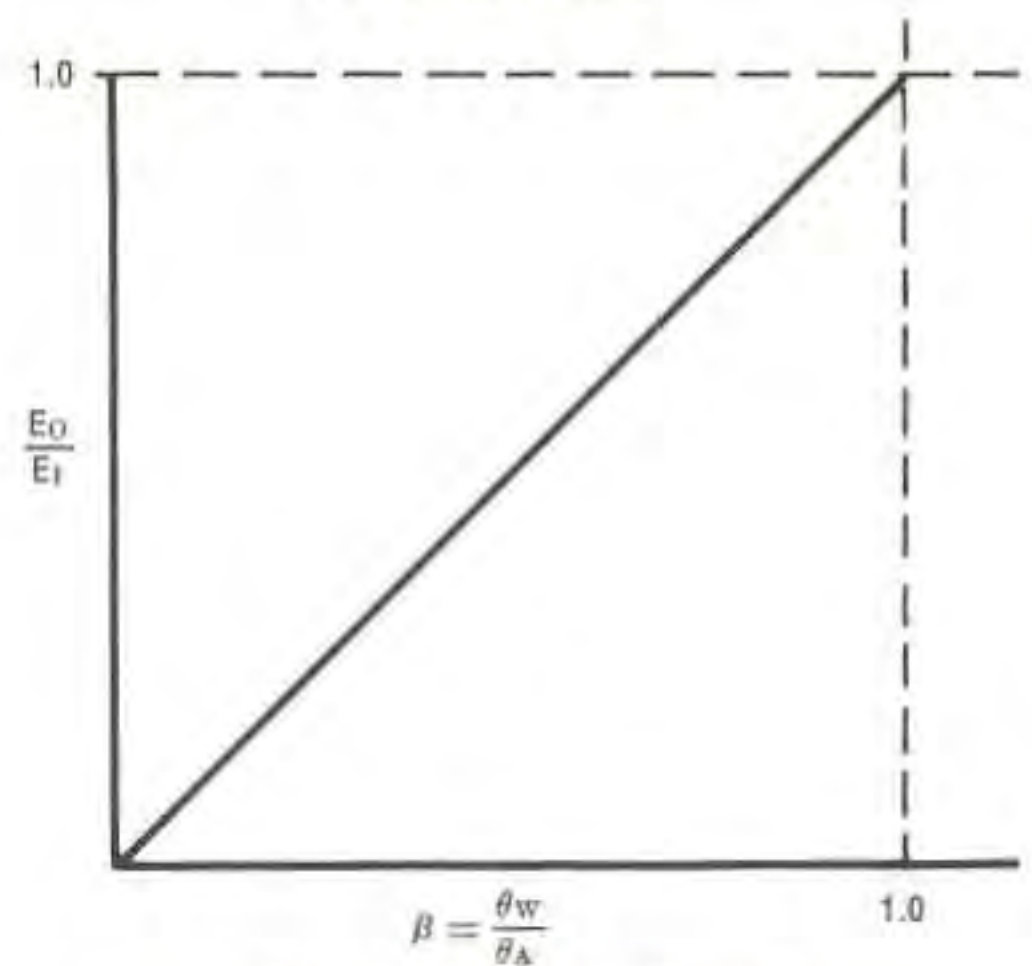
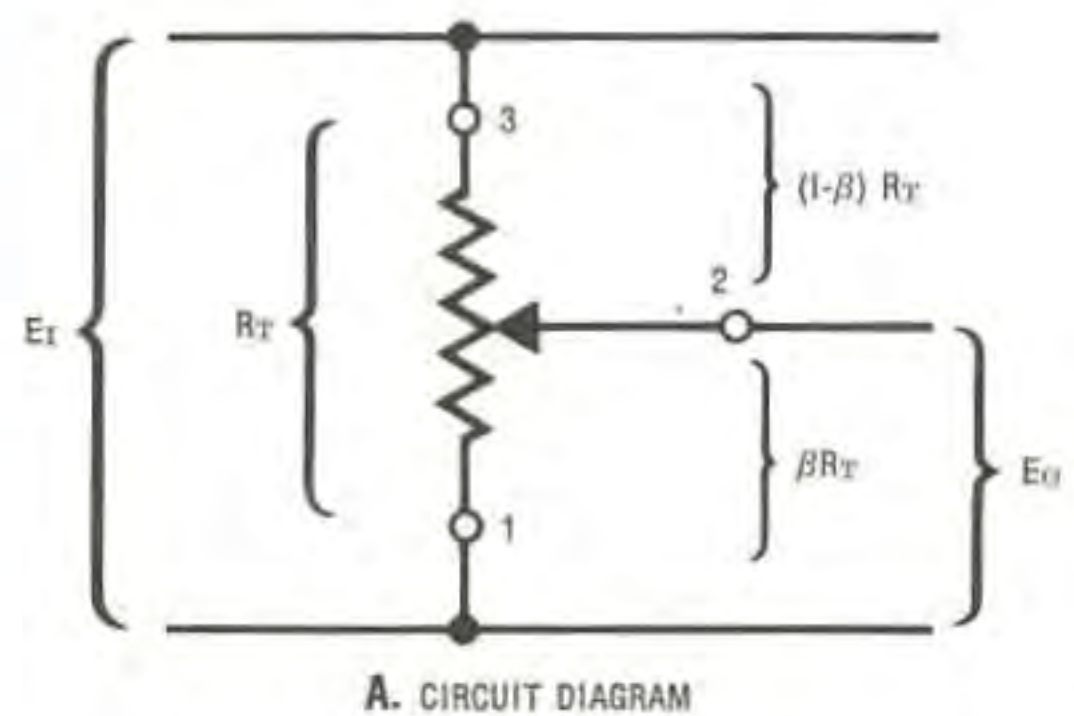

Fig. 3-1 The basic variable voltage divider



across the entire resistive element. The output voltage,  $E_o$ , is developed across the lower portion of the element, between the wiper terminal 2 and end terminal 1. The value of the resistance between terminals 2 and 1 will be  $\beta R_T$ , where  $\beta$  is the ratio of the particular wiper position to the total actual electrical travel or  $\beta = \frac{\theta_w}{\theta_A}$  and  $R_T$  is the mathematical symbol for total resistance. The resistance value for the remainder of the element will then be  $(1 - \beta)R_T$ .

The unloaded voltage output may be calculated:

$$E_o = \frac{\beta E_1 R_T}{\beta R_T + (1 - \beta)R_T} = \beta E_1$$

This relationship is represented by the linear output function shown in Fig. 3-1B.

**Adjustability.** The adjustability of output voltage ratio  $A_v$  is a direct indication of the accuracy with which any, arbitrarily selected, output voltage can be achieved. The  $A_v$  specification pertains explicitly to the voltage divider mode. For example, assume a potentiometer having an  $A_v = \pm 0.05\%$  is used in an application where  $E_1 = 100v$ . The circuit designer can expect to set any desired output voltage in the range 0–100v within .05v. Of course, intelligent design procedure requires the selection of a device based on the output voltage accuracy required.

In addition to indicating output accuracy, the  $A_v$  parameter is specified together with a maximum time-to-set duration of 20 seconds. This time limitation assures the potentiometer user that the specified accuracy can be obtained without an extended period of trial and error.

**Effects of TC.** The magnitude of a potentiometer's total resistance may change with variations in ambient temperature. The amount of the change will be proportional to the actual temperature coefficient TC of the particular resistive element. This presents no real difficulty in the simple variable voltage divider whose output voltage is a function of the *ratio* of two resistances. The entire length of the element may be assumed to have an essentially uniform temperature coefficient. If the temperature of the element varies uniformly, then the ratio of the divided portions will remain constant. This means that the output voltage will be unaffected by the TC of the potentiometer.

A slight variation in output voltage can be caused by temperature-change effects on the materials used to fabricate the device. This may result in minor mechanical movements. If the wiper moves relative to the element, then  $\beta$  will change. The same result occurs with a slight tem-

perature difference in two sections of the element. In most actual applications, the voltage input to the potentiometer will not be from a zero output impedance source. Also, the potentiometer output may be driving a load resistance. These conditions are additional sources for output voltage variation with temperature. Although the resulting effects will usually be negligible, they must be considered for critical applications involving significant ambient temperature variations.

**Effects of Linearity.** Since linearity is a direct indication of the degree to which the output function may deviate from the ideal straight line, the effects of linearity error may have to be considered when the potentiometer is used as a voltage divider.

If the wiper is very accurately positioned, *mechanically*, to some desired output ratio and an electronic measurement is made of the actual output voltage, the output voltage very probably will *not* be as predicted by the relationship:

$$E_o = \beta E_1$$

The error can be caused by any combination of the factors discussed in this chapter. The linearity specification is an indication of the amount of output error that can occur due to linearity factors alone.

When considering a linearity specification, note which of the four linearities is applicable. Refer to Chapter 2 for an explanation of linearity evaluation methods.

**Effects of Voltage Resolution.** Voltage resolution is the incremental change (steps) in output voltage that occurs as the wiper traverses a wirewound element. As illustrated in Chapter 2, the expanded output voltage function will exhibit a staircase form. The resulting discrete changes in output voltage level make it impossible to adjust the wiper to some values. This limitation is most pronounced in low resistance wirewound potentiometers due to the large diameter resistance element wire used in their construction.

**Power Rating.** The maximum power rating of most potentiometers assumes that the unit will be operated in the voltage divider mode. Thus a voltage will be applied to the input terminals with an insignificant load current through the wiper circuit.

A typical maximum power rating might be listed as 1.0w at an ambient temperature of 40°C and zero watts at 125°C. This two-point specification is illustrated by Fig. 3-2. The first part of the specification defines the location of point A. The second part of the specification, point B, indicates the operating temperature at which the maximum allowable power



dissipation falls to zero.

The permissible power dissipations for temperatures between 40°C and 125°C assume a linear derating curve defined by the straight line connecting the two points.

It is important to realize that it is the resulting *internal* temperature that is critical. It matters little to the potentiometer as to whether heat is caused by current passing through its element, high external ambient temperatures, or a combination of the two.

The manufacturer often views the two-point specification in the manner shown by Fig. 3-3 where the maximum allowable power dissipation is 1.0w for all temperatures 40°C and below. A circuit designer would do well to follow this approach unless he checks with the manufacturer. Extrapolation of the power rating plot to temperatures lower than that of the lowest specification, 40°C in the example, although logical and seemingly practical, is not wise. Other factors such as excessive element current may be involved.

Calculation of a power rating at some intermediate temperature between the two given in the specification is quite easy. First, determine the derating factor,  $p$ :

$$p = \frac{\Delta P}{\Delta T} = \frac{P_A - P_B}{T_A - T_B}$$

where  $P_A$  and  $P_B$  represent the allowable power dissipations at the two temperatures  $T_A$  and  $T_B$  respectively. For the specific example of Fig. 3-3:

$$p = \frac{1 - 0}{40 - 125} = -0.0118 \text{ watt/}^\circ\text{C}$$

Thus, for each degree C of rise in the ambient temperature, the power rating is decreased by .0118w. The power rating for any temperature within the two temperature extremes,  $T_A$  and  $T_B$ , may now be calculated:

$$P_D = P_A + p(T_D - T_A)$$

where  $P_D$  is the allowable power rating at temperature  $T_D$ .

Other factors may affect the realistic allowable power dissipation. A full power rating specification should describe the mounting conditions and whether the ambient is still air or forced convection. Generally it is safe to assume that the published rating applies to the standard mounting means for the given potentiometer in still air.

If the unit is mounted in a manner substantially different than the one for which it was designed, consideration should be given to the comparative thermal conductivities. Say that a bushing mounted unit which is normally

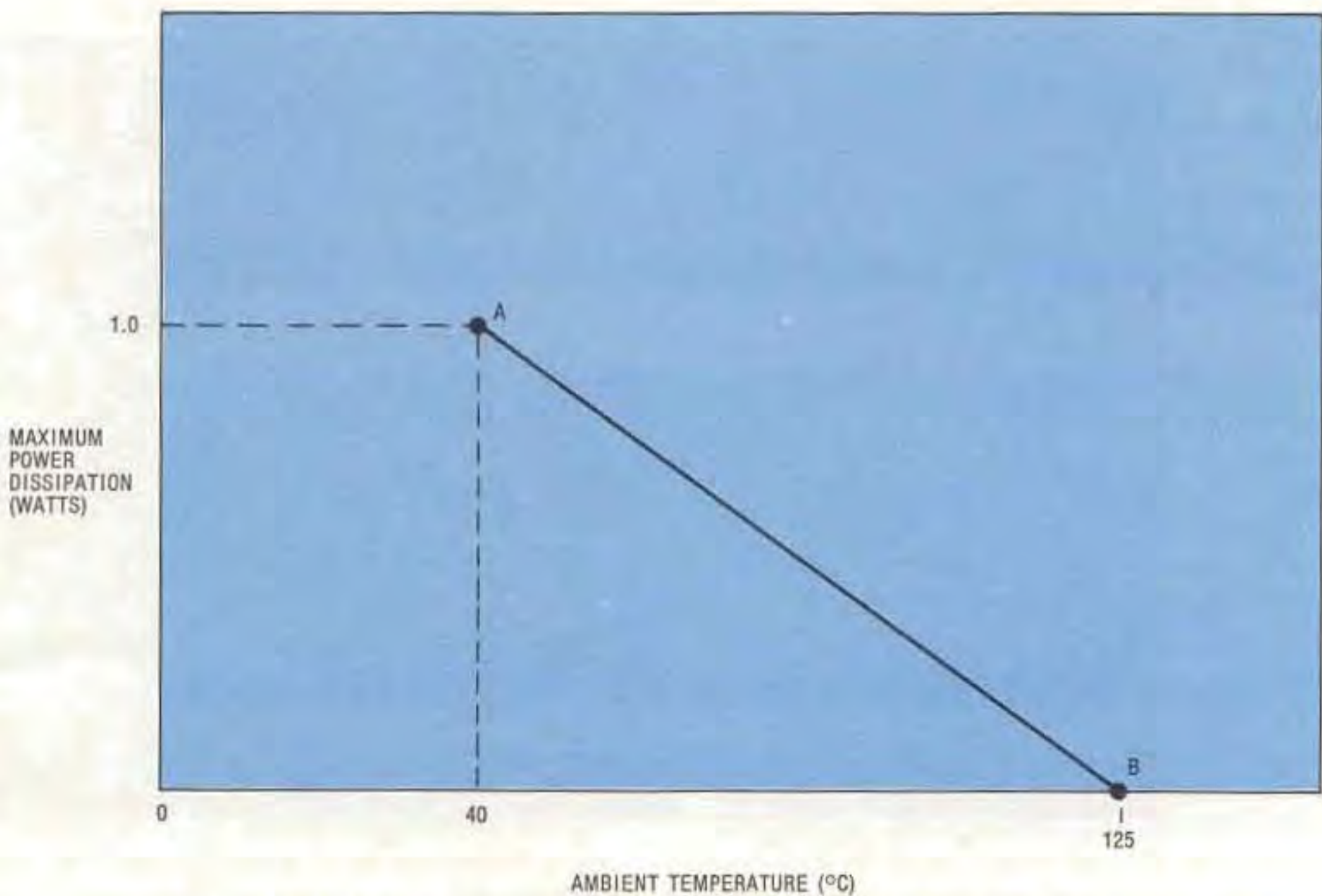

Fig. 3-2 A two-point power rating specification assumes linear operating



mounted to a metal panel will be mounted to a printed circuit board. The thermal conductivity of the epoxy-glass circuit board is much lower than metal, and it may be necessary to reduce the maximum power rating to assure reliable operation.

Be cautious when placing a potentiometer adjacent to a heat producing device such as a power transistor, vacuum tube, power transformer, power resistor, or even another potentiometer. Frequently several adjustment potentiometers may be mounted together with little space between them. With precision potentiometers or controls, more than one unit may be stacked on a common shaft for panel mounting. Derating the allowable power dissipation of the potentiometer may be wise.

**Loading Effects.** When a load resistance  $R_L$  is present in the output circuit of a variable voltage divider, shown in Fig. 3-4A, the output voltage can no longer be represented by the simple relation  $\beta E_T$ . To examine the affect of a load resistance, consider the potentiometer's Thévenin equivalent circuit as shown in Fig. 3-4B. The unloaded open-circuit voltage  $E'$ , which is equal to  $E_0$  in Fig. 3-1, must be divided between the terminal resistance  $R'$  and the load resistance  $R_L$ :

$$E'_0 = \frac{E'R_L}{R' + R_L} = \frac{E'R_L}{R_L + (\beta - \beta^2)R_T}$$

The fractional error in the output voltage, as compared with the unloaded ideal value, may be expressed as:

$$\delta = \frac{E'_0 - E'}{E'} = \frac{E'_0}{E'} - 1 \quad (E' = E_0)$$

Inserting the value for the output voltage as given above and simplifying:

$$\delta = \frac{-(\beta - \beta^2)}{\frac{R_L}{R_T} + (\beta - \beta^2)}$$

The value of  $\beta$  which yields maximum error may be found by setting the partial derivative of the above expression to zero. That is:

$$\frac{\partial \delta}{\partial \beta} = \frac{-\frac{R_L}{R_T}(1 - 2\beta)}{\left[\frac{R_L}{R_T} + (\beta - \beta^2)\right]^2} = 0$$

The only practical solution to this equation is:

$$1 - 2\beta = 0$$

$$\beta = 0.5$$

Insert this value into the general expression for  $\delta$  to get the maximum error.

$$\delta_{max} = \frac{-(0.5 - 0.5^2)}{\frac{R_L}{R_T} + (0.5 - 0.5^2)} = -\frac{1}{1 + 4\frac{R_L}{R_T}}$$

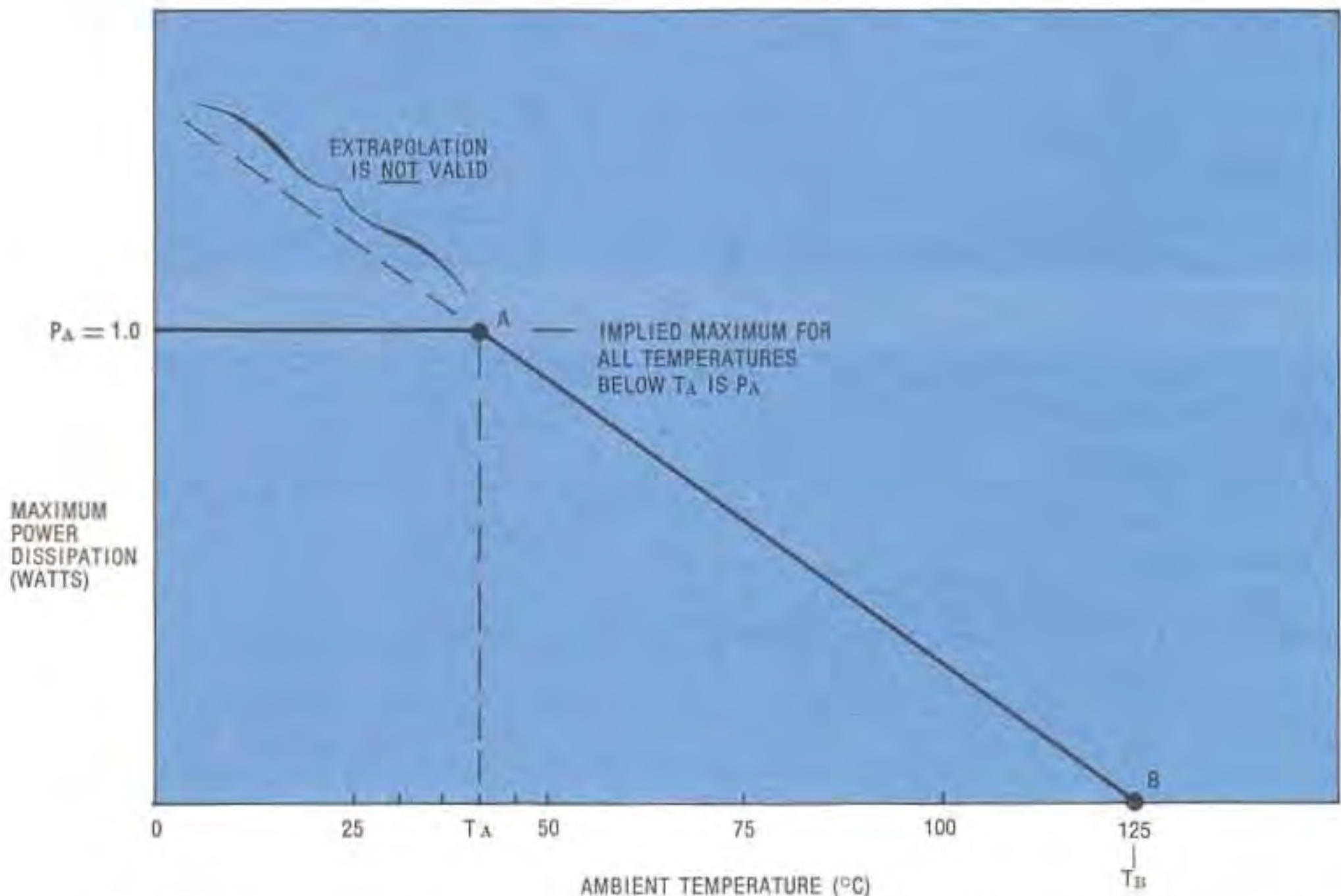
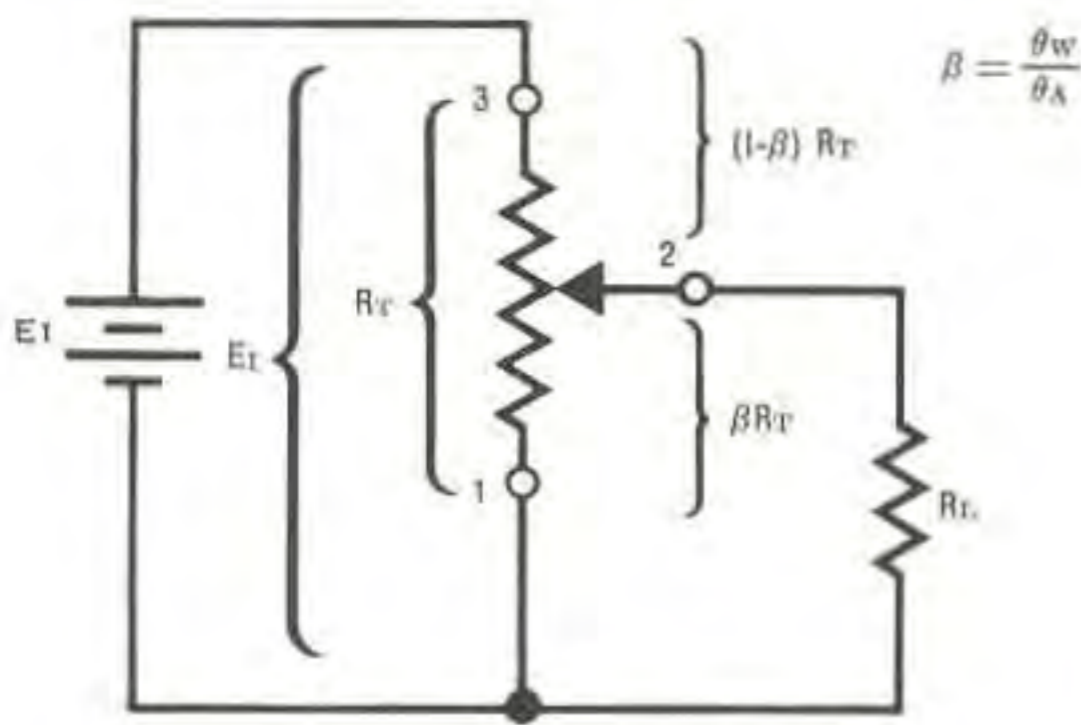
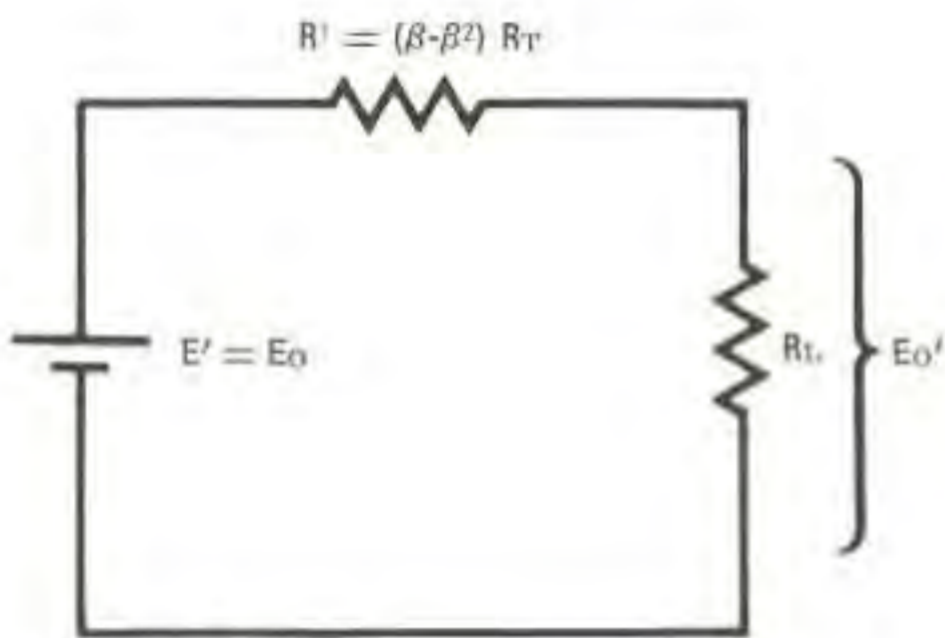

Fig. 3-3 A two point power rating specification implies a maximum power rating





A. LOADED VOLTAGE DIVIDER CIRCUIT



B. THEVENIN EQUIVALENT CIRCUIT

Fig. 3-4 Variable voltage divider circuit with significant load current

Fig. 3-5 shows the loading error as a function of relative wiper position for two cases. One where the load resistance is only twice the value of the total resistance and another where  $R_L$  is  $10 R_T$ . Fig. 3-6 is a tabulation of percentage loading errors over a range of  $R_L$  from  $0.1 R_T$  to  $100R_T$ . The solid line of Fig. 3-7 shows the maximum value of loading error (occurring at  $\beta=0.5$ ). The dashed line indicates the maximum loading error which would occur if the wiper positions were restricted to the end regions of the element.

The required minimum ratio of  $\frac{R_L}{R_T}$  can be

found from Figures 3-5, 3-6, and 3-7 for a given application having a known maximum allowable loading error. In many instances, a certain amount of compromise will be necessary since the large ratio required to assure a low loading error imposes a substantial power loss in the potentiometer element.

**Power Rating as Loaded Voltage Divider.** If potentiometers are used as variable voltage dividers supplying a significant output current, then power dissipation along the resistive element may be uneven. This is shown in Fig. 3-8.

The portion of resistive element from end terminal 3 to the wiper position conducts a current  $I_T$ . It is the sum of the load current  $I_L$  and the current through the remainder of the element  $I_E$ . The power dissipation per unit length of element is a function of the square of the current passing through it. Therefore, the length of the element supporting  $I_T$  will operate at a higher current density, amps per ohm, than that length carrying  $I_E$  alone and hence, will be required to support a higher temperature.

The curve of Fig. 3-9 shows how  $I_T$  varies as the wiper is moved from zero travel (zero output voltage) to maximum travel (maximum output voltage). For this example, an arbitrary load resistance equal to five times the potentiometer's total resistance was chosen.

Referring to Fig. 3-8, with the wiper at zero travel,  $I_L$  drops to zero and the only current through the potentiometer is due to the input voltage and resistive element. This state is analogous to an unloaded voltage divider application. As the wiper travel is increased, the output voltage and load current increase until a maximum value is reached:

$$I_{Lmax} = \frac{E_1}{R_L}$$

Note that the maximum power dissipation per unit length of element actually occurs just as the wiper reaches the end point at terminal 1. At the same time, the total power being dissipated in the portion of the element between terminals 3 and 2 approaches zero. The greatest *spot* temperature rise along the element will occur for a load current slightly below  $I_L$  maximum. This condition corresponds with a wiper position near the maximum output voltage setting. The exact values will depend upon the thermal conductivity of the adjacent element core and surrounding structure.

When considering power and load current requirements, the manufacturer's maximum wiper current rating must be respected under all possible conditions of wiper setting, ambient temperature, load resistance and output voltage. Remember, it is power dissipation concentration that can produce a localized elevated temperature that is detrimental to the potentiometer's life. To determine the maximum power rating and maximum wiper current rating, consult the published data sheet or the manufacturer.



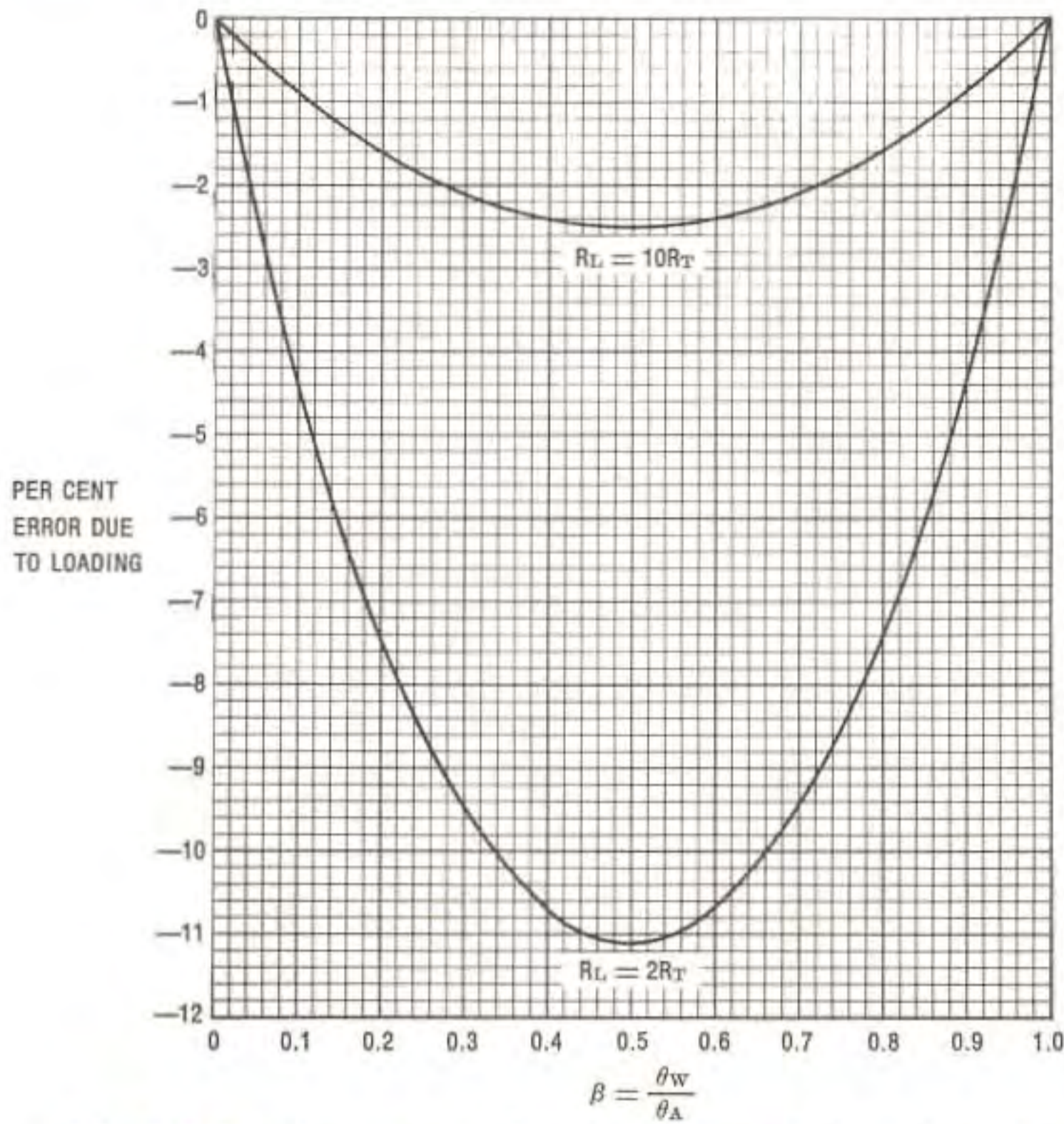

Fig. 3-5 Loading error is a function of the relative values of  $R_L$  and  $R_T$

PERCENT OUTPUT VOLTAGE ERROR									
$\frac{R_L}{R_T} \downarrow \beta \rightarrow$	0.1	0.2	0.3	0.4	0.5	0.6	0.7	0.8	0.9
0.10	-47.37	-61.54	-67.74	-70.59	-71.43	-70.59	-67.74	-61.54	-47.37
0.15	-37.50	-51.61	-58.33	-61.54	-62.50	-61.54	-58.33	-51.61	-37.50
0.22	-29.03	-42.11	-48.84	-52.17	-53.19	-52.17	-48.84	-42.11	-29.03
0.32	-21.95	-33.33	-39.62	-42.86	-43.86	-42.86	-39.62	-33.33	-21.95
0.46	-16.36	-25.81	-31.34	-34.29	-35.21	-34.29	-31.34	-25.81	-16.36
0.68	-11.69	-19.05	-23.60	-26.09	-26.88	-26.09	-23.60	-19.05	-11.69
1.00	-8.26	-13.79	-17.36	-19.35	-20.00	-19.35	-17.36	-13.79	-8.26
1.50	-5.66	-9.64	-12.28	-13.79	-14.29	-13.79	-12.28	-9.64	-5.66
2.20	-3.93	-6.78	-8.71	-9.84	-10.20	-9.84	-8.71	-6.78	-3.93
3.20	-2.74	-4.76	-6.16	-6.98	-7.25	-6.98	-6.16	-4.76	-2.74
4.60	-1.92	-3.36	-4.37	-4.96	-5.15	-4.96	-4.37	-3.36	-1.92
6.80	-1.31	-2.30	-3.00	-3.41	-3.55	-3.41	-3.00	-2.30	-1.31
10.00	-0.89	-1.57	-2.06	-2.34	-2.44	-2.34	-2.06	-1.57	-0.89
15.00	-0.60	-1.06	-1.38	-1.57	-1.64	-1.57	-1.38	-1.06	-0.60
22.00	-0.41	-0.72	-0.95	-1.08	-1.12	-1.08	-0.95	-0.72	-0.41
32.00	-0.28	-0.50	-0.65	-0.74	-0.78	-0.74	-0.65	-0.50	-0.28
46.00	-0.20	-0.35	-0.45	-0.52	-0.54	-0.52	-0.45	-0.35	-0.20
68.00	-0.13	-0.23	-0.31	-0.35	-0.37	-0.35	-0.31	-0.23	-0.13
100.00	-0.09	-0.16	-0.21	-0.24	-0.25	-0.24	-0.21	-0.16	-0.09

Fig. 3-6 Loading errors for a variable voltage divider



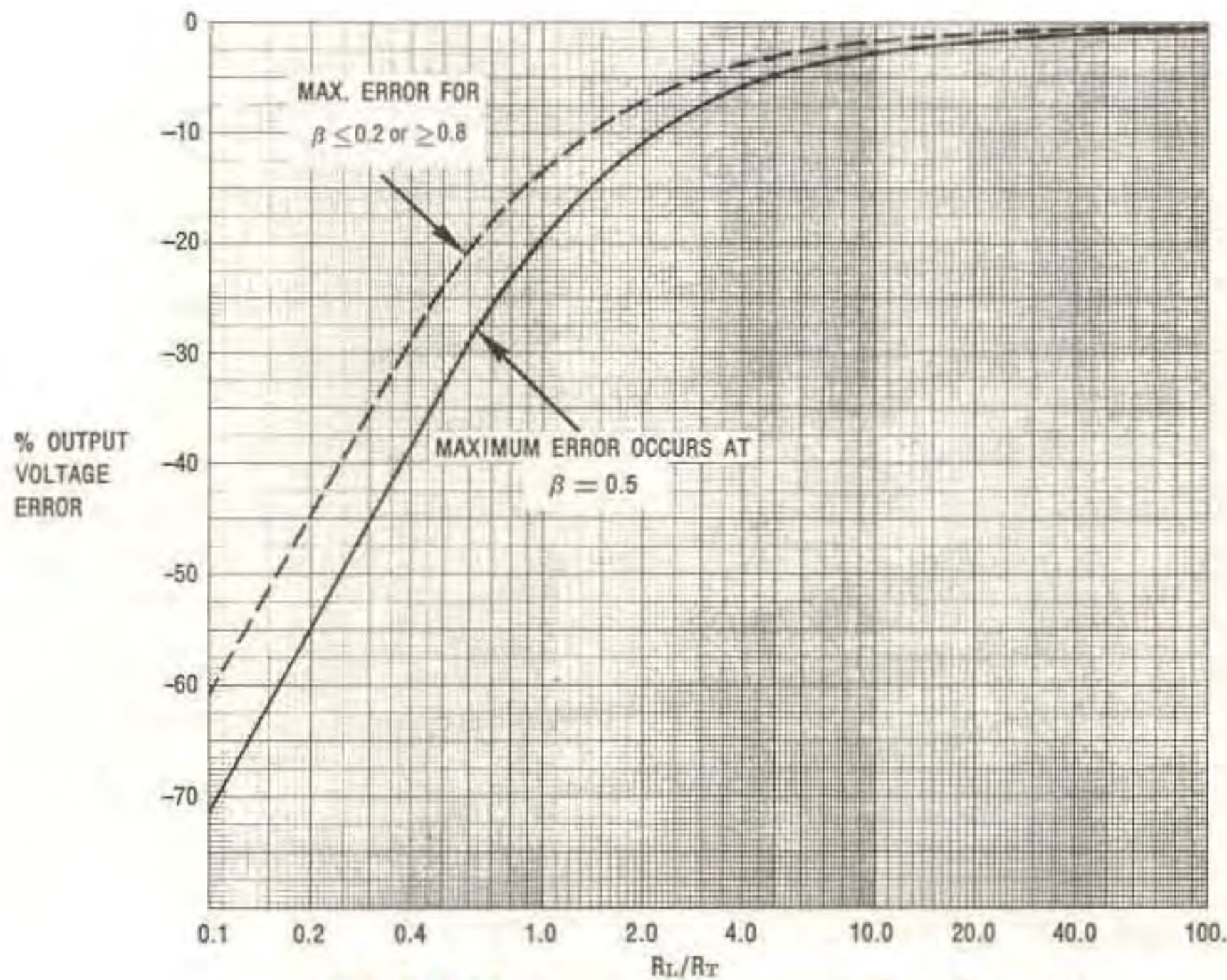

Fig. 3-7 Maximum uncompensated loading error

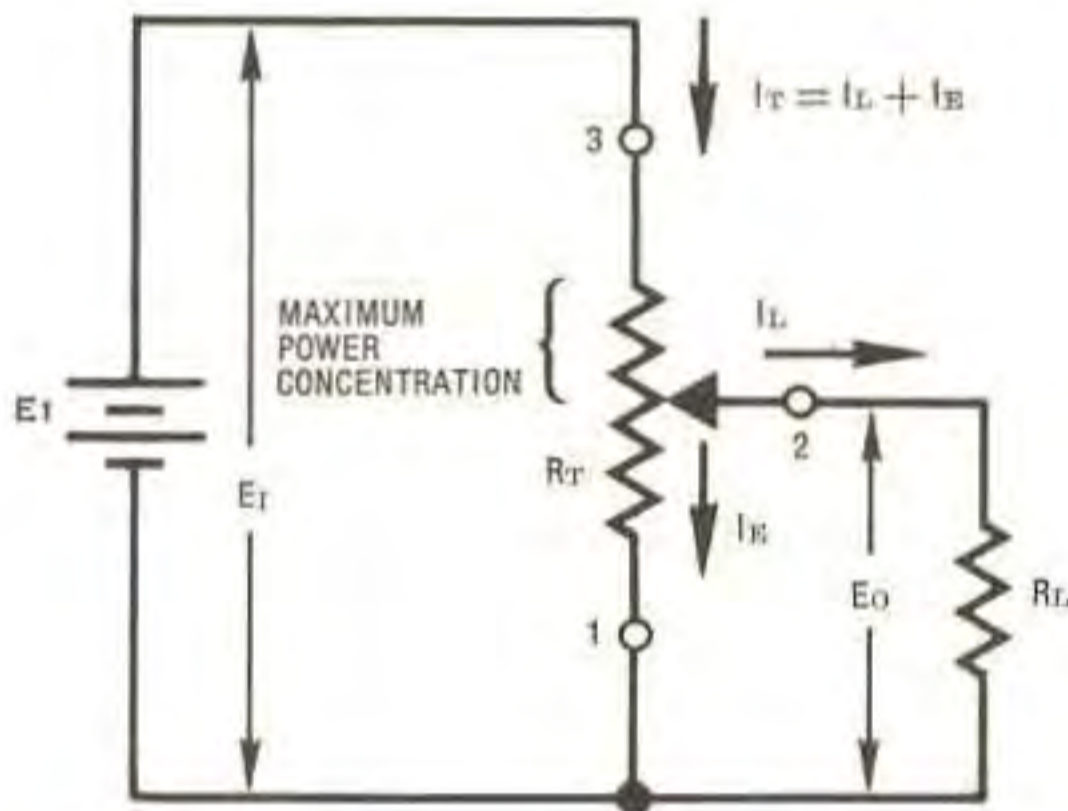

Fig. 3-8 Power dissipation is not distributed uniformly in a loaded voltage divider application

**Compensating Loading Errors.** The addition of a single compensating resistor,  $R_1$  in Fig. 3-10A, will provide a limited reduction in loading error. Using the equivalent circuit given in Fig. 3-10B, the output voltage and the fractional error can be calculated. The output voltage is:

$$E'_o = E' + \left[ \frac{E'' - E'}{R'' + R'} \right] R' = E' + \left[ \frac{\frac{E'}{\beta} \left( \frac{1}{1 + \eta} \right) - E'}{(\beta - \beta^2)R_T + \left( \frac{\eta}{1 + \eta} \right) R_L} \right] (\beta - \beta^2)R_T$$

The error is:

$$\delta = \frac{E_o - E'_o}{E'_o} = \left[ \frac{\frac{1}{\beta(1 + \eta)} - 1}{(\beta - \beta^2) + \left( \frac{\eta}{1 + \eta} \right) \frac{R_T}{R_L}} \right] (\beta - \beta^2) = \frac{\frac{1}{\eta} (1 - \beta^2) - (\beta - \beta^2)}{\left( \frac{1}{\eta} + 1 \right) (\beta - \beta^2) + \frac{R_L}{R_T}}$$



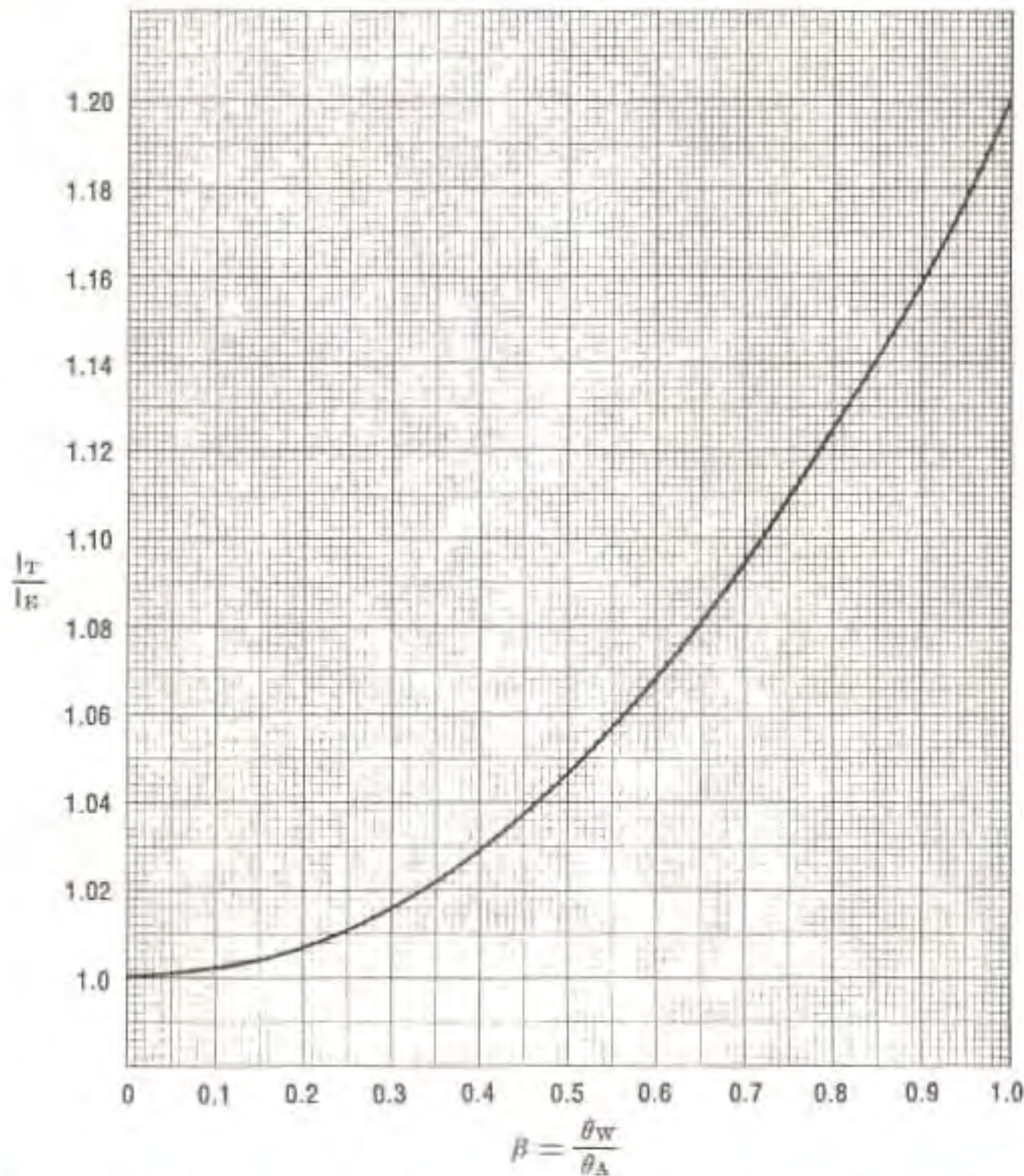

Fig. 3-9 Normalized total input current for the circuit of Fig. 3-8 with  $R_L = 5R_T$

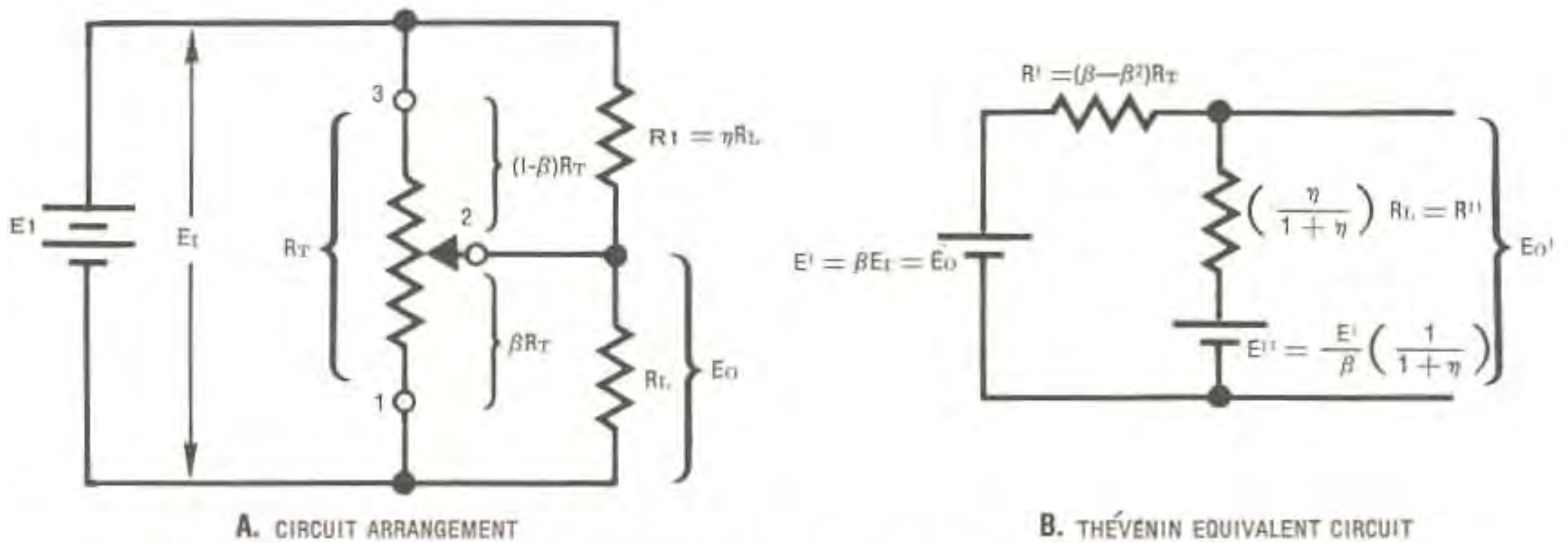

Fig. 3-10 A limited degree of compensation for loading effects is possible by use of a single additional resistor

where all terms except  $\eta$ , the ratio of the compensation resistor to the load resistor, have been defined previously. The equivalent circuit of Fig. 3-10B is determined by applying Thévenin's Theorem twice to the circuit of Fig. 3-10A. First, with  $R_1$  and  $R_L$  disconnected and then with only the potentiometer disconnected.

Look back at the curves of Fig. 3-5. Notice that the error is greatest when the wiper is at the

center position of the potentiometer's resistive element. Intuitively, it might be supposed that if the center region could be forced to zero error, by the proper selection of a compensation resistor, the optimum design would result. Using the formula for compensated output voltage error given above, insert the value  $\beta = 0.5$ , which corresponds to the center of travel. Then determine the required value for  $\eta$ , to make the error



zero:

$$\delta = \frac{\left(\frac{1}{\eta}\right)(1-0.5^2) - (0.5-0.5^2)}{\left(\frac{1}{\eta}+1\right)(0.5-0.5^2) + \frac{R_L}{R_T}}$$

Set the numerator equal to zero:

$$\frac{1}{\eta}(.25) - .25 = 0$$

$$\eta = 1$$

This  $R_1$  to  $R_L$  ratio is simple to achieve, but look at the error values for other possible positions of the wiper. Fig. 3-11 presents a plot of the errors resulting from varying degrees of compensation for a specific example where  $R_1 = 10R_T$ . The bottom curve describes the error resulting from no compensation. It indicates a maximum error magnitude of about 2.5%.

The top curve covers the case where the compensating resistor is made equal to the load resistor. Notice that zero loading error is achieved when  $\beta = 0.5$  and, for all values of  $\beta$  from 0.33 to 1.0, the error magnitude is lower than for the uncompensated condition. However, for the lower one third of the wiper travel, the error rises sharply and exceeds the worst-case uncompensated error for all values of  $\beta$ . This indicates that the  $R_1 = R_L$  degree of compensation is wise only where the active wiper travel will be restricted to the upper portion of the element. Fig. 3-11 also shows other curves for lesser degrees of compensation. Fig. 3-12 is a tabulation of compensated loading errors for several possible degrees of compensation for the condition of  $R_L = 10R_T$ .

Fig. 3-13 lists the loading errors for moderate ( $\eta = 3$ ) compensation at varying loading ratios. Compare this table with Fig. 3-6. Notice that a substantial reduction in loading error has occurred for a major portion of the wiper travel. Always consider the increased error in the lower regions of wiper travel before employing this method of compensation. In some systems, the errors due to loading or overcompensation may actually be useful as compensation for other possible errors.

**Varying the Adjustment Range.** The output voltage for the basic variable voltage divider, shown in Fig. 3-1, may be adjusted for any value within the  $A_V$  specification between zero and the full input voltage. Many applications do not require this much variation and, in fact, need to have definite limits applied to the adjustment range.

Fixed resistors, placed in series at either one or both ends of the potentiometer's element, as

shown in Fig. 3-14, can be used to restrict the minimum and maximum output voltage. The overall effect is equivalent to a potentiometer with a limited wiper travel.

The element of the equivalent potentiometer consists of the two end resistors  $R_1$  and  $R_2$  together with the potentiometer's resistive element. Consider the equivalent parameters of this composite.

The equivalent total resistance is:

$$R'_T = R_1 + R_2 + R_T$$

The minimum equivalent travel position is:

$$\beta'_{\min} = \frac{R_2}{R'_T}$$

The maximum equivalent travel position is:

$$\beta'_{\max} = \frac{R_T + R_2}{R'_T}$$

The adjustment range is:

$$\Delta\beta' = \beta'_{\max} - \beta'_{\min} = \frac{R_T + R_2}{R'_T} - \frac{R_2}{R'_T} = \frac{R_T}{R'_T}$$

The formulas given for loading error and maximum loading error are applicable to the composite potentiometer when  $R'_T$  is substituted for  $R_T$  and  $\beta'$  is substituted for  $\beta$ . Since the equivalent relative travel is restricted to the minimum and maximum limits given above, it may be that the maximum theoretical loading error, occurring at  $\beta = 0.5$ , may not occur within the adjustment range.

The following text is a step by step generalized design example. The values for  $E_T$ ,  $E_{O\min}$ ,  $E_{O\max}$ , and  $R_L$  are all known. Either the table of Fig. 3-6 or the curve of Fig. 3-7 can be used to determine the minimum  $\frac{R_L}{R_T}$  ratio that will restrict the maximum loading error to an acceptable limit. For example, if the loading error must be held to less than 2.5%,  $\frac{R_L}{R_T}$  must be 10 or more.

A tentative value for  $R'_T$  can now be computed:

$$R'_T = \frac{R_L}{\left(\frac{R_L}{R_T}\right)_{\min}}$$

The total resistance of the potentiometer is:

$$R_T = R'_T \cdot \Delta\beta' = R'_T \left[ \frac{E_{O\max} - E_{O\min}}{E_T} \right]$$

The value of total resistance obtained from the above formula is unlikely to be a standard value. Choose an available TR value as close as



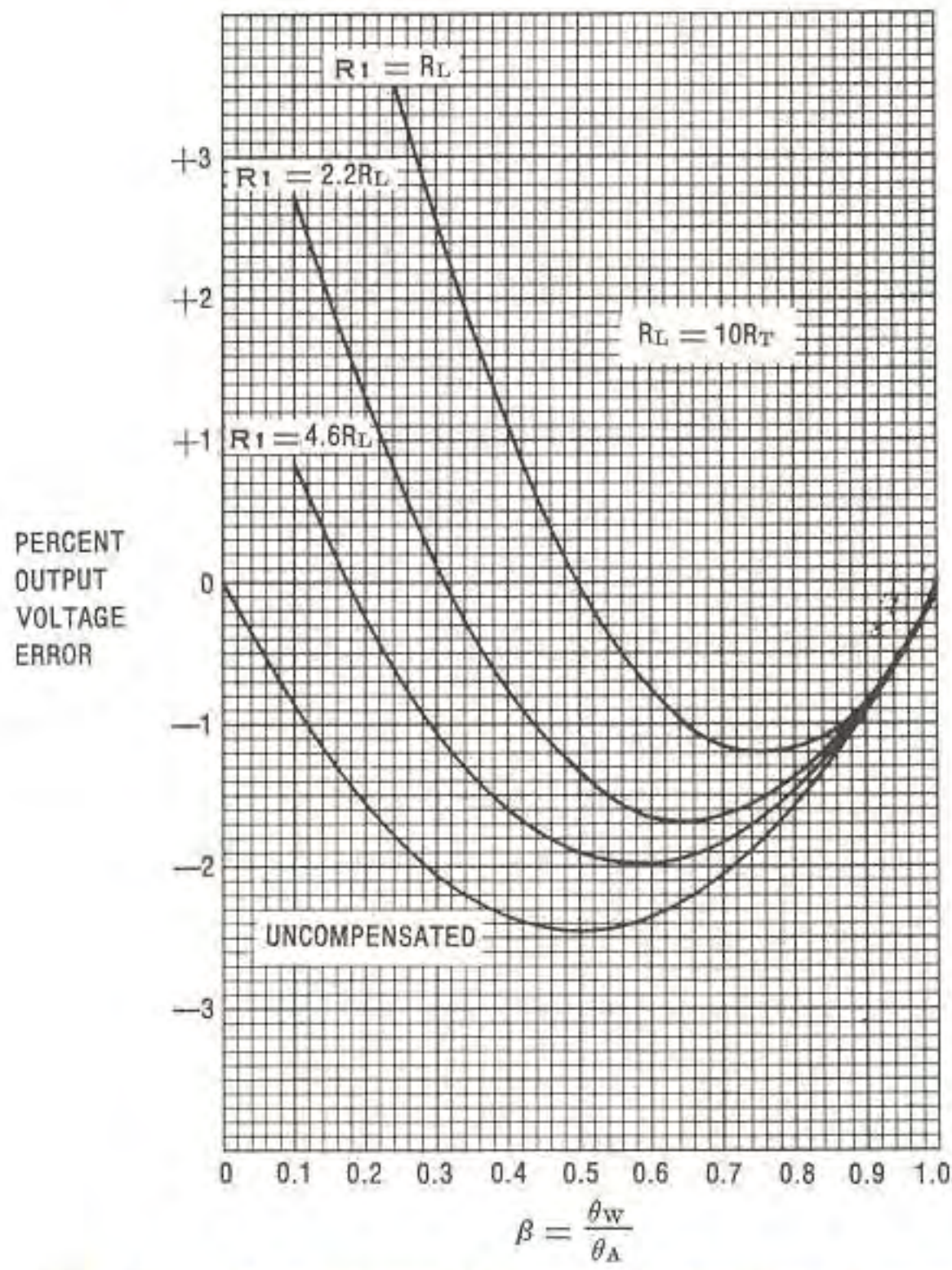

Fig. 3-11 Output error for several degrees of compensation

PERCENT OUTPUT VOLTAGE ERROR									
$\frac{R_1}{R_L} \downarrow \beta \rightarrow$	0.1	0.2	0.3	0.4	0.5	0.6	0.7	0.8	0.9
NO $R_1$ COMP.	-0.89	-1.57	-2.06	-2.34	-2.44	-2.34	-2.06	-1.57	-0.89
10.	-0.09	-0.94	-1.57	-1.99	-2.19	-2.18	-1.96	-1.53	-0.88
6.8	0.29	-0.65	-1.35	-1.82	-2.07	-2.11	-1.92	-1.51	-0.88
4.6	0.85	-0.20	-1.01	-1.57	-1.90	-1.99	-1.86	-1.48	-0.87
3.2	1.61	0.39	-0.55	-1.24	-1.66	-1.84	-1.77	-1.44	-0.86
2.2	2.75	1.28	0.12	-0.74	-1.32	-1.62	-1.64	-1.39	-0.84
1.5	4.43	2.60	1.13	0.00	-0.80	-1.28	-1.45	-1.30	-0.82
1.0	7.07	4.65	2.69	1.15	0.00	-0.76	-1.15	-1.16	-0.79
0.68	10.77	7.51	4.85	2.73	1.11	-0.04	-0.74	-0.97	-0.74
0.46	16.24	11.72	8.02	5.04	2.72	1.00	-0.13	-0.70	-0.66
0.32	23.54	17.26	12.16	8.05	4.82	2.37	0.66	-0.33	-0.57
0.22	34.21	25.25	18.07	12.32	7.78	4.30	1.78	0.20	-0.42
0.15	49.67	36.58	26.33	18.24	11.89	6.98	3.36	0.95	-0.22
0.10	72.88	53.06	38.10	26.58	17.65	10.76	5.61	2.04	0.09

Fig. 3-12 Compensated loading error where  $R_L = 10R_T$



PERCENT OUTPUT VOLTAGE ERROR									
$\frac{R_L}{R_T} \downarrow \beta \rightarrow$	0.1	0.2	0.3	0.4	0.5	0.6	0.7	0.8	0.9
1.000	16.07	4.40	-3.65	-9.09	-12.50	-14.14	-14.06	-12.09	-7.74
1.500	11.11	3.11	-2.62	-6.59	-9.09	-10.26	-10.11	-8.56	-5.35
2.200	7.76	2.21	-1.88	-4.76	-6.58	-7.41	-7.26	-6.08	-3.74
3.200	5.42	1.56	-1.34	-3.41	-4.72	-5.30	-5.17	-4.30	-2.61
4.600	3.81	1.11	-0.96	-2.44	-3.38	-3.79	-3.69	-3.05	-1.84
6.800	2.60	0.76	-0.66	-1.69	-2.34	-2.62	-2.54	-2.09	-1.25
10.000	1.78	0.52	-0.45	-1.16	-1.61	-1.81	-1.75	-1.44	-0.86

Fig. 3-13 Compensated loading error where  $R_1 = 3R_L$

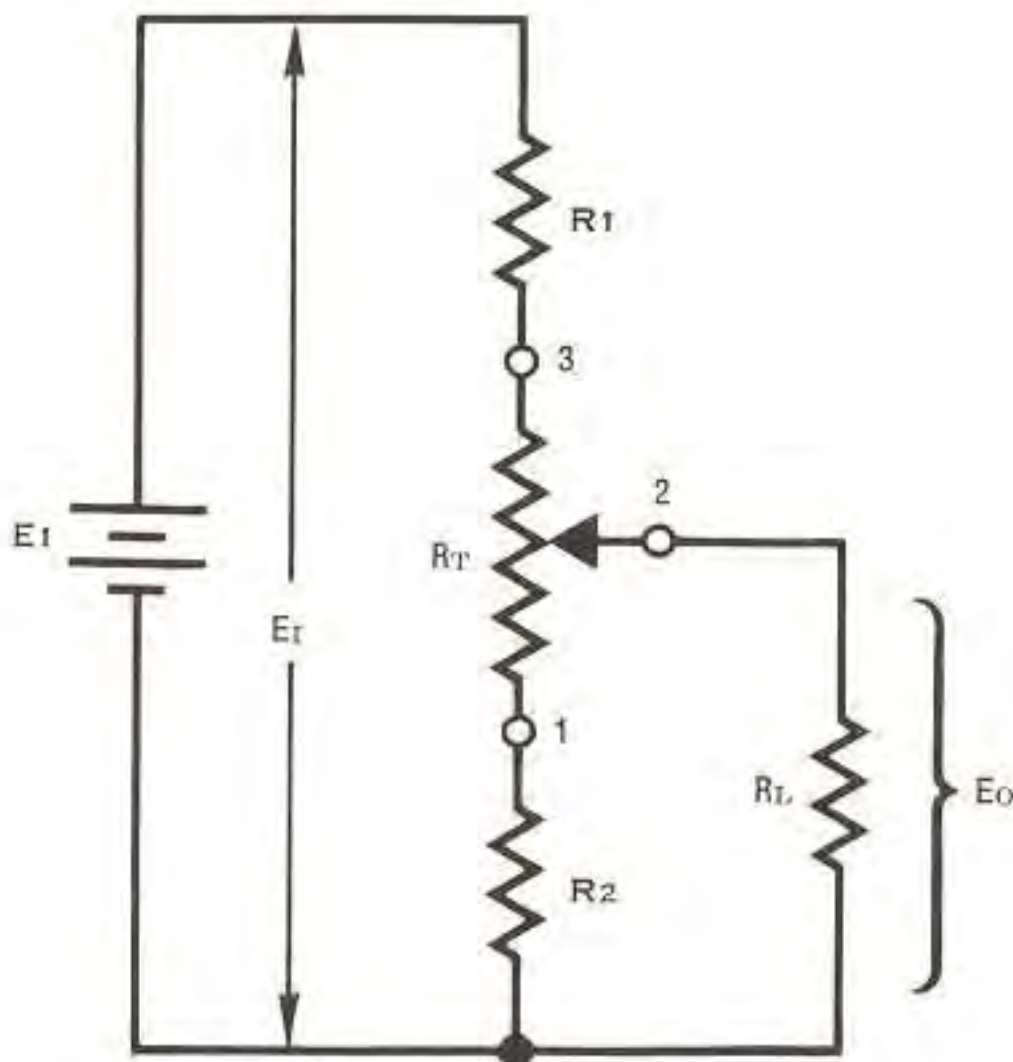

Fig. 3-14 Adjustment range is fixed by resistors placed in series with the potentiometer element

possible to, but not greater than, the calculated value. Now, recompute the value of  $R'_T$ :

$$R'_T = \frac{R_T}{\Delta\beta'} = R_T \left[ \frac{E_I}{E_{Omax} - E_{Omin}} \right]$$

The end resistors may then be computed from:

$$R_1 = \left[ 1 - \frac{E_{Omax}}{E_I} \right] R'_T$$

$$R_2 = \beta'_{min} R'_T = \left[ \frac{E_{Omin}}{E_I} \right] R'_T$$

As a specific example, assume that the following requirements are given:

$$E_I = 10v \quad E_{Omin} = 2v \quad E_{Omax} = 9v$$

$$R_L = 10k \quad \text{max. loading error} = 2.5\%$$

Fig. 3-6 indicates that  $\frac{R_L}{R_T}$  must be 10 or more for a maximum loading error of 2.5%. This gives an initial value for  $R'_T$  of  $10K/10 = 1K$ . Now, compute the value for  $R_T$ :

$$R_T = (1k) \left[ \frac{9-2}{10} \right] = 700 \text{ ohms}$$

Unfortunately, 700 ohms is not available as a standard value. The nearest ones are, say, 500 and 1000 ohms for the potentiometer type being considered. In order to keep the loading error within the given requirements, choose the lower TR, 500 ohms.

Now, recompute  $R'_T$ , using the actual value of TR:

$$R'_T = 500 \left[ \frac{10}{9-2} \right] = 714.3 \text{ ohms}$$

Then,

$$R_1 = \left( 1 - \frac{9}{10} \right) (714.3) = 71.4 \text{ ohms}$$

$$R_2 = \left( \frac{2}{10} \right) (714.3) = 142.9 \text{ ohms}$$



The resistors used for  $R_1$  and  $R_2$  should have a TC which matches that of the potentiometer element, if optimum temperature stability is to be achieved. Remember also that the resistance tolerance of the potentiometer will affect the actual range limits. In some applications, it may be wise to use trimming potentiometers for the end resistors to allow precise control of the limits.

The effective resolution of the equivalent potentiometer is improved by a factor equal to  $\frac{R_T'}{R_T}$ , since the actual resolution of the potentiometer used applies to the adjustment range only.

Load compensation, as described previously, can be applied to the limited adjustment range configuration of Fig. 3-14 using the equivalent composite parameters.

**Optimizing Resolution and Adjustability.** In many applications, the conformity of the output voltage function is of secondary importance as compared to the accuracy of adjustment over a limited range. A particular application might require an adjustable voltage through a range of only 10% of the total input voltage, most of the time. Occasionally, it may be necessary for the same potentiometer to provide a significantly greater adjustment range. If the basic variable voltage divider approach is used, the normal adjustment range will be a small portion of the potentiometer's actual travel. The full adjustment range will be used only on those occasions where extremes are required.

The output may be intentionally loaded as shown in Fig. 3-15 to alter the output in a way that yields a more desirable adjustment capability. Fig. 3-16 shows the results for three different degrees of this shaping. Note the curve for the condition where  $R_1$  and  $R_2$  are both

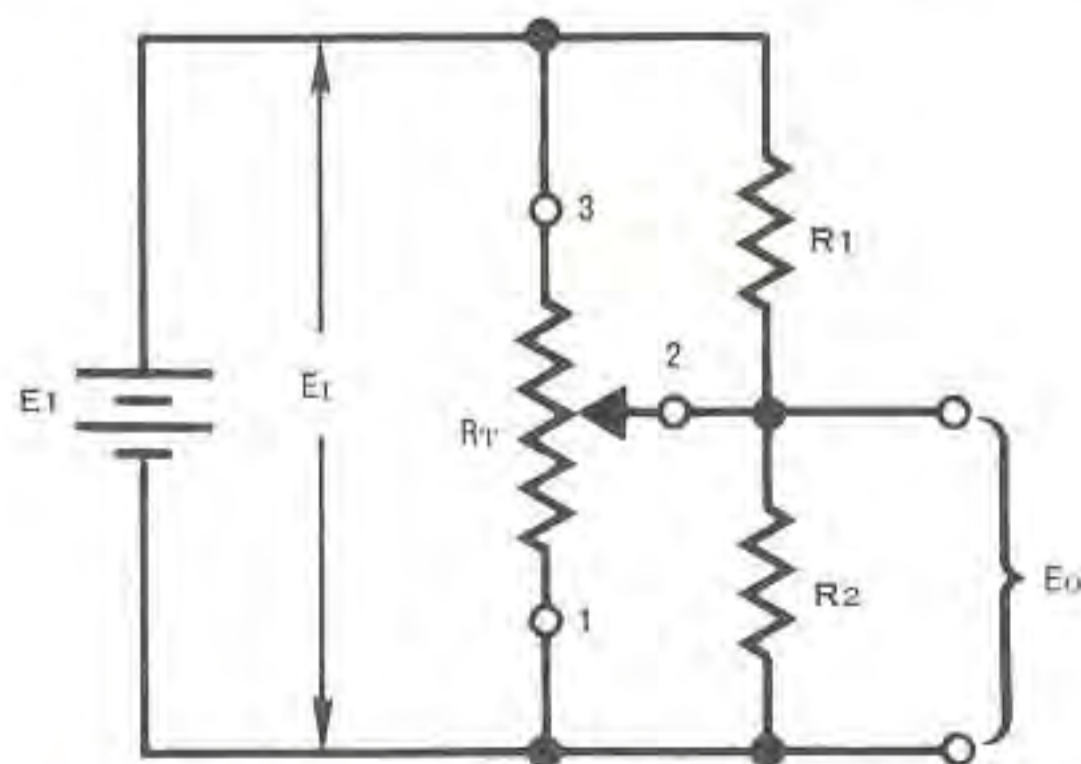

**Fig. 3-15** Effective resolution over a limited range can be improved by intentional loading

made equal to  $0.1R_T$ . A major portion of the potentiometer's total travel is required to vary the output voltage from  $0.4E_1$  to  $0.6E_1$ . Specifically, almost 70% ( $\beta = .16$  to  $.82$ ) of the wiper total travel is required to produce 20% ( $\frac{E_0}{E_1} = .4$  to  $.6$ ) change in output voltage. For most of this range, the output is relatively linear. If required, an output voltage covering the entire range of  $E_1$  is possible.

The result is resolution and adjustability are improved by a factor of nearly 6 in the center region. This is compared with the unloaded voltage divider whose output function is indicated by the straight line in Fig. 3-16. Note that the slope for the loaded case is less than the unloaded case in the range  $0.1E_1$  to  $0.9E_1$ . The magnitude of the slope increases rapidly outside this region.

Fig. 3-16 also includes the output function resulting from making  $R_1$  and  $R_2$  both equal to  $R_T$ . With these values, only a very slight improvement is obtained.

The values of  $R_1$  and  $R_2$  need not be equal except when the output voltage of major interest is around  $0.5E_1$ . Varying the ratio between the loading resistors will shift the region of improved resolution as shown by the two examples given in Fig. 3-17. Again, the straight line output function of the unloaded case is included for reference.

## VARIABLE CURRENT RHEOSTAT MODE

Many applications use the variable resistance between the wiper and one end terminal as a method of current adjustment. This two-terminal method of connection is frequently referred to as simply the *rheostat mode*. The term *variable resistance mode* is also in common usage. However, it is felt that this latter terminology is descriptive of the device's primary characteristic, variable resistance, rather than a particular application mode.

Fig. 3-18A illustrates the basic circuit arrangement. Fig. 3-18B shows three possible load current vs. wiper position curves. The total circuit resistance and applied voltage are equal in all three cases. Only the ratio of potentiometer TR to load resistance  $R_L$  has been varied. As the chosen TR becomes larger, compared to  $R_L$ , a greater range of load current variability is realized.

The choice of input and output terminals is arbitrary since the potentiometer, when applied as a current control, is a two-terminal bidirectional device. Of course, one of the selected terminals must be the movable contact terminal 2. If end terminal 1 is chosen as the second



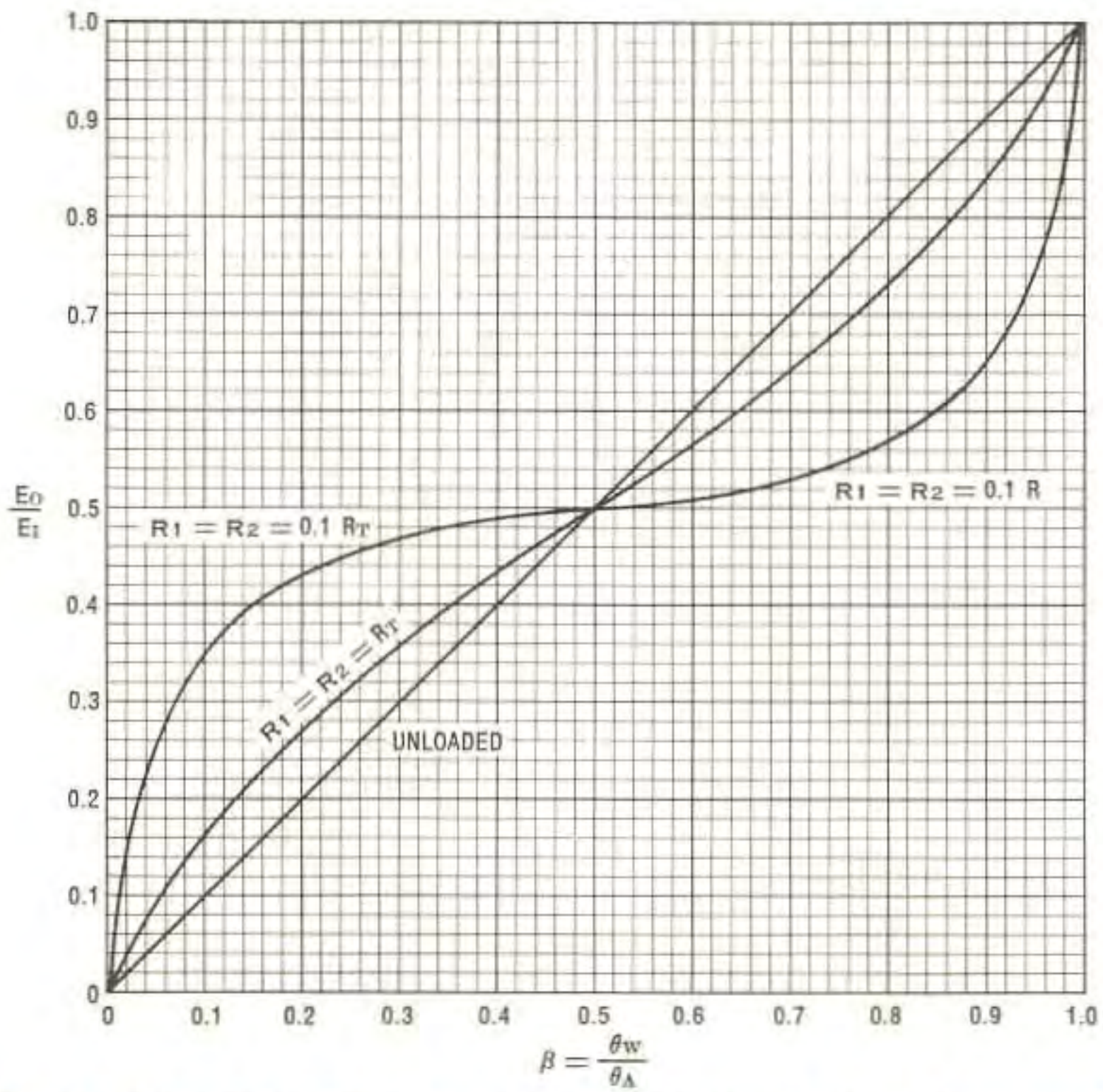

Fig. 3-16 Effective resolution in center of adjustment range is improved by loading

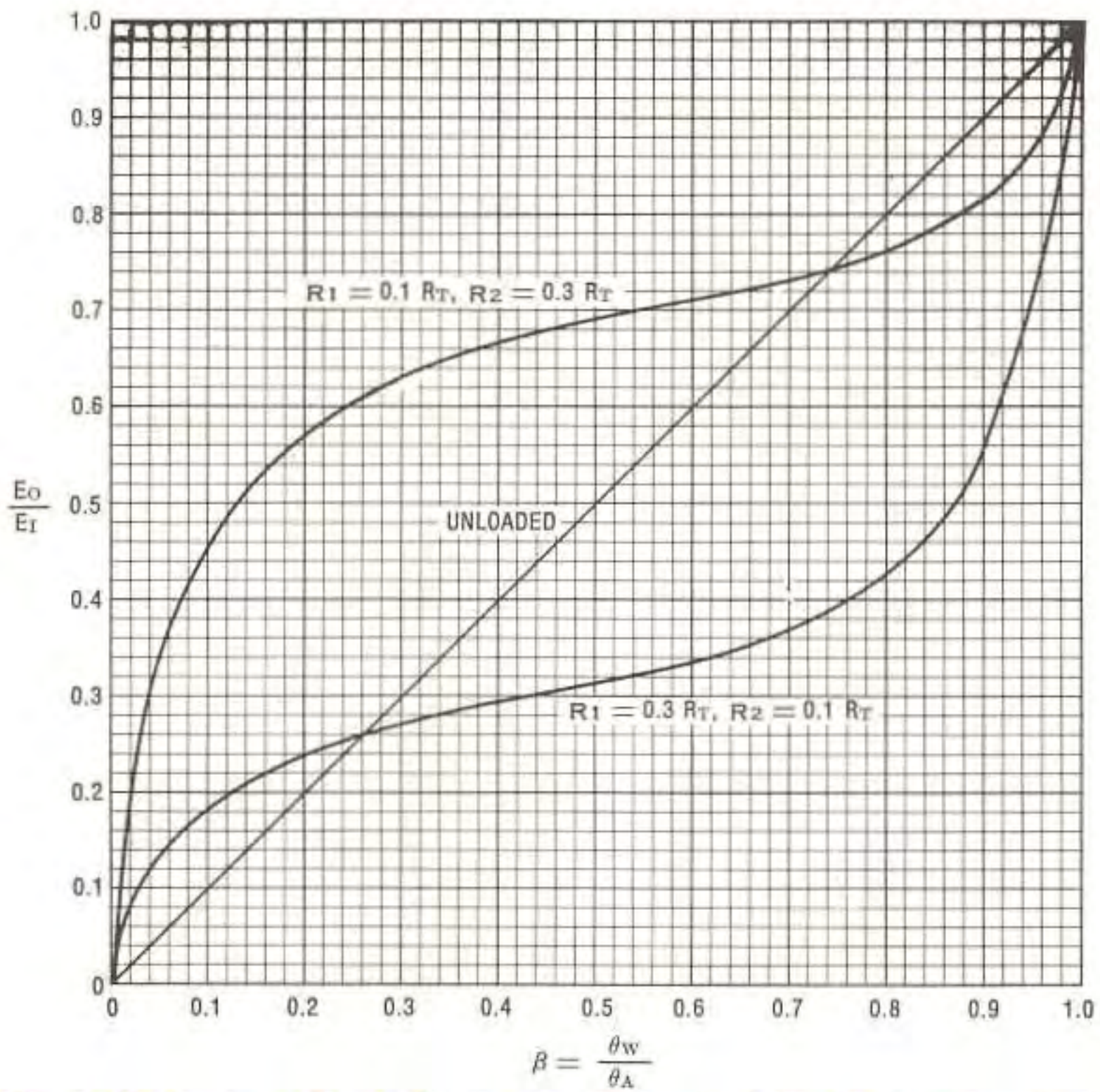

Fig. 3-17 Region of best effective resolution is shifted by varying the  $R_1/R_2$  ratio



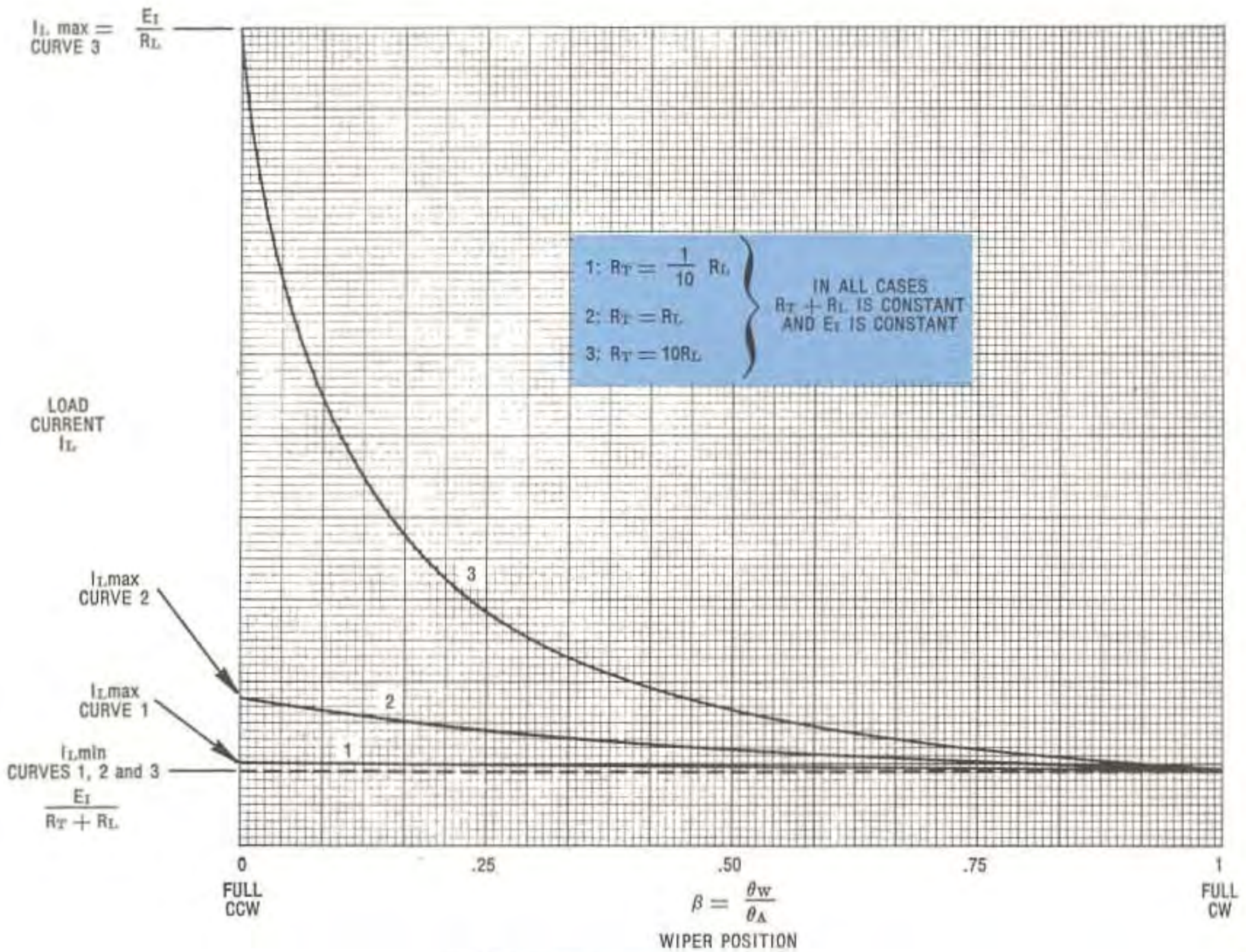
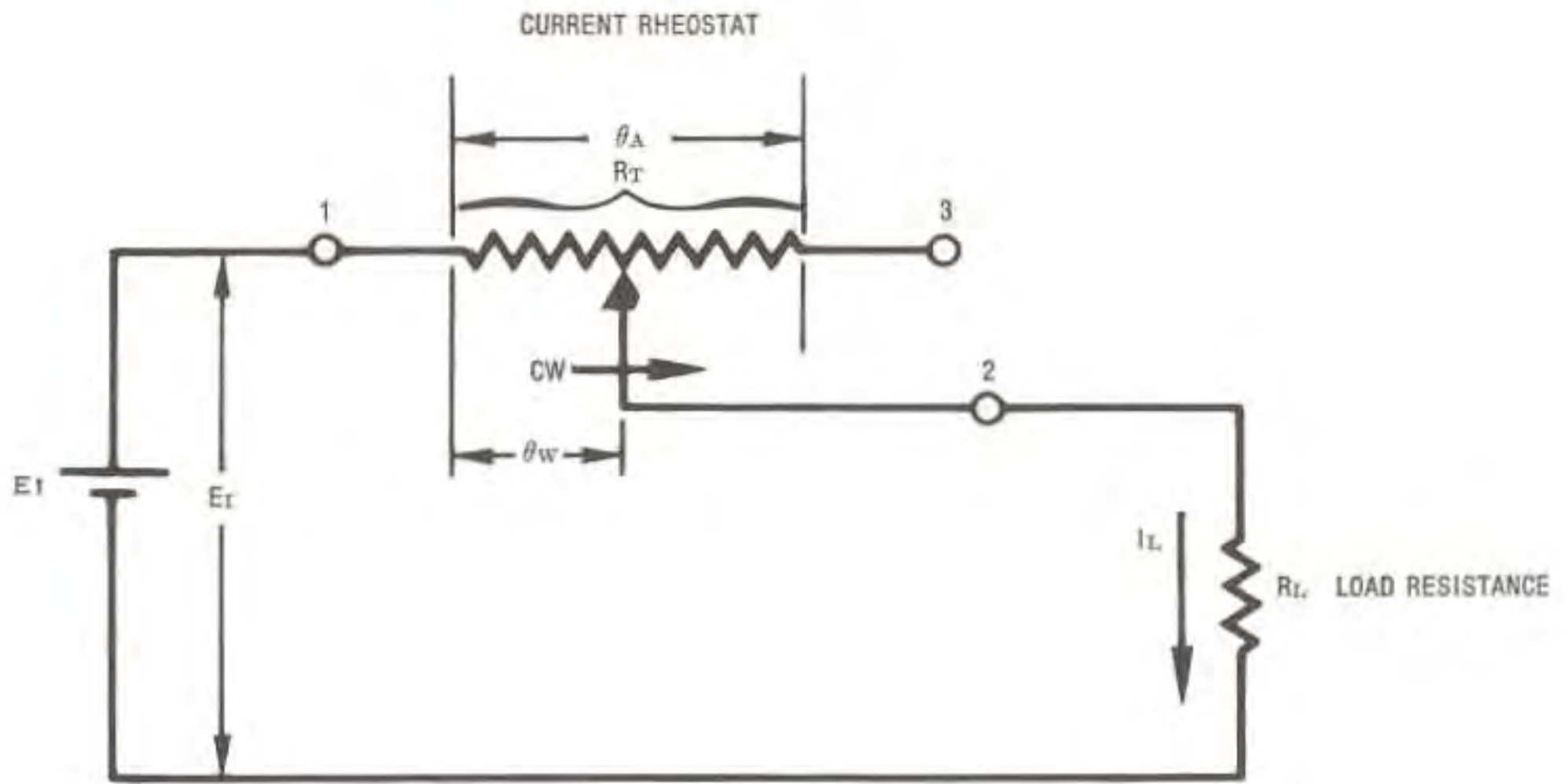

Fig. 3-18 Potentiometer's variable resistance used to control a load current



terminal, the current control curves will be as shown in Fig. 3-18B. If terminal 3 is chosen as the second terminal, the current control curves will be a mirror image of those shown in Fig. 3-18B. The only criteria for choosing terminal 1 or 3 is the user's preference for current change relative to direction of wiper adjustment rotation.

**Importance of Resistance Parameters.** The tolerance of the potentiometer's total resistance is frequently not critical in voltage divider applications. This is because proper function depends upon division ratio rather than total resistance. However, in the variable current application, the total resistance becomes significant because it determines the range of resistance adjustment possible. The effects of minimum resistance and end resistance, which include contact resistance, also become more significant in this operational mode. Note, in Fig. 3-19 that the contact resistance  $R_C$  is always in series with that portion of the element supporting the current being controlled. Also, the range of resistance available for current controlling purposes lies between the device's minimum resistance  $R_M$  and total resistance  $R_T$ , subject to the tolerance bands of these parameters.

Fig. 3-20 shows the circuit and output function for a potentiometer whose minimum resistance is not equivalent to its end resistance  $R_T$ .

Figures 3-19 and 3-20 are given solely to show those resistance factors which may affect the variable resistance range of a particular device used for current control. In application, sound design procedure requires the assumption that regardless of the type of potentiometer the range of resistance variability will be at least from the absolute minimum resistance value to the minimum  $R_T$  value, i.e.,  $R_T - \% \text{ tolerance}$ .

**Adjustability.** The adjustability of in-circuit resistance  $A_R$  is a direct indication of the accuracy with which any arbitrarily selected resistance value can be achieved. The  $A_R$  specification pertains explicitly to the rheostat mode. For example, if a potentiometer having an  $A_R = 0.1\%$  is employed in an application where  $R_T = 1000\ \Omega$ , the circuit designer can expect to set any desired value of resistance in the range 0-1000  $\Omega$  within 1  $\Omega$ .

In addition to indicating resistance setting accuracy, the  $A_R$  parameter is specified together with a maximum time-to-set duration of 20 seconds. This time factor limitation assures the potentiometer user that the specified accuracy can be obtained without an extended period of trial and error.

**Effect of TC.** The temperature coefficient of resistance can be quite important when the potentiometer is to be used in the rheostat mode.

As an example, consider a cermet potentiometer having a TC of  $\pm 100\ \text{ppm}/^\circ\text{C}$  used in an environment which might experience a total temperature variation of  $80^\circ\text{C}$ . The *total resistance* could exhibit a variation due to temperature of 8,000 ppm or 0.8%. The negative shift can be compensated by choosing a TR sufficiently high or by choosing a potentiometer whose element construction has a lower TC.

**Effects of Resolution.** Potentiometer resolution limitations affect rheostat applications directly in a manner similar to its effect in the voltage divider mode. Remember, resolution is a given percentage of a wirewound potentiometer's total resistance, and its effect becomes increasingly important as the total in-circuit resistance is reduced.

Consider an example where a 10,000 ohm potentiometer, having a specified resolution of 0.4%, 40  $\Omega$ , is used to control a current through a 1000  $\Omega$  load resistance. A circuit like that shown in Fig. 3-18A could be used. Since  $R_T = 10R_L$ , curve number 3 in Fig. 3-18B is applicable. In this circuit arrangement, maximum in-circuit resistance is obtained with the wiper in the full clockwise position. With the potentiometer at the maximum resistance, the load current is minimum and if  $E_1 = 100\text{v}$ :

$$I_{L\text{min}} = \frac{E_1}{R_T + R_L} = \frac{10^2}{10^4 + 10^3} = 9.1\ \text{milliamps}$$

The total circuit resistance is 11,000 ohms ( $10^4 + 10^3$ ) and the chosen potentiometer resolution is 40 ohms. Since 40  $\Omega$  is .36% of 11,000  $\Omega$ , the resolution of load current is:

$$.0036 \times 9.1 = .03\ \text{milliamps}$$

When the potentiometer is at its minimum resistance, the load current is maximum or:

$$I_{L\text{max}} = \frac{E_1}{R_L} = \frac{10^2}{10^3} = 100\ \text{milliamps}$$

The maximum load current must never exceed the manufacturer's maximum wiper current rating.

The total circuit resistance is now 1000 ohms,  $R_L$  alone. Since 40  $\Omega$  is 4% of 1000  $\Omega$ , the resolution of load current is:

$$.04 \times 100 = 4\ \text{milliamps}$$

The preceding example and curve number 3 in Fig. 3-18B demonstrate that the large ratio of  $R_T$  to  $R_L$  required for wide range current adjustment is obtained with a corresponding sacrifice in load current resolution at the higher current (lower resistance) settings. Curves 1 and 2 in



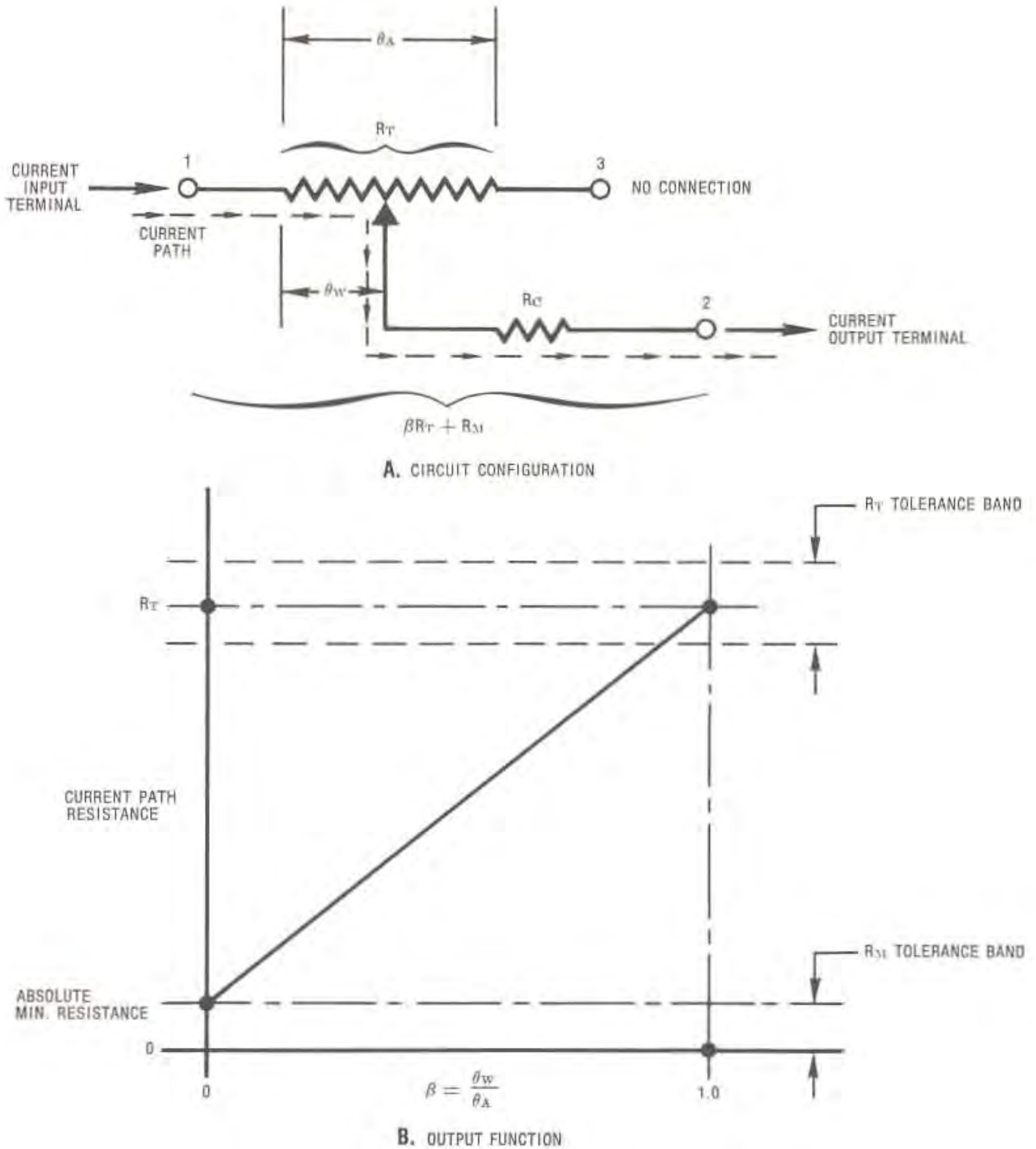

**Fig. 3-19** Variable current rheostat mode when  $R_M = R_E$

Fig. 3-18B show that a smaller current adjustment range is provided by lower ratios of  $R_T$  to  $R_L$  but load current resolution is relatively constant over the entire adjustment range.

**Power Rating as a Rheostat.** The power rating specification given on manufacturer's data sheets applies to the potentiometer in the voltage divider mode as discussed previously. In that application, the power dissipation may be viewed as distributed uniformly along the entire element. When the unit is to be used in the rheostat or two-terminal mode, only a fraction of the total element may be dissipating power for a given setting of the movable contact. That is, as

the wiper is moved from one end of the element to the other, the length of the active portion of the element also changes.

An acceptable method of relating the published power rating to the specific rheostat application is to compute a maximum allowable current. This may be done using the following equation:

$$I_M = \sqrt{\frac{P}{R_T}} \quad (100 \text{ ma, absolute maximum})$$

where  $P$  is the allowable maximum power dissipation taken from the manufacturer's data



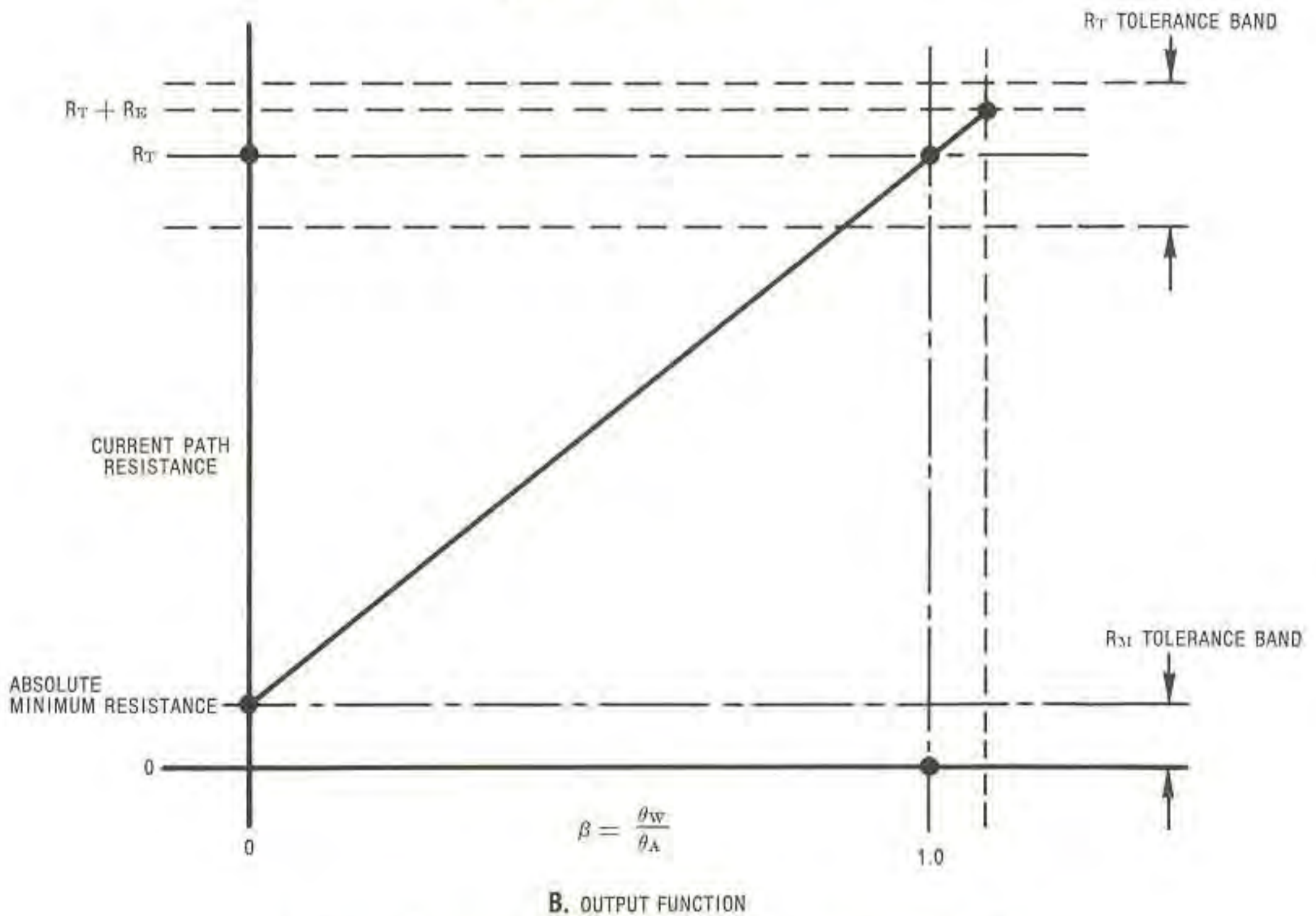
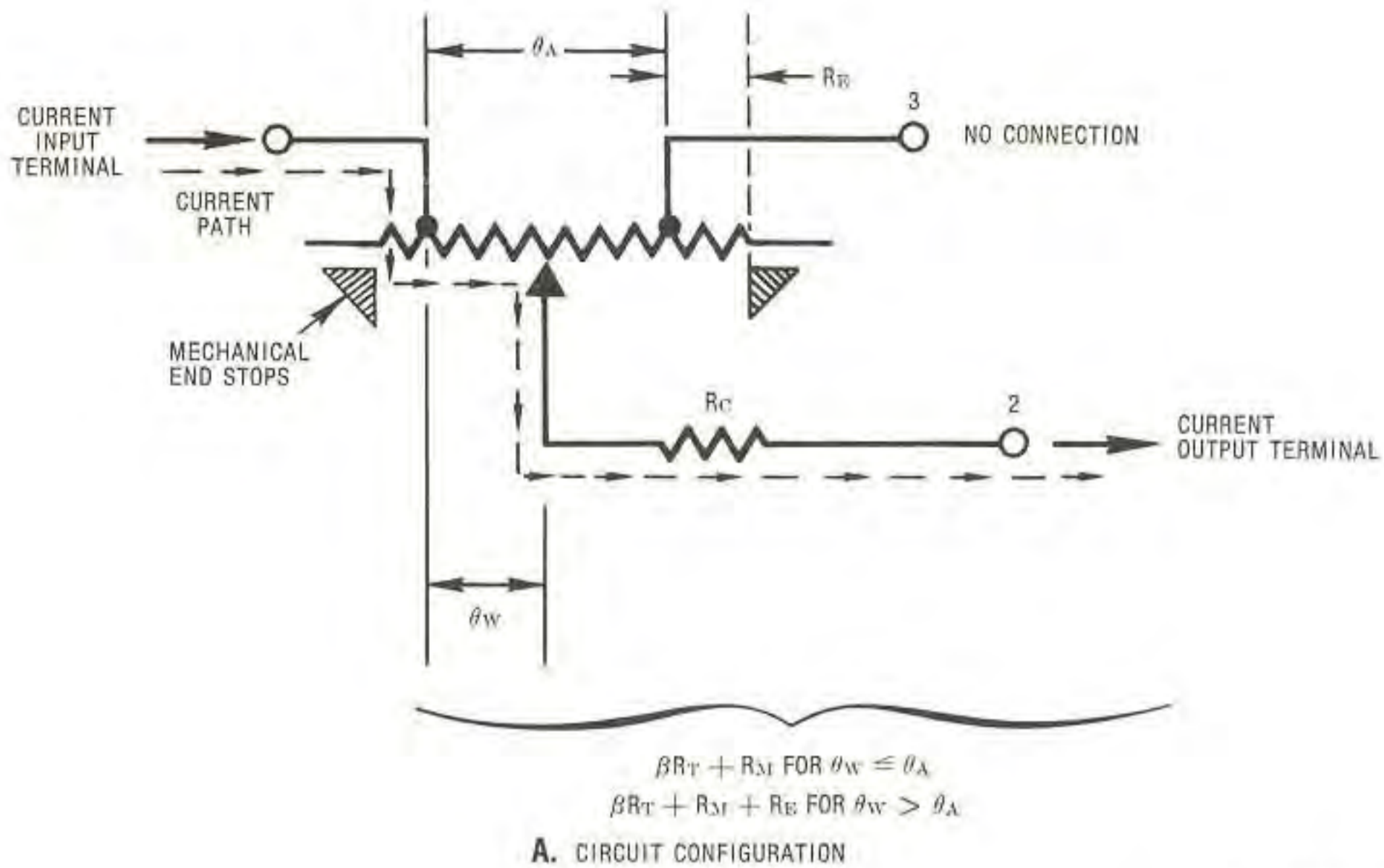

**Fig. 3-20** Variable current rheostat mode when  $R_M \neq R_E$

sheet and  $R_T$  is the total resistance. If the power is expressed in watts and the resistance in ohms, the current will be given in amps.

A further restriction on maximum current is necessary due to the two-terminal mode of operation. Unlike the voltage divider mode, the rheostat requires the total current flowing

through the resistive element to pass through the wiper circuit. The pressure contact junction of the wiper and element is not always capable of currents as high as the element alone. As already mentioned, the power rating for the voltage divider mode assumes an insignificant wiper current. Therefore, the maximum current in the



rheostat mode must be limited to the maximum allowable wiper current for the particular potentiometer being used.

100ma is a common maximum wiper current rating for most wirewound and cermet type units. The manufacturer's data sheet, for the particular unit being considered, should be consulted to ascertain the limiting value of wiper current for rheostat applications.

Once again, refer to the circuit and response curve of Fig. 3-18. The function of the potentiometer is to vary the current through load resistor  $R_L$ . When the potentiometer is adjusted fully counterclockwise, the only resistance remaining in the circuit will be that of the load resistor. This is the lowest total circuit resistance condition, hence the high current condition of the circuit. In this state, the total current in the circuit must be limited to the maximum value explained in the previous paragraph. Relating this limitation to circuit voltage and load resistance:

$$\frac{E_L}{R_L} = \sqrt{\frac{P}{R_T}} \quad (100 \text{ ma, absolute maximum})$$

As the wiper is caused to move clockwise, more resistance will be added into the circuit and, therefore, the total current will decrease remaining below the maximum allowable magnitude. The current flowing through the wiper and, hence through the load resistor, is graphically represented in Fig. 3-18B. Applying this maximum current limitation to a rheostat design will insure that the maximum power rating of the potentiometer will never be exceeded.

Using the maximum current limit is only slightly conservative for potentiometers which have rather poor thermal characteristics. For those units which have a good thermal path in the element structure, the maximum power which can safely be dissipated is somewhat larger than that limited by the maximum current calculation. Potentiometers designed specifically for power control or other high power operations have elements wound on an insulated metal core which aids in the distribution of heat. Such potentiometers can have a maximum power limit in the 20 to 30 percent travel range that is twice the 20 to 30 percent of the value indicated by the maximum current calculation.

Some cermet potentiometer designs also have good thermal characteristics, and hence a higher permissible power for limited element applications. Do not assume that the potentiometer will never be adjusted to a particular setting. Always assume that any position is possible and design for that possibility.

**Controlling the Adjustment Range.** The potentiometer, when used in the rheostat mode, provides a range of resistance from the absolute minimum resistance to the TR. Fixed resistors may be added to alter the adjustment range. Fig. 3-21 shows five basic arrangements and gives formulas for the resulting resistance ranges. Note that the effects of absolute minimum resistance need only be considered in conjunction with minimum settings.

A single series resistor  $R_1$  as shown in Fig. 3-21B, provides an effective offset (equal to its value) to the resistance parameters. The resulting output function is still a linear function of relative wiper travel. The effect of  $R_1$  is most pronounced at the minimum resistance setting and is often necessary to prevent excess current flow. In all instances, analogous to Figs. 3-21A and B, the total circuit current passes through the potentiometer's wiper circuit.

Placing a fixed resistor in parallel with the potentiometer's element as in Fig. 3-21C, has its most significant effect when the wiper is positioned fully clockwise. The resulting output function is a nonlinear function of travel as illustrated by Fig. 3-22. At the minimum resistance setting, the absolute minimum resistance of the potentiometer is shunted by  $R_2$  resulting in a resistance effectively lower than the minimum resistance. This condition is indicated as approximately  $R_M (\sim R_M)$  on the chart of Fig. 3-21.

Adding a second resistor in the manner shown in Fig. 3-21D, provides the same type of output function shown in Fig. 3-22, but all resistance values are increased by an amount equal to  $R_1$ . Note that in Fig. 3-21, circuit D is simply the combination of circuits B and C.

In the final arrangement shown in Fig. 3-21E, the shunt resistor  $R_2$  is placed in parallel with the series string of the potentiometer TR and  $R_1$ . The minimum resistance becomes the parallel equivalent of  $R_1$  and  $R_2$ . The maximum terminal resistance is the parallel equivalent of  $R_2$  and the sum of  $R_1$  and  $R_T$ . This configuration permits the control of currents higher than the device's maximum current rating. When the ratio of  $R_1$  to  $R_2$  is large, most of the total circuit current flows through  $R_2$ , and only a small portion flows through the potentiometer.

The circuit arrangement of Fig. 3-21E is frequently used where the potentiometer is to provide some small fractional adjustment in the equivalent resistance of a fixed resistor. For example, assume that  $R_1$  is equal to  $10R_2$ . Fig. 3-23 shows the resulting output functions obtained for two values of  $R_T$ . When  $R_T = 10R_2$ , the total effective circuit resistance varies from about  $0.91R_2$  to a little over  $0.95R_2$ .



CIRCUIT ALL CASES CW→	RESISTANCE PARAMETERS (2)		
	GENERAL $f\left(\frac{\theta_W}{\theta_A}\right)$	MINIMUM (1)	MAXIMUM
	$\beta R_T$	$R_M$	$R_T$
	$\beta R_T + R_1$	$R_M + R_1$	$R_T + R_1$
	$\frac{\beta R_T R_2}{R_2 + \beta R_T}$	$\sim R_M$ LOAD CURRENT CRITICAL	$\frac{R_2 R_T}{R_2 + R_T}$
	$\frac{\beta R_T R_2}{R_2 + \beta R_T} + R_1$	$\sim R_M + R_1$	$\frac{R_2 R_T}{R_2 + R_T} + R_1$
	$\frac{R_2 (\beta R_T + R_1)}{\beta R_T + R_2 + R_1}$	$\frac{R_2 (R_M + R_1)}{R_M + R_2 + R_1}$	$\frac{R_2 (R_T + R_1)}{R_T + R_2 + R_1}$

1. IN THE MAJORITY OF APPLICATIONS, MINIMUM RESISTANCE CAN BE NEGLECTED
2. IN ALL CASES, THE RESISTANCE PARAMETERS ARE MEASURED BETWEEN THE CIRCUIT-POINTS INDICATED BY THE SOLID DOTS, ● ●

LEGEND:  
 $R_M$  = MINIMUM RESISTANCE  
 $R_T$  = TOTAL RESISTANCE  
 $\beta = \frac{\theta_W}{\theta_A}$

Fig. 3-21 Fixed resistors vary the adjustment range

If the value of  $R_2$  is made 7.5% higher than the center of the desired adjustment range, then the composite circuit allows an adjustment of about  $\pm 2\%$  around the center value. The output function is slightly nonlinear in the end regions, but this does not represent a problem for most trimming applications.

When the relative value of the potentiom-

eter's total resistance is increased to  $100R_2$ , a greater range of adjustment is obtained. However, the resulting output function becomes even more nonlinear and most of the adjustment will occur in the lower 50% of potentiometer

travel, i.e., where  $\frac{\theta_W}{\theta_A} \leq 0.5$ .



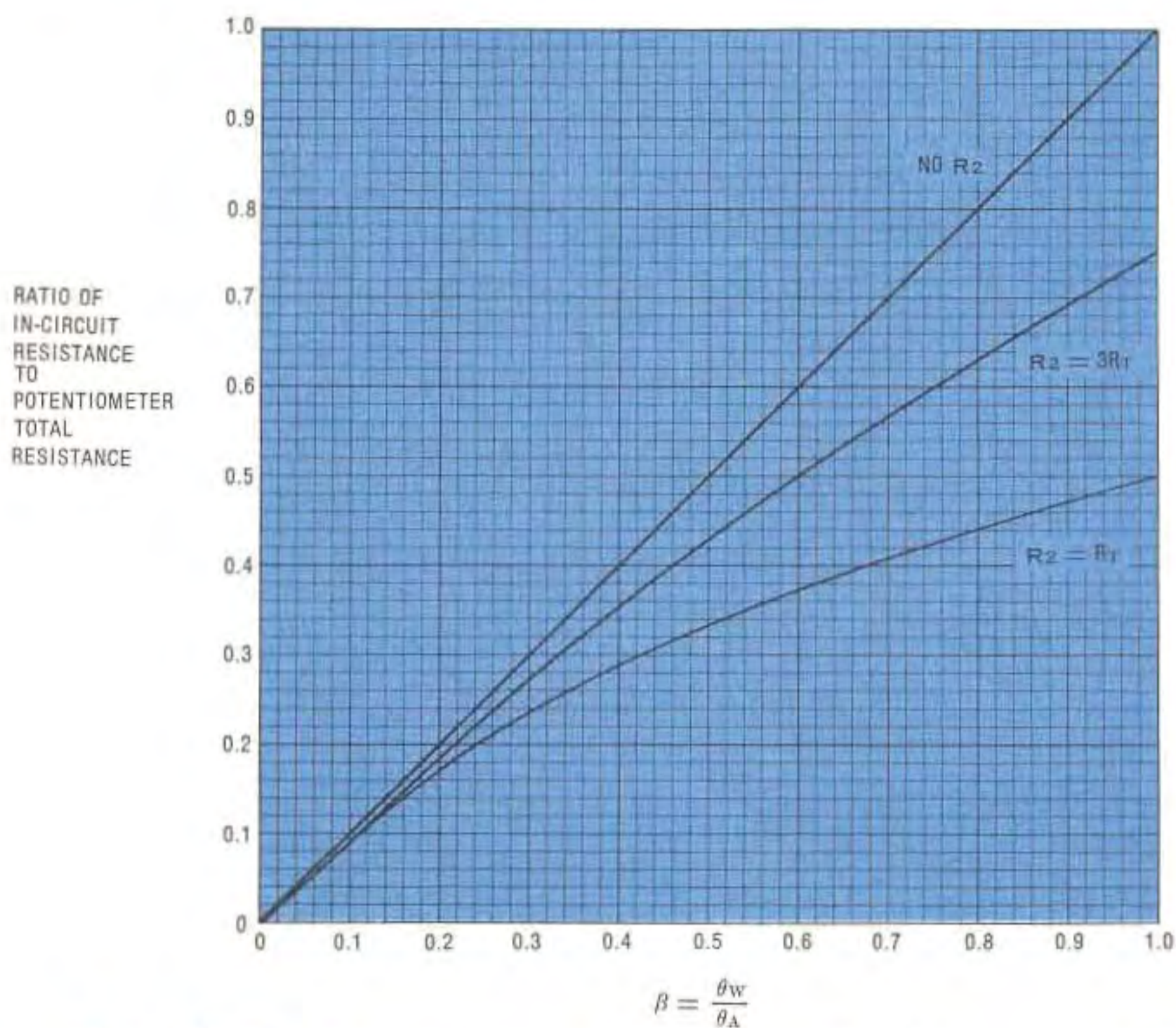

**Fig. 3-22** A fixed resistance in parallel with a variable resistance controls the range  
See Fig. 3-21C

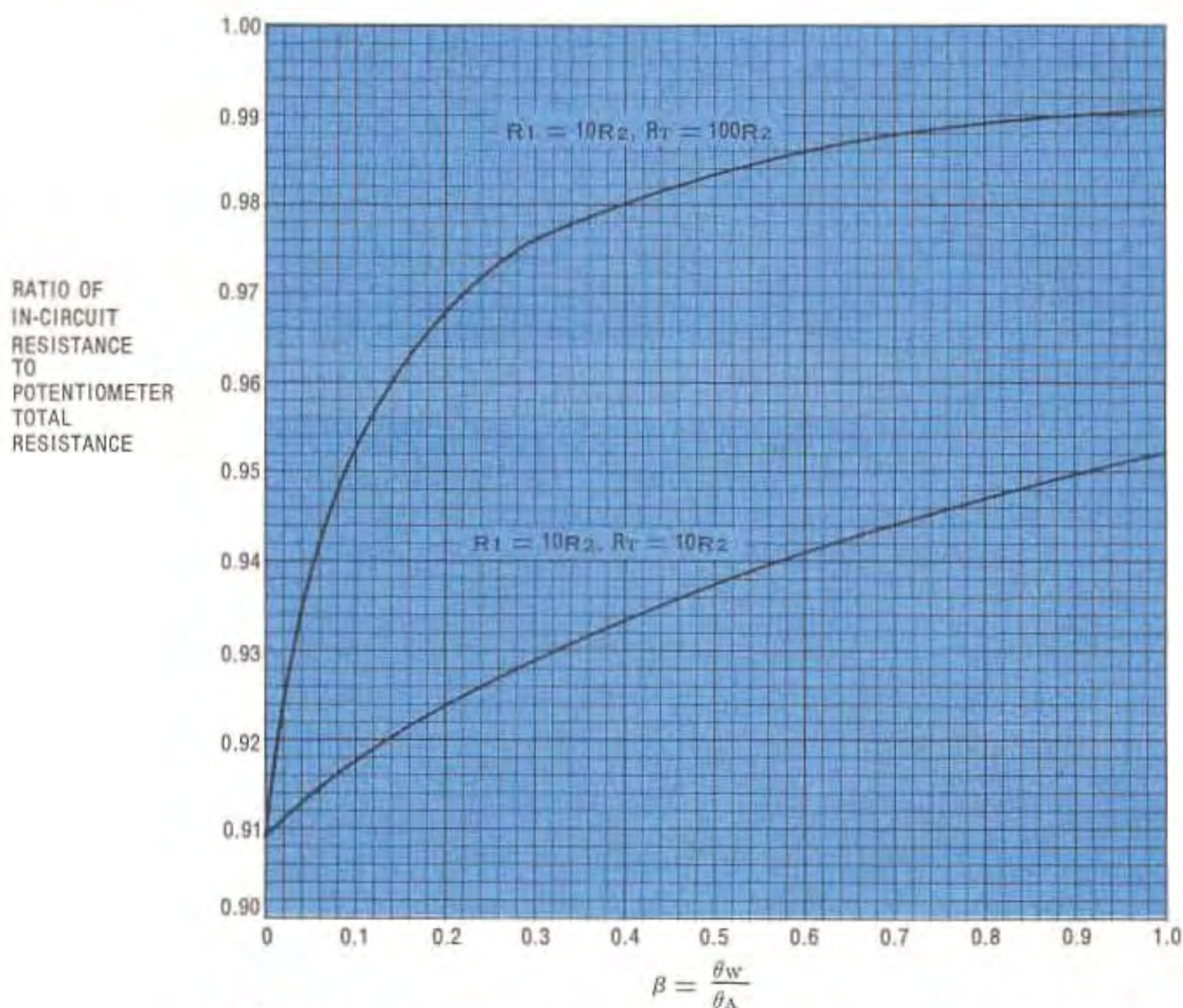

**Fig. 3-23** Normalized output function for circuit configuration of Fig. 3-21E



**DATA INPUT**

Another basic application of potentiometers is that of data input. Although the actual circuitry may be that of either the variable voltage divider or the variable current mode, there are certain special considerations of data input which deserve discussion.

In this class of application, the potentiometer serves as a means whereby an operator may inject some known value of a given control function into a system by use of some form of dial or scale attached to the potentiometer. Data input applications can vary widely from the simple volume or tone control on an audio amplifier to the high precision stable input for an analog computer.

**Dials.** Simple dials for single turn potentiometers may be silk-screened or engraved on the mounting panel to provide an easy means for data input with moderate accuracy. The scale might be linear or designed for varying degrees of nonlinearity anywhere from a minor compen-

sation for loading error to logarithmic. Fig. 3-24 illustrate some typical examples.

Various types of dials for use with multiturn potentiometers are also available. One basic style, illustrated in Fig. 3-25, not only displays the number of dial turns but provides a vernier

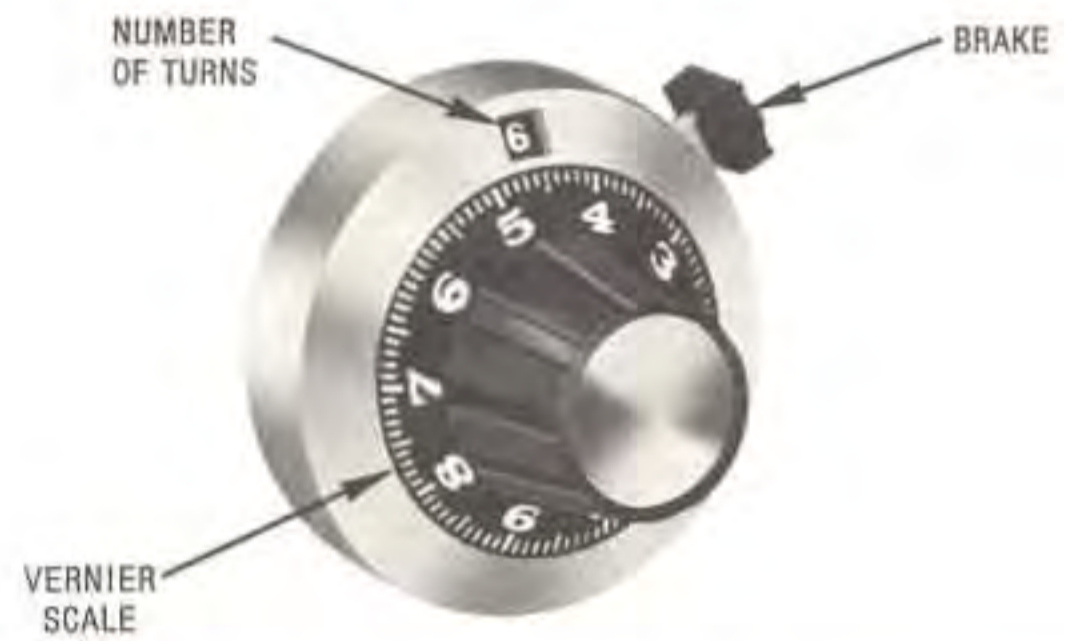

**Fig. 3-25** An example of a turns counting dial for a multiturn potentiometer



**Fig. 3-24** Typical screened or engraved dials for single turn data input



dial for very accurate fractional division of each particular turn. Note the braking feature which allows a particular setting to be locked in and held until the brake is released.

Another style of multiturn dial, shown in Fig. 3-26, resembles a clock face. The short or *hour* hand indicates the number of turns while the long or *minute* hand shows fractional turns.



**Fig. 3-26** A multiturn dial with a clocklike scale

For some applications, a *digital* readout dial is more practical. Fig. 3-27 shows several examples.

Some multiturn potentiometers are available with integral dials of either the clock-face or digital type. Use of this style can result in space savings and lower installation costs.

**Mechanical Factors.** Designs using dials with potentiometers to aid in data input must consider not only the electrical characteristics of the potentiometer but also certain mechanical factors as well.

Readability is an important consideration. For a simple single turn dial, readability is typically 1% to 2% of the total mechanical travel. For multiturn dials, the readability is typically 1% of a single rotation. This results in a readability of 0.1% of full scale for a ten-turn device.

Mechanical backlash can contribute some error if the dial is not directly attached to the potentiometer's shaft. The same dial reading obtained by approaching from different directions can result in slight differences in potentiometer output.

The effective resolution of a potentiometer-dial data input team is a combination of the elec-

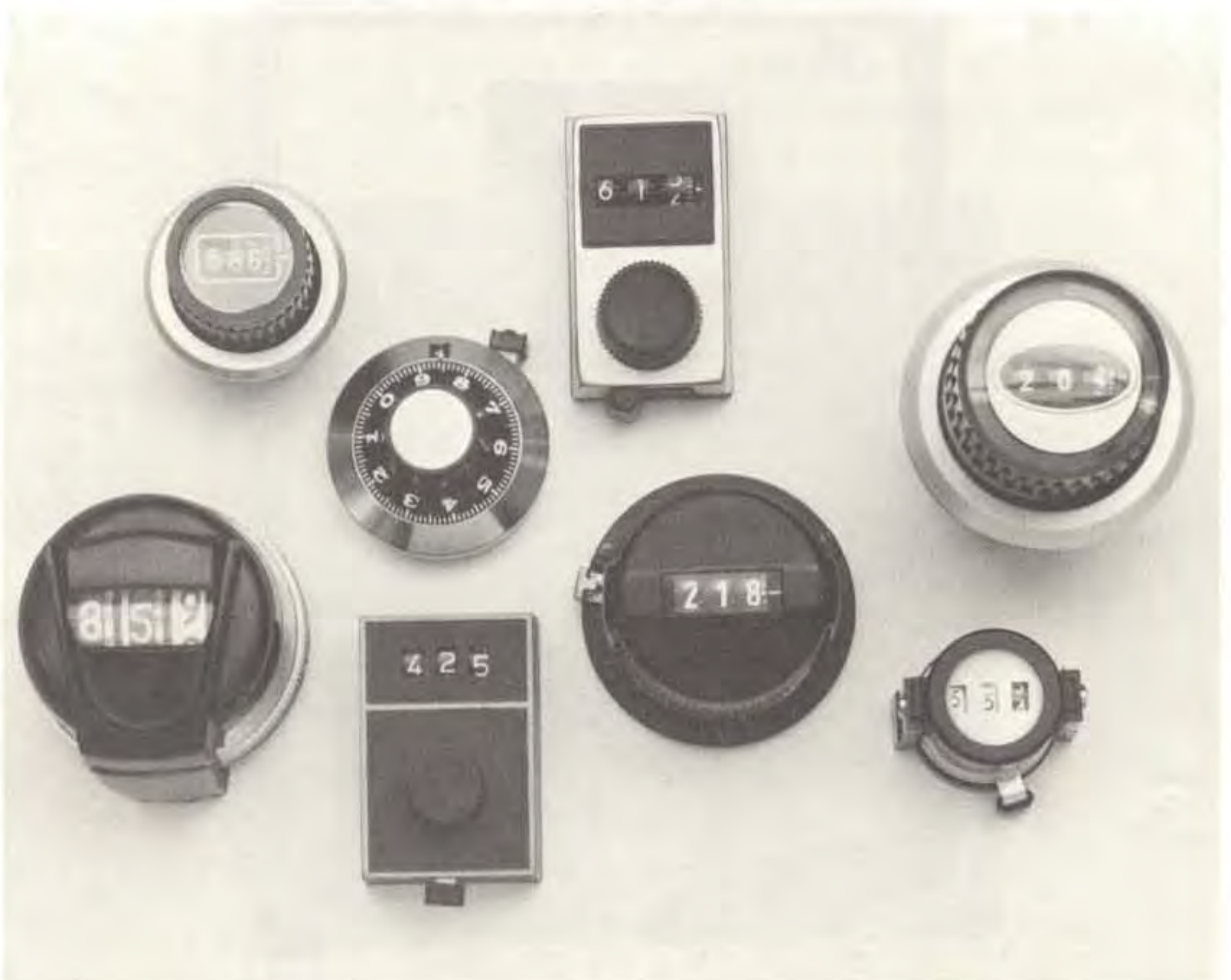

**Fig. 3-27** Examples of digital type, multiturn dials



trical characteristics of the potentiometer along with the possible errors due to mechanical factors.

Some dials rely on the potentiometer construction to provide end stops as a limit to mechanical travel, while other applications might require the added protection of an additional limit to the maximum travel.

**Offsets.** Some applications profit from a mechanical offsetting arrangement where the minimum position of the potentiometer may not be zero but some fractional portion of full scale. Consider the voltage divider shown in Fig. 3-28.

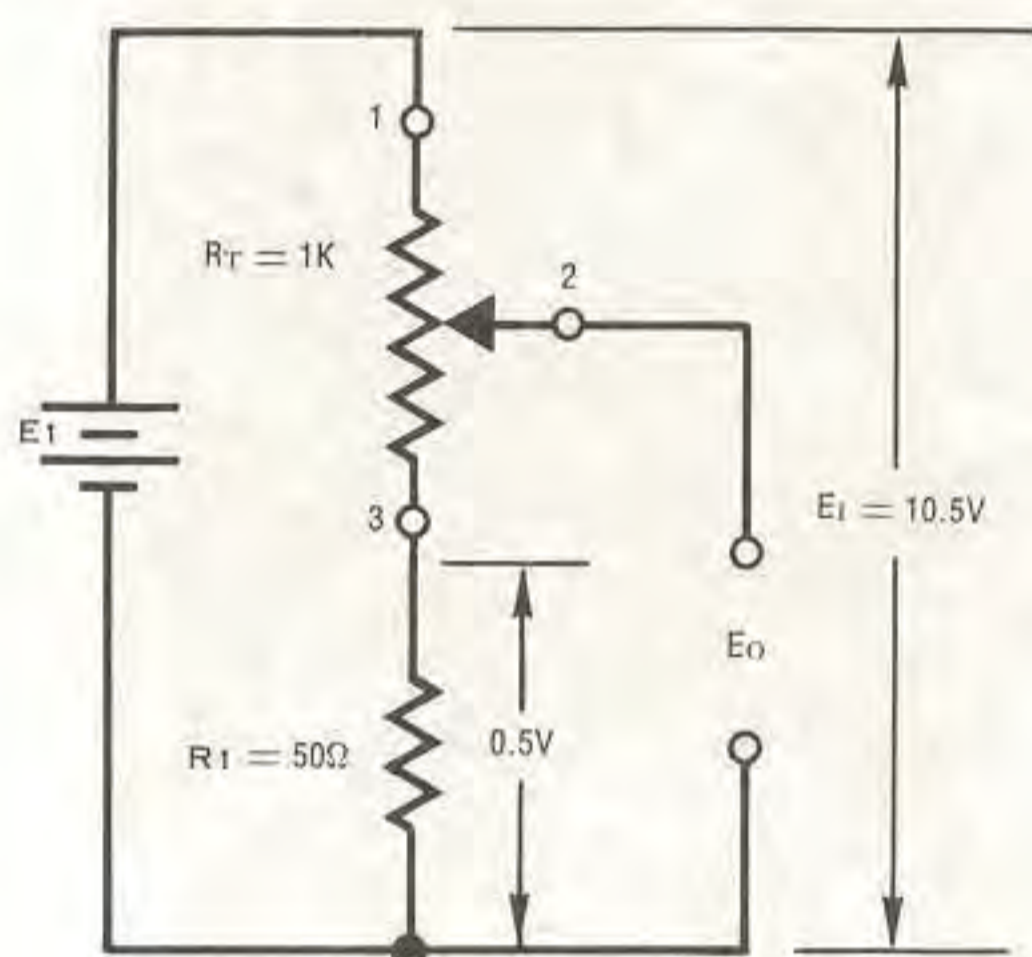

**Fig. 3-28** Example of offsetting to modify the covered range of a data input potentiometer

As the potentiometer travel is increased from minimum (1) to maximum (3), the output voltage changes from  $0.5V$  to  $10.5V$ . Some dials will permit mechanical offsetting to display the actual voltage output. Usually these dials are designed to display 15 or more turns and thus can provide up to 50% offset on a ten-turn potentiometer.

Optimum accuracy of offset and adjustment range can be achieved with two potentiometers on each side of the data input potentiometer as demonstrated in Fig. 3-29.

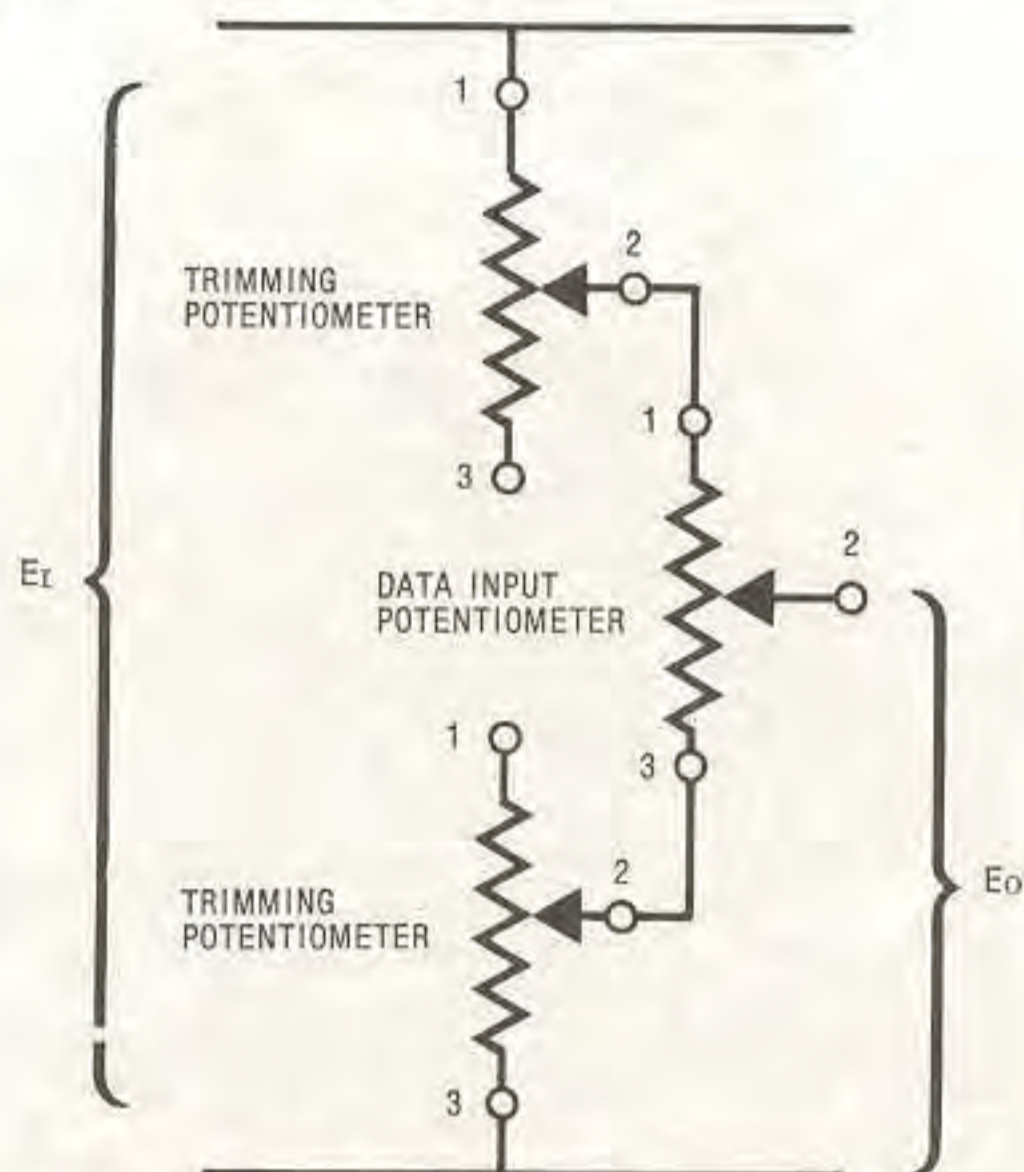

**Fig. 3-29** A circuit configuration to optimize offset and adjustment range of data input potentiometer

**Logging Charts and Tables.** Appropriate dial scales may be designed and applied to the potentiometer mounting panel for single turn devices used where a nonlinear input is required. However, multiturn dials are designed to provide only a linear readout. When a data input application requiring a nonlinear function from a multiturn potentiometer-dial combination, a logging chart or table to relate linear dial readings to the nonlinear variable must be used. The equipment operator is then provided with the proper conversion table and uses it to determine any specific setting. This approach is also useful in making overall system conversions in an expedient manner.

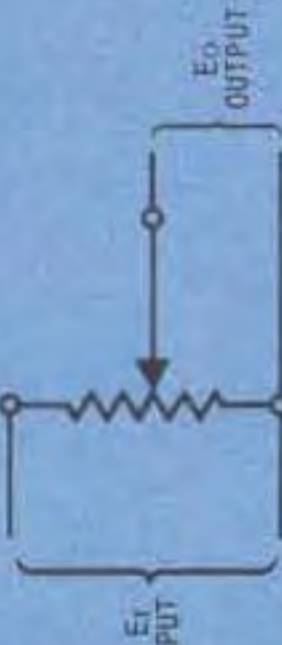
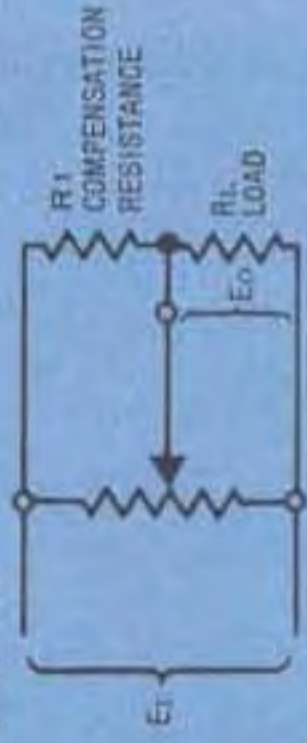

CIRCUIT CONFIGURATION	PAGE	DESIGN CONSIDERATIONS
<p><b>VARIABLE VOLTAGE DIVIDER MODE</b></p> 	51 52 53	<p><b>FUNCTION:</b> To provide an output voltage in reduced proportion to its input voltage.</p> <p><b>OUTPUT VOLTAGE:</b> <math>E_o = \beta E_i</math>; <math>\beta = \frac{r_w}{R_A}</math></p> <p><b>POWER RATING:</b> Manufacturer's data sheet. Linear derating factor between two operating points:  <math>P = \frac{P_A - P_B}{T_A - T_B}</math> Where <math>P_A</math> is rated power at temperature <math>T_A</math> and <math>P_B</math> is rated power at temperature <math>T_B</math>.</p> <p>Allowable power dissipation at any temperature <math>T_D</math> within the operating temperature range:  <math>P_D = P_A + \rho(T_D - T_A)</math>  <math>P_A</math> is specified power at <math>T_A</math> (the low limit of the operating temperature range.)</p>
<p><b>LOADED VOLTAGE DIVIDER WITH COMPENSATION</b></p> 	54 54 57 62	<p><b>MAXIMUM ERROR:</b> Due to output load (no compensation)  <math>\delta = -\frac{R_x}{R_c + 4R_L}</math> <math>R_x</math> IS TOTAL RESISTANCE</p> <p><b>MAXIMUM LOAD CURRENT:</b>  <math>I_{Lmax} = \frac{E_i}{R_L}</math>, never exceed manufacturer's absolute maximum rating</p> <p><b>COMPENSATION:</b>  Refer to figures 3-11, 3-12, 3-13</p> <p><b>OPTIMIZE RESOLUTION:</b> Intentional loading, Figures 3-15, 3-16 and 3-17</p>
<p><b>VARYING THE ADJUSTMENT RANGE</b></p>		



# APPLICATION AS A CIRCUIT ADJUSTMENT DEVICE



Chapter

4

*“Design is revealed in terms of a number of fundamental principles and relationships . . . One must realize that design focuses more attention on the individual to structure his thinking along guided and hopefully productive paths. . .”*

*Percy H. Hill*

*The Science of Engineering Design*

## INTRODUCTION

Potentiometers were considered from their elemental circuit functions in the previous chapter. A broader look at applications shows their use as circuit adjustment, control, and precision devices. The latter two include the man-machine interface function; that is, communications between man and machine in the form of electronic input and output data. This chapter covers the first of these three important functions – adjustment devices.

Adjustment potentiometers can provide the means for compensation of various error sources that are not predictable quantities during the design phase, i.e., currents, resistances and voltages. The adjustments are made during final checkout and may never be needed again. These applications are commonly described as *set and forget* or *trimming* functions. The adjustment capability also permits correction for

long-term variances, e.g., component replacement or aging.

It is these adjustment capabilities – either set and forget or correction for long term variances – that have been most responsible for the potentiometer being called a *cost-effective component*. For it is often found by cost-benefit analysis that proper application of potentiometers is the most cost-effective alternative.

It would be a massive task to describe all of the possible potentiometer applications in this category and no attempt to do so is made here. A wide variety of applications will be presented to indicate typical areas where trimming potentiometers provide a valuable function.

Although the application descriptions will be brief, enough information will be included to illustrate basic adjustment techniques which may be adapted to many other circuits.



## POTENTIOMETER OR FIXED RESISTORS?

For those applications having a low probability of ever needing readjustment, the *set and forget* class, it is well known that a selected fixed resistor will yield a stable performance for a longer time duration than a rheostat connected potentiometer. Even a voltage divider potentiometer could be replaced by two fixed resistors. The basic cost of two fixed resistors may be less than that of a good adjustment potentiometer, but there are other factors which should be considered carefully.

First, compare the problems of inventory. Fine adjustment capability requires that many different values of fixed resistors be available during final checkout. If the additional cost of ordering, stocking, and handling many fixed resistors is considered, the economics of the potentiometer begins to look better.

In addition, 1% precision resistors are only readily and economically available in discrete values approximately 2% apart. If the application requires better adjustment resolution than that, then two values will have to be chosen in a two-step selection process.

Proper selection of fixed resistors requires some form of test substitution, which must be temporarily attached to the circuit in order to determine the exact value required, e.g., a decade resistance box. Care must be taken not to induce noise or stray capacitance. Proper values must be chosen by a process of reading the dials on the decade box carefully, calculating the nearest available value, then obtaining a part and installing it in the assembly by hand. This means that the instructions regarding the selection process will have to be more detailed as the skill of the operator must be higher. Also the selection operation consumes more time.

Compare this with possible automatic insertion and wave soldering of a potentiometer during assembly and a simple screwdriver adjustment during check-out. The labor cost of potentiometer installation and adjustment will be lower, and finer adjustment is practical. Negligible noise or capacitive loading is induced, and final adjustment may be made when the full assembly is complete and even inserted in a case! Thus, serious consideration of the cost-effective component — a potentiometer — is well worthwhile.

Some set and forget applications suddenly need to be remembered and reset when a field failure occurs. If a critical component must be replaced, the original adjustment must be modified to fit new conditions. The cost for field selection and installation of a precision fixed

resistor will be very high. If an adjustment potentiometer had been placed in the original design, the field service technician could instantly set the right value with very little effort. Also, no unsoldering of the old resistor and soldering of the new one would be required . . . a further saving and elimination of a risky rework operation.

## POWER SUPPLY APPLICATIONS

Many applications of adjustment potentiometers are found in power supplies. Certain parameters must be adjusted to compensate for tolerance variations of components used in the power supply assembly.

**Precise Output Voltage Adjustment.** Even in the simplest form of regulated power supply, there are usually several components whose value will influence the final value of the output voltage. Consider the simple voltage regulator circuit of Fig. 4-1. The output voltage is determined primarily by the breakdown voltage of the voltage reference (VR) diode,  $D_1$ , and the two resistors  $R_3$  and  $R_4$ . But  $E_0$  is also influenced, to a lesser degree, by the base to emitter voltage of transistor  $Q_1$  and the values of  $R_1$  and  $R_2$ .

Assume that the purchase tolerance on the VR diode is  $\pm 5\%$  at a test current value which is likely to be different from the required bias value. If 1% resistors are used for  $R_3$  and  $R_4$ , the worst-case error in the voltage divider is  $\pm 2\%$ . This gives a total worst-case error of more than  $\pm 7\%$ . Adding all of the other error possibilities will show that the possible output voltage variation due to component tolerances can be as much as  $\pm 10\%$ . This is too much for most applications.

It is possible to replace either of the two divider resistors  $R_3$  or  $R_4$  with a potentiometer connected as a rheostat, but the preferable application mode is shown in Fig. 4-2. An adjustment potentiometer  $R_5$  is used as a voltage divider to permit variation of the output voltage. The adjustment range is determined by the TR value of  $R_5$  compared to  $R_3$  and  $R_4$ . The potentiometer resistance can be chosen to provide enough adjustment range for a precise setting of the output voltage with optimum resolution, or chosen to permit a much larger variation, thus making the circuit more versatile.

If the proper trimmer is selected, economical 5% resistors can be used for  $R_3$  and  $R_4$ , provided they are relatively stable, e.g., metal film. Further economic advantage can be achieved by purchasing VR diodes with a  $\pm 10\%$  tolerance.

Always attempt to limit the adjustment range



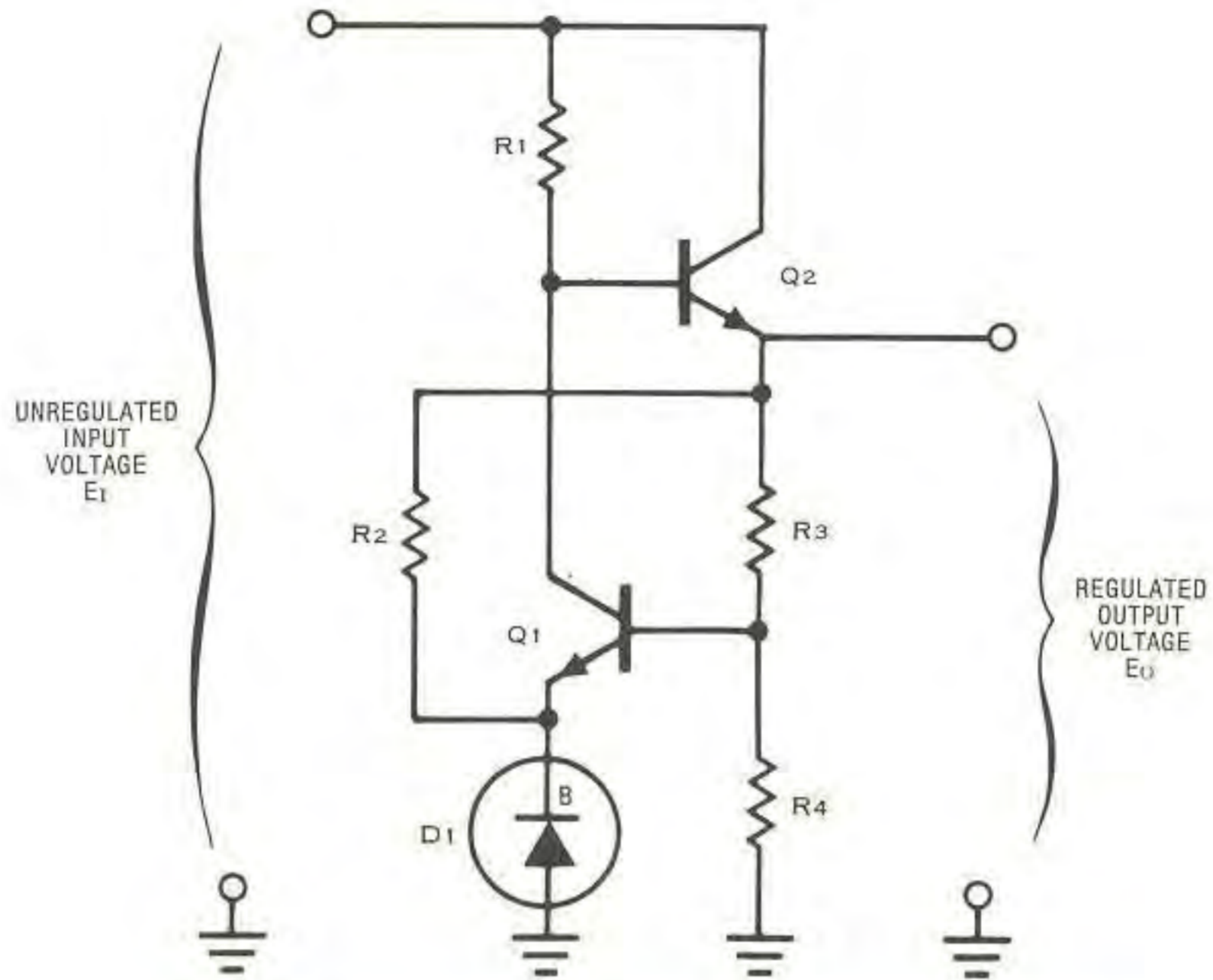

**Fig. 4-1** The output voltage of a simple voltage regulator is affected by tolerances of several components

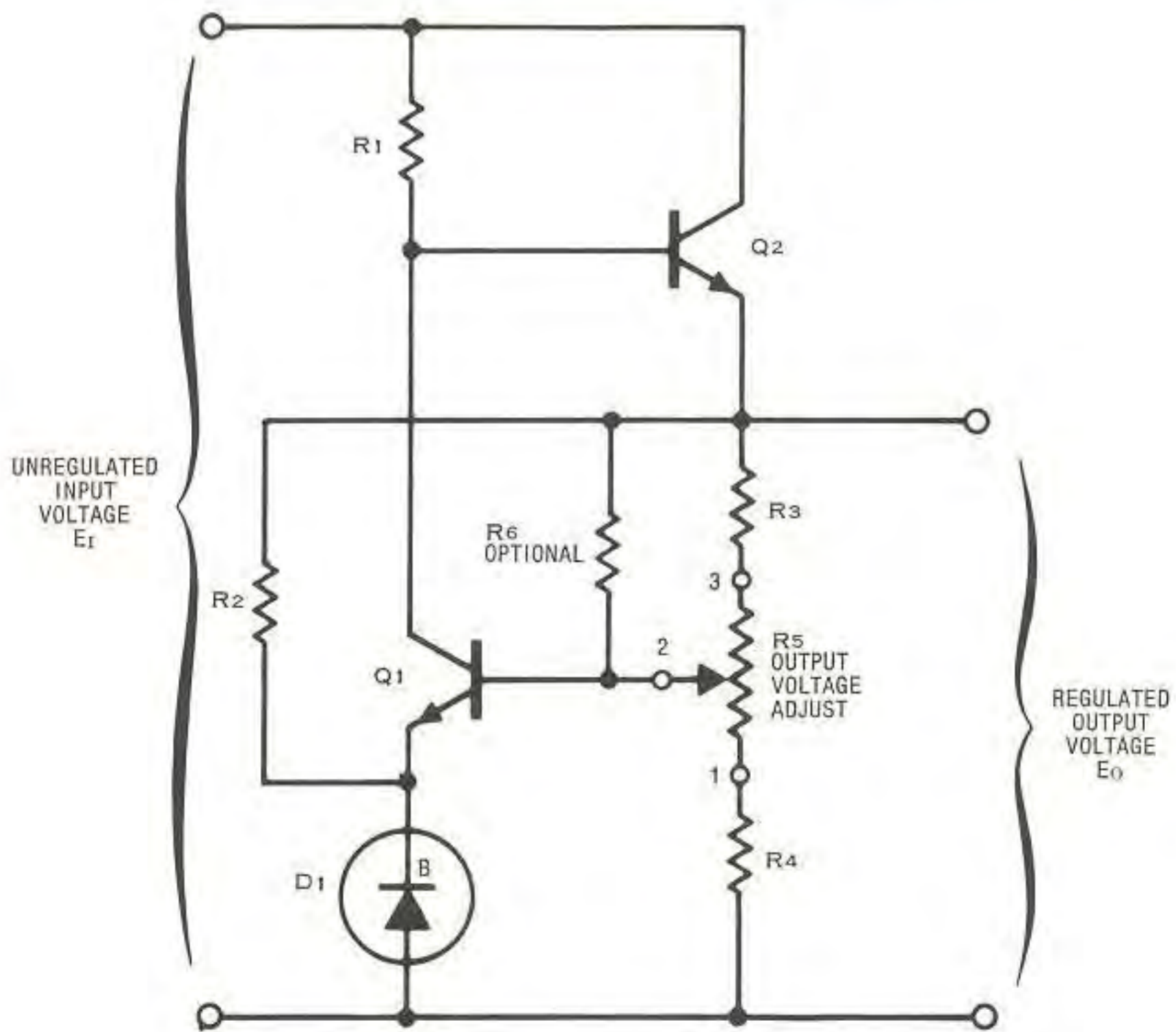

**Fig. 4-2** A single potentiometer compensates for component tolerances and permits precise adjustment of output voltage



to those values anticipated. This will optimize resolution as well as restrict output excursions. An excessive range might cause damage to other circuitry if the potentiometer is not pre-adjusted before application of power. Even if pre-adjustment is accomplished, someone is sure to set the potentiometer to any given point within its range at some time or another!

If the adjustment potentiometer is located remotely from the rest of the circuit for accessibility, consider adding an extra resistor such as  $R_6$ , shown in Fig. 4-2. Its value is not critical but should be chosen to be an order of magnitude higher than the divider resistors. The function of  $R_6$  is to provide feedback to limit the regulator output voltage in those cases where the circuit connection to the wiper terminal becomes electrically open. This can occur because an assembler failed to install a wire or, for a multitude of possible reasons, the wire breaks.

Other more elaborate power supplies may use similar adjustment schemes to facilitate a limited and controlled range of output voltage adjustment.

**Current Limit Adjustment.** Fig. 4-3 illustrates another power supply regulator that utilizes an integrated circuit. Potentiometer  $R_2$  permits output voltage adjustment, as explained in the previous paragraphs, with range limited by resistors  $R_3$  and  $R_4$ .

A second adjustment capability is included in Fig. 4-3 to permit control of the short-circuit current limit. The IC regulator will limit the output current to a value necessary to establish approximately 0.6V between the *limit* and *sense* terminals. The voltage across resistor  $R_5$  is proportional to the output current. Potentiometer  $R_1$  provides a fractional part of the developed voltage to the current limit input.

Although  $R_5$  could be replaced directly by the potentiometer, it is generally not practical because of the very low ohmic values required. It is more reasonable to choose a value for  $R_5$  that will force it to carry the output current, than select a practical value for  $R_1$  which has adequate resolution.

It may be required to place another fixed resistor,  $R_6$  in Fig. 4-3, in series with  $R_1$  to prevent

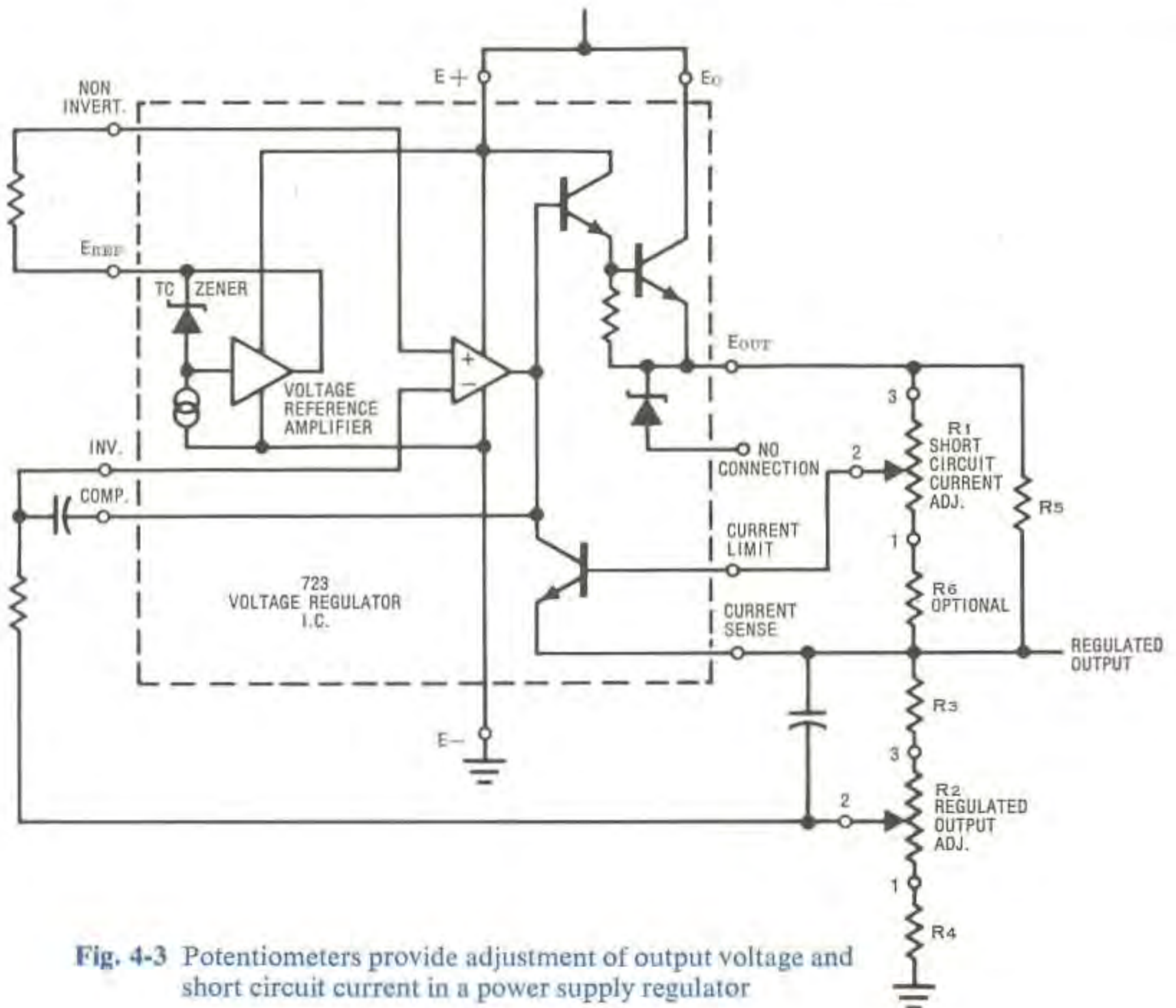

**Fig. 4-3** Potentiometers provide adjustment of output voltage and short circuit current in a power supply regulator



current limit from exceeding a given value.

**TC VR Diode Reference Supply.** A temperature compensated VR diode is frequently used as a voltage reference supply. A greatly expanded characteristic curve for a typical TC VR diode is shown in Fig. 4-4A. Note that the diode voltage is a function of temperature at any bias current above or below an optimum value.

By providing a trimming potentiometer for the bias current, adjustment of the overall temperature coefficient to its optimum value is possible. In the circuit diagram of Fig. 4-4B, potentiometer R1 provides adjustment of the current generator by varying the total resistance in the emitter circuit of transistor Q1.

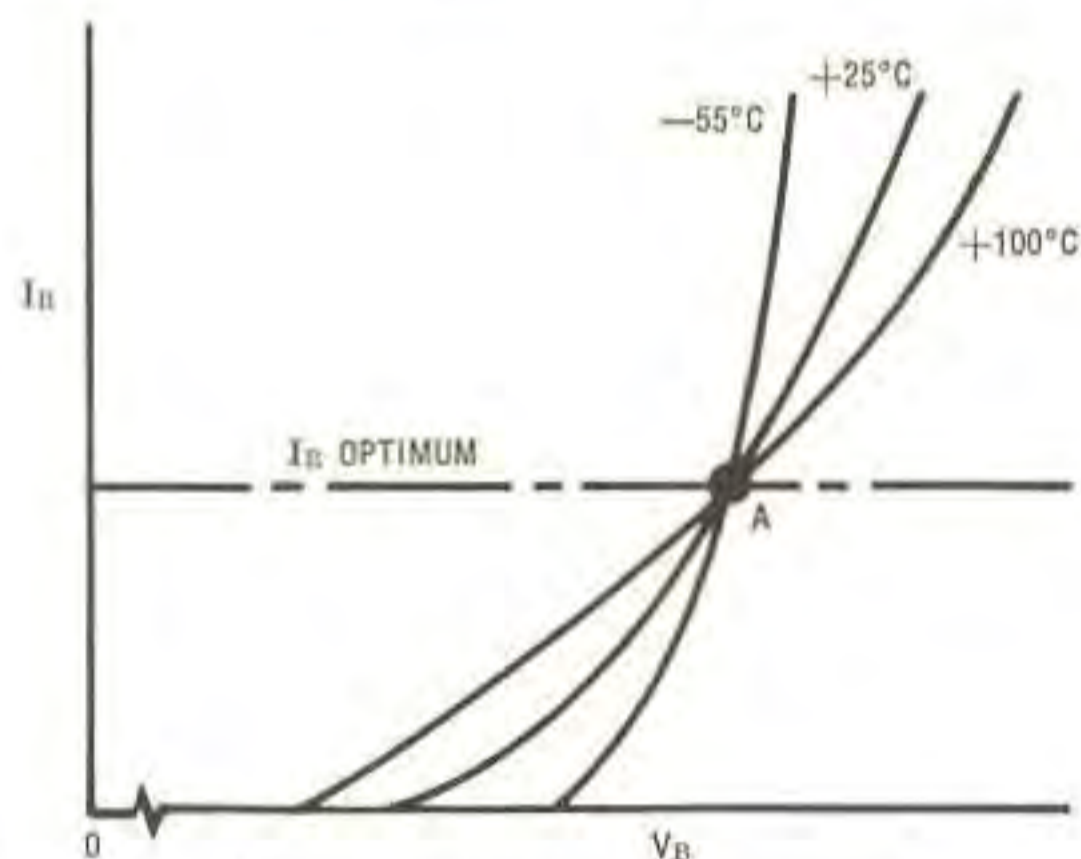

A. EXPANDED BREAKDOWN CHARACTERISTICS

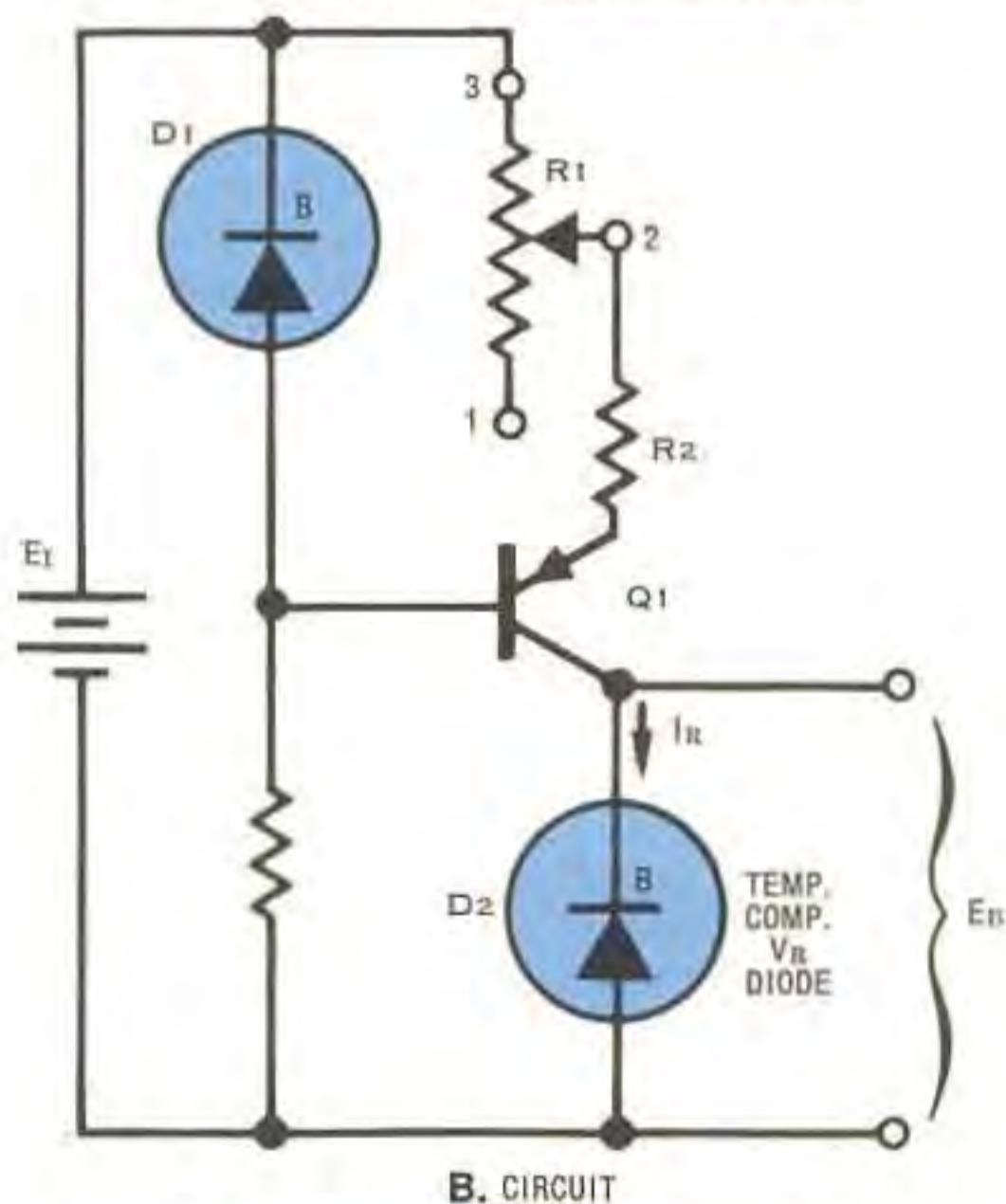

B. CIRCUIT

**Fig. 4-4** Adjustment of bias current through a temperature compensated VR diode optimizes its temperature coefficient

R2 is a current limiting resistor necessary for the condition when R1 is adjusted to its minimum value. Without R2, this condition could result in excessive current flow and severe damage to R1, Q1, and the TC VR diode, D2. Choose the values of R1 and R2 to provide the design value of bias current through D2 when the potentiometer is set to its center travel position. R1 will typically be about one fifth the value of R2 to provide an adjustment range of roughly  $\pm 9\%$ . Remember, R1's minimum setting is the high current condition and must not exceed the potentiometer's maximum wiper current rating.

**Temperature Compensating Voltage Supply.** It is often desirable to develop a temperature compensating voltage for correction of a temperature induced error within a system. Fig. 4-5 illustrates one possible circuit design.

Diode D1 is forward biased and has a forward voltage drop  $E_F$  which decreases about  $2\text{mV}/^\circ\text{C}$ . Potentiometer R2 provides a nulling adjustment to cause the output voltage  $E_O$  to be zero at a given temperature, typically  $25^\circ\text{C}$ .

As the operating temperature of D1 increases,  $E_F$  drops and the value of  $E_O$  rises by an amount controlled by trimmer R5. Thus  $E_O$  may be used as a correction voltage whose increment is adjustable for a given temperature change.

## OPERATIONAL AMPLIFIER APPLICATIONS

Integrated circuit operational amplifiers are very common and extremely useful components. Potentiometers are used to adjust for an equivalent zero offset voltage or to set the overall gain in the op-amp's feedback circuit.

**Offset Adjustment.** Many IC operational amplifiers provide access to the internal circuitry for the purpose of nulling the offset voltage with an external potentiometer. Fig. 4-6 illustrates three methods for common IC types.

In Fig. 4-6A, the potentiometer is tied directly between pins 1 and 5 with the wiper connected directly to the negative dc supply. The other two circuit arrangements, Fig. 4-6B and 4-6C, are more complicated.

The circuit arrangement given on some op-amp data sheets calls for a potentiometer having a TR of 5 megohms. Cermet or wirewound potentiometers are preferable for stability, even though any variations in potentiometer resistance will produce only second order effects in the actual drift performance of the amplifier. However, 5 megohms is beyond the range of wirewound and is available in only a few cermet models.

The simple circuit arrangement of Fig. 4-6B accomplishes the offset nulling requirement, with



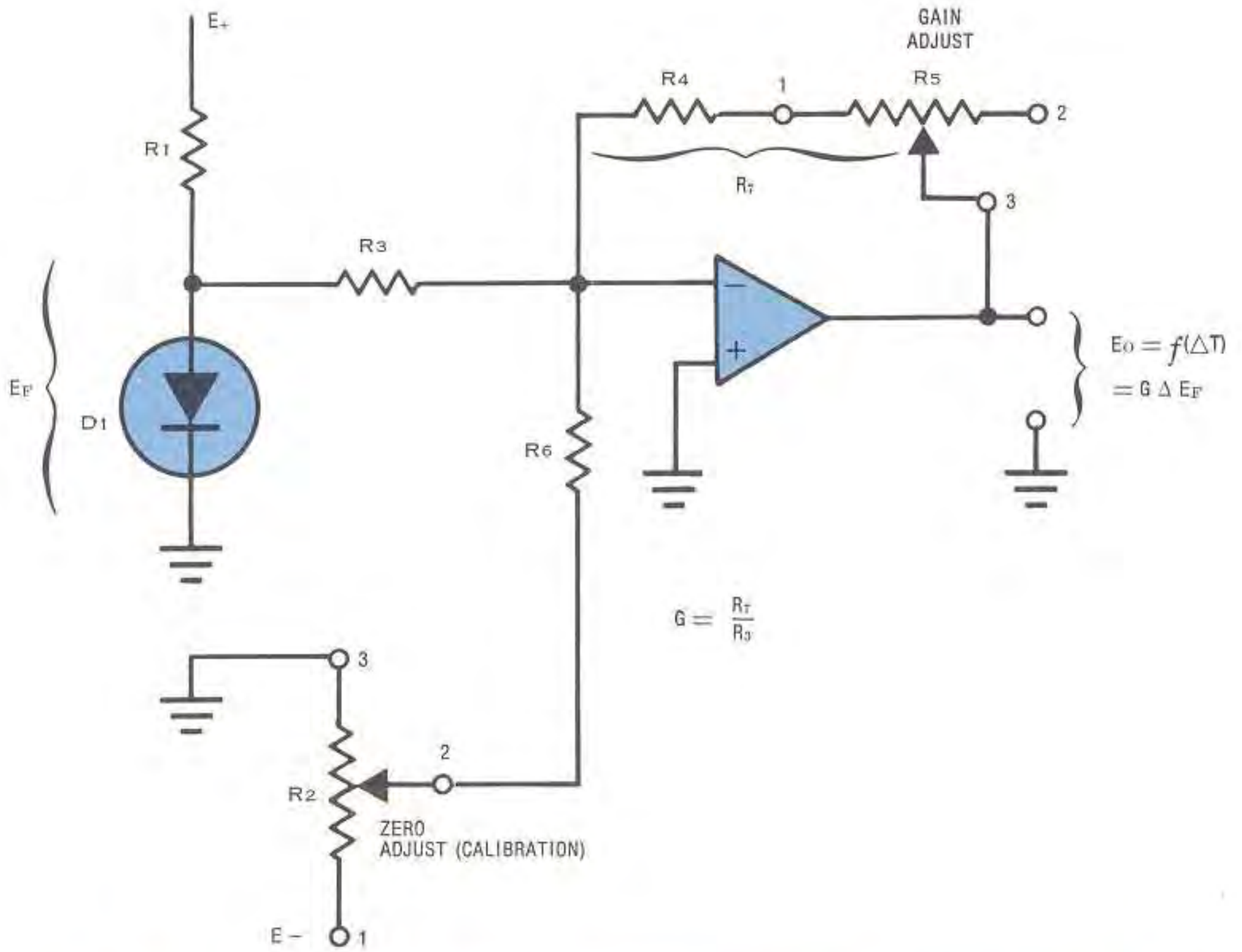

Fig. 4-5 A circuit for generation of a variable temperature compensating voltage

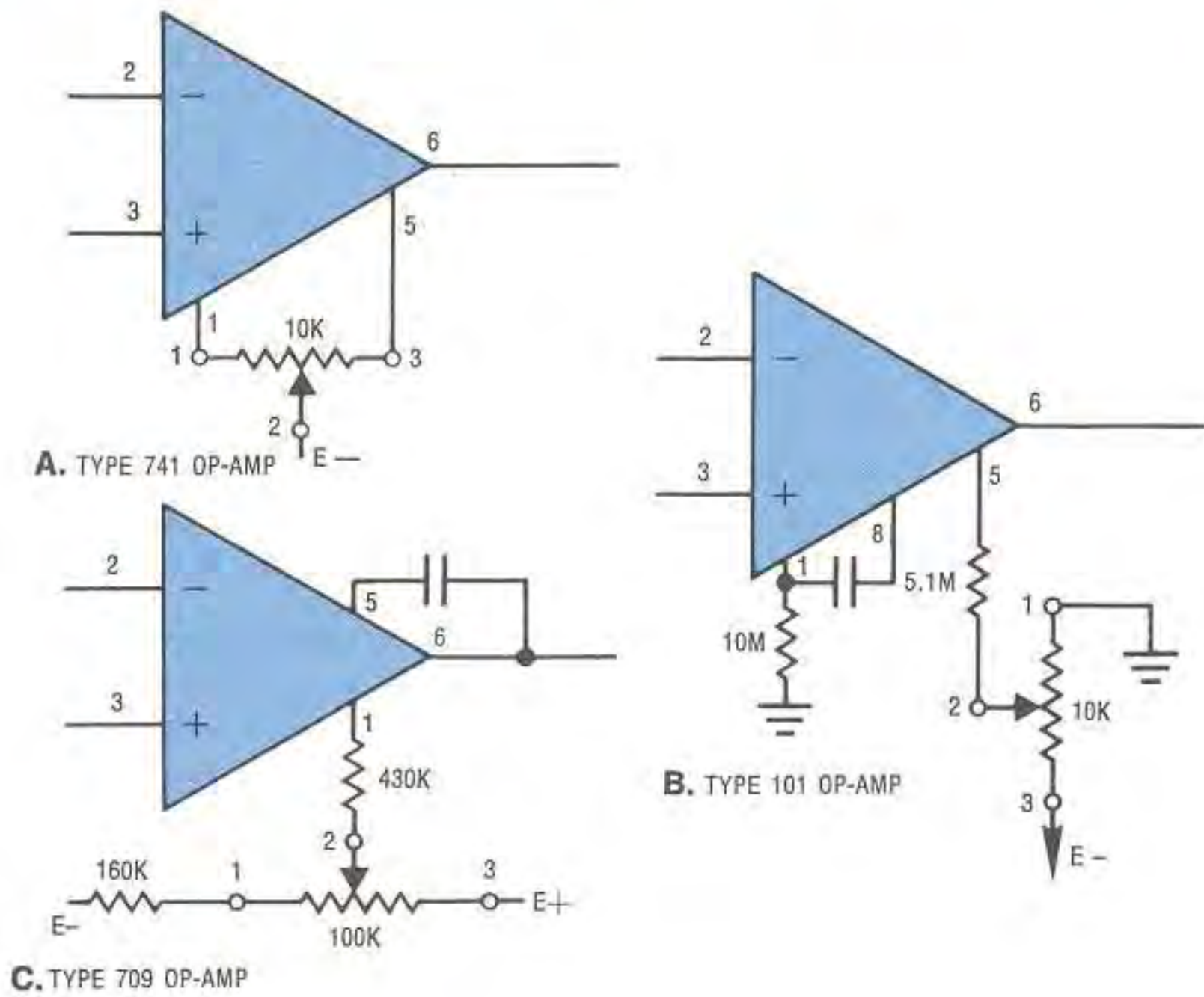

Fig. 4-6 Offset adjustment for operational amplifiers with internal balance access.



a more practical (lower) potentiometer value. Note that the actual value of the adjustment potentiometer is of little significance, since the loading is 5 megohms.

Offset voltage compensation can be accomplished on operational amplifiers that do not provide the internal access feature of those shown in Fig. 4-6. Four methods are presented in Fig. 4-7. Note that a different arrangement is required for each basic amplifier configuration.

For all of these offset adjustment methods the actual value of the trimmer from a performance standpoint is of minor significance. Lower values, however, will cause a greater power supply drain and yield somewhat poorer resolution with wirewound units. If a wirewound potentiometer is required, 10KΩ, which has a typical resolution of about 0.2%, is a practical total resistance value. Higher resistance values generally cost more. For cermet units 20K to 100K is the preferable choice.

In the offset compensation arrangements of Fig. 4-7, the compensation voltage is fed by a low output resistance voltage divider to prevent resistance level variations which might change the operating gain.

**Gain Adjustment.** Potentiometers are also useful in providing a means of adjusting the voltage gain of an operational amplifier circuit by modifying the feedback ratio.

Several gain adjustment arrangements for non-inverting amplifiers are shown in Fig. 4-8. In the configuration of Fig. 4-8A, the adjustment potentiometer is used to vary the value of R<sub>4</sub>. Operating voltage gain G<sub>E</sub> is given by:

$$G_E = 1 + \frac{R_4}{R_1}$$

which is much less than the open-loop gain of the basic operational amplifier.

The minimum gain is obtained when the potentiometer R<sub>3</sub> is adjusted to its minimum resistance. Maximum gain occurs when the TR of R<sub>3</sub> is adjusted into the feedback circuit or:

$$G_{E \text{ min}} = 1 + \frac{R_M + R_2}{R_1}$$

$$G_{E \text{ max}} = 1 + \frac{R_T + R_2}{R_1}$$

Although the presence of resistor R<sub>2</sub> is not

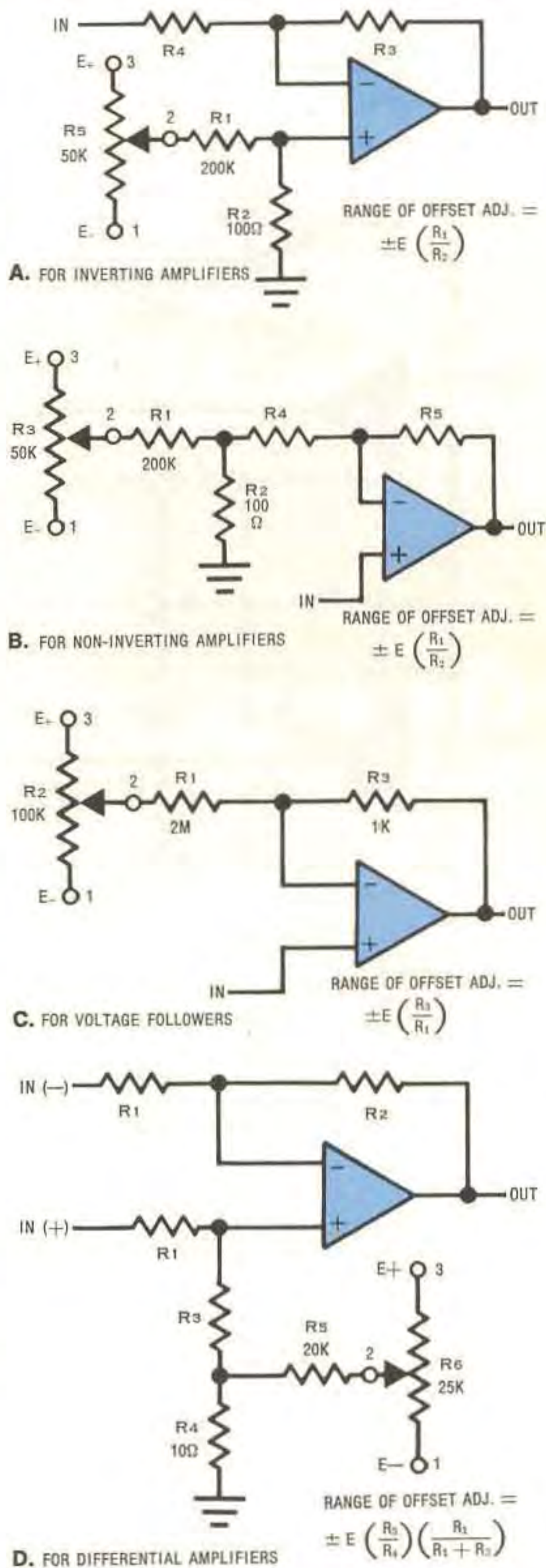
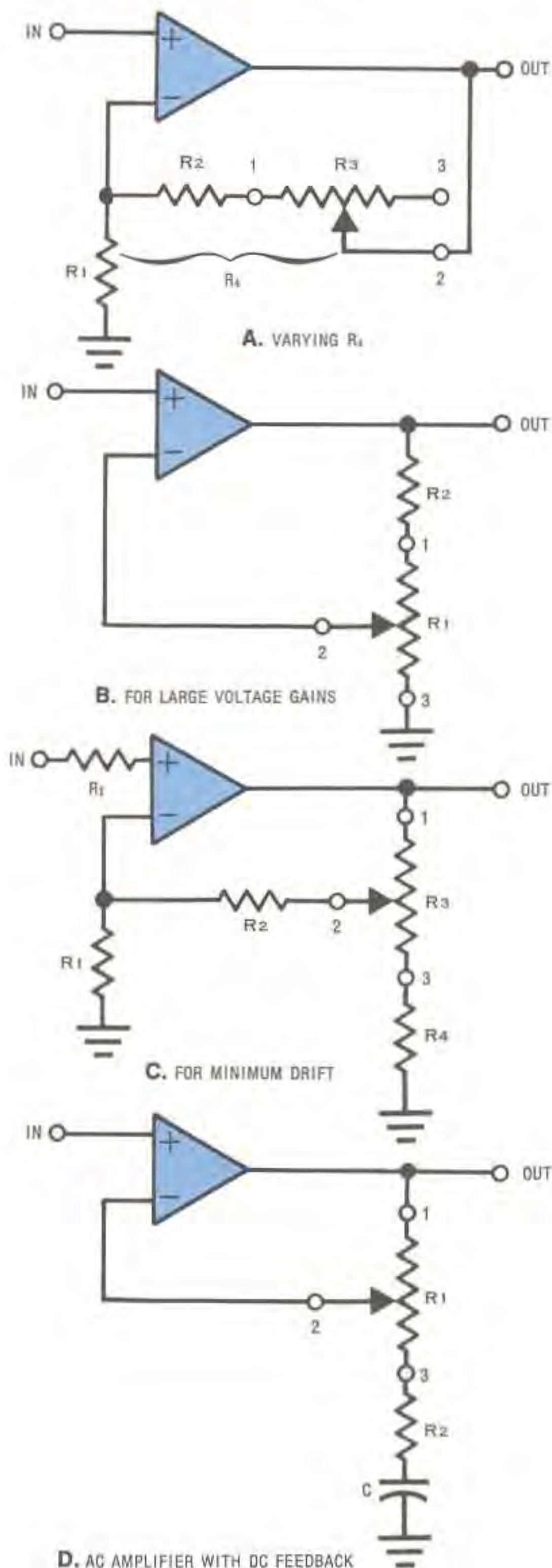

Fig. 4-7 Offset adjustment for various operational amplifier configurations





**Fig. 4-8** Gain adjustment for non-inverting amplifiers

absolutely necessary, it is advisable for several reasons. First, an absolute minimum gain is generally desired with a certain amount of gain increase possible. As in all adjustment arrangements, any excess in the adjustment range is wasted and results in reduced adjustability and some loss of stability.  $R_2$  effectively establishes the minimum voltage gain, the potentiometer's minimum resistance being negligible, and the adjustment range is provided by the variable resistance.

Where the necessary adjustment range is a small fraction of the overall gain,  $R_2$  results in some additional benefits. If  $R_3$  must be remote from the operational amplifier circuitry, the possible noise picked up by the potentiometer leads is reduced. Note that this is not true if the relative position of  $R_2$  and  $R_3$  are interchanged.

The circuit arrangement of Fig. 4-8B is particularly useful when voltage gains of very large magnitude are required. With the wiper of the adjustment potentiometer set at the ground end, the gain is equal to the open-loop gain of the basic amplifier. An additional fixed resistor could be placed in series with the ground end of the potentiometer element in order to limit the maximum gain to a lower value.

The configuration shown in Fig. 4-8C uses a voltage divider between the output of the adjustment potentiometer and the feedback input. This serves several purposes. First, it can reduce the required total resistance value of the potentiometer. For critical dc amplifier circuits it is necessary that the equivalent resistances seen by the two differential inputs be matched for minimum drift. The value of the input source resistance  $R_1$  might be  $10K\Omega$ , thus requiring the output resistance of the total feedback circuit to likewise be  $10K\Omega$ . Assuming a desired voltage gain of about  $1000 \pm 200$ , the values of  $R_2$  and  $R_3$  in Fig. 4-8A would be 8 and 4 megohms, respectively. A more practical value of potentiometer total resistance is certainly needed and is developed below.

Consider the arrangement given in Fig. 4-8C with  $R_1=10K\Omega$ ,  $R_2=8.06Meg\Omega$ ,  $R_3=10K\Omega$ , and  $R_4=20K\Omega$ . When the adjustment potentiometer is set to the terminal 1 end, the full output voltage is fed to  $R_2$  and the voltage gain is approximately 800, the desired minimum value. Then, when the potentiometer is set to the terminal 3 end, only 1.5 times the output voltage is applied to  $R_2$ . The resulting voltage gain will be three-halves the previous value or 1200, the desired maximum. The  $10K\Omega$  resistance for the adjustment potentiometer is much more practical than 4 megohms and the end result meets all of the desired requirements.

The voltage divider arrangement of Fig. 4-8C



also provides improved noise immunity if the potentiometer must be remotely located. The relative signal level is high at the location of the potentiometer and the resistance level is fairly low. Both of these factors will reduce noise pickup.

Fig. 4-8D illustrates a gain adjustment arrangement for an ac amplifier with 100% dc feedback. The impedance of capacitor C must be very low in comparison with R2.

Voltage gain adjustment configurations for inverting amplifiers are given in Fig. 4-9. The feedback signal is a current, unlike the non-inverting amplifiers of Fig. 4-8 which utilize a voltage feedback signal.

The basic arrangement of Fig. 4-9A has a voltage gain of:

$$G_R = \frac{R_4}{R_1}$$

R4 is again composed of a fixed value, which establishes the minimum gain, and an adjustment potentiometer which provides the desired adjustment range.

Where potentiometer resistance values for the circuit of Fig. 4-9A become unreasonable, the circuit arrangement of Fig. 4-9B provides benefits analogous to those realized in the arrangement of Fig. 4-8C discussed previously.

Fig. 4-9C illustrates a circuit capable of achieving a wide range of gain variation with practical values.

**Filters.** Operational amplifiers are frequently used in active filter circuits. Trimmers are used to adjust both the Q and the operating frequencies.

Fig. 4-10 illustrates one simple bandpass filter which has a variable Q (and gain) controlled by the adjustment potentiometer R2.

The center frequency of this filter may be changed (without affecting the Q) by varying C1 and C2 or R1 and R3.

Each of the frequency determining resistors may be replaced by a fixed resistor in series with a trimmer. Dual trimming potentiometers, which allow easy adjustment of both resistors simultaneously, are not readily available. This is because demand for them is low. Their cost is relatively high when compared with two separate potentiometers. When two separate trimming potentiometers are used they must be adjusted individually, varying each a little at a time, while trying to change each by an equal amount.

**Variable Capacitance.** Operational amplifiers may be used to multiply the effective values of either resistive or reactive elements. Fig. 4-11 illustrates one configuration which can be used

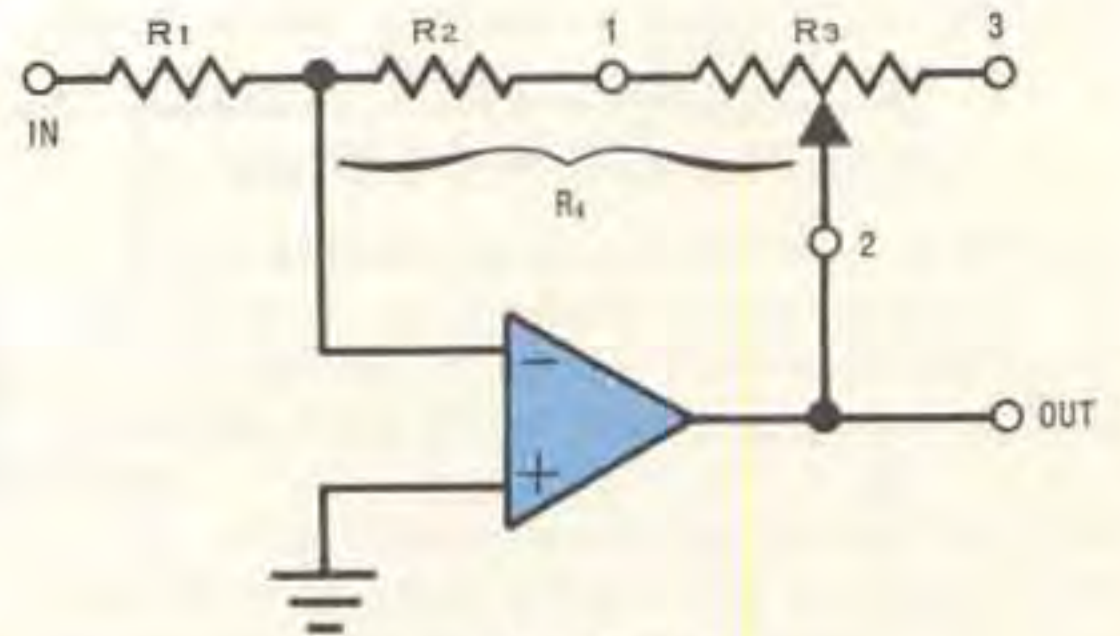

A. VARYING R4

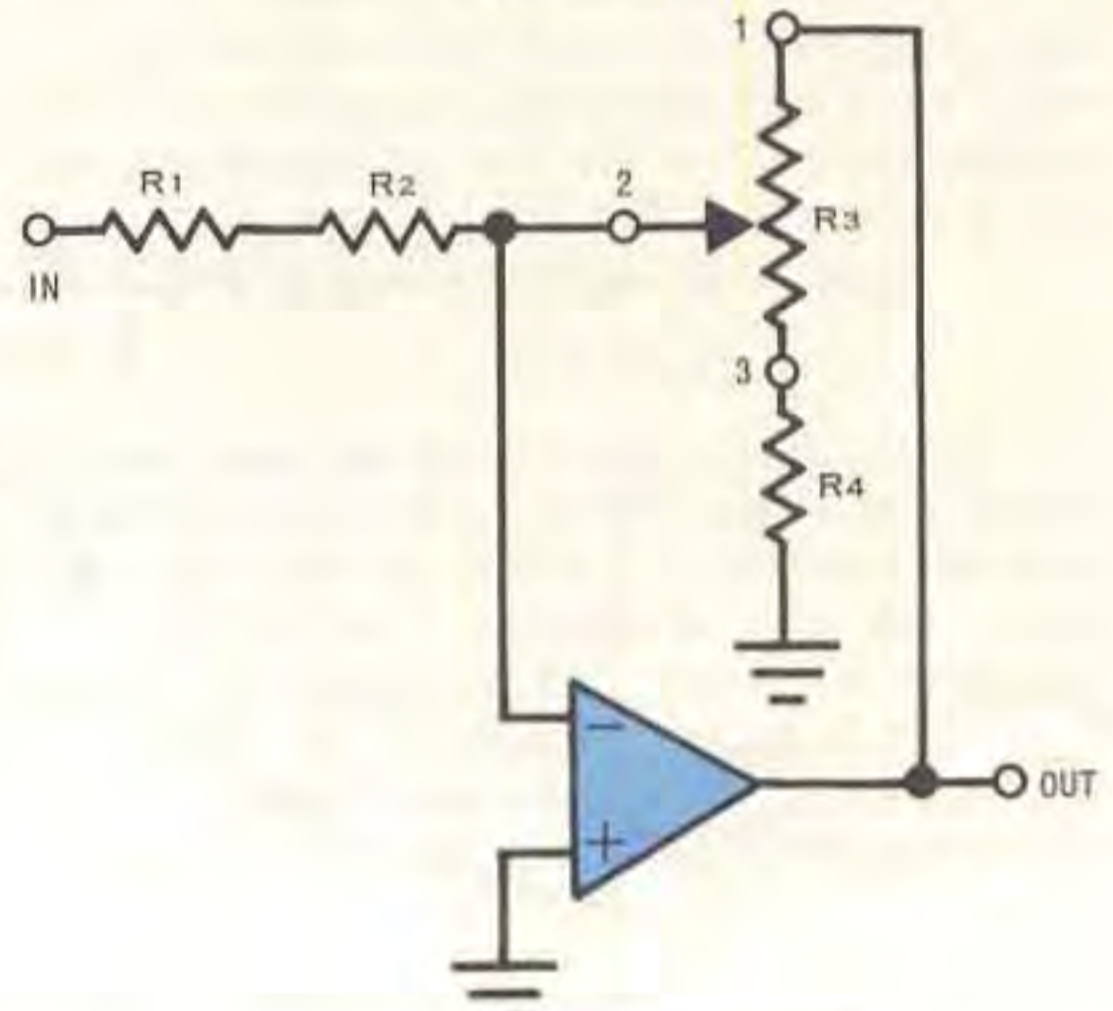

B. FOR MINIMUM DRIFT

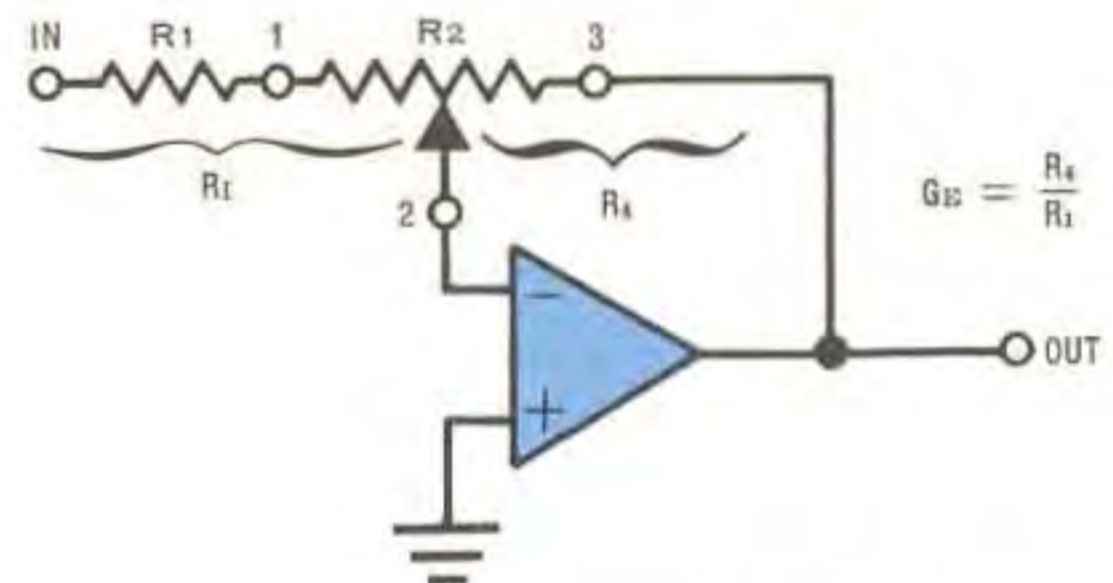

C. WIDE GAIN VARIANCE CAPABILITY

Fig. 4-9 Gain adjustment for inverting operational amplifiers

to develop an equivalent variable capacitor with a range from 0.1 to 1.0 microfarads using a fixed capacitor C1.

This application illustrates how a trimming potentiometer may be used to vary a parameter other than current or voltage ratio alone. R2 varies the relative currents fed from the outputs of the two operational amplifiers. This signal is fed to the inverting input of the second unit and thereby adjusts the amount of multiplication which occurs.



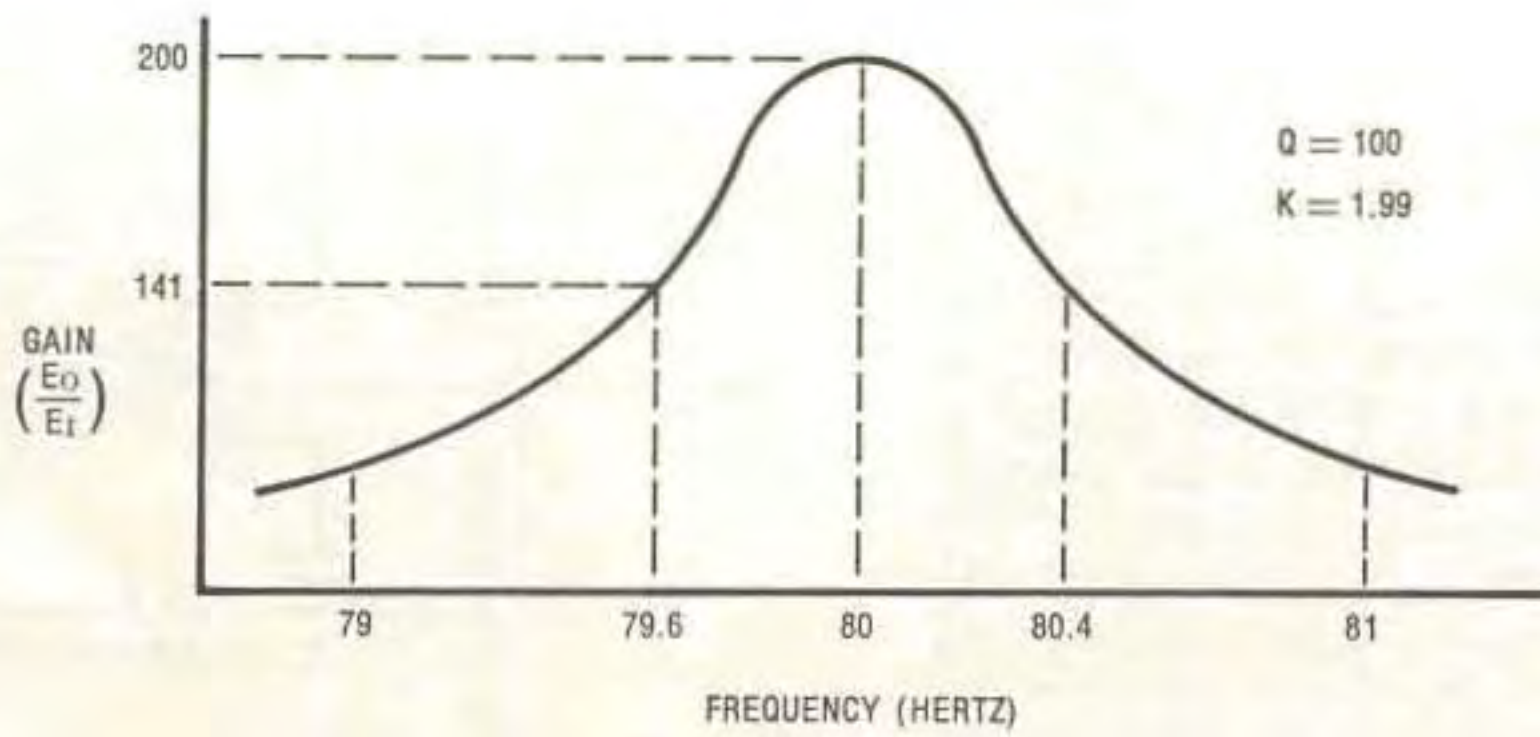
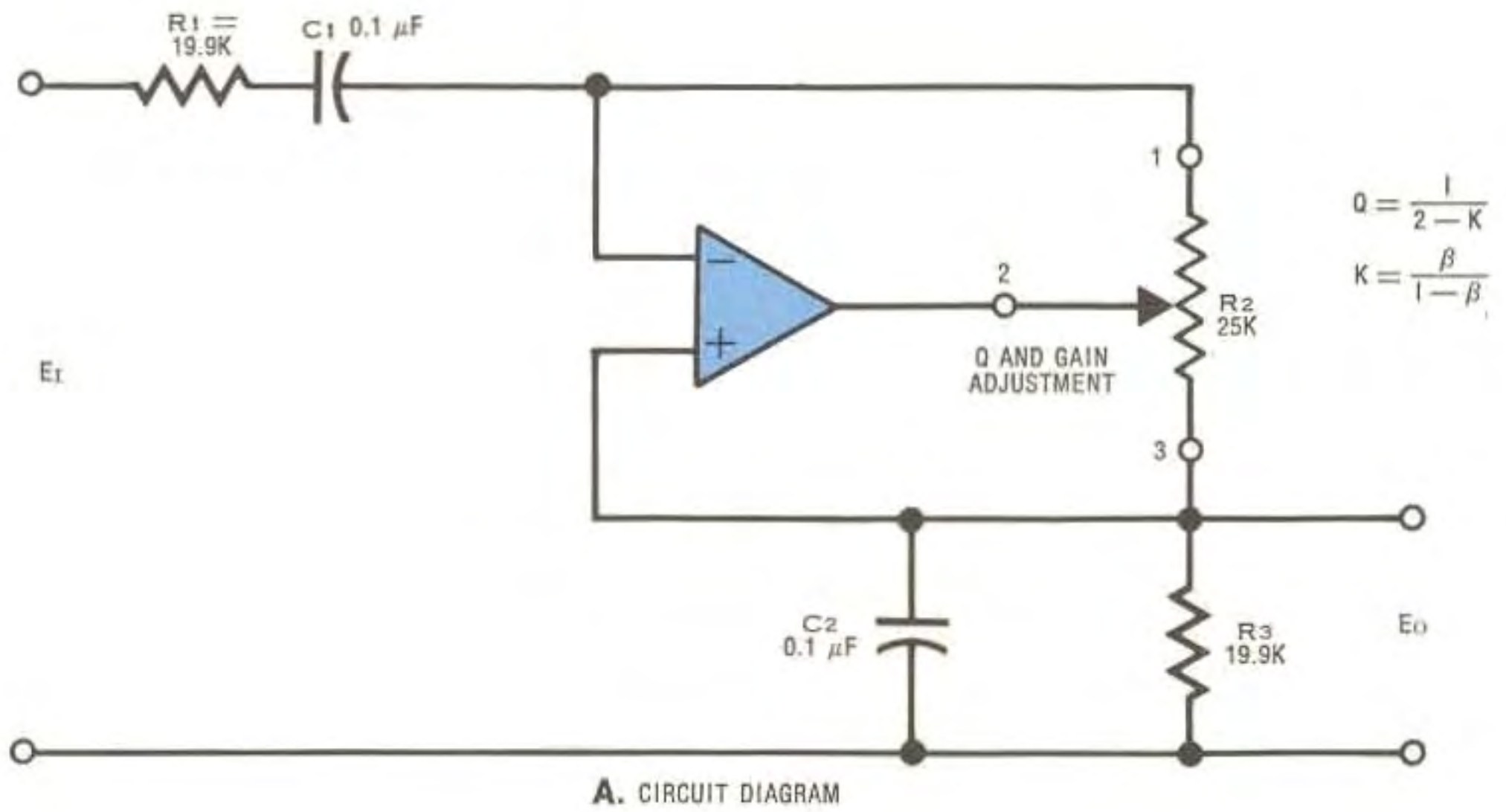

**Fig. 4-10** Active band pass filter with variable Q

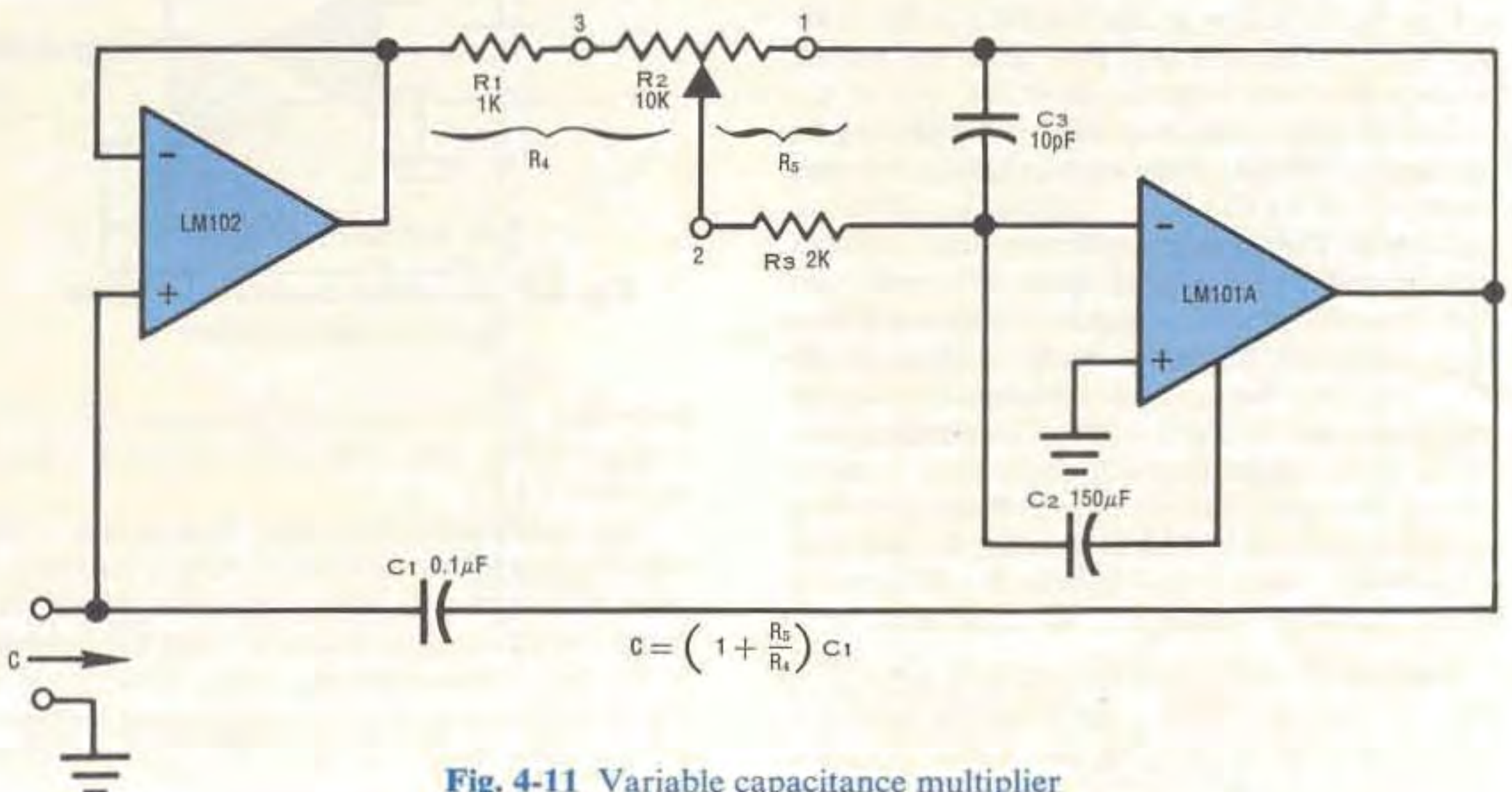



Trimming potentiometers and IC operational amplifiers make good teammates. The wise designer will make full use of both of them.

## DIGITAL CIRCUITS

Trimmers may be used in digital applications to provide adjustment for common characteristics such as time delay, clock frequency, and threshold levels. They are available in dual in-line packages (DIP). In addition to conventional solder mounting they may be inserted in IC sockets, thus permitting popular digital system wiring techniques to be used.

When using potentiometers in digital circuits, where fast rise or fall times are required, choose a cermet type. A wirewound device may exhibit a significant inductance and can result in undesirable behavior.

A few typical applications are presented to illustrate the possibilities.

**Monostable Timing.** One of the most common digital applications of adjustment potentiometers is the control of time delay in an integrated circuit monostable. Fig. 4-12 illustrates one of the commonly used monostable types.

The amount of time delay is directly propor-

tional to the product of capacitor  $C$  and the sum of  $R_2$  and  $R_3$  or:

$$\text{Time Delay} = C[R_2 + R_3] = R_4 C$$

$R_2$  serves to limit the minimum value of the timing resistance as required for the given IC.  $R_2$  can be selected to cause the potentiometer to adjust the time delay around a given nominal value.

Fig. 4-13 illustrates the circuit for another type of monostable using a 555 IC timer. Once again, a trimmer is used to vary the RC time constant to control the time delay interval.

The additional circuitry, consisting of resistor  $R_3$  and potentiometer  $R_4$ , provides a calibration adjustment where the timing resistor may be a precision potentiometer with a dial. The nominal delay time is given by:

$$t_1 = 1.1R_5C$$

Some variation exists from one IC to the next causing the factor 1.1 to vary over a small range. In order to make several circuits yield the same time delay,  $R_4$  is adjusted to vary the voltage appearing at pin 5. This voltage is nominally two-thirds of the supply voltage  $E+$ . Adjustment of  $R_4$  will compensate for timing capacitor tolerance variations as well as IC differences.

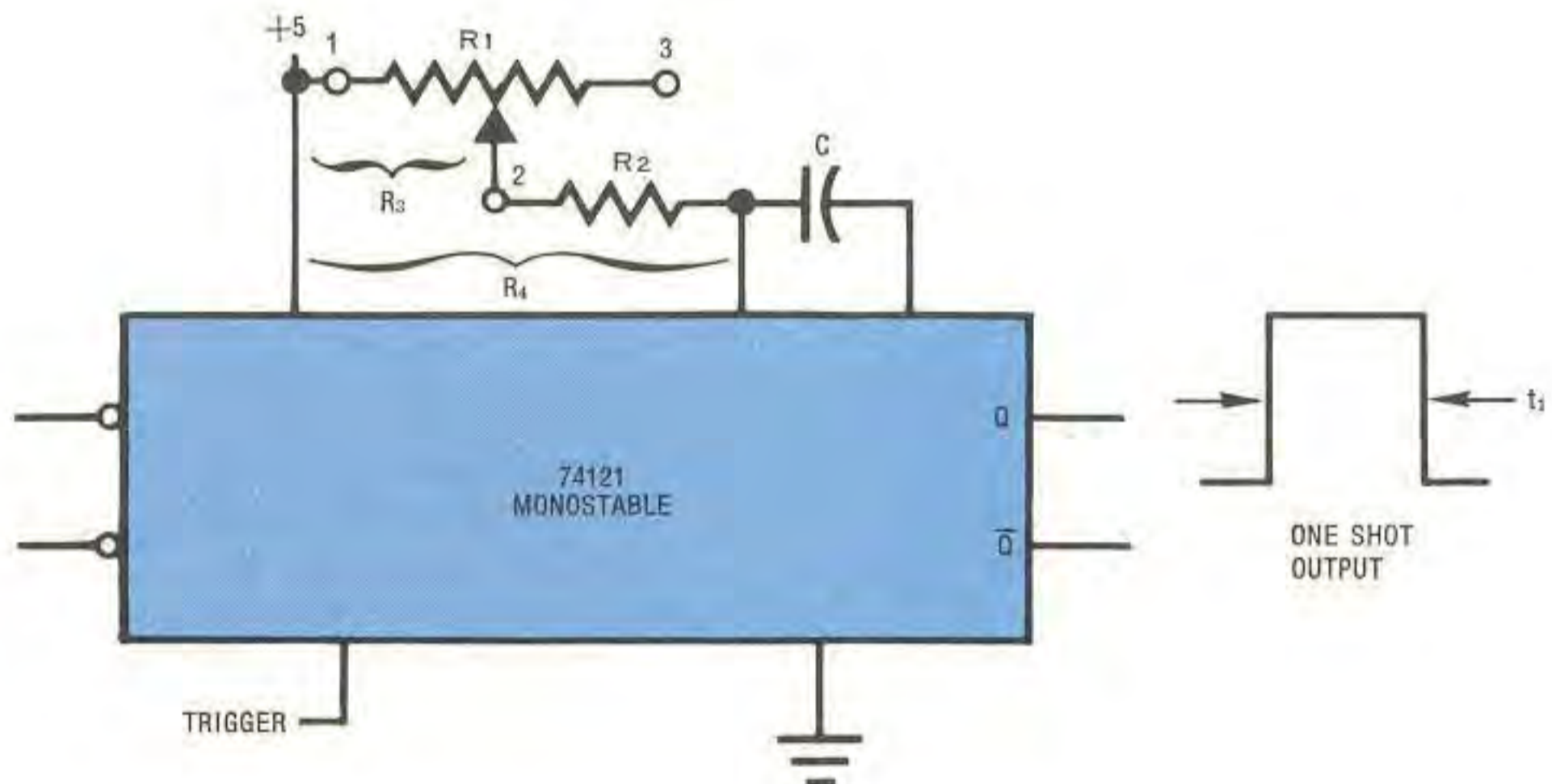

**Fig. 4-12** A trimming potentiometer is frequently used in digital circuits to adjust timing of monostable



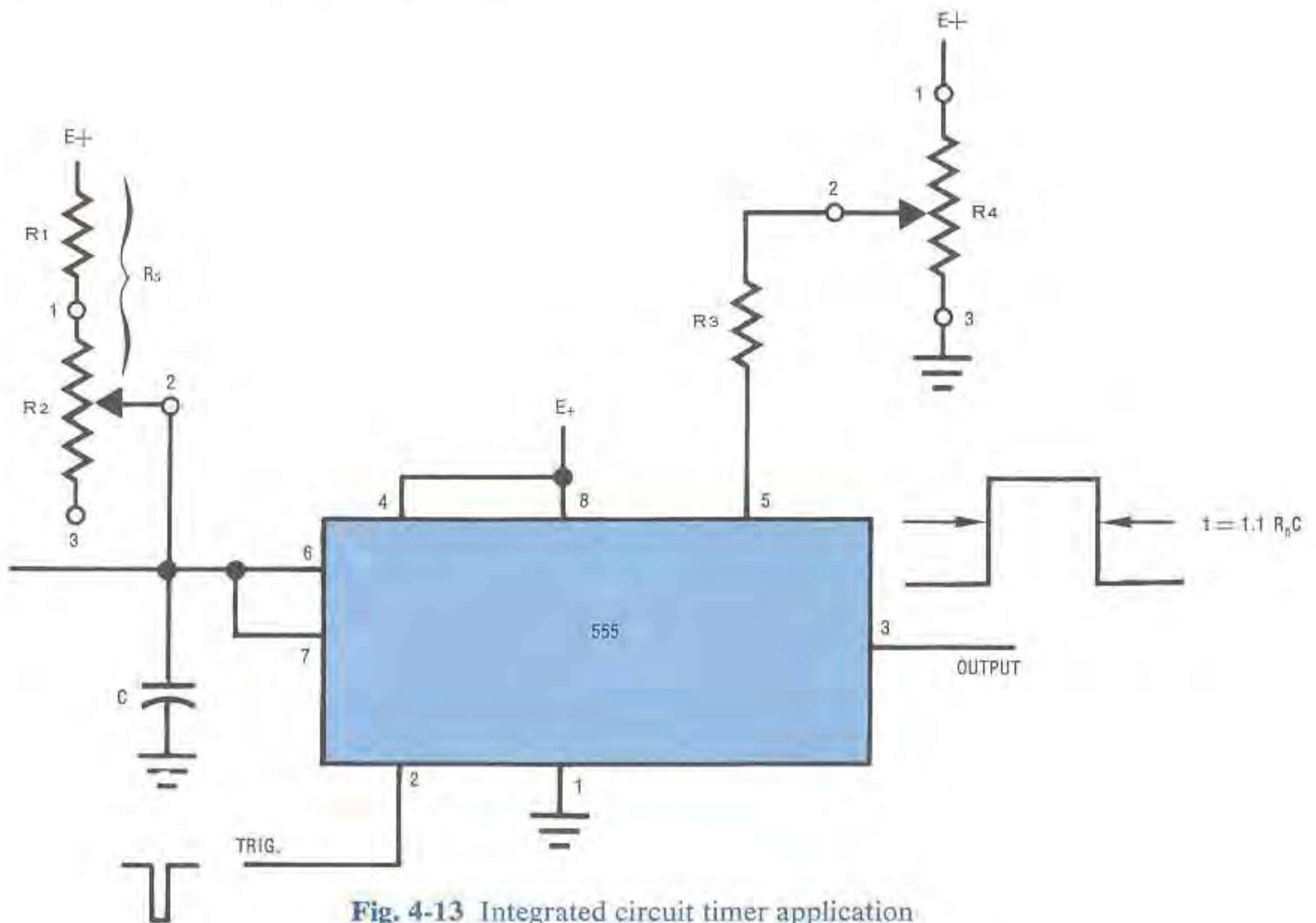

Fig. 4-13 Integrated circuit timer application

**Clock Generator.** Where an accurately controlled clock is not required, a single monostable IC may be used in a somewhat non-standard mode to yield an astable clock generator as shown in Fig 4-14.

The basic width of the output pulse is relatively constant and depends upon delays within the IC. The interval between output pulses, and hence the clock frequency, is controlled by the RC time constant which is easily adjusted by the trimmer.

**Photocell Sensitivity.** All photocells, whether resistive or voltaic, exhibit some variation in sensitivity from one unit to the next. Trimming potentiometers may be used to adjust the sensitivity of each cell to a uniform value or compensate for other variations in the optical system. Fig. 4-15 shows the circuit diagram for the photocell amplifier of one channel in a paper tape reader.

With no light falling on the cell (no hole in the tape) the photocell conducts little current. Transistor Q1 is turned on and Q2 is off. When light strikes the photocell through a hole in the paper tape the photocell conducts enough bias current away from the base of Q1 to turn Q2 off. This turns Q2 on and the output is pulled to ground. The feedback path through R6 produces a slight

amount of regeneration.

The trimmer R1 controls the base bias current to Q1 and hence the amount of light required on the photocell to activate the circuit. Each channel has its own sensitivity adjustment to compensate for differences in individual photocells, minor position errors, and other circuit variations.

Resistive photocells are frequently used in a bridge circuit where the cell is in one branch and a trimmer is located in the opposite branch to adjust the balance at a given light level.

**Data Conversion.** Analog to digital and digital to analog converters are common system interface functions. Trimming potentiometers are necessary to provide adjustment of offset errors and scaling values.

Fig. 4-16 illustrates the arrangement for a typical analog to digital module. One potentiometer R2 is necessary to adjust the input offset voltage such that digital zero will result from zero input voltage. Another potentiometer R1 is used to control the sensitivity such that all digital outputs will be "1" when the desired full-scale voltage is applied to the analog input.

In some high precision analog to digital and digital to analog conversion systems, individual adjustment may be provided for several of the



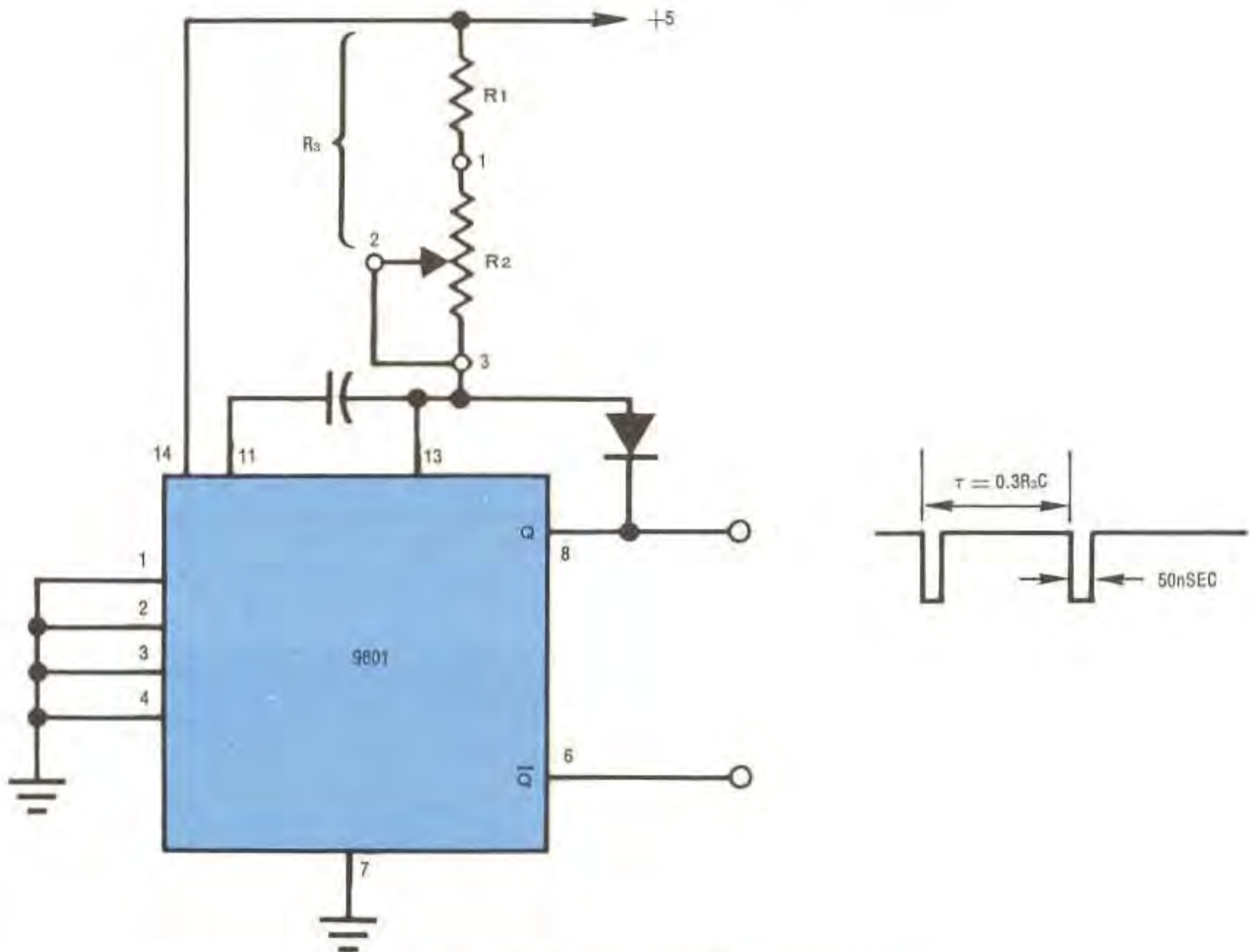

Fig. 4-14 Clock circuit uses IC monostable.

high order bits.

**Digital Magnetic Tape Deck.** In the typical digital tape deck, which usually has 9 tracks, there are 26 adjustment potentiometers. They are required to provide the degree of uniformity needed, from one deck to the next, for tape interchangeability. This is not only a cost-effective application but also an essential one.

One potentiometer adjusts the logic power supply voltage and another controls the photo-cell sensitivity for the beginning and end of tape marker detectors.

Individual gain controls are provided for each of the nine read amplifier channels. This compensates for possible variations in read-head sensitivity as well as component tolerance differences in the amplifiers.

Another adjustment potentiometer is used to vary the timing in a read strobe delay monostable, while nine more potentiometers are used to individually adjust the write deskew monostable circuits for each track.

The remaining potentiometers are used for adjustment of the capstan servo system and are critical in assuring uniformity from one tape

deck to the next. One adjusts for capstan servo offset while two more allow precise setting of the forward and reserve tape speed. Finally, trimming potentiometers permit adjustment of the forward and reverse stop ramps.

## INSTRUMENTS

Trimming potentiometers play an important part in the electronic instrument field. They assist in making economical assembly and checkout possible as well as facilitating easy calibration in day to day use. They also provide adjustment for recalibration when repairs require the replacement of a critical component or where normal aging of components has caused a loss in accuracy.

Applications for electronic instruments are ever widening in scope and include such diverse fields as communications, computer, medical, manufacturing and process control and automotive performance analysis. Examples of trimmer applications from some of these fields are the subject of the following paragraphs.



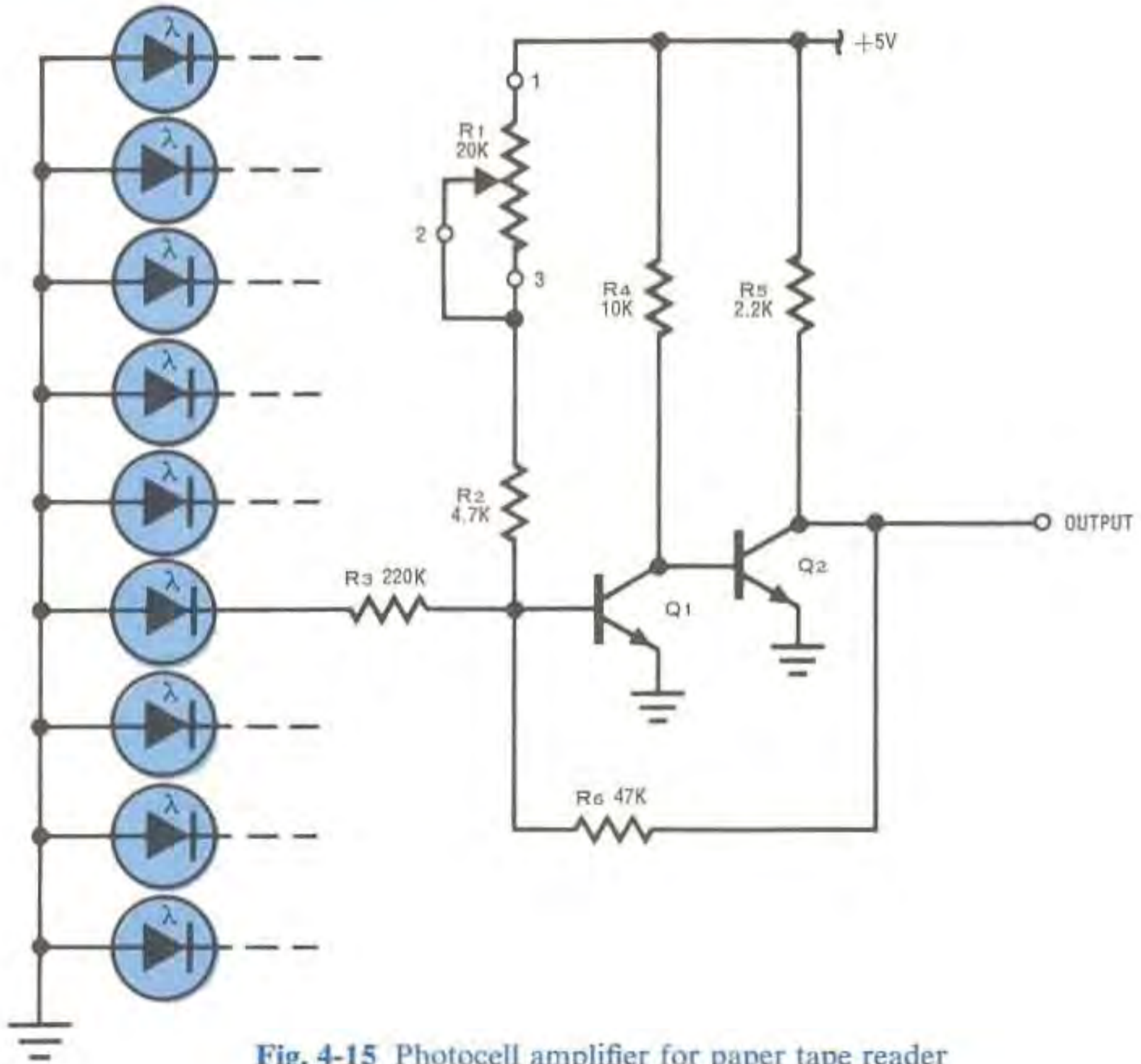

Fig. 4-15 Photocell amplifier for paper tape reader

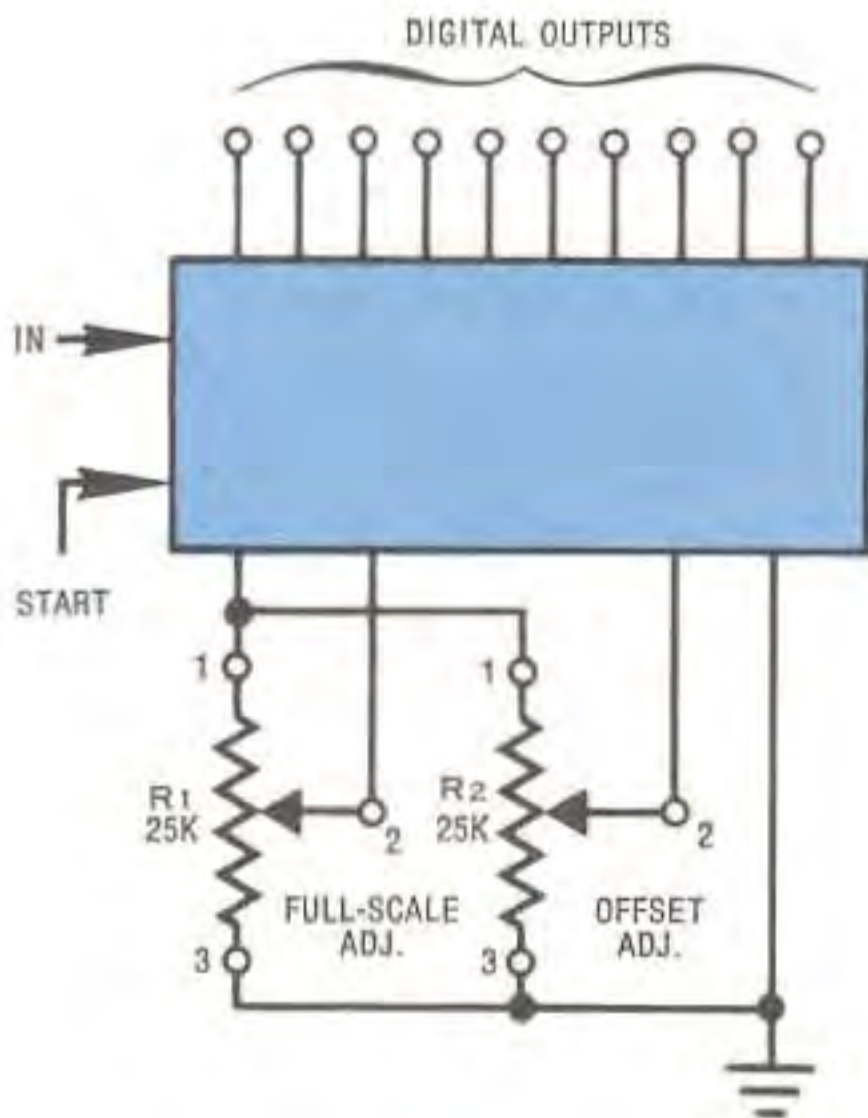

Fig. 4-16 Analog to digital converter modules use potentiometers for offset and full-scale adjustment

**Digital Voltmeters.** Adjustment potentiometers are used in digital voltmeters to provide compensation for component tolerance variations and permit proper calibration.

Typical applications include power supply control, both for the operating supply and the precision reference voltage, zero adjustment, amplifier gain control, and ramp speed adjustment. Separate calibration adjustments are often provided for each range, especially if the instrument includes a preamplifier to allow low-level measurement.

**Generators.** Signal generators require adjustment of oscillators, timing circuits, trigger circuits, linearity controls, and duty cycles. Where a precision control dial is used on the front panel, a trimmer is often used to adjust for proper calibration.

**Oscilloscopes.** Precision instrumentation oscilloscopes rely on adjustment potentiometers for control of their power supplies, amplifiers, timing and sweep circuits, and triggering circuits.

In some cases, access to some of the potentiometer trimmers is provided through small holes



in the front panel. While adjustment may not be needed often it may be easily performed when necessary.

**Portable Electronic Thermometer.** Fig. 4-17 shows one of the major advancements made in the medical instrumentation field in recent years. The electronic thermometer offers significant improvements in body temperature measurement. It is safer, easier to use, faster and provides greater accuracy than the standard mercury thermometer.

Inside the instrument case, an adjustment potentiometer is used to balance a bridge circuit which compensates for component and probe tolerances. In this application, a single turn, low cost, cermet device provides a cost effective alternative to selecting fixed resistors during construction. The potentiometer reduces assembly costs and simplifies calibration and maintenance procedures.

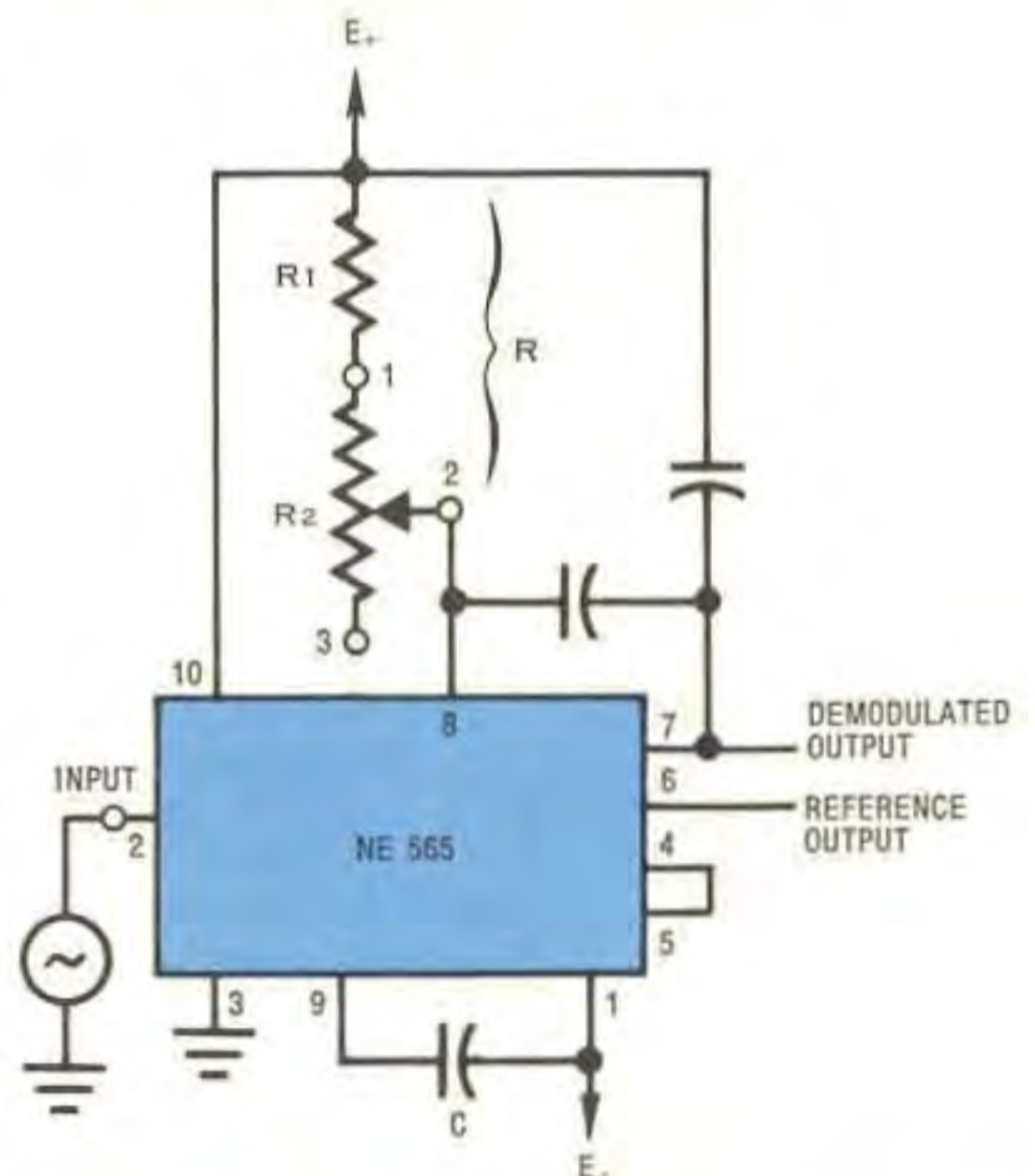

**Fig. 4-17** The electronic thermometer is the first major improvement in the fever thermometer in over 100 years. (AMI Medical Electronics, Div. of LMC Data, Inc.)

## MISCELLANEOUS APPLICATIONS

There are many additional applications where trimming potentiometers are useful. A few are briefly outlined below.

**Phase Locked Loops.** Phase locked loops consist of a voltage controlled oscillator, a phase detector, and a low pass filter connected in a servo system arrangement. Adjustment potentiometers are often used to control the free-run frequency of the internal oscillator in the manner shown in Fig. 4-18.



**Fig. 4-18** Trimming potentiometers adjusts free-run frequency in a phase locked loop FM demodulator

Potentiometers might also be used to set the levels of various threshold detectors used in conjunction with phase locked loop circuits.

**Linearity Optimization.** In applications where a precise conformity between a precision potentiometer function and relative wiper travel is required, it is common to specify a potentiometer with an absolute linearity specification. It is possible in many cases to save money and possible delivery delay by using a lower cost precision potentiometer purchased to an independent linearity specification; then using trimmers to optimize the operating linearity in your application.



Fig. 4-19 illustrates this cost-effective circuit arrangement. In Chapter 2, the basic deficiency in an independent linearity specification, as compared with absolute linearity, was shown to be a lack of control for the intercept and slope of the best straight line reference function.

Trimmer R1 in Fig. 4-19 acts primarily to control the slope of the transfer function. It is necessary that the input voltage  $E_1$  be slightly larger than the maximum full-scale output voltage required.

The second trimmer R3 permits adjustment of the effective intercept point. An index point of some kind is necessary. For this application, an index point near the low end will be best for proper adjustment of R3.

There is a certain amount of interaction between the two adjustments, so it may be necessary to repeat the calibration procedure one or more times. When the adjustment is completed, the performance obtained will be identical to the performance of a precision potentiometer purchased to an absolute linearity specification. The circuit of Fig. 4-19 provides added flexibility to compensate for minor errors in the dial or linkage controlling the wiper travel position.

**Nonlinear Networks.** Trimmer potentiometers can be used with VR (voltage reference)

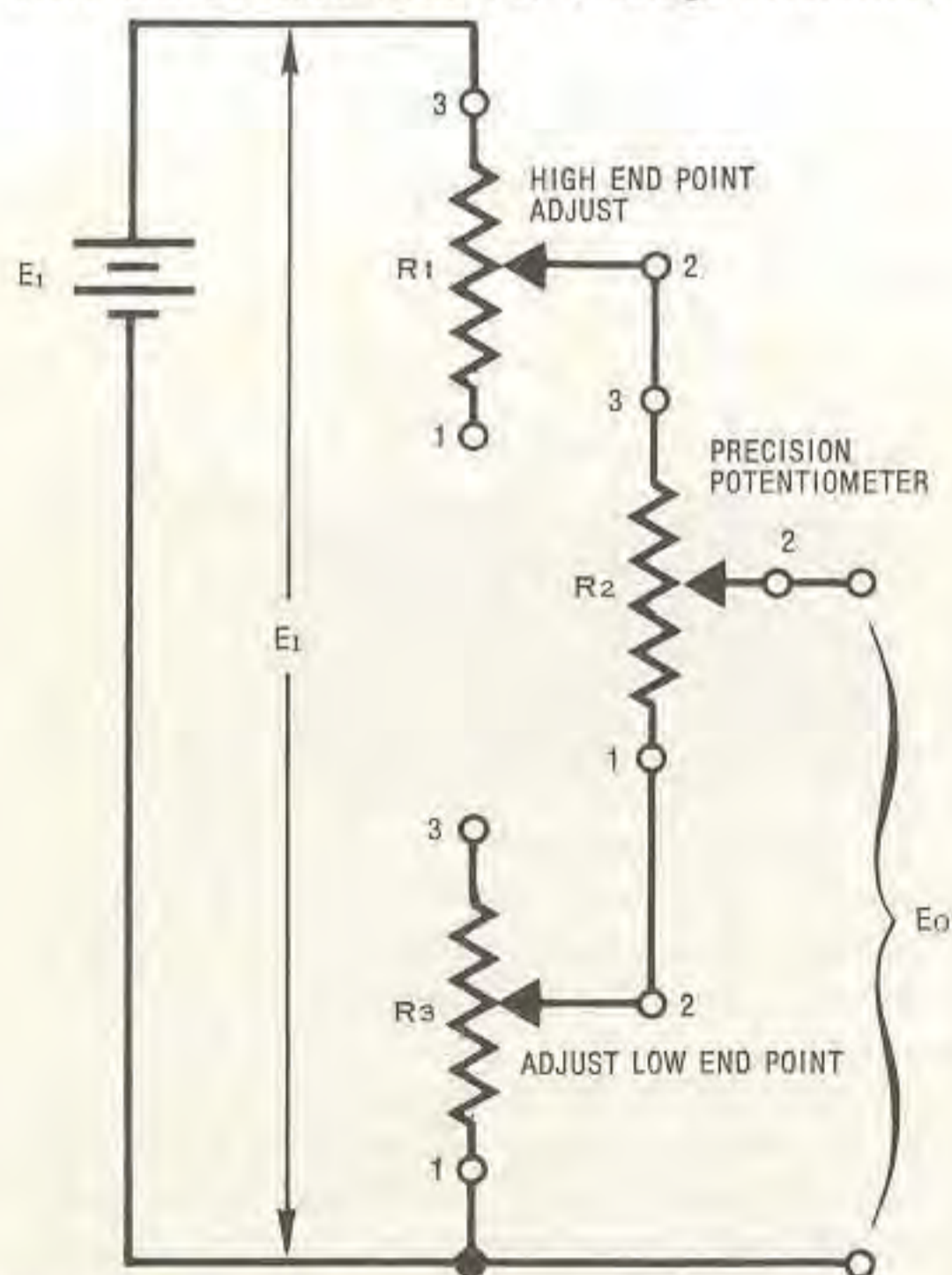

**Fig. 4-19** Two trimming potentiometers may be used to optimize linearity error in a precision potentiometer

diodes in the manner shown in Fig. 4-20 to produce a nonlinear resistance network. The voltage breakpoints are set by the breakdown voltages of the VR diodes, while the slope of the incremental resistance is adjusted by the trimmers.

Since all the lower voltage branches will affect the higher ones, the adjustment procedure should begin with R1 and proceed in order through R4.

Replacing the VR diodes with clamping diodes and variable voltage sources, results in additional flexibility over the shape of the characteristic curve.

**RF Tuning.** Usually a trimmer would not be considered for adjustment of an RF tuned circuit. There is a tuned circuit, which may prove to be cost-effective, that *does* use an adjustment potentiometer. In this design, which is becoming increasingly popular, particularly in TV receivers, a variable capacitance diode (varactor) tunes the RF circuit. The required tuning capacitance is achieved by adjusting the voltage applied to the diode with a trimmer.

Fig. 4-21 illustrates this simple arrangement. The dc bias control circuit may be located at a remote point. This method is also very useful when the circuit to be tuned is in an inaccessible location, such as within a temperature-controlled oven.

**Custom designs.** Applications of potentiometers chosen from manufacturers standard product line will usually produce the optimum in electrical and economical design. However, the circuit designer is not limited to these standard devices. Occasionally, electrical, mechanical or environmental application requirements will demand a variable resistance device of unique design. The following paragraphs describe a few of the components created by potentiometer manufacturers to meet the custom application demands of the electronic industry.

The potentiometer shown in Fig. 4-22 is a low resistance ( $<1\Omega$ ), high power (25 watts) rheostat. It is used in the regulator of an AC/DC converter in a computer system. It functions as a current control through parallel power semiconductor devices that carry load currents to the central processor unit. In this application, the custom designed rheostat proved to be the most economical alternative due to the low cost of field maintenance as compared with other methods.

When the circuit function requires many variable and fixed resistors to accomplish a task, the most cost effective approach could be the multi-potentiometer network. Fig. 4-23 illustrates a network that was custom designed for multi-



channel varactor tuning of a television receiver. The advantages of this thick-film module are: 1) less space required for packaging, 2) fewer parts to stock, inventory and install in the system, 3) the lowest cost per variable function in high volume production quantities.

A very ingenious method of adjusting the electrical output of an implanted heart pacer from outside a patient's body, without the need for surgery or through-the-skin leads has recently been developed.

The technique utilizes a tiny magnetically driven mechanism inside the pacemaker module that can be made to rotate (adjust) by spinning a precisely configured and positioned magnetic field — outside the body, directly over the implanted pacemaker.

At the core of the mechanism is a single-turn cermet adjustment potentiometer. See Fig. 4-24. The potentiometer/mechanism is installed in a tiny, magnetically-transparent metal can embedment. The potentiometer adjustment slot is linked to a small clock-like precision gear train. At the input end of the gear train is a miniature wheel with two rod magnets installed parallel and on either side of the wheel centerline. The gear ratios and the fine balance of the mechanism are such that very little torque is required to spin the mechanism. The relationship of gear turns to movement of the potentiometer element wiper enables extremely precise adjustments. This also protects the patient from any detrimental effects due to movement of the mechanism as a result of vibration, inertia or stray magnetic energy.

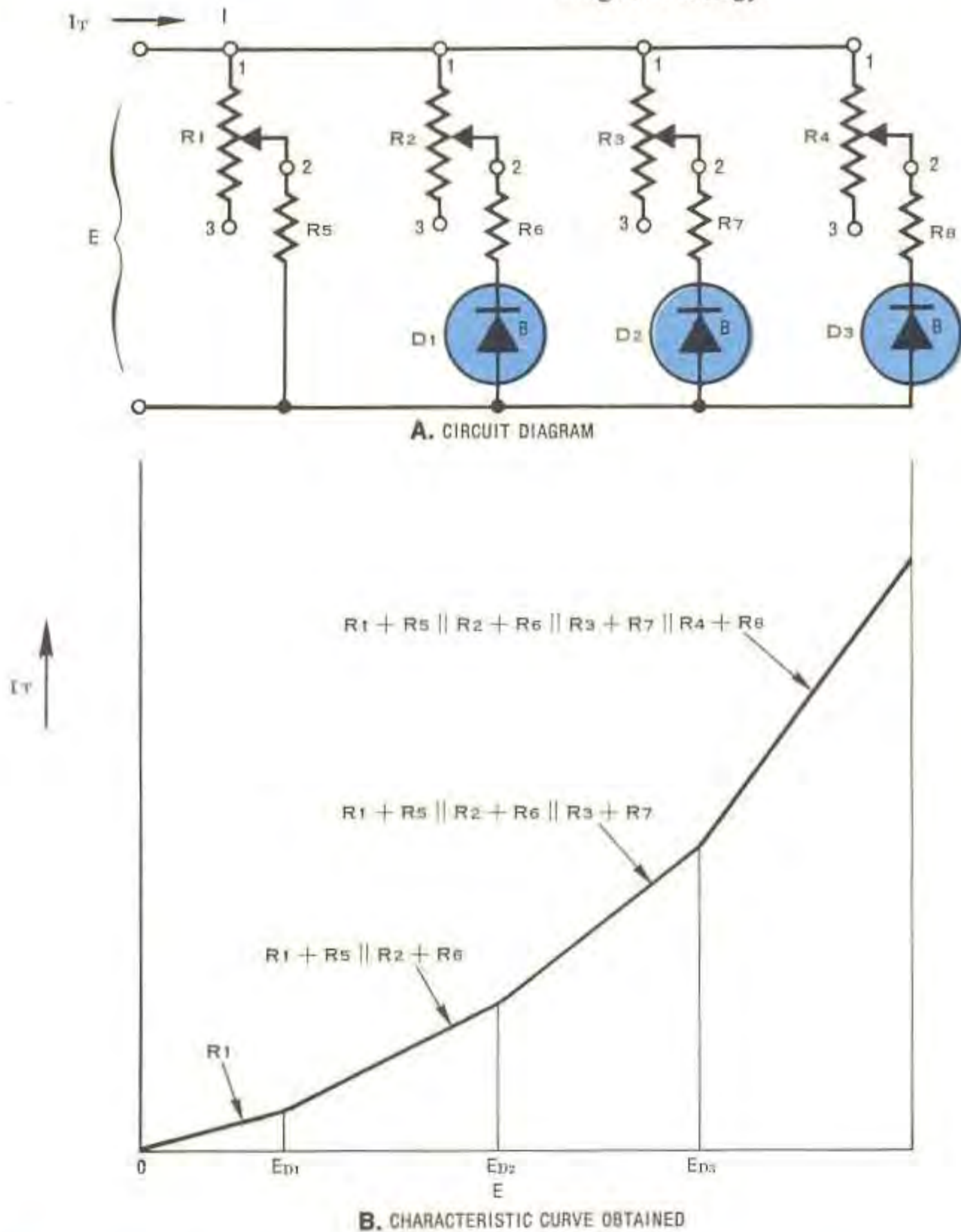

Fig. 4-20 A nonlinear resistance network synthesized with VR diodes and trimmer potentiometers



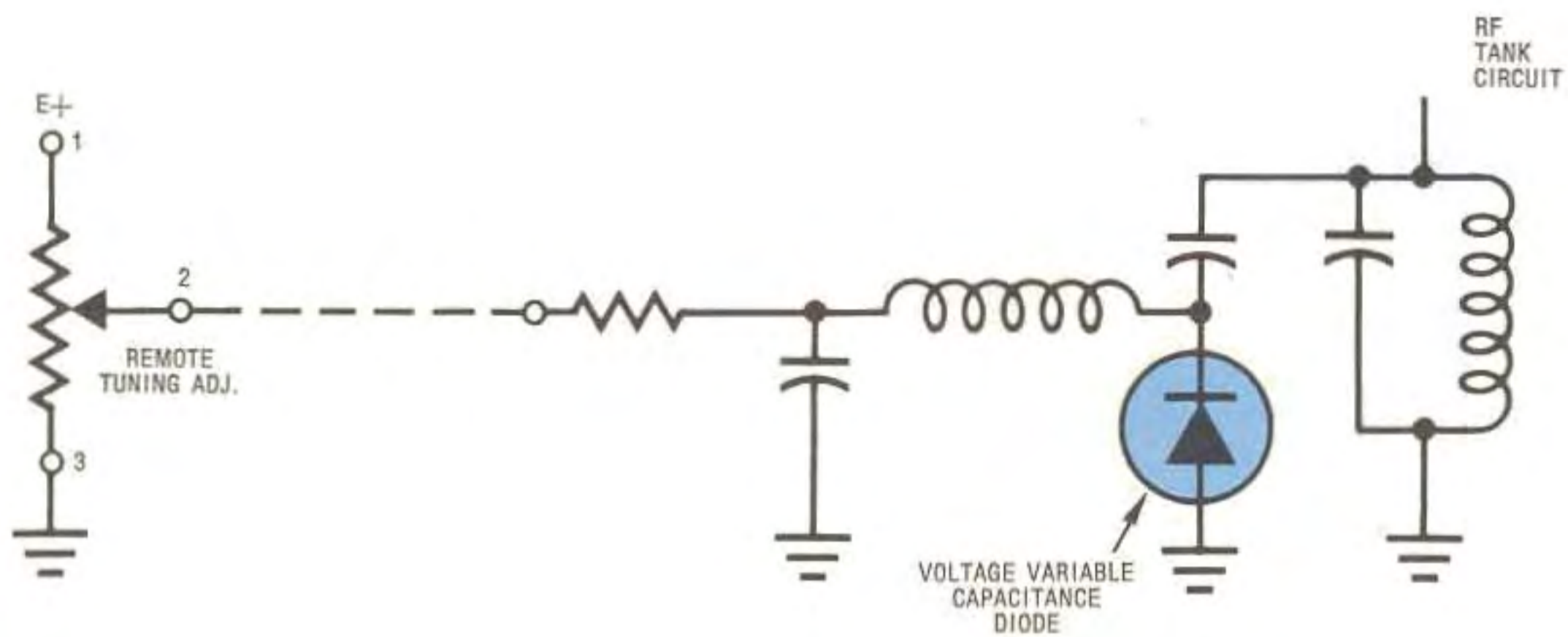

Fig. 4-21 Trimming potentiometers may be used to perform RF tuning

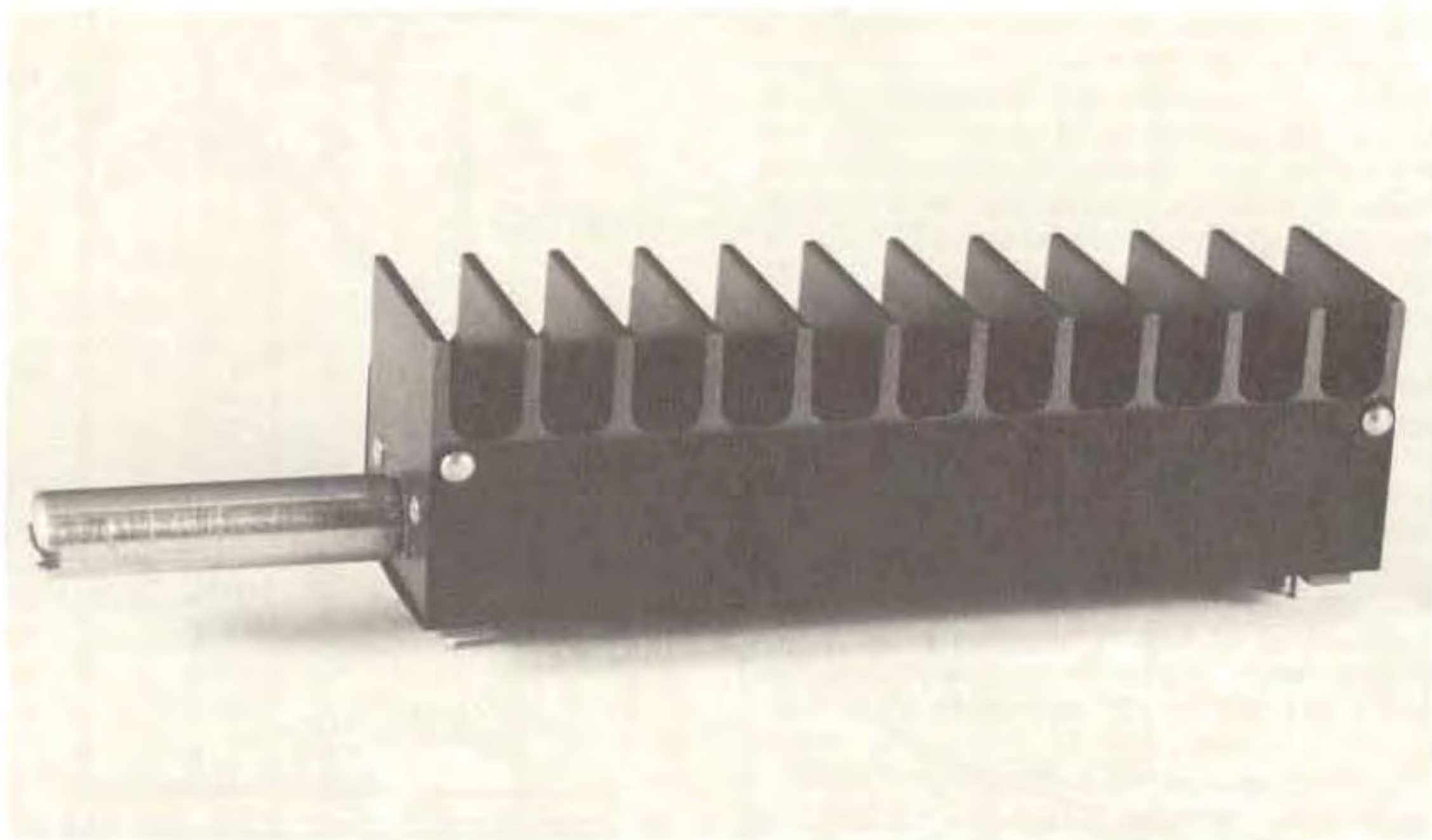

Fig. 4-22 A high power, low resistance custom designed rheostat



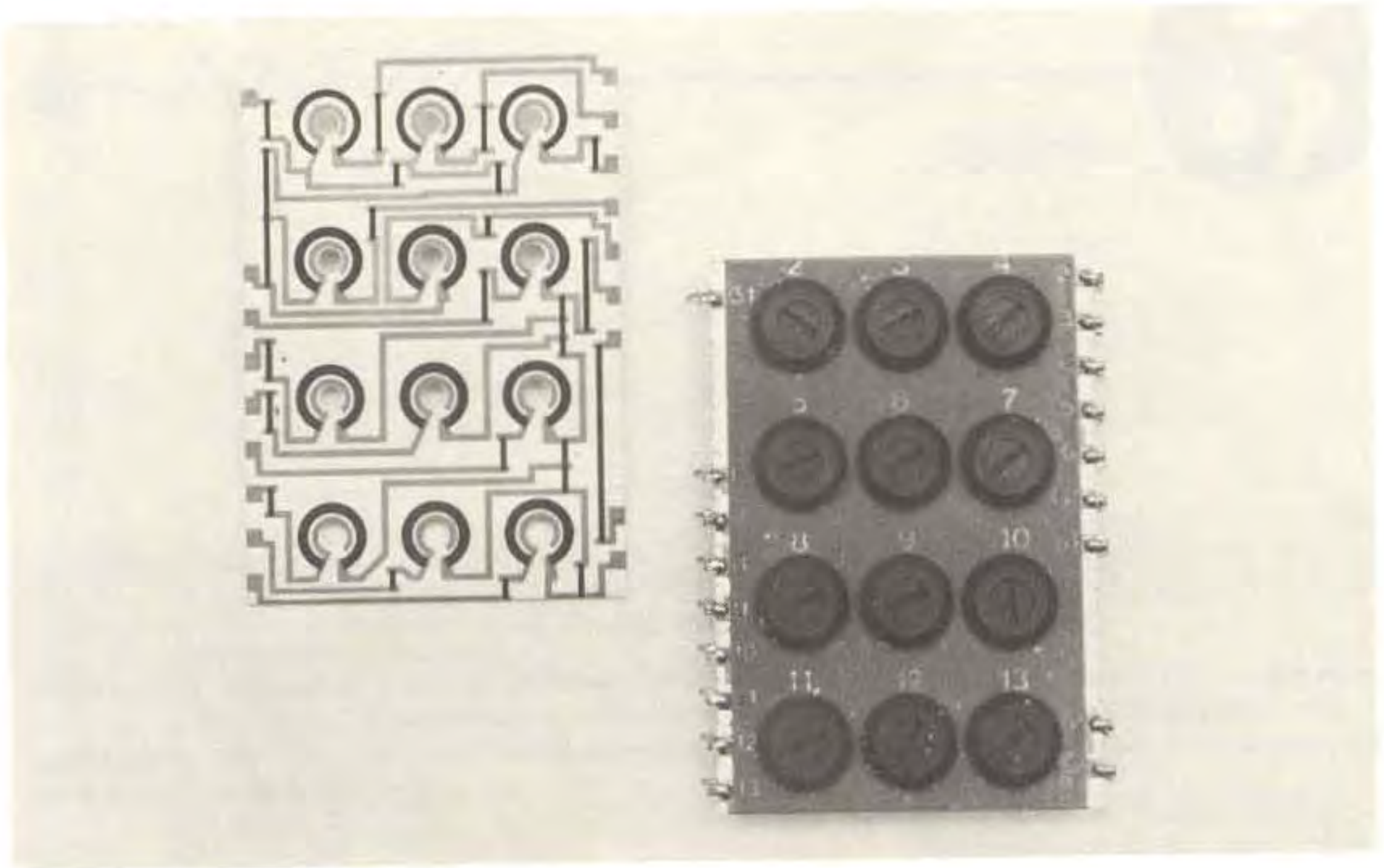

Fig. 4-23 A custom designed multi-potentiometer network



Fig. 4-24 A potentiometer provides adjustment of electrical output of implanted heart pacer



# APPLICATION AS A CONTROL DEVICE



## Chapter

# 5

### *Double Control Unit*

*Electrad, Inc. announces a Model B Super Tonatrol which is particularly adapted for use by manufacturers on account of its arrangement whereby if desired, two completely isolated circuits may be controlled by one shaft. The contact is a pure silver multiple type which floats over the resistance element with amazing smoothness. . .*

*From the New Products section of Electronics Magazine, April 1930.*

## INTRODUCTION

Potentiometers can provide a means for frequent adjustment of an electrical circuit or system where operator control is desired. Chapter 4 presented applications requiring only an initial or occasional adjustment. These are usually best served by a trimmer type of potentiometer.

In this chapter, the focus is on applications in which more frequent and convenient adjustment is anticipated. These applications are described generally as control functions. Many of them are the man-machine interface that provides selectivity, versatility and variability to a circuit or system. The type of potentiometer used may vary according to specific needs, but usually the wiper travel is manually controlled by the turning of a knob or turns counting dial. Cost-effective circuit design and application of the potentiometer depends on the designer having a broad knowledge of the economical options available.

Applications for *precision* control devices are sometimes electromechanical and usually re-

quire greater mechanical accuracy, better stability, and longer life. They may also be subjected to severe environments. These applications are discussed in the next chapter.

Control functions can generally be classified as one of the following:

- Calibration — *How much correction?*
- Level — *How much?*
- Rate — *How fast?*
- Timing — *How soon?*
- Position — *Where?*

Many of the techniques described in Chapter 4 are directly applicable to control applications. The sections regarding gain adjustment of operational amplifiers, filters, and frequency control are of particular interest. One difference between Chapter 4 applications and those here is *how often* the adjustment may be needed.

These application examples represent a very small sample of the huge number possible. The brief descriptions give a general idea of the type of control functions which use potentiometers.



**BASICS OF CONTROL**

Before looking at specific applications, some fundamental guidelines of good control function design should be considered. Although some of the ideas may seem very obvious, each one should be carefully considered as a factor in the design of a control scheme for an instrument or system.

**Control the actual function of interest.** It is usually possible to control a function in a number of ways. Some may be rather direct while others may require an indirect approach. Where practical, the control function scheme should provide the operator with a direct relationship between the position of the control dial and response of the controlled variable. This is in line with good human engineering and should be followed where practical.

An example will make this clearer. Suppose that the *on* time of a simple oscillator must be controlled. One possible circuit is shown in Fig. 5-1. As shown by the operational equations, the setting of the potentiometer wiper is affective in determining the charging ( $t_1$ ) and discharging ( $t_2$ ) time constants of the circuit. Varying  $R_2$  will change the amount of time  $t_1$  that the output is high.  $R_2$  also varies the time  $t_2$  during which the output is low. The controlled function is actually the *frequency* of the oscillator.

In Fig. 5-2, two potentiometers are used to allow independent control of  $t_1$  and  $t_2$ . A few

additional components allow one potentiometer  $R_2$  to be active only during the charging cycle, thus controlling  $t_1$ . The other potentiometer  $R_3$  is active only during the discharging cycle, thus controlling  $t_2$ . If only  $t_1$  control is needed,  $R_3$  may be replaced by a fixed resistor of appropriate value.

Note in Fig. 5-2 that a fixed resistor is included in series with  $R_2$ . This prevents possible component damage in case both potentiometers are set to their minimum resistance values. A fixed resistor could be placed in series with  $R_3$  to achieve greater values of  $t_2$ .

In some applications, it is required to control  $t_1$  while the oscillator frequency remains constant. This can be done with the circuit of Fig. 5-2 by decreasing  $t_2$  each time  $t_1$  is increased. Although the circuit arrangement achieves the requirements, the overall adjustment procedure is more complicated and requires greater operator care and skill than necessary.

Direct control of  $t_1$  is easily accomplished by the circuit shown in Fig. 5-3. The oscillator frequency is a function of the potentiometer's total resistance only, and is not affected by wiper position. When the control is actuated, the division ratio of  $R_1$  changes. Since the total resistance of  $R_1$  is constant, the output frequency will remain constant while the variable division ratio provides a variable duty cycle. The duty cycle is directly proportional to the relative wiper travel.

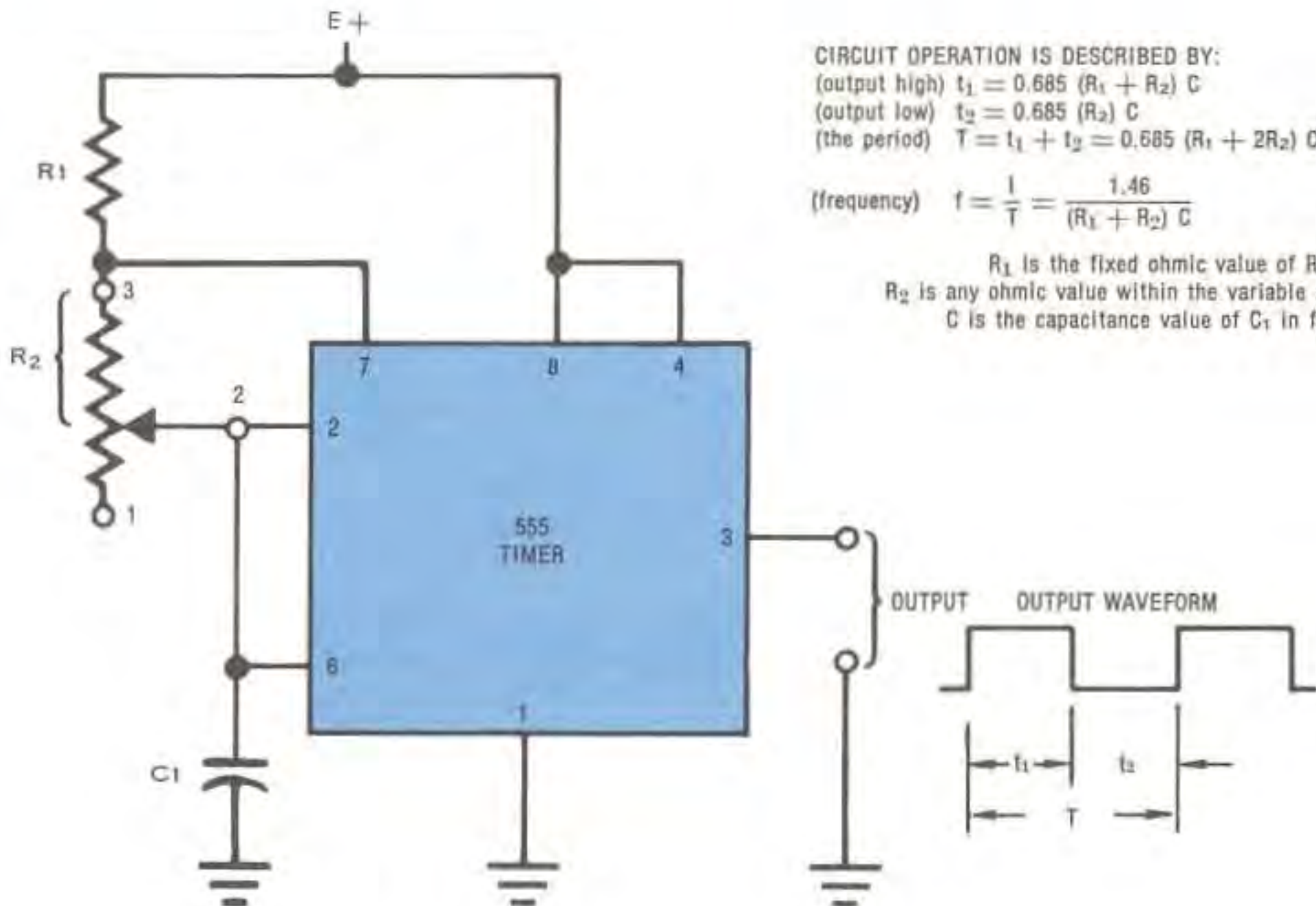

**Fig. 5-1** A potentiometer provides control of frequency in an oscillator circuit



It can be indicated on a read-out dial.

Control requirements should be carefully analyzed to make certain that the circuit chosen satisfies those requirements in the most *direct* manner. This will result in the most cost-effective approach with a logical man-machine interface.

**Provide adequate range and resolution.** The control arrangement must provide adjustment of the variable over the required range for the life of the system. Adequate adjustment margin must be provided to compensate for electronic component tolerances and aging effects. It may be necessary to restrict the control range somewhat or shape the control function in some

manner. Adjustment resolution must be adequate for the specific application. Methods for achieving various responses are discussed in Chapter 3.

**Choose a logical direction of control sense.** The control sense refers to the direction of change in the controlled function compared to the direction of change in mechanical input rotation or wiper movement. The criteria for choosing a control sense are those factors dictated by good *human* engineering. For example, a clockwise rotational input should cause the controlled function to increase while counterclockwise causes a decrease. In the case of linear

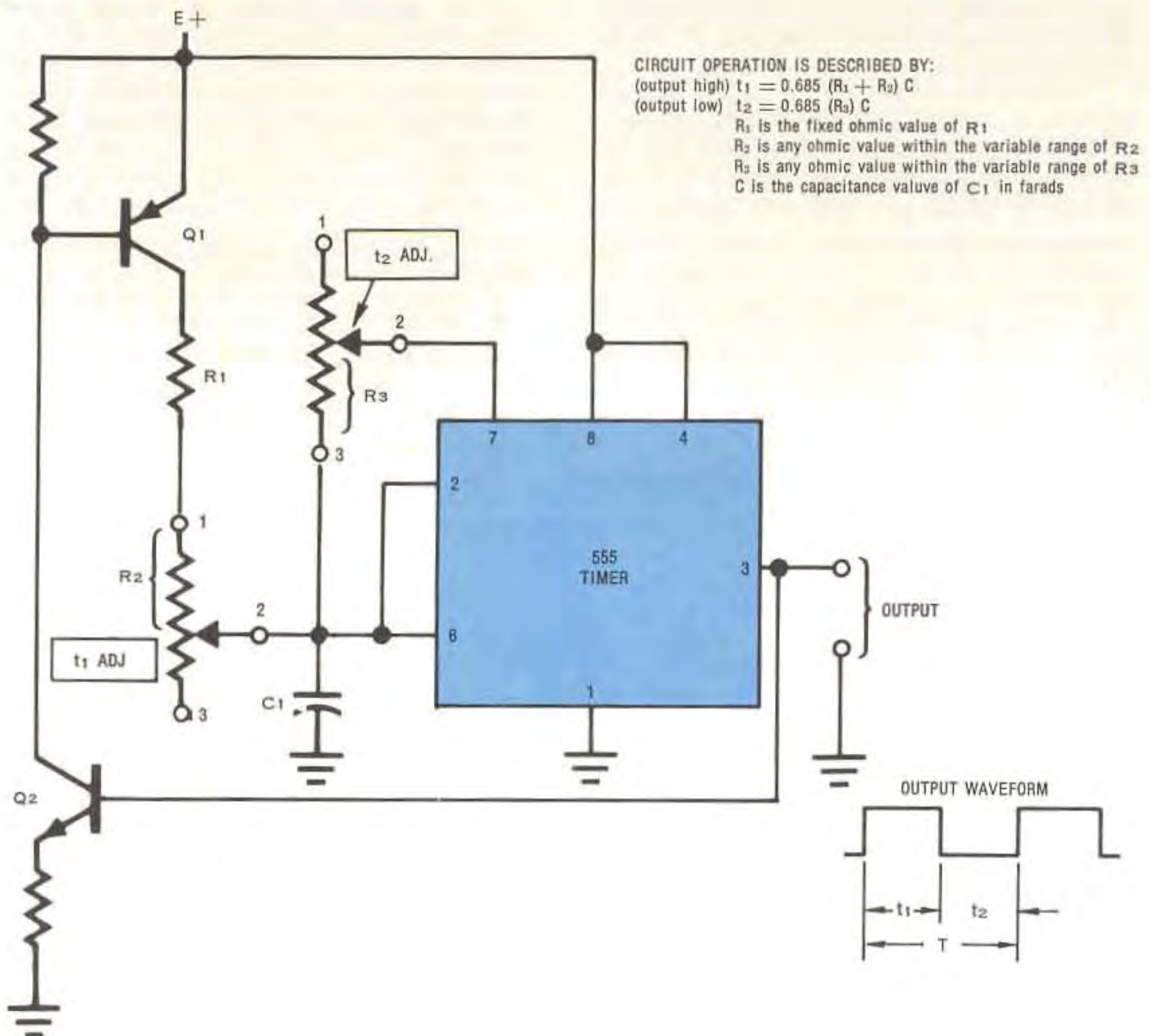

Fig. 5-2 Potentiometers provide independent control of ON and OFF times in an oscillator circuit



motion potentiometer controls, movement upward or to the right should increase; down to the left, decrease. Position controls should provide an upward or left-to-right movement for a clockwise rotation of the control knob.

As an illustration, suppose that a potentiometer is used to control a current through a low resistance load. A simple rheostat connection will accomplish the desired control function. The choice of end terminal should be such that a clockwise rotation of the adjustment shaft will produce an increase in current.

In control sense selection, primary consideration should be given to how the operator will view the control function. Say a control is provided for changing the period of an oscillator but the operator will be interested in the resultant frequency change. Clockwise rotation should cause a *decrease* in period so that the operator will experience *increase* in frequency for clockwise rotation.

Changing the control sense after final circuit assembly is a simple task. This may be necessary where, after check out, it is discovered that the man-machine interface *seems* backwards or unnatural. Reversing the wires connected to the

end terminals will invert the control sense for a voltage divider. For a rheostat, simply remove all connections from the end terminal being used and connect them to the other end terminal.

**Assume worst case conditions.** When a potentiometer is designed into a system as a control device, assume that the wiper will be set to all possible positions. Don't be satisfied and feel safe with a warning contained in an instruction manual which might say, *Do not turn the gain control more than 75 percent of the full clockwise position.* If there is a possibility of circuit failure beyond a *safe* limit, *design in* a control range restriction. Remember Murphy's Law: The instruction manual will not be read until all else fails, a control knob will be inadvertently bumped and the skill level of the operator will be much lower than required.

**Make controls independent.** Whenever possible, make all controls independent so that adjustment of any one will have no affect on the setting of another. If this is not practical, attempt to cause the dependence to be restricted to one direction. If this is done, the operator first adjusts the independent control, then the affected dependent control, without having to go back

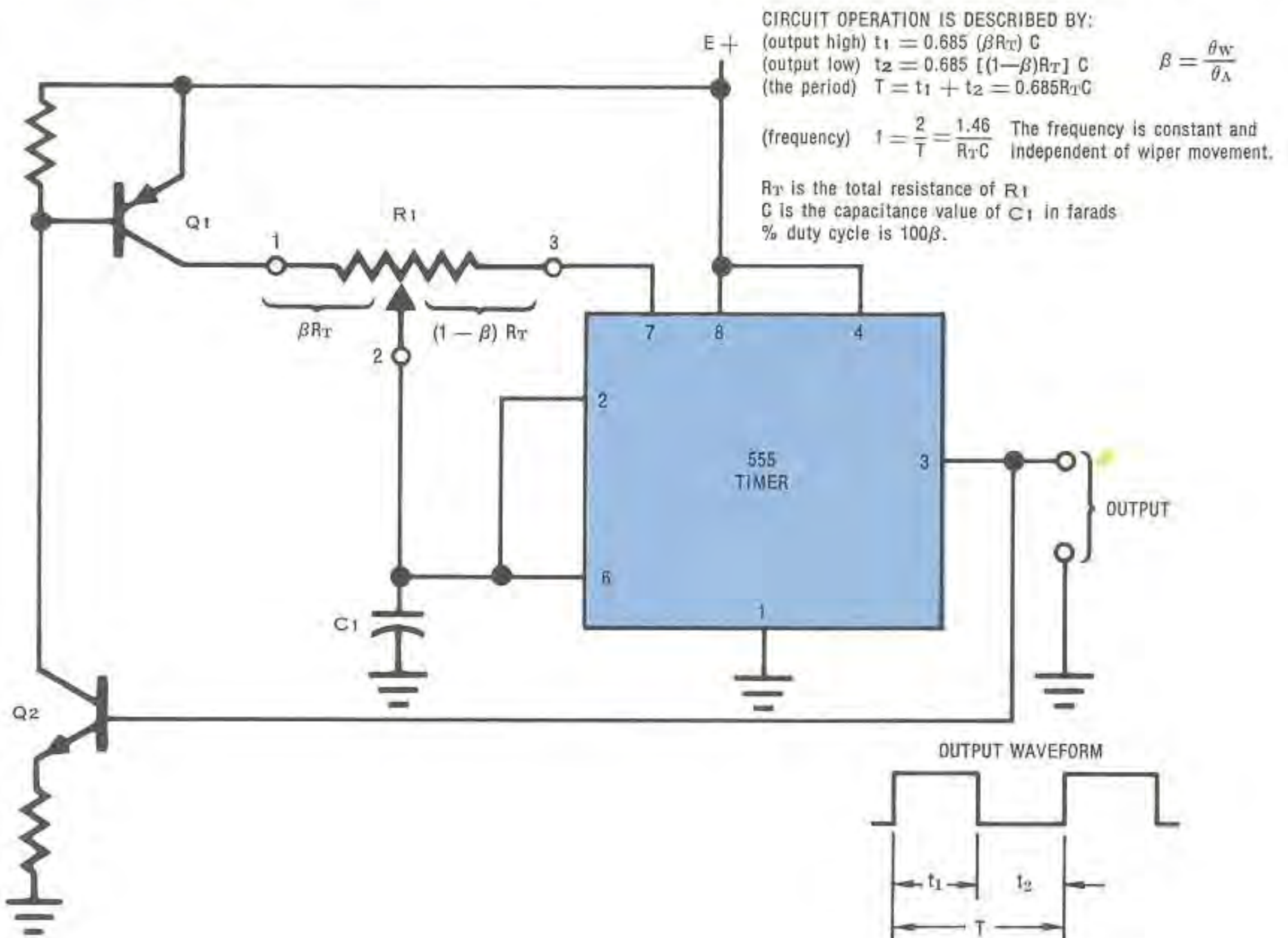

Fig. 5-3 A potentiometer controls the percent duty cycle in an oscillator circuit



and forth. When dependent controls cannot be avoided, adjustment instructions should clearly indicate the proper sequence of adjustment for minimum interaction.

**Consider the shape of the controlled function (output curve).** Many control requirements are satisfied by the characteristics of a linear function potentiometer. Some applications, however, require a potentiometer with a non-linear function characteristic. This is easily accomplished for applications that permit the use of carbon element potentiometers which are available in a wide variety of functions. If stability requirements will not permit the use of a carbon element potentiometer, then consider a potentiometer with a cermet or wirewound element.

In some applications, the control function may be shaped using the methods described in Chapter 3. It is possible to change the effective shape of the control function by proper arrangement of the control circuit.

Suppose the current through a resistive device is to change linearly with respect to the adjustment of a control potentiometer. Adjusting the current by changing the resistance in the circuit loop (rheostat) will produce a hyperbolic function whereas adjusting the voltage across the resistance in a linear fashion will satisfy the current linearity requirement.

**Consider environmental and stability requirements.** The potentiometer, when properly designed and applied, will not respond to temperature, vibration or shock, beyond its established tolerance limits. Choose an element type and a mechanical construction style that will yield sufficient stability for the application.

If high vibration may be present during circuit operation, choose a potentiometer model that provides a means for mechanically locking the wiper in position. A simple friction brake may be added to the shaft in many instances. Some potentiometer designs have inherent friction which results in a high torque to actuate the wiper. This high torque provides greater stability under vibration.

Additional precautions against a harsh environment include a water-tight seal to the control panel or protection of the control devices with a cover which must be lifted when adjustments are necessary. There are many combinations of environmental factors possible. The most expedient and cost-effective approach is to discuss a particular application with a potentiometer manufacturer.

**Choose a proper location.** Controls which must be adjusted often should be easily accessible. This seems obvious but is sometimes overlooked and difficult to correct after a system is built. Other influences on control location, e.g.,

noise susceptibility and stray capacitance, may require that the control potentiometer be located deep within the equipment. A rigid or flexible shaft extension connected to a front-panel knob can be used.

## INSTRUMENT CONTROLS

Potentiometer controls serve many functions on various instruments including those for test and measurement. A few examples will give an idea of typical control possibilities.

**Oscilloscopes.** A modern test oscilloscope has many potentiometric controls as indicated in the photograph of Fig. 5-4. Controls are provided for focus, beam intensity, beam and graticule illumination, and beam positioning. Other controls allow adjustment of triggering level and polarity. Even the normally fixed calibration switches controlling the input voltage sensitivity and sweep speed employ potentiometers to provide some degree of variable control between ranges.

**Function Generators.** Control potentiometers are used for many functions in both digital pulse and analog function generators. Fig. 5-5 shows a simplified schematic diagram of a function generator with the potentiometers emphasized. Note that most of the front panel control functions from triggering level to output level use control potentiometers. Trimmer potentiometers, also shown in Fig. 5-5, are used for many of the calibration functions.

The block diagram of a typical pulse generator is shown in Fig. 5-6. In the case of clock frequency, delay time, and pulse width, capacitors are switched to provide the typical decade range changing. Potentiometers provide the necessary fine adjustment within a given range.

Additional control potentiometers are indicated for adjusting the trigger sensitivity and output level.

**Power Supplies.** Adjustments on fixed voltage power supplies are usually made with a trimmer as discussed in Chapter 4. Laboratory power supplies, on the other hand, require frequent adjustment of output voltage and output current limit. These use control potentiometers with knobs easily accessible to the operator. Here the results are monitored for control with a meter rather than calibrating the input using a pointer or indicator line.

Fig. 5-7 gives the schematic of a versatile laboratory power supply. Control potentiometers permit both coarse and fine adjustment of either the output voltage or output current. These control potentiometers need no calibration dial since meters on the panel indicate the resulting current or voltage same as explained above.

Some power supplies use a multiturn poten-



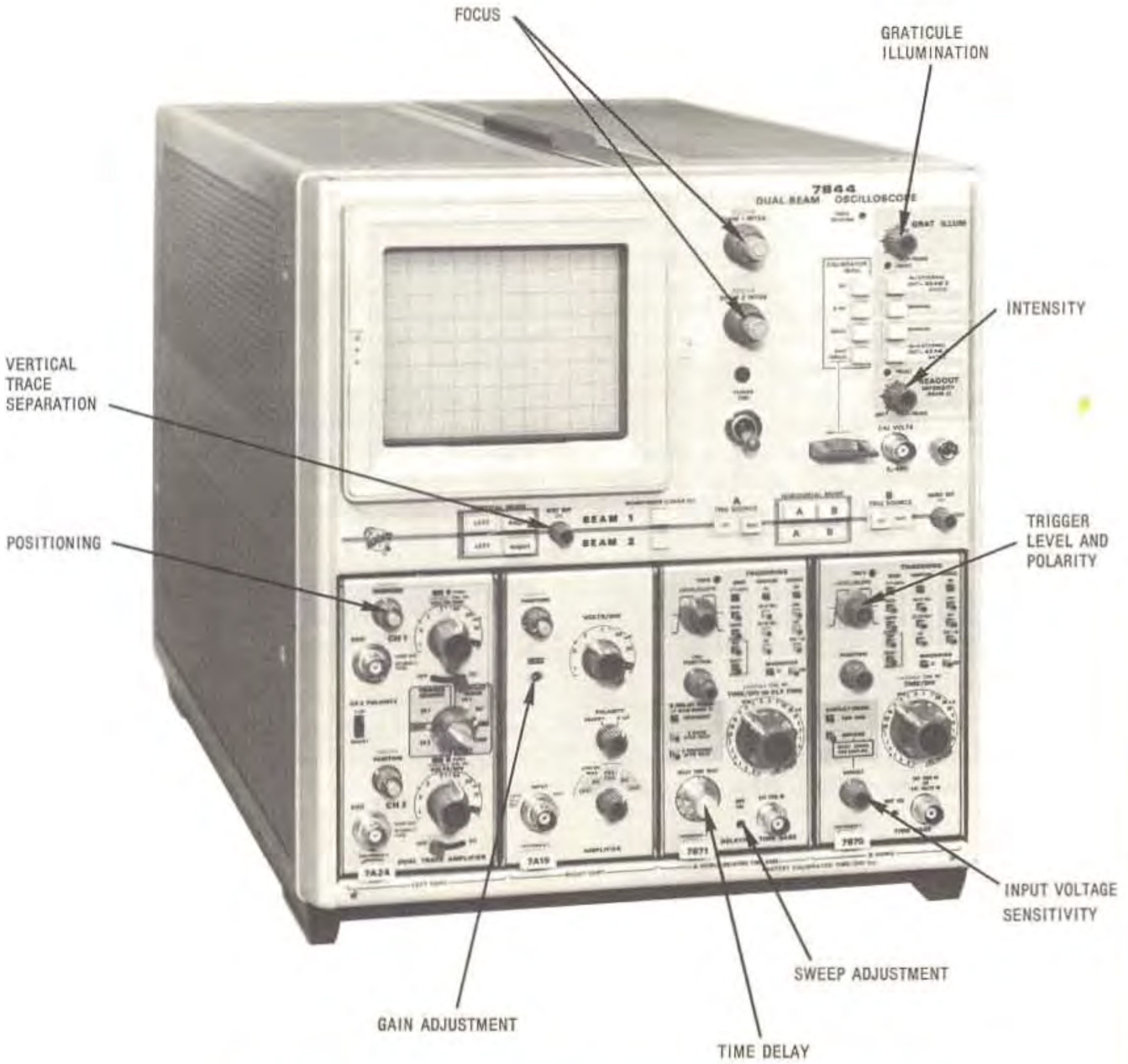

**Fig. 5-4** Variable resistance controls contribute to the versatility of the modern test oscilloscope (Tektronix, Inc.)



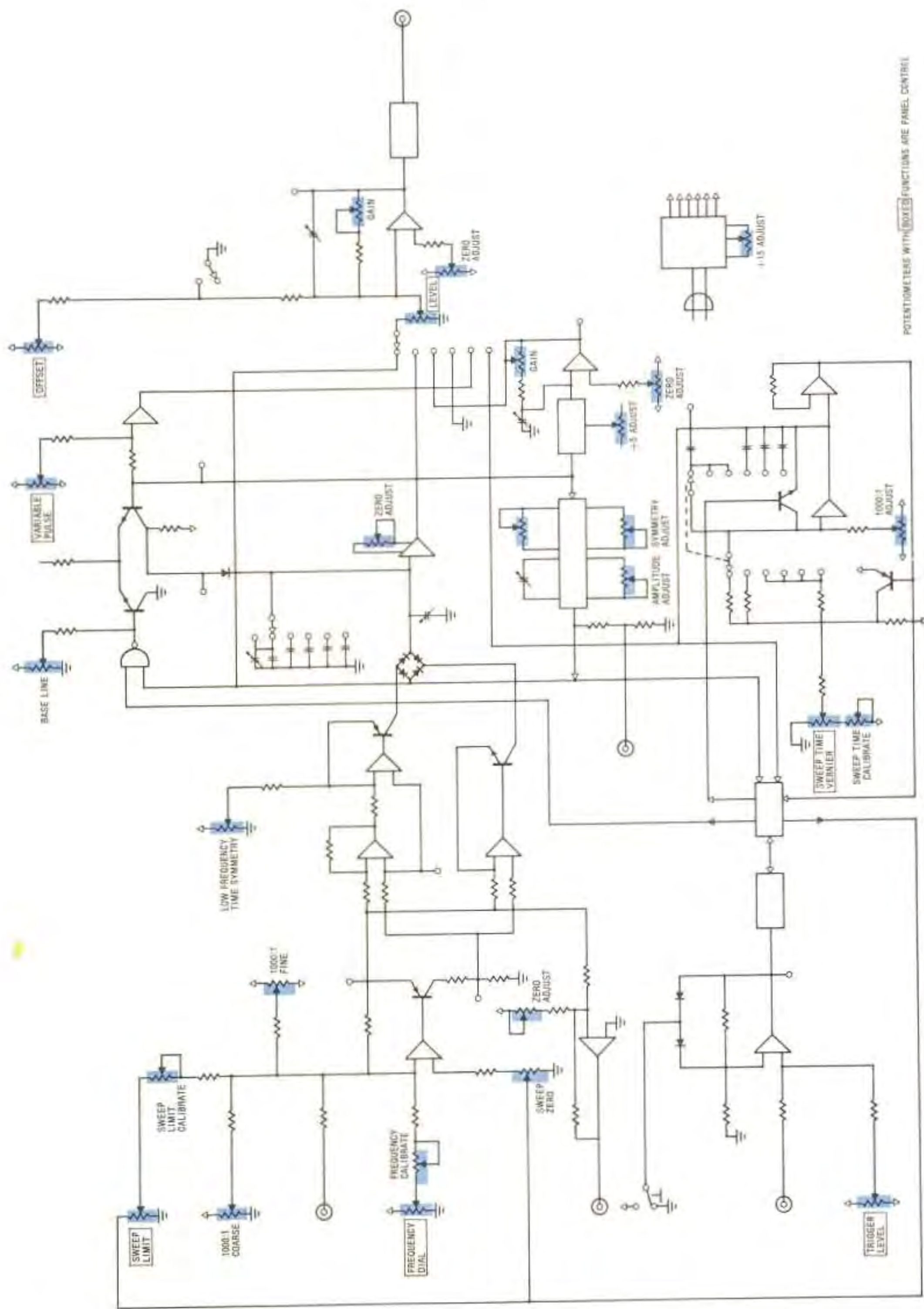

Fig. 5-5 Function generator uses potentiometers for panel controls and calibration adjustment (Interstate Electronics Corp.)



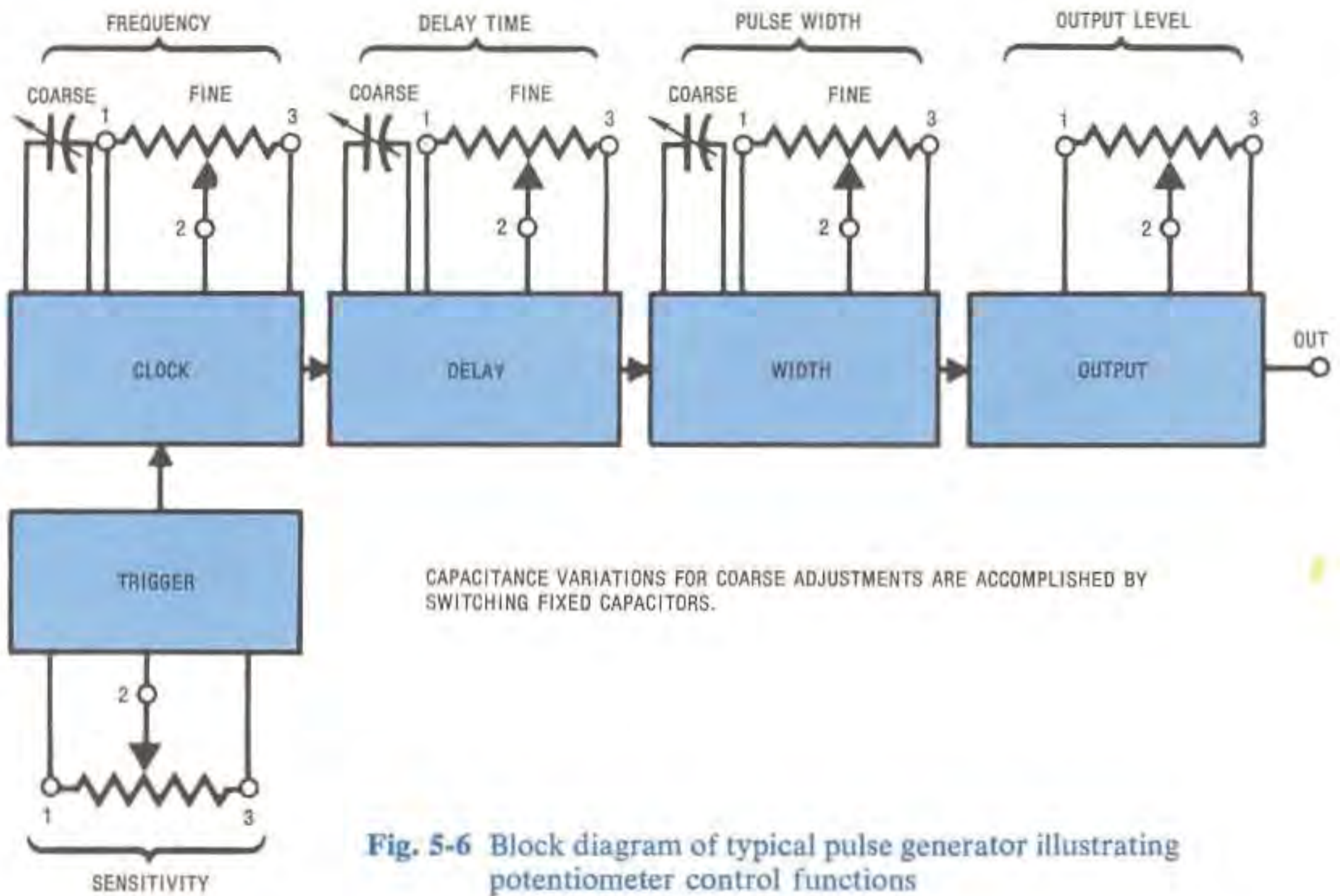

Fig. 5-6 Block diagram of typical pulse generator illustrating potentiometer control functions

tiometer, rather than a single turn, to provide adjustability of the control function. This results from the better resolution provided by multi-turn devices.

**Photometers.** An example of a correction function performed by a control potentiometer is shown in Fig. 5-8. The dark current in a photomultiplier tube varies from unit to unit and over the life of the tube. In addition, it is temperature sensitive. Proper operation of the photometer requires frequent adjustment to compensate for dark current variations.

**Recorders.** Strip-chart and X-Y recorders use control potentiometers for pen reference positioning. A voltage signal is injected into the servo system to produce an adjustable error to compensate for other possible errors. This variable voltage moves the pen zero reference to any desired position within its normal operating range. Usually, the position signal is fed in at a high-level point in the system after the preamplifiers and range attenuators.

In some units, a very wide input offset adjustment is provided to allow an expanded scale display at some level above ground. Good resolution and stability in this application are absolute necessities.

Another control potentiometer is frequently included in order to provide a variable sensitiv-

ity. Earlier recorders also included a servo gain control on the front panel, but better designs have permitted this control to be delegated to an infrequent adjust trimmer.

**Meters.** Control potentiometers are used for meter zeroing on dc analog meters as illustrated by the control labeled *zero* in Fig. 5-9. Although contemporary solid-state designs are much more stable than the older vacuum tube models, a certain amount of operator adjustable zero control is necessary at very low voltage levels. The total zero adjustment range provided for the instrument illustrated is only  $\pm 15$  microvolts.

Another control, labeled *null* in Fig. 5-9, is provided to adjust an internal voltage supply in order to produce an input zero offset. Good resolution and stability are required. Note that an adjustment potentiometer is available to set the output level for an optional external recorder.

## AUDIO

Perhaps the most frequently adjusted type of potentiometer control is the volume on radios, audio amplifiers, and television sets. Carbon element potentiometers are generally used, and the function is usually logarithmic, to more closely match the nonlinear response of the human ear. This logarithmic resistance variation is commonly referred to as *resistance taper*.







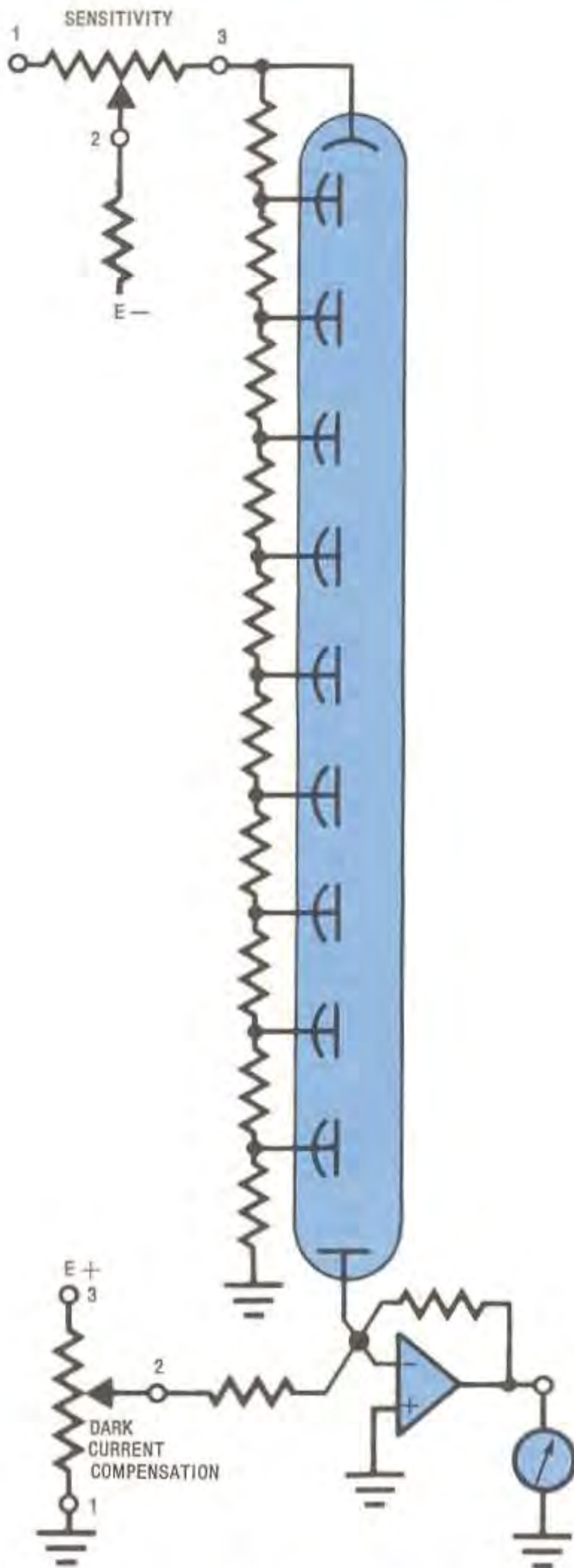

**Fig. 5-8** Photometer circuit uses potentiometer control to compensate for photomultiplier dark current

**Resistance Taper.** Resistance taper is the output curve of resistance measured between one end of the element and the wiper. It is expressed in percent of total resistance *versus* percent of effective rotation. Three resistance tapers have

been established as standard by military specifications and by industry usage. These three standard tapers – linear, clockwise audio, and counter-clockwise audio – are shown in Chapter 7, Fig. 7-13. Most manufacturers list other standard resistance tapers and produce special tapers on request.

In recent years linear slide potentiometers have become popular in audio applications and may some day surpass rotary control usage. Some rotary type potentiometers are actually actuated by a linear motion via a mechanical linkage. Other audio controls include ones for tone and balance. On stereo systems, a set of controls is usually provided for each channel.

The master mixer board Fig. 5-10 found in recording studios uses sliding type potentiometer controls to adjust the level of each input channel. Since these units are frequently adjusted during the recording session, smooth operation and a low noise level are required. Rotary potentiometers are used for control of special effects, i.e., output to an echo chamber and returning input to the console.

### MISCELLANEOUS CONTROLS

Potentiometer controls are used in many forms both in the home and in industry. This section contains a few typical applications.

**Model aircraft remote control system.** The ingenious *single stick* positioner in Fig. 5-11A uses two space saving, conductive plastic potentiometers to provide the output that controls two independent model aircraft functions.

The complete RC transmitter shown in Fig. 5-11B uses two of the dual potentiometer assemblies to control a model's throttle, ailerons, rudder and elevator. The unit shown is actually a six-channel transmitter. The extra two channels are used for special controls such as landing gear retraction.

The *pilot* controls the model much like he would if he were at the controls of the real thing.

**Phase Shift Control.** In Fig. 5-12 dual ganged potentiometers are used to provide an adjustable phase shift from about 10 to 165 degrees for an input signal frequency of 400 Hz. By proper circuit configuration, a phase shift control is achieved without changing the output amplitude.

Control potentiometers are available in multiple ganged units and thus may be used to simultaneously change voltage, current, or resistance levels at different parts of the circuit. Even if tracking of these variables is imperfect, the availability of ganged controls adds a great flexibility to the designer's resources.

The equation included in Fig. 5-12 shows that phase shift is a nonlinear function of the resist-



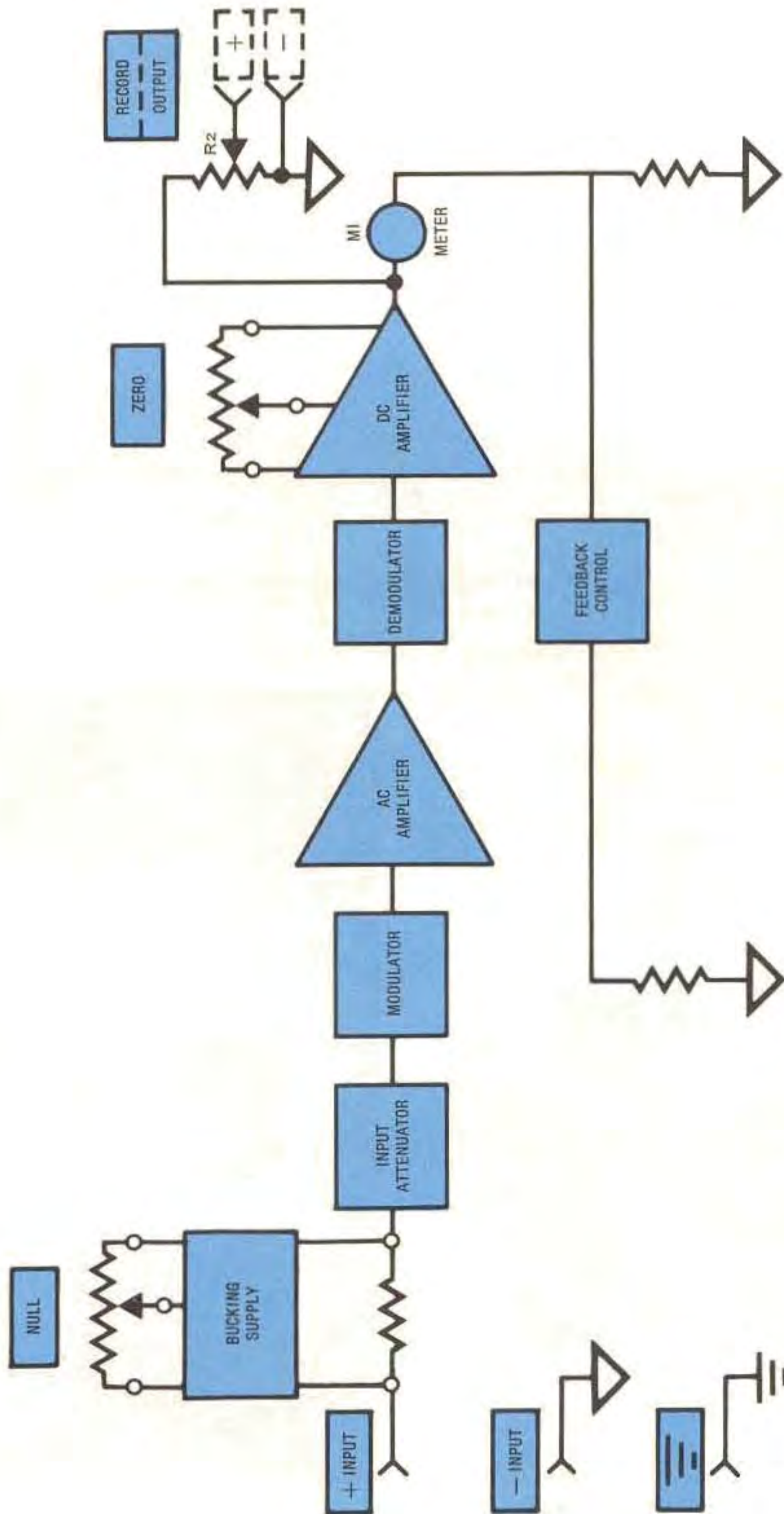
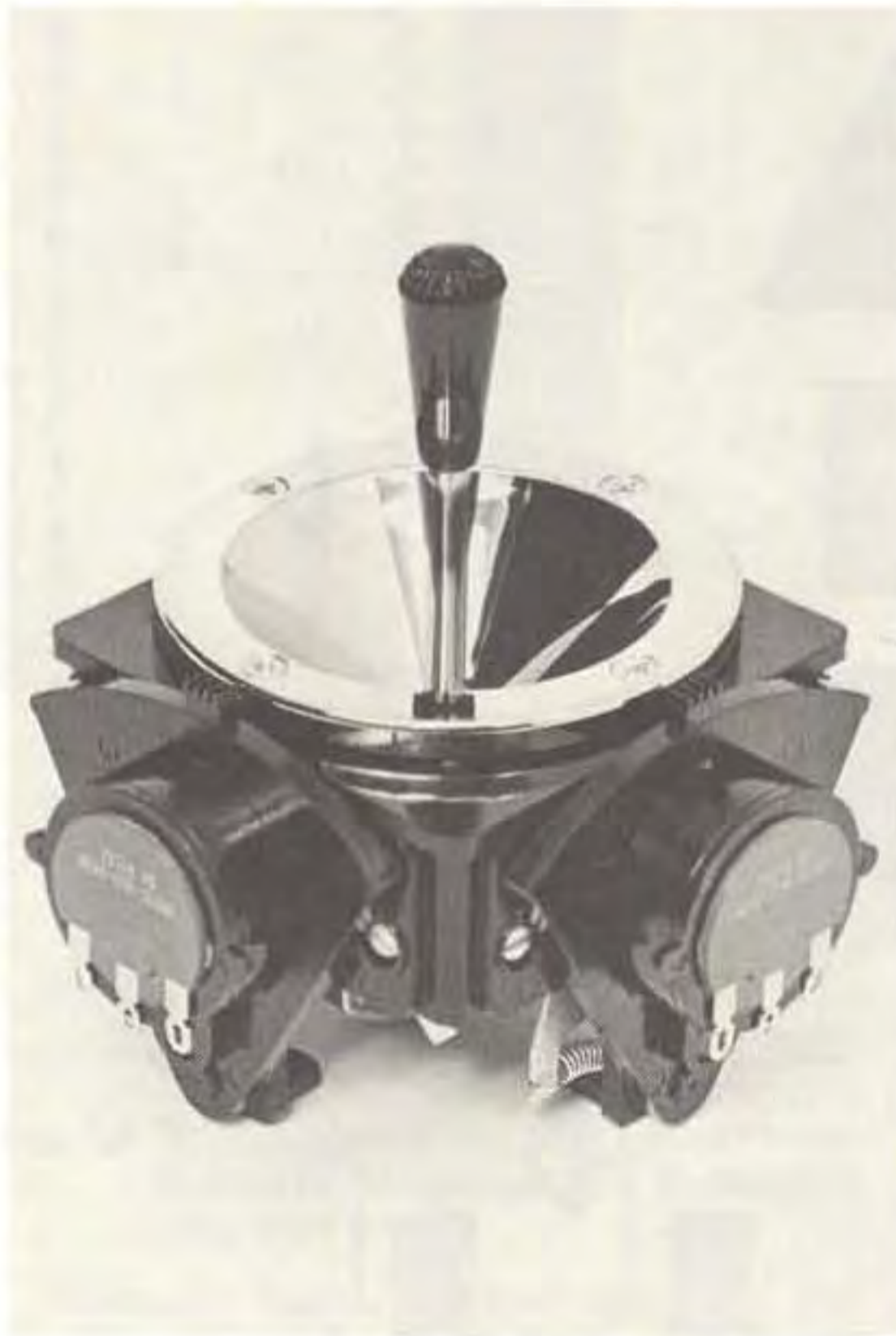

Fig. 5-9 Potentiometer controls are utilized for zero and offset null on this voltmeter (Hewlett-Packard)





**Fig. 5-10** Master mixer board for recording studio  
(Cetec, Inc.)



A. SINGLE STICK POSITIONER



B. SIX-CHANNEL TRANSMITTER

**Fig. 5-11** Remote control system for model aircraft  
(Kraft Systems, Inc.)



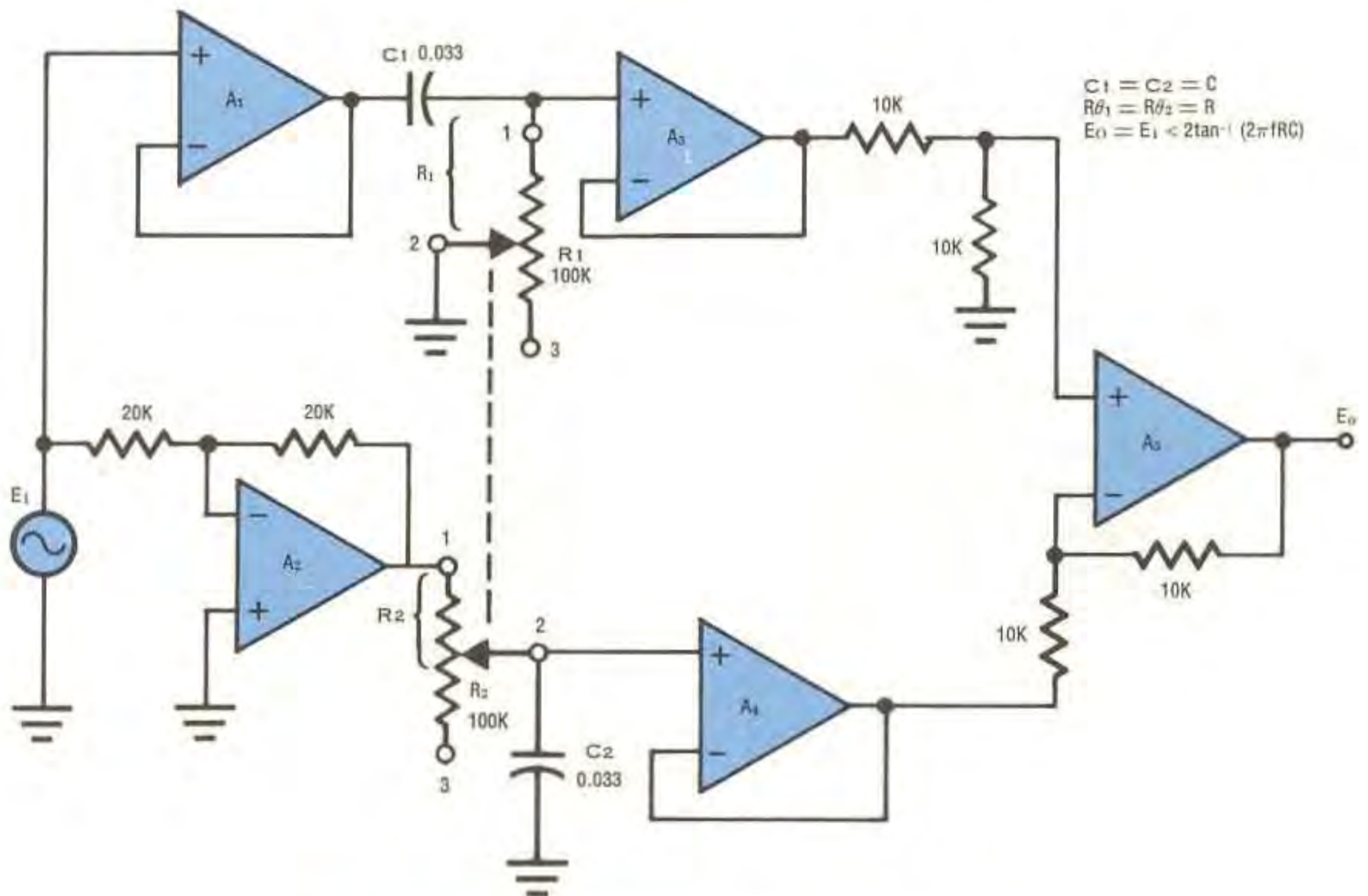

Fig. 5-12 Ganged potentiometers yield phase shift control

ance value. If the potentiometer elements have a logarithmic transfer function, a smoother phase shift control is obtained.

**Attenuators.** A very common control used in communications equipment is the constant impedance variable attenuator. Fig. 5-13 shows five typical circuit configurations for these attenuators. The unique characteristic of all these configurations is to maintain the input impedance and output impedance at an equal and constant level as the amount of attenuation (from input to output) is varied.

All five of the circuits shown in Fig. 5-13 perform an identical function. The difference in the configurations is the accuracy with which it performs that function. The circuits are arranged in relative order of accuracy. Fig. 5-13A is the least accurate and Fig. 5-13E is the most accurate.

For the bridged T configuration of Fig. 5-13B, to keep the impedances constant requires maintaining the relationships:

$$R_1 = Z(K-1) \text{ and } R_2 = \frac{Z}{K-1}$$

where  $K = \text{antilog} \left[ \frac{A}{20} \right]$  and A is the attenuation in decibels (db).

Solving the above relationships for K and setting them equal to each other:

$$R_1 R_2 = Z^2 = \text{constant}$$

This condition can be achieved by constructing R1 and R2 to produce a logarithmic output function. R1 must be counterclockwise logarithmic and R2 clockwise logarithmic. R1 and R2 must be mounted in a common shaft.

**Motor Speed Control.** Modern drill motors have great versatility because of adjustable speed control. A simple circuit is included within the case. This circuit uses a potentiometer and a triac in the manner shown in Fig. 5-14. The operator squeezes a trigger that is mechanically linked to the potentiometer. The potentiometer setting determines the point in the input voltage cycle where the triac is turned on and, hence, controls the average voltage applied to the motor. This allows a very large range of usable motor speeds.

Relatively small potentiometers teamed with modern solid-state circuitry are used to control the speed of very large motors. The control point can be right at the motor, as in the case of the drill motor or a blender, or it can be at some remote point more convenient to the opera-



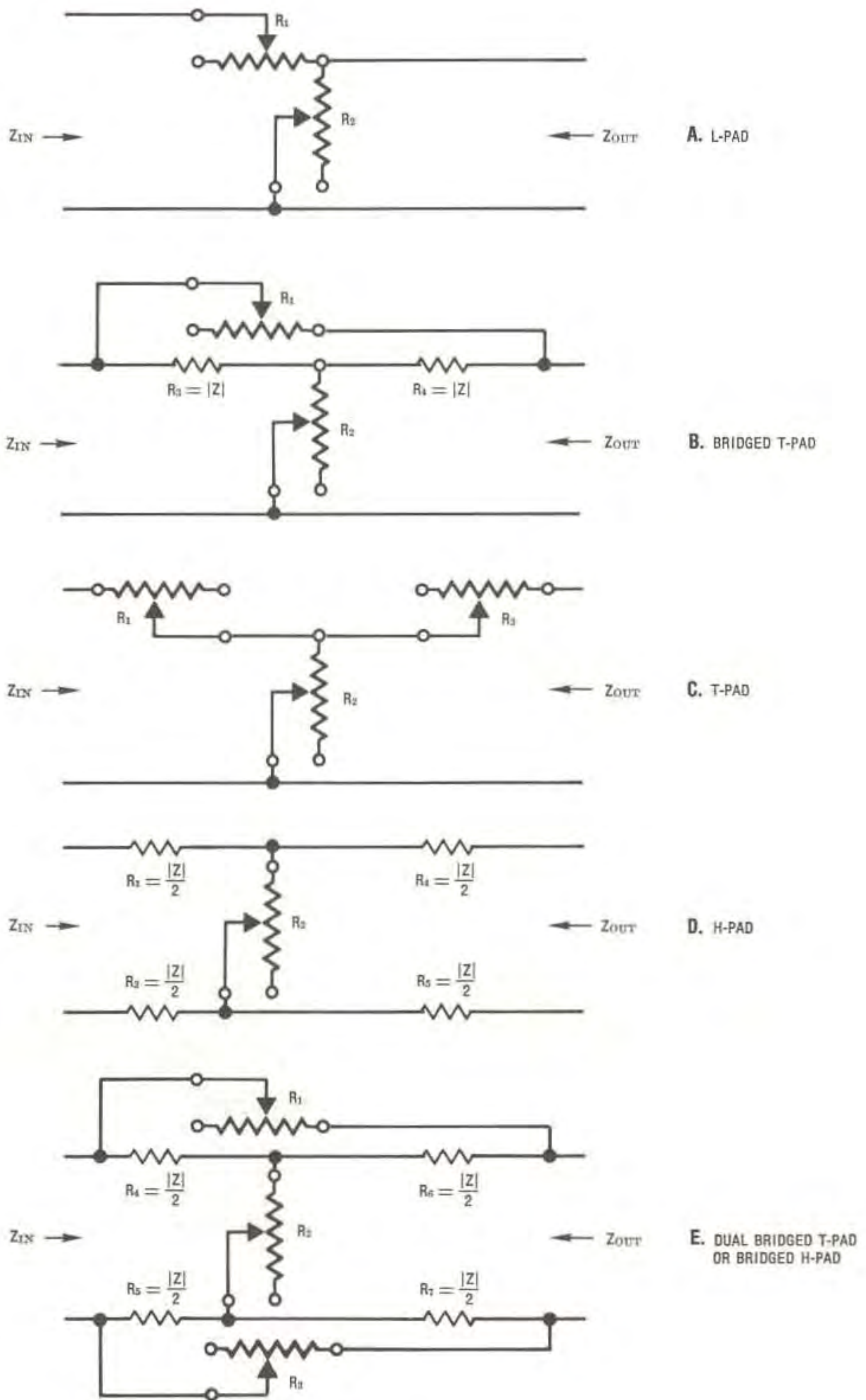

Fig. 5-13 Various circuit configurations for constant impedance attenuators



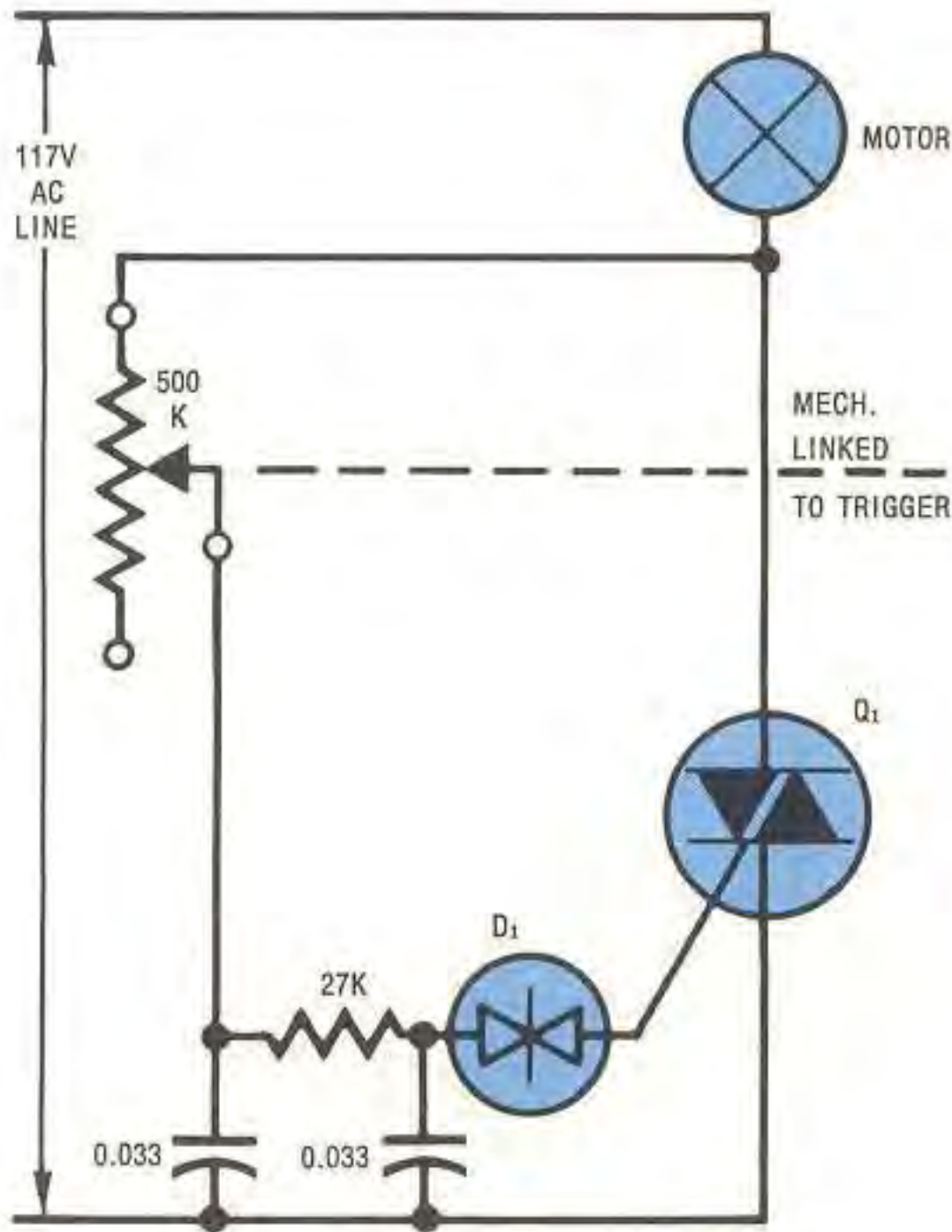

Fig. 5-14 Simple motor speed control

tor. Even with great separation, the man-machine interface capability of potentiometers is effective.

**Temperature Control.** Control potentiometers may be used to adjust the amount of power supplied to a heater, or they may be included in a temperature servo control to adjust the set point.

The same basic circuit shown in Fig. 5-14 may be adapted to control the amount of ac power supplied to a heater element. By adjusting heater power with a potentiometer the operator controls the operating temperature indirectly.

For *precise* temperature control, a servo feedback system could be used to adjust the amount of power and thus the temperature of the heater. In operation, the desired temperature is preset by a control potentiometer. When the operating temperature, as monitored by a temperature sensor, is below the setpoint more power is applied to the heater. Usually, the sensing transducer and the control potentiometer are part of some form of bridge circuit such as that shown in Fig. 5-15.

In this circuit, the bridge is balanced when the sum of  $R_3$  and  $R_4$  bear the same ratio to  $R_5$

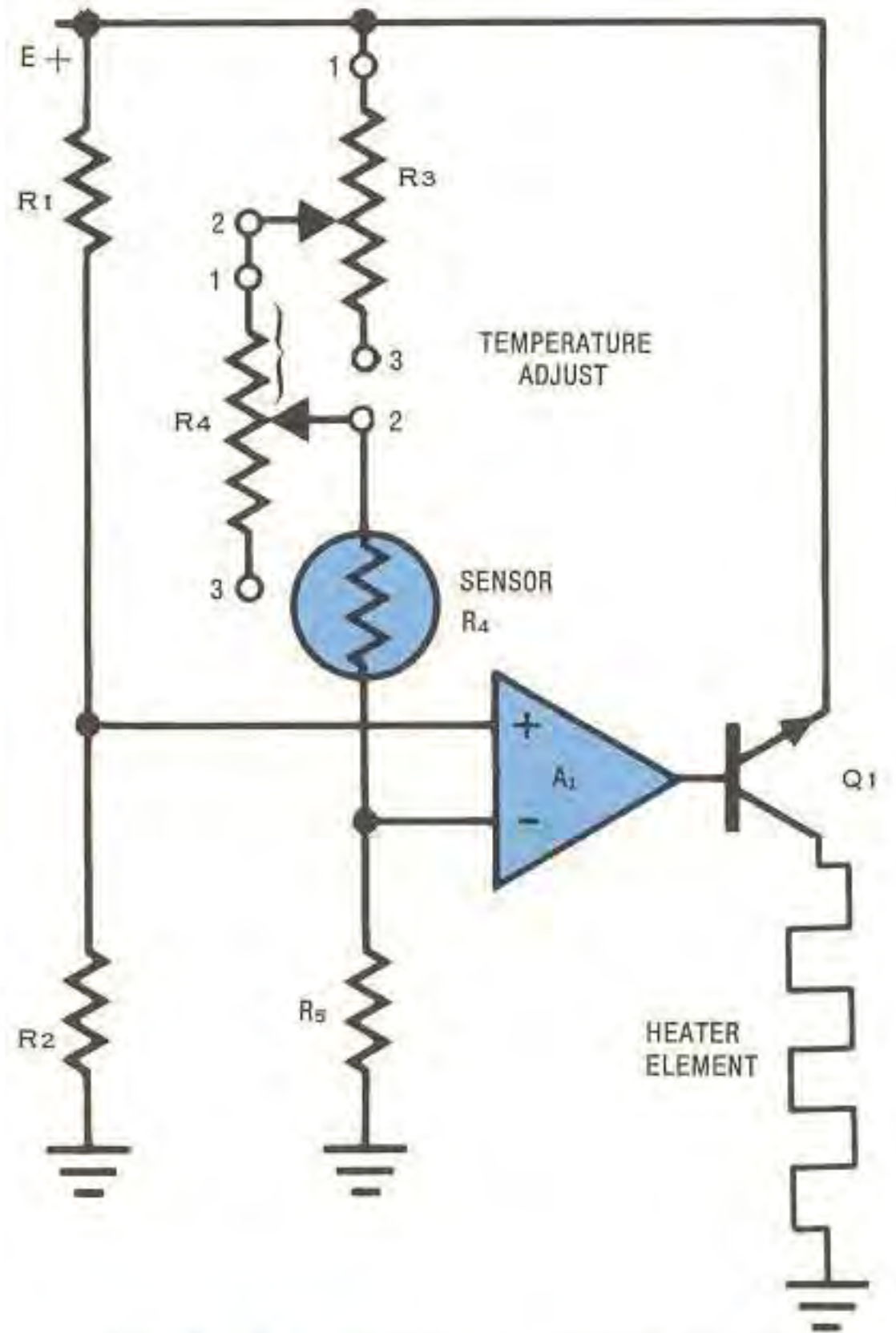

Fig. 5-15 Temperature control circuit uses a balanced bridge

as  $R_1$  does to  $R_2$  or:

$$\frac{R_3 + R_4}{R_5} = \frac{R_1}{R_2}$$

If the sensor resistance is high, causing an imbalance in the bridge, it indicates the temperature is low. Then the error produces a positive output voltage from amplifier  $A_1$  and heater power is increased an amount determined by the temperature error and the voltage gain of  $A_1$ .

When the resistance of the sensor drops below the balance point in the bridge, indicating that the temperature is too high, then the output voltage from  $A_1$  is negative. This will turn off transistor  $Q_1$  and no heater power is supplied to the heater element.

Making the gain of  $A_1$  very high will result in a system in which heater power goes from off to full on with a very small temperature change. On the other hand, a moderate voltage gain will yield a more or less proportional control in which the amount of power supplied will be proportionate to the temperature error.



The relative positions of the sensor and control potentiometer in the circuit may be changed if the temperature coefficient of the sensor is positive rather than negative or the same bridge configuration may be used with the inputs to the amplifier reversed. The sensor and potentiometer could be relocated to opposite branches of the bridge, but the configuration shown always brings the bridge back to the exact same operating conditions with the same power requirement.

**Lighting Level Control.** Potentiometer controls may be used to vary light levels by adjusting the power applied to the lamps in a manner similar to that for heaters described in the preceding paragraphs. The control may be a direct one as is common for *mood* lighting control in homes or in stage lighting. It may be used in an overall servo system to control the exact set point of the light level using a photoelectric sensor.

Once again, a small, unimposing, low power control potentiometer may be used to control huge banks of high power lamps when it is applied with modern solid-state circuitry.

**Multifunction Control.** In fields such as tests and measurement, there is a great need for a

variety of front panel controlled switches and potentiometers. Often multiple functions are used on a single adjustment shaft or multiple functions are controlled by concentric shafts from the same front panel control. Also modest quantities of specials that vary from circuit-to-circuit are sometimes needed. An economical and versatile assembly with many options is manufactured in the configuration shown in Fig. 5-16. These are modular components in a standard, expandable package with a variety of functions available in each section at relatively low cost.

### SUMMARY

Control devices are used in applications in which frequent manual adjustment is anticipated and convenient adjustment is desired. Many of these applications involve man-machine interface. Cost-effective application of the control potentiometer depends on the designer's knowledge of economical options available.

Factors in the design of control applications and examples of typical control possibilities are listed in Fig. 5-17.

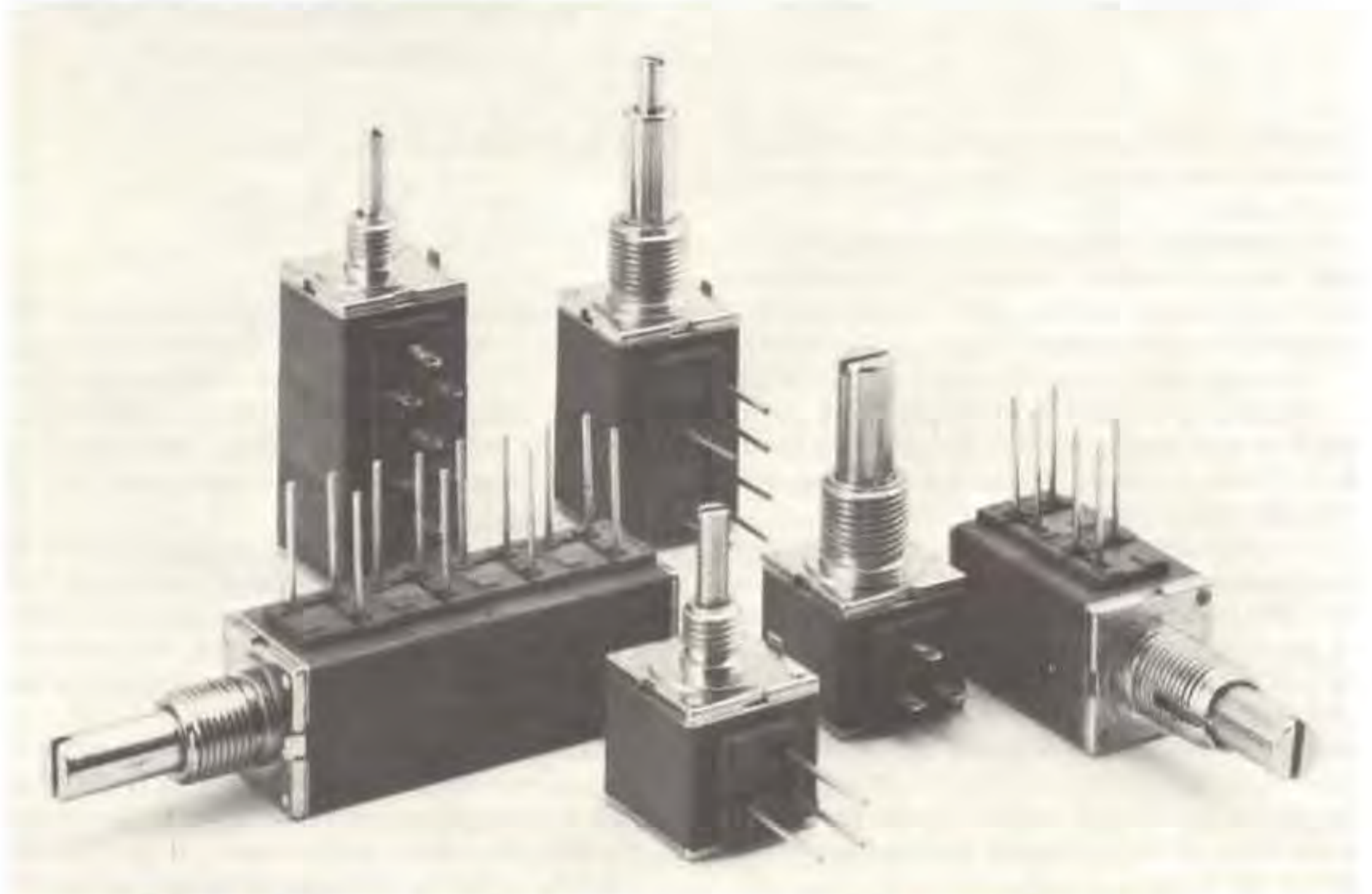

**Fig. 5-16** Multifunction control with modular construction provides a variety of functions including potentiometers and switches



Page	DESIGN FACTORS FOR CONTROL APPLICATIONS	Page	SOME TYPICAL CONTROL APPLICATIONS
			<b>INSTRUMENT CONTROLS</b>
98	Control the actual function of interest	101	Oscilloscopes
99	Provide adequate range and resolution	101	Function Generators
99	Choose a logical direction of control sense	101	Power Supplies
100	Assume worst case conditions	104	Photometers
100	Make controls independent	104	Recorders
101	Consider the shape of the controlled function (output curve)	104	Meters
101	Consider environmental and stability requirements	104	<b>AUDIO</b>
101	Choose a proper location		<b>MISCELLANEOUS CONTROLS</b>
		106	Model Aircraft Remote Control
		106	Phase Shift Control
		109	Motor Speed Control
		111	Temperature Control
		109	Attenuators
		112	Lighting Level Control
		112	Multifunction Control

**Fig. 5-17** Design factors and some typical control applications



# APPLICATION AS A PRECISION DEVICE

## Chapter

# 6

*You will find me wherever men strive to attain still higher levels of accuracy, and place no petty premium upon perfection. In the laboratory I am ever present amidst the chemist's test tubes and pipettes. In the observatory I am always at the astronomer's elbow. Each day I guide the fingers of a million pairs of hands, and direct the destinies of countless busy machines . . . I am Precision.*

*From an early advertisement by  
HERBERT H. FROST, INC.  
(Now CTS Corp.)*

## INTRODUCTION

Precision potentiometers find application where there is interest in the relationship between the incremental voltage level and the incremental displacement of a mechanical device. Often precision potentiometers are used in the simple control functions discussed in Chapter 5.

In this chapter the emphasis is on applications where a higher degree of accuracy is required than has been previously discussed. The importance of power rating, the effects of frequency, linear and nonlinear functions, and other electrical parameters are examined through the use of application examples. The examples include servo systems, coarse-fine dual level controls, and position indication/transmission systems. Since precision devices are electro-mechanical in nature, a discussion of them is not really complete with only electrical application data. Therefore Chapter 6 includes important mechanical parameters such as mounting, torque, stop strength, mechanical runouts and phasing.

## OPERATIONAL CHARACTERISTICS

The resulting performance of precision potentiometers is dependent not only on the wisdom of their design and the accuracy of their construction but also on the conditions under which they must perform. Some of the operational factors which effect the quality of performance or the duration of life include the excitation

(input) and wiper currents, the excitation frequency, the heat conductivity of the potentiometer mounting, and the temperature, pressure, and humidity of the surrounding environment.

In evaluating performance, the best method is to study the effects of each of the above factors separately. In any given application, however, the potentiometer is influenced by a combination of these factors. The resulting performance cannot be predicted by considering a mere linear summation of these effects. Recognizing this places more and more importance on the methods of environmental testing which simulate the actual conditions of application. With these methods the true reaction of any physical component to the particular environment can be reliably evaluated.

## POWER RATING

Power rating is an indication of a maximum power that can be safely dissipated by the device when a voltage (excitation) is applied to the end terminals. It is most often determined by a temperature-rise method. This prevents any part of the potentiometer from exceeding the maximum operating temperature at full rated power. For extremely accurate low-noise units the power rating should take into consideration noise, life, electrical and mechanical angles, the number of sections, and other functional characteristics.

The maximum power that can be dissipated is dependent upon the capability of the mounting structure to get rid of (sink) its heat by conduc-



tion or convection. This capability must be sufficient to keep the operating temperature of critical parts below levels which can cause permanent, physical damage. In certain less critical applications, such as those discussed in Chapter 5, potentiometers can function in the presence of minor physical deterioration. If the resistance element remains unbroken and the wiper continues to make satisfactory contact with the element, operation is not affected. In precision instrumentation, however, a minor increase in noise level or a slight dimensional shift in the resistance element may be prohibitive. Therefore, a meaningful power rating of a precision potentiometer should include a definition of the level of physical and electrical deterioration that can be tolerated in the particular application.

Potentiometers are not often fortunate enough to operate under laboratory mounting and ideal controlled environmental conditions. The tendency is to tightly package them with other components that may create greater temperatures. In Fig. 6-1 typical power derating curves are used to illustrate the relationship between power rating and basic potentiometer size. The curves shown are based on metallic cases and wirewound resistance elements. These curves are for single section devices. When sections are added the result is a power rating (for multicup units) that is 75% of the single section rating. The curves clearly indicate that operation at temperatures below 70°C is conducive to longer life. Voltage

excitation limits are usually determined by the insulation resistance of the resistance wire, in other words, the allowable voltage drop per turn of the resistance winding.

Fig. 6-2 shows how the power dissipation capability of wirewound potentiometers changes with diameter. The trend varies roughly as a square law because of its relationship to the device's surface area. Single turns with metal cases and ten turns with plastic cases are illustrated. The curves do not go to zero for the hypothetical potentiometer of zero size because any plate on which a potentiometer is mounted will have some heat sink capability.

Special considerations are necessary when the potentiometer is connected as a rheostat. The power capability depends upon how much of the resistance element is employed and thus upon the position of the wiper. Fig. 6-3 is a power derating curve for rheostats with wirewound resistance elements and metallic cases. This curve pertains to all sizes and is presented in terms of the percent of maximum power rating. The shape of the derating curve is interesting and shows the surprising fact that 50% of the total rated power can be dissipated satisfactorily by only 20% of the resistance element. This is due to the fact that the case and the remainder of the winding serve to conduct heat away from the small portion of the winding actually being used.

Fig. 6-4 shows a power derating curve for potentiometers with plastic cases. Because of

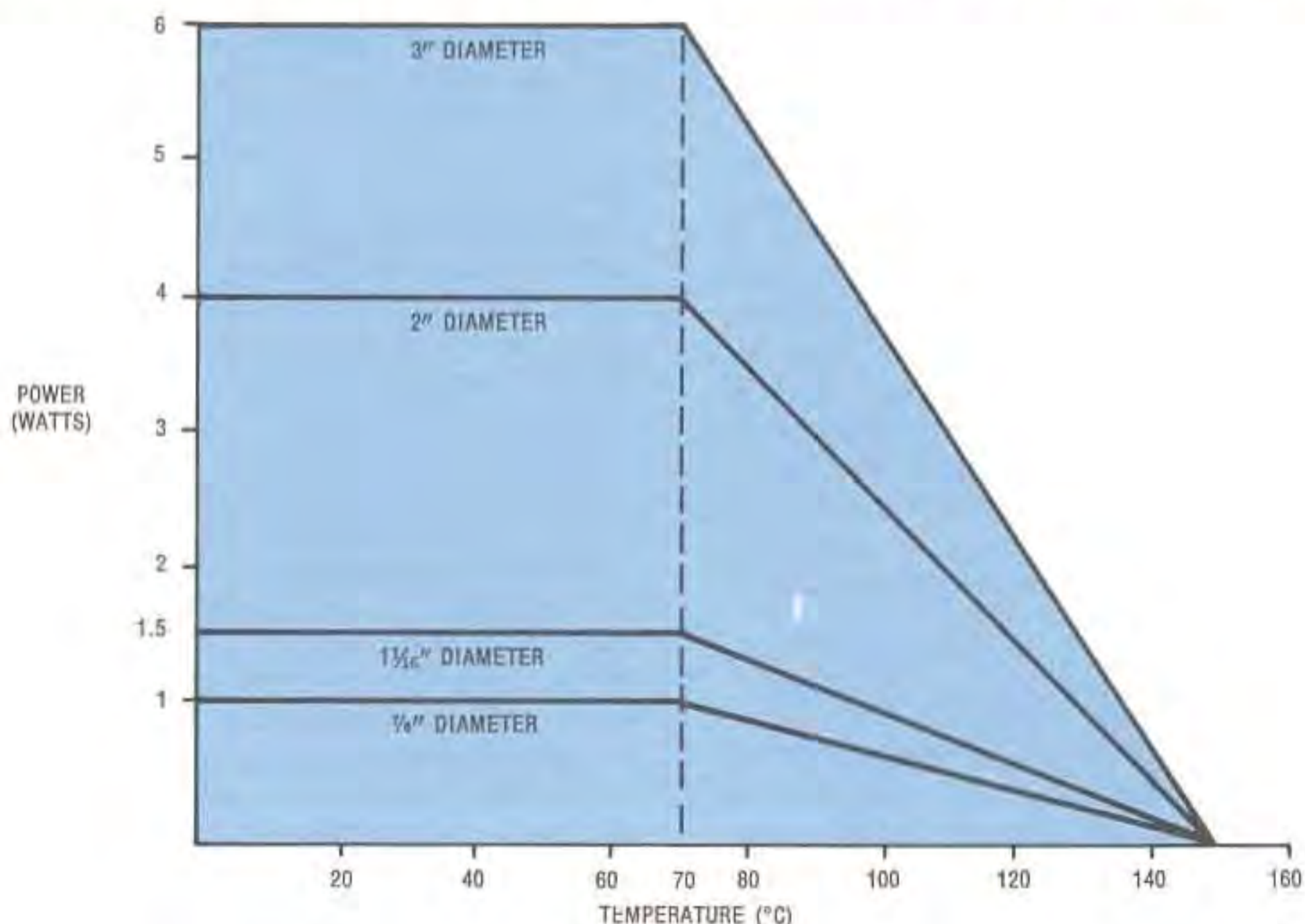
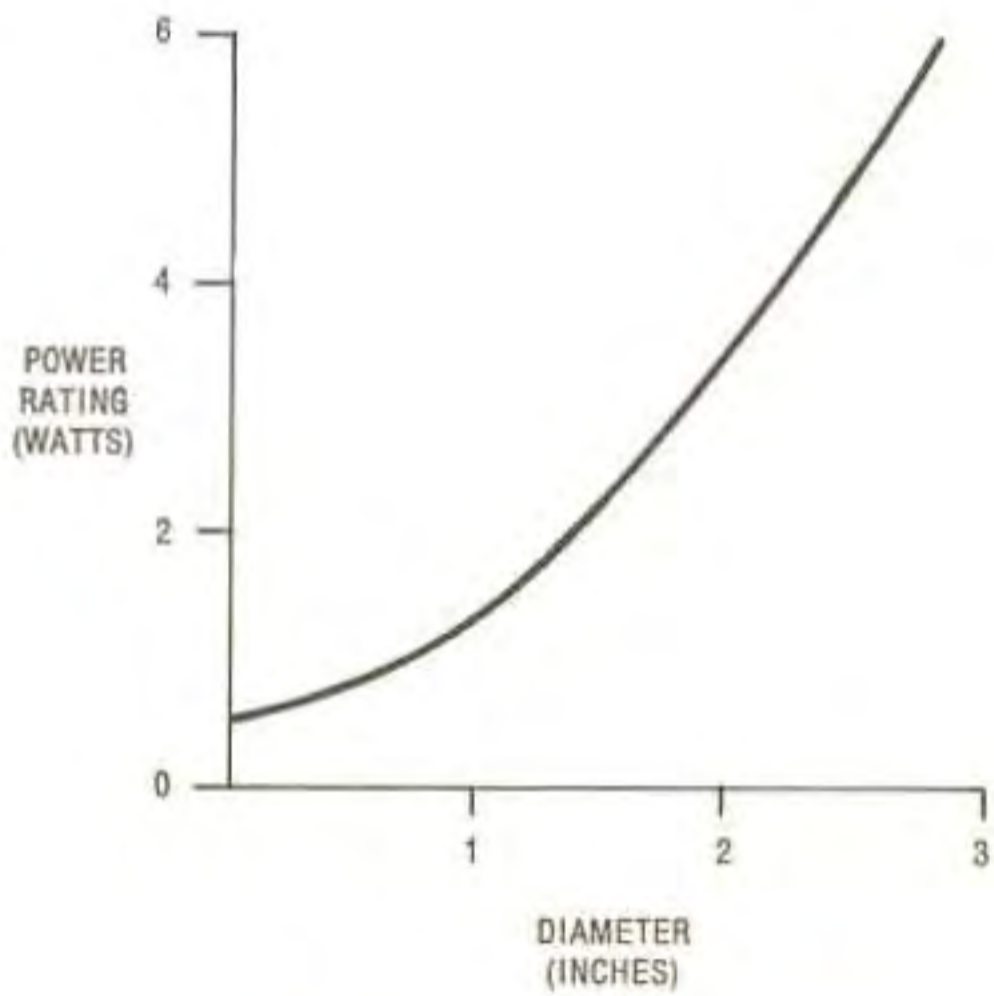
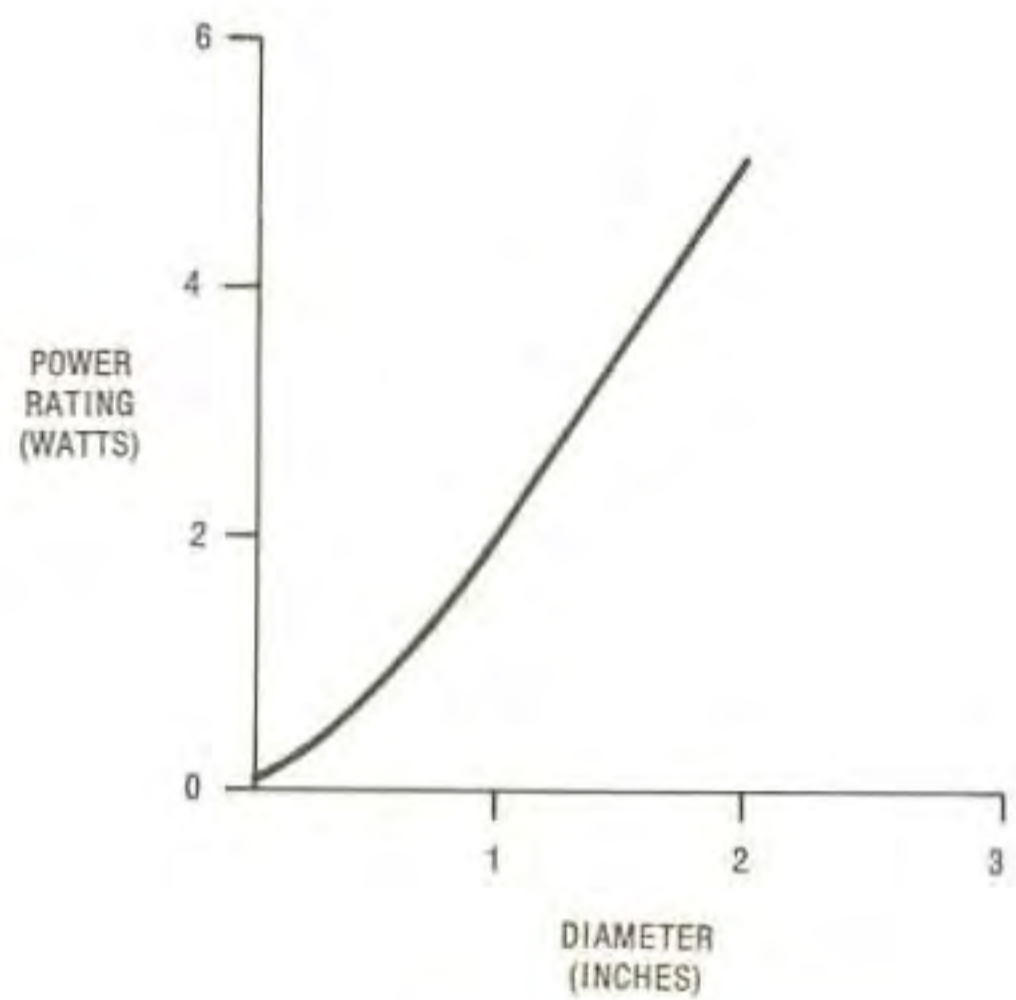

Fig. 6-1 Power derating curves for typical single turn precision potentiometers





A. SINGLE TURNS WITH METALLIC CASE



B. 10 TURNS WITH PLASTIC CASE

Fig. 6-2 Trend in power rating with change in diameter

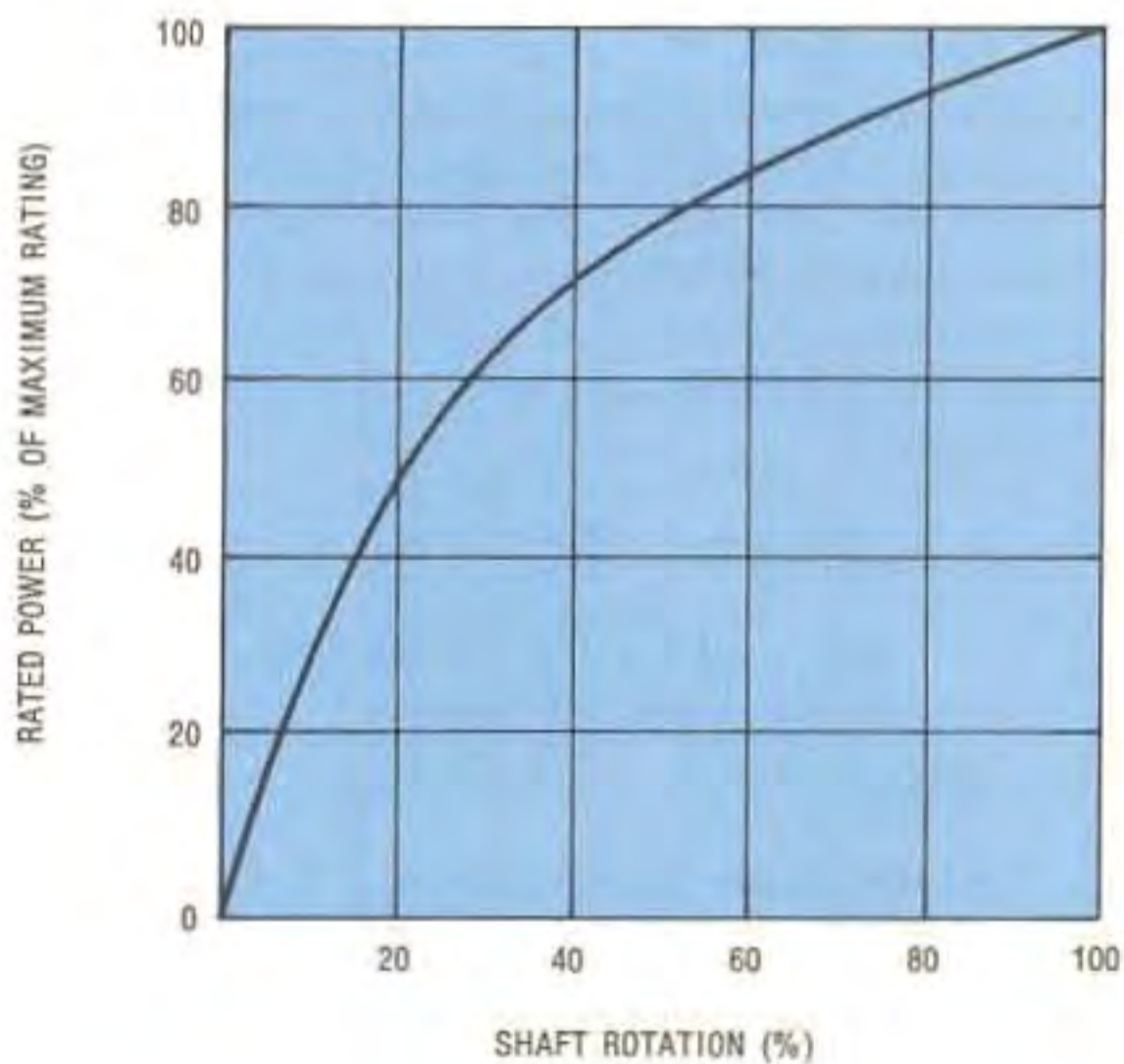

Fig. 6-3 Power derating curve for a rheostat connected, metal case potentiometer

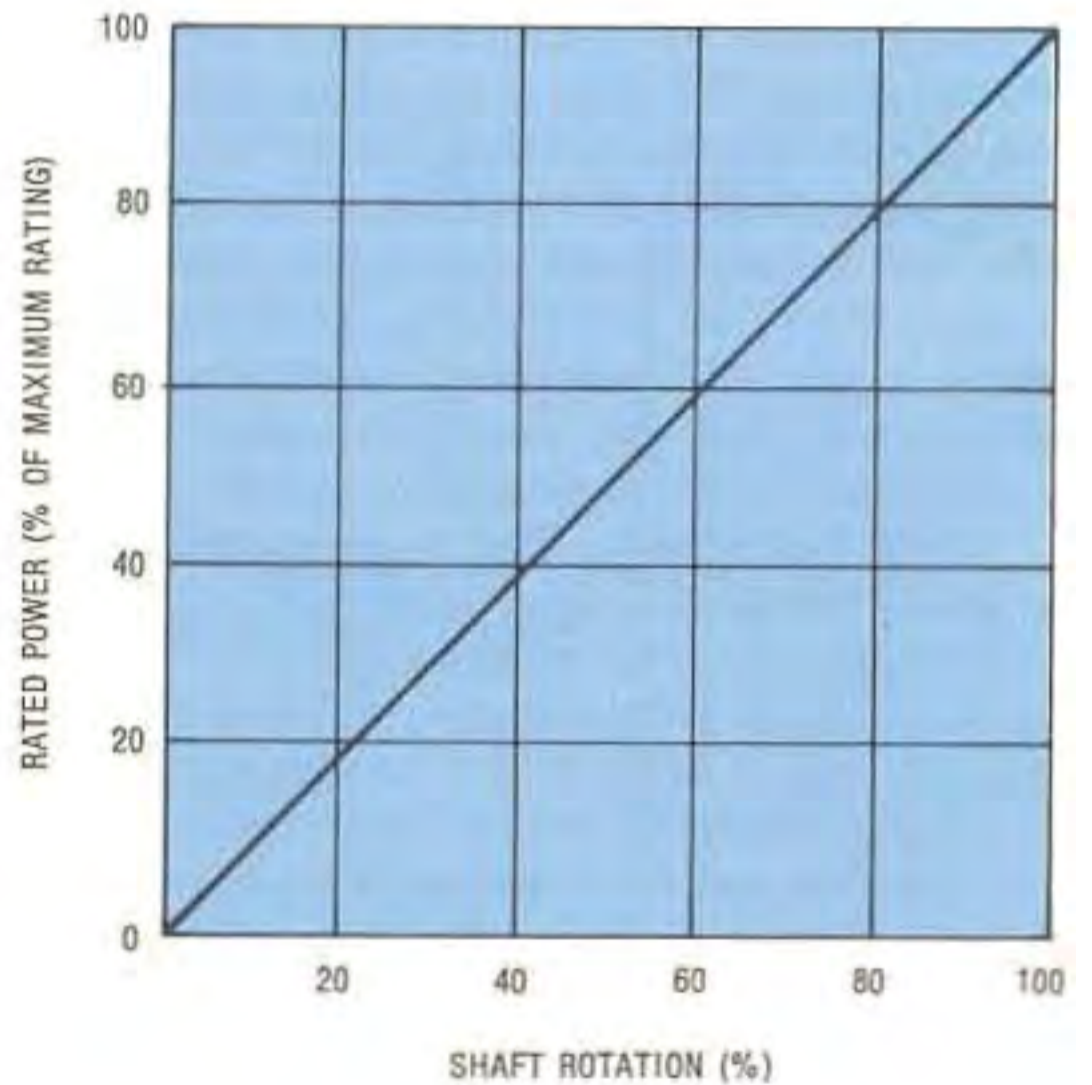

Fig. 6-4 Power derating curve for a rheostat connected, plastic case potentiometer



the poor thermal conductivity of the plastic material, the advantages of cooperative heat dissipation are not enjoyed, and a more linear derating characteristic results.

Continuing advancements in the state of the art (materials and processes) are having a marked effect on the high temperature capabilities of potentiometers. In the past fifteen years, maximum operating temperatures of precision potentiometers have increased from 80°C to 150°C for most devices. Special design considerations have increased some devices to 200°C and higher.

## FREQUENCY CHARACTERISTICS

The resistance element of a wirewound precision potentiometer acts as a pure resistive load for direct current and the common line frequency of 60 Hz. When used in the kilohertz frequency range, the reactances of the distributed inductance and capacitance become significant. When combined with the resistance of the element, these reactances form a complex impedance characteristic load.

The following paragraphs describe four important potentiometer alternating current (ac) parameters: *input impedance*, *output impedance*, *quadrature voltage* and *phase shift*. These parameters are industry standard definitions used to characterize the ac response of potentiometers. Typical values of these parameters are not presented due to the wide range of voltage and frequency possible. In addition, these characteristics vary considerably from design to design due to the well known effects of physical construction and geometry on ac response. They may be applied to any potentiometer, wirewound or non-wirewound, but are most pronounced in units constructed with wirewound elements.

**Input Impedance.** The total impedance (ac reactive and dc resistive) measured between the potentiometer's end terminals is the input impedance. It is always measured with the wiper circuit open (no load). The voltage and frequency at which the impedance is measured must be specified and the wiper must be positioned to a point that results in the largest impedance value.

**Output Impedance.** The total impedance (ac reactive and dc resistive) measured between the potentiometer's wiper terminal and either end terminal is the output impedance. This characteristic is always measured with the end terminals connected together (electrically shorted). As with input impedance, output impedance must be specified together with a voltage and frequency.

**Quadrature Voltage.** When an ac voltage of

sufficiently high frequency is applied as the input voltage to a potentiometer, the resistive element exhibits a characteristic impedance. This impedance is composed of a capacitive reactance  $X'_C$ , inductive reactance  $X'_L$ , and a resistance  $R$ . The reactive components are 180° out of phase and therefore, the larger will cancel the effects of the smaller. The resultant impedance seen by the input voltage (or looking back from the output) will consist of a single reactive component ( $X_C$  or  $X_L$ ) and a resistive component  $R$ . These resultant components can be represented by two vectors in quadrature, i.e., separated in phase by 90°. One is the voltage across the real (resistive) impedance component, the other is across the imaginary (reactive) impedance component. The *quadrature voltage* for a potentiometer refers to that voltage across the reactive component of the output voltage. Fig. 6-5 summarizes the quadrature voltage parameter for a potentiometer whose  $X_L$  is much larger than  $X_C$ .

Fig. 6-6 is the industry standard test circuit for quadrature voltage. In this configuration, a standard potentiometer having a negligible reactive component is used to null the real (resistive) component of output voltage, leaving the reactive voltage displayed on the meter  $M_1$ . The nulling procedure is performed several times until a maximum reading on  $M_1$  is obtained. The quadrature voltage specification for the particular potentiometer being tested is then calculated using the formula given in Fig. 6-6.

**Phase Shift.** The reactive component of the potentiometer's characteristic impedance will cause a *phase shift* between the input and output voltages. The phase shift of a potentiometer refers specifically to sinusoidal inputs. The input frequency, voltage and wiper position must be specified. Mathematically, phase shift may be written:

$$\Phi = \sin^{-1} \frac{E_x}{E_o}$$

( $E_x$  and  $E_o$  must be in like terms, i.e., RMS, Peak, or Average)

Where:

$\Phi$  is the phase shift in degrees.

$E_x$  is the quadrature voltage as measured in Fig. 6-6.

$E_o$  is the output voltage.

A very complicated circuit condition exists if the wiper is connected to a complex impedance load and is allowed to move along the resistance element. The analysis of such a circuit configuration depends critically upon the nature of the external load. The following text assumes that



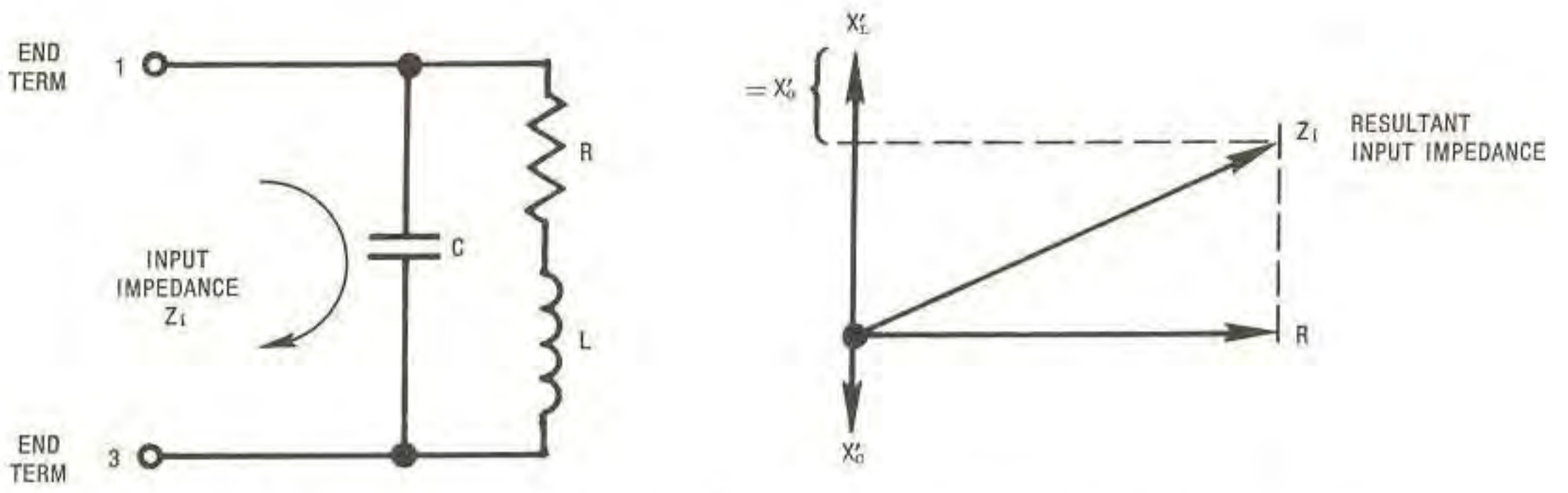

A. RESULTANT INPUT IMPEDANCE FOR THIS UNIT IS EFFECTIVELY INDUCTIVE AND RESISTIVE

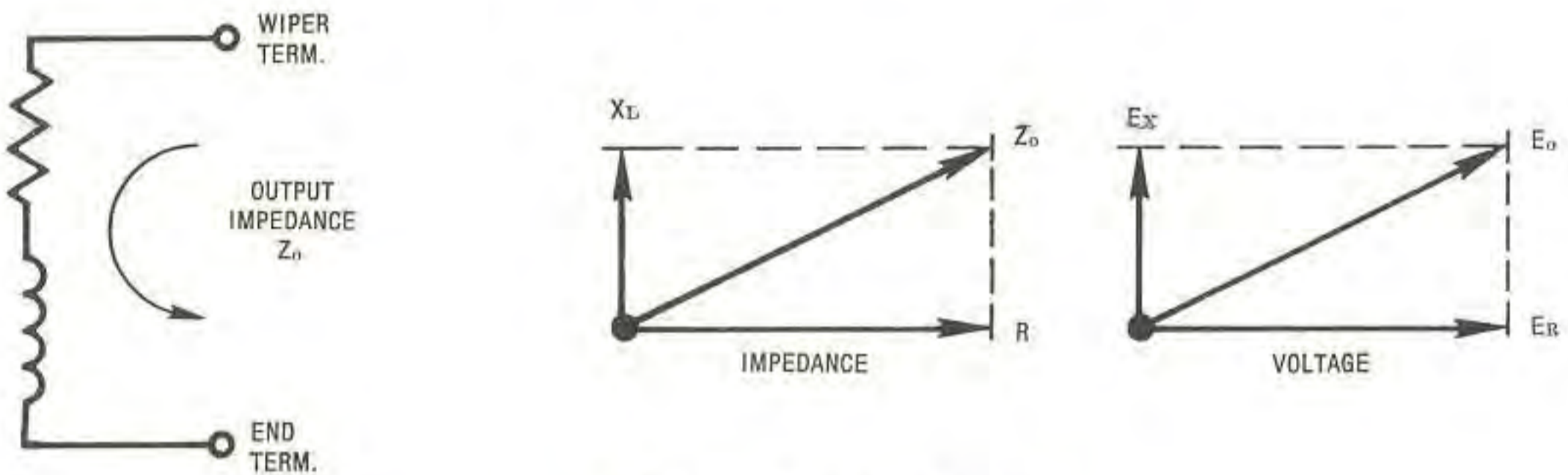

B.  $E_x$  IS THE QUADRATURE VOLTAGE

Fig. 6-5 Quadrature voltage for a particular potentiometer at a specified input voltage and frequency

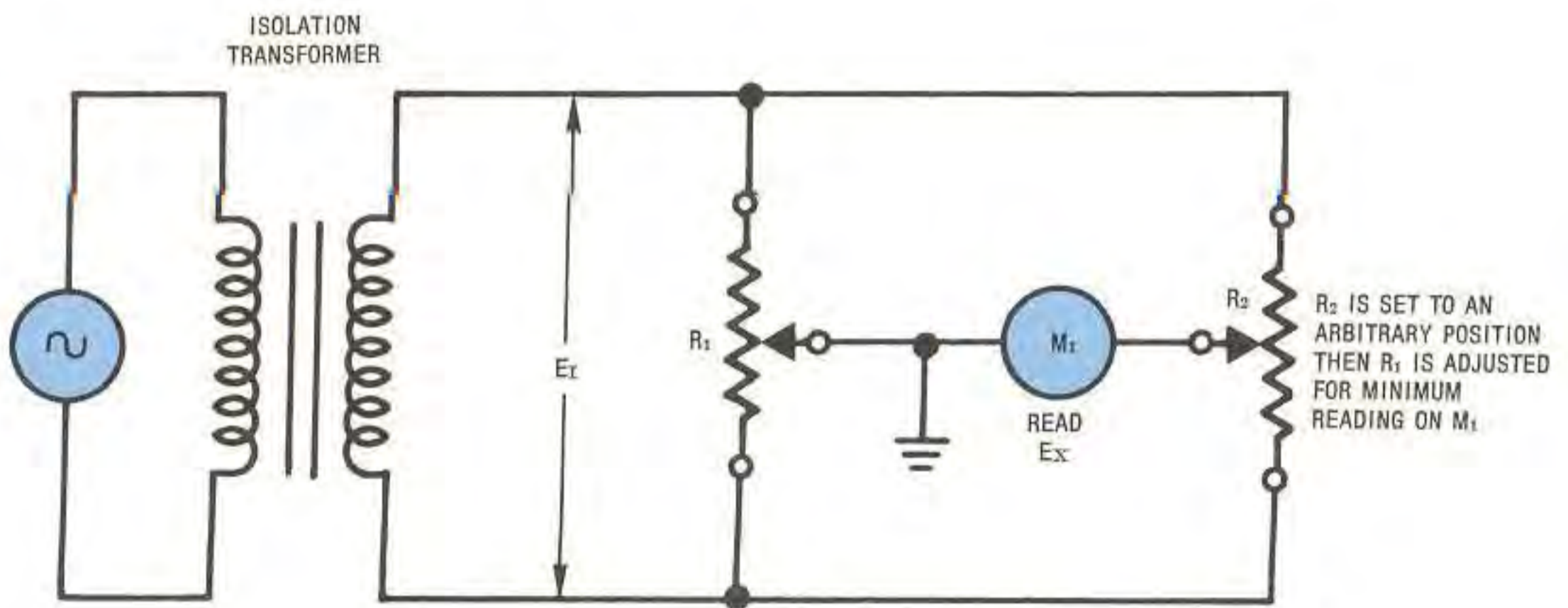

$E_x$  IS THE QUADRATURE VOLTAGE AND IS COMMONLY EXPRESSED IN VOLT/VOLT OF  $E_r$ . MATHEMATICALLY:

$$E_q = \frac{E_x}{E_r}$$

$M_1$  IS A VACUUM TUBE VOLTMETER  
 $R_1$  IS THE STANDARD POTENTIOMETER  
 $R_2$  IS BEING CHECKED FOR QUADRATURE VOLTAGE

Fig. 6-6 Industry standard for quadrature voltage measurement



the wiper is unloaded and set to the low voltage end of the resistive element.

A wirewound resistance element can be analyzed as a uniform transmission line when excited at high frequency. The resistive wire provides the resistance  $R$  of the line and the coiled turns of wire result in inductance  $L$ . Closeness of one winding to the next and winding to case produce capacitance  $C$ . For elements wound on insulated copper mandrel or other conductors there is also capacitance between the mandrel and winding. These three parameters,  $R$ ,  $C$  and  $L$ , are spread along the entire length of resistance wire and are approximated by the equivalent circuit of Fig. 6-7.

For a wirewound potentiometer with conductive mandrel the resistance and inductance of each turn are shown as  $R_w$  and  $L_w$ .  $C_w$  represents capacitance between adjacent turns of wire. Capacitance between winding and housing is identified as  $C_c$ . The capacitive coupling  $C_w$  between individual turns increases when a conductive mandrel is involved. To better understand the total electrical state of a wirewound potentiometer refer again to the lumped parameter circuit of Fig. 6-7. Measurements of an actual potentiometer will yield the most reliable performance data with respect to  $R$ ,  $C$ , and  $L$ .

The use of nonlinear windings, shunt loading, and variable pitch wire spacing can be expected to alter the frequency performance. The use of an enameled copper mandrel to support the resistance winding has been found to lower the potentiometer's frequency range capability.

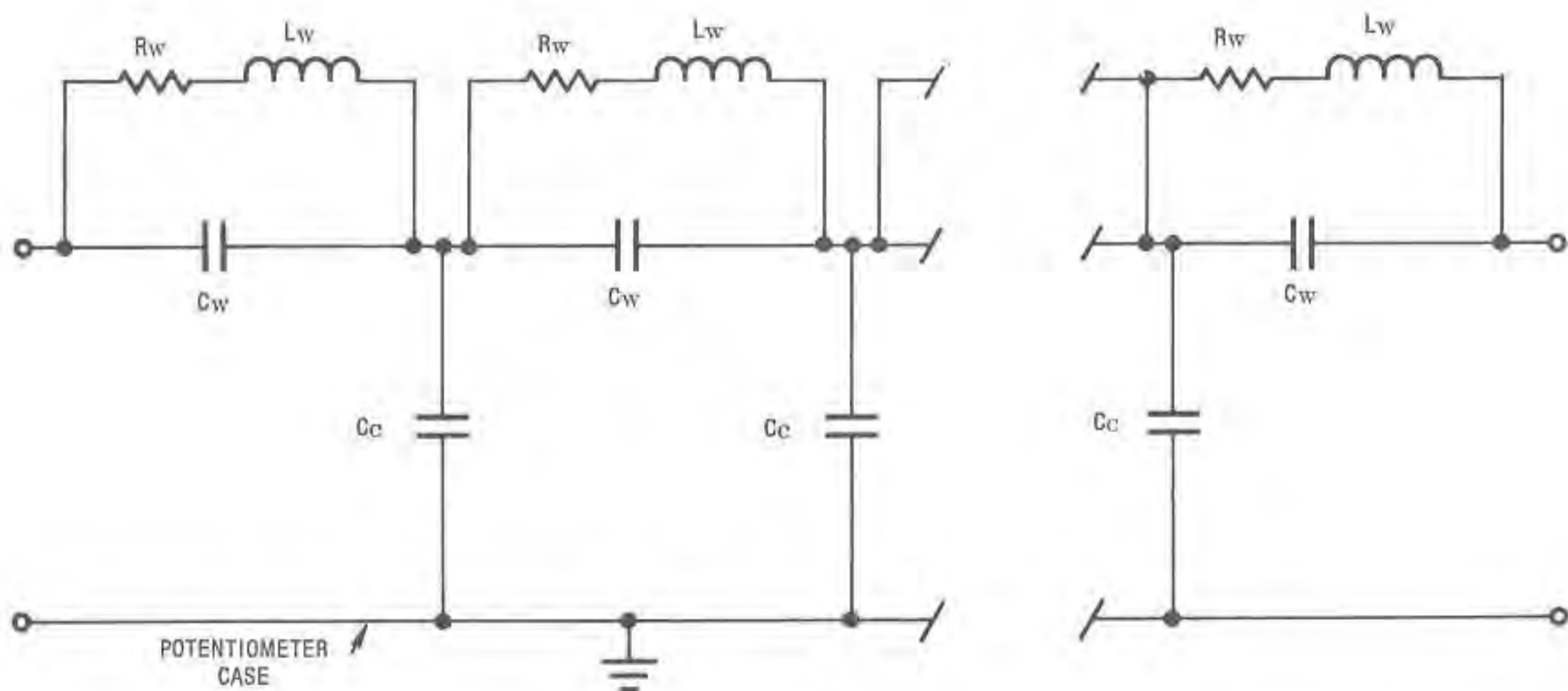

Fig. 6-7 Lumped-parameter approximation for wire wound potentiometers

## LINEAR FUNCTIONS

In this chapter, linear refers to an electrical response rather than a mechanical style. Many of the concepts discussed apply, regardless of mechanical design; but the chapter is dealing with rotary style potentiometers.

A knowledge of the general design characteristics of linear precision potentiometers can help the user in selecting a device that will best satisfy the demands of a particular application. The curves in Fig. 6-8 and Fig. 6-9 are intended to indicate general design trends rather than specific design values.

Fig. 6-8 shows how the range of achievable voltage resolution varies with the potentiometer's diameter. The upper limit of the resolution zone pertains to low values of total resistance (approximately 1,000 ohms). The lower boundary of the resolution zone is for relatively high total resistance (approximately 50K ohms).

Fig. 6-9 illustrates the general trend in linearity with a change in potentiometer diameter. The solid curves represent common linearity figures. The broken line curves represent linearities achievable with special design and construction techniques on potentiometers whose total resistance is 5K ohms or greater.

The concepts of linearity and resolution are related. Certainly the  $1/N$  resolution figure places a limit on the achievable linearity. The linearity deviations are usually from two to five times greater than the  $1/N$  resolution value. Linearity and resolution depend on the value of



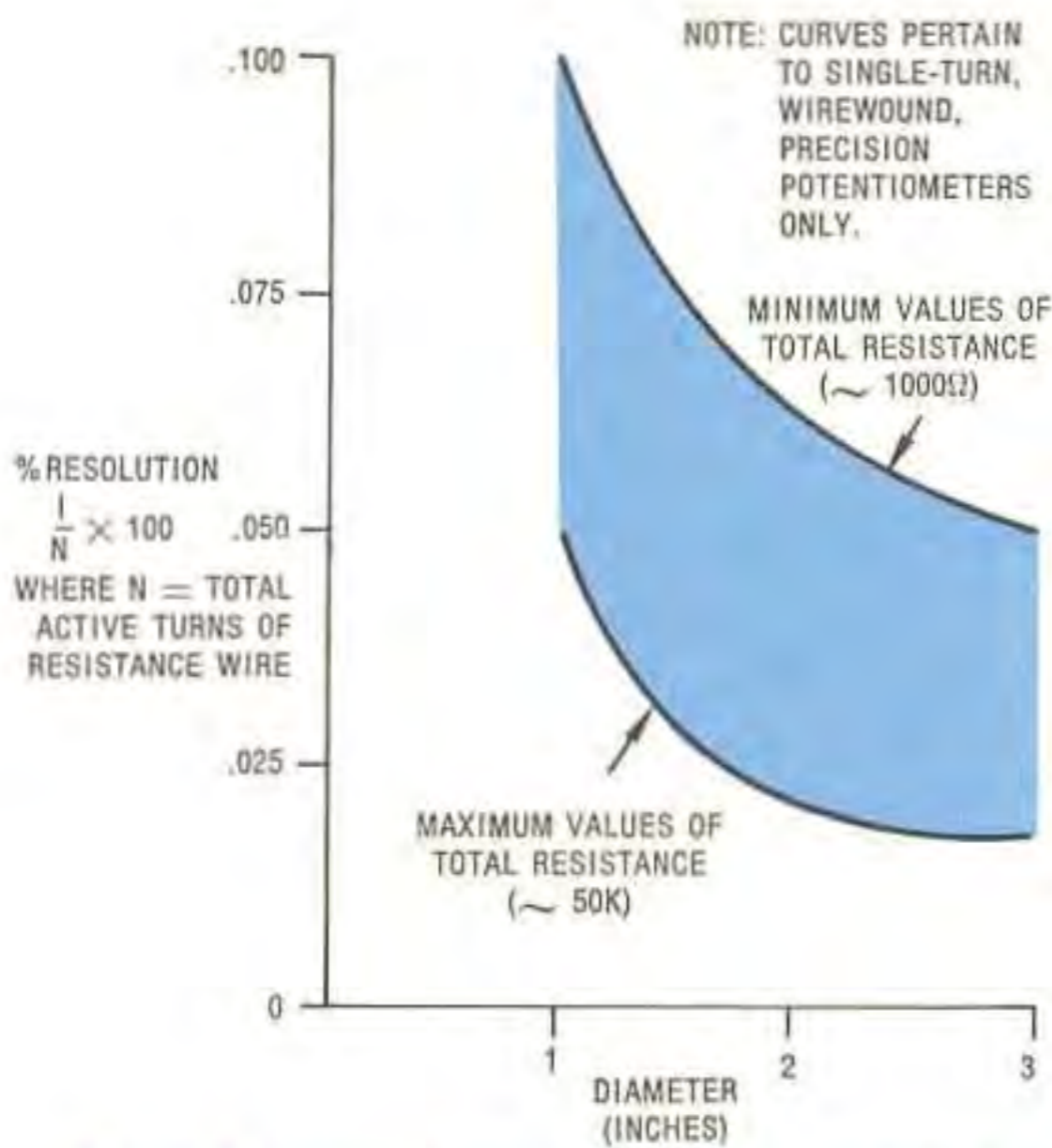

**Fig. 6-8** Trend in resolution with a change in potentiometer diameter

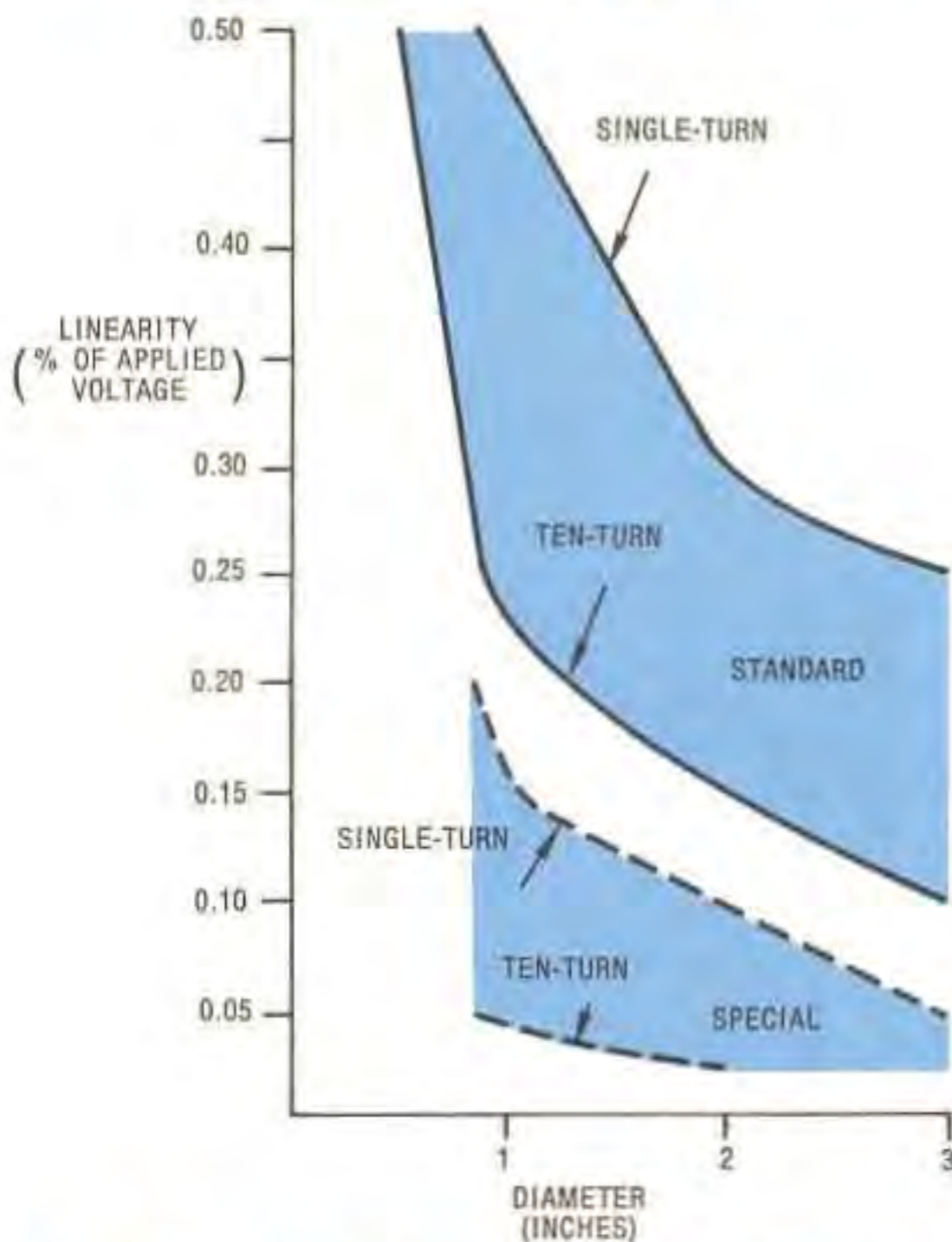

**Fig. 6-9** Trend in potentiometer linearity with a change in diameter

total winding resistance. As winding resistance increases, linearity and resolution improve (decrease).

Any discussion of potentiometer electrical functions is not complete without stressing the interdependence of the accuracy and the

methods of resistive element construction. The construction of resistive elements is discussed in detail in Chapter 7. The following list outlines those construction factors which influence the accuracy of the assembled wirewound potentiometer:

1. The uniformity of the supporting mandrel.
2. The tension of the resistance wire.
3. The spacing and number of turns of resistance wire.
4. The degree of cleanliness of the resistance element.
5. The concentricity of the mounted winding relative to the rotational axis of the wiper.

The angular length of a linear resistance winding for a single turn potentiometer is usually about  $350^\circ$ . For special applications, this angle can be reduced. By careful construction, the winding can be made to accommodate more than  $350^\circ$  of wiper rotation. Obviously, it would be undesirable to short circuit the two ends of the resistance windings; but it is possible to place the two ends of the resistance element in proximity and still control the design such that the wiper will not bridge the gap between the ends. When such precaution is taken, the potentiometer is described as *non-shorting*.

For some special applications, such as the sine/cosine functions presented in the next section, it may be desirable to rotate the slider continuously to produce a repetitive voltage waveform. In such instances, the two ends of the resistance winding are joined together. Other forms of continuous winding are discussed in later sections of this chapter.

## NONLINEAR FUNCTIONS

The accuracy with which a nonlinear function can be produced is difficult to generalize because of the many controlling factors and the variety in design approaches available to the potentiometer designer. The following paragraphs will explain some of the nonlinear techniques available. Expecting certain variations to occur in manufacture, the potentiometer designer usually designs within a band that is equal to one-third the required conformity band. This conservative approach gives assurance that the final performance will be well within the conformity specification.

To create workable specifications the user should be aware of the producibility of a given nonlinear function, the minimum size into which it can be built, the ease of manufacturing a large quantity with a minimum of production difficulty, and the cost. The table in Fig. 6-10 shows the common nonlinear functions available from most manufacturers. It is important to note the



THE POTENTIOMETER HANDBOOK

	FUNCTION DESCRIPTION	SPECIFICATIONS	CONDUCTIVE PLASTIC SINGLE TURN			
			3/8" DIAMETER	1 1/16" DIAMETER	2" DIAMETER	
<b>SIN-COS 360°</b> 		$\frac{e_1}{E} = \sin(\alpha)$ $\frac{e_2}{E} = \cos(\alpha)$ $0^\circ \leq \alpha \leq 360^\circ$ $0^\circ \leq \theta \leq \theta_T$	Resistance Range $\Omega$ Conformity (1) Std. $\pm\%$ Best $\theta_T$	1K-50K 60K 2.0 2.5 1.0 1.25 360°	1K-50K 60K-75K 1.25 1.5 0.5 0.75 360°	1K-50K 60K-100K 1.0 1.25 0.25 0.3 360°
<b>SINE 360°</b> 		$\frac{e}{E} = \sin(\alpha)$ $0^\circ \leq \alpha \leq 360^\circ$ $0^\circ \leq \theta \leq \theta_T$	Resistance Range $\Omega$ Conformity (1) Std. $\pm\%$ Best $\theta_T$	1K-50K 60K 2.0 2.5 1.0 1.25 360°	1K-50K 60K-75K 1.25 1.5 0.5 0.75 360°	1K-50K 60K-100K 1.0 1.25 0.25 0.3 360°
<b>COSINE 360°</b> 		$\frac{e}{E} = \cos(\alpha)$ $0^\circ \leq \alpha \leq 360^\circ$ $0^\circ \leq \theta \leq \theta_T$	Resistance Range $\Omega$ Conformity (1) Std. $\pm\%$ Best $\theta_T$	1K-50K 60K 2.0 2.5 1.0 1.25 360°	1K-50K 60K-75K 1.25 1.5 0.5 0.75 360°	1K-50K 60K-100K 1.0 1.25 0.25 0.3 360°
<b>SINE 180°</b> 		$\frac{e}{E} = \sin(\alpha)$ $0^\circ \leq \alpha \leq 180^\circ$ $0^\circ \leq \theta \leq \theta_T$	Resistance Range $\Omega$ Conformity (1) Std. $\pm\%$ Best $\theta_T$	1K-50K 2.0 1.0 360°	1K-50K 1.25 0.75 360°	1K-50K 1.0 0.5 360°
<b>COSINE 180°</b> 		$\frac{e}{E} = \cos(\alpha)$ $0^\circ \leq \alpha \leq 180^\circ$ $0^\circ \leq \theta \leq \theta_T$	Resistance Range $\Omega$ Conformity (1) Std. $\pm\%$ Best $\theta_T$	1K-100K 2.0 1.0 320°	1K-100K 1.25 0.5 340°	1K-100K 1.0 0.25 350°
<b>SINE 90°</b> 		$\frac{e}{E} = \sin(\alpha)$ $0^\circ \leq \alpha \leq 90^\circ$ $0^\circ \leq \theta \leq \theta_T$	Resistance Range $\Omega$ Conformity (1) Std. $\pm\%$ Best $\theta_T$	1K-100K 1.7 1.0 320°	1K-100K 1.25 0.5 340°	1K-100K 0.75 0.25 350°
<b>COSINE 90°</b> 		$\frac{e}{E} = \cos(\alpha)$ $0^\circ \leq \alpha \leq 90^\circ$ $0^\circ \leq \theta \leq \theta_T$	Resistance Range $\Omega$ Conformity (1) Std. $\pm\%$ Best $\theta_T$	1K-100K 1.7 1.0 320°	1K-100K 1.25 0.5 340°	1K-100K 0.75 0.25 350°
<b>SINGLE SIDED SQUARE</b> 		$\frac{e}{E} = X^2$ $0 \leq X \leq 1$ $0^\circ \leq \theta \leq \theta_T$	Resistance Range $\Omega$ Conformity (1) Std. $\pm\%$ Best $\theta_T$	1K-50K 1.25 1.0 320°	1K-75K 1.0 0.5 340°	1K-100K 0.6 0.25 350°
<b>DOUBLE SIDED SQUARE</b> 		$\frac{e}{E} = X^2$ $-1 \leq X \leq +1$ $-\theta_T \leq \theta \leq +\theta_T$	Resistance Range $\Omega$ Conformity (1) Std. $\pm\%$ Best $\theta_T$	1K-50K 2.0 1.0 $\pm 180^\circ$	1K-50K 1.25 0.75 $\pm 180^\circ$	1K-50K 1.0 0.5 $\pm 180^\circ$
<b>20 db LOG</b> 		$\frac{e}{E} = 10^{(x-1)}$ $0 \leq X \leq 1$ $0^\circ \leq \theta \leq \theta_T$	Resistance Range $\Omega$ Conformity (1) Std. $\pm\%$ Best $\theta_T$	1K-75K 1.25 0.75 320°	1K-100K 1.0 0.5 340°	1K-150K 0.6 0.5 350°
<b>40 db LOG</b> 		$\frac{e}{E} = 10^{2(x-1)}$ $0 \leq X \leq 1$ $0^\circ \leq \theta \leq \theta_T$	Resistance Range $\Omega$ Conformity (1) Std. $\pm\%$ Best $\theta_T$	1K-50K 3.0 2.0 320°	1K-100K 2.0 1.0 340°	1K-100K 1.0 0.75 350°

Fig. 6-10 Standard nonlinear functions



## APPLICATION AS A PRECISION DEVICE

WIREWOUND SINGLE TURN				3/8" DIAMETER WIREWOUND MULTITURN									
3/8" DIAMETER		1 1/8" DIAMETER		2" DIAMETER		3" DIAMETER		3 TURN		5 TURN		10 TURN	
N/A	N/A	N/A	N/A	250	16K	250	30K	N/A	N/A	N/A	N/A	N/A	N/A
N/A	N/A	N/A	N/A	1.0	1.0	1.0	0.5	N/A	N/A	N/A	N/A	N/A	N/A
N/A	N/A	N/A	N/A	0.6	0.4	0.5	0.25	N/A	N/A	N/A	N/A	N/A	N/A
				360°		360°							
250	4K	250	5K	250	16K	250	30K	500	7K	1K	12K	1K	25K
2.0	1.5	1.5	1.0	1.0	1.0	1.0	0.5	1.0	1.0	0.8	0.8	0.7	0.7
1.1	0.9	1.0	0.75	0.6	0.4	0.5	0.25	0.7	0.5	0.5	0.35	0.25	0.2
				360°		360°		1080°		1800°		3600°	
250	4K	250	5K	250	16K	250	30K	500	7K	1K	12K	1K	25K
2.0	1.5	1.5	1.0	1.0	1.0	1.0	0.5	1.0	1.0	0.8	0.8	0.7	0.7
1.1	0.9	1.0	0.75	0.6	0.4	0.5	0.25	0.7	0.5	0.5	0.35	0.25	0.2
				360°		360°		1080°		1800°		3600°	
250	4K	250	5K	250	16K	250	30K	500	8K	500	14K	1K	25K
1.8	1.5	1.5	1.25	1.5	1.1	1.25	1.0	1.5	1.1	1.2	1.0	1.1	0.9
1.1	0.9	1.1	0.9	0.6	0.4	0.5	0.25	0.6	0.5	0.5	0.35	0.25	0.2
				360°		360°		1080°		1800°		3600°	
500	15K	500	18K	500	75K	500	125K	1K	25K	1K	45K	1K	100K
1.8	1.5	1.5	1.0	1.0	1.0	0.75	0.5	1.0	1.0	0.8	0.8	0.7	0.7
1.1	0.9	1.0	0.8	0.6	0.4	0.4	0.25	0.7	0.6	0.5	0.4	0.3	0.2
				350°		350°		1080°		1800°		3600°	
1K	13K	1K	18K	1K	75K	1K	125K	1K	25K	1K	45K	1K	100K
1.6	1.3	1.5	1.2	1.0	0.9	1.0	0.9	1.2	1.0	1.0	1.0	1.0	1.0
0.6	0.5	0.5	0.4	0.4	0.2	0.35	0.2	0.4	0.3	0.25	0.2	0.2	0.15
				350°		350°		1080°		1800°		3600°	
1K	13K	1K	18K	1K	75K	1K	125K	1K	25K	1K	45K	1K	100K
1.6	1.3	1.5	1.2	1.0	0.9	1.0	0.9	1.2	1.0	1.0	1.0	1.0	1.0
0.6	0.5	0.5	0.4	0.4	0.2	0.35	0.2	0.4	0.3	0.25	0.2	0.2	0.15
				350°		350°		1080°		1800°		3600°	
1K	13K	1K	18K	1K	50K	1K	100K	1K	20K	1K	35K	1K	70K
1.5	1.0	1.2	1.0	1.0	0.5	0.6	0.4	0.9	0.5	0.8	0.5	0.7	0.5
0.7	0.6	0.65	0.5	0.4	0.25	0.3	0.15	0.5	0.35	0.3	0.2	0.2	0.15
				350°		350°		1080°		1800°		3600°	
250	3.5K	250	4K	500	13K	500	25K	500	7K	500	8K	1K	20K
1.8	1.5	1.7	1.3	1.2	1.0	1.0	0.75	1.2	1.2	1.1	1.1	1.0	1.0
1.4	1.0	1.2	1.0	0.65	0.45	0.5	0.25	0.75	0.65	0.5	0.4	0.3	0.25
				±180°		±180°		±540°		±900°		±1800°	
1K	12K	1K	14K	1K	50K	1K	75K	1K	20K	1K	33K	1K	70K
1.5	1.0	1.2	1.0	0.75	0.75	0.75	0.5	0.75	0.75	0.65	0.65	0.5	0.5
0.8	0.7	0.7	0.6	0.5	0.3	0.5	0.15	0.45	0.35	0.35	0.25	0.2	0.15
				350°		350°		1080°		1800°		3600°	
500	5K	500	7K	1K	25K	1K	40K	1K	10K	1K	16K	1K	35K
2.5	2.0	2.0	1.75	1.5	1.2	0.8	0.75	1.2	1.2	1.1	1.1	1.0	1.0
1.5	1.2	1.4	1.1	0.7	0.45	0.5	0.25	0.75	0.65	0.5	0.4	0.35	0.3
				350°		350°		1080°		1800°		3600°	

NOTES: (1) All conformities listed are peak-to-peak conformities, i.e., the absolute difference between the maximum and minimum voltage applied.

(2) e = Output Voltage E = Total Applied Voltage  $\theta$  = Shaft Position  $\theta_T$  = Theoretical Travel  $X = \theta \div \theta_T$



relationship between size, total resistance range, and conformity tolerances for each of these common functions. Many other nonlinear functions can be achieved. To order special functions, supply the potentiometer manufacturer a mathematical equation representing the function or a series of data points and a graphical representation of the desired function.

It is possible to make an estimation of the resolution achievable for a given nonlinear function with a wirewound potentiometer. Approximate portions of the function by straight line segments and estimate the resolution as though these linear segments were part of a continuous linear potentiometer. In the case of linear potentiometers, it is possible to use wire size, resistivity, and spacing to minimize the  $1/N$  resolution. However, it is usually not possible to achieve as low a  $1/N$  resolution figure for a similar linear portion of a nonlinear potentiometer due to other design factors. The following method will give an approximate resolution figure:

1. Plot a curve of percent voltage (or percent resistance) vs. percent rotation.
2. Approximate the nonlinear curve with joined straight-line segments.
3. Measure the approximate slope of a linear segment occupying a given region of the function.
4. Specify the desired total resistance of the nonlinear potentiometer.
5. Construct a resolution curve for a linear potentiometer of the same size, type of construction, and total resistance using data from a manufacturer's catalog sheet. Read the approximate  $1/N$  resolution for the region of the function under consideration.

As might be expected, this method yields small  $1/N$  resolution values in the regions of relatively high slope. This is because higher slopes require a greater number of turns of fine, high resistance wire.

**Loading.** There are two methods of generating nonlinear functions by loading. They are:

- Shunt loading the resistive element.
- Shunt loading the wiper.

The principal feature of shunt loading techniques is its flexibility.

**Loading the Resistive Element.** If the wirewound element is constructed with several taps, a variety of nonlinear curves can be approximated by connecting the appropriate shunt resistors. The element taps are usually accessible via terminals on the potentiometer case. The resistance element is excited by a voltage applied across the end terminals. The resistivity, and therefore the output function, may be different in various portions of the element depending on the values of fixed shunt resistors across each

section as selected by the system designer. This technique has considerable benefit to the potentiometer user and manufacturer because of its versatility.

When the nonlinear function requirement is precisely defined *before* potentiometer construction, the manufacturer can supply a unit complete with shunt resistors for optimization of the electrical function. Potentiometers can be designed so shunt resistors can be attached internally or externally.

Some users maintain a stock of tapped potentiometers that they can quickly shunt to provide a variety of custom nonlinear functions. In this case, the exact nonlinear function is unknown when it is ordered but a linear potentiometer is specified with taps at selected locations. The user can then attach external shunt resistors that produce the desired function.

**Loading the Wiper.** In Chapter 3, output error due to wiper circuit loading was presented in detail. In certain precision potentiometer applications, this error may be used to an advantage. By proper selection of the load, the output can be shaped to vary (the error) in some desired nonlinear manner. Fig. 6-11 shows a schematic example. Proper selection of the shunt-to-element total resistance ratio can produce smooth nonlinear functions such as tangent, secant, square root, square, and reciprocal. Fig. 6-12 illustrates a possible nonlinear function with a loaded wiper circuit.

Anytime current is caused to flow through

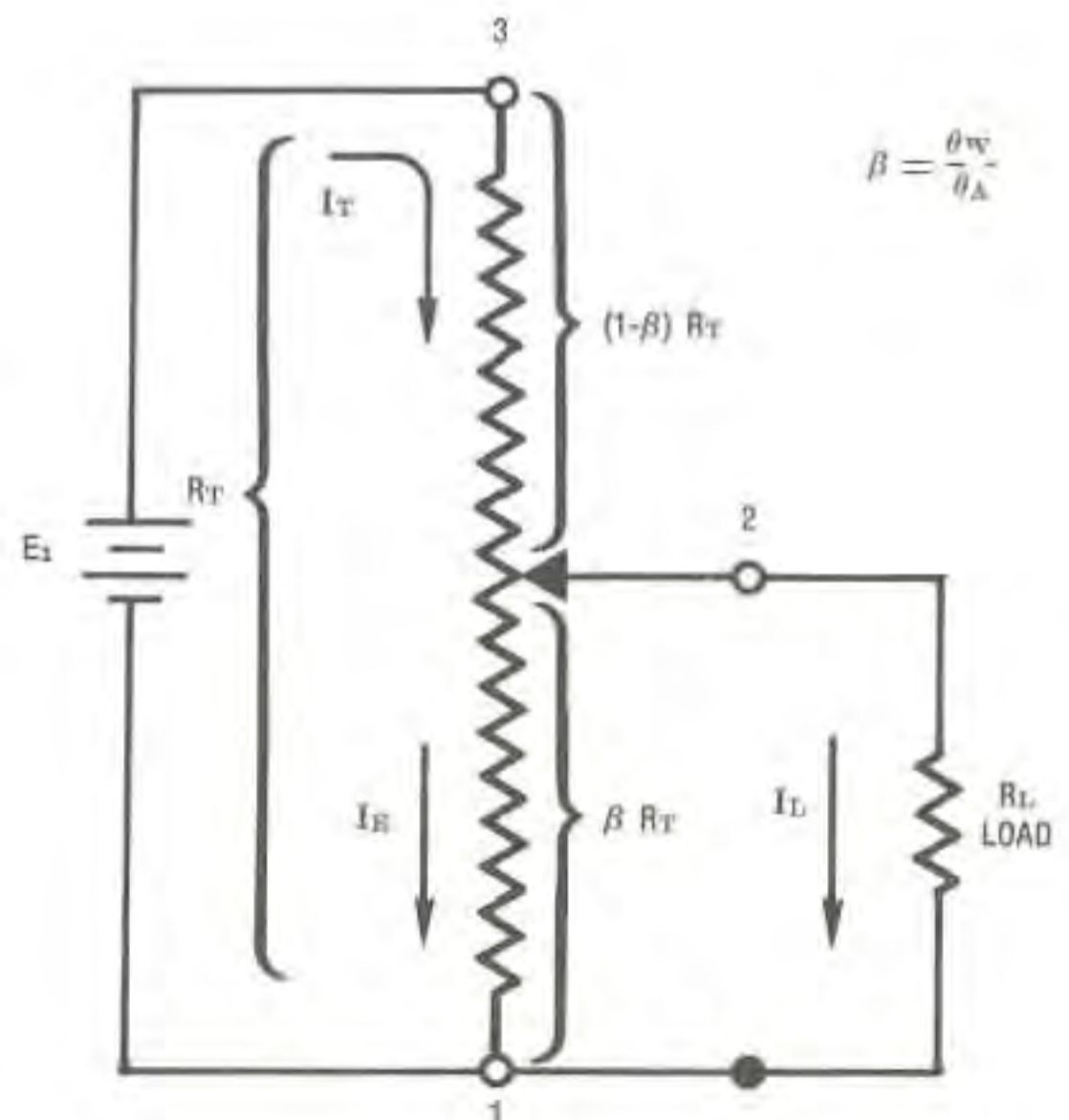
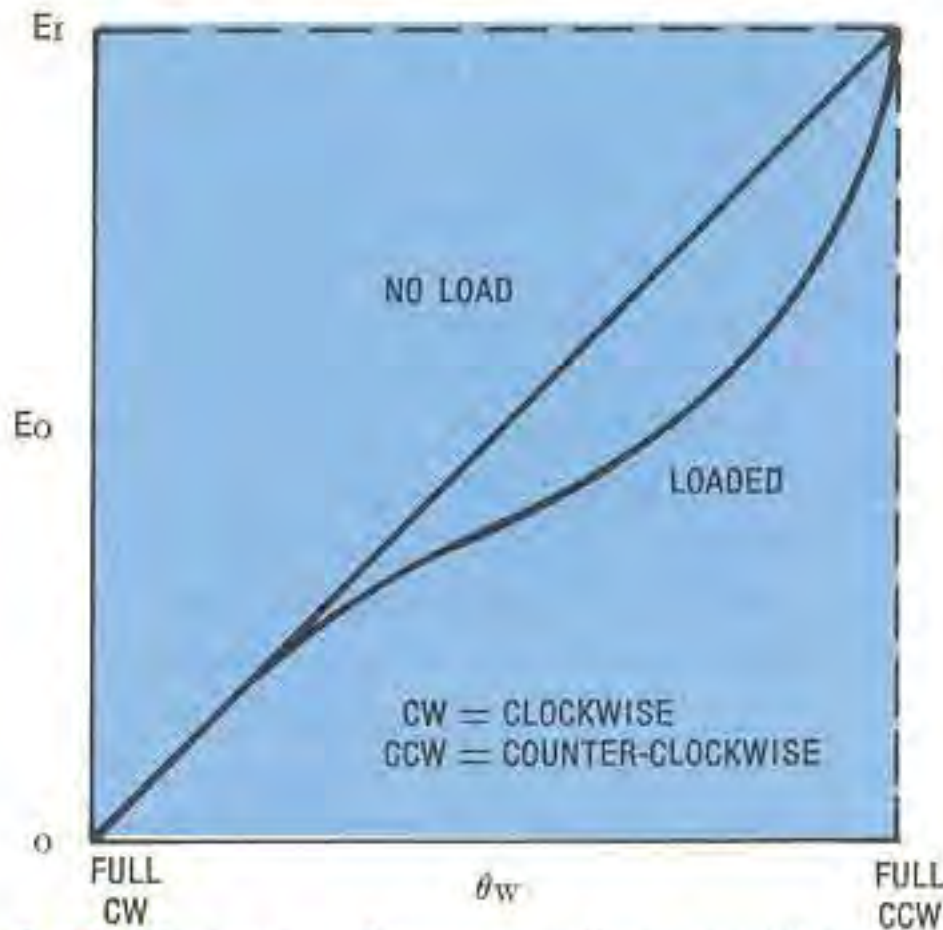

Fig. 6-11 A potentiometer with a loaded wiper circuit





**Fig. 6-12** Output voltage vs wiper position with and without wiper load

the wiper, special care must be taken. Every potentiometer has a maximum wiper current that it is capable of handling without degrading its operational life. Consult the manufacturer's data sheet or the manufacturer directly to determine maximum wiper current capability.

If a particular application requires the wiper to be loaded to a degree which causes excessive nonlinearity, then some type of compensation will be necessary. Chapter 3 discusses some com-

pensation methods. Another method utilizes an isolation amplifier inserted in the circuit between the wiper and the load. The high input impedance of the isolation amplifier draws negligible wiper current.

Compensation can also be affected by the use of a loaded linear potentiometer. The resistance element is compensated — made nonlinear — during manufacture to correct the loading effect. Given the resistance value of the load, the potentiometer manufacturer can calculate the deviation from the theoretical function. This information is then used to manufacture a compensated element.

**Voltage Clamping.** Another technique for obtaining nonlinear functions from linear element potentiometers involves clamping (electrically holding) various taps at the *voltage levels* of the desired function. This technique is shown in Fig. 6-13. End terminals or tap points are connected to a voltage divider. If the voltage divider is of sufficiently low resistance relative to the potentiometer element, each of the tap points can be set independently.

The result is an approximation of the desired function by straight-line segments. When approximating a nonlinear function by voltage clamping, the clamping voltages are generally established with the wiper circuit load connected. This provides compensation of loading errors and

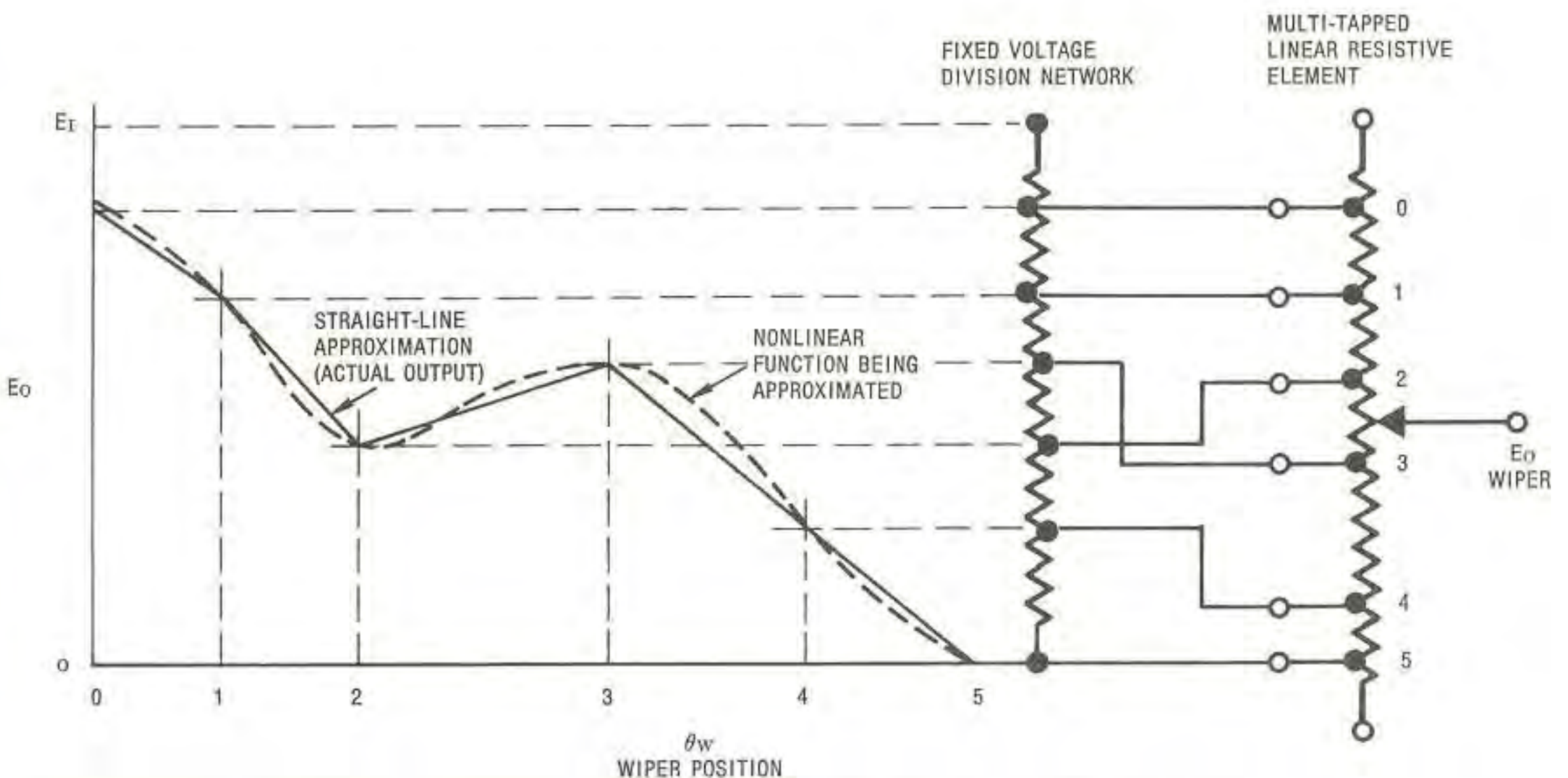

**Fig. 6-13** Use of voltage clamping to obtain a straight-line approximation of a nonlinear function



assures function coincidence at the tap points. If the wiper is loaded by a low impedance circuit, the straight-line segments may sag between the tap points. This effect can be compensated by setting the clamping voltage slightly above the theoretical tap point values.

Nonlinear functions with steep slopes require many taps if a high degree of accuracy is desired. These steep slopes must have adequate power rating to dissipate the heat resulting from the voltage drop at established resistance levels. The steepest slope, the number of taps in this slope and the power rating of the entire resistance element must be considered when determining the output voltage scale.

Split windings can be used if small irregularities (flats) in the output are permissible. For this construction, pairs of taps are used to terminate isolated lengths of resistance element. Very steep slopes are practical when these sections are connected to proper voltage sources.

Voltage clamping provides versatility and also offers the advantage of not requiring a precision linear resistance element. The small flats in the output curve at each tap may be a limitation for some applications. For this reason, the distance between taps are of concern. The cause of flats in the output curve is the effect of the wiper contacting more than one turn of wire on each side of the tap at the same time it touches the tap.

**Cascaded, Ganged Linear.** Nonlinear functions with extremely steep slopes can be made using ganged, linear potentiometers. This is done by connecting the potentiometers in series (cascading) with the wiper output of one providing the excitation voltage for the next. The precision of such an arrangement depends on just how close a mathematical power series expansion can approximate the desired nonlinear function. Use of poly-nominal curve fitting methods will usually result in satisfactory power series.

When applications require various functions relative to shaft rotation, the ganged network may be used. Some of these relationships can be achieved with nonlinear potentiometers or shunting techniques. Then the power series expansion with appropriate resistors can be supplemented with nonlinear terms.

Potentiometer loading characteristics, discussed earlier, can be used to develop nonlinear functions. Complex loading characteristics result from series ganged potentiometers. By careful selection of resistances, nonlinear functions can be approximated. The required design procedure, especially in situations with polarity changes between terms of the initial power series, is often complex and prohibitive. Functions with low order power series can occasionally be designed by

overlooking the effects of loading and then using summation network design to compensate. Calculations and empirical methods are used to determine the values of the summing resistors to obtain the necessary correction factors.

Designing the ganged arrangement using conventional network synthesis techniques results in a more versatile method of determining component values in the network. The ganged circuit can be handled as a two element network simply by setting some limitations on its characteristic polynomial. A longer trial and error method can be avoided if the above conditions can be met for a specific application. Then, using RL transfer function techniques, the ganged circuit and weighing network can be designed.

## VOLTAGE TRACKING ERROR

Voltage tracking error is the difference between the actual output voltages of commonly actuated (i.e., common shaft) potentiometers at any point within their total electrical travel. It is expressed as a percentage of the total voltage applied. Tracking is a conformity specification that compares the outputs of ganged units. Tracking error is checked continuously by rotating the shaft at a slow, constant speed and recording the difference in voltage between each section and a reference section. No angle of rotation scale is used.

In a typical tracking application, the shaft is positioned by the output voltage, unlike the case where the application requires that the potentiometer shaft be positioned by gearing from some outside control. The most precise conformity in the outputs can be obtained by means of a tracking arrangement. Instead of trying to achieve simultaneous terminal conformity between the geared potentiometers or by checking each section against a theoretical angle scale, tracking compares the output voltage of one section with the output of each other section and uses the difference to describe simultaneous conformity between the outputs of the ganged sections. The voltage difference signal drives the potentiometer by means of a motor and gear linkage. The other sections then provide outputs that track the reference section with extremely high conformity due to the matching of error curves. Tracking error will always be less than the sum of the terminal conformities of each section. Where manufacturers' techniques permit combination of nonwirewound and wirewound sections on the same shaft, it is possible to gain the particular advantages of each type in the various sections.

The accuracy of a tracking potentiometer is inherent in its design and construction. A ganged combination, built to the particular tracking



tolerance, operates with an accuracy that cannot be matched by single units geared together or by available conformity tolerance methods.

Specifying tracking eliminates errors due to an intermediate angle scale, angle differences between sections, gearing defects, voltage divider or test equipment errors, and end resistance. Repeatable error patterns are nullified by the self-correcting effect of the voltage difference signal. This voltage comparison technique eliminates dependence on terminal conformity. In nonlinear functions, this provides much greater checking accuracy throughout the range of the function. In single turn potentiometers, it is feasible to select sections (cups) by matching their curve, reducing differences, and thereby achieving much closer tolerances. Precision tracking units are subjected to functional testing which permits the system designer to specify tolerances closer to the system requirements. Each of these methods does have an effect on the unit price, and this should be taken into consideration when determining the necessity of a tracking potentiometer.

## CLOSED LOOP FUNCTIONS

A closed loop (electrical) function is a function that is active over  $360^\circ$  of rotation. Some of the most significant closed loop functions have already been reviewed in the previous discussions on nonlinear functions. The sine and cosine functions are two of the most common mathematically repetitive functions. There are many other applications, however, that utilize the concept of a closed loop function. One of the most popular type is a synchro-resolver. This is a  $360^\circ$  electrical function with three equally spaced taps, that is, at each  $120^\circ$  of electrical rotation. A function such as this with multiple taps is much more difficult to evaluate electrically than a simple series resistance. Since a closed loop function is much more accurately described by a series-parallel network, the potentiometer user must realize the importance of completely specifying the total resistance required. Any closed loop function must have the total resistance specified as the value of total resistance over a specific electrical rotation. In addition, it must be known whether the resistance is measured with the electrical loop closed or open.

## MECHANICAL PARAMETERS

In this modern age of electronics, it is easy for the potentiometer user to delay mechanical considerations until the final system design phase. In recent years, the importance placed on end product package size continues to remind engineers and designers of the relatively great importance of mechanical parameters. The potentiometer is

an electro-mechanical device and obviously has mechanical limitations in addition to the electrical ones previously discussed. Chapter 8 includes further details on mounting and packaging not included here.

A presentation of mechanical parameters requires a discussion of *mounting* methods including the effects of starting and running *torque*, *overtravels*, *backlash*, shaft, lateral, and pilot diameter *runouts*, end and radial *play*, *stop strength*, and mechanical *phasing*.

**Mounting.** There are two basic mounting styles of precision potentiometers—bushing and servo mount. Each is characterized by its particular application.

**Bushing — Manual Adjust.** Applications, such as those discussed in Chapter 5, all use a manually set bushing mounting style convenient for hand adjustment. The shaft is generally available with plain, slotted, or flatted end. Some bushings incorporate a self-locking feature. Many bushing mount styles have an anti-rotation pin extending from the mounting surface. Suitable drilling or punching of the mounting panel allows the engagement of the anti-rotation pin such that the housing is firmly restricted from rotating.

**Servo-Motor Driven.** Many precision potentiometers utilize the servo mount or screw mount style for motor driven applications. Either of these mounting styles can be recognized by the flanged, flat mounting face. The operating shaft extends through the mounting face. Fig. 6-14 shows typical examples of servo mount and screw mount potentiometers. The machining tolerances on the pilot diameter are held extremely close. These tolerances, generally less than  $\pm .001$  inch, are required to insure proper fit and concentricity with adjacent components such as servo drive motors. Additional measures to insure concentricity include close machining of the shaft diameter, the servo mounting flange diameter, and the mounting flange thickness.

Another significant feature in the design of motor or gear driven potentiometers is the use of ball bearings in the front and rear of the device. The ball bearings insure a longer life, better concentricity and closer mechanical interface match with adjoining components. Since the majority of precision potentiometer applications use servo mount units, the mechanical parameters discussed in the following sections are related directly to the servo mount style.

**Torque.** In many applications, the torque of a precision potentiometer is a critical design consideration. There are two types of torque to consider.

1. *Starting torque* is the maximum moment (of inertia) in the clockwise or counter-



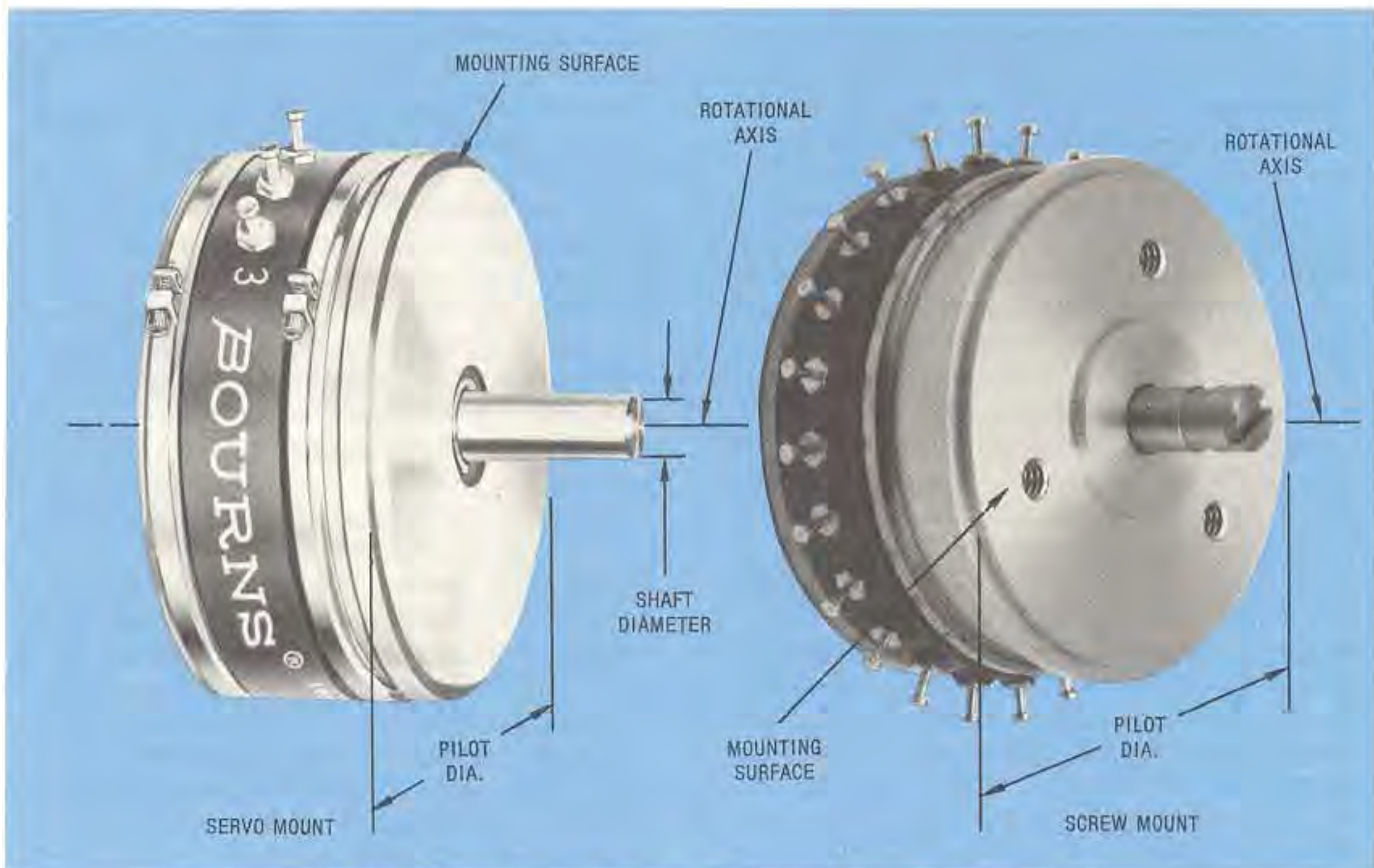

Fig. 6-14 Servo mount and screw mount potentiometers

clockwise direction required to initiate shaft rotation regardless of wiper position on the element.

2. *Running torque* is the maximum moment (angular force) in the clockwise or counter-clockwise direction required to sustain uniform shaft rotation at a specified speed throughout the total mechanical travel.

Generally, starting torque for a precision unit is less than 2 ounce-inches. The running torque is usually 75% to 80% of the starting torque. The actual torque values are dependent on the diameter of the potentiometer and the total number of sections on a common shaft. Fig. 6-15 is a table of starting and running torques. The values shown are for single section units only.

**Overtravels.** In Chapter 2, the various travel ranges for potentiometers are presented in detail. These ranges are total mechanical travel, actual electrical travel, and the theoretical electrical travel. In precision potentiometer applications, the intimate relationship between electrical and mechanical parameters necessitates the use of overtravel terminology to describe or control the relationship of the various travel ranges. There are two overtravels used throughout the industry—mechanical overtravel and electrical overtravel.

*Mechanical overtravel* refers to the range of wiper travel between the end point (or theoretical end point) and its adjacent end stop or limit of total mechanical travel. It is common to ex-

DIAMETER (Inches)	STYLE (Mounting and Rotation)	STARTING (oz.-in.)	RUNNING (oz.-in.)
7/8	BUSHING/SINGLE-TURN	.15	.15
1 1/16	BUSHING/SINGLE-TURN	.20	.20
2	BUSHING/SINGLE-TURN	1.50	1.00
7/8	SERVO/SINGLE-TURN	.10	.10
1 1/16	SERVO/SINGLE-TURN	.10	.10
2	SERVO/SINGLE-TURN	1.00	.60
1/2	BUSHING/MULTI-TURN	.60	.60
7/8	BUSHING/MULTI-TURN	.50	.50
1 3/16	BUSHING/MULTI-TURN	2.00	2.00
1/2	SERVO/MULTI-TURN	.50	.30
7/8	SERVO/MULTI-TURN	.40	.30
1 3/16	SERVO/MULTI-TURN	1.20	.80

Fig. 6-15 Maximum torque values for single section units only

press mechanical overtravel in degrees of shaft rotation.

*Electrical overtravel* refers to the range of wiper travel between the end of the actual electrical travel (or theoretical electrical travel) and the adjacent end stop or the point at which electrical continuity between wiper and element ceases.

*Backlash* refers to the maximum allowable difference in actuating shaft position that occurs when the wiper is positioned twice to produce



the same output ratio but from opposite directions. When a backlash test is made, the actual wiper position on the element is obviously identical for each measurement. Any difference in mechanical position of the shaft (backlash) is due to mechanical tolerances of the total actuating system.

**Mechanical Runouts.** To insure proper fit and function with adjacent mechanical components, the precision potentiometer is designed to conform to specific mechanical runouts with respect to the actuating shaft. Five common mechanical runout parameters are described in the following paragraphs. Refer to Fig. 6-14.

*Shaft runout* refers to the eccentricity of the shaft diameter with respect to the rotational axis of the shaft. It is measured at a specified distance from the end of the shaft. The body is held fixed and the shaft is rotated with a specified load applied radially to the shaft. The eccentricity is expressed in inches of total indicator reading (TIR). Control of shaft runout insures that the potentiometer will run true and not cause uneven wear in the mating component or the potentiometer itself.

*Lateral runout* refers to the perpendicularity of the mounting surface with respect to the rotational axis of the shaft. It is measured on the mounting surface at a specified distance from the outside edge of the mounting surface. The shaft is held fixed and the body is rotated with a specific load applied radially and axially to the body. The lateral runout is expressed in inches of total indicator reading.

*Pilot diameter runout* refers to the eccentricity of the pilot diameter with respect to the rotational axis of the shaft. It is measured on the pilot diameter. The shaft is held fixed and the body is rotated with a specified load applied radially to the body. The eccentricity is expressed in inches of total indicator reading. For many servo applications the pilot diameter is extremely critical. Its relationship to adjacent surfaces is also critical. Therefore, the allowable pilot diameter runout is controlled to insure minimum build up of tolerances.

*Shaft radial play* refers to the total radial excursion of the shaft. It is measured at a specified distance from the front surface of the unit. A specified radial load is applied alternately in opposite directions at the specified point. Shaft radial play is specified in inches.

*Shaft end play* refers to the total axial excursion of the shaft. It is measured at the end of the shaft with a specified axial load applied alternately in opposite directions. Shaft end play is expressed in inches.

Shaft radial play, end play, and the runouts are controlled by the manufacturer to provide opti-

imum mechanical life and the highest accuracy possible for interfacing with adjacent mechanical components. The potentiometer user should recognize that any mechanical misalignment of adjacent components with respect to the operating shaft can result in a load on the shaft that will degrade the potentiometer's maximum rotational life.

**Stop Strength.** The stop strength specification means *static* stop strength. It is the maximum static load that can be applied to the shaft at each mechanical stop. The force is applied for a specified period of time and no permanent change of stop position, greater than specified, is allowed. Single turn precision potentiometers usually do not have stops. They are continuous rotation devices with a nonconductive bridge between ends of the resistance element. The contact sweeps across the bridge and returns to zero without a change in the direction of rotation.

Some single turn and all multiturn precision potentiometers have mechanical stops at each end of rotation. The stop strength of the unit is dependent on its physical size. In general, the larger the diameter, the higher the stop strength. Most motor and gear driven potentiometers have higher rotational forces applied to the operating shaft than the stop strength rating. Unless the manufacturer is made aware of special requirements, the stop strength of the potentiometer is usually *not* sufficient to function as a stop for the whole system.

## PHASING

Phasing is a parameter used to describe the relationship of one potentiometer output function to another. Although phasing can be used to describe the relationship between two separate devices, it is generally used to describe the relationship of one section to another in a multiple section precision device. In most applications, it is extremely difficult to discuss an electrical phasing requirement without discussing mechanical effects. The phase relationship in most nonlinear output functions, built in multisection assemblies, is established by the physical location of the wiper in one section with respect to the wiper position in another section. The common location is referred to as the *phasing point*. Phasing is often done internally so the potentiometer user may not be aware of a physical difference from outside appearance.

Another method used to establish the phasing of multisection devices is rotating the body of one section with respect to another. This is possible through the use of clamp ring sections as shown in Fig. 6-16. The phase relationship of multiple sections is normally specified by the user when the potentiometer is designed. The ability



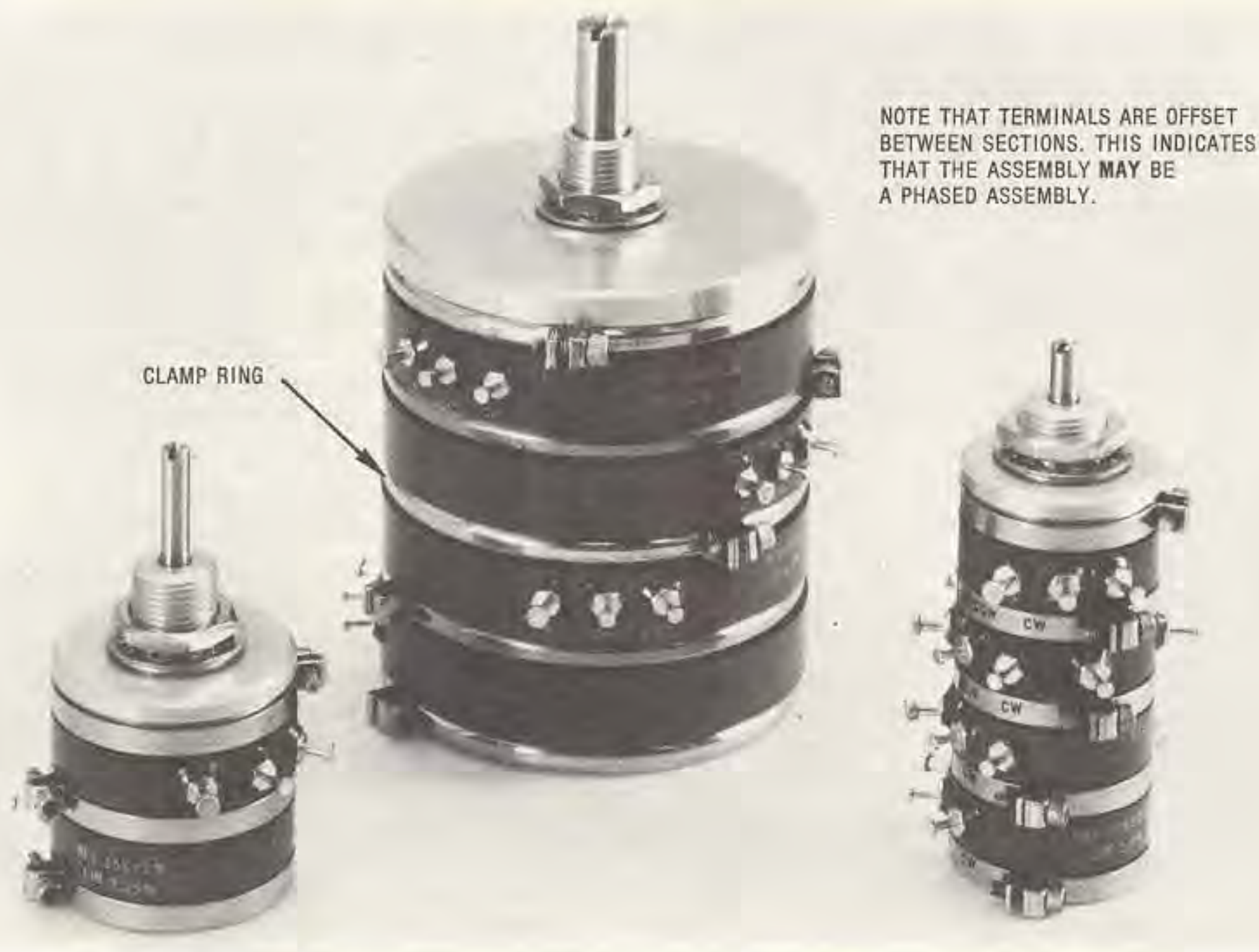

Fig. 6-16 Clamp ring style, phased potentiometer

to change phase relationships of multiple sections and to vary electrical and mechanical angles has significant benefit to the potentiometer user. However, once the device has been built, the clamp ring set screws are usually secured in some fashion (ie., with an adhesive). This sealing may make changes impossible without violation of manufacturer's warranty.

## NONWIREWOUND PRECISION POTENTIOMETERS

Nonwirewound potentiometers have a number of characteristics which differ from wirewound devices and may require special consideration for successful application.

Over the past several years, precision nonwirewound potentiometers have gradually replaced the wirewound device in many commercial, military, and aerospace applications. In most instances, the changeover was accomplished successfully. In other instances, problems arose that were ultimately solved. In the process, both users and manufacturers gained a better understanding of the performance characteristics of these devices.

Nonwirewound potentiometers, such as conductive plastic and cermet, differ in their nature from wirewounds. Conductive plastic

provides two to four orders of magnitude improvement in rotational life. Many other equally important characteristics pertinent to potentiometer performance in the circuit, the system, and the environment are also different.

Basic nonwirewound element types and their construction are covered in detail in Chapter 7. The following sections discuss some important considerations for nonwirewound *precision* potentiometers such as contact resistance, output loading, effective electrical travel, and multiple taps. Included are some of the more subtle performance tradeoffs required for the optimum design. These subjects are treated in detail elsewhere in this book, and the index should be consulted for further study.

**Contact Resistance.** Contact resistance appears as a resistance between the wiper (contact) and the resistance element and may be shown schematically as in Fig. 6-17. Contact resistance may be thought of as the sum of fixed and variable components. The variable part is generally a fraction of the fixed component. The value of contact resistance is a function of the geometry of the resistive element, contact configuration, and the area of contact between the wiper and the resistance element. For a given geometry of element and contact, the contact resistance is proportional to the resistivity of the element ma-



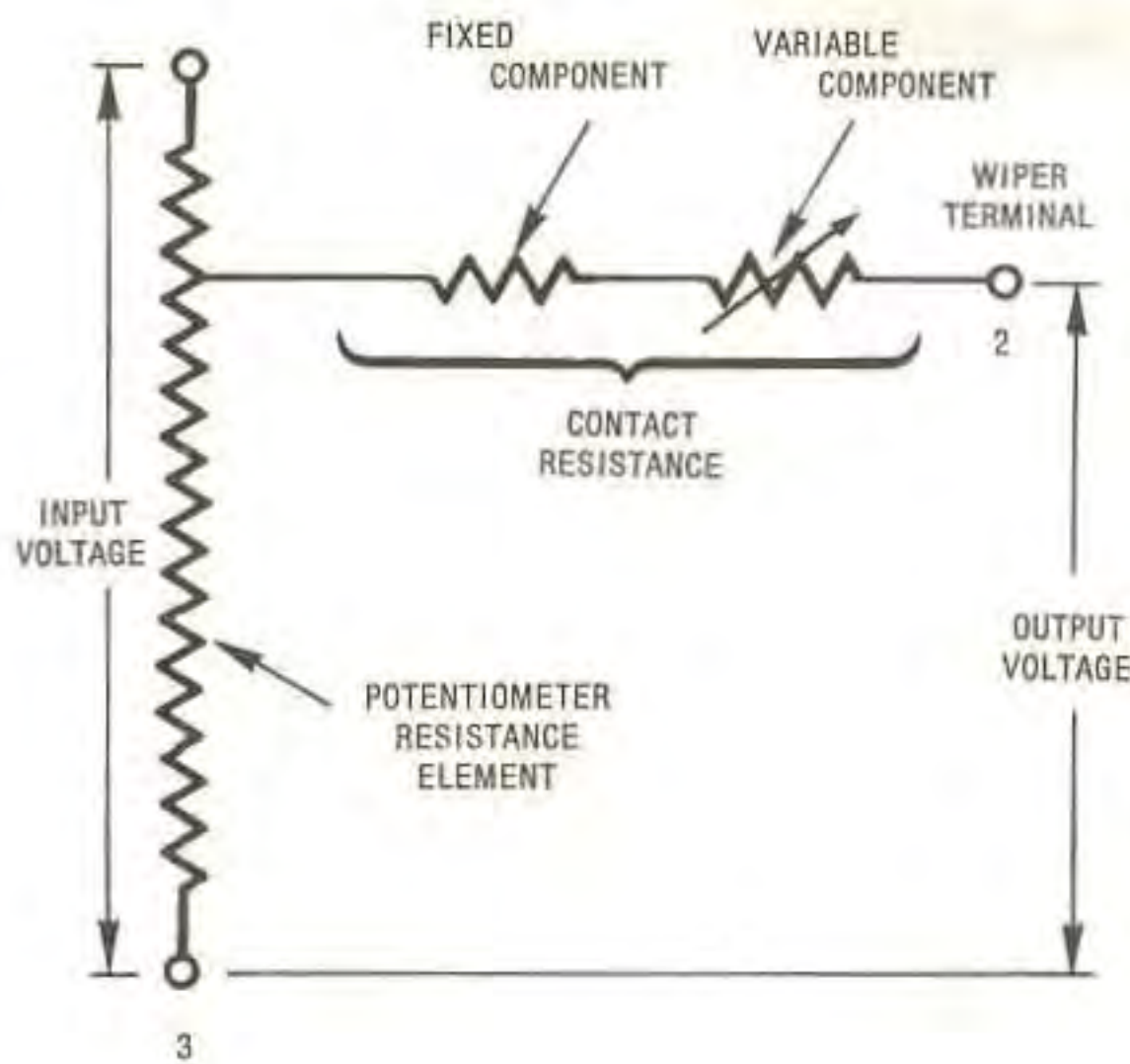

**Fig. 6-17** Contact resistance appears as a resistance between the wiper (contact) and the resistance element

terial and may be expressed as a percentage of the total resistance. Contact resistance can be lower than 1% and can range upwards to 10% for certain elements.

In cases where the application requires the lowest possible value of contact resistance, use the largest possible potentiometer diameter and the longest electrical angle consistent with the available space. These measures will, in combination with the manufacturer's choice of resistive element geometry and contact design, act to minimize contact resistance. During the rotational life of the potentiometer contact resistance changes. The fixed component generally becoming smaller and the variable component larger. The significance of contact resistance is dependent on the circuit into which the potentiometer output operates. In potentiometers requiring tight conformity, the first question to consider is whether it is the deviation from the theoretical output that is important (such as a function generator) or whether the output fidelity can be more appropriately stated in terms of tracking accuracy of output smoothness between separate potentiometers (such as those used in remote position and follow servo systems).

**Output Loading.** In many applications the nonwirewound resistance element linearity must

be compensated with respect to output load. The output load ratio is defined as the nominal output load resistance divided by the element nominal total resistance ( $R_L/R_T$ ). The load ratio should always be greater than ten to one. There are two important reasons for this limitation. If the load ratio becomes excessively low, the wiper current may become sufficient to seriously degrade the useful life of the resistance element. The other reason for the load ratio limitation is due to the manufacturing processes involved with nonwirewound resistance elements. It is difficult to achieve a total resistance tolerance less than approximately  $\pm 5\%$ . This situation creates no problem if the load ratio is 100:1 and the linearity tolerance is  $\pm 1.0\%$ . However, if the load ratio is 5:1 and the linearity tolerance is  $\pm .05\%$  circuit analysis reveals the total resistance  $R_T$  and the load resistance  $R_L$  must be controlled to less than  $\pm 1\%$ . Fig. 6-18 shows the relationship between the load ratio, the tolerances of total resistance and load resistance, and associated linearity error.

SUM OF TOLERANCE ON TOTAL RESISTANCE AND LOAD RESISTANCE	$\frac{R_L}{R_T}$	5:1	10:1	20:1	50:1	100:1
$\pm 1.0\%$		0.028	0.015	0.0075	0.003	0.0015
$\pm 2.0\%$		0.055	0.030	0.015	0.006	0.003
$\pm 3.0\%$		0.082	0.045	0.023	0.009	0.0045
$\pm 5.0\%$		0.140	0.075	0.038	0.015	0.0075
$\pm 10.0\%$		0.280	0.150	0.075	0.030	0.015

TABLE 1

**Fig. 6-18** Linearity error (%) for various load ratios

**Electrical Travel.** The electrical travel of nonwirewound potentiometers is built in during manufacture and cannot be modified later. The degree of accuracy achieved is a function of the manufacturing process and the size and the type of element. Nonwirewound resistance elements also have the unique characteristics that the output voltage does not change linearly in the immediate vicinity of the end terminations. For this reason the actual electrical travel as defined in wirewound technology has no meaning when applied to nonwirewound elements. A more meaningful specification is defined by the output voltage versus shaft position function and the required linearity or conformity. When these are properly defined a *theoretical electrical travel* and its associated angular tolerance can be specified.



**Multiple Taps.** When multiple taps are required on a nonwirewound potentiometer, special precautions must be taken. There are two types of taps available. The *current* tap consists of a conductive strip crossing the entire width of the resistance element perpendicular to the wiper path as shown in Fig. 6-19. The current tap acts as a miniature resistance short and disturbs the linearity of the element. The magnitude of this disturbance depends upon the relative size of the element and the manufacturer's process. The current tap can safely carry the same amount of current as the end terminations. The *voltage* or *zero width* tap consists of a conductor which barely touches the edge of the resistance track as shown in Fig. 6-20. A voltage tap has negligible effect on the linearity. Obviously the current carrying capability of this type of tap is limited.

When deciding which type of additional tap to specify for a given application it is unnecessary to consider the current carrying capabilities. It is more realistic to consider how the tap is used in the circuit. If a single voltage is applied to the tap a current tap is required. However, if an equal positive and negative voltage is applied between a center tap and the end terminals, a voltage tap may be used in the center. A voltage tap may be used when the tap is sensing voltage only and the measurement circuit has a high impedance. The method of specifying locations for the two types of taps differs. A voltage tap should always be located at some specified voltage with a tolerance. The angular location of a voltage tap is immeasurable due to the two-dimensional characteristic of the nonwirewound resistance element. The location of a current tap may be specified in terms of voltage or angular position. When angular position is specified, care must be exercised so that a measurement technique is defined and a realistic tolerance is assigned.

**Temperature Coefficient of Resistance and Moisture Sensitivity.** The total resistance of conductive plastic and cermet is known to be more sensitive to moisture and temperature than are wirewounds. The change in resistance occurring from exposure within the rated temperature range or from the extremes of room ambient humidity has little effect on other intrinsic characteristics. However, the changes in total resistance due to the temperature coefficient of resistance (TC) are sufficient to preclude the use of any external resistors as balancing resistors or as a voltage divider. To verify this, consider a typical 6% change in TR (for conductive plastic) from  $-65^{\circ}\text{C}$  to  $+100^{\circ}\text{C}$  (363 PPM/ $^{\circ}\text{C}$ ). To use a conductive plastic potentiometer as part of a divider network, the network should be built into the potentiometer resistance element. Series resistors made in this fashion will track the

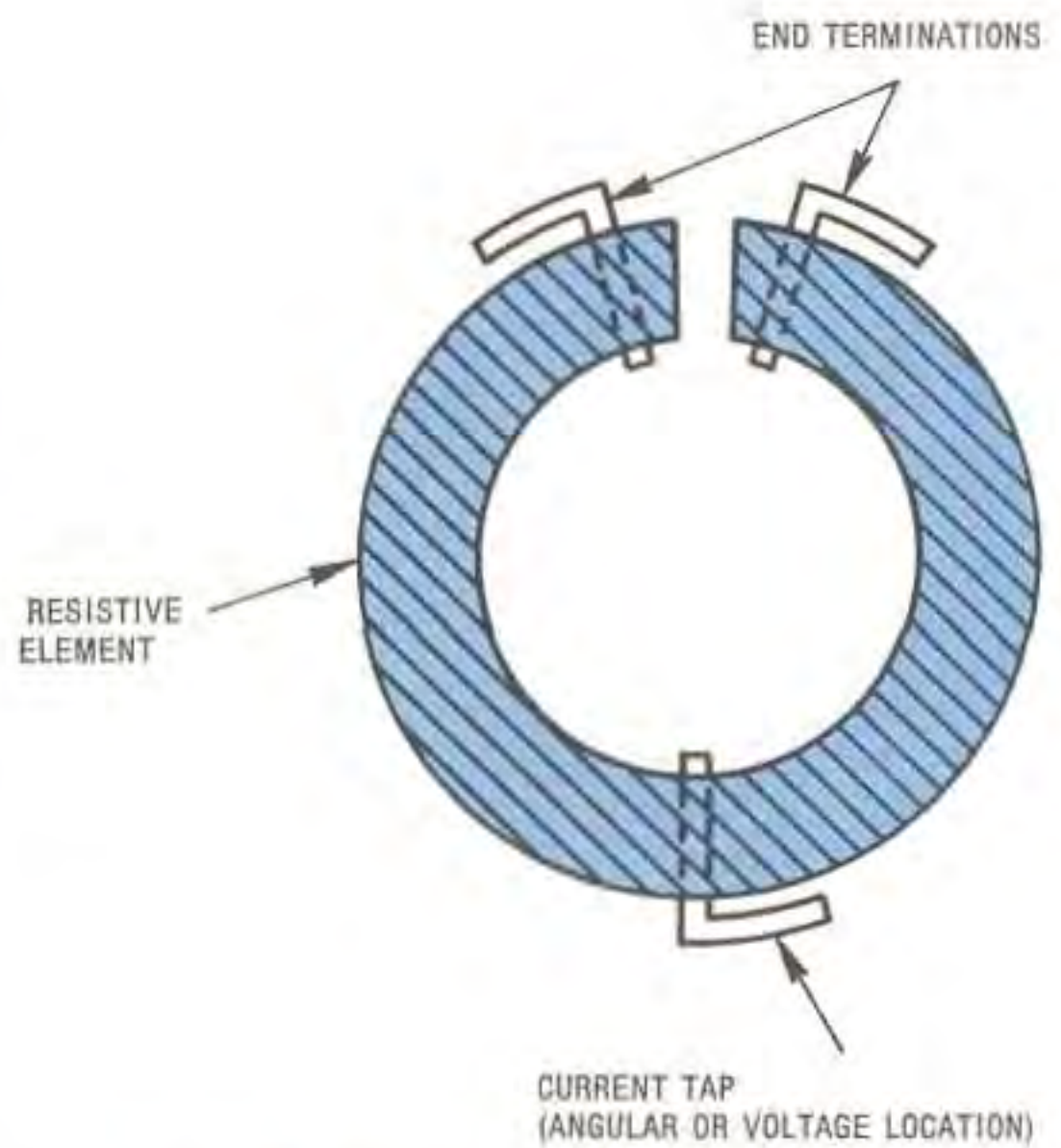

**Fig. 6-19** Current tap for nonwirewound element

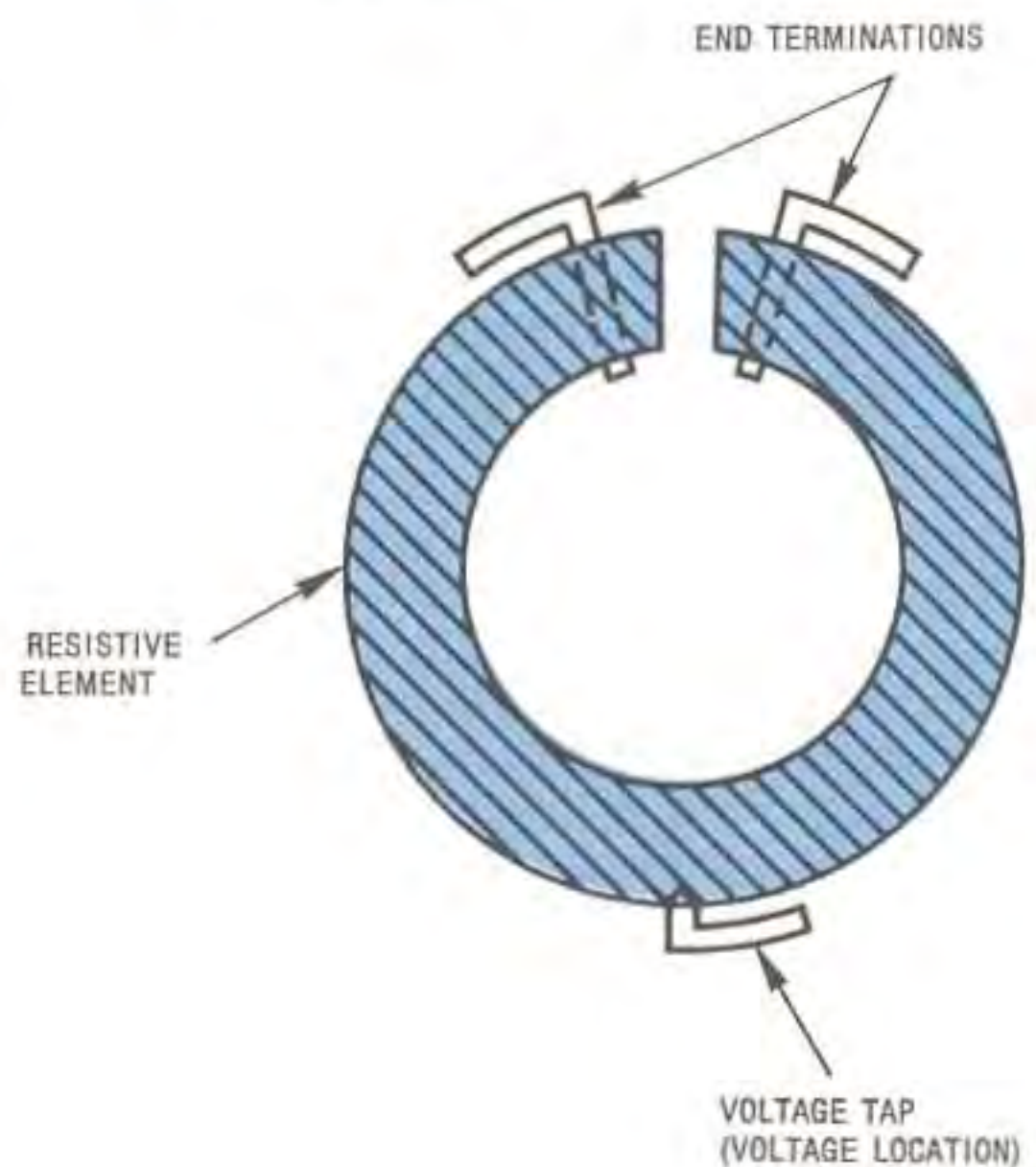

**Fig. 6-20** Voltage tap for nonwirewound element

potentiometer section within the limits of normal linearity and conformity tolerances because the potentiometer and resistors are made of the same material and generally vary proportionately. The cost for these resistors (built into the potenti-



ometer) is generally less than the cost of the resistors purchased separately combined with the labor to connect them externally. For optimum performance of potentiometers with built-in resistors, specify the actual voltage at which the potentiometer will operate. This will permit the matching of the series resistors to the potentiometer element at the actual working voltage.

In recent years, state of the art advances have reduced the change in total resistance resulting from exposure to humidity to approximately 5%. In most applications where a repeatable accurate TC is required, it is necessary to stabilize the moisture content of the resistance element with a few hours exposure at temperatures around 50 to 80°C.

## LINEAR DISPLACEMENT TRANSDUCER

One of the basic precision potentiometer applications is that of converting mechanical linear motion to rotary motion and utilizing the resultant output. The linear displacement transducer assembly shown in Fig. 6-21 is a simple but very effective method. It uses a multiturn or single-turn servo mounted precision potentiometer, and can measure relatively great displacements compared to its size. This particular transducer uses

a spring return mechanism on the cable. The spring return is contained within the larger cylindrical body that accepts the operating shaft. The required effective electrical angle is based on the length of the cable required by the transducer application. This particular combination eliminates many of the mechanical interface problems inherent in gear and motor drive assemblies.

One application for this transducer assembly is in test aircraft. The assembly is mounted on the engine or in the cockpit or anywhere that a measure of linear motion (i.e., the throttle or a control surface) is required. The linear displacement of the mechanical linkage is transmitted to the potentiometer operating shaft with a 1 to 1 ratio through the cable. By applying a fixed voltage across the end terminal and the wiper, the mechanical motion is converted to an electrical signal which can be transmitted directly to a recording device or sent to a ground tracking station by external telemetry equipment. This is only one of many linear motion-to-electrical-signal transducer applications.

## LOW TORQUE POTENTIOMETERS

Another application of precision potentiometers is one required by precision measuring instruments such as meteorological (weather) in-

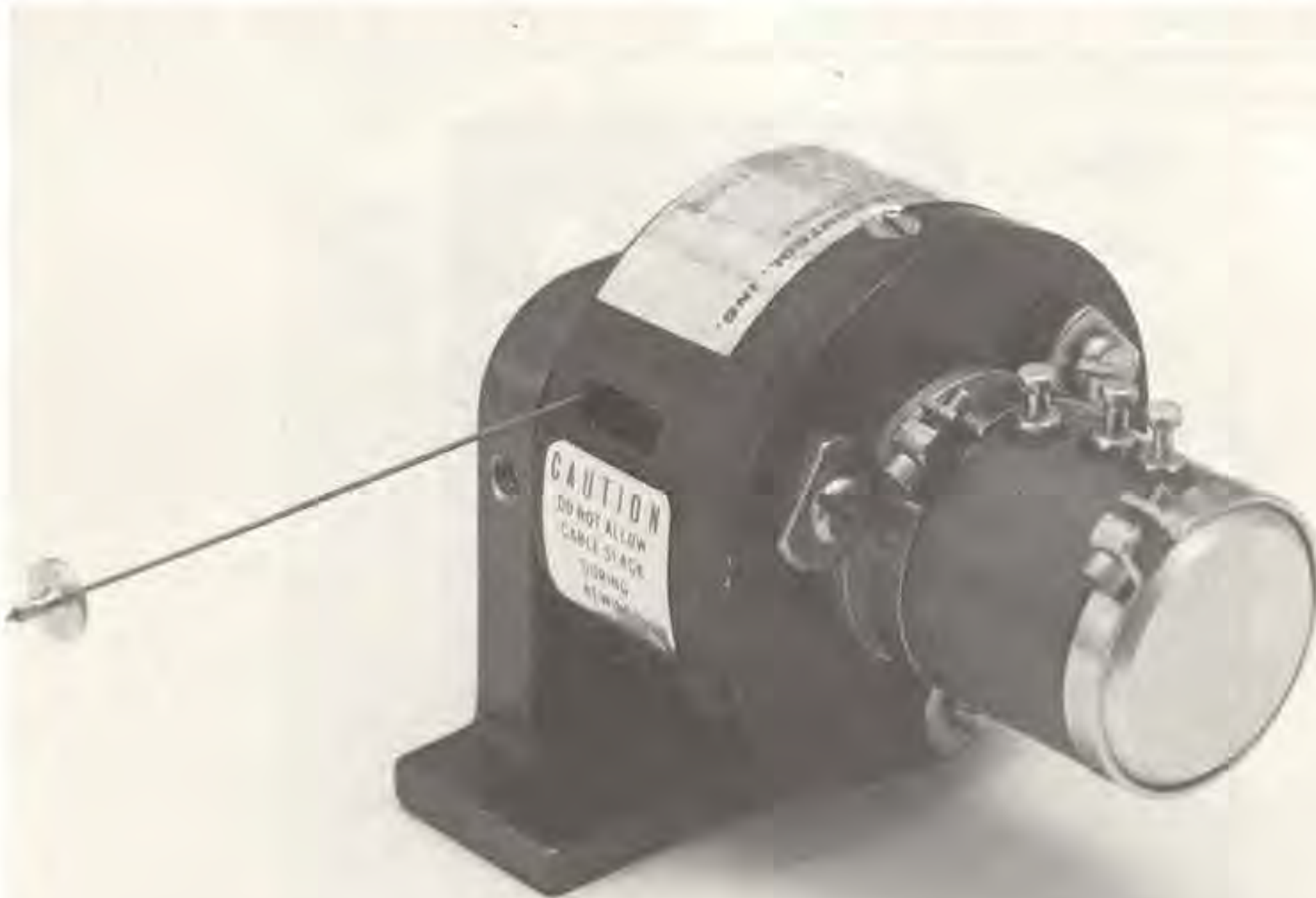

**Fig. 6-21** Cable type linear displacement transducer (Space-Age Control, Inc.)



strumentation. A low torque potentiometer application generally requires torques less than 0.1 oz.-in., even with multiple sections. A servo mount ball bearing potentiometer of 1 inch diameter or less with an 1/8 inch diameter shaft is most suitable. The resistance element can be wirewound or conductive plastic. In the wirewound device, the key to low torque is the bridge between the ends of the element. Applications such as electronic weather vanes and anemometers require 360° of continuous mechanical rotation. Since most potentiometers have an effective electrical angle of 350°, the electrical angle must either be extended to as close to 360° as possible or the 10 degree travel area between the ends of the element must be designed with an extremely smooth transition surface.

In a wirewound device, it is best to keep the total resistance above 10K ohms for low torque requirements. This will force the diameter of the resistance wire to be small enough and the pitch for the winding on the resistance element close enough to provide a relatively smooth surface for the wiper to traverse. Generally, the torque will be highest over the bridged area between the ends of the resistance element. For example, if the application allows torques in the range of .05 oz.-in. with the wiper on the element, the torque over the bridge will generally be .07 to .10

oz.-in. Some variation of these values is possible by modifying the pressure of the wiper against the element. If the wiper pressure is decreased, the amplitude of the electrical noise is increased. There are ways of counteracting the increase of noise that involve the use of precious metal resistance wire which has an obvious effect on the cost of the unit as well as performance parameters.

This type of wirewound precision potentiometer usually requires connecting an external terminal to the resistance element with a small single wire tap. The circuit designer should design in a current-limiting device in the circuit with the potentiometer to control any surge current when the wiper is approaching the inactive bridge portion of the element or when the wiper is returning to the active area of the element.

### COARSE/FINE DUAL CONTROL

One of the methods for multiple function front panel control is the dual concentric shaft potentiometer. This method is gaining popularity with precision instrument manufacturers. Fig. 6-22 shows the front panel of a spectrum analyzer. The inner and outer knobs in the frequency section of the front panel form the

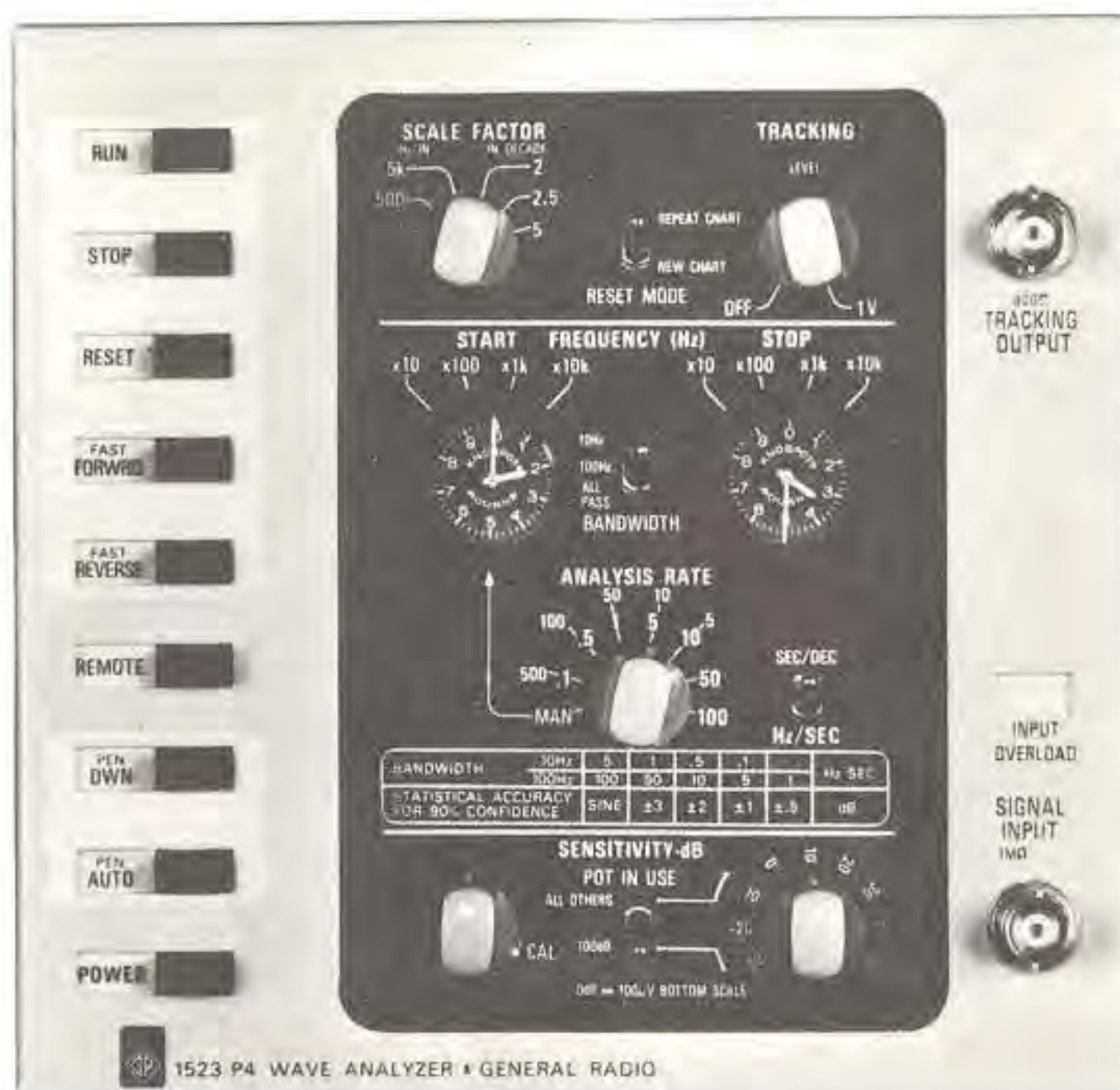

Fig. 6-22 Spectrum analyzer with coarse/fine dual concentric shaft control for frequency tuning (General Radio Co.)



frequency tuning control. This control consists of two parts, coarse tuning (larger knob) and fine tuning (smaller knob). The tuning control adjusts the center frequency or start frequency of the spectrum displayed.

The potentiometer is a multiturn, nonwire-wound device with two sections. Each section is operated independently by means of dual concentric shafts. Extremely fine resolution and precise tuning ability were the deciding factors in selecting a multiturn potentiometer with a conductive plastic resistive element in each section. The output of both the coarse and the fine tuning adjustments are fed into a summing operational amplifier. The voltages are then fed through a voltage-to-current transfer circuit. The resultant current is applied to the field of a YIG oscillator where the frequency is determined.

## POSITION INDICATION/TRANSMISSION

Fig. 6-23 shows a basic position transmission system arrangement using potentiometers for both transmitter and receiver (indicator). This simplified circuit shows how potentiometers can be used to transmit a relative mechanical position from one point to another.

The original mechanical motion may be the output of a driven system such as a servomechanism. It could also be an operator induced motion such as a front panel control of an instrument. The instrument might use a turns-counting dial to permit precise operator setting of certain

critical adjustments. The reading on the turns-counting dial corresponds directly to the magnitude of some variable such as voltage level, temperature, frequency, or a time interval.

As long as the relative position of the wipers in Fig. 6-23 is the same, no input voltage will be applied to the servo amplifier and the motor will not turn. When the position of the transmitter  $R_1$  is moved, an unbalance occurs and the differential input voltage to the amplifier produces an output drive signal to the motor. The motor turns in the proper direction to reduce the error (difference) signal to zero. The end result is the receiver potentiometer  $R_2$  duplicates the position of the transmitter.

The precision with which the position is transmitted is dependent upon the accuracy of the two potentiometers and the gain of the servo amplifier system. If the gain is made too high, the receiver potentiometer will oscillate (hunt) as it attempts to find a position where the error voltage is zero. Resolution in the receiver potentiometer is very important as it determines the amount of gain which will be permitted without oscillation. If the resolution is too poor, then the error signal presented to the input of the amplifier may jump from a positive level to a negative level as the wiper moves from one turn to the next. Even if the oscillation — sometimes called *dither* — is not especially objectionable from an operations standpoint, it should not be permitted because of the resulting local wear on the element, the wiper, and the whole electromechanical system.

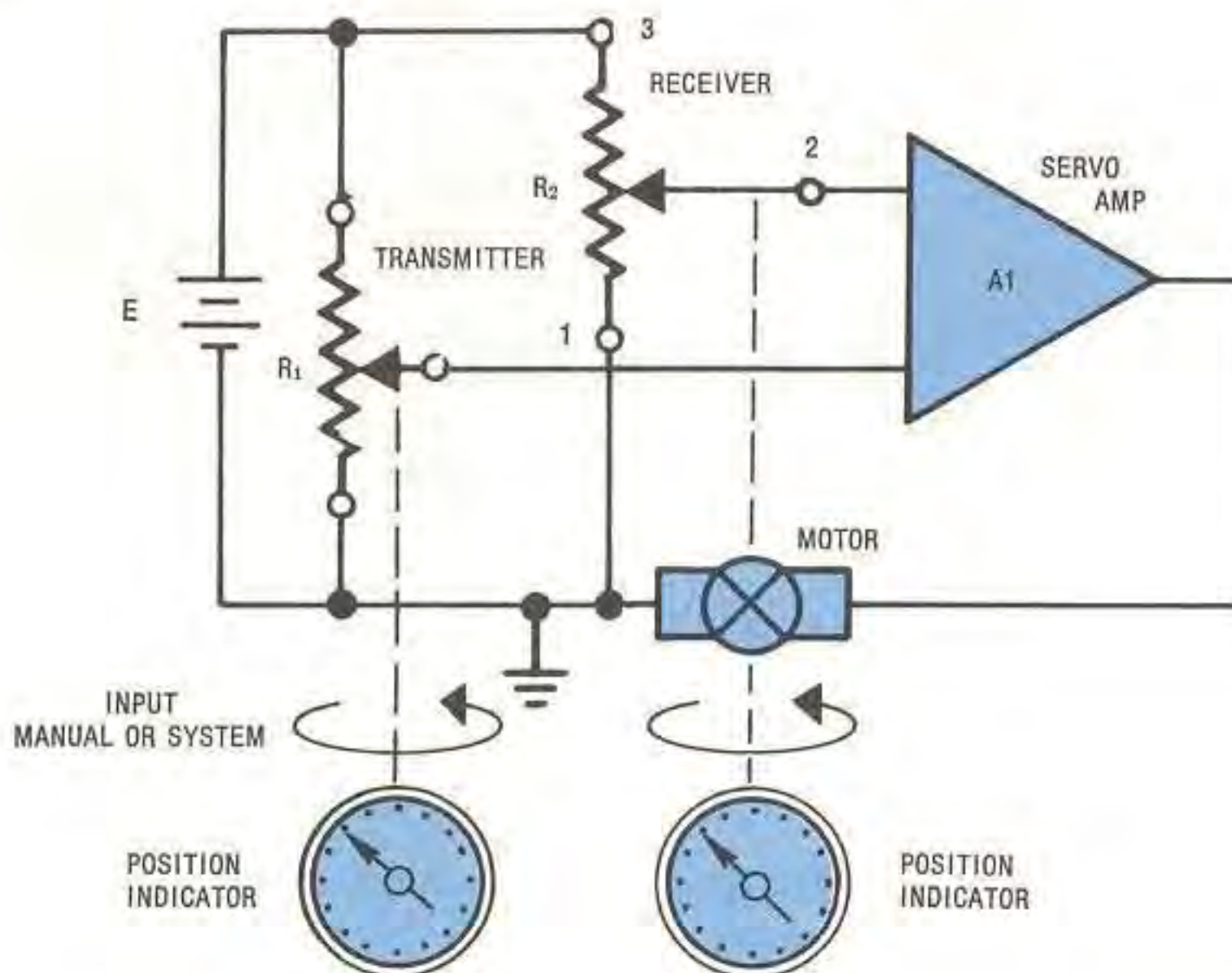

Fig. 6-23 A basic position transmission system using potentiometers for transmitter and receiver



## THE X-22A, V/STOL AIRCRAFT

The aircraft pictured in Fig. 6-24 uses dual tandem ducted propellers to provide an aircraft for flight research and evaluation of this unique configuration. More importantly it provides a highly versatile aircraft capable of general research on vertical/short takeoff and landing (V/STOL) handling qualities using a variable stability system.

The variable stability system allows the pilot to change the dynamic characteristics of the aircraft in flight and to simulate the flying qualities of future aircraft that are on the drawing boards. The aircraft is in reality a flying simulator, allowing the pilot to feel the aircraft motions in a natural sense unlike fix based ground simulators.

Because of the uniqueness of the aircraft (it's the only one of its kind) constant monitoring is provided by an airborne telemetry system which transmits data to a mobile monitoring station. The data is observed on strip chart recorders and analog meters. A minicomputer constantly monitors safety of flight items and immediately warns of any aircraft parameter that departs from its normal range.

In the computer over 170 amplifiers and special function modules are wired to a patch board along with 100 wirewound, digital readout potentiometers. This patch board is shown in Fig. 6-25. Some of the potentiometers (3-10) are remotely mounted in the cockpit. Pilot comments have been favorable regarding reading and setting these devices in a crowded cockpit.

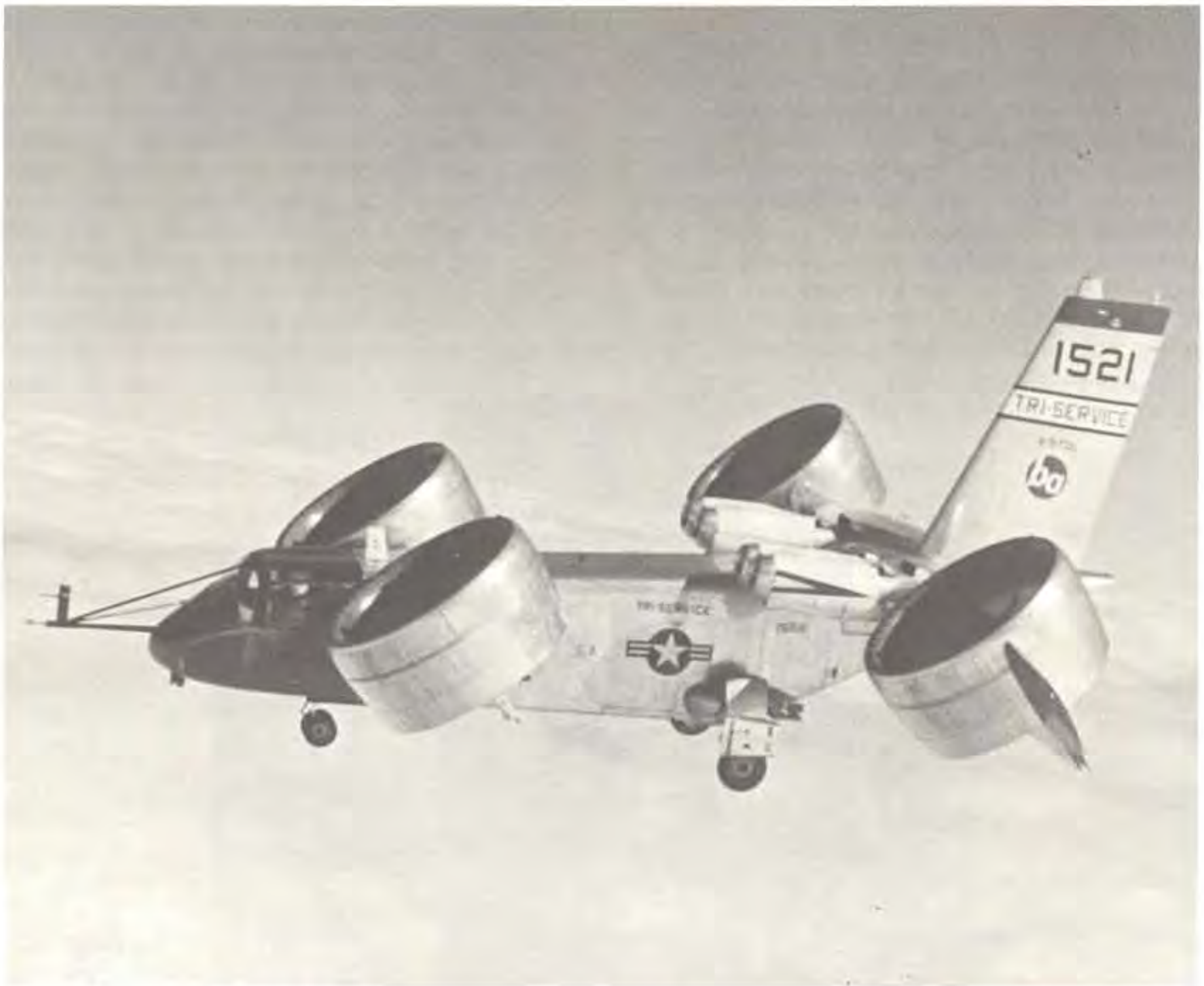

**Fig. 6-24** An experimental aircraft (Bell Aerosystems/U.S. Navy)



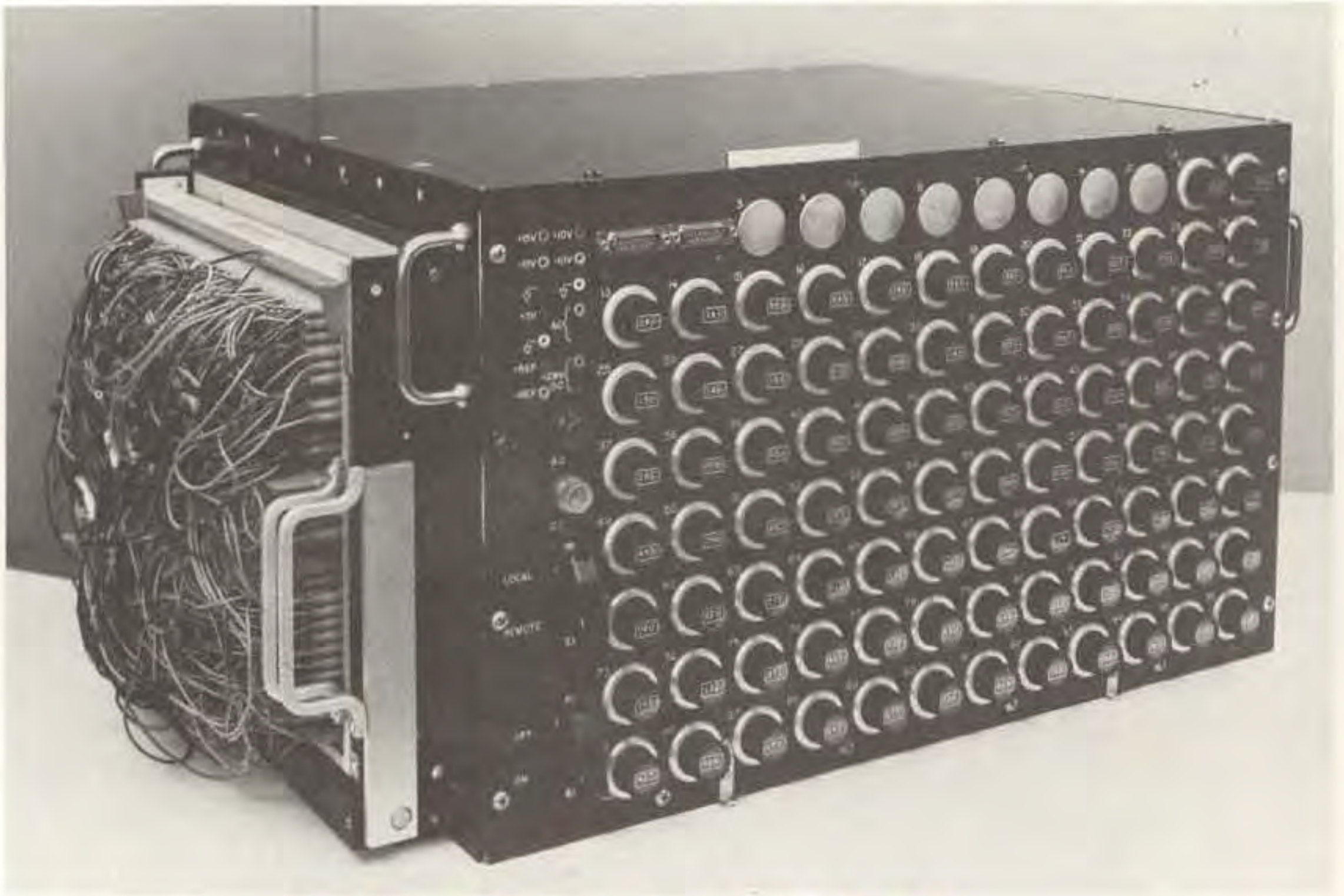

**Fig. 6-25** Patchboard used in aircraft of Fig. 6-24  
(Flight Research Dept. of Calspan Corp.)

## DENDROMETER

As a part of a project to investigate the relationship of tree growth to the factors of forest environment, scientists designed an electrical dendrometer band (a device that measures growth by measuring tree girth) utilizing a precision potentiometer.

As shown in Fig. 6-26 the potentiometer is mounted on a bracket at one end of a metal band that is passed around the circumference of the tree. A stainless steel wire, attached to the bracket via a spring, is wrapped several times around the potentiometer shaft and attached to the other end of the band. A simple reliable transducer is the result. Any growth in the tree diameter (girth) causes the band to pull the wire turning the shaft proportionately, thus, changing the resistance value of the potentiometer.

Two of the main advantages of the potentiometer dendrometer band are its relatively low cost and its ability to operate successfully in remote forested areas where reliable electrical power is difficult to obtain. These features enable tree growth measurements to be taken manually by simply reading the resistance of each poten-

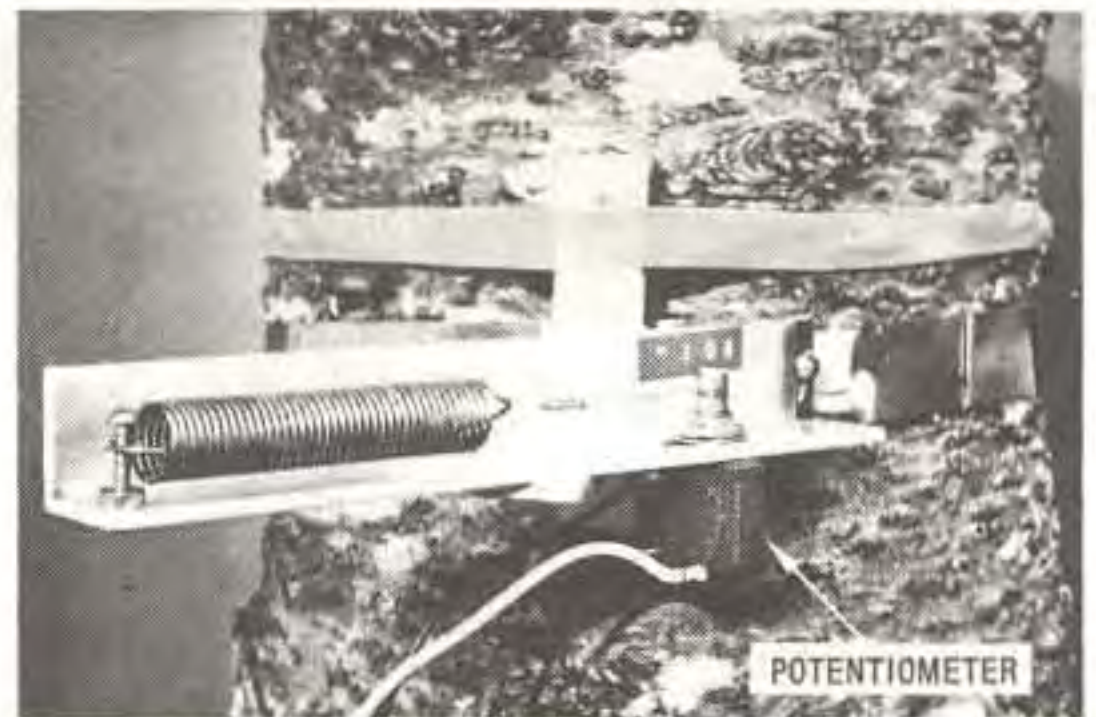

**Fig. 6-26** Dendrometer for monitoring tree growth

tiometer/dendrometer band with a portable digital ohmmeter at regular intervals. No direct power supply of any sort is required, and bands can be located in upper areas of a tree with leads running down the trunk for easy monitoring.



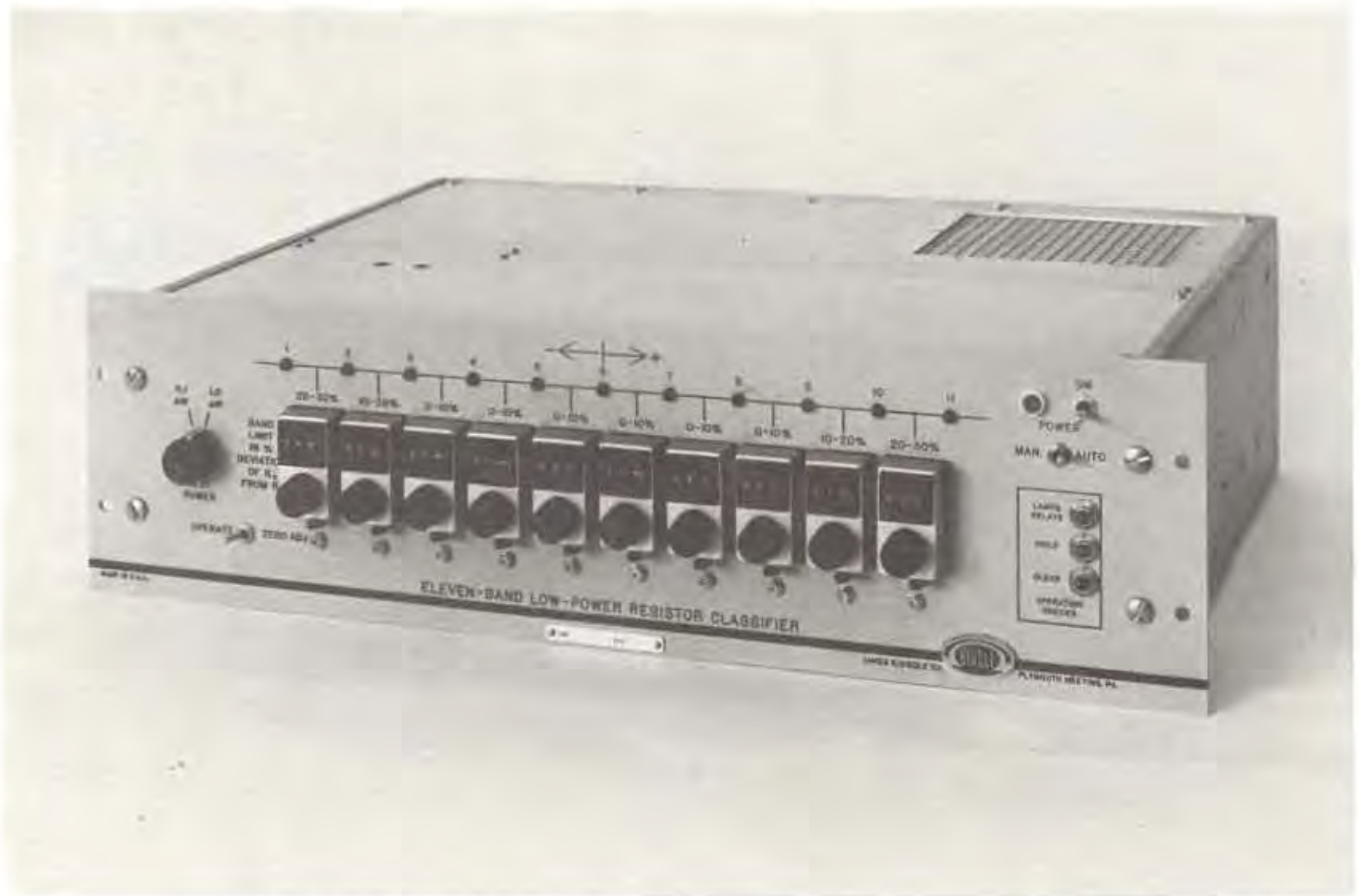

**Fig. 6-27** A bridge used for high speed sorting of resistors and thermistors. (James G. Biddle Co.)

## SORTING BRIDGE

The high speed sorting bridge in Fig. 6-27 is used with a suitable parts handler for accurately sorting resistors or thermistors into as many as ten different classifications. The unknown resistance is checked against ten individually set tolerance limit bands between  $\pm 0$  and  $\pm 30\%$ . In operation, the bridge selects the proper category and signals an automatic handler to feed the resistive component to the corresponding bin.

A power dissipation circuit senses the unknown resistance value and adjusts bridge voltage to maintain equal dissipation for various resistance values.

A unique dual-null multiband sorter permits comparison of the unknown resistance to several reference levels simultaneously rather than sequentially. This speeds the sorting process and eliminates error inducing switching.

The ten dials shown in the photo each operate a ten-turn precision wirewound potentiometer for tolerance setting control. The range of each dial is 10% and the potentiometer can be set anywhere in this band within 0.01%. Here is an example of precision devices being used in a control function as discussed in Chapter five.

## MULTI-CHANNEL MAGNETIC TAPE RECORDER

A variety of adjustment, control and critical precision potentiometers are used in the multi-channel magnetic tape recorder pictured in Fig. 6-28.

Precision potentiometers are in the electronically controlled tape tensioning system which is part of the electronic control for the spooling motors. This system measures the actual tape tension on both the right and left sides. The tape tension sensor acts as tape storage and mechanical damping elements. The offset capstans shown in Fig. 6-29 cause the tension sensor to rotate in proportion to tape tension. Position of the sensor is converted into proportional voltage (actual value) by the directly driven high precision single turn potentiometer. The potentiometer is connected to the differential amplifier of the spooling motor control amplifier. The control voltage for the normal fast running mode or the manually controlled winding influence the reference input (set value) of the differential amplifier. With this system, the tape tension is electronically controlled even during the fast forward and rewind modes.



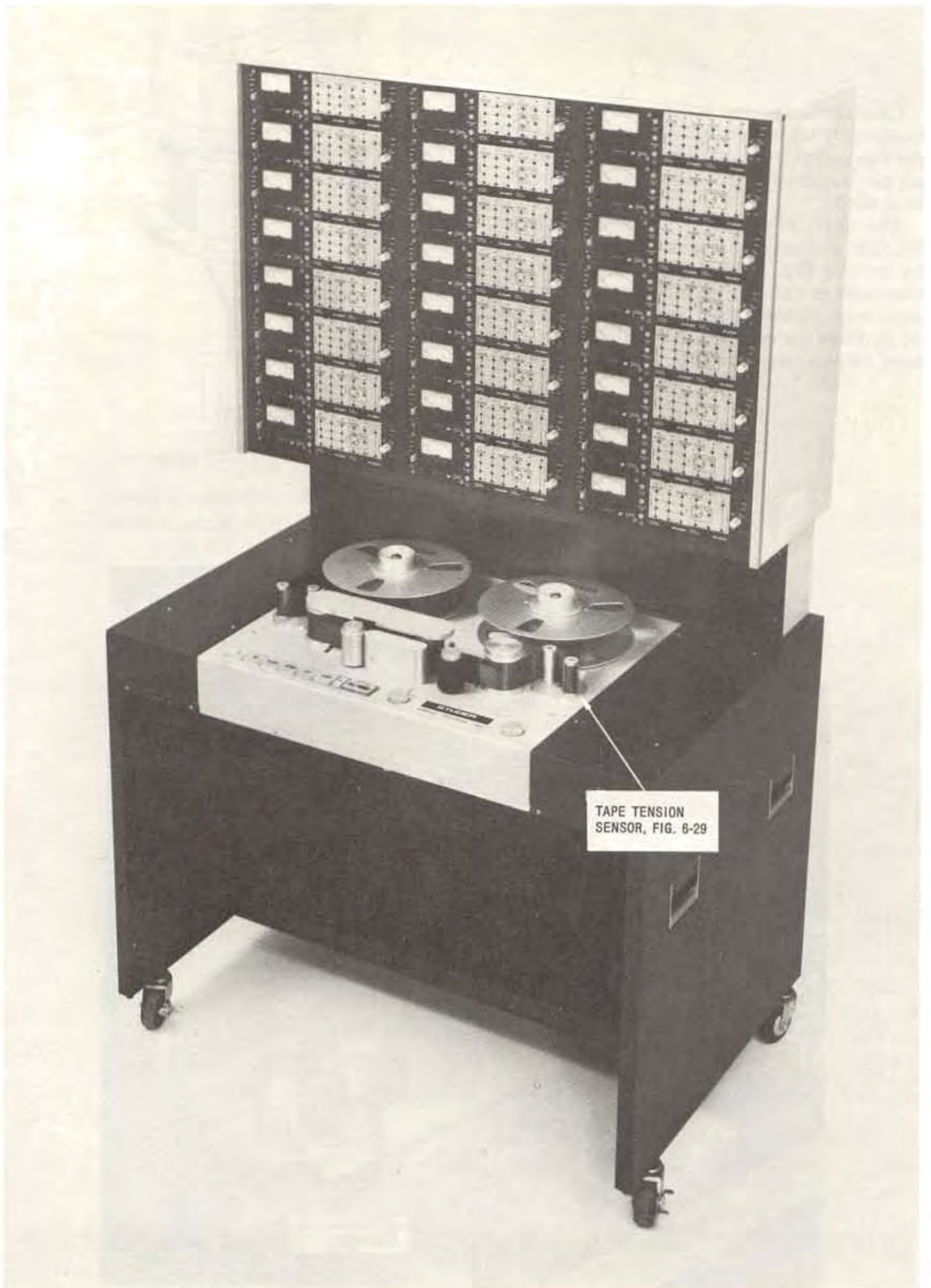
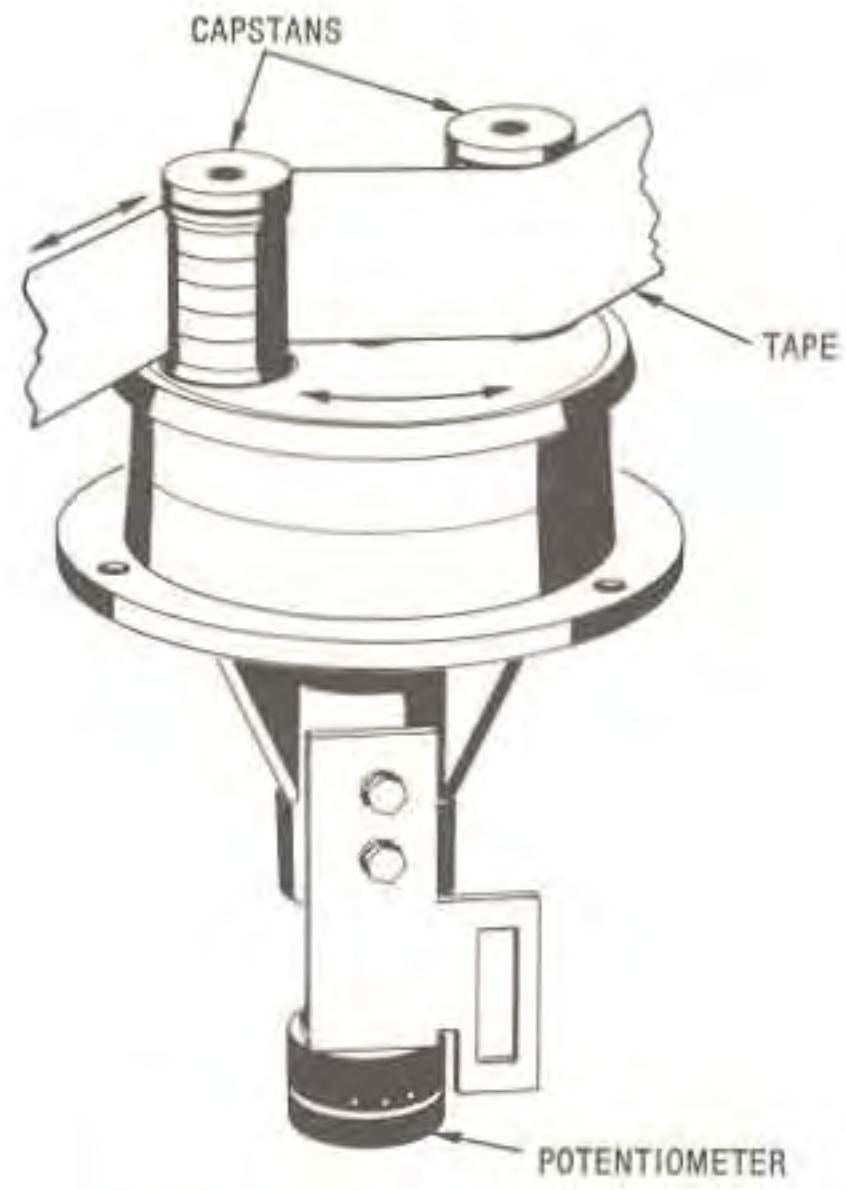

**Fig. 6-28** Multichannel magnetic tape recorder. (Willi Studer, Switzerland)



During the braking procedure, the take-up spooling motor is electronically controlled until the tape comes to a complete standstill. Thus, in all modes, the tape tension is electronically controlled.

The single turn precision potentiometers on the right and left tape tension sensors are shown by arrows Fig. 6-30. This is a view of the underside of the tape drive system and related electronics. Potentiometers with conductive plastic elements are used in this application because long, reliable, noise-free life is required.



**Fig. 6-29** A tape tension sensor (Willi Studer, Switzerland)

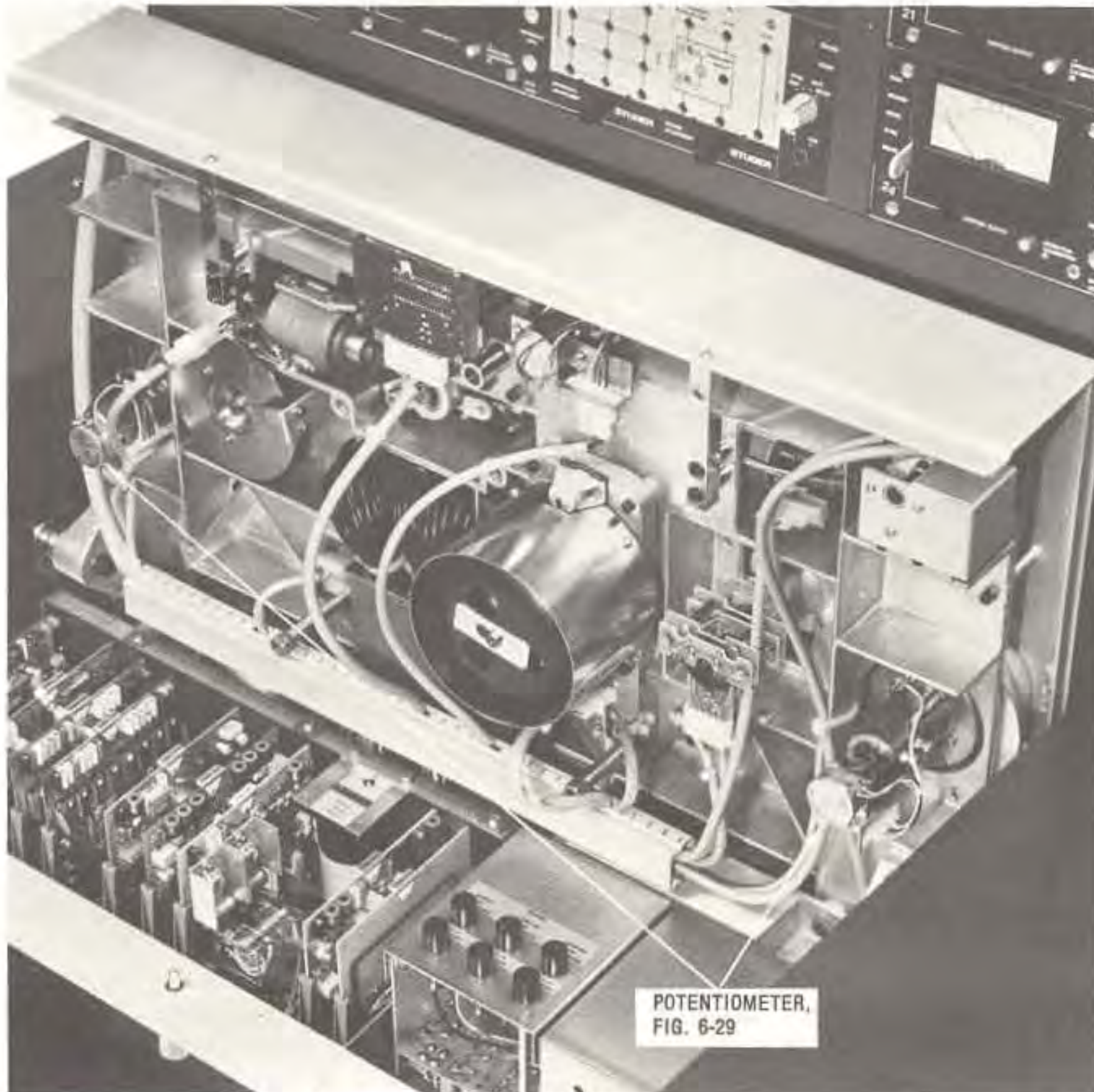

**Fig. 6-30** View of underside of tape drive mechanics and electronics (Willi Studer, Switzerland)



# CONSTRUCTION DETAILS AND SELECTION GUIDELINES



Chapter



*"I am not building for a day. The trouble with some American manufacturers is just that very point. They cater to the passing whim. It pays to make things slowly, but to make them right. It is one of the fundamentals of business success — not measured by standards of today, but by those of a century hence. There are no seconds or thirds going out of my shops. Nothing but firsts — first, last and all the time."*

*T. A. Edison*

*Quoted in Popular Electricity Magazine  
Vol. V, No. 7, November 1912*

## INTRODUCTION

There are five basic parts of any potentiometer:

- Resistive element
- Terminations
- Contact or wiper
- Actuator or shaft
- Case or housing

For each part there are several fundamental variations possible.

In this chapter the parts of a potentiometer are considered individually since each has special characteristics which offer an advantage or impose a limitation on the final assembly.

A careful study of the material presented will aid in the selection of the proper construction type for a particular application.

## RESISTIVE ELEMENTS

The real heart of any potentiometer is the resistive element. It affects, to some degree, all potentiometer electrical parameters. There are two general classifications of resistive elements — *wirewound* and *nonwirewound*. The nonwirewound group can be further classified as cermet, carbon, metal film, or bulk metal. It is also possible to combine wirewound and conductive plastic (a special carbon composition) in one element to achieve improved performance of certain electrical parameters. In addition, cermet and conductive plastic have been combined by at least one manufacturer. Both of these combination elements are discussed under *Hybrid Elements*.

**Wirewound Elements.** Resistance wire can be used to form the resistive element in a potenti-



ometer. Commonly used materials are one of three alloys:

- Nickel-chromium
- Copper-nickel
- Gold-platinum

Nickel-chromium (75% Ni, 25% Cr) is the most common. Its temperature coefficient is typically less than  $\pm 5\text{ppm}/^\circ\text{C}$ . It has a resistivity of 800 ohms per circular mil foot. A circular mil foot (cmf) is a hypothetical quantity equivalent to one foot of wire that is one thousandth (.001) of an inch in diameter. Popular use of Ni-Cr resistance wire for resistive elements is largely due to its excellent TC and availability in many different diameters. The broad size range results in a wide selection of TR values with very low ENR ratings.

Copper-nickel (55% Cu, 45% Ni) wire has a resistivity of 300 ohms/cmf and a temperature coefficient of  $\pm 20\text{ppm}/^\circ\text{C}$ .

A less common material for resistive elements is a complex precious metal alloy of gold (Au) and platinum (Pt) together with small amounts of copper (Cu) and silver (Ag). The resulting resistivity is approximately 85 ohms/cmf with a high temperature coefficient of  $+650\text{ppm}/^\circ\text{C}$ . This sacrifice in temperature coefficient results in an improvement in certain other parameters. For example, low resistivity and the ability to withstand harsh environments without oxidation of its surface. This helps keep wiper noise low even in severe environments.

Figure 7-1 lists the resistivities for various diameters of the three different resistance wire alloys. This is a partial listing. Other wire sizes are available.

DIAMETER (inches)	RESISTANCE (OHMS PER FOOT)		
	Ni-Cr	Cu-Ni	Au-Pt-Cu-Ag
0.008	12.50	4.69	1.33
0.005	32.00	12.00	3.40
0.002	200.0	75.00	21.25
0.001	800.0	300.0	85.00
0.0008	1250	468.8	132.8
0.0005	3200	1200	340.0
0.0004	5000	1875	531.3

Fig. 7-1 Relation of Resistance to Wire Diameter

Basically, the actual wire used depends upon the total resistance required, the resolution needed, and the space available. Smaller wire allows higher resistance in a given space and improved resolution. However, smaller wire is more fragile and therefore, difficult to wind. Power and current carrying requirements also influence the choice of resistance wire size.

Although it is possible to have a simple single straight wire element, such construction is impractical. As an illustration, assume the highest resistivity wire, listed in Figure 7-1, was used to construct a 5000 ohm resistive element. The finished potentiometer would be greater than one foot in length. The common construction technique for a resistance wire element requires many turns of resistance wire carefully wound on a carrier form or mandrel. This method allows a substantial resistance to be packaged in a small volume. A ceramic or plastic mandrel can be used. However, the most common type of mandrel is a length of insulated copper wire. After winding, this flexible carrier form can be coiled in a helical fashion to further compress the length required for the resistive element.

The copper wire mandrel has several practical advantages. It is available in precise round cross sections in long lengths and can be purchased with an insulating enamel already applied. These characteristics contribute toward high quality elements at relatively low manufacturing costs.

The characteristics of the mandrel are very important. Irregularities can make winding difficult and result in poor linearity and/or poor resolution. Mechanical instabilities can lead to undesirable stresses in the wire or loose windings which allow individual turns of wire to move. The advantages gained by using a resistance wire with a carefully controlled temperature coefficient will be lost if the mandrel expands and stretches the wire to produce substantial resistance changes with varying temperature. This is known as the *strain gage* effect. It occurs when the wire is stretched thus reducing its cross section and increasing its resistance. Any unbalance in coefficients of expansion between the resistance wire and mandrel can cause an intolerable variation in resistance due to temperature changes.

For accuracy and economy, high speed automatic machinery may be used to wind the element wire on long mandrels. These are cut to the proper lengths and installed in individual potentiometers at a later manufacturing phase. The photograph of Fig. 7-2 shows a machine which produces a continual helix of wound element. This element may be cut into individual rings for single turn potentiometers or helical elements for multiturn units. The very delicate resistance wire must be wound on the mandrel in a manner that produces uniformity and the right amount of total resistance in the exact length required. Irregularities in the winding process can result in a broken wire or overlapping turns. If the winding tension (the pull against the resistance wire as it is wound on a mandrel) is not just right, the turns of resistance wire will be loose



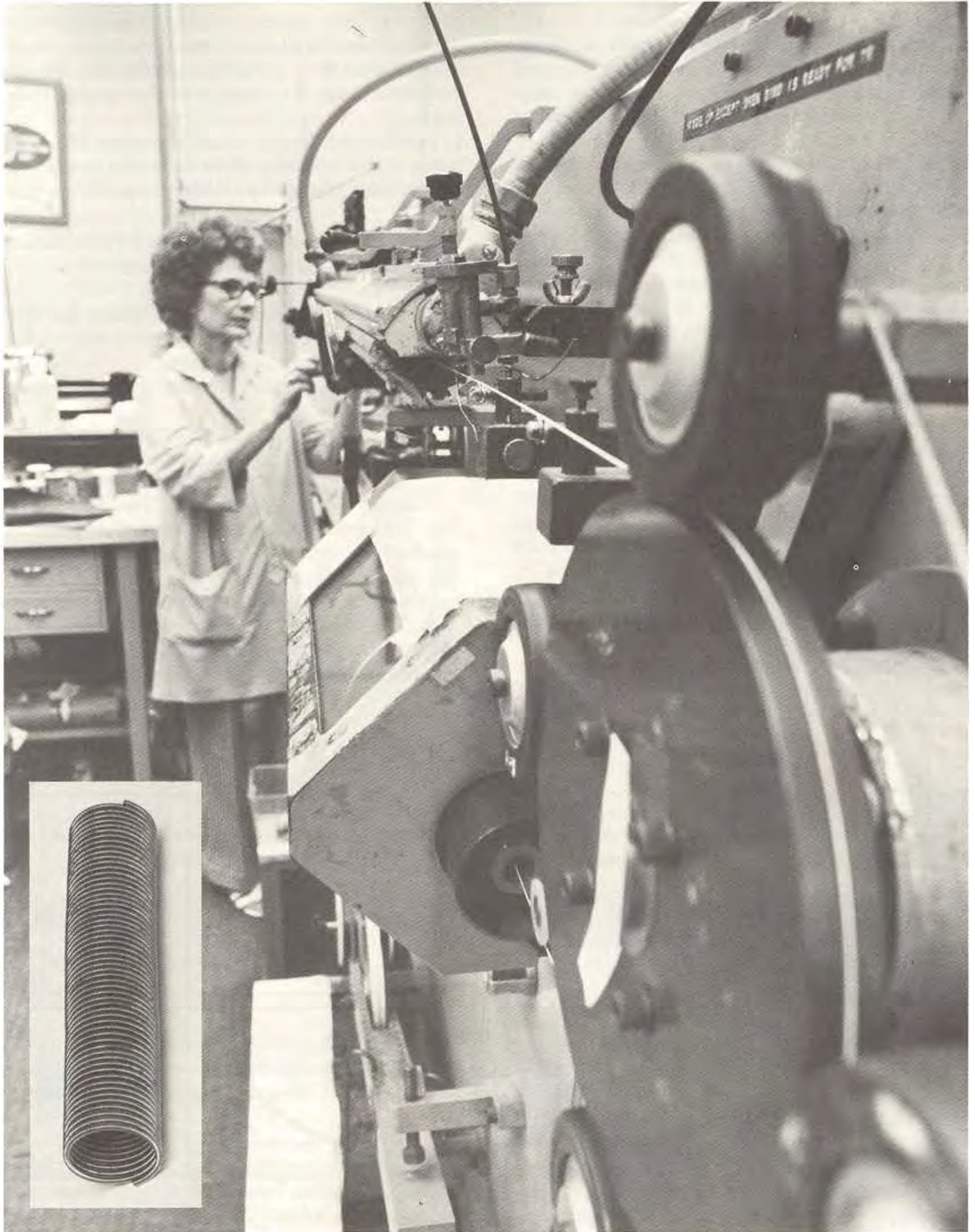

**Fig. 7-2** An automatic machine used to produce a continual helix of resistance element (inset)



or over-stressed and the resulting element will exhibit a poor temperature coefficient.

Many factors are involved in the winding operation. These may not be obvious to the end user but are a major concern of every potentiometer manufacturer. The critical potentiometer buyer will be wise to compare the capability of various manufacturers before choosing a source.

The temperature coefficient of the finished potentiometer will be much poorer than that of the unwound, unstressed resistance wire. It is unfortunate for the circuit designer that data sheets for some wirewound potentiometers list temperature coefficient using values of the unwound resistance wire alone. If such a specification is listed, *never* make the assumption that this is the temperature coefficient of the completed potentiometer. Instead, check with your potentiometer source.

Potentiometers designed for high power, rheostat applications often use an insulated metal mandrel. This provides an excellent thermally conductive path for the heat generated within the resistance winding. The metal mandrel allows an increase in the power rating, compared to plastic or ceramic, which is especially significant in applications where power is dissipated by only a portion of the element.

In most cases, the unwound resistance wire is bare with no insulation. A slight amount of cement is used to bond the wire to the mandrel.

Too much cement will interfere with the wiper path; too little results in loose turns. Since the tolerance on the unformed resistance wire often approaches the total resistance tolerance for the completed unit, it is easily seen that quality is no accident.

**Nonlinear Wirewound Elements.** One or more of the following methods is used to achieve a nonlinear change in resistivity,  $\rho$ , with wiper travel.

- 1) A carefully shaped mandrel cross section to vary the resistance increment from one turn to the next.
- 2) Careful variation in the winding pitch to change the number of turns traversed for a given mechanical travel.
- 3) A change in the wire size and/or the wire material.
- 4) A combination of 2 and 3 above.
- 5) Carefully positioned taps to permit the addition to external connections.

*Varying the mandrel shape.* The drawing of Fig. 7-3 shows a variety of elements designed to produce different nonlinear functions. The winding mandrel is designed (shaped) to vary the resistivity in a nonlinear manner from turn to turn. The mandrel must be constructed such that the resistivity varies at the desired rate of change of  $f(\theta)$ . Mathematically:

$$\Delta\rho = \frac{d}{d\theta} f(\theta)$$

$f(\theta)$	RESISTANCE FUNCTION	MANDREL PROFILE	$f(\theta)$	RESISTANCE FUNCTION	MANDREL PROFILE
$k\theta$		 $\frac{d}{d\theta} f(\theta) = k, \text{ a constant}$	$k \sin \theta$		 $\frac{d}{d\theta} f(\theta) = k \cos \theta$
$k\theta^2$		 $\frac{d}{d\theta} f(\theta) = 2k\theta$	$k e^\theta$		 $\frac{d}{d\theta} f(\theta) = k e^\theta$
$k\theta^3$		 $\frac{d}{d\theta} f(\theta) = 3k\theta^2$	$k/n\theta$		 $\frac{d}{d\theta} f(\theta) = k \frac{1}{\theta}$

Fig. 7-3 A variety of mandrel shapes to achieve various output functions



The limits of the individual functions in Fig. 7-3 are determined by the steepness of mandrel slope and the ratio of maximum to minimum mandrel width. These ratios and thus mandrel slope ratios normally do not exceed 5:1. This is because of the practical maximum limitations of 20° mandrel slope and a 5:1 ratio of maximum to minimum mandrel width. Greater slope ratios are possible using other approaches described in the paragraphs that follow.

The slope ratio needed to yield a specified nonlinear function is not always the only indicator of the degree of difficulty of producing the function. For example, the two functions shown in

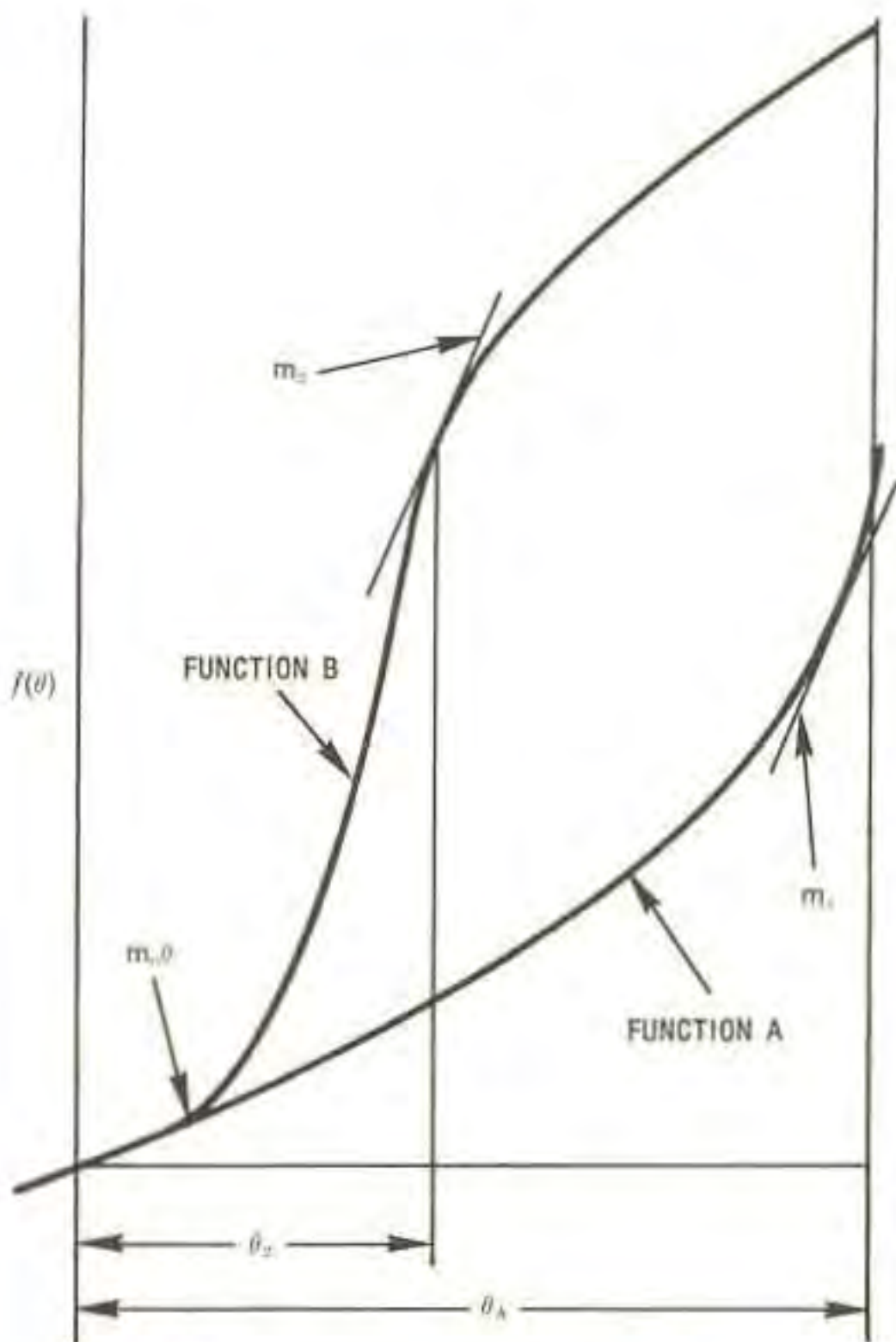

**Fig. 7-4** Output functions with the same slope ratio may require different construction methods

Fig. 7-4 illustrate entirely different winding problems even though their slope ratios are identical. The two curves of Fig. 7-4 have equal slope ratios since the maximum slopes  $m_1$  and  $m_2$  are equal. Function B is more difficult to wind because the slope ratio must be achieved within the relatively small travel distance  $\theta_2$ .

In Fig. 7-5 each straight line segment of the output acts as a linear potentiometer when the mandrel is stepped as shown. If the resistance

wire is uniformly spaced over each linear section the corresponding output of each will have a different slope. This is because the rate of change in  $f(\theta)$  from turn to turn of resistance wire is greater if the mandrel is wider since the length of resistance wire is also greater.

The stepped mandrel is often a practical method to produce nonlinear wirewound resistance elements even though its straight sections may only approximate a nonlinear function. Closely spaced function changes are possible. Problems of securing wire to sloped mandrels are eliminated by use of stepped elements.

*Varying the winding pitch.* Changing the resistivity  $\rho$  in a nonlinear manner by altering the spacing between individual turns of the element is possible. Winding machines employing special servo techniques are available for controlling the

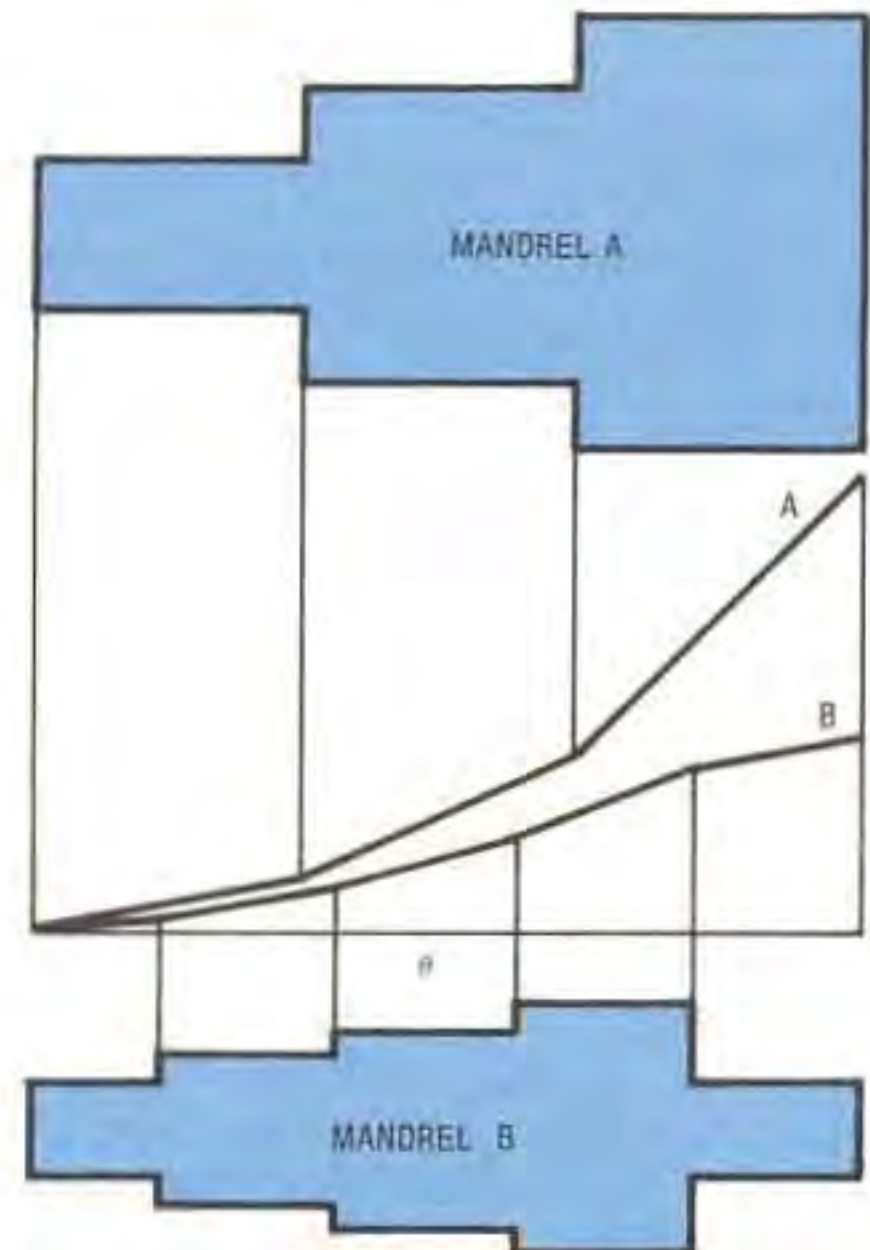

**Fig. 7-5** Examples of stepping mandrel to change slope of output

winding spacing in a smooth fashion. This method is limited by the fineness of the wire that can be wound (the closeness of the turns at the *tight* end of the mandrel), and by the maximum wire spacing that can be tolerated (the resolution limit at the *loose* end of the mandrel). In practice, a 4:1 ratio in wire spacing is considered maximum.

*Changing the wire.* The range of achievable functions can be extended by changing wire size or material whenever one of the limitations is reached. In applications where the resolution



must be essentially constant over the entire element length, multiple materials must be used.

In Fig. 7-6, the mandrel perimeter, winding space and wire size are held constant. By splicing different wires as shown and changing only the resistivity of the resistance wire, various slope

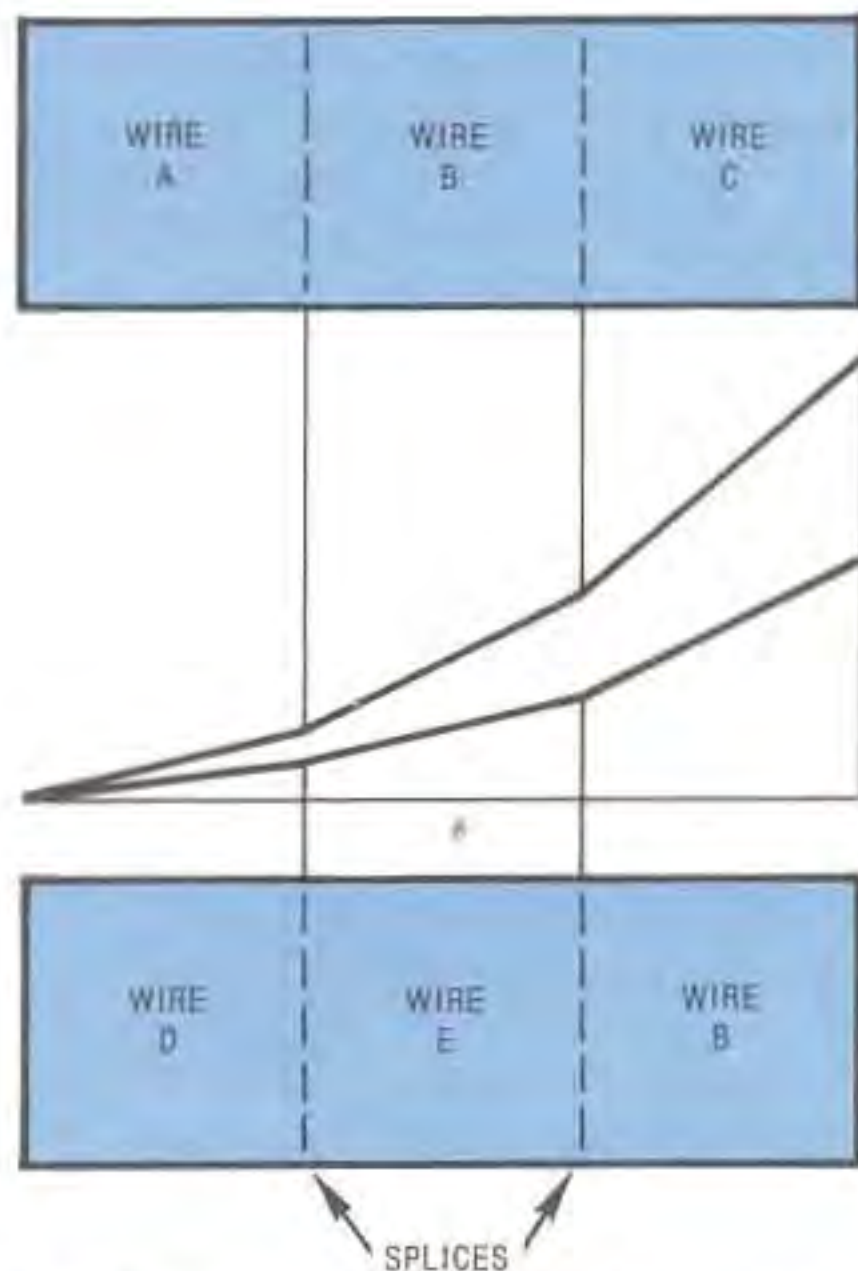

Fig. 7-6 Two examples of how change in wire resistivity changes slope with identical mandrel

ratios are possible. Thus, the slope of the straight-line output of each of the three sections of the element is directly proportional to the resistivity of the wire. The maximum practical slope ratio is 16. This is based on the ratio of maximum to minimum resistivity per unit length of winding using common resistance wire types. These range from 60 to 1000 ohms per circular mil foot depending on composition.

As discussed earlier in this chapter, choices of resistance wire compositions are limited by performance requirements including TC, life and noise. Most manufacturers use a limited number of wire types in a single wirewound element because of the cost of splicing. Instead, they stock a wide variety of wire sizes.

Slope ratio functions of 100:1 are possible by changing only wire size which ranges from less than .001 to .010 inches in diameter. As before, each change in wire size on an element requires a wire splice.

*Varying winding pitch and wire.* Control of resistivity can be maximized by varying wire spacing and wire size.

By using both .001" and .010" wire the maximum slope ratio possible with the same winding factor can be illustrated. Winding factor is the ratio of the number of turns per inch of mandrel that are actually wound to the maximum number that can theoretically be wound if turns are butted together. A maximum winding factor of 0.75 is normally practical for flat mandrels that are to be curved into a circle. This leaves enough space between turns so that turns of wire will not short together after the element is curved.

Assuming the winding factor is constant, ten times more .001" diameter wire can be wound per inch of mandrel as .010" diameter wire. Also .001" diameter wire has 100 times the resistivity of .010" diameter wire. By combining these extremes (10x100) a 1000:1 slope ratio is possible in a single resistive element. One shortcoming of this example is the relatively poor resolution of the .010" wire compared to .001" wire. When resolution is a factor then different wires should be considered to minimize the sacrifice in resolution with high slope ratios.

*Tapping.* Tapping is required when the function must go through an inversion as in the case of the sine function of Fig. 7-7. If the sine potentiometer were not tapped, the output function  $\frac{E_o}{E_i}$  would follow its conventional curve over the first 180° of input rotation, but would continue upward as shown in Fig. 7-7A. The desired sine function is achieved by:

- 1) Providing a tap at the mid-point of the element and connecting this tap to one side of the excitation source,  $E_1$ .
- 2) Connecting the potentiometer end terminals to the other side of the excitation source.

The use of tapping to achieve difficult nonlinear functions together with other methods are covered more extensively in Chapter 6.

*Selection factors.* Wirewound potentiometers offer very good stability of total resistance with time and temperature changes. Stability can be better than 0.01% in 1000 hours of operation. Additionally, these elements offer low noise in the static state, high power capabilities, and good operational life.

Wirewound elements do not offer as wide a selection of TR values as some other types; but, the range in trimmers is from 10 ohms to 20K ohms. Some manufacturers offer values as high



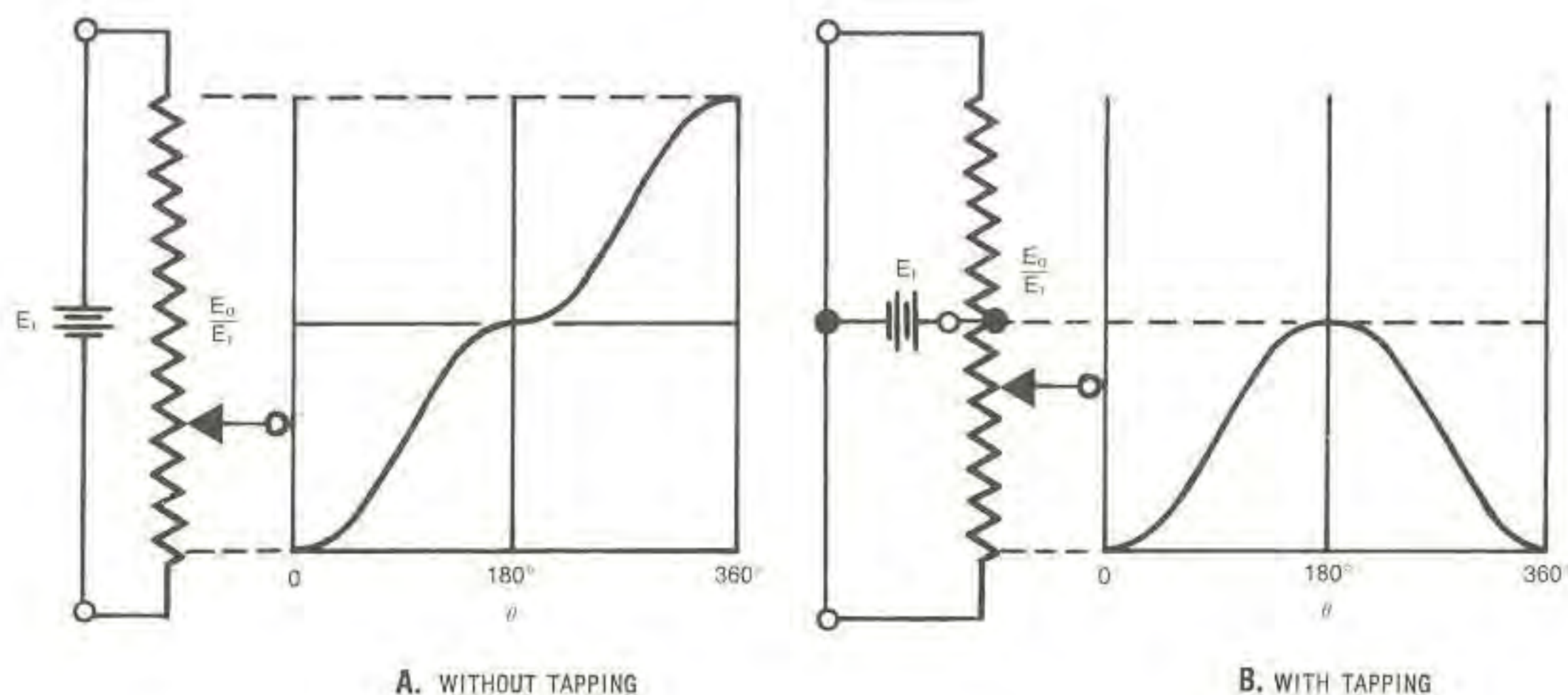

Fig. 7-7 Use of tapping to achieve inversion of the sine-wave function

as 100K ohms at premium prices. Precisions are available with total resistances as low as 25 ohms and as high as 500K ohms.

One of the primary limitations of wirewound elements is the finite resolution steps which result from the wiper moving from turn to turn. These steps are distinct, sudden, repeatable changes in output. They may be as great as the resolution specification ( % of total resistance) but are often less because of the bridging action of the wiper between turns. In systems that might be sensitive to such discrete steps, care should be taken to select a potentiometer with resolution good enough (small enough) to avoid difficulty.

The use of wirewound elements should be avoided in high frequency applications. The many turns of resistance wire exhibit an inductive reactance with increases directly with frequency. This effect is most noticeable in low total resistance potentiometers because the inductive reactance can be larger than the resistance, even at frequencies as low as 20kHz.

Performance of wirewound potentiometers is also affected by inherent capacitance. Capacitance exists from turn to turn and also between the winding and mandrel. Capacitance effects are most significant in high total resistance potentiometers that usually have more turns of wire.

**Nonwirewound Elements.** Variable resistive devices that are not made with resistance wire are categorized by the industry and military as *nonwirewound*. These element types are discussed in individual sections below.

**Cermet resistive elements.** One of the more recent materials developed combines very fine

particles of ceramic or glass with those of precious metals to form a *ceramic metal* resistive material after firing in a kiln. *Cermet* is a term which may be applied to a wide range of materials as manufactured by different sources. Do not assume that all cermet potentiometers are the same. The comments included in the following paragraphs apply to cermet elements made by most manufacturers. Major manufacturers painstakingly compound, and carefully control, the composition of their cermet materials and processes. These are usually considered proprietary for competitive reasons so exact materials and details of manufacturing techniques are often closely guarded.

Cermet, also known as *thick film*, is defined as resistive and conductive films greater than .0001 inch thick, resulting from firing a paste or *ink* that has been deposited on a ceramic substrate. Similar materials and techniques are used to manufacture hybrid circuits and fixed resistor networks. For potentiometers, the condition of the *surface* of the film relative to wiper action (conductivity and abrasiveness) is a major concern.

The paste is applied to a flat ceramic substrate, usually alumina or steatite, by a *silk* screening operation. This is a mechanized precision stenciling process which uses screens of stainless steel or nylon. The ink is forced through the screen by a hard rubber squeegee. The drawing of Fig. 7-8 is an example of the screening process which applies the cermet ink to the ceramic substrate.

The shape of the element is controlled by



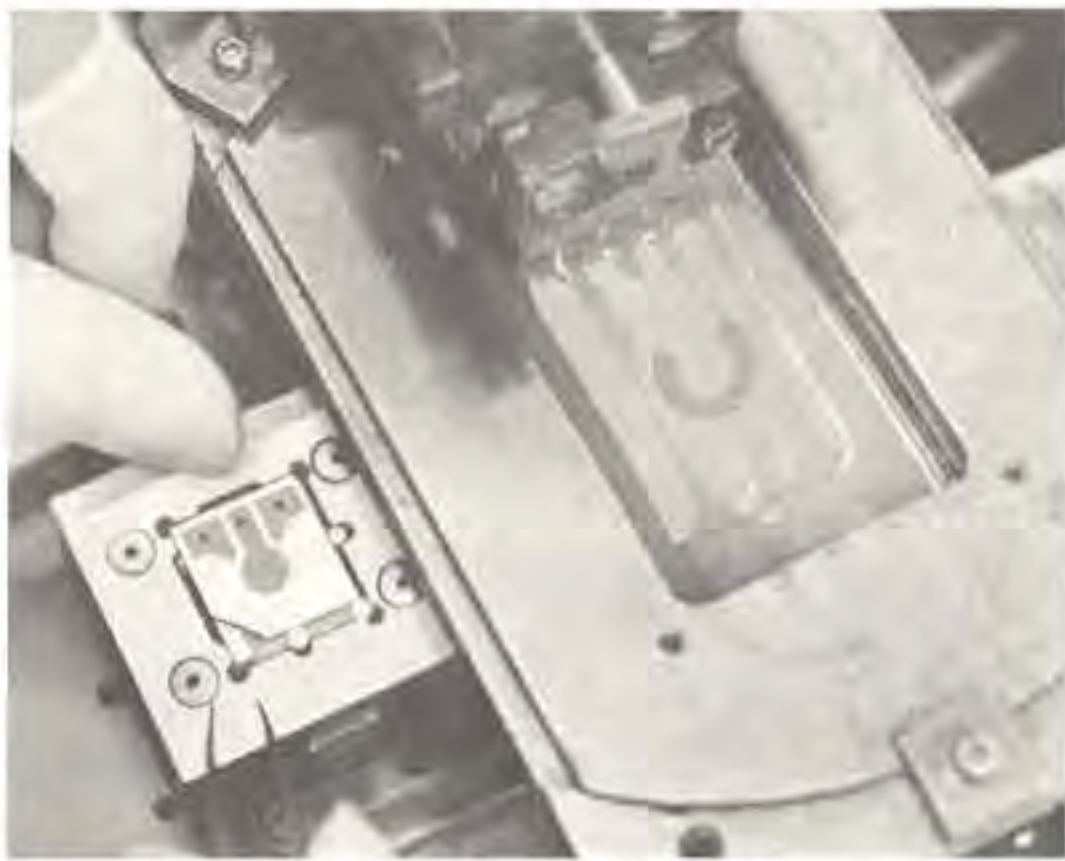

A.



B.



C.

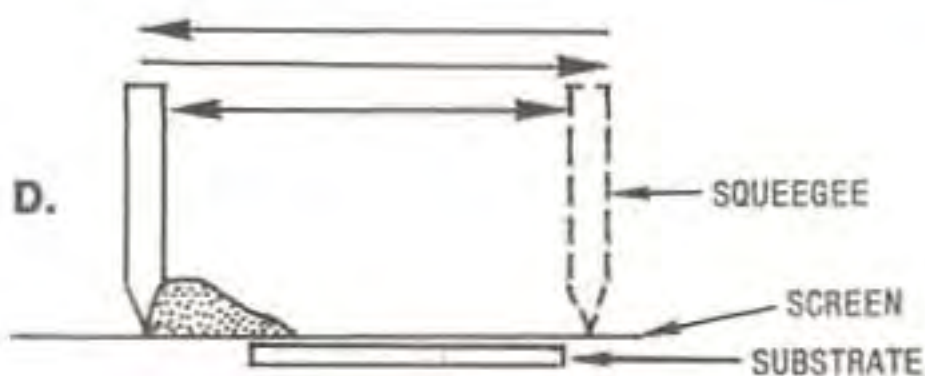

Fig. 7-8 Screening process for cermet element

small openings in the fine mesh screen that correspond to the desired pattern. The pattern of the screen openings is produced by a photographic process from a large scale artwork master. This process allows great versatility and provides high precision in screen production.

Composition of the resistive inks varies according to desired results. They all can be described as being composed of finely powdered inorganic solids (metals and metal oxides) mixed with a powdered glass binder (glass frit) and suspended in an organic vehicle (a resin mixture). Materials used include silver, palladium, platinum, ruthenium, rhodium, and gold.

Printing and firing of the inks is preferably done in a humidity and temperature controlled environment. This provides the best control of total resistance and temperature coefficient, and results in high yields and superior properties. A controlled temperature kiln with various temperature zones between 800°C and 1200°C is used to burn off the organic vehicle and causes a fusion of the glass particles with the ceramic substrate. The metallic particles provide a resistive film which is bonded to the substrate. Fig. 7-9 shows a kiln used to fire (glaze) the material.

A very wide range in resistance values can be achieved by varying:

- 1) The composition of the resistive ink.
- 2) The firing parameters (time and temperature).
- 3) The physical size of the element.

By using a substrate with good thermal characteristics, it is possible to get good power dissipation characteristics in a small space. In the single turn unit pictured in Fig. 7-10, the substrate is attached to the shaft in order to improve power dissipation. In this design a heat sink path is provided from the resistive element through the substrate, shaft, and bushing to the mounting panel.

The family of electronic ceramics includes steatite, forsterite, porcelain, zirconia, alumina, beryllia, and many other complex oxide ceramics. Of this family, the two most widely used materials are steatite and alumina.

Steatite is made from raw materials including talc (a mined inorganic material containing a major amount of magnesium oxide and silicon dioxides, plus a small amount of other oxide impurities), a stearate (lubricant), waxes (binder), and water. Alumina is made from high-purity aluminum oxide, talc, stearate, waxes, and water.

The two materials are processed from the raw





Fig. 7-9 The cermet ink is fired in a temperature controlled kiln

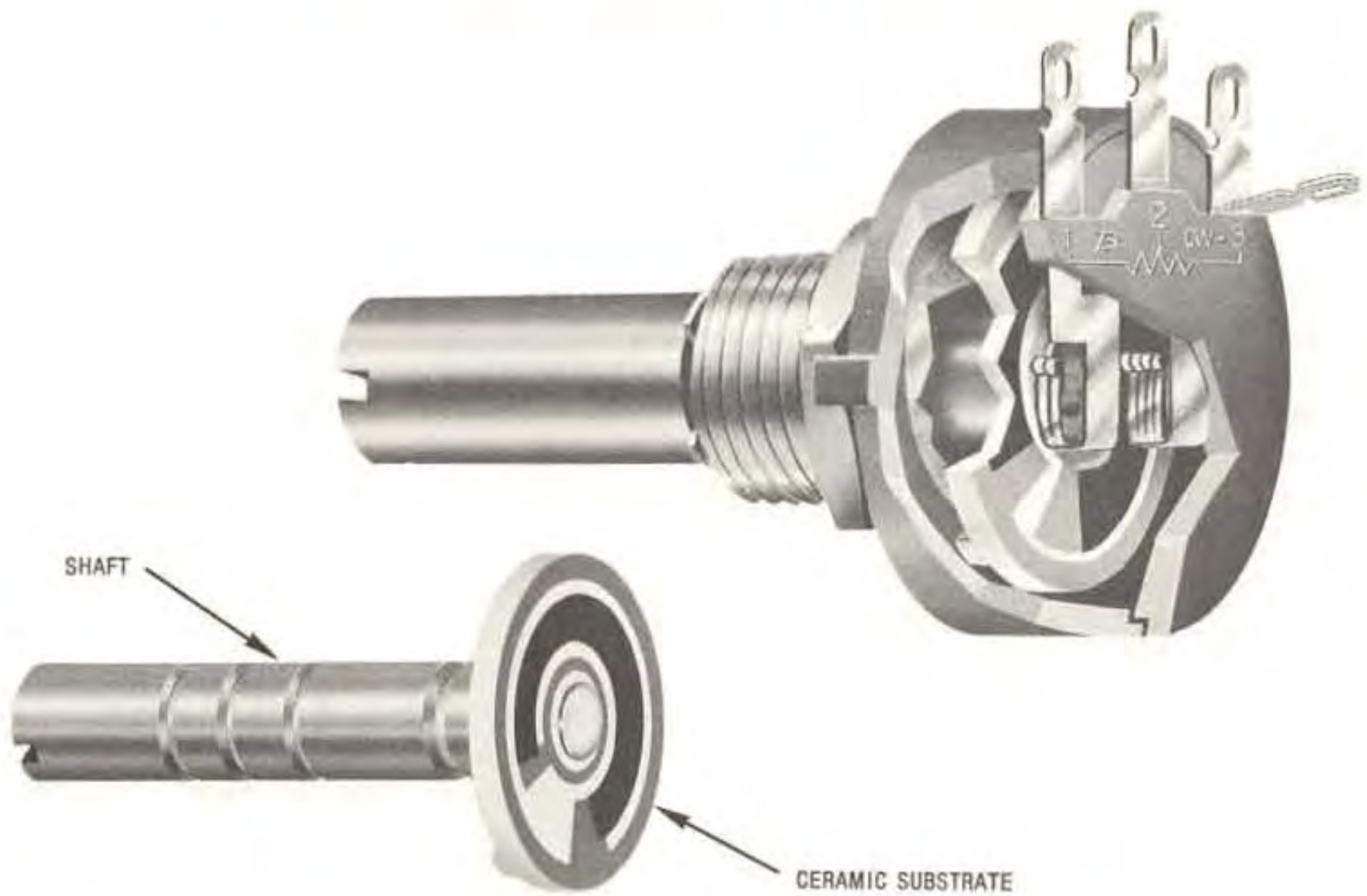

Fig. 7-10 In this design, a ceramic substrate is attached directly to the shaft in order to increase power dissipation capability



state to a useable powder form in a similar manner. The process includes mixing, ball milling, sizing and drying, plus blending. Each step contributes to producing a dry powder with repeatable characteristics such as particle size distribution, bulk and tap densities—the latter being checked after the bulk material is vibrated and settles.

The ceramic substrates (or bases) can be formed by various methods. These include dry powder pressing, extruding, isostatic pressing (pressed from every side), casting (doctor-blade process), and injection molding. The most common process is dry powder pressing. A carefully controlled amount of the dry powder is placed in a steel and/or carbide die cavity and pressure is applied from either the top or the bottom or both. The pressure compacts the powder into a *green* (unfired) part. The green part is then fired in a high temperature kiln from 1300°C to 1760°C.

Firing the substrate causes a shrinkage which can range from as little as 8% to as much as 20%. This firing (actually a sintering) produces substrates with uniform densities and adequate dimensional tolerances.

Tight controls on batch processing, pressing parameters, and firing profiles (various temperature zones) produces substrates whose tolerances are held to thousandths of an inch. Fired surfaces can be improved as required by the processes of tumbling, lapping and/or grinding. Other forming methods such as extrusion, molding, and doctor-blade casting require a wet mix called a slip or slurry.

Many new materials and improvements in processing have been developed in the past ten years to allow production of economical, highly reliable substrates.

**Selection factors.** Potentiometers having a total resistance from 10 ohms to 10 megohms are practical. However, the entire resistance range is not available in all possible sizes and configurations.

Cermet elements offer very low (infinitesimal) resolution and good stability. Their noise performance is good in both the static and dynamic (CRV) condition.

Frequency response of cermet materials is very good and the practical application range extends well beyond 100MHz. The lower resistivity materials exhibit an equivalent series inductance, while the higher resistance cermets display an equivalent shunt capacitance.

Temperature coefficient for cermet potentiometers range from  $\pm 50$  ppm/°C to  $\pm 150$  ppm/°C, but average  $\pm 100$  ppm/°C or better depending on resistance range.

Operational life of cermet elements is excel-

lent. The element surface is hard and very durable. Failures of cermet potentiometers, after extended mechanical operation, are more often wiper failures due to wear than problems in the element.

For trimming applications, cermet elements usually offer the best performance per dollar per unit space. Even though cermet elements are more abrasive than conductive plastic, wiper wear is low enough that mechanical life far exceeds trimmer requirements.

**Carbon elements.** Early carbon film potentiometers were usually made with a mixture of carbon powder and phenolic resin applied to a phenolic substrate and cured. Dramatic improvements in materials technology over the years have resulted in an upgrading of substrates and carbon-plastic resin compounds. One early improvement was the use of ceramic as a substrate for elements made of carbon and phenolic resin.

Depending on desired end results, a carbon composition element may be screened on (as with cermet), brushed on, sprayed on, applied with a transfer wheel, or dipped onto an insulative substrate. When sprayed onto a substrate, an automatically controlled spray gun is swept back and forth. Controlling the sweep speed determines the thickness of the resistive material which influences the resistivity of the element. A mask (stencil) may be used to control the resistive pattern.

The processing of all nonwirewound elements requires a manufacturing environment which is free from dust and other foreign particles. Foreign particles settling on a wet resistive film will interfere with stability, contact resistance variation and the element's total resistance.

After the resistive material is applied to the substrate, the resistance elements are transferred to an oven for curing. The procedure may be done by static oven batch curing or by infrared curing. During curing, the solvents are driven off and the organic resin cross links to form a durable plastic film. The resistivity increases with time or temperature. This increase in resistivity is predictable and may be compensated for during preparation of the carbon composition material. The finished element has characteristics similar to a carbon-film fixed resistor.

Various techniques are available for changing the resistivity of the elements. In addition to the amount of carbon, small quantities of powdered metals, such as silver, are sometimes used. The metals, being conductors, lower the resistivity and cause the temperature coefficients to become more positive. Altering the element geometry and placing shorting conductors under the element are two other methods which may be used to change the resistivity.



Potentiometers made with *molded carbon* are manufactured by molding a previously formed resistance element and other parts of the potentiometer together. These molded units are sometimes called hot molded carbon and are comparable to the carbon-pellet type of fixed resistors. The hot molded carbon element provides definite improvements in mechanical life and TC compared to ordinary carbon film elements.

Conductive plastic, the modern carbon film element, is made with one of the more recent plastic resins such as epoxy, polyesters, improved phenolics, or polyamides. These resins are blended with carefully processed carbon powder and applied to ceramic or greatly improved plastic substrates. The result is superior stability and performance. The importance of plastics technology to these improvements has probably been the reason for acceptance of the term *conductive plastic* or *plastic film* element.

Conductive plastic elements may vary considerably in temperature coefficient (TC). The resistivity range, ambient temperature range, materials preparation procedures, substrate material, and the curing techniques all influence the TC quality. TC values of  $-200$  ppm/ $^{\circ}\text{C}$  may be attained by optimizing the processing techniques

of carbon or by incorporating metal powders or flakes into the system. Nickel, silver, and copper are most frequently used. However, these low TC's are usually found in the low resistivity ranges.

The substrates used may be either ceramic or plastic; however, modern plastic substrates result in better temperature coefficients due to the greater compatibility of the ink and the substrate.

For thinner films than those obtained with application methods mentioned above, carbon may be applied by vapor deposition. This method, while yielding an excellent fixed resistor, results in a film that is usually too thin to withstand wiper abrasion.

Conductive plastic material may also be deposited on an insulated metal mandrel and formed in a helix as shown in Fig. 7-11 for use in multi-turn potentiometers.

**Selection factors.** The carbon film potentiometer is usually the designer's first choice for an economical way to vary resistance in an electronic circuit. This is particularly true in commercial applications where specifications are less exacting and cost is a major concern. In addition to commercial applications, carbon film units with high quality elements and special construction techniques are also used in industrial and

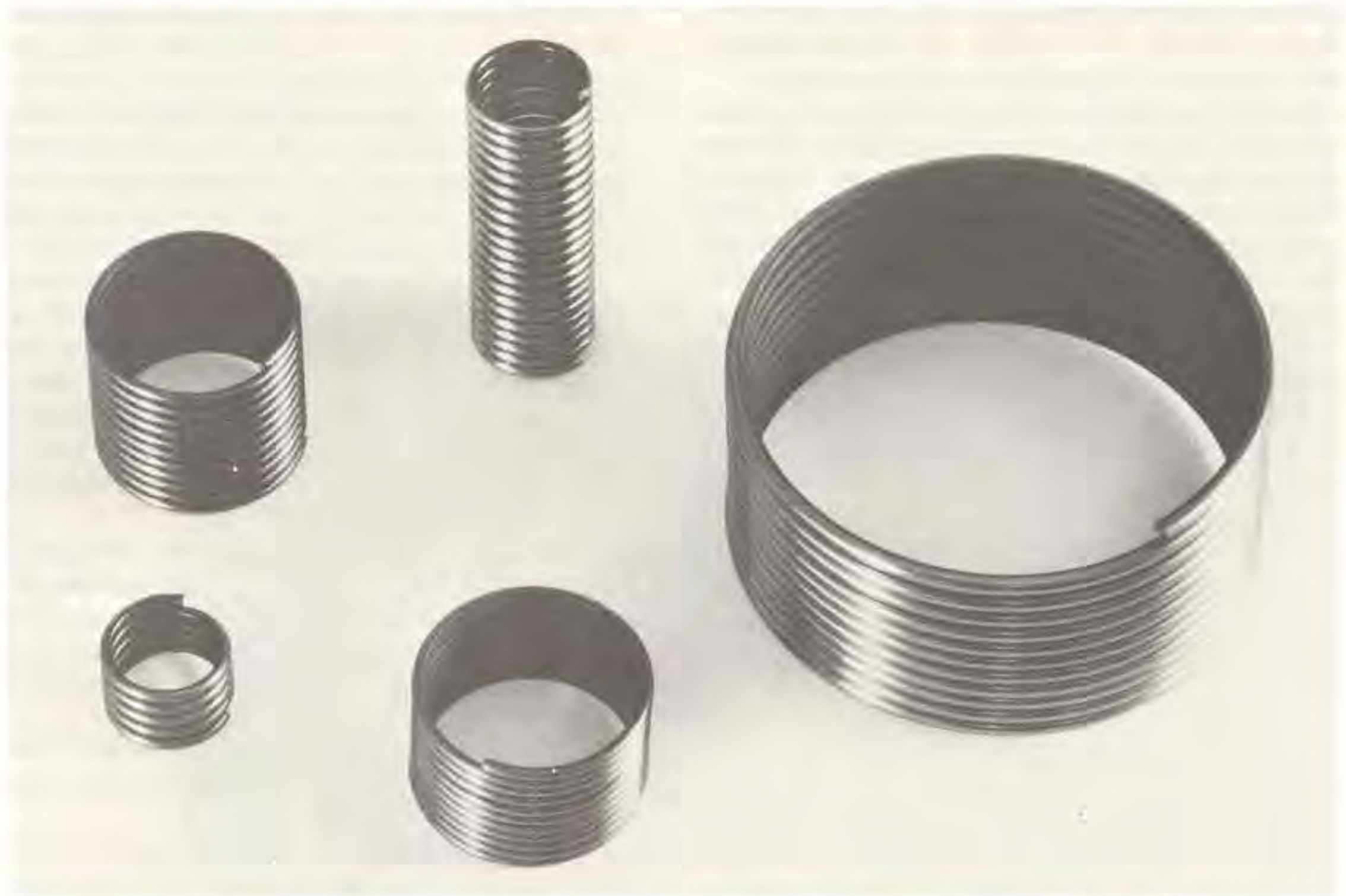

**Fig. 7-11** A conductive plastic film is applied to an insulated mandrel to provide an element for a multi-turn potentiometer



military equipment.

Advantages of carbon elements include low cost, relatively low noise during adjustment, and excellent high frequency performance. They also offer low inductive and distributed capacitive reactance. The operational life of carbon elements is very good and degradation characteristics are usually gradual rather than sudden catastrophic failures.

The resistive range of carbon elements extends as high as 20 megohms and as low as 10 ohms. Total resistance tolerance is typically  $\pm 10\%$ .

The presence of substantial contact resistance in carbon elements limits applications where even moderate wiper current will be present. End resistance is usually high.

Carbon elements typically have poor moisture resistance and the load stability is not as good as cermet. Molded carbon elements can be expected to shift as much as 5% in a year. Although the carbon element has no resolution-type noise, the noise level at best can be quite high.

The outstanding characteristics of a conductive plastic element are low cost, low contact resistance variation, and extensive rotational life. The smooth surface produces extremely low resolution with virtually no friction or wear, even after a few million cycles of the wiper over the element. Linearities approaching those of wirewound elements are possible by blast trimming the elements with an abrasive after curing.

The temperature coefficient of carbon is negative. The magnitude of the TC differs for the various types of carbon potentiometers. Molded carbon units may exhibit a TC range of  $-2000$  ppm/ $^{\circ}\text{C}$  to  $-8000$  ppm/ $^{\circ}\text{C}$  whereas deposited carbon elements show TC's of about  $-1000$  ppm/ $^{\circ}\text{C}$ . Temperature coefficients as low as  $-200$  ppm/ $^{\circ}\text{C}$  are available in conductive plastic units.

The dynamic noise of conductive plastic potentiometers is quite low. This feature, coupled with the excellent resolution, permits the use of conductive plastic potentiometers in high-gain servo systems where other element materials would be unusable.

Conductive plastic elements offer good high frequency operation. No coils are present in the flat pattern design to produce inductive effects and the helical construction produces negligible inductive reactance. However, when the conductive plastic element is deposited on an insulated metal mandrel for multiturn potentiometers, some distributed capacitance is present between the element and the mandrel. This capacitance limits the high frequency performance of this construction very slightly.

Major limitations of conductive plastic

elements are low wiper current ratings, moderate temperature coefficient and low power capabilities.

**Metal film elements.** It is possible to vacuum deposit a very thin layer of metal alloy on a substrate to form a resistance element. Any metal which can be successfully evaporated or sputtered may be used, although only certain metals will yield the desirable characteristics of good temperature coefficient, useful resistivity, and a hard durable conductive surface. Typically, a member of the nickel-chromium alloy family is used to deposit a layer 100 to 2000 angstroms thick.

After deposition a very important part of the element processing is the stabilizing heat treatment. It is through precise control of this stage of manufacture that the complex strains inside the films are minimized. Carefully controlled processing makes it possible to achieve a temperature coefficient approaching wirewound elements. The uniformity of the process yields good linearity, extremely low resolution, and very low noise both at rest and during adjustment.

**Selection factors.** Due to their small size and construction, metal film elements are particularly low in reactive impedance. The housing and other packaging materials determine the effective parallel capacitance.

Metal film elements are practical only for lower resistance values. Total resistances are available from 10 ohms to 20K ohms. These elements are limited in power rating and have a rather short operational life. For these reasons, metal film elements are used primarily in those trimming applications where very low noise and good frequency characteristics are needed.

**Bulk metal elements.** Potentiometer elements may also be made with bulk or mass metal applied on a substrate in a much thicker layer than achieved by vapor deposition. One approach is a plating technique for a solid area of resistance metal, followed by precision photochemical etching of a zigzag pattern to increase the effective length of the element.

If the metal is carefully chosen to match properly with the substrate material the effective temperature characteristics of the two materials will compensate for each other. The result is an element with exceptionally low temperature coefficients.

**Selection factors.** Extremely low TC is the most significant advantage of bulk metal elements. Less than 10 ppm/ $^{\circ}\text{C}$  is possible.

Total resistances from 2 ohms to 20K ohms are obtainable in trimmer styles. For total resistances below 100 ohms a solid element may be used and the resolution is negligible. Larger resistance values require an etched pattern to in-



crease the effective length of the element. This causes resolution to increase.

Contact resistance for bulk metal elements is very low but if an etched pattern is required, adjustment noise may be much higher.

Frequency response is excellent. The distributed capacitance is very low and inductance is negligible in either the etched or unetched pattern.

The limitations of bulk metal elements are cost, resolution in the higher TR values, and mechanical life. Their most frequent use is in trimmer applications where ambient temperature change is a critical factor.

**Resistance taper.** Resistance taper, as defined in Chapter 5, is the output curve of resistance measured between one end of the element and the wiper. It is expressed as a percentage of total resistance.

To achieve a given resistance taper, manufacturers vary the geometry of the element or the resistivity of the element material or both. This technique produces an element which is a linear approximation of the ideal theoretical taper and conforms to military and commercial specification tolerances. Fig. 7-12 shows three resistance tapers in MIL-R-94B. Fig. 7-13 shows a comparison of a linear approximation element and the ideal audio taper C of Fig. 7-12. Fig. 7-14 is a sampling of various film elements designed to provide a resistance taper.

A closer approximation to the ideal taper is possible with certain construction methods. An example is the molded carbon element which allows tight control of the element cross section. This can be made to conform to a given taper with a high degree of accuracy.

**Selection factors.** Taper A in Fig. 7-12 provides a rate of resistance change that is directly proportional to shaft rotation. Such tapers are often used for tone controls. Taper C is a left hand logarithmic curve which provides a small amount of resistance at the beginning of shaft rotation and a rapid increase at the end. This taper is most often applied as a volume (gain) control. Taper F, a right hand logarithmic, is the opposite of taper C. This taper is used for contrast controls in oscilloscopes and bias voltage adjustment.

The tolerance within which the resistance taper must conform to the nominal (ideal) taper is usually expressed only in terms of the resistance at 50% of full rotation. Military specifications require that the resistance taper *shall conform in general shape to the nominal curves* and that resistance value at 50% ( $\pm 3\%$ ) of rotation shall be within  $\pm 20\%$  (10% for cermet). For commercial controls this particular specification figure can be as high as  $\pm 40\%$  tolerance at 50% rotation.

**Hybrid elements.** It is possible to combine a wirewound element with a conductive plastic coating to realize certain benefits. The hybrid element will exhibit the temperature coefficient and resistance stability of the wirewound element and the long operational life, low resolution and low noise of the conductive plastic element. Contact resistance will be about the same as with conductive plastic.

Wirewound plus conductive plastic increases the cost of hybrid elements significantly because of the extra processing involved. In a similar manner, conductive plastic may also be applied over cermet with similar advantages. This hybrid element approaches the TC and stability of

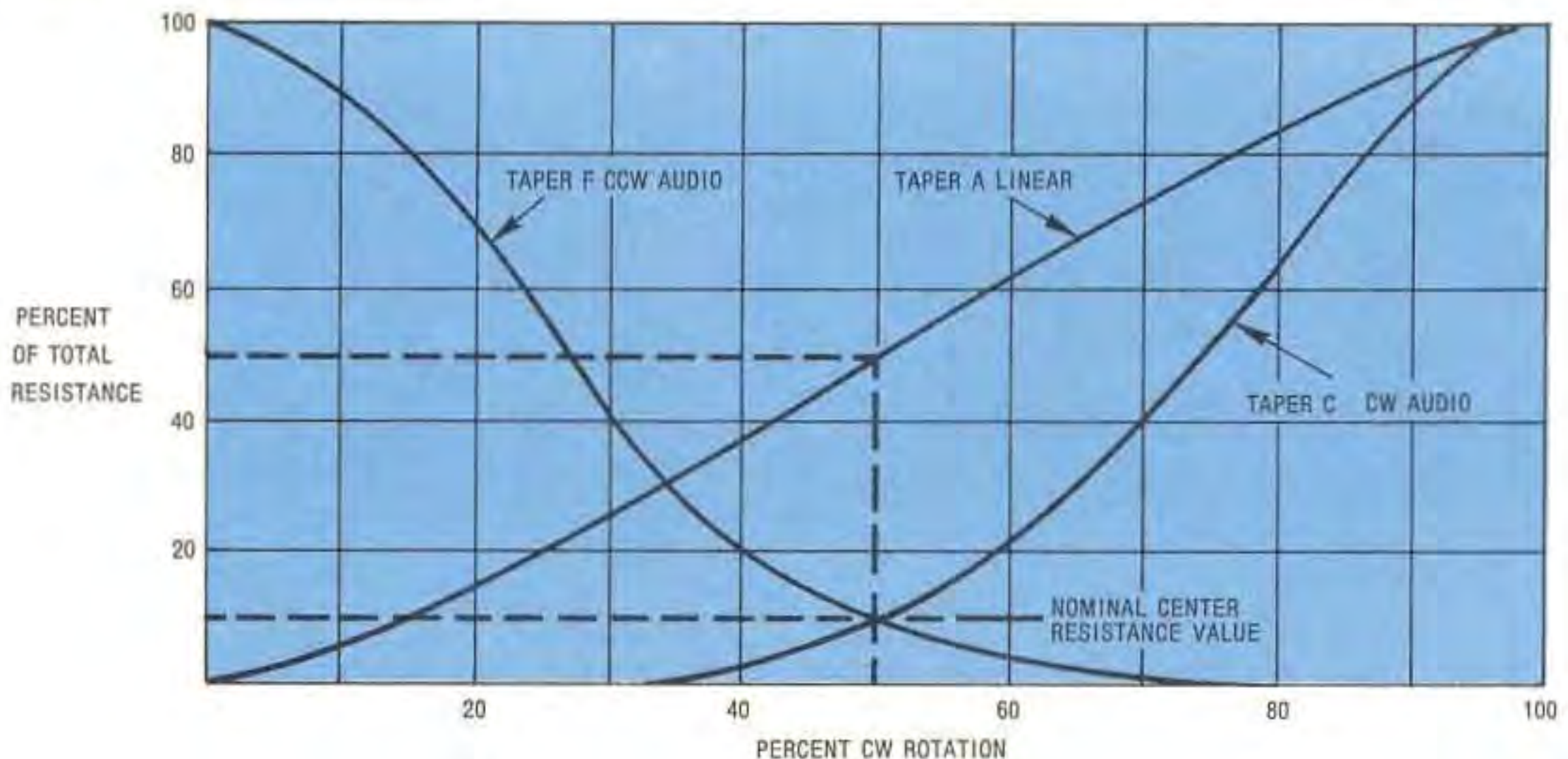

Fig. 7-12 Three resistance tapers taken from MIL-R-94B



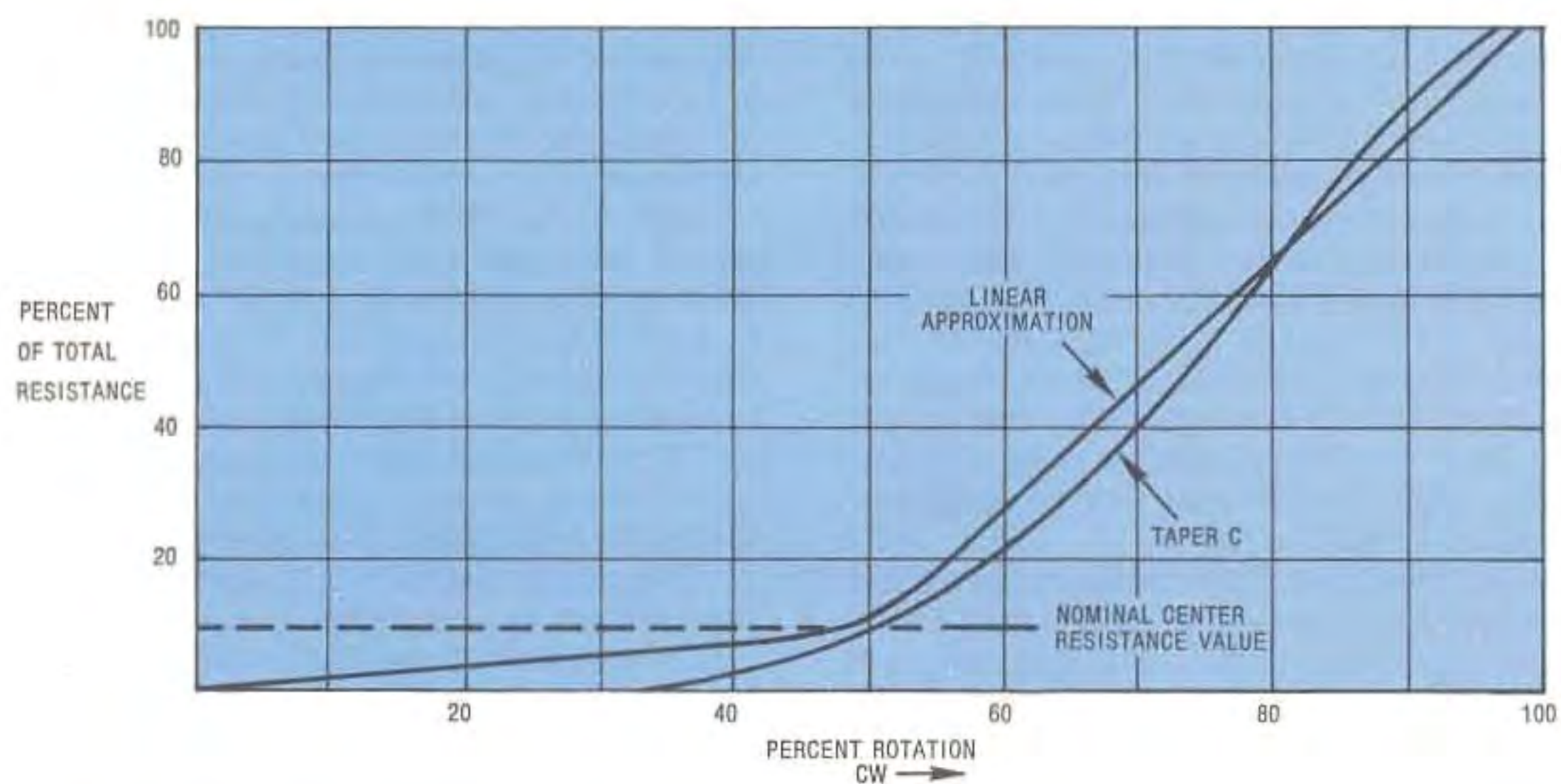

Fig. 7-13 A film element can be designed as a linear approximation to the ideal resistance taper

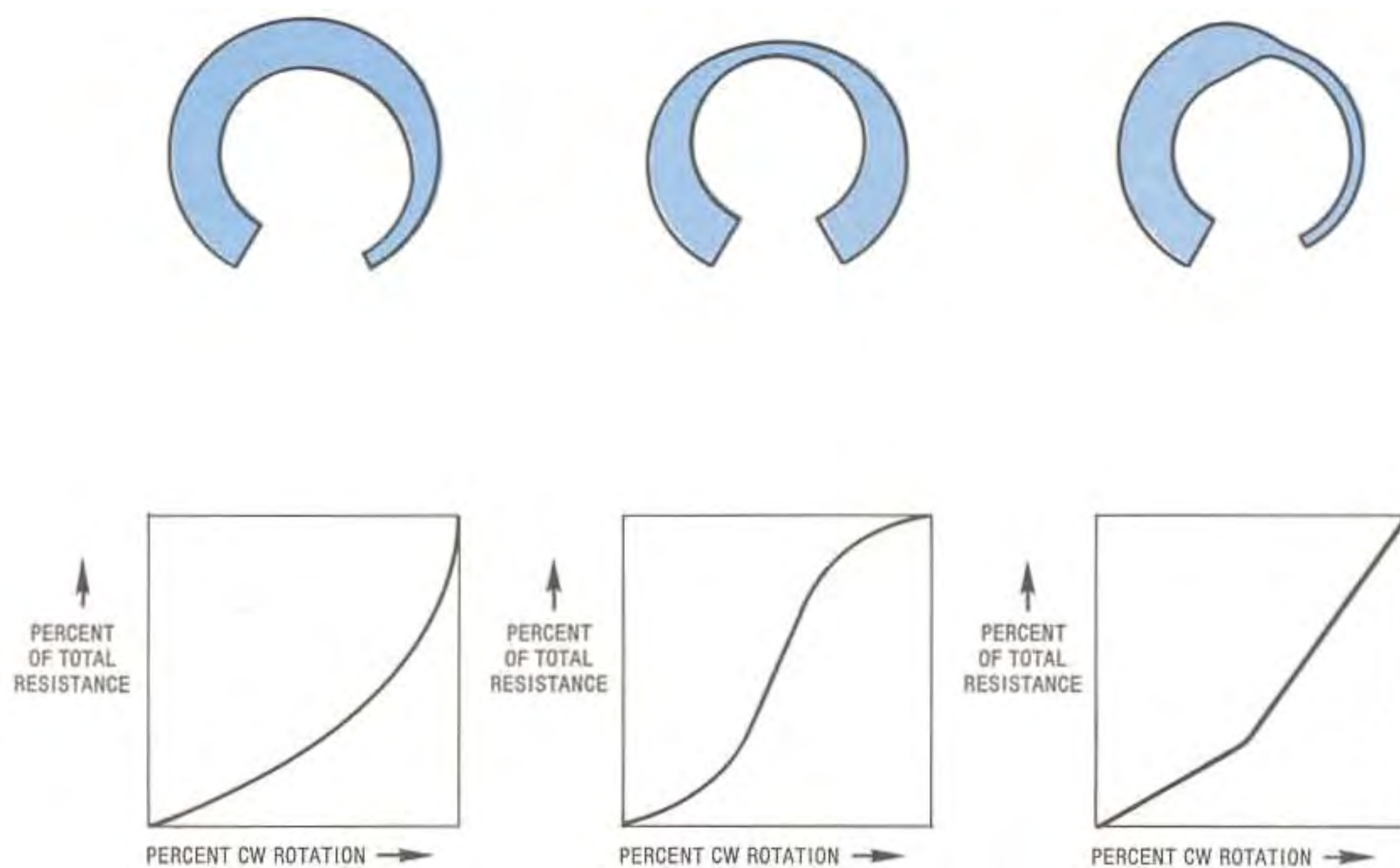

Fig. 7-14 Film element patterns and related graphs of resistance tapers



cermet.

**Selection factors.** The major application for wirewound-carbon elements is high-precision servo systems where the benefits in overall stability will justify substantially higher cost.

**Nonlinear nonwirewound elements.** The techniques used to create resistance tapers, described earlier, can be used to achieve a variety of nonlinear functions. A detailed presentation of the selection factors and applications for these devices is presented in Chapter 6. The following paragraphs explain the construction methods used to produce smooth nonlinear functions with conductive plastic elements.

The conductive plastic resistive track can be shaped to produce nonlinear functions. The slope of the output function is inversely proportional to the cross section of the resistive element. The minimum and maximum cross sections yield the highest and lowest resistivities respectively. This technique of cross section variation yields smooth output curves free from the scalloped output of tap and shunt techniques.

Sharp changes in the resistance element pattern do not produce corresponding sharp changes in the slope of the output function as is characteristic of the wirewound element. This differ-

ence is due to the distributed vs. lumped resistive characteristics of the conductive plastic and wirewound respectively. The conductive plastic behaves as an electric field with the current flow distributed throughout the element cross section.

The flow lines in Fig. 7-15A illustrate the limitations on rate of change of slope without current collectors. Notice that the current lines are unaffected by the cross hatch region labeled *ineffective*. The current lines and output curves for this case would not change if the cross hatch section were removed. An identical shape is laid out in Fig. 7-15B with a conductive current collector (conductive termination material) is added at one edge of the ineffective area. Addition of the current collector has shaped the current lines and hence the output curve. By varying the cross section area and the resistivity of the element materials, a wide variety of functions is possible. Fig. 7-16 shows three examples of nonlinear conductive plastic elements.

**Element Summary.** Fig. 7-17 is a comparison of several common element types. The values are intended only as a guide. Look carefully at each individual specification when deciding which device to use for a specific application. The table should aid in narrowing possible choices.

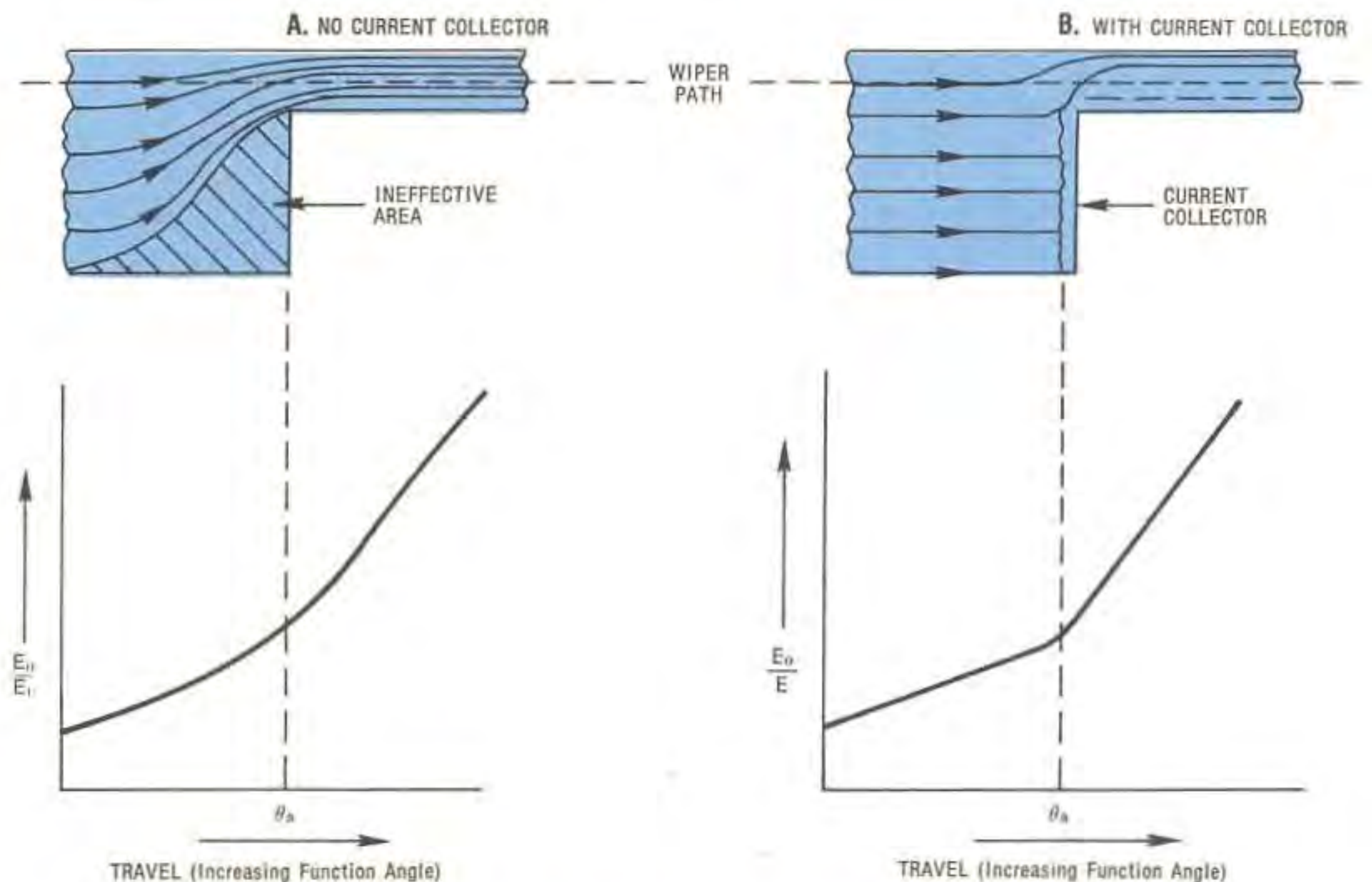

**Fig. 7-15** Adding current collector at sharp change in resistive element pattern causes distinct changes in the slope ratio.



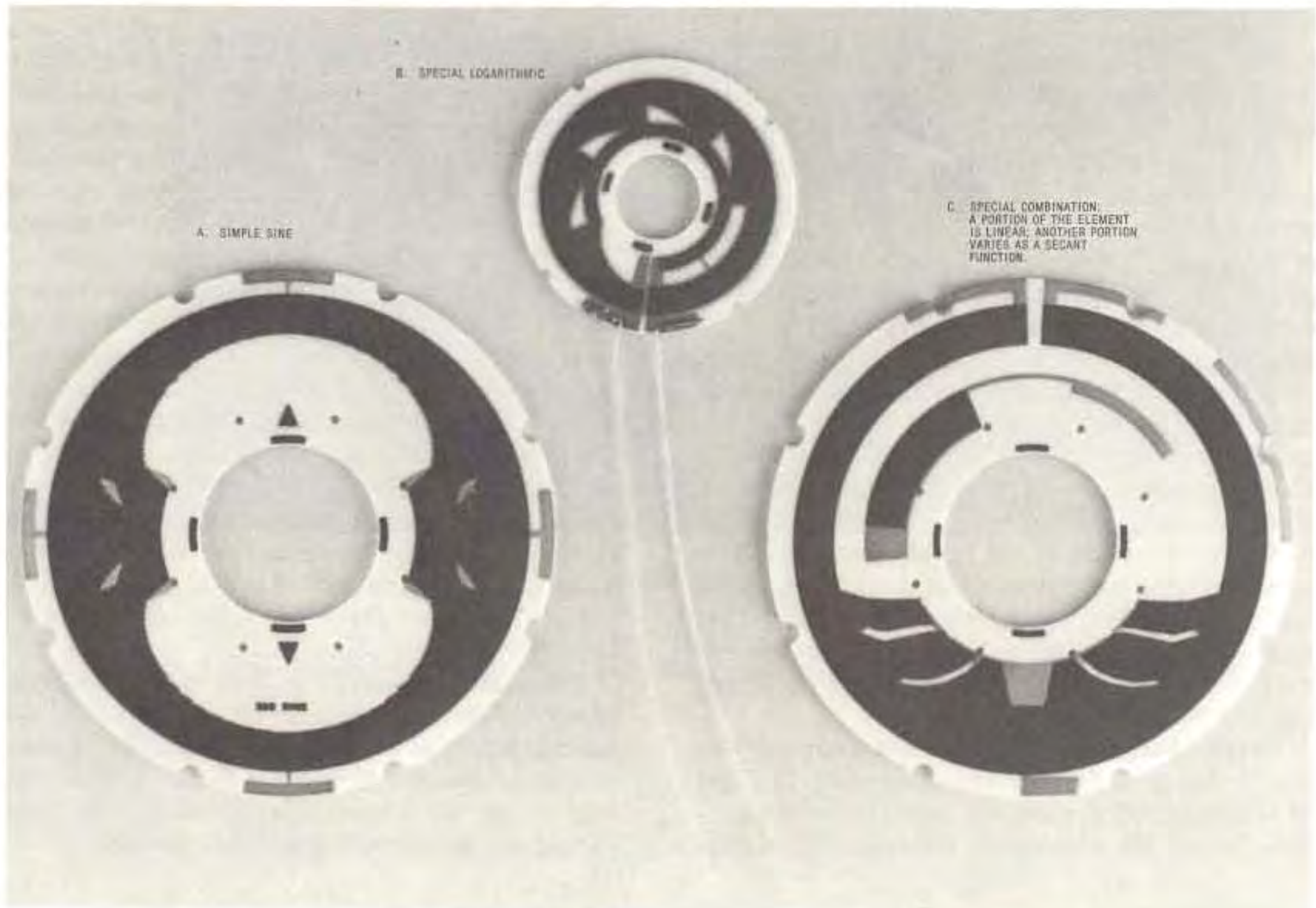

Fig. 7-16 Non-linear, conductive plastic elements

CHARACTERISTICS	WIREWOUND	CARBON		CERMET	METAL FILM	CONDUCTIVE PLASTIC
		MOLDED	DEPOSITED			
RESISTANCE RANGE	10Ω-100K	100Ω-10 MEG	100Ω-10 MEG	10Ω-5 MEG	50Ω-20K	100Ω-4 MEG
TEMP. COEFF.	±50 ppm/°C	±8000 ppm/°C	±1000 ppm/°C	±100 ppm/°C	±50 ppm/°C	< ±200 ppm/°C
RESOLUTION	0.1% to 1.0	—	—	< 0.05%	< 0.05%	< 0.05%
LINEARITY	0.1%	—	—	0.4%	0.2%	.05%
NOISE - STATIC	VERY LOW	HIGH	MODERATE	MODERATE	LOW	LOW
DYNAMIC	HIGH	MODERATE	MODERATE	MODERATE	LOW	LOW
ROTATIONAL LIFE	200,000 TO 1,000,000	5,000,000	1,000,000	500,000	100,000	4,000,000 REV.
FAILURE MODE	CATASTROPHIC	NOISY	NOISY	NOISY	RES. CHANGE OR CATASTROPHIC	NOISY
HIGH FREQUENCY PERFORMANCE	POOR	GOOD	GOOD	GOOD	EXCELLENT	GOOD

Fig. 7-17 Comparison of popular element types



## TERMINATIONS

Obviously, there must be some means of connection to the element and wiper that is accessible to the user. These connections, called *terminations*, take many forms depending on specific needs and applications.

There are two basic requirements for termination. The first is making connection to the element. The second is providing some form of external access terminal. Element terminations are dependent on the type of element. Therefore, they will be discussed individually for the major element types, wirewound and cermet.

The external terminals are designed to be compatible with the popular mounting and wiring techniques used throughout the electronics industry. Fig. 7-18 illustrates the common forms. The general requirement is that a good solid electrical connection can be made without damage or stress to the potentiometers' interior or exterior.

### Termination for Wirewound Potentiometers.

There are five common methods of terminating wirewound potentiometer elements:

- 1) single-wire (pigtail)
- 2) silver-braze
- 3) pressure clips
- 4) solder
- 5) single-wire tap

In the single-wire form a portion of the element is left unwound. This pigtail is then routed to a terminal providing external access. The pigtail is attached to the terminal by soldering, brazing or spot welding. The length of the wire is kept short to produce very low end resistance. This method requires a high degree of assembler skill and is vulnerable to shock and vibration. Care must be taken not to induce stresses when the connection is made to the external terminal.

A preferable method of reliable connection to the element is to braze a small metal tab to a few turns of the resistance element. The advantage of this method is increased reliability since redundant connection is made to the resistance element. An additional benefit is excellent ability to withstand severe shock and vibration. A wire is welded or soldered to the tab and the external terminal. Sometimes the external terminal is connected directly to the tab.

Because the element wire is not discretely terminated at one point the silver-braze method of termination causes a slight increase in end resistance. Fig. 7-19 illustrates the brazing operation.

Pressure clips rely on mechanical connection between the clip and the element wire. The clip makes contact with one or more turns of resistance wire. Pressure clips are a potential source

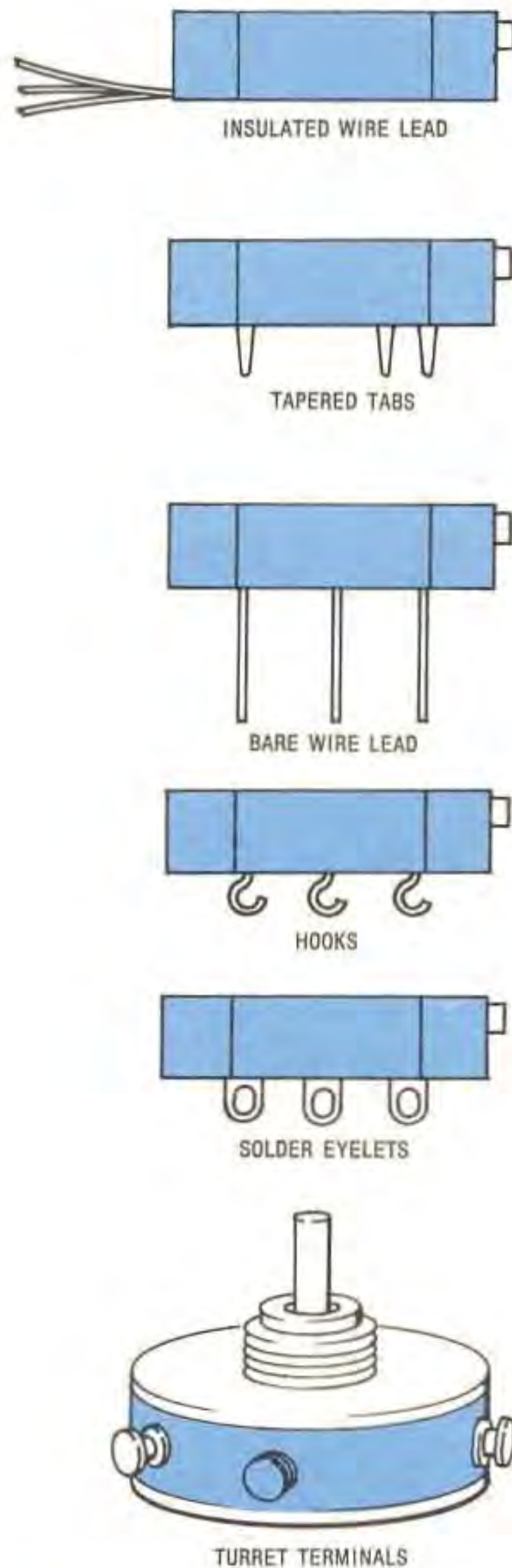

**Fig. 7-18** A variety of typical external terminations

of problems because contaminations, such as solder flux, can lodge between the clip and the element. In addition, it is possible for a clip to change position slightly during temperature excursions. This can result in a variation in the number of wires being contacted and could cause noise or sudden output variations. Because of these undesirable possibilities the pressure clip method of termination is becoming obsolete in the potentiometer industry. Some manufacturers



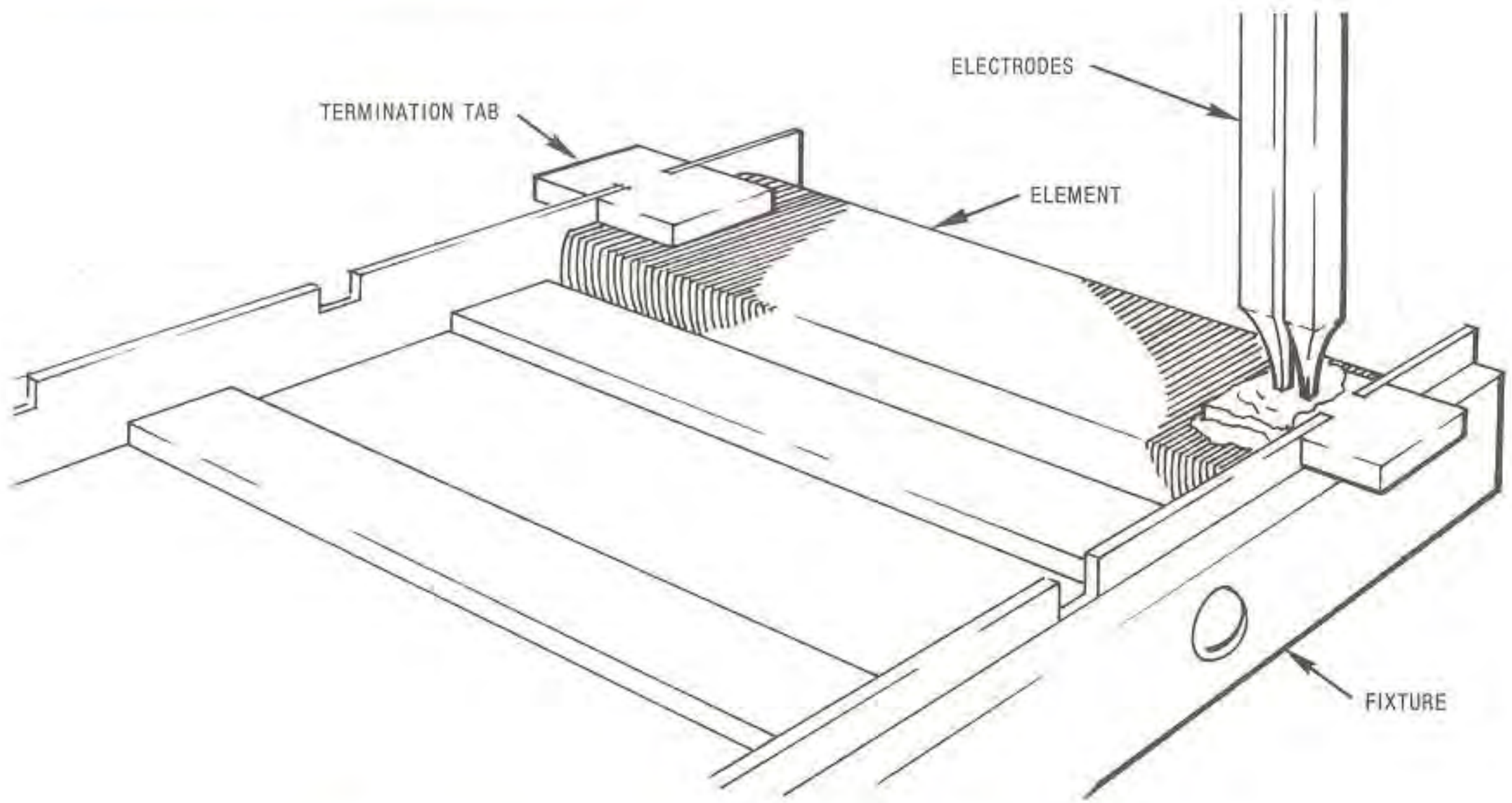

Fig. 7-19 Brazing operation for wirewound element termination

still use pressure clips in low cost potentiometers designed for non-critical applications.

A small wire may be soldered to the element to make connection to the external terminal. If properly accomplished with a high temperature solder a reliable connection will be made. Good assembly technique is necessary to insure that no stress is present at the element end of the wire.

Another single-wire technique which is commonly used to tap or connect to a single turn of resistance wire is one using percussion welding. This is primarily used to make precision non-linear elements by tapping and shunting as discussed earlier in this chapter. With this method a small diameter wire is connected to a percussion welder. The free end of the wire is positioned near a specific turn of resistance wire which has been selected by mechanical or electrical measurement. The end of the wire is placed on the target turn of resistance wire. A preset electrical charge is discharged through the junction of terminal wire and resistance wire resulting in a weld of the two molten surfaces that is as strong as the parent materials. Because fine wire and precise positioning is involved the operator usually works with a microscope. The opposite end of the termination wire is then attached to an external terminal.

Fig. 7-20 illustrates some popular element terminations used for wirewound potentiometers.

**Termination for Cermet Potentiometers.** Thick film conductive pads are used as a termination

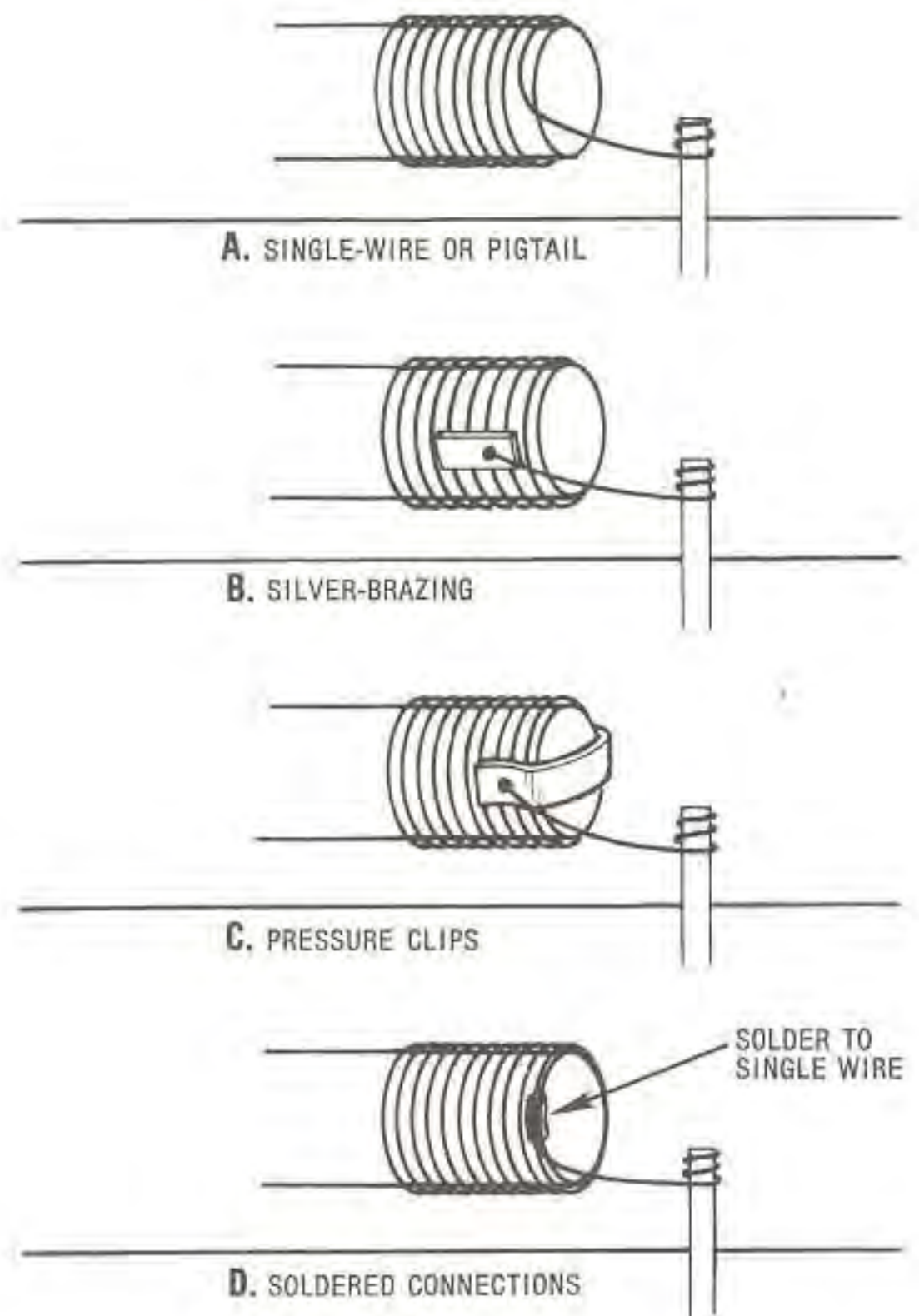
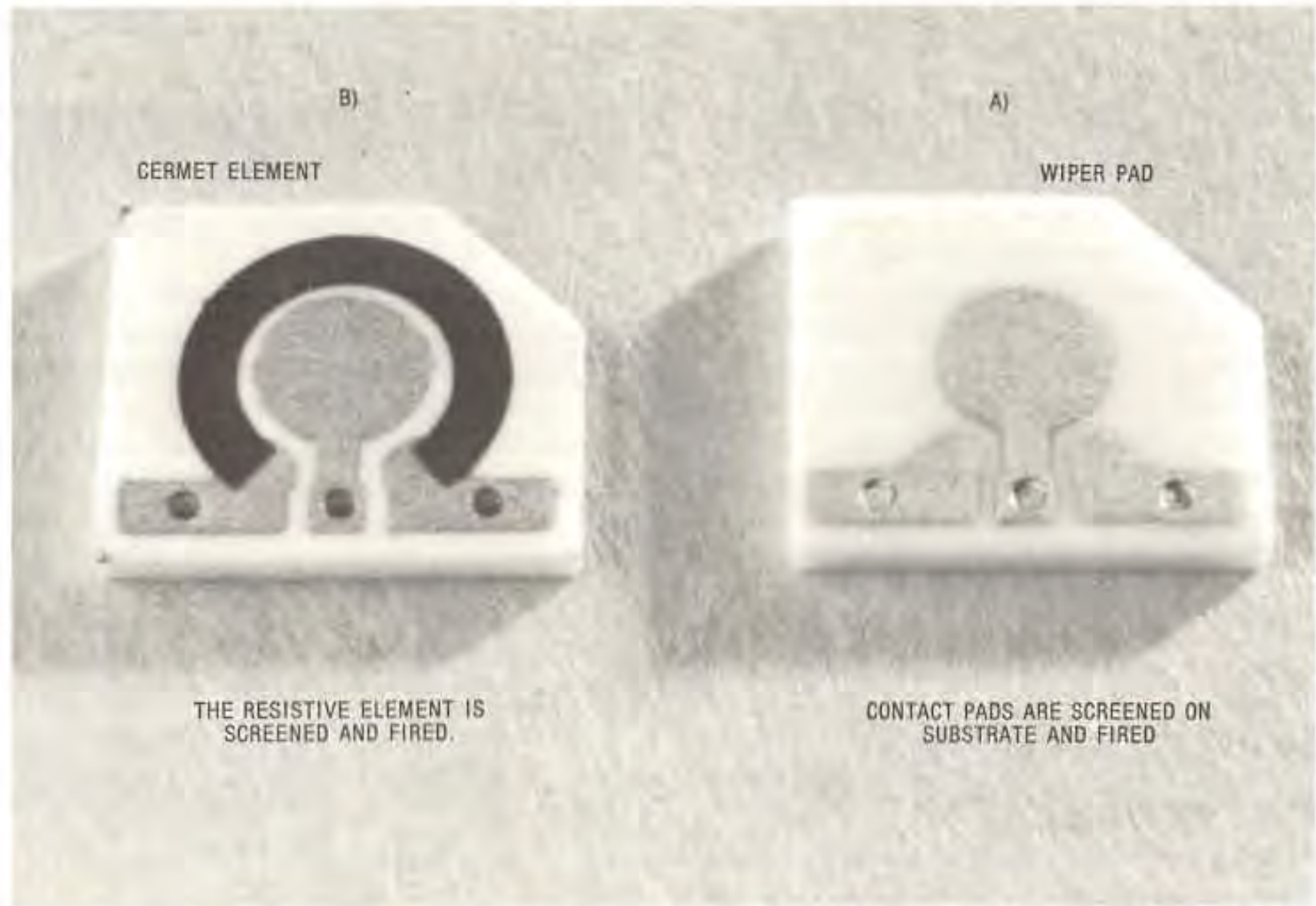

Fig. 7-20 Various methods of element termination for wirewound elements





**Fig. 7-21** Connection to the cermet element is made with conductive pads under the ends of the element

means for cermet elements. There are two methods of application.

The most common method is to silkscreen the pads on the ceramic substrate using a conductive precious metal paste, such as palladium-silver. The substrate is then fired at a temperature of  $950^{\circ}\text{C}$  to remove all the solvent and binder. The resistance element is screened on the substrate with the ends overlapping the previously applied termination pads and the assembly is processed through a kiln a second time to fire the cermet. The result is a solid electrical bond between the termination pads and the resistive element. Figure 7-21 illustrates the two stages of this construction technique.

A second method is to fire the resistance and termination materials at the same time. For this process either the resistance or termination ink is applied first and usually dried. Then the other material is screened to the substrate and the two are co-fired.

Choice of these methods depends on the manufacturer's economic considerations and mechanization capability. From a performance standpoint, the end product is essentially identical.

Access to the outside world is made through the use of terminals attached to the substrate and element termination in one of several ways. In one, a tinned terminal with flared head is placed

through a tapered hold with cermet termination material on its surface. The assembly is heated and the solder coating of the termination is reflowed around the terminal pin. See Fig. 7-22A. The tapered configuration of the pin creates a physical interlock to improve resistance to pin pull-out.

A less secure method of termination, from a pull strength standpoint, uses a plain straight pin which is soldered into place using wave soldering. This technique, illustrated in Fig. 7-22B, depends entirely on the solder for mechanical strength and electrical connection between the pin and the termination material printed on the substrate.

Another termination method, Fig. 7-22C, is to install terminals by swaging (mechanically heading) them in place under very high pressure with an upset section on each side of the substrate. This provides a solderless bond directly between the cermet element termination and tin plated copper pins or leads. Residual stresses existing in the swaged pin insure that intimate contact is maintained through thermal cycling.

In this process wire is inserted through holes in an alumina substrate. The wires are clamped and mechanically upset filling the volume of the hole and forming a head on both sides of the element. An electrical and mechanical bond results with intimate contact between the wire and the termi-



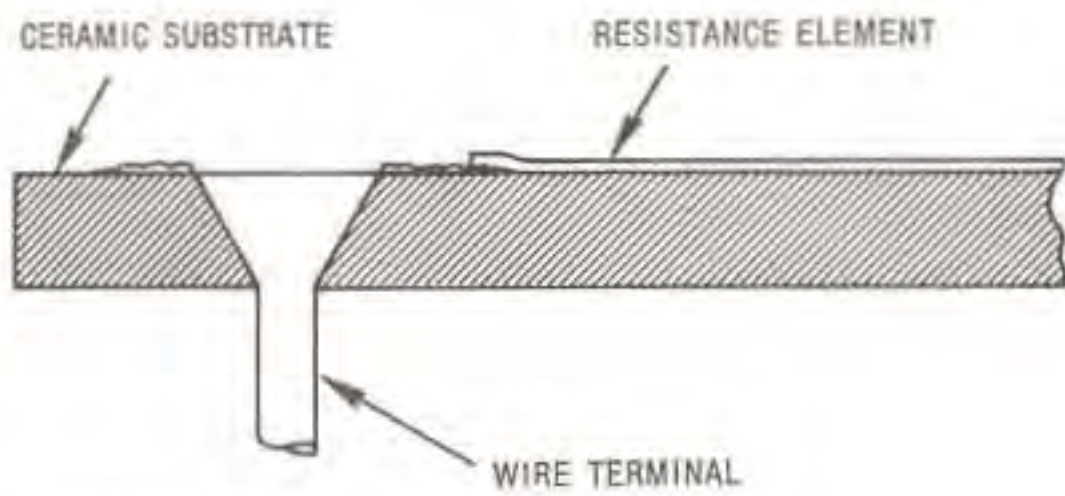

A. HEADED TERMINAL SOLDERED IN PLACE

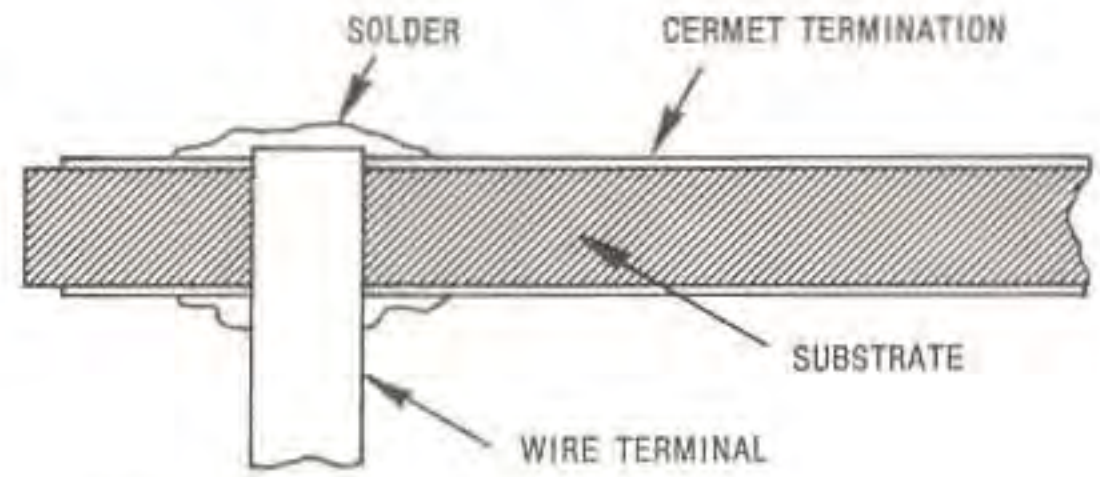

B. STRAIGHT TERMINAL SOLDERED IN PLACE

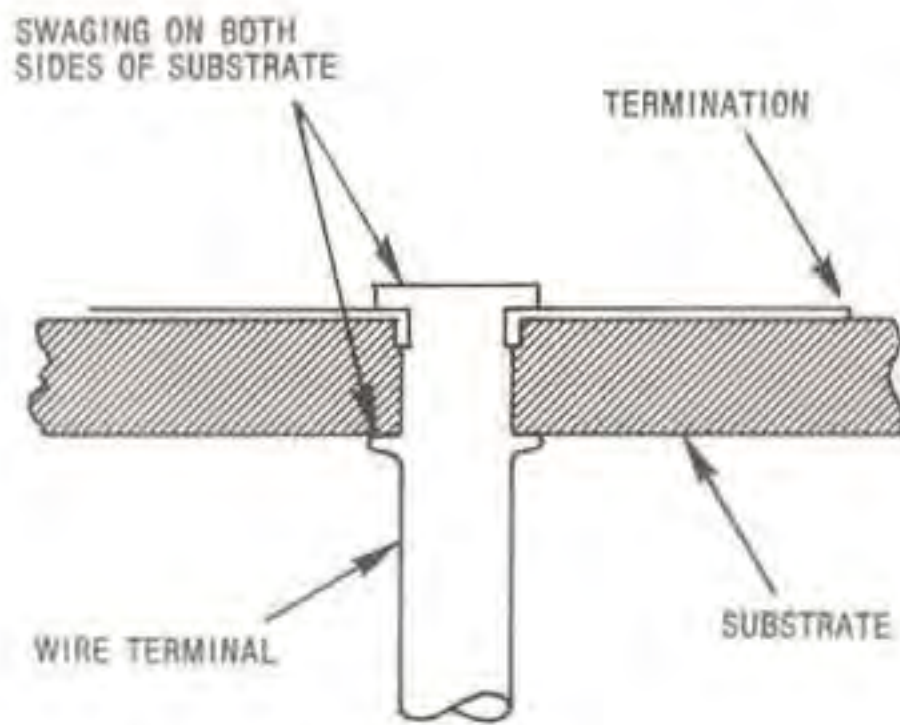

C. TERMINAL WITH SWAGING

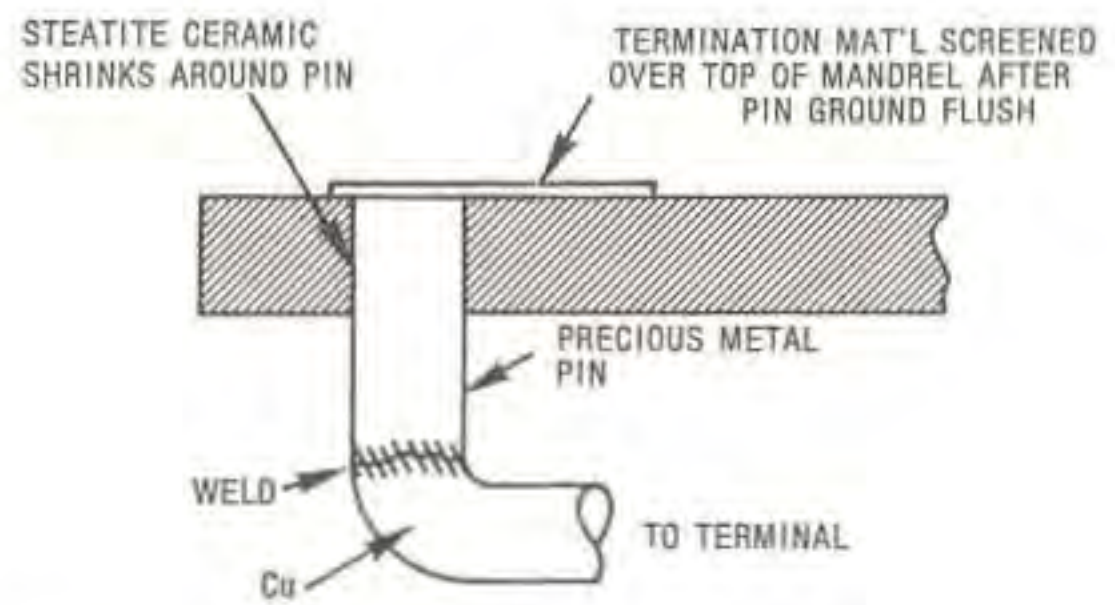

D. FIRED-IN PIN TERMINATION

nation material under the top head and along a portion of the shank because some cermet termination material is present in the holes.

Some cermet elements with steatite substrates have fired-in metal pins (usually precious metal to accommodate ceramic firing temperatures) as shown in Fig. 7-22D. These are installed and extend through and beyond the substrate before firing. When the assembly is fired the substrate shrinks tightly and holds the pins in place. They are then ground flush on one side and cermet termination material is printed over them. This results in connection between pin and element termination. To minimize the cost of the precious metal required, conventional copper leads are typically welded on to provide the external terminal.

Metal clip termination, Fig. 7-22E, eliminates the need for holes in the substrate but does require termination pads under the clips. After installation a solder reflow process is usually used to electrically and mechanically bond the clip to the cermet termination material.

**Terminations for Other Nonwirewound Elements.** Connection to other potentiometer ele-

MECHANICAL CLIPS

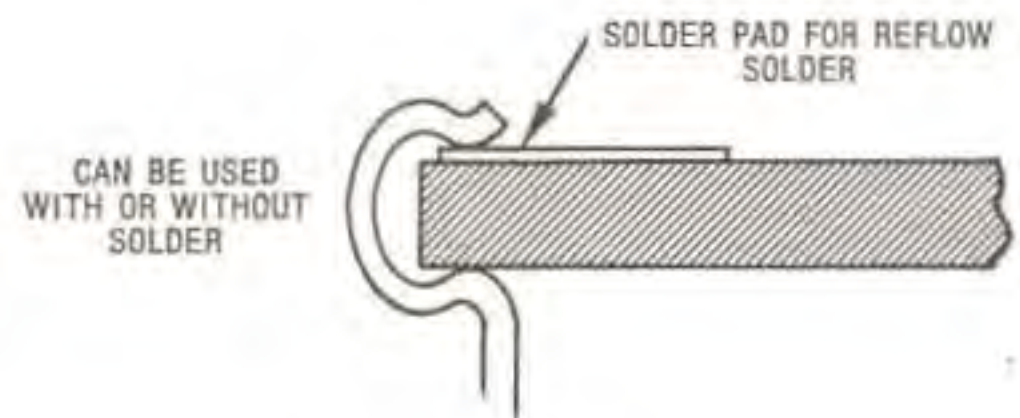

E. CLIP TERMINATION

Fig. 7-22 Terminations for Cermet Elements

ments generally use an underlying metal contact over which the element termination material is applied. The methods are completely analogous to those described for cermet. Another method, used very infrequently, involves conductive epoxy pastes to bridge between the element proper and the external access terminal.



## CONTACTS

The wiper has a significant effect on many potentiometer parameters. Contact resistance, CRV, resolution, noise, power rating, operational life, and stability (with shock and vibration) are all influenced by the design of the movable contact.

Before discussing the factors related to contacts used in specific potentiometer designs consider what happens when two electrical members come together or make contact. The drawing of Fig. 7-23 shows two conducting members making contact and physically exerting pressure against one another.

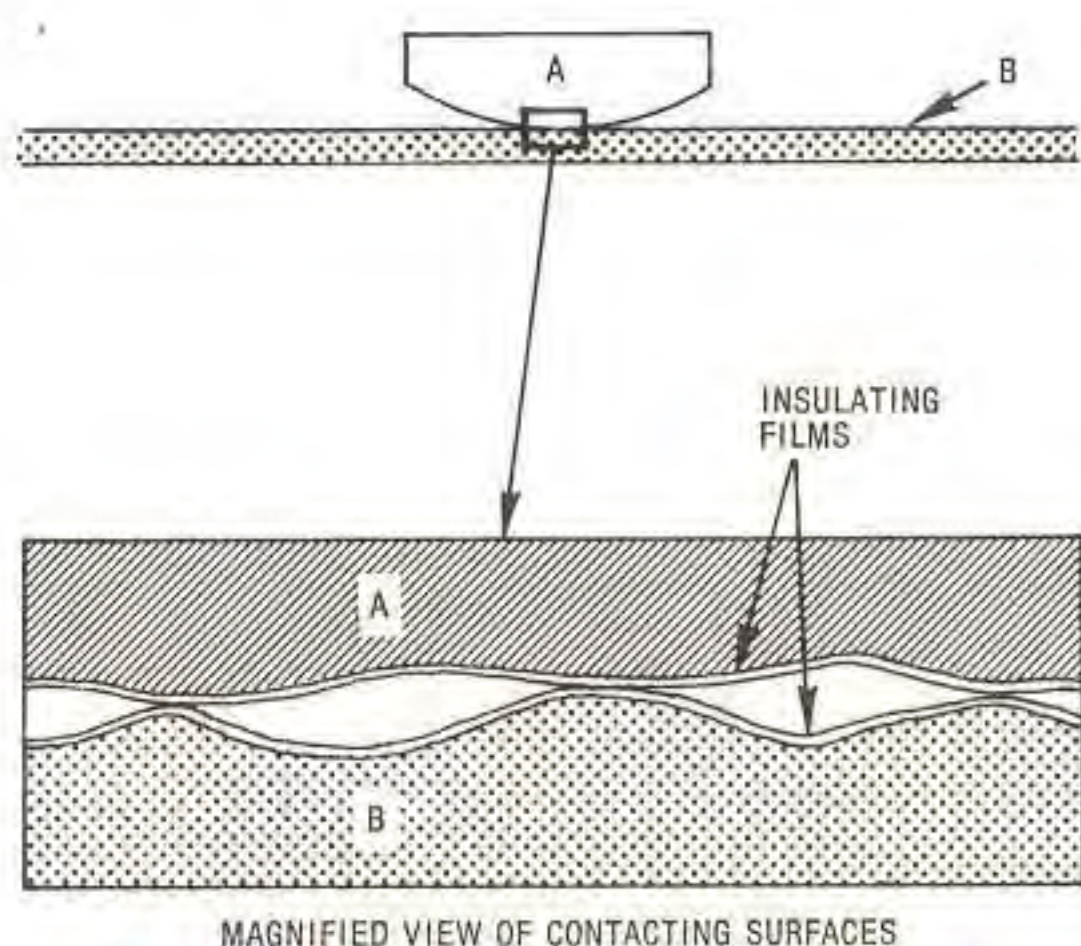

**Fig. 7-23** A simple contact between two conducting members A and B

Although the surfaces may look smooth, an extreme enlargement of the interface reveals a non-uniform contact. The members touch only where the high points of member A meet the high points of member B. The area where the two members are actually touching is only a fraction of the apparent contact area.

Another important factor is illustrated in Fig. 7-23. All metals have films of oxides, sulfides, absorbed gases, moisture, or organic molecules on their surfaces. Even if thoroughly cleaned, the films will quickly reappear. On base metals such as copper and aluminum, these films can form to thicknesses of 50 angstroms in a few minutes. They continue to grow until they are several hundred angstroms thick.

Films also form on precious metal contacts, such as gold and platinum, but are much thinner and cause few problems in making proper electrical connection. For this reason, many potentiometer contacts are made of some precious metal alloy.

Certain factors can improve the electrical contact between the two members of Fig. 7-23. Friction, generated by the sliding action, can abrade a portion of the insulating film and smooth the surface to increase the effective contact area. Increased pressure between the members will also improve contact, although too much pressure will greatly increase wear and hence shorten the operational life of a potentiometer.

Lubricants are commonly used on metal and cermet elements to prevent oxidation so noise (CRV) will be low. Mechanical life is also increased which is especially important for precisions. The lube reduces wiper and element wear and acts as a vehicle to contain minute wear particles during extended mechanical cycling. Potentiometers used in servo systems are required to respond faithfully during the first sweep of the element even after sitting dormant in one spot for long periods of time. A lube will help assure this type of performance.

There is no one magic lubricant that can be used in potentiometers that will meet all requirements. The anticipated operational environment dictates the type of lubricant. For example:

1. Low temperature.  
Normally a type of light silicone *oil* lubricant can be used.
2. High Temperature.  
Here a silicone type *grease* can be used. Low viscosity oils may tend to migrate away from wear areas at high temperature and may not be acceptable.
3. Outer space vacuum applications.  
Dry lubricants are generally used. Molybdenum disulfide or niobium diselenide are very effective in a high vacuum as in outer space.

Many potentiometer manufacturers have their own special proprietary lubricants. These generally consist of various silicone fluids and greases prepared to their exacting specifications.

Movable contacts are generally made from a metal alloy which provides its own spring force thus simplifying the mechanical design of the assembly. In addition to aiding electrical conduction by helping to break down insulating films, spring pressure also aids in maintaining continuity during shock and vibration.

The physical form of the wiper takes many shapes as indicated in Fig. 7-24. The contact generally used with wirewound resistance elements is a single-fingered wiper similar to A in Fig. 7-24. It is formed in a manner that insures it will make physical contact with more than one turn of resistance wire. The contact material used is hard enough to minimize contact wear without having an abrasive quality which would shorten element life.





Fig. 7-24 Moveable contacts come in many different forms

The contact labeled B in Fig. 7-24 is typical of those used with nonwirewound elements. They are usually multi-fingered in order to decrease contact resistance; hence, the contact resistance variation, CRV. A careful study of Figures 7-25 through 7-28 will show why this is true.

In Fig. 7-25, 10 volts is applied across a resistive element. Equipotential lines are indi-

cated by broken lines. Notice that they are all straight and equally spaced. Six different contact points, A through F, are indicated along one of the equipotential lines. If a very high resistance voltmeter were used to measure the contact voltage with respect to end terminal 1, each point would read 4 volts. This would seem to indicate that a single contact placed anywhere along the width of the element would yield a 4 volt poten-

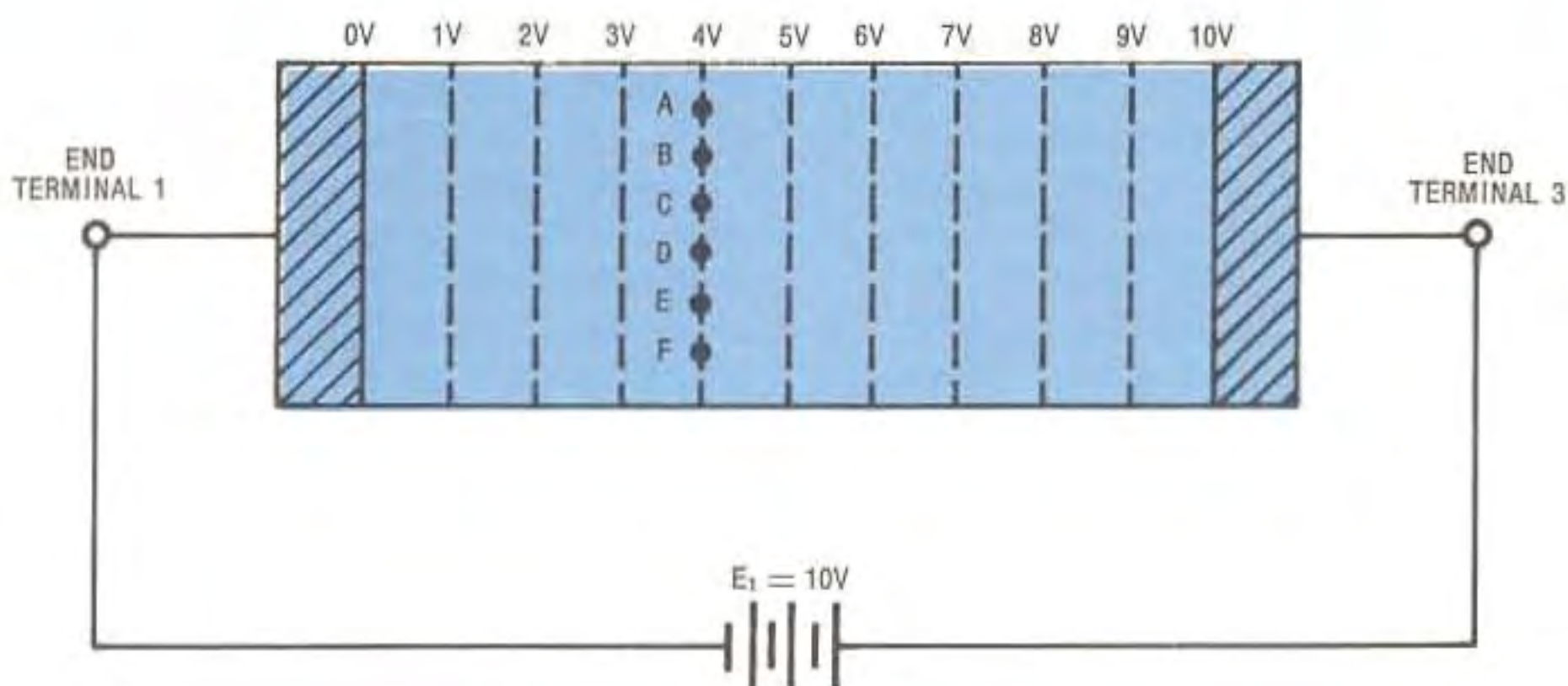

Fig. 7-25 Simple element showing equipotential lines



tial. If the wiper current is zero (i.e., an unloaded voltage divider) this is, in fact, true.

Look at what happens in Fig. 7-26 when the potentiometer is connected in a manner similar to the CRV and ENR demonstration circuits of Chapter 2. The equipotential lines start out fairly straight and evenly spaced at end terminal 1 but become much closer together and distorted in the vicinity of the single contact.

Consider the analogy of many people exiting a large theater with multiple aisles, only to find that all must pass through a single door in the lobby. The result is a crowding of the people. A similar effect happens with the electrons making up the current flow of the loaded voltage divider in Fig. 7-26. The result is current crowding around the contact.

Now look at what happens in Fig. 7-27 with the single contact placed along the edge of the element. The crowding effect is even worse than before. Any current, as in the case of a current rheostat or loaded voltage divider, passing through the very top of the element must not only make its way from left to right, but also must pass through more resistance material to get down to the contact. The end result is a higher contact resistance as evidenced by the higher meter reading in Fig. 7-27.

It is apparent that additional contacts would improve the situation. If multiple contacts are placed close together, however, current crowding will still result. If the theater in the analogy described above were redesigned by adding doors placed close together at one point in the

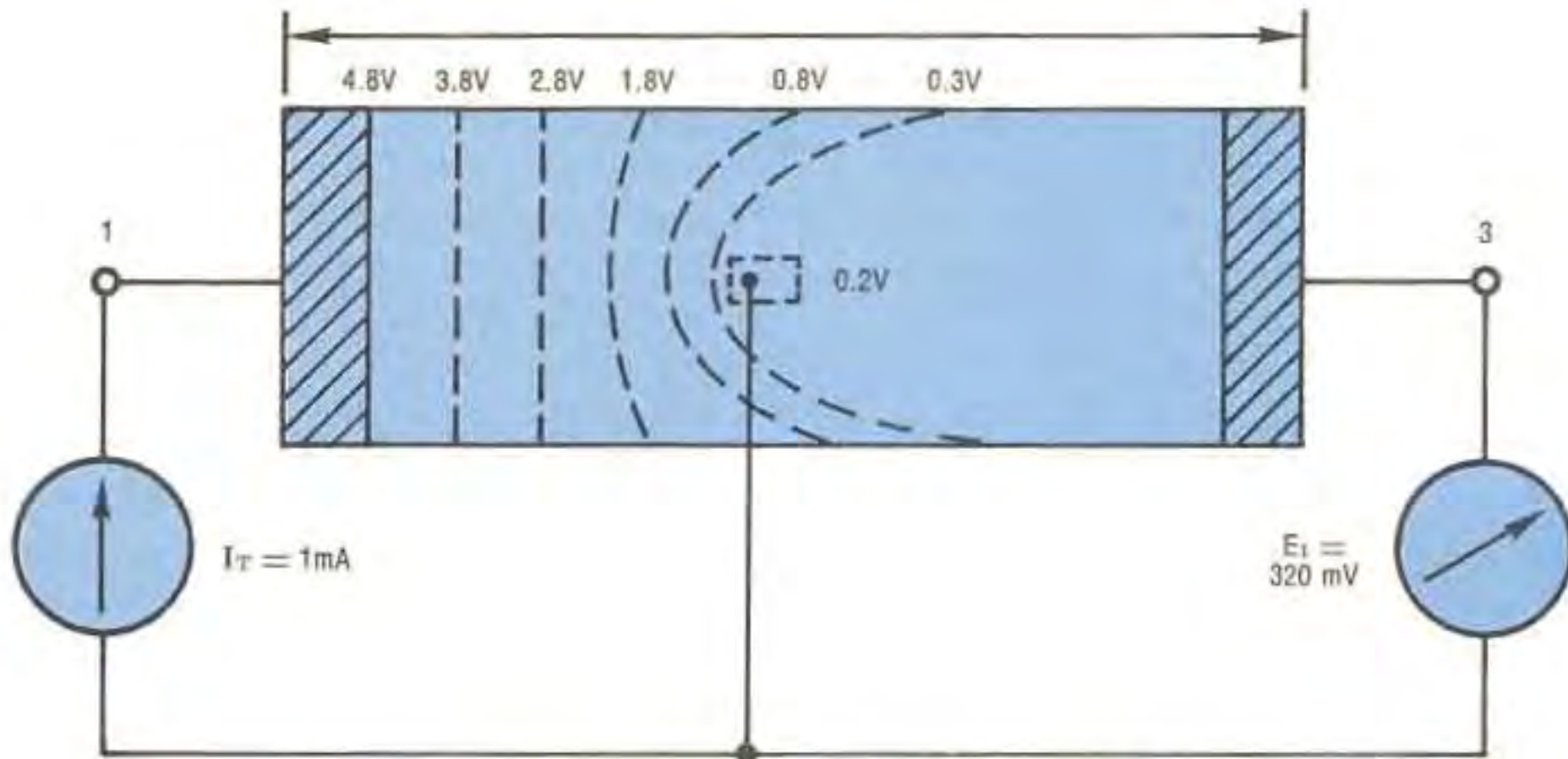

Fig. 7-26 Illustration of current crowding in single contact

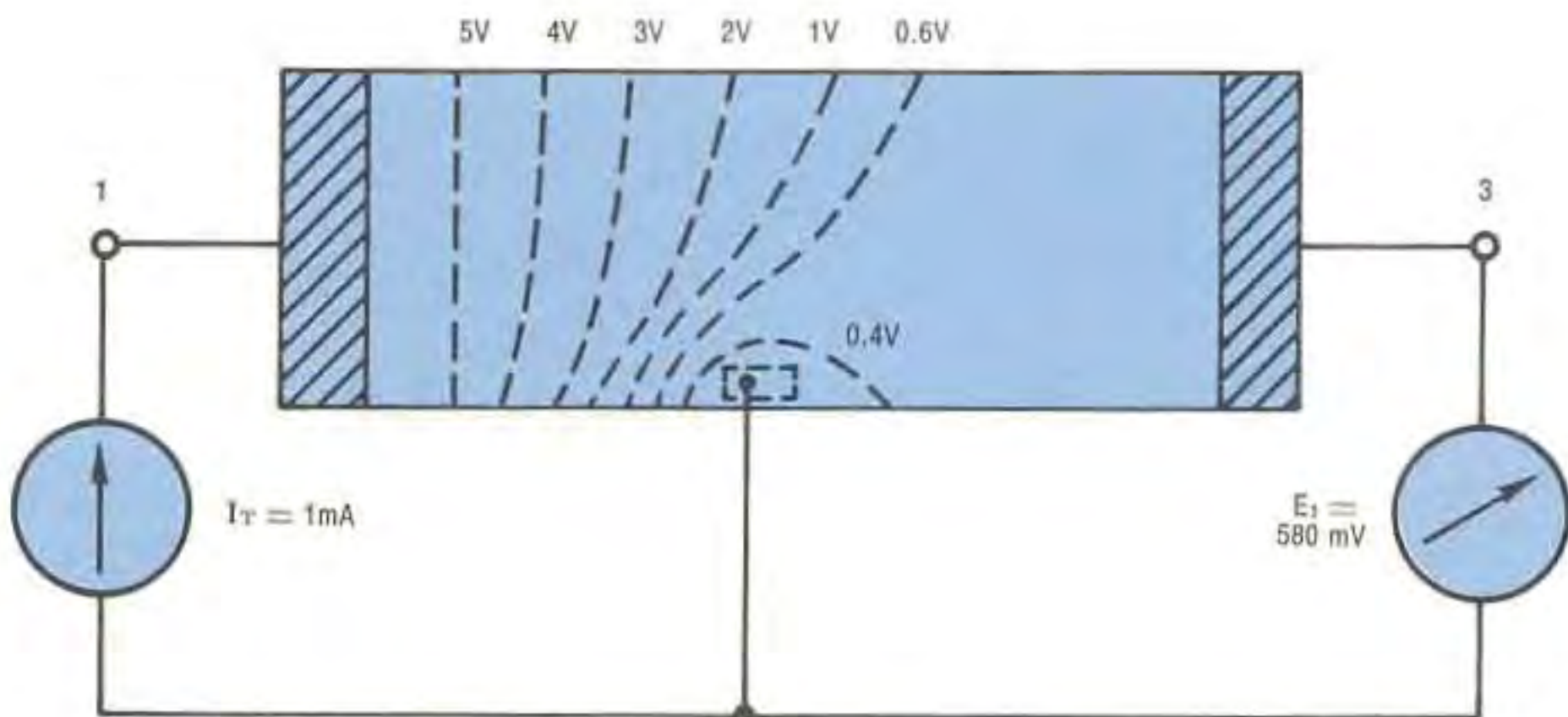

Fig. 7-27 A single-contact placed on edge causes increased contact resistance



lobby, crowding would be decreased. A better solution would be to separate the doors in an equidistant manner across the entire theater. The same is true for the contacts on the element of a potentiometer.

Fig. 7-28 illustrates the effect of placing five contacts, spaced equidistant, across the element. There is negligible current crowding and distortion in the equipotential lines. This results in the very low voltage at end terminal 3 which indicates a very low contact resistance.

The multi-wire wiper is an improvement over the sheet metal multi-finger wiper. In fact, the multi-wire wiper may be the single most important innovation in the past decade for nonwirewound potentiometers. It has greatly improved CRV performance and increased current carrying capacity of the wiper. The latter is of prime importance in current rheostats and loaded voltage dividers.

The effect of multiple contact wipers on CRV follows the same improvement pattern as for simple contact resistance. The worst possible case for CRV would be for a contact finger to lift completely, although this would rarely happen except possibly in cases of excess vibration or mechanical shock. It does aid in studying the effects of multiple contacts on CRV if complete loss of contact is assumed possible for a given finger.

When there is only one contact to begin with, the effect of losing a contact is disastrous. Even with two contact fingers, if any appreciable current is flowing through the wiper, the interruption of either will produce a substantial change in contact resistance with a corresponding change in output voltage. As the total number of contact fingers is increased, the effect of losing one of them becomes less significant.

In summary, both contact resistance and CRV are improved by using multiple-fingered wipers.

The optimum position of a single contact wiper is in the center of the width of the element. Multiple contacts should be distributed equidistantly across the width of the element.

One of the reasons nonwirewound potentiometers often outperform wirewound units under extreme shock or vibration is that multiple-fingered wipers are used with the quality nonwirewound units.

## ACTUATORS

Many different variations of the mechanical means which moves the wiper across the resistive element are possible. The following paragraphs explain some of the common actuator types.

**Rotary Shaft and Wiper.** One of the most common configurations designed for frequent manual adjustments uses a shaft with a knob on one end and the wiper on the other end. This arrangement, less the knob, is also used when the potentiometer is in a servo system and driven by a motor, gear train, or any mechanical means.

In the simplest form, the shaft is passed through a friction or snap-in bushing (used for mechanical mounting purposes) and extended far enough to permit attachment of a knob. An arm is attached to the opposite end to transmit the rotary motion of the shaft to the wiper.

Generally, the wiper must be insulated from the shaft. Some reliable means must be provided to permit external electrical connection to the wiper. Where continuous rotation is not required, it is possible to use a length of very flexible wire to connect the wiper to an external terminal. This has some very severe limitations relative to the mechanical operating life of the potentiometer.

Another more reliable approach to making connection from the wiper to an external access terminal is by means of an additional sliding con-

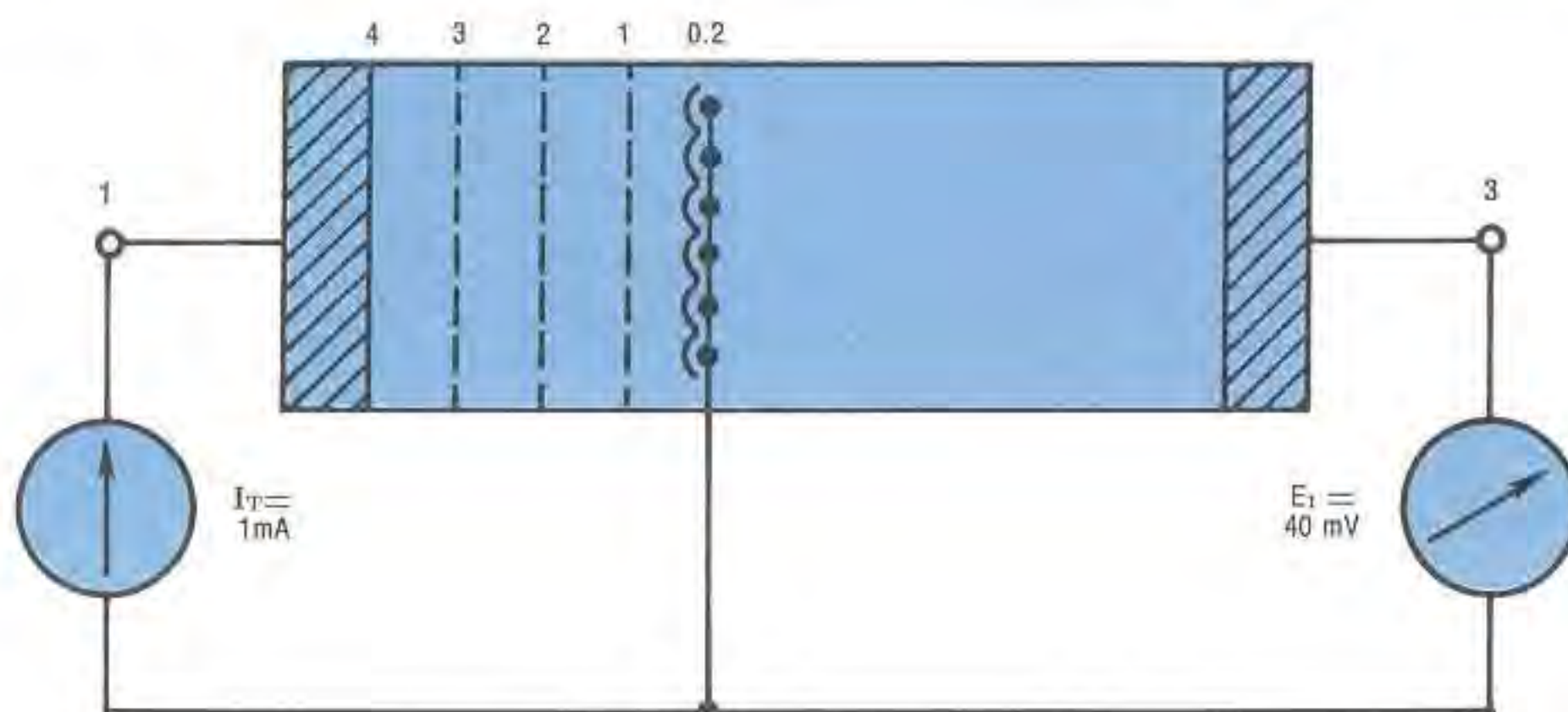

Fig. 7-28 Multiple contacts distribute current flow and lower contact resistance



tact. This sliding contact rides on a metal surface which is electrically connected to an external terminal. Some of the same considerations which applied to the element wiper will apply to this additional contact. The major difference is that both members may be of precious metal alloy and thus result in good contact with negligible contact resistance and contributed noise.

Fig. 7-29 illustrates several typical rotary shaft actuators. Careful design of the entire wiper assembly is necessary to yield proper performance with a reasonable manufacturing cost.

Many potentiometers are designed for a shaft rotation of less than one complete turn. This means that some form of mechanical stop must be used to limit the travel of the wiper to the element surface. For those cases where continuous rotation is required, the area between the ends of the element must be minimized but never shorted together. A smooth surface in this region is required for good performance as the wiper passes across it.

Rotary shaft actuators are also used in multi-turn precision potentiometers, such as those

shown in Fig. 7-30. The mechanical problems are increased since the wiper must move along the length of the element as well as in a rotational manner to track on the helixed element path. Some mechanical means, a solid *stop*, must be used to prevent excessive rotation.

One of the general mechanical requirements for precision units is that the wiper assembly precisely follow the motion (mechanical input) of the actuator (shaft) system. This assures that each incremental motion applied to the external end of the shaft is faithfully transmitted into wiper travel.

**Leadscrew Actuators.** The mechanical drive requirements of adjustment potentiometers are quite different from those of frequently adjusted controls or precision devices. A reliable means of adjusting the position of the wiper is needed and some mechanical improvement in the ability of setting the wiper at exactly the right spot is necessary. Once adjusted, the position of the wiper should not change due to normal shock or vibration until manual adjustment is again desired. This is best done with a threaded shaft or



Fig.7-29 Several typical rotary shaft actuators



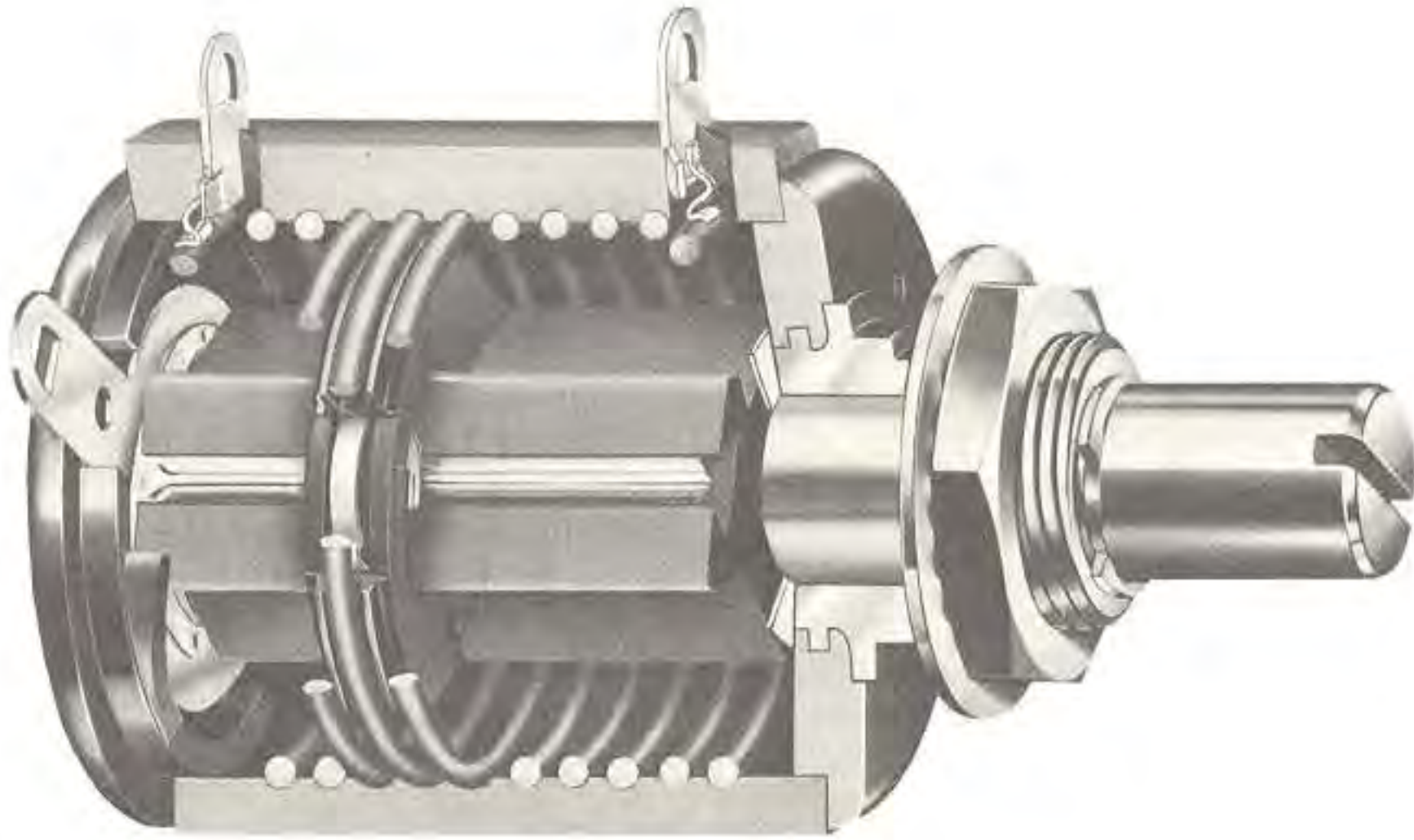

**Fig. 7-30** Interior of multiturn potentiometers illustrate the mechanical detail necessary for reliable performance

leadscrew.

Fig. 7-31 illustrates a typical leadscrew actuated (rectangular) potentiometer. A simple thread along the body of the adjustment shaft engages grooves in the carriage that holds the wiper. This mechanism provides the translation from turns of input rotation to the required linear wiper travel along the straight element.

Notice the arrangement of Fig. 7-31. A shaft

seal retainer serves to prevent axial movement of the shaft and the entrance of moisture. This also keeps the leadscrew from turning during vibration or shock.

Most quality leadscrew potentiometers incorporate an automatic clutching action at the end of the travel. This prevents damage to the assembly due to overtravel. In some configurations, continued rotation of the screw causes a ratchet

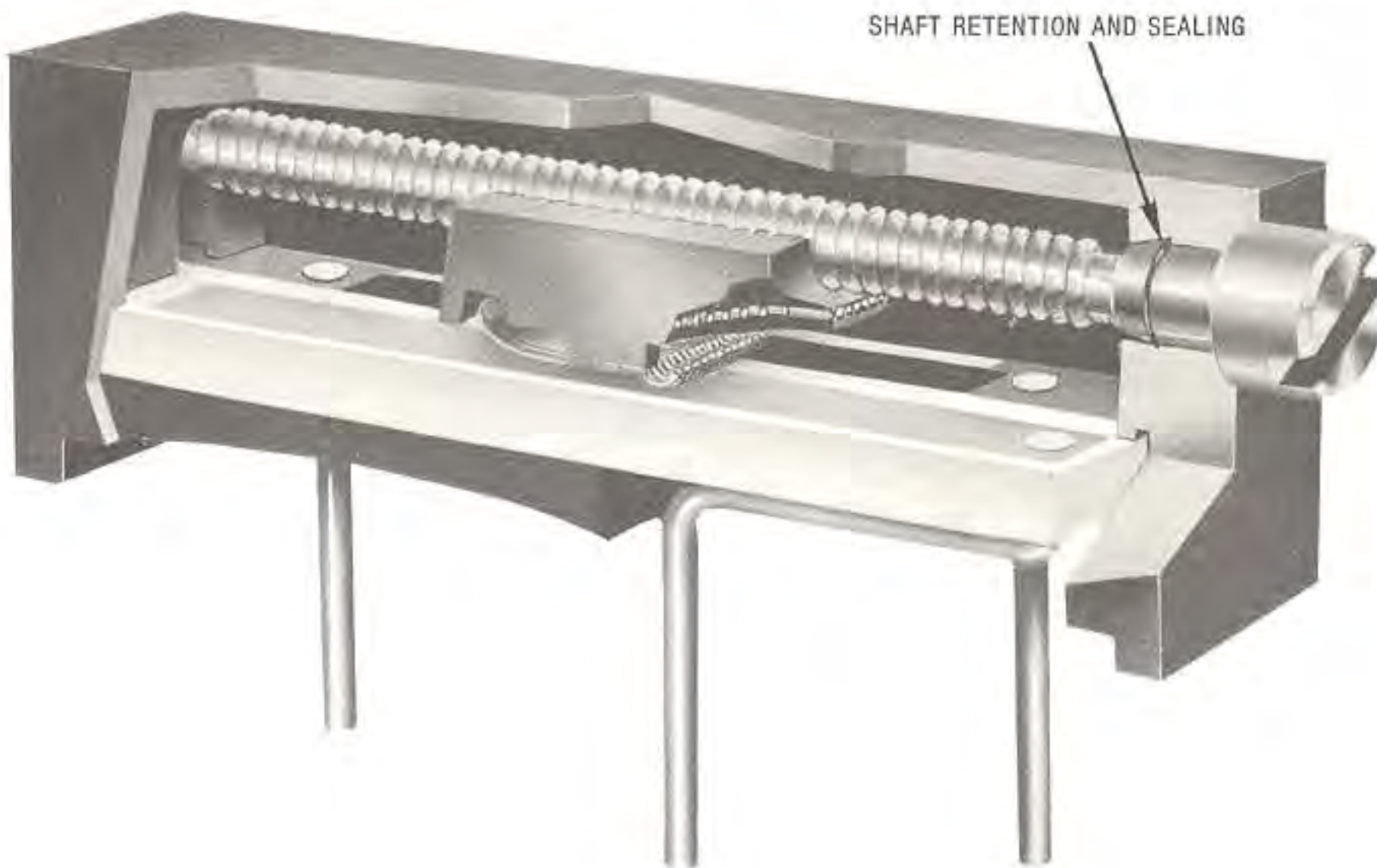

**Fig. 7-31** The interior of a lead-screw actuated potentiometer illustrates that many turns of rotational motion are required to cause the wiper to traverse the entire element



action with a convenient audible click to tell the operator that the end of travel has been reached.

**Wormgear Actuators.** A greater length of resistance element can be included in a given linear dimension if the element is formed in a circular manner. This requires a different means of actuating the wiper. Fig. 7-32 shows a typical design for a worm gear actuated (square) potentiometer. The adjustment screw worm engages the teeth of a small plastic gear which is about the same diameter as the element.

The wiper assembly is placed between the plastic gear and the element, making contact to both. When the gear is rotated by turning the adjustment screw, the wiper moves along the element. At the end of the element, the wiper assembly encounters a mechanical stop to prevent further movement. Should the operator continue to turn the adjusting screw, the gear will turn and slide against the wiper in a clutch-like action without further motion or any

damage. If the direction of the adjustment screw rotation is reversed, the wiper correspondingly begins to move immediately.

**Single Turn-Direct Drive.** Another variation is somewhat like the basic wormgear design, but without the gear and worm. A simple rotor with a slot, and usually mechanical stops, permits rotary adjustment of the wiper position in a single turn unit. A typical example is shown in Fig. 7-33A. In this design, an o-ring seal prevents moisture entrance and also provides friction which serves as a mechanical restraint to prevent unwanted wiper movement. The design of Fig. 7-33B is a lower cost unit that does not provide the sealing feature.

**Linear Actuators.** For some servo applications, it is desirable to tie the wiper assembly directly to an external rod so that a linear motion causes a direct linear travel of the wiper. A typical example of this type of unit is shown in Fig. 7-34.

Some linear actuated potentiometers, used as

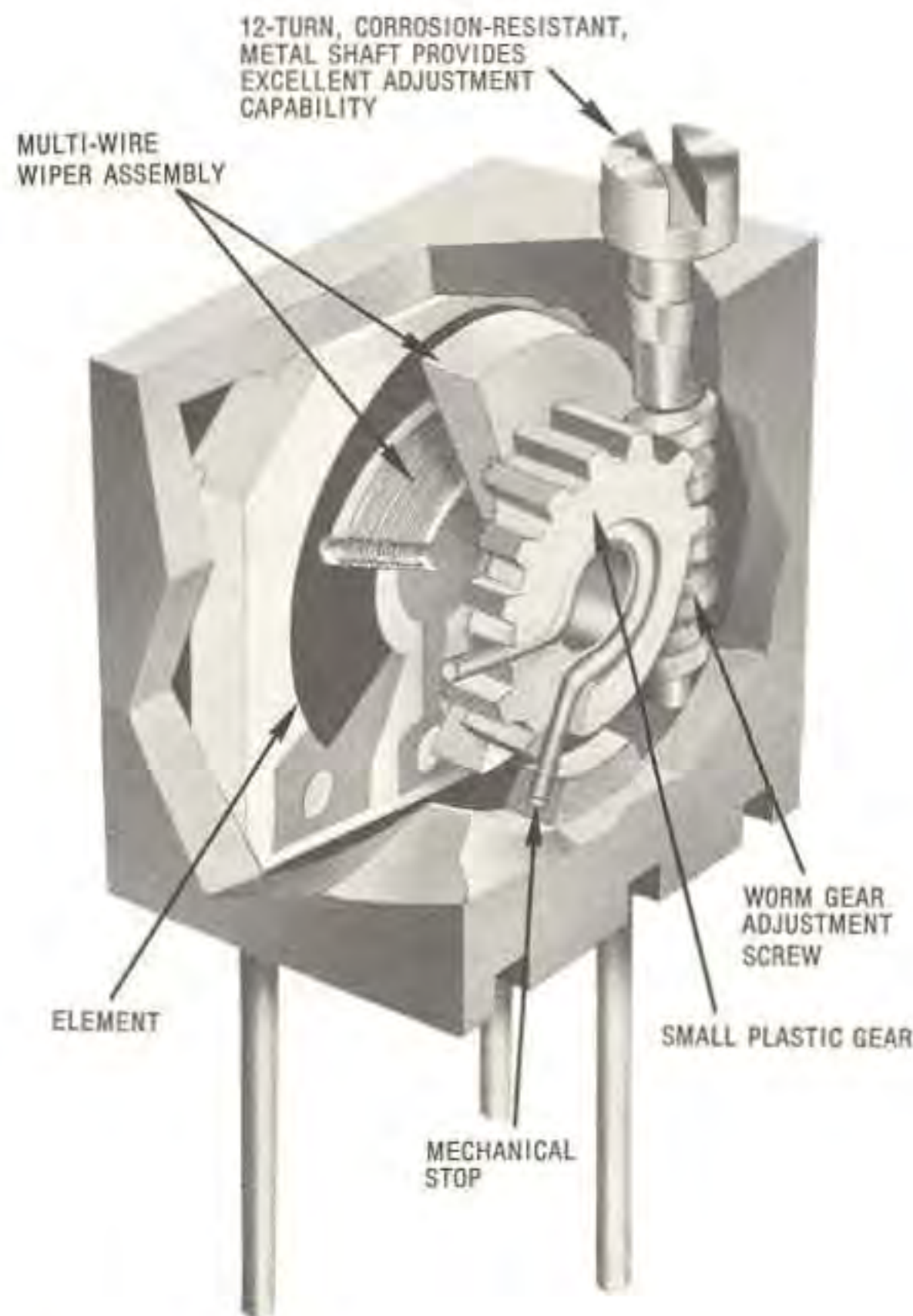

**Fig. 7-32** A typical worm-gear actuated potentiometer



A. SEALED CONSTRUCTION

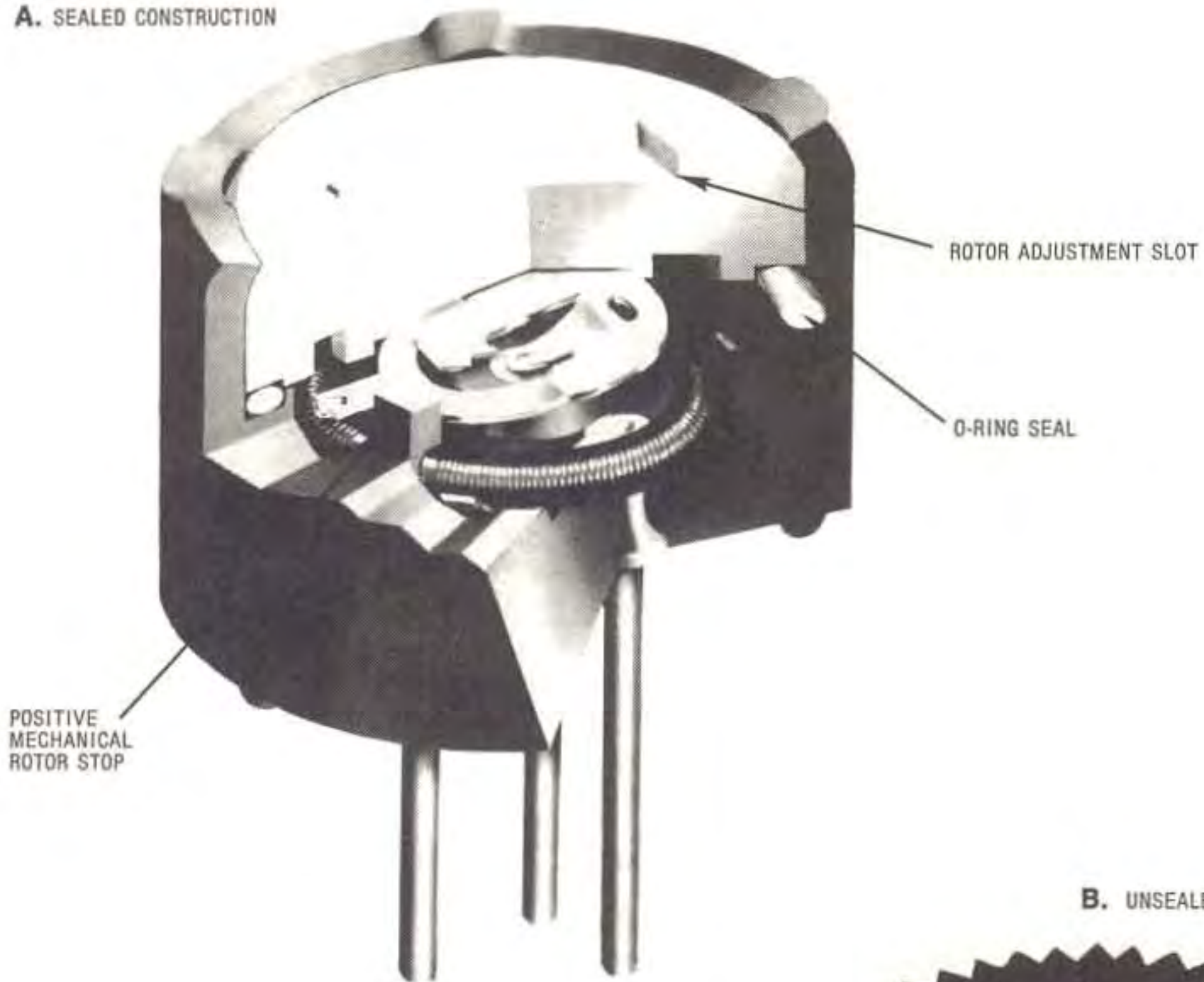

B. UNSEALED (OPEN) CONSTRUCTION

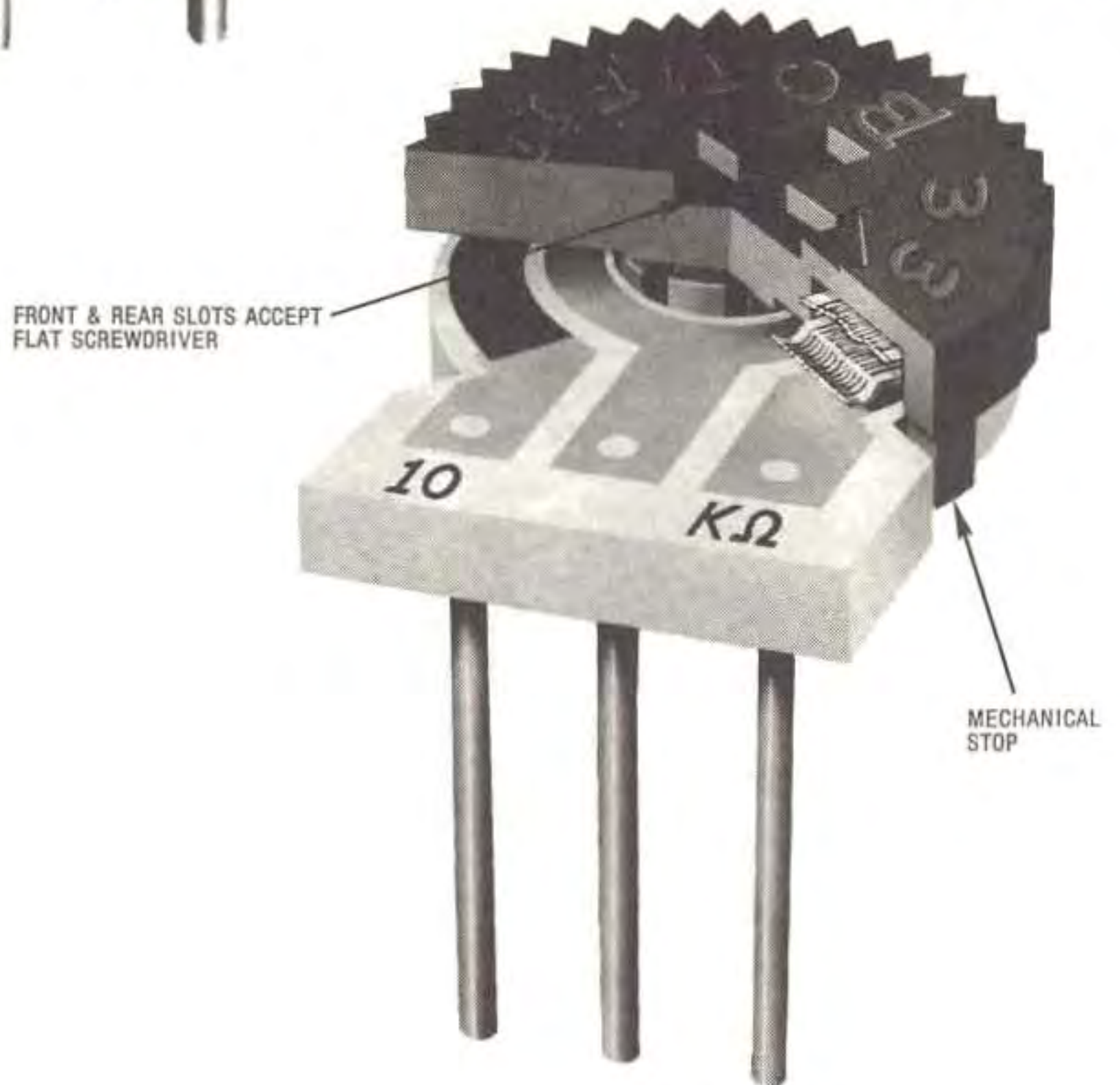

Fig. 7-33 Example of single-turn adjustment potentiometers



precision linear position feedback transducers, are several feet long. The wiper is tied directly to some moving member of the system.

The device shown in Fig. 7-35 is frequently used as an audio level control in the mixer panel used in a recording studio. It enables the operator to make rapid level changes and visually compare relative settings in an instant. Similar devices are also used in consumer music systems.

## HOUSINGS

The housing of a potentiometer is very important. Much of the environmental qualities of the potentiometer are directly related to its enclosure. The degree of sealing achieved will dictate the ability of the unit to withstand moisture cycling. Although a quality potentiometer designed for harsh environments has an effective seal, it should never be considered hermetic (airtight).

The housing aids in stability and quiet performance by shielding the element and contact wiper surfaces from dust and dirt which will cause noisy operation. A good seal will aid in keeping out vapors which will cause oxide and film buildup on the element as well as on the wiper.

One of the major functions of any potentiometer housing is mechanical structure management. It is the framework which holds all of the other working members in their proper positions. This is especially true with precision potentiometers where the housing must keep the resistance element from changing shape or position with a changing outside environment.

The potentiometer housing must be properly designed to allow easy (and hence low cost) assembly. The inside of a well designed housing will have a variety of self jiggling and holding features for various parts that make up the assembly. This provides a high quality level for a given cost.

The housing also provides the mechanical means for holding the leads or terminals secure-

ly in place. Mechanical stress and strain or elevated temperatures involved in soldering must be isolated from the internal members of the potentiometer. This prevents mechanical and electrical installation from affecting performance.

Economical manufacture of housing requires the use of complicated molds and molding presses of the type shown in Fig. 7-36.

## SUMMARY

In order to select the most cost-effective potentiometer for a particular application, the user should be familiar with the many standard options available in potentiometer performance and construction. Application requirements can be matched against these options to make a final decision.

The tables in Fig. 7-37 are designed to aid this selection process in a general way. Where meaningful, specification and requirements are listed with those of lowest cost first in each category. These are marked with an asterisk (\*). Element costs increase from left to right. By noting the application requirements of interest, the user can read the table to select standard resistive choices. Selection of a specific potentiometer design can then be decided based on severity of requirements vs. capability of the construction features as discussed in this chapter.

For unusually critical applications, the right side of the tables will alert the reader to important construction considerations relative to certain specifications that should be investigated with the potentiometer manufacturer before making a final product selection.

Methodical use of these tables will lead to the selection of construction features that best match a particular application. Data sheets from specific manufacturers can then be consulted to select a specific potentiometer model or type. Of course, packaging factors in Chapter Eight and other considerations discussed elsewhere in this book should influence the final choice of a potentiometer for the most cost-effective application.





**Fig. 7-34** This linear actuated unit is used to provide position feedback in a linear system

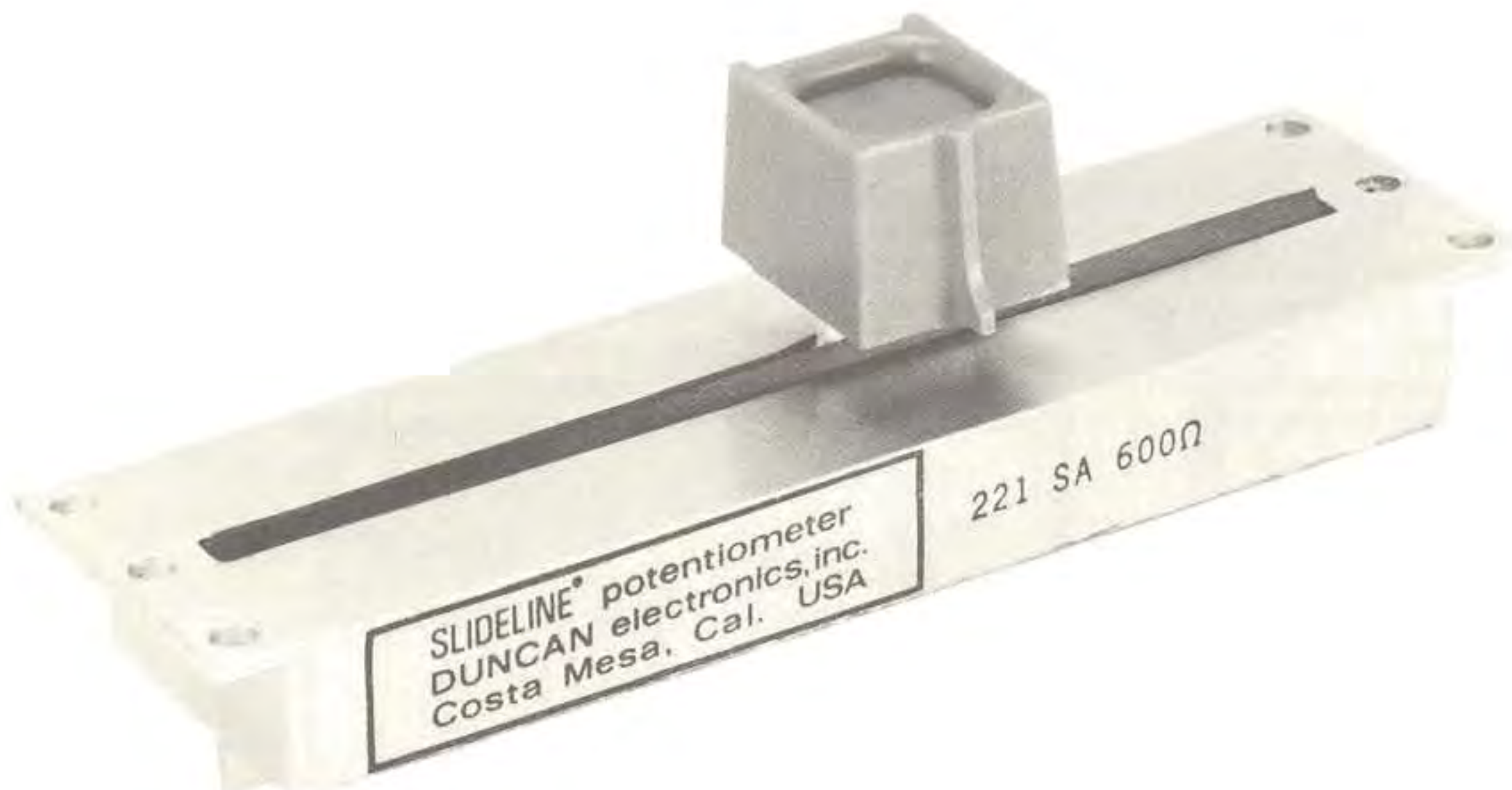

**Fig. 7-35** Slider potentiometers such as this are frequently used in audio controls in studio mixer panels (Duncan Electronics, Inc. a subsidiary of Systron Donner)





**Fig. 7-36** Precision potentiometer housings are molded by equipment such as this press



A. TRIMMER SELECTION GUIDE FOR COST-EFFECTIVE APPLICATIONS								
APPLICATION REQUIREMENTS	STANDARD RESISTIVE ELEMENT CHOICES				CONSTRUCTION CONSIDERATIONS FOR CRITICAL APPLICATIONS (1)			
ELECTRICAL	Carbon	Cermet	Wirewound	Metal Film (2)	Wiper	Terminals	Actuator/Shaft Single-turn Multi-turn	Housing/ Mounting
Total Resistance, ohms 2 - 10 10 - 20K 20K - 50K 50K - 2 meg 2 meg - 5 meg		X X X	X X	X X				
*Total Resistance Tolerance, % max. (4) ±20 ±10 ± 5	X	X X	X X X	X X X				
Voltage Divider Adjustability % (3) .05 - .11 .11 - .50 .50 - 1.90	X	X X X	2k-50k 10-2k	X X X	X		X	
Current Rheostat Adjustability % (3) .05 - .11 .11 - .50 .50 - 1.90	X	X	2k-50k 10-2k	X	X		X	
*Power, watts max. at 70°C .25 .50 1.00	(1) X	X X X	(1) X X X	X X	X			X
*Equivalent Noise Resistance, ohms max. (4) 100 10			X	X X	X			
*Contact Resistance Variation, % max. (4) 2.0 1.0	X	X X			X			
Circuit Frequency, Hertz DC — 1kHz DC — 250kHz DC — 1MHz	X X X	X	X	X X X			X	X
*TEMPERATURE Temperature Coefficient, PPM/°C, Max. (4) ±400 ±100 ± 50 ± 10	X	X X	X X X	X X X				X
*Operating Temperature °C (4) —55 to +105 —55 to +150 —55 to +175	X	X X X	X X X	X X				X
MOISTURE RESISTANCE *Humidity (4) Poor Good	X	X	X	X				X
MECHANICAL *Rotational Life Cycles Maximum 200 cycles over 200 cycles	X X	X	X	X X	X		X	
INSTALLATION Exposure to: Flux Solder Temp Solvents	X	X X X	X	X X		X		X X X
*RELATIVE UNIT COST (5) a. (lowest cost) b. c. d. (highest cost)	X	X	X	X	Special materials, processes and testing may greatly increase product cost.			

Fig. 7-37 Selection guides for cost-effective applications



**B. PRECISION POTENTIOMETER SELECTION GUIDE  
FOR COST-EFFECTIVE APPLICATIONS**

APPLICATION REQUIREMENTS	STANDARD RESISTIVE ELEMENT CHOICES			CONSTRUCTION CONSIDERATIONS FOR CRITICAL APPLICATIONS (1)		
	Wirewound	Conductive Plastic	Hybrid W.W./C.P.	Wiper	Housing	Bearings
<b>ELECTRICAL</b>						
Total Resistance, ohms (1) 25 - 100 100 - 500K 500K - 1 Meg	X X	X X	X			
*Total Resistance Tolerance, % ±10 - ±20 ±10 ±3 - ±5	X	X	X			
*Resolution, % (3) (4) .009 - .090 Essentially Infinite	X	X	X			
*Linearity, independent Maximum, % (1) ±0.50 - ±1.00 ±0.15 - ±0.50	X	X X	X			
Equivalent Noise Resistance, Ohms (4) 100	X			X		
Output Smoothness, % (4) 0.1		X	X	X		
Power, Watts max. at 70°C (1) (or max. applied voltage) 1.0 - 2.0 2.0 - 5.0	X X	X	X		X	
Circuit Frequency, Hertz DC - 1kHz DC - 1MHz	X	X X	X			
<b>TEMPERATURE</b>						
*Temperature Coefficient, PPM/°C max. (3) (4) ±200 ±100 ±50	X	X(2)	X		X	
*Operating temperature, °C (4) -55° to 125°C -55° to 150°C	X X	X	X		X	
<b>MOISTURE RESISTANCE</b>						
Fair Good	X	X	X		X	
<b>MECHANICAL</b>						
*Rotational Life, Shaft Revolutions, max. 2,000,000 10,000,000 25,000,000	X	X	X			X
Torque	Depends on Specific design higher torque is least expensive					X
<b>RELATIVE UNIT COST (5)</b>						
1. (Lowest cost) 2. 3.	X	X	X		X	

**NOTES TO SELECTION GUIDES**

- (1) Where certain specifications and performance are critical users may wish to discuss related key construction features of a particular potentiometer with the manufacturer.
- (2) Includes "bulk metal".
- (3) Specifications vary considerably depending on size and design of the resistive element, specific resistance and price. Check manufacturer's data sheet before final selection.
- (4) When specifying potentiometers, care should be taken to match specifications to related type of element. As examples, when specifying conductive plastic precisions, do not call out wirewound specifications such as equivalent noise resistance or a TC of ±50 PPM. When specifying cermet trimmers do not call out ±10 PPM TC which is available only with metal film.
- (5) Unit cost should be only one consideration for cost-effective application of potentiometers. See text for other factors.
- (\*) Specifications and requirements that generally result in a lower cost potentiometer are listed first. With other things being equal, first item will generally be most economical for that particular specification.





*In spite of the rapid technological advances and the growth of a discipline, electronic packaging is not easily defined in terms of some already existing technology. Rather, it is an overlapping of disciplines, which requires a breadth of knowledge rarely encountered before in emerging disciplines. While there may be no perfect definition of electronic packaging, it may, for practical purposes, be considered as the conversion of electronic or electrical functions into optimized, producible, electro-mechanical assemblies or packages. True, electromechanical assembly is not new, as electrical equipment has always required some mechanical form factor; however, the binding of sound interdisciplinary principles into a single discipline of electronic packaging is new.*

*Charles A. Harper*

*Handbook of Electronic Packaging, 1969*

## INTRODUCTION

Information in earlier chapters dealt primarily with the electrical characteristics and proper application of potentiometers. Another important consideration when selecting potentiometers is the physical manner in which the unit will be packaged into the overall system. Chapter six includes special mounting requirements for precision potentiometers and should be studied if precisions are of interest.

The purpose of this chapter is to remind the user of those common sense facts of electronic packaging applicable to potentiometers. The material presented, while second nature to the experienced designer, provides an excellent guide to anyone involved with variable resistive components. Circuit designers and packaging engineers are urged to give *early* consideration to the

ultimate need for and placement of potentiometers (especially trimmers) to avoid future frustration of a technician as in Fig. 8-1.

## PLAN PACKAGING EARLY

All too often, insufficient planning and care results in a potentiometer being placed in an inaccessible location where the maintenance or calibration person cannot get to the potentiometer at all or must practically disassemble the instrument before the adjustment can be made. This is particularly true of trimmers and especially those that are added at the end of the design check-out stage when it is finally realized that an adjustment *will* be needed in the circuit.

**Trimmers.** Fig. 8-2 and 8-3 illustrate some ways to make trimmers accessible.





**Fig. 8-1** Planning ahead can avoid frustrations of the calibrations personnel

## DETERMINE ACCESSIBILITY NEEDS

**General.** As an initial step, think about who is going to be making the adjustments, how often, and under what conditions. Try to visualize the entire adjustment process.

If the adjustment is to be made fairly often, such as once or twice a day for calibration, then the potentiometer shaft or actuator should be accessible without having to take the instrument or equipment apart. On the other hand, it might be that a particular adjustment should be made *only* by very skilled technicians with elaborate test equipment. To make this adjustment too easily available, say from the front panel, would be to invite disaster! This type of adjustment is best hidden by a service panel or placed at the back of equipment depending on accessibility of the latter.

Some adjustments are made only when the instrument or system has experienced a critical component failure, and compensation for replacement component variations is required. In this case it is probable that the top cover of the equipment will already have been removed for maintenance, so placing the potentiometer such that it is accessible under these conditions is adequate and probably wise.

Watch out for subassemblies! If the initial adjustment is made in subassembly state, consider whether that same adjustment might have to be varied in the field after all panels, switches, controls, etc., are in place. Maybe a special extender card or cable harness is used by factory assembly personnel is making initial calibrations; will a maintenance man in the field have those same accessories? If not, then make sure he can gain proper access to all the adjustments he will be required to make.

It is usually easy to make all the necessary adjustments on an instrument when it is sitting alone on a bench. Think what happens when it is installed in a big rack cabinet with other equipment above, below, and even behind it. Will it be necessary to pull the instrument out of the rack in order to make minor adjustments? Try to eliminate or minimize this type of maintenance.

On one line of instruments now on the market, a minor operational amplifier drift adjustment requires setting a particular trimmer. Unfortunately, three circuit cards have to be removed before the potentiometer can be reached for adjustment. The fact that all the cards have to be in place during the adjustment made life most difficult for service personnel.



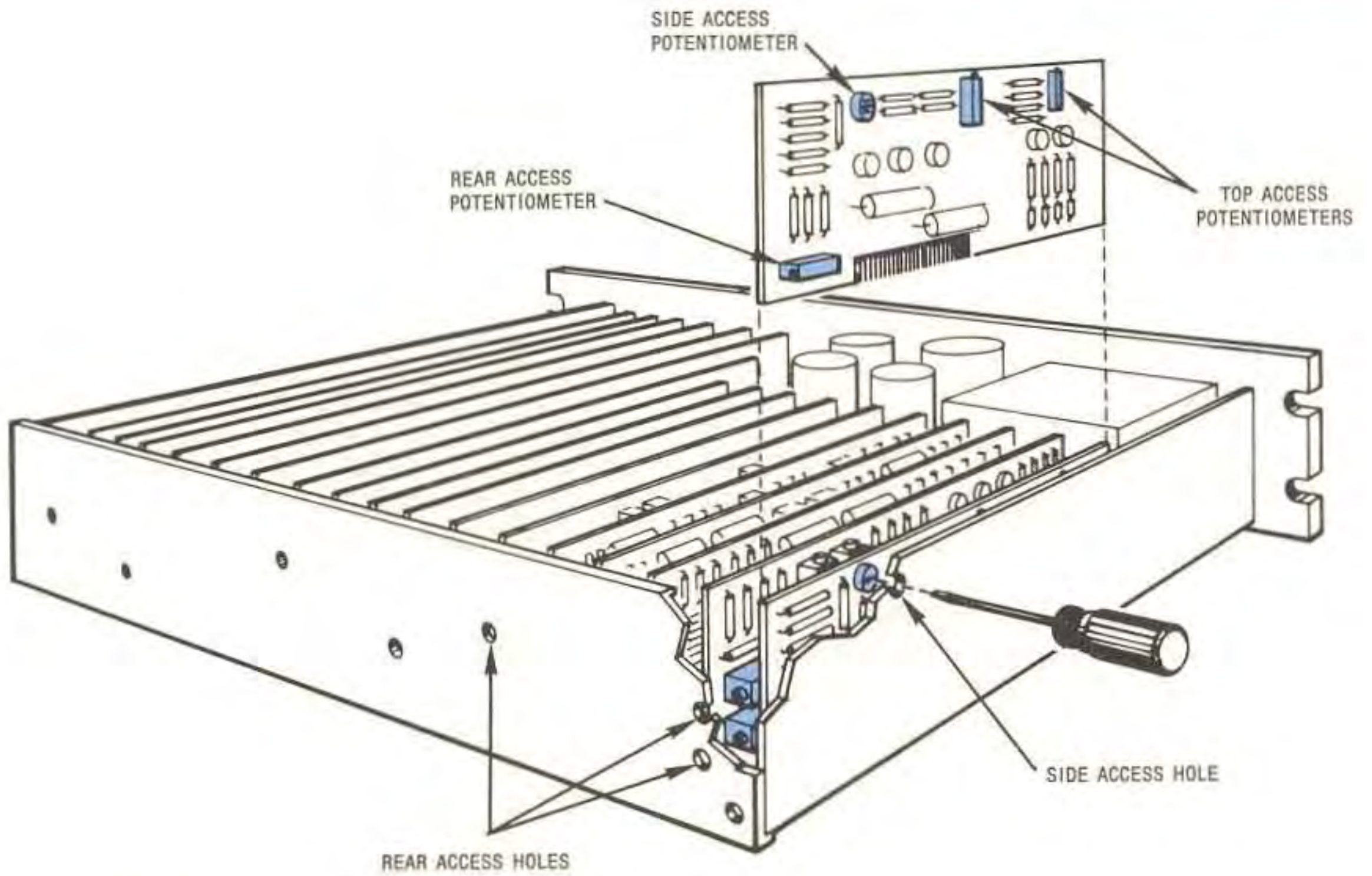

**Fig. 8-2** Access to trimmers on PC cards mounted in a cage can be provided by careful placement of potentiometers near the top or rear

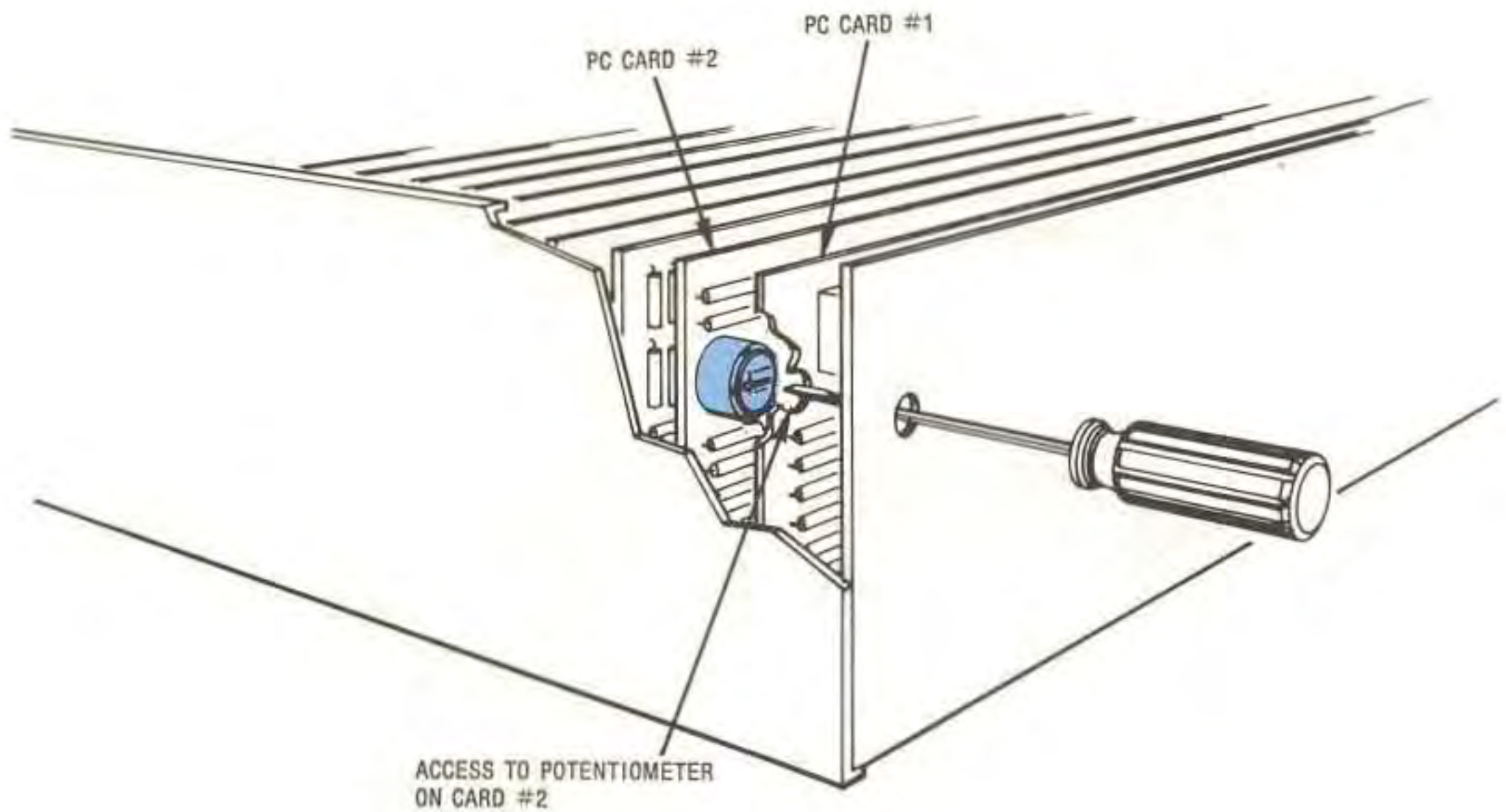

**Fig. 8-3** Access hole provided through one PC card permits adjustment of potentiometer on another card



## CONSIDER OTHER PACKAGING RESTRICTIONS

**General.** There are other restrictions which may limit the choices in designing with potentiometers. For example, front panel space may not be available to include all of the required controls and leave room for adjustment access. Harsh environment during operation may make it necessary to provide moisture seals or other protection over access holes and around adjustment shafts.

Potentiometers may be used in critical circuits that will not allow long leads or printed circuit runs because of unwanted stray capacitance or possible noise pickup. This means that the entire critical circuit must be fabricated with all the components, including the potentiometer, in proximity. If the circuit must be packaged in an inaccessible area of the assembly, an extension can be attached to the adjustment shaft. Another consideration is undesirable capacitance or noise introduced by an ordinary screwdriver during the adjustment process. It might be necessary to use only a nonconducting screwdriver. Information of this type should be included in the service manual.

**Trimmers.** Location of a particular trimmer on a printed circuit card may be influenced by other components. For example, it is not wise to place a critical trimming potentiometer adjacent to a high-power resistor that radiates a significant amount of heat.

Practical packaging techniques can also dictate potentiometer mounting positions. Various trimmers may be scattered over a given printed circuit card, but only one access direction for adjustment is available. The layout designer must carefully arrange all of the circuit components so that all trimmers can be adjusted from the same direction without obstruction by adjacent components.

The metal adjustment screw in the typical trimmer potentiometer is not electrically connected to any terminal. In a rectangular or square multiturn potentiometer, there is a certain amount of distributed capacitance between the metal shaft and the element. If the potentiometer is at a low level, high impedance point in a circuit, it may be necessary to use a metal bushing mounted potentiometer which allows the shaft to be grounded.

## CHOOSE THE PROPER PHYSICAL FORM

**General.** Potentiometers are available in many different mechanical variations. Fig. 8-4 illustrates some of the possible choices for trimmer potentiometers. Often, equivalent electrical performance may be obtained with different physical

shapes and sizes. The mounting means may be chosen from a variety of possibilities. Terminal choices include wire leads, printed circuit pins, and solder lugs.

For some applications, physical size limitations will be one of the determining factors. In other cases, the necessary direction of adjustment access will be more important.

Application in precision servo systems may require a servo mounted potentiometer (Chapter 6) or other factors may make a bushing mount more practical. Proper choice of a potentiometer for any application requires consideration of all physical and electrical requirements. For specifications such as power, size is often the controlling factor and adequate mounting space must be allowed.

The Potentiometer Packaging Guides, Fig. 8-4 thru Fig. 8-7, shows some common mounting areas and space occupied above or behind the mounting area for adjustments, controls, and precisions. These are intended as *general guidelines* to help in planning adequate space for mounting variable resistive components.

Before making a final selection, check the specific product data sheet and confirm that the potentiometer size vs. specifications and performance (Chapter 7) are within possible circuit design requirements. To be conservative, leave room for the next larger sized potentiometer. This could simplify a future circuit redesign that may not be contemplated at this early stage.

## MOUNTING METHODS

**Trimmers.** Potentiometers may be installed or physically mounted in many different ways. In simple applications, printed circuit pin trimmers may be inserted directly into the printed circuit card and wave soldered. This gives both electrical connection and mechanical mounting. It is wise to use large enough lands (printed circuit conductor around hole) on printed circuit boards to prevent pulling off the copper circuitry during adjustment. In designs which must be capable of withstanding severe mechanical vibration and shock, it would be wiser to use a more substantial mounting means. Consider screw mounted potentiometers or conformal coatings in the circuit board assembly. Reinforcing a pin mounted unit with cement is another possibility.

Trimmers with mounting holes may be grouped together with screws or threaded rod, and angle brackets to mount the complete assembly to a panel or circuit board.

Mounting requirements are often determined by access demands as discussed earlier. Consider the drawing of Fig. 8-8. A printed circuit mounted potentiometer is placed right at the



### POTENTIOMETER PACKAGE SELECTION GUIDE

Common potentiometer mounting areas and space requirements shown actual nominal size. Dimensions are in inches. Photo shows typical devices.

#### ADJUSTMENTS

RECTANGULAR MULTITURN	MOUNTING AREA & NOMINAL KEY DIMENSION	
SQUARE MULTITURN	MOUNTING AREA & NOMINAL KEY DIMENSION	
ROUND/SQUARE SINGLE TURN	MOUNTING AREA & NOMINAL KEY DIMENSION	

Note: Normal circuit board areas shown. Adjustment shaft, if any, and terminals not included. Some units may mount on side or edge. For final selection, see manufacturer's data sheets for options including terminal and actuator location.



Fig. 8-4 Adjustment potentiometer package selection guide



**POTENTIOMETER PACKAGE SELECTION GUIDE**

Common potentiometer mounting areas and space requirements shown actual nominal size. Dimensions are in inches. Photo shows typical devices.

**CONTROLS**

<p>MOUNTING AREA AND NOMINAL DIAMETER</p>	
<p>SPACE OCCUPIED BEHIND MOUNTING SURFACE EXCLUDING TERMINALS</p>	
<p>MOUNTING AREA AND NOMINAL DIAMETER</p>	
<p>SPACE OCCUPIED BEHIND MOUNTING SURFACE EXCLUDING TERMINALS</p>	



**Fig. 8-5** Control potentiometer package selection guide



**POTENTIOMETER PACKAGE SELECTION GUIDE**

Common potentiometer mounting areas and space requirements shown actual nominal size. Dimensions are in inches. Photo shows typical devices.

**PRECISIONS — TEN TURN (1)**

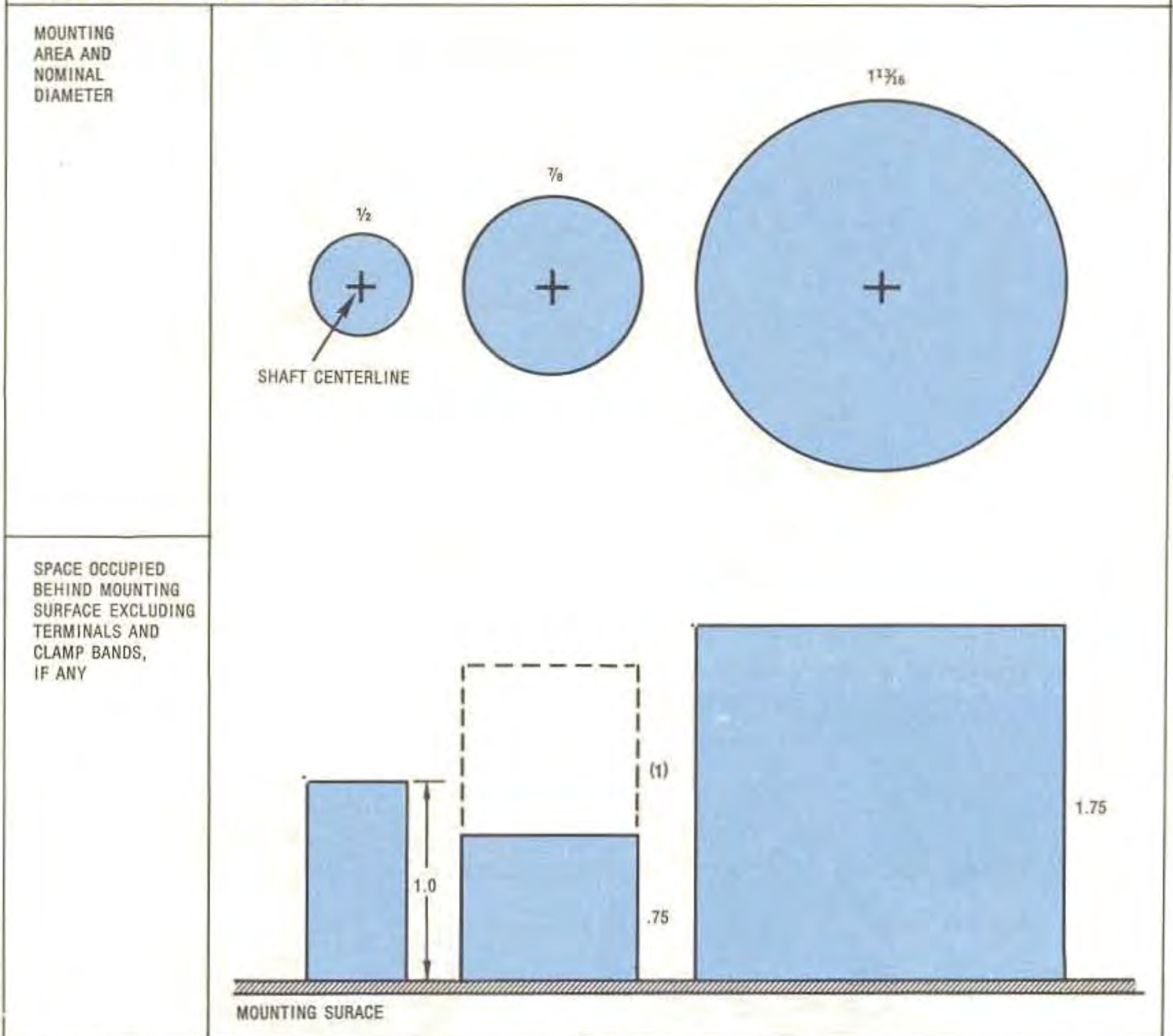

NOTES — Continued

(1) Multiturn precisions vary greatly in length depending on number of turns, specifications and specific design. See manufacturer's data sheets.



**Fig. 8-6** Precision ten turn potentiometer package selection guide



**POTENTIOMETER PACKAGE SELECTION GUIDE**

Common potentiometer mounting areas and space requirements shown actual nominal size. Dimensions are in inches. Photo shows typical devices.

**PRECISIONS — SINGLE TURN**

<p>MOUNTING AREA AND NOMINAL DIAMETER</p>	
<p>SPACE OCCUPIED BEHIND MOUNTING SURFACE EXCLUDING TERMINALS AND CLAMP BANDS, IF ANY</p>	
<p>MOUNTING AREA AND NOMINAL DIAMETER</p>	
<p>SPACE OCCUPIED BEHIND MOUNTING SURFACE EXCLUDING TERMINALS AND CLAMP BANDS, IF ANY</p>	

Fig. 8-7 Precision single turn potentiometer package selection guide



### POTENTIOMETER PACKAGE SELECTION GUIDE

Common potentiometer mounting areas and space requirements shown actual nominal size.  
 Dimensions are in inches. Photo shows typical devices.

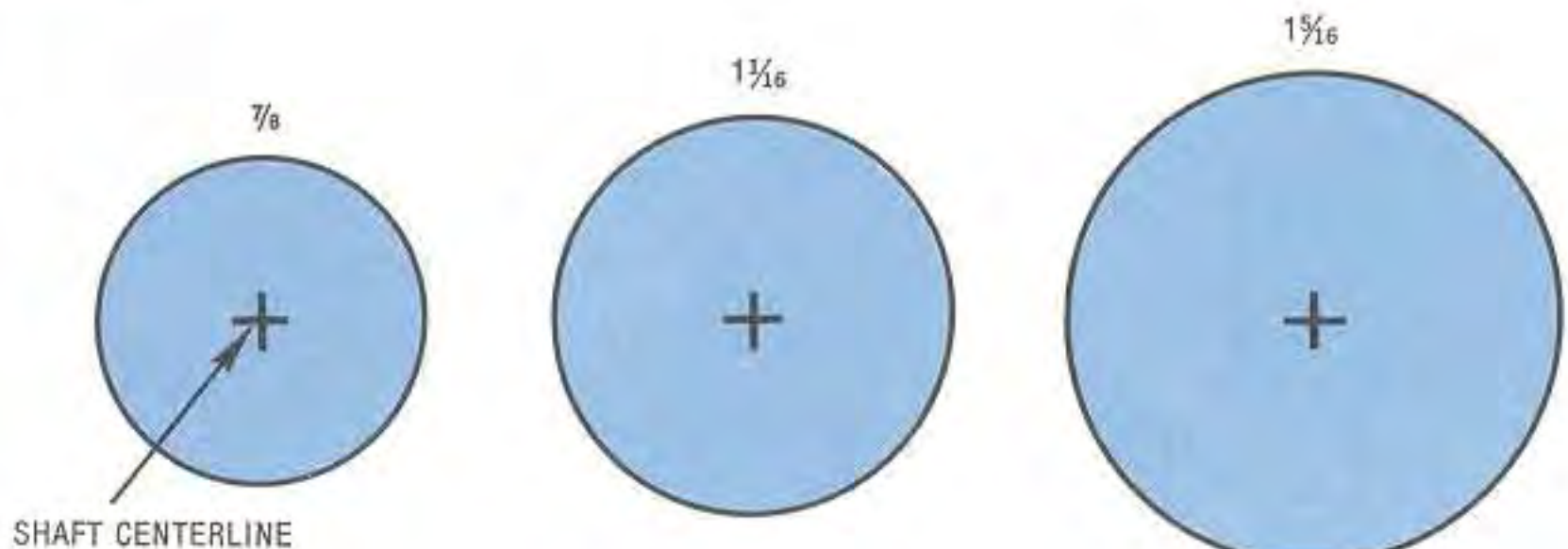
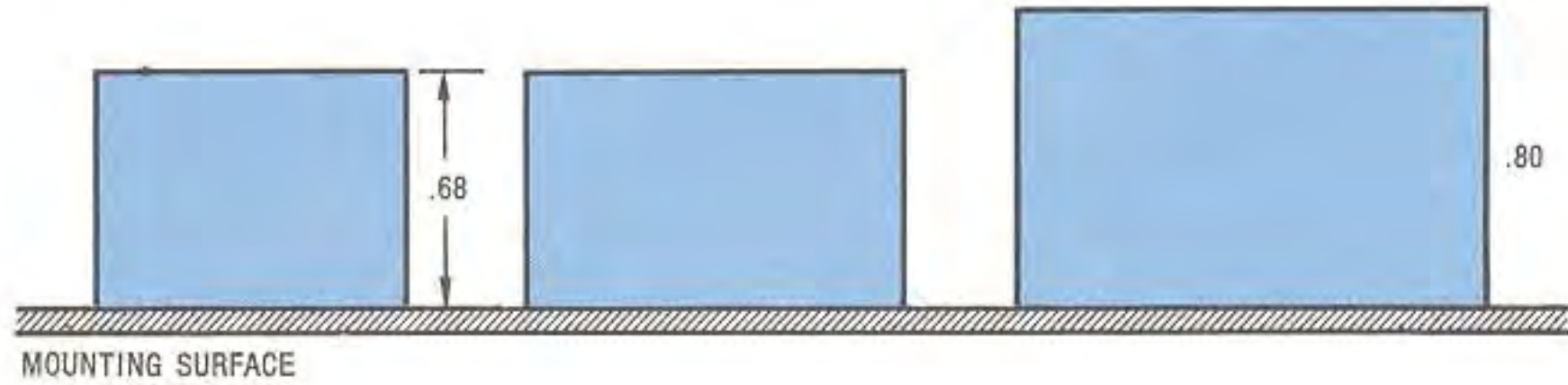
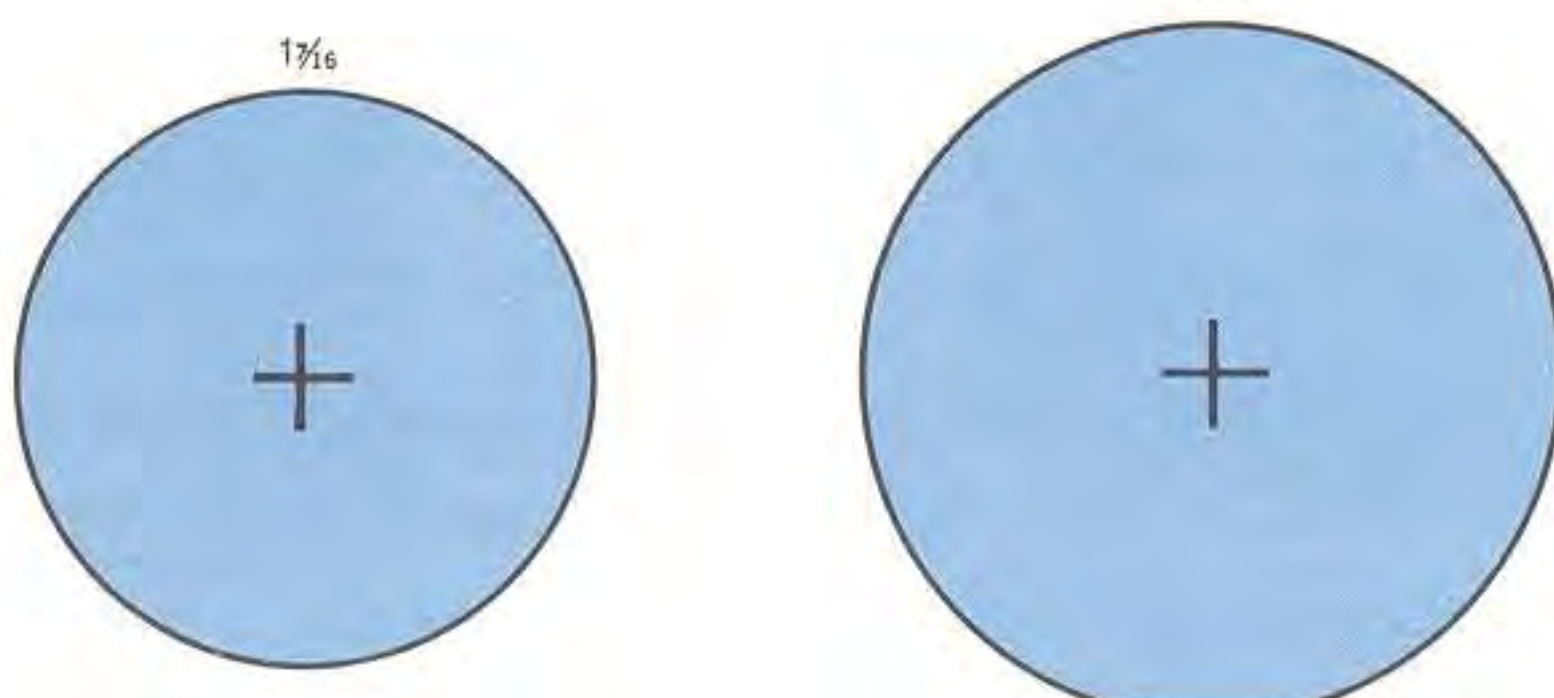
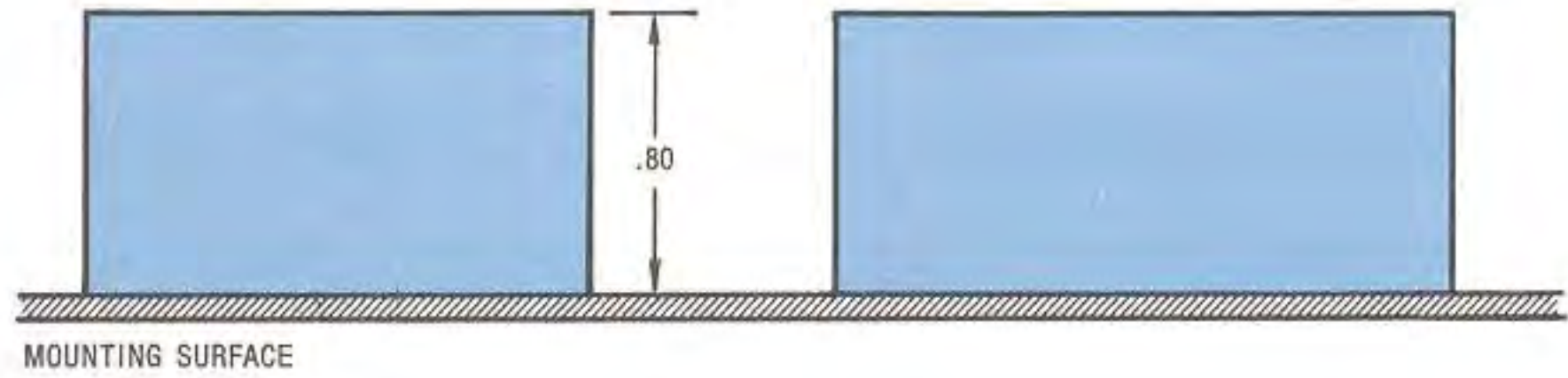
#### PRECISIONS — SINGLE TURN

MOUNTING  
 AREA AND  
 NOMINAL DIAMETER

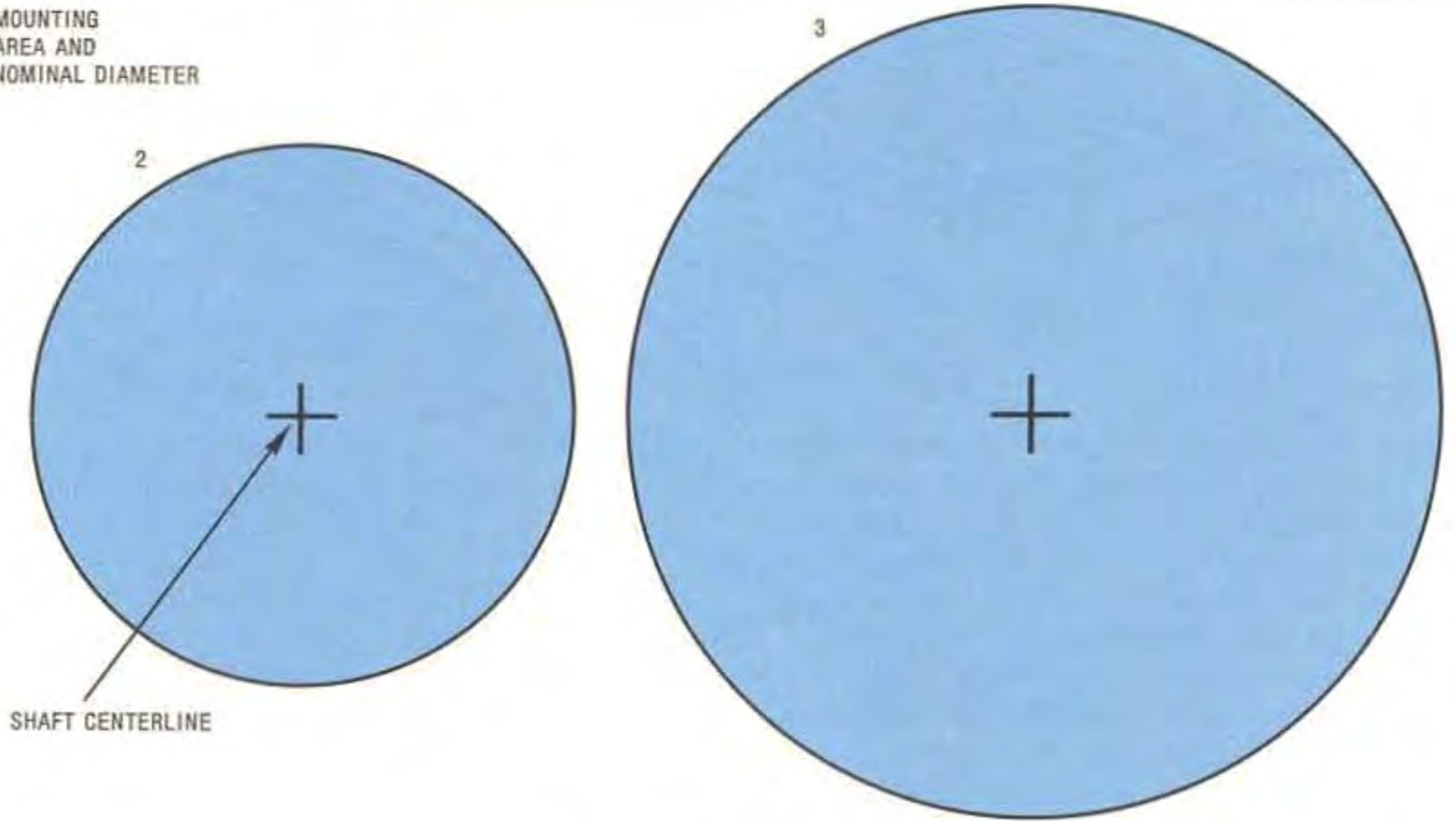

SHAFT CENTERLINE

SPACE OCCUPIED  
 BEHIND MOUNTING  
 SURFACE EXCLUDING  
 TERMINALS AND  
 CLAMP BANDS,  
 IF ANY

.85

MOUNTING SURFACE

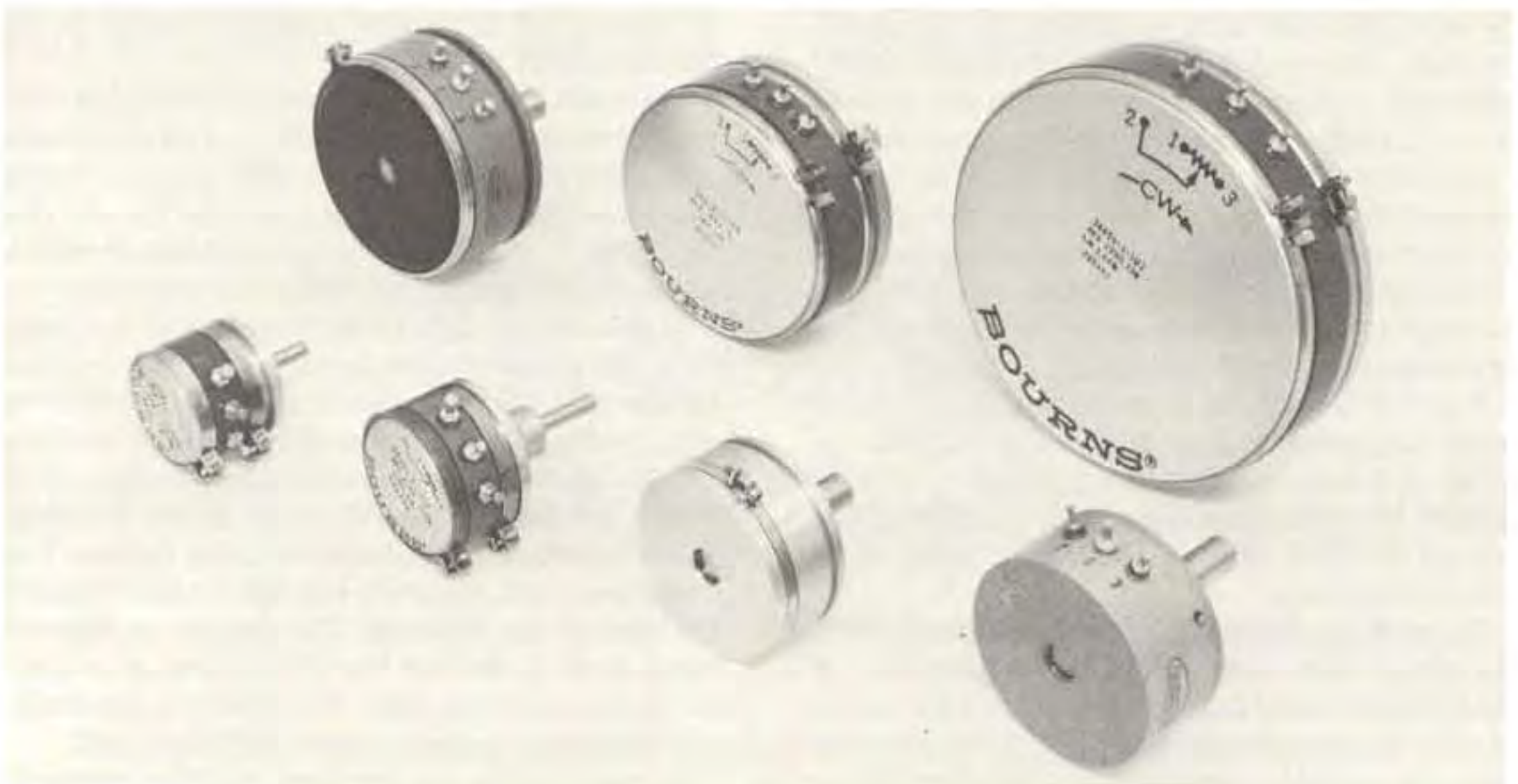



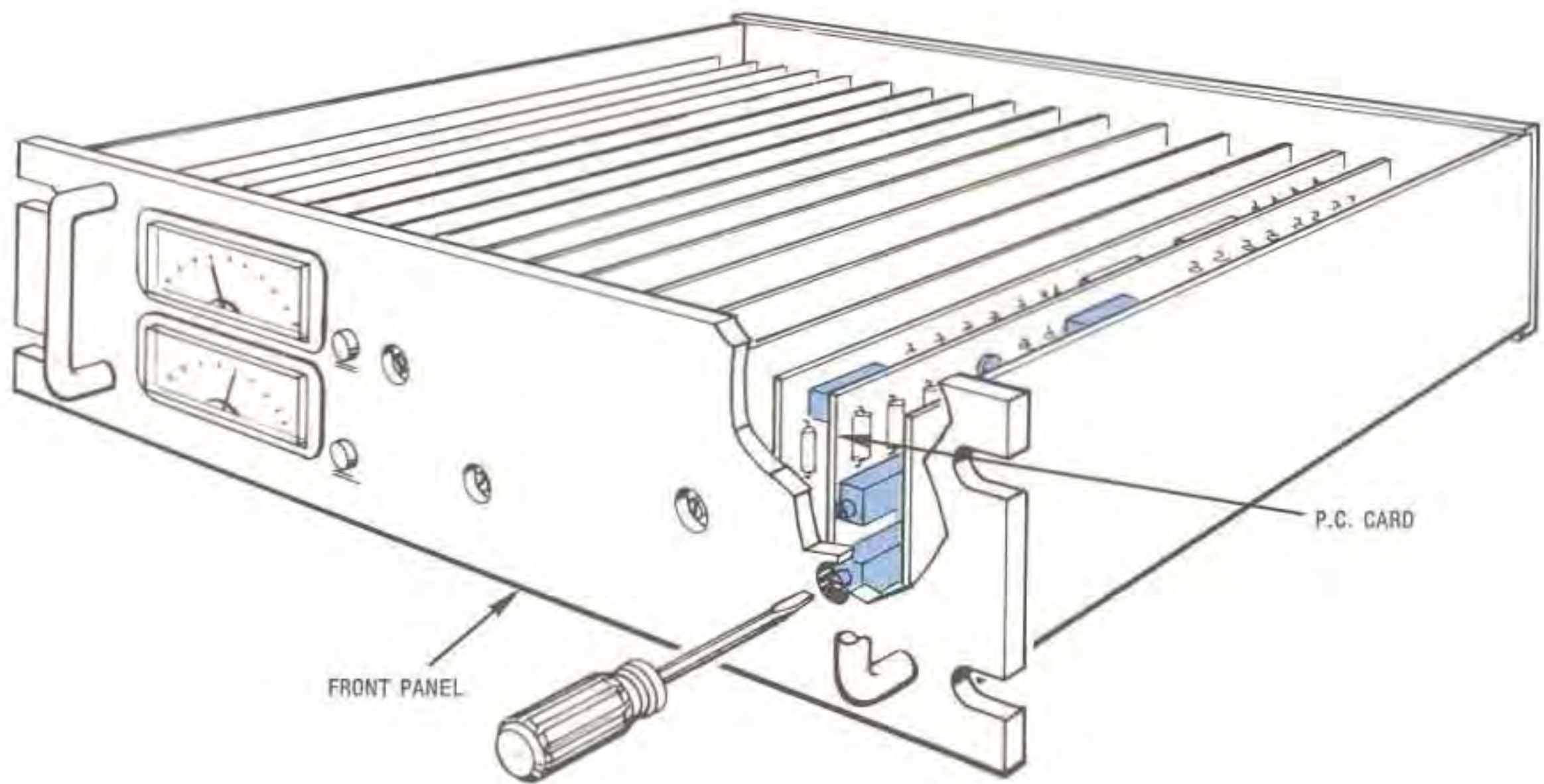

Fig. 8-8 Trimmer potentiometer access through front panel

edge of the card in such a manner that the small adjusting head may be inserted into an access hole in the front panel. The hole provides a limited access filter in that a rather small screwdriver is required in order to make an adjustment. Where the head is actually in the hole in the panel, the hole acts as a guide for the adjusting tool. The major limitation to this type of approach is the necessity of pulling the printed circuit card directly away from the panel. Where a plug-in card is used, it may be that the potentiometer must be pulled back from the edge of the card. It will usually be necessary to provide a larger access hole for this arrangement to allow for mechanical tolerances so the screwdriver and adjustment shaft will line up.

Fig. 8-9 illustrates a mounting variation in which the entire body of the potentiometer is inserted in a hole in the printed circuit card. This reduces the maximum seated height by the thickness of the card, and thus permits closer board-to-board spacing.

In some applications, adjustment access from the circuit side (side opposite components) of the printed circuit card is necessary. This can be done in the manner shown in Fig. 8-10. The wire pins are carefully bent over, as described in the

next section, to permit inverted installation of the potentiometer. A small amount of cement to solidly secure the trimmer in place is good insurance against possible damage during adjustment. If this approach is used where the printed circuit cards are wave soldered, the entire hole should be masked off to prevent possible damage to the potentiometer.

**Controls.** Control type potentiometers are normally bushing mounted directly to an externally accessible panel, although limited access controls might be mounted on a bracket inside the assembly and adjustment accomplished with a screwdriver inserted through an access hole.

Applications such as those discussed in Chapter 5 use a mounting style convenient for manual adjustment. The style shown in Fig. 8-11 is known as a bushing mount. Note the threaded bushing on the front of the unit and the operating shaft which extends beyond the end of the bushing. Some bushings incorporate a locking feature. The operating shaft generally extends  $\frac{1}{2}$  inch beyond the end of the bushing. This length of exposed shaft is adequate for the attachment of a knob or turns counting dial. The shaft is generally available with a plain, slotted, or flatted end.

It may be that an insulated shaft extension is



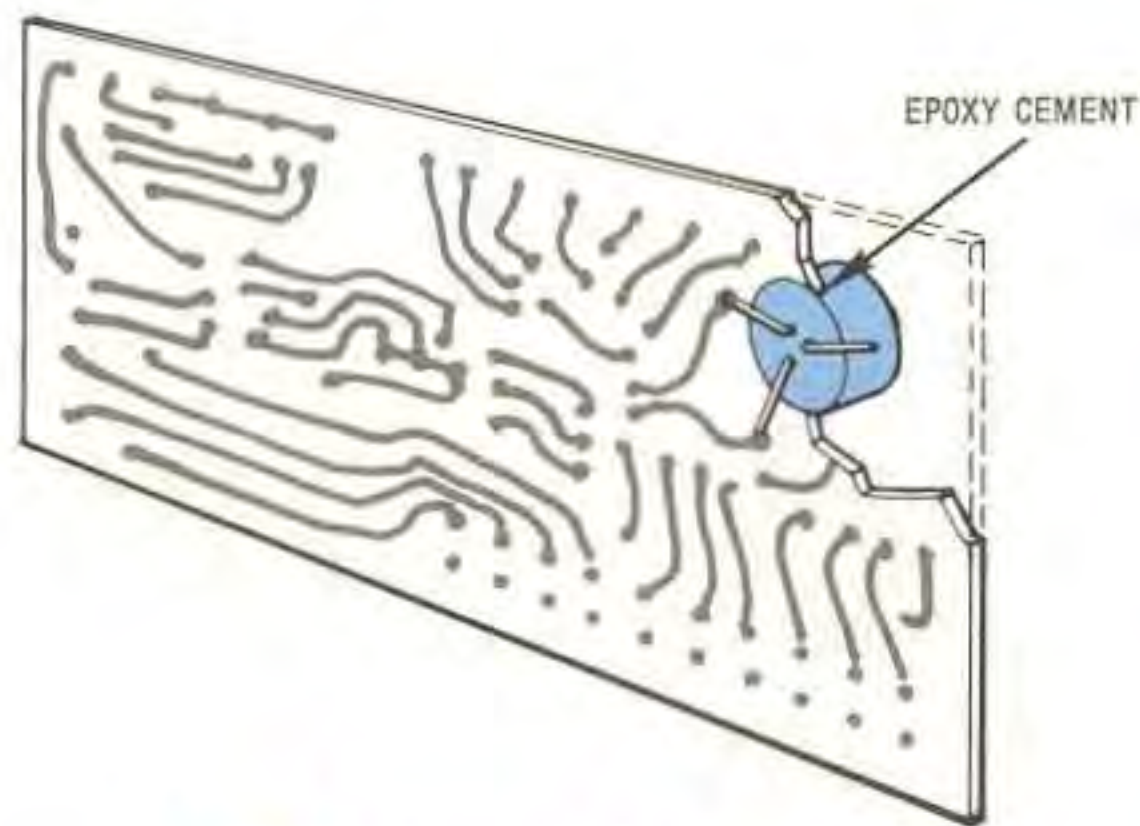

**Fig. 8-9** Low-profile mounting

necessary to provide isolation in critical low-level circuits, applications where distributed capacitance may be important, or where the operating voltage is high.

Snap-in mounting is convenient, economical and especially satisfactory where shock and vibration are not a major concern. These designs reduce the installation labor costs involved by eliminating the threaded bushing, nut, and lock-washer. The potentiometer is simply pressed into a drilled or punched hole until the locking fingers snap into place. Care should be taken in selecting mounting hole size and panel thickness when packaging snap-in type potentiometers. Appearance from the front of the panel is cleaner looking than nuts, washers, and other retainers. Fig. 8-12 shows products with snap-in mounting including a rectangular push-button potentiometer. The bezel on the latter model provides a neat appearance without extra mounting hardware.

A rigid printed circuit board placed behind and parallel to a front panel is a good way to mount and interconnect components. Controls that are

to be adjusted from the front of the panel are mounted on the PC board with adjustment shafts extending through the panel. Mounting and wiring of front panel components and related devices is simplified by eliminating individual wires. Fig. 8-13 illustrates this packaging technique.

In cases where the printed circuit board is at right angles to a panel, mounting such as that shown in Fig. 8-14 may be used. In this arrangement, the terminals of the potentiometer are soldered to the printed circuit board and a supporting bracket is soldered or mechanically clamped in place. This eliminates the need for a more complex bracket that might require screws for attachment and a nut and washer on the potentiometer. The adjustment devices can be mounted at varying distances behind the panel for greater front panel packaging density.

A wide variety of mounting hardware is available to make component packaging easier as illustrated in Fig. 8-15. These accessories are available directly from the potentiometer distributor or manufacturer.

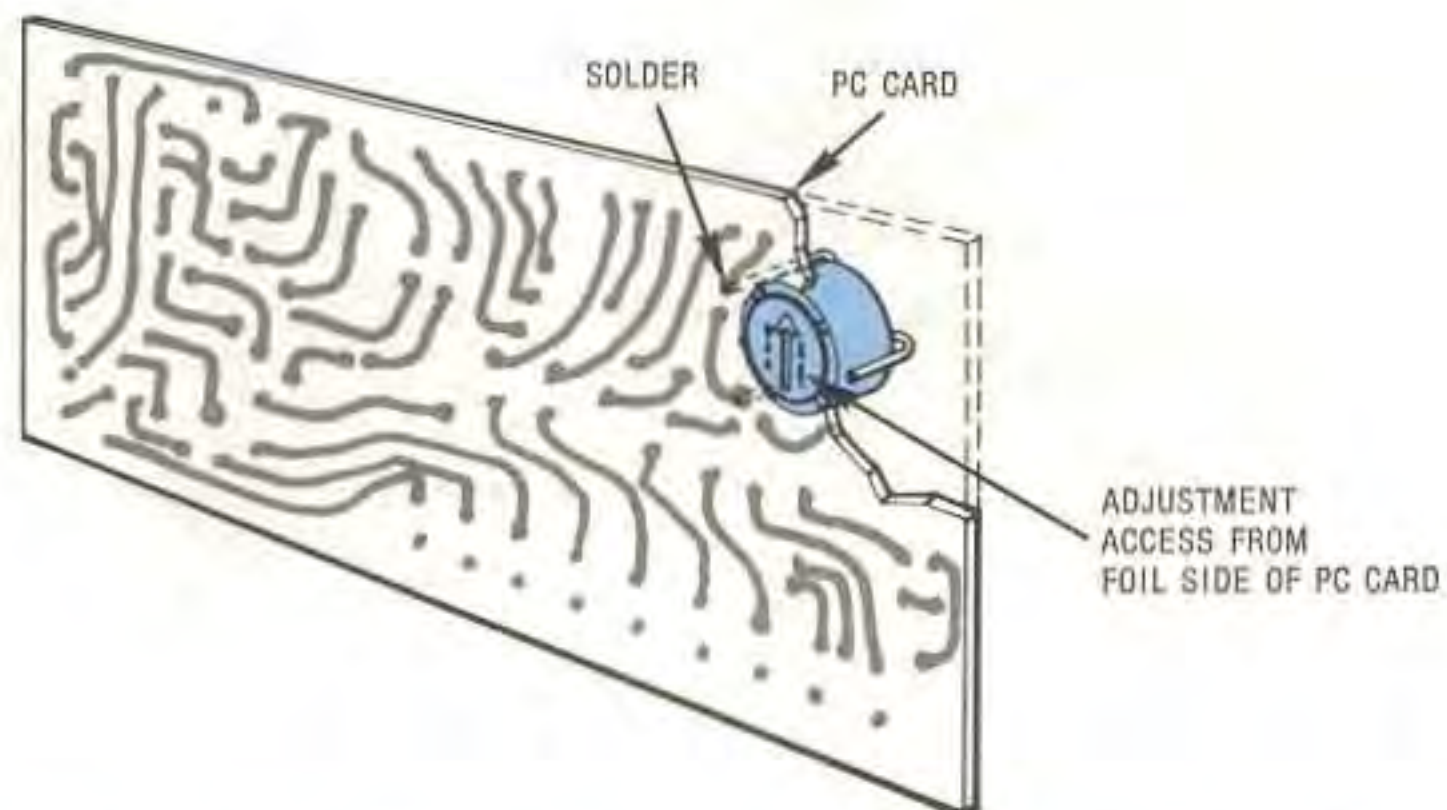

**Fig. 8-10** Potentiometer mounted inverted to permit foil-side adjustment access



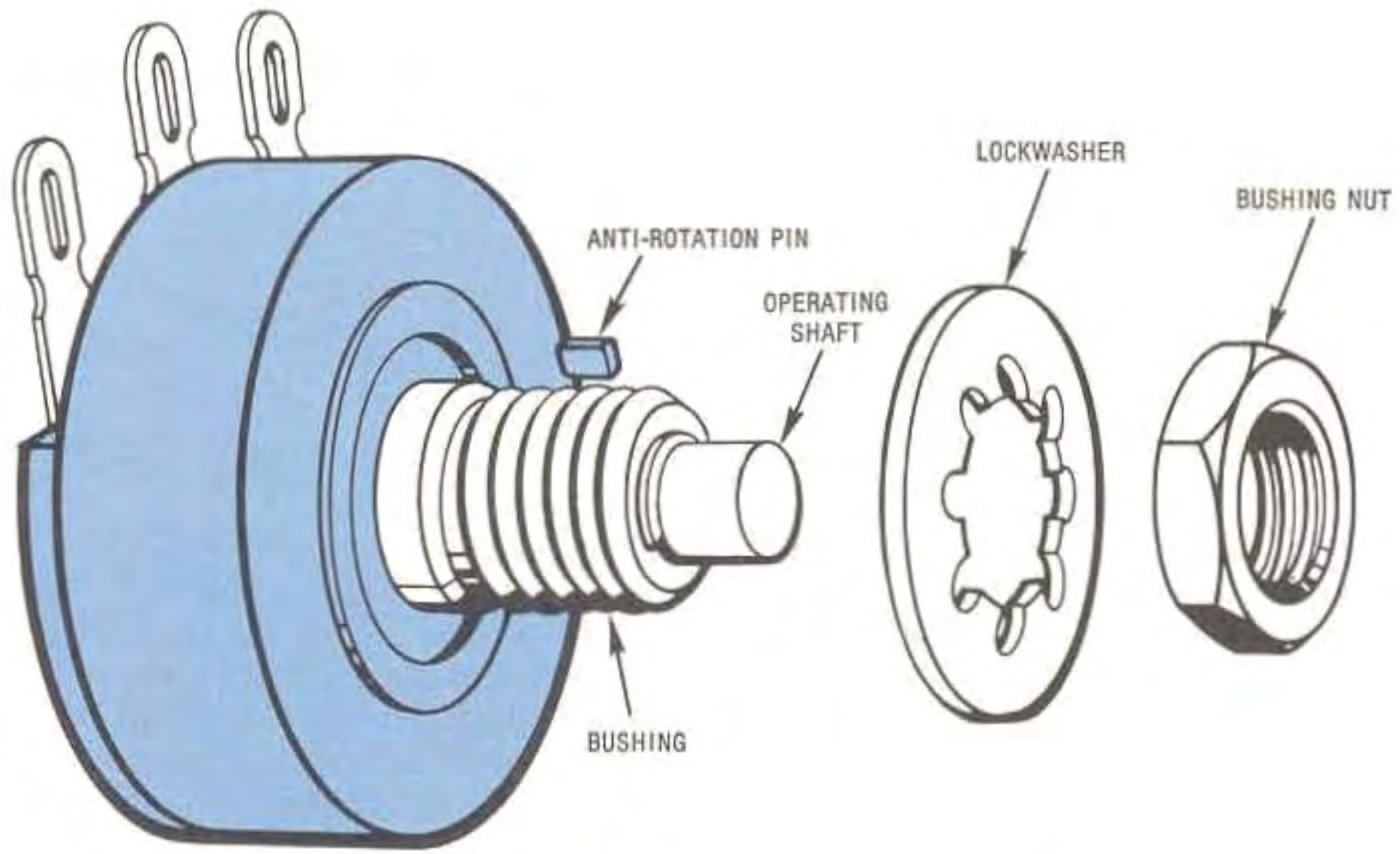

Fig. 8-11 Bushing mount potentiometer



Fig. 8-12 Snap in mounting potentiometer



## STRESSES AND STRAINS

**General.** A few simple precautions in handling and mounting potentiometers can prevent component damage and avoid system problems. Actually, most potentiometers are rugged and reliable, but they do have their limits.

On units with insulated wire leads, hold onto the leads when stripping the ends of the wire. Do not pull directly against the potentiometer terminal and body.

**Trimmers.** The terminal pins may need to be bent at an angle for some particular mounting scheme. Don't just force the lead over by bending it at the potentiometer body. Use a pair of long nosed pliers as shown in Fig. 8-16 to relieve the stresses which might otherwise be induced into the potentiometer.

If a lead is bent in the wrong direction, straighten it out with the pliers and re-bend it correctly. Never twist the pins or solid leads as that might rupture the connection to the element terminations. Twisting also can provide a leakage path in an otherwise sealed unit by breaking the bond between the package material and the wire lead.

Avoid pulling on the leads. Forcing a package to lay down after the pins have been soldered in place can result in an open circuit or an intermittent connection.

**Precision and Controls.** Many precision potentiometers have a small anti-rotation pin on the front surface of the bushing mount package. If the anti-rotation feature is not used, then either remove the pin by clipping or grinding it off, or use a small washer between the potentiometer and the mounting panel. Otherwise, when the nut is tightened down on the bushing, the anti-rotation pin is forced between the potentiometer

and panel with unwanted stresses again introduced.

If wire cables are used to connect to the terminals of the potentiometer, use some form of strain relief to prevent a possible pull on the terminals. A small plastic tie is a good investment.

## SOLDERING PRECAUTIONS

Potentiometers, like most electronic components, are subject to damage if excessive heat is applied to their terminals or housings during installation. When soldering by hand, use only enough heat to properly flow the solder and make a good electrical joint. Continued application of heat from an iron can soften the case material surrounding the terminals. This can make the potentiometer more susceptible to future stresses even though it may not cause immediate failure.

Soldering should be done in a physical attitude such that gravity will help keep any excess solder or flux out of the interior of the potentiometer. Some low-cost potentiometers are susceptible to flux entering along the leads. If it gets on the wiper or element, it may cause an open circuit or at least a very erratic output during adjustment.

Properly performed, wave soldering is usually more gentle than soldering by hand. Improper control of the time and temperature can result in a damaged component as well as a poor solder job. One area which needs special attention is the application of flux. Applied too generously, the flux can enter an unsealed potentiometer with unfortunate results as discussed previously.

In some instances, it may be wise to delay installation of the potentiometers until after wave soldering has been completed. Small solder masks or round toothpicks can be used to keep the circuit board holes open for later installation of potentiometers.

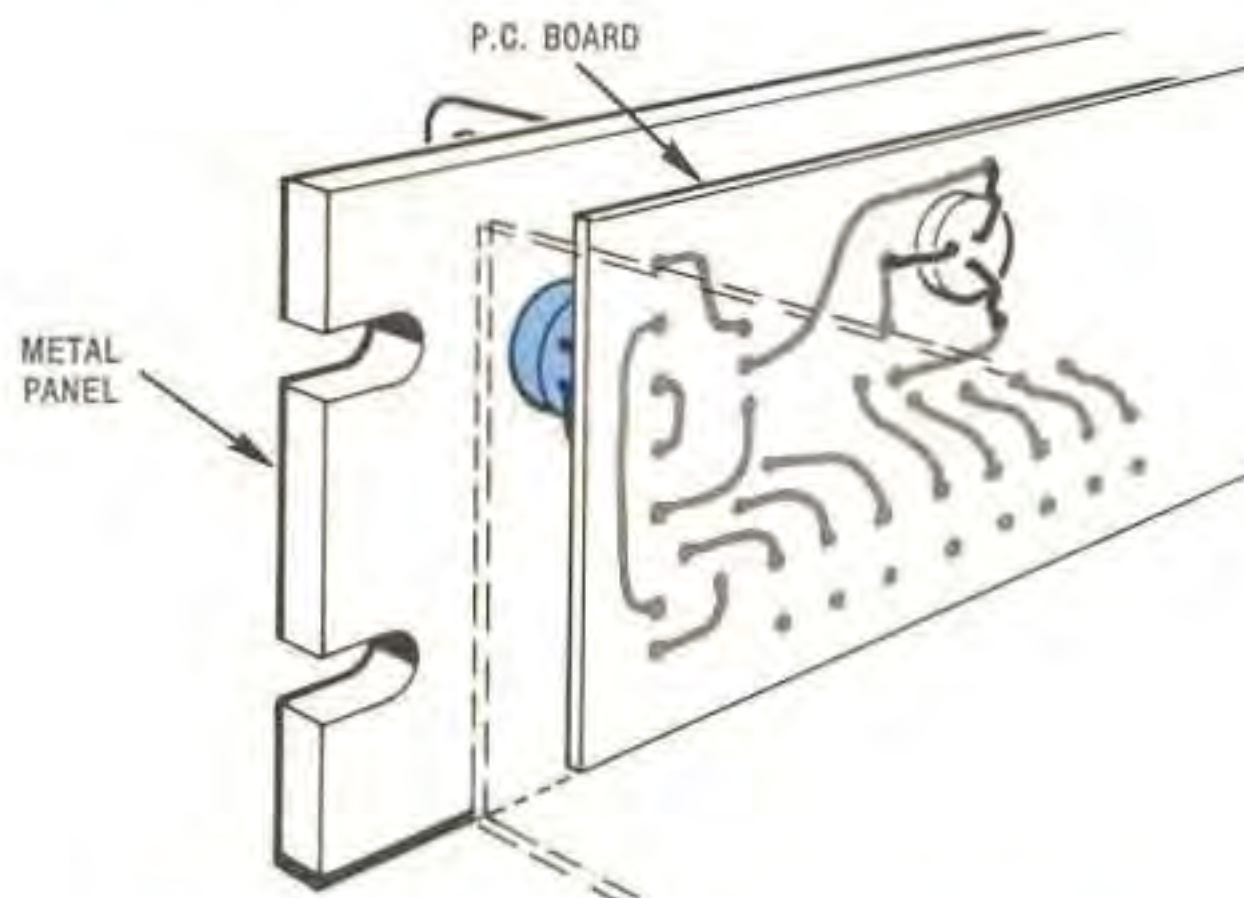

**Fig. 8-13** Printed circuit board simplifies front panel wiring



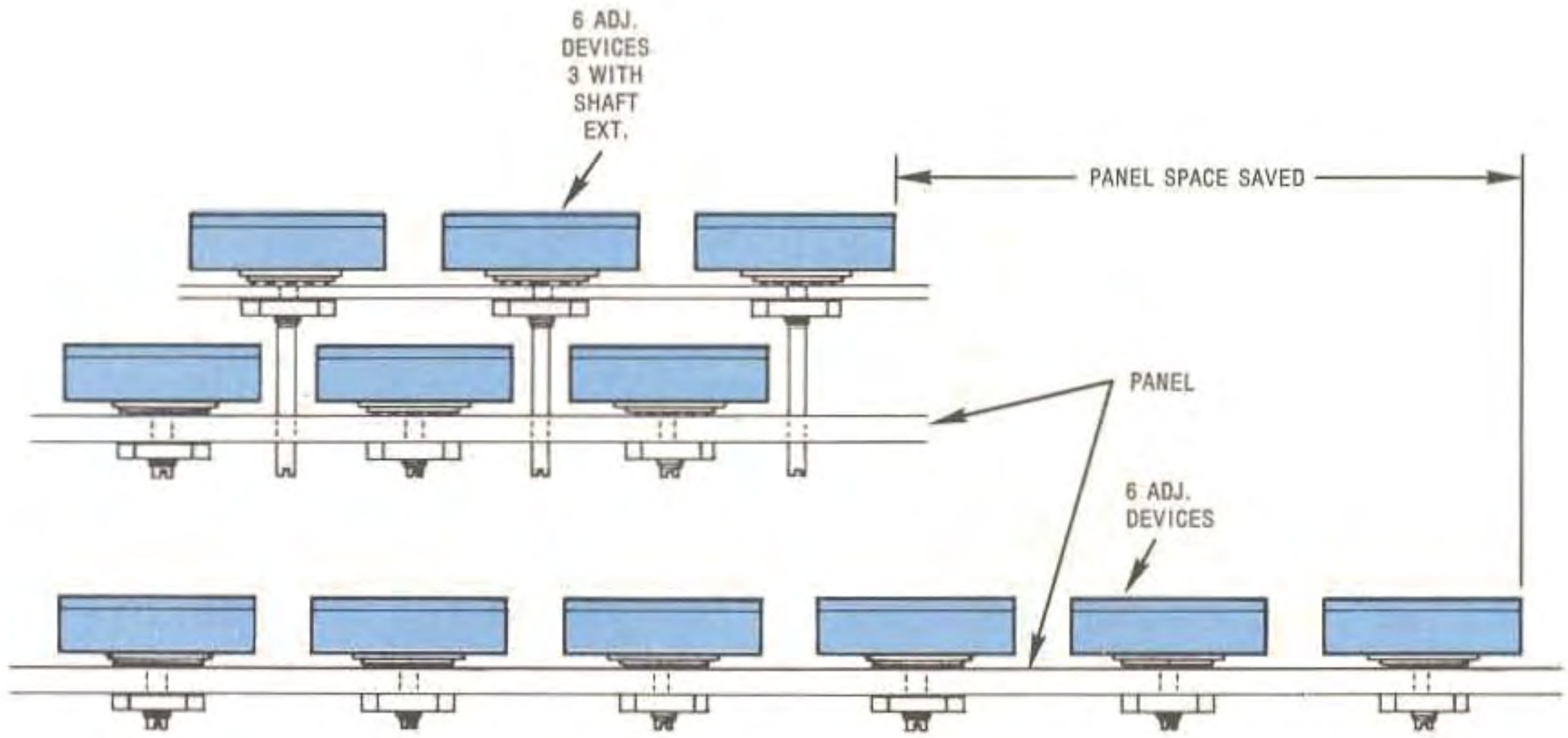
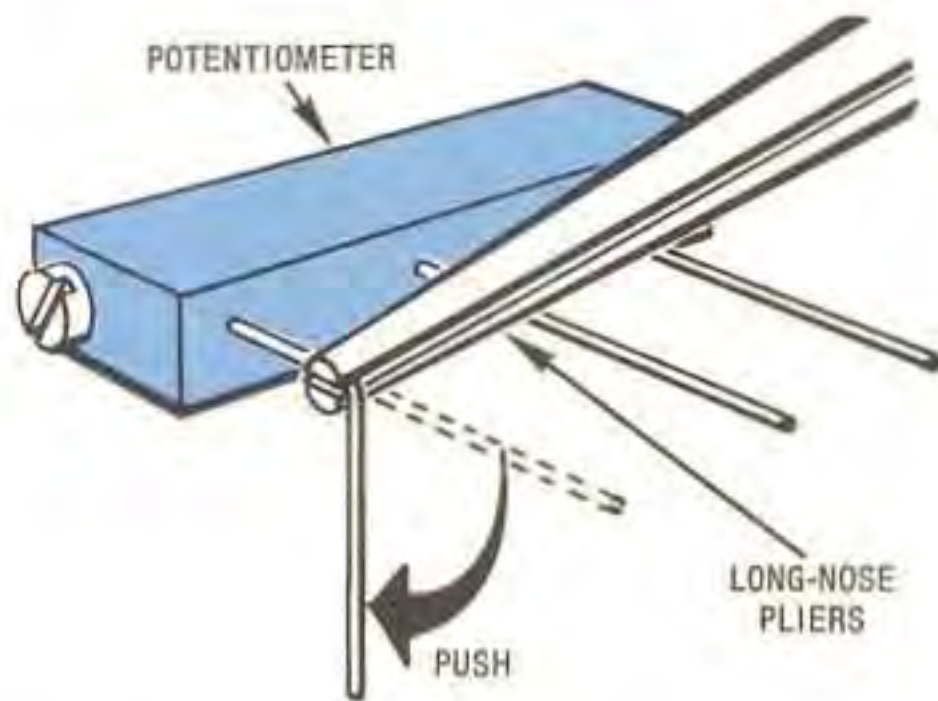

**Fig. 8-14** Shaft extensions allow versatile placement of potentiometers and increased panel packaging density



**Fig. 8-15** Adjustment potentiometer mounting hardware





**Fig. 8-16** To bend leads, hold pliers to avoid stress on the potentiometer

## SOLVENTS

Solvents are frequently used to remove flux residue from printed circuit cards. If the circuit card contains potentiometers, careful selection of the solvent is necessary because certain compounds can be harmful to potentiometers.

Some solvents will attack the plastic housing material or the adhesive used to assemble the unit. Before using any cleaning techniques, consider the potential incompatibilities between the solvent used and *all* components to be subjected to the process.

Where the entire printed circuit card assembly is to be totally immersed in a cleaning solvent, it is possible that some solvent may enter the potentiometer's package. If the solvent contains some dissolved flux (and that's its primary function), then it is possible that flux residue will remain on the element surface after the solvent evaporates. This is sure to cause erratic wiper behavior and noise.

The severity of a solvent on a material is a function of the temperature of the solvent, exposure time, and agitation of the fluid. A great variety of solvents are used in the electronics industry under a multitude of trade names. Experience has shown that for consistent results in cleaning circuit board assemblies, it is wiser to buy solvents by their chemical name. Fig. 8-17 lists several common solvents that are acceptable (or unacceptable) for use with potentiometers. Appropriate precautions, such as venting, should always be observed when handling hazardous fluids.

One solvent that is not recommended for use with potentiometers or other electronic components is the azeotrope of trichlorotrifluoroethane with methylene chloride. Although there are undoubtedly other solvents that might have a bad

effect on potentiometers, this is one of the most common.

If the solvent problems cannot be corrected by using a more gentle procedure or changing fluids, then it may be wise to delay installation of the potentiometers until after the main cleaning is done.

## ENCAPSULATION

In most applications where the potentiometer's function is to provide occasional control or adjustment, it is usually positioned outside any encapsulated section. However, if the potentiometer is only used for adjustment of circuit performance during assembly, then the entire circuit, including the potentiometer, may be potted.

Typical encapsulation procedures use either pressurized encapsulation material or the application of a vacuum to aid in the removal of air bubbles which might produce voids in the coating. It is safer to check with the potentiometer manufacturer for this application. Unless the potentiometer is properly sealed, it is possible for some of the encapsulant to enter the package and cause problems. Although readjusting of the potentiometer is not required (hence, there is no worry about material getting on the element away from the present position of the wiper), it is possible for the potting material to actually lift the wiper off the element. This results in an open circuit for the potentiometer and a rejected circuit board assembly.

One successful technique for avoiding this problem is to apply a somewhat generous coating of a cement to all probable entry points on the exterior of the potentiometer. If the cement is allowed to cure at room conditions, then it can act as a barrier to the normal encapsulant.

### COMMON ACCEPTABLE SOLVENTS

1. Trichlorotrifluoroethane
2. Trichlorotrifluoroethane and isopropyl alcohol
3. Trichlorotrifluoroethane and ethyl alcohol
4. Trichlorotrifluoroethane and acetone
5. Trichloroethylene
6. Perchloroethylene
7. Chloroform
8. 1, 1, 1 trichloroethane
9. Methyl chloroform

### SOLVENTS TO AVOID

1. Azeotrope of trichlorotrifluoroethane with methylene chloride

**Fig. 8-17** Some common solvents





Previous chapters have presented all of the positive things about potentiometers and how to develop cost-effective designs for optimum performance and reliability. This book would be incomplete without introducing KUR KILLAPOT, that mischievous, misdirected character who seems to leave his mark wherever pots are used. As you can tell from his outfit, he's been around at *least* since pots were found under a dinosaur. One historian claims that after the invention of the wheel, KUR was the first to run over somebody! Some long-timers will remember his efforts as a gremlin in World War II. His more successful phenomena are still unexplained.

KUR *intends* to be helpful but when it comes to using pots he's apt to cause problems. For example, he means well but sometimes gets a little heavy handed . . . uses a boulder when a pebble would do . . . or his Cro-Magnon brain doesn't quite grasp some fundamentals like Ohm's law . . . so he tries to make pots do things they can't or shouldn't. He's always around when pots are designed in, specified, installed and in service.

Actually KUR isn't bad but it does seem like sooner or later he screws something up . . . always with the *best* of intentions.

For those who revere pots and always want to use them properly to gain the ultimate in performance, reliability, and cost-effectiveness from these rugged and reliable components, read on: By following KUR's antics, perhaps you'll avoid ways of damaging a potentiometer or a circuit. We ask you to take heed by learning from KUR's mistakes. A summary of how to do this is at the end of the chapter.

All of his twenty-three adventurous mishaps that follow are arranged under these headings:

**MAYHEM**  
MECHANICAL  
ABUSE AND  
MISUSE

**SLAUGHTERING**  
SLAUGHTER BY  
SOLDERING

**ZAP!**  
ELECTRICAL  
ABUSE AND  
MISUSE



# MAYHEM

MECHANICAL  
ABUSE AND  
MISUSE



When KUR takes the direct approach and does his dastardly deed early in the game, he uses the mechanical crunch. Several possibilities will be discussed. Even if he avoids them all, his carelessness is sure to trigger other sure fire ways of inflicting pain, suffering, or death upon potentiometers by MAYHEM — mechanical abuse and misuse.

A small projection, normally called an anti-rotation pin, is provided on the face of bushing mounted precision potentiometers and on many industrial types of controls. Its *intended* function is to keep the potentiometer body from turning after installation on a panel or bracket. This requires an extra hole be drilled or punched in the panel to receive it. If KUR forgets to drill this mating hole and jams the pin right against the panel he can produce the proper conditions for a strain in the case. After KUR's JAM SESSION, the adjustment shaft will be out of square with the panel so it will look a little strange by today's standards. This may not produce an immediate fracture of the potentiometer body. The unequal stress generated will be sure to cause some effect in eons to come, even if it is only a loss in linearity or increased rotational torque (better known as a bind). If KUR is not careful, a delayed failure will occur in the field. This will get him out of his cave and among the saber-toothed tigers which may be hazardous to his health.

This situation can be made even worse. Greater strain and degradation may occur in time when the pot is mismounted near some source of heat, for example, the pot placed close to a really hot power resistor or lossy (technical term meaning dissipating more heat than usual) transformer. Excessive internal power dissipation can also give the same bad results.

## JAM SESSION

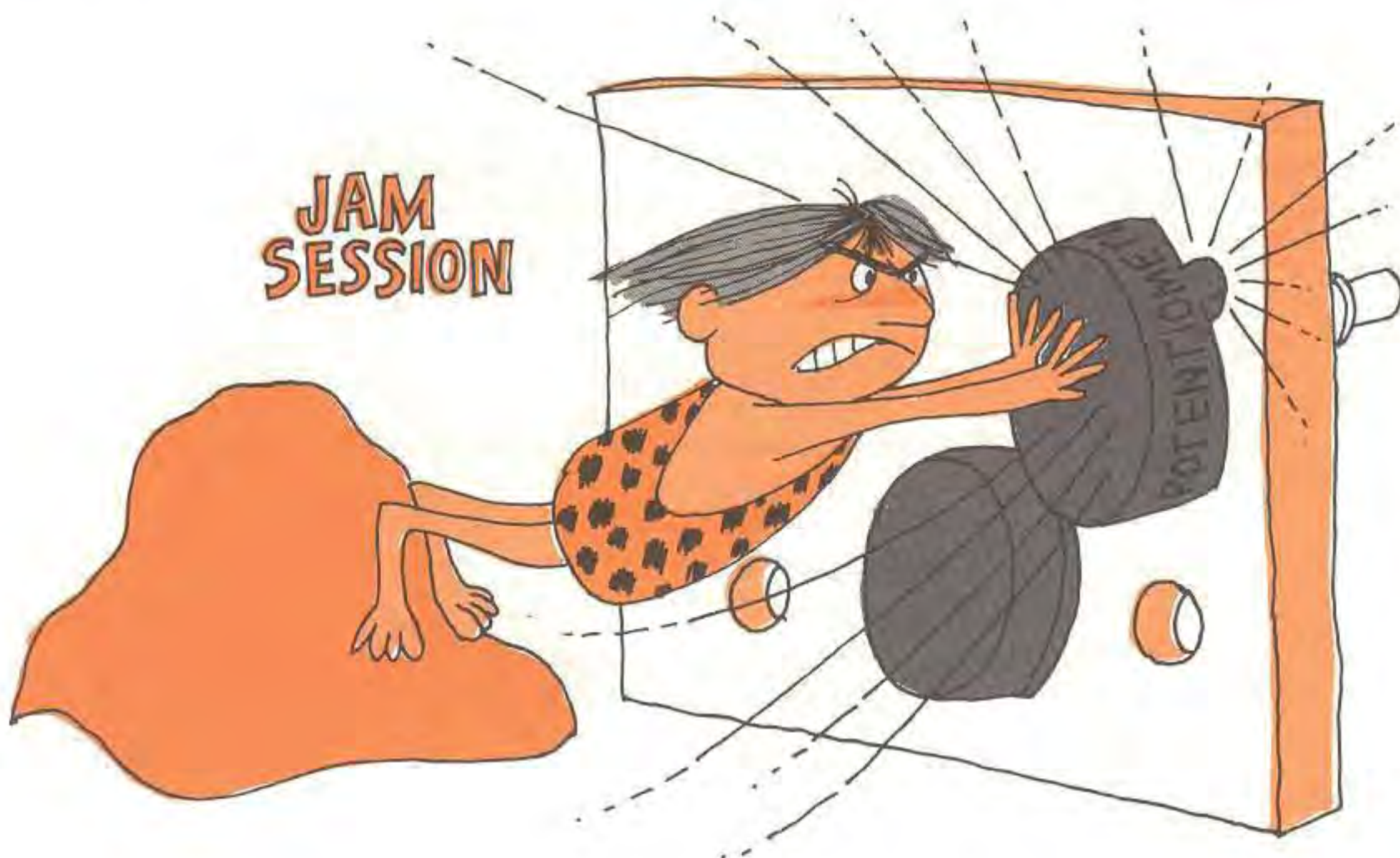





### SAVE A NUT AND BOLT

Another ineptitude which will produce almost the same effect is the use of the potentiometer to clamp a bracket or a subpanel to SAVE A NUT AND BOLT. If the assembly is thick enough so the threaded bushing barely extends beyond it, KUR gets instant failure by tightening the bushing nuts down very tight on a thread or two. On the other hand, a delayed failure is most likely if he uses only light tightening. In this way things will loosen later and result in a few surprises . . . such as loose panels and components.

KUR has found that unless the potentiometer case is completely destroyed, it will still continue to function as a clamp — long after it stops functioning as a potentiometer.

### Versatile Cable Clamp

KUR tries to save money and be creative. He has discovered that a rectangular trimmer mounted to a panel or printed circuit card by means of screws make a VERSATILE CABLE CLAMP. Unfortunately, this provides an almost fail-safe means of failure with several disastrous modes.

Worse results are obtained when the cable is bunched up near the center of the pot to give maximum stress. KUR learned he can get instant failure or a more subtle long-term effect depending on the torque on the screws.

### VERSATILE CABLE CLAMP





## THE SQUEEZE PLAY



When stacking several trimmer potentiometers together with mounting hardware, KUR wants to be sure they are *really* tight. In his overzealous urge to do things right he sometimes does 'em wrong. This is one of those times! Using the SQUEEZE PLAY he overtightened the screws, thereby squeezing the potentiometers to death. Won't he ever learn?

Another way KUR inflicts punishment on a pot is by pulling hard on its solid terminals or flexible wire leads in a TUG O' WAR during installation or after wiring is complete. It takes *cave man* forces on some terminals to pull them out by the roots. KUR didn't uproot them, but did cause a simple internal open connection that was not obvious even to the experienced eye. Excessive pull on the terminals can cause an intermittent connection, which may not show up until after the system is shipped out of the cave and into the field.

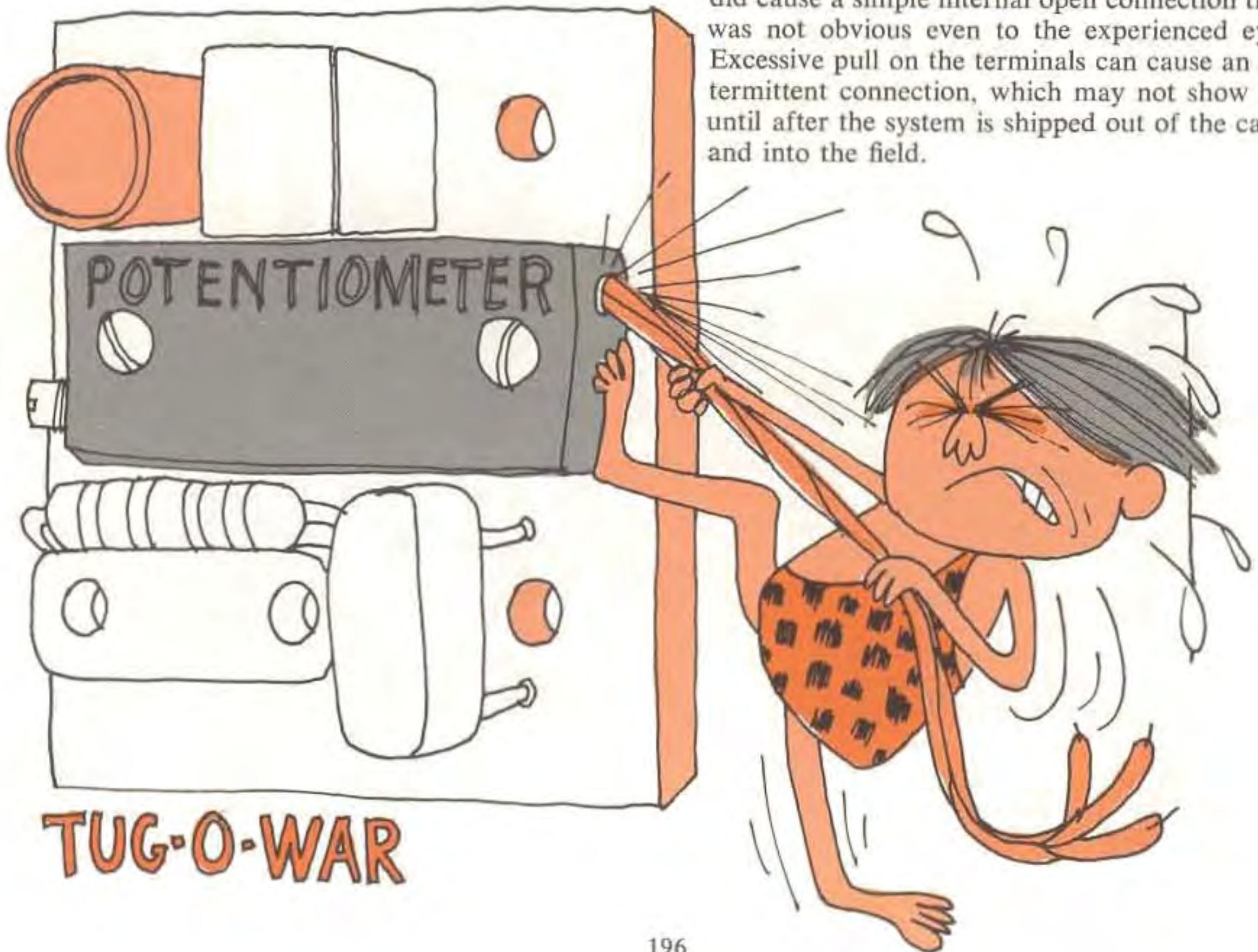

## TUG-O-WAR



## DOING THE TWIST



As a general rule, potentiometers are not contortionists. KUR has wrecked quite a few of them by forcing them into **DOING THE TWIST**. This is most easily done on trimmers with wire pin terminals. First, he bends the lead over in the wrong direction; then he grasps the lead with a pair of pliers and roughly twists it around to the direction he wanted all along. Once in a while he may overtwist a terminal so it will have to be twisted back again, causing *more* strain.

This action will sometimes produce instant failure, but more often it causes an intermittent connection. Even with experience, KUR never has been able to determine the way to bend terminals right the first time.



## THE BIG KNOB

KUR wants to be helpful so helps out by dragging in the biggest **BIG KNOB** he can find to put on a pot . . . a *small* potentiometer. The larger the knob the higher the torque the unsuspecting user can easily apply. A pot with low stop strength is very apt to be an innocent victim of this poor choice.



Another clever idea from KUR's caveman brain that he applies in his eagerness to finish an assembly or get it repaired quickly is to use a panel mounted precision potentiometer as a **HANDY HANDLE** to pick up an entire assembly. Wrestling with a heavy chassis in this way can damage the potentiometer by bending the bushing or breaking or cracking the housing. This rough treatment might even bend a panel, so hopefully he'll remember potentiometers are *not* handy handles.

## HANDY HANDLE



## TIPOVER TERROR

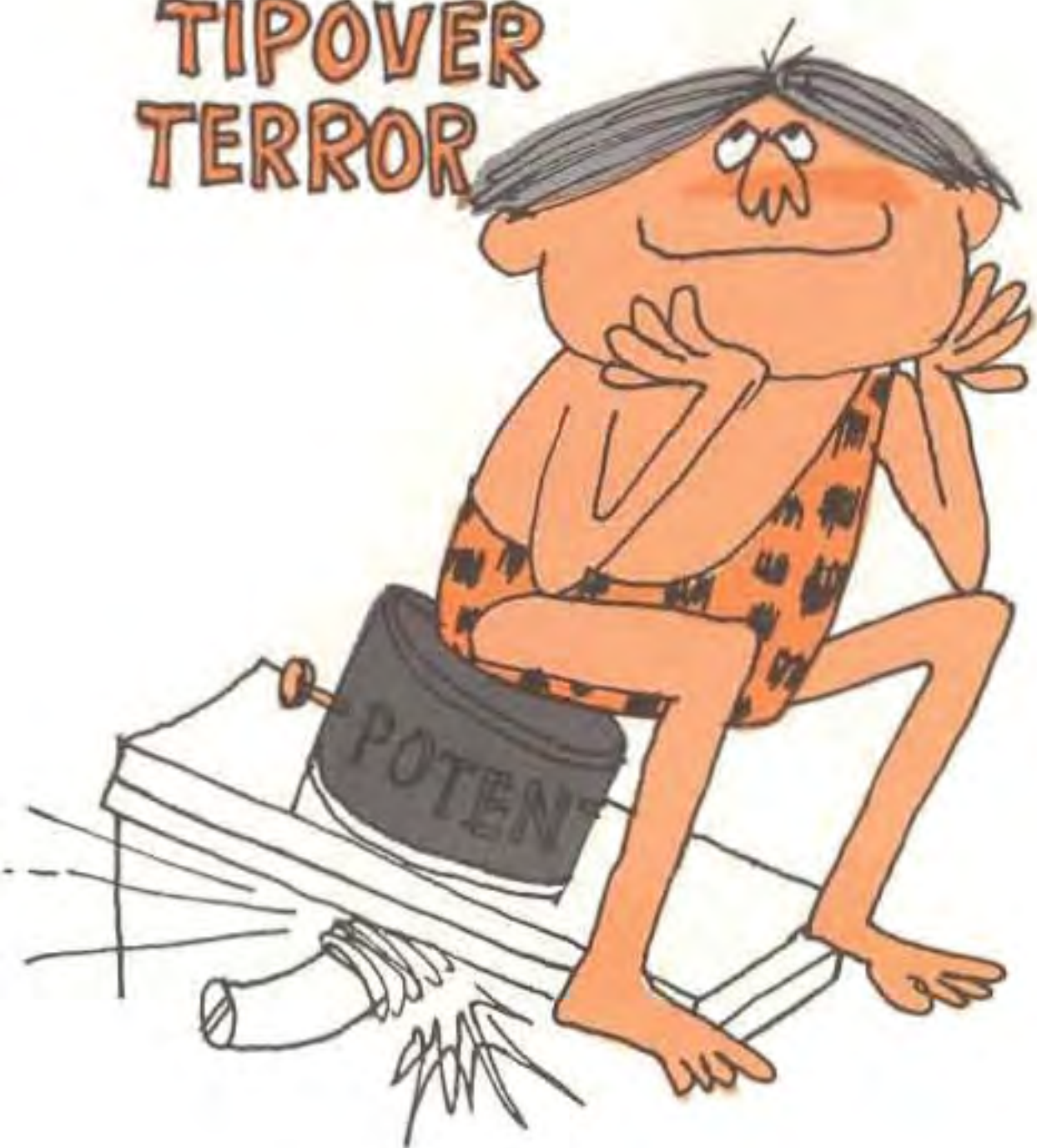

Another disaster KUR learned the hard way is **TIPOVER TERROR** . . . accomplished by laying a chassis or cabinet on its face with the extending potentiometer shafts supporting most of the weight. This puts an axial or radial load on the shafts that may exceed the limits, especially if the chassis is dropped against a workbench or stepped on by a mastodon. The result may be a bent shaft, damaged bearing, or loosening of the rear cover of the potentiometer.



**SLAUGHDERING**  
SLAUGHTER BY  
SOLDERING



Since KUR just discovered fire, he's still in the dark about sophisticated soldering techniques and gets burned with his SLAUGHDERING — slaughter by soldering.

**IT TAKES TIME**

KUR is conscientious and wants to be thoroughly thorough and believes IT TAKES TIME to do it right. This is great in most cases but not when he does it with soldering. For example, a terminal may be heated adequately for soldering almost instantly but he takes his time. Heat gets inside the potentiometer where it can damage the terminations or cause a shift in the resistance value. He even slowed down the travel rate through his wave soldering pot until he got wise.

**HOTTER' N' HOT**



Until he learned better KUR always liked to solder with a big soldering iron or turn up the bonfire on his solder flow pot to get things HOTTER N' HOT. He thought this would improve his solder joints and speed up the process. Instead, excess heat can soften material surrounding the terminals so that it will be more vulnerable to damage with a quick pull or twist. In extreme cases, the heat may penetrate the potentiometer and cause an internal joint failure or mechanical problem.





When it comes to preparing for soldering, KUR wanted to be ready. He figured if a drop of flux is good a flood would be better. FLUX IT AGAIN was his motto. He was an expert at flux flooding until he found that noisy contacts or even intermittent opens can be caused by too much flux. Actually it's hardly ever a problem on sealed potentiometers but KUR still hasn't learned to economize by using less flux. He would find this takes less clean up time too.

## SOLVENT SOAK



KUR is the biggest SOLVENT SOAK around especially when he uses too much flux. He doesn't choose his solvent with care to be sure it's adequate but not too severe. If he only read Chapter 8 to pick up techniques and solvents to do his particular job, he could get rid of his old solvent soak image.

## FLUX IT AGAIN

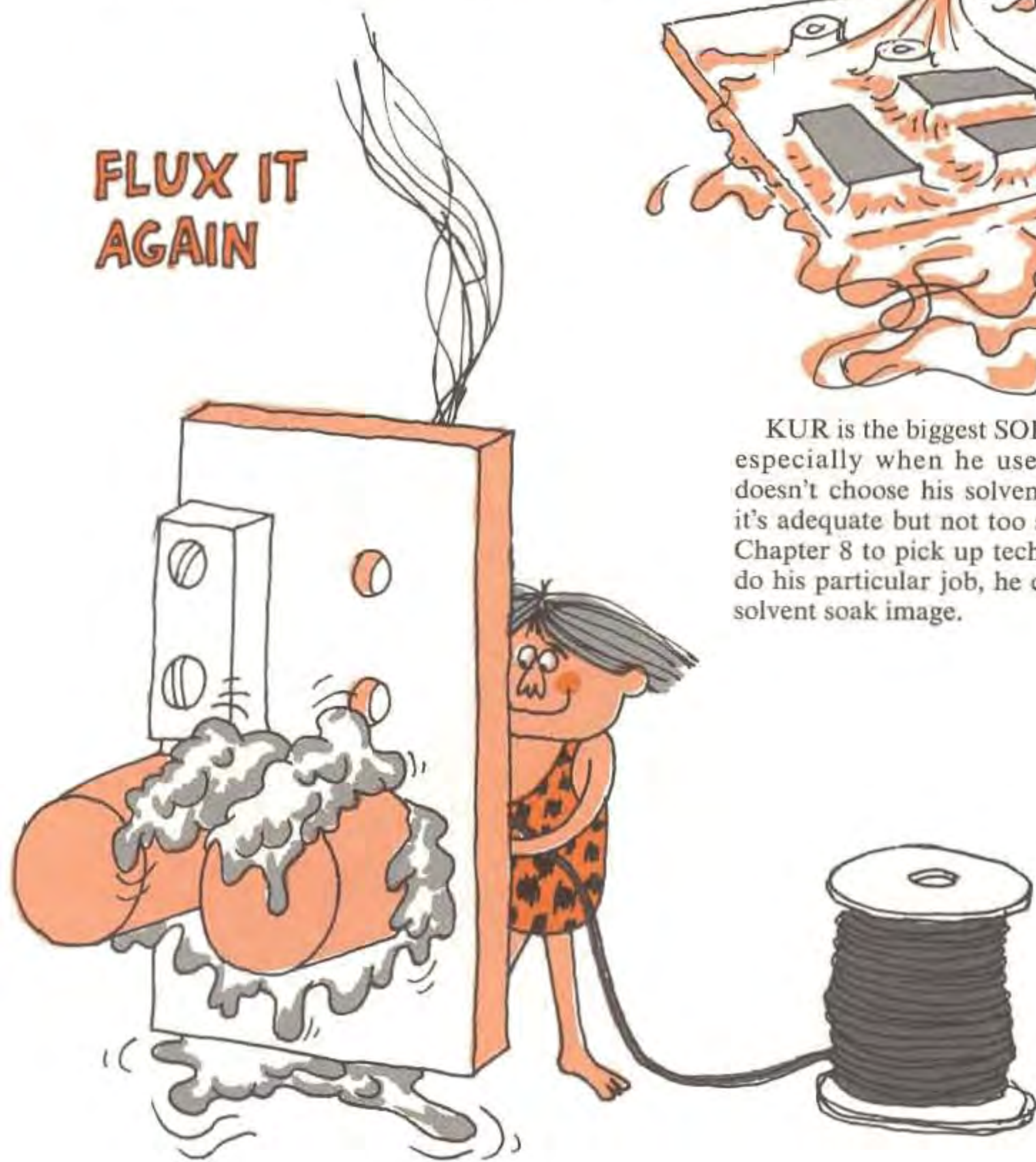



**ZAP!**  
ELECTRICAL  
ABUSE AND MISUSE

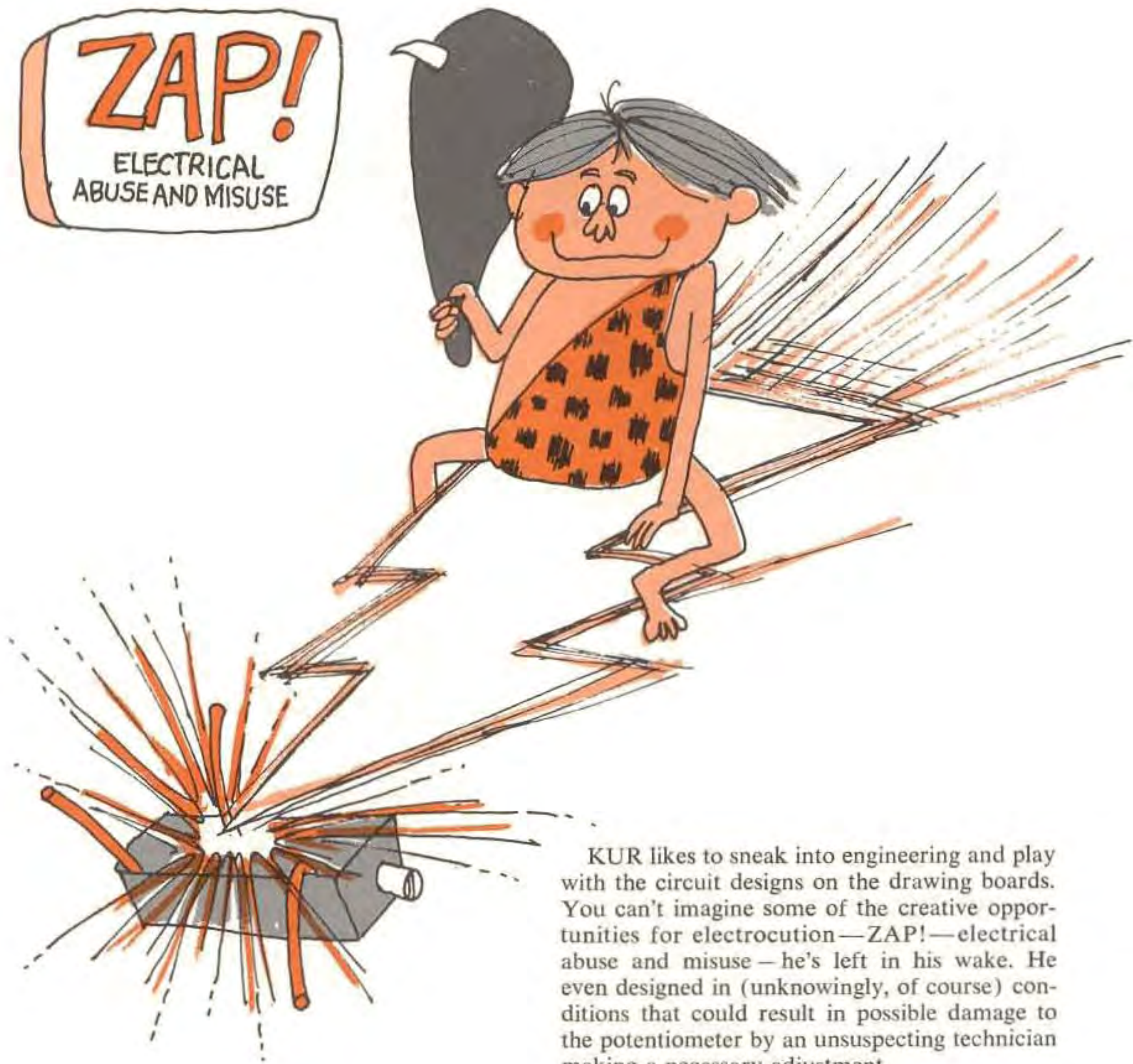

KUR likes to sneak into engineering and play with the circuit designs on the drawing boards. You can't imagine some of the creative opportunities for electrocution—ZAP!—electrical abuse and misuse—he's left in his wake. He even designed in (unknowingly, of course) conditions that could result in possible damage to the potentiometer by an unsuspecting technician making a necessary adjustment.

Thinking he was planning ahead, he set the stage for multiple component failure or domino effect where the death of some other component takes the potentiometer with it.

KUR found too late that he could zap a pot faster than saying saber-toothed tiger with one of three simple methods: Exceed the power rating of the element, cause excessive wiper current flow, or operate the unit at a very high voltage which can cause voltage breakdown between the element and a grounded case or bushing. Any of these methods can be quite disastrous but KUR hasn't figured them out yet. He wants to warn you with a few basic illustrations that KUR still can't fully comprehend.



## MORE POWER TO THE POT



Causing the potentiometer to dissipate power in excess of its rating will produce internal temperatures that will really warm things up! In fact with **MORE POWER TO THE POT** it may get that warm glow deep inside. This can produce a direct failure of varnishes and other insulating materials, or might be enough heat to cause a deformation of the element or surrounding parts.

Heat combined with some form of mechanical strain as discussed earlier in this chapter can cause trouble. High enough heat can soften the plastic used for the body and housing allowing movement of various parts that release the strain.

Remember, from Chapter 2, the power rating of a potentiometer is somewhat dependent upon the manner in which it is used. Thus, excessive current in only a portion of the element might easily exceed the power rating.

Damage due to excess concentrated power is likely when several potentiometers each dissipating full rated power are mounted close together. KUR watches for this condition but forgets to derate the power accordingly.



KUR's earliest killing of a potentiometer, the **CHECK-OUT BURN-OUT**, was at incoming inspection when he used a common VOM multi-meter to measure end resistance or just to look at the output of the potentiometer. He set the meter to the  $\times 1$  resistance range with one lead connected to the wiper and the other to one end of the element; then, he turned the shaft until the meter read minimum resistance. As luck would have it, the power source in the VOM caused a wiper current of 300 to 400 milliamperes! This either destroyed the potentiometer right on the spot or at least burned some rough spots on the element. KUR still doesn't know that a VOM plus a POT equals a NO-NO. Of course, he hasn't learned to use a digital ohmmeter either.

## CHECK-OUT BURN-OUT





## UP THE WIPER CURRENT

Of all the electrical techniques for potentiometer execution, KUR has been burned on UP THE WIPER CURRENT most often. Maybe it's because it's too subtle for his stone-age mind. Cermet and plastic film potentiometers are especially easy to damage with too much wiper current. Excessive noise and rough adjustment can be current induced even though the unit doesn't fail completely. Still KUR keeps designing in excessive current loads that wipe out wipers and fry elements in a flash. In fact, some of his prehistoric circuits are still in use today.

## ZAP IT LATER

KUR carelessly designed the ZAP IT LATER, Method A Circuit in which execution of a potentiometer might be performed during final checkout or even some time after the equipment has been in service.

This circuit is one for delivering a constant current to the load. A VR diode is used to establish a constant voltage from the base of the transistor to the positive supply. The emitter current, and hence the collector current flowing through the load, will be determined by the difference in the VR diode voltage and the base-emitter voltage of the transistor in conjunction with the value of the potentiometer resistance.

KUR's instructions for initial adjustment (chisled in stone, of course) had the potentiometer set to maximum resistance. Then, while monitoring the current level, he adjusted the potentiometer for the proper output current. This will defer execution until a technician in the field unsuspectingly turns the potentiometer too far clockwise and exceeds the current rating of the potentiometer. The excess current might also zap the transistor and even damage the load too, which results in a difficult repair job.

KUR should learn from this experience that by placing a fixed resistor in series with the potentiometer to limit the minimum total emitter resistance he can avoid this problem entirely.





KUR's ZAP IT LATER circuit, Method B, designed in 1,000,000 B.C., causes delayed execution. It provides an indication of charge completion by monitoring the voltage across the battery. Potentiometer  $R_1$  permits an adjustment of the threshold voltage at which the lamp is turned on.

If the wiper of the potentiometer is turned full clockwise, a large current will flow through the VR diode, the wiper, and into the base of the transistor. If KUR's design is really poor he can be sure of slaying the potentiometer before the VR diode or transistor open up. On the other hand, if the VR diode shorts out, then he can almost be assured that the pot and transistor will be destroyed too. Once again, although KUR provides careful instructions to the person making the initial adjustments, an unsuspecting technician in the field was stuck with the dirty work and zapped the potentiometer.

Still another of KUR's infamous circuits, ZAP IT LATER, Method C, has a potential for maiming. This is a very simple unijunction oscillator in which the potentiometer is used to vary the charging rate of the timing capacitor and hence the operating frequency. The lower the resistance, the faster the charging rate and the higher the frequency.

KUR provided a control knob adjustment like this and didn't have to wait long for some one to turn it all the way. Suddenly the oscillator stopped! A conflict occurred between the potentiometer with minimum resistance trying to charge the capacitor and the unijunction transistor trying to discharge it. High currents resulted, and as luck would have it, the potentiometer, the unijunction, and the output pulse transformer were wiped out. One, two, three! Zap! Zap! Zap!

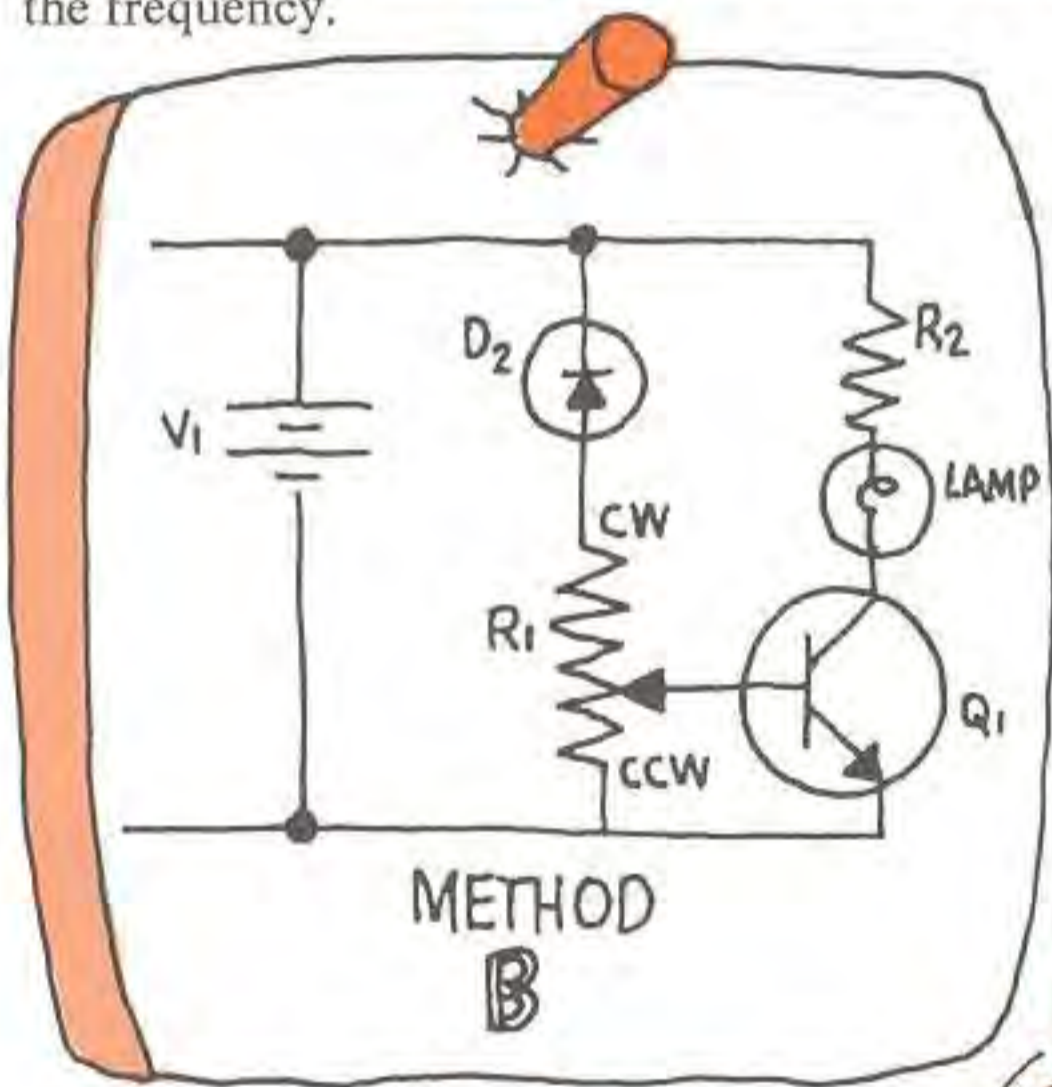
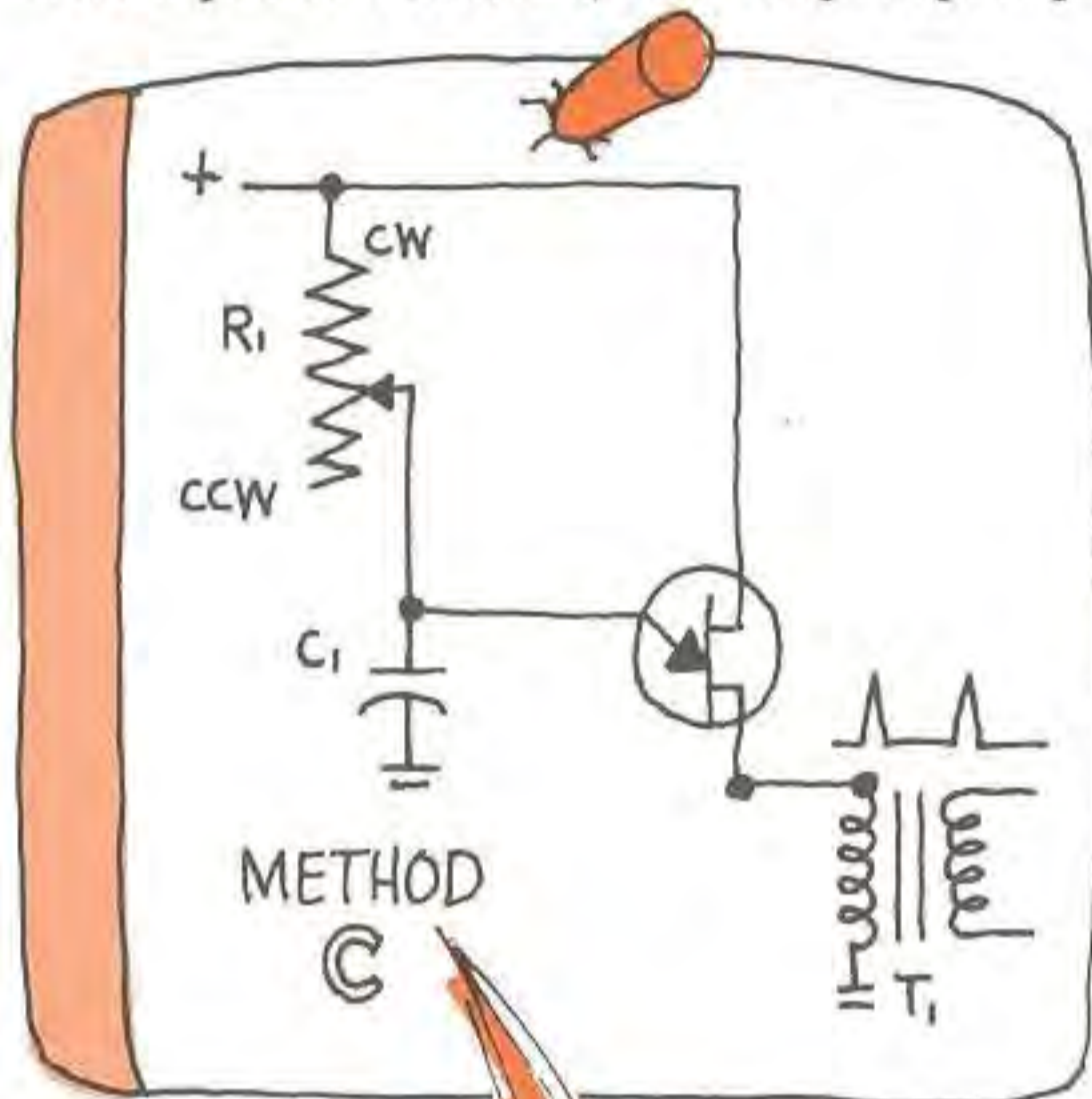

**ZAP IT  
LATER**

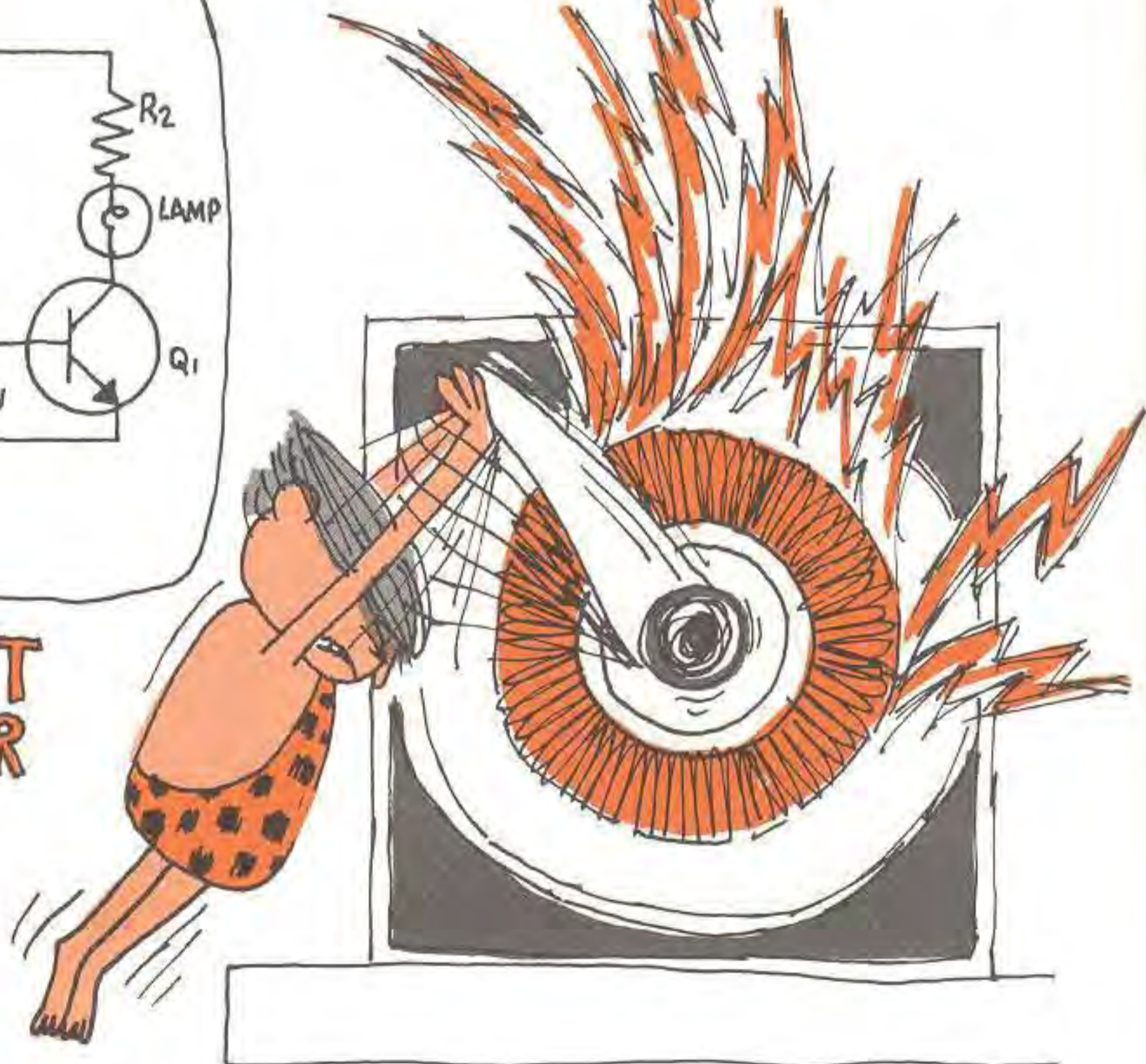



In the previous circuit arrangements, failure was induced by adjustment. In some applications, KUR caused a failure in a delayed manner during normal operation without the need for *any* adjustment. **CIRCUIT SURPRISE** is a good example. Here the potentiometer is used to generate a sawtooth output voltage waveform, or perhaps the setup is used to produce an output voltage indicative of the shaft position. A capacitor reduces the noise. Note that the output voltage must change from a zero value to a maximum as the wiper reaches the counterclockwise end of the element. This sudden change in voltage causes a high pulse current through the capacitor. After a while, it is quite probable that either a portion of the element will be eroded away or the wiper will become damaged by the high pulse currents. Erratic output will soon be followed by complete failure.

In some of the previous circuits, you saw how KUR managed to set up the massacre of several components with one stroke of the pencil on the drawing board. This is often called the domino effect. It is possible to design a circuit which will perform well as long as all components are good, then set up the domino game after one part fails due to some other cause.

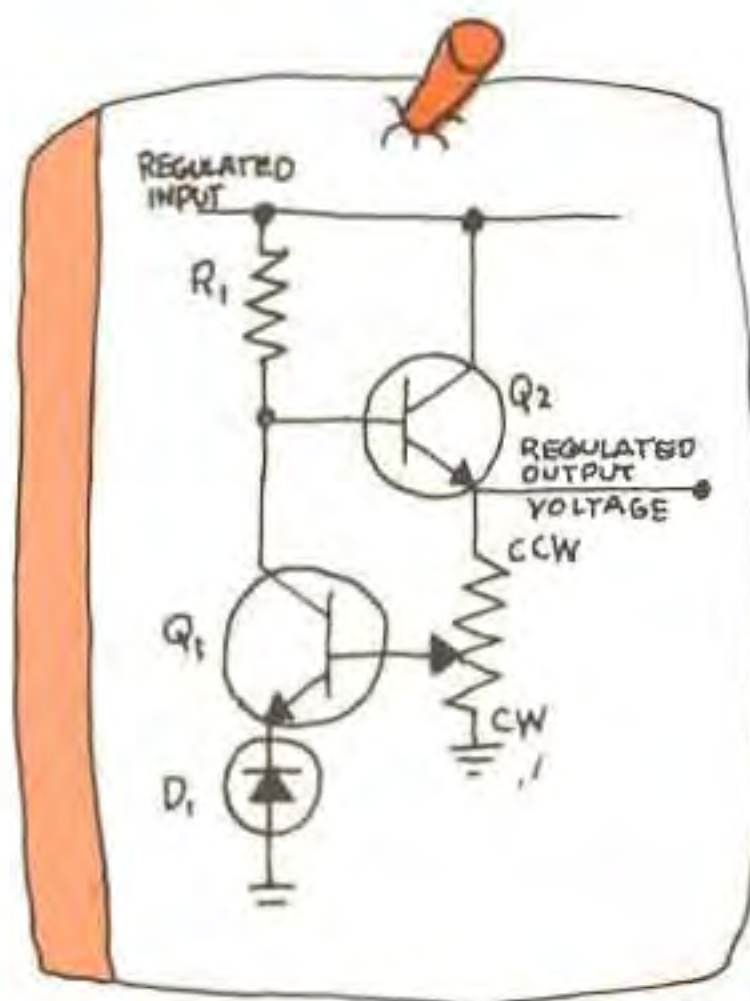

**ZAPPO!**



Study the ZAPPO circuit above for a simple voltage regulator. As long as all of the parts are good, the position of the potentiometer can be varied over its entire range without causing damage. Minimum output voltage is achieved with the wiper at the counterclockwise position, and maximum voltage (with no regulation either) results when the wiper is moved to the extreme clockwise position.

Consider what might happen if transistor  $Q_2$  were to fail by shorting. The output voltage would jump to the maximum. KUR, noting this, might first try to reduce the output voltage by adjusting the potentiometer. He turns the potentiometer counterclockwise; the wiper reaches the end, and zappo! He wipes out the potentiometer, transistor  $Q_1$ , and the VR diode.

**CIRCUIT SURPRISE**

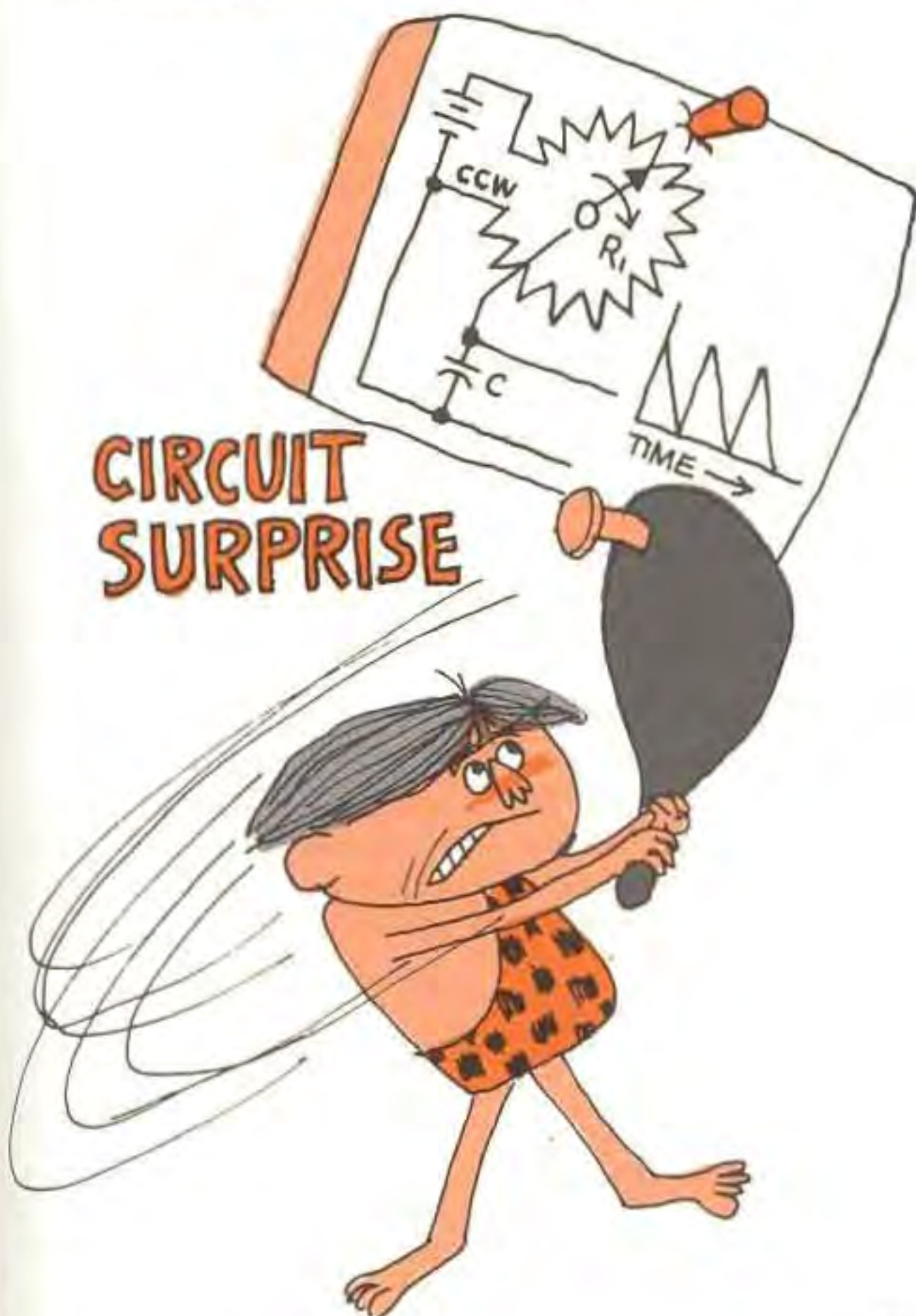



Another of KUR's circuit arrangements which looks perfectly acceptable chiseled in stone but relies on the laws of probability, is called **SHORT STUFF**. Here a control voltage is developed by the potentiometer used as a variable voltage divider. The voltage is then transmitted over a cable to some remote point where the current load may be very insignificant. So far, no problem.

Ah, but where you have an external cable leading from one area to another, you have the opportunity for a short. Consider what might happen if the wires in the cable become shorted to each other or even if the "hot" line gets shorted to ground. KUR cranks the potentiometer control knob clockwise trying to get more output. Once again, another pot fatality.

## SHORT STUFF



## HIGH VOLTAGE SURPRISE



Occasionally, KUR has an opportunity to use a potentiometer in a circuit which operates at a high voltage with respect to ground and results in a **HIGH VOLTAGE SURPRISE**. By using a potentiometer with a grounded metal bushing, the full voltage is applied between the element and the bushing frame. This might lead to direct voltage breakdown if the voltage difference is great enough or erratic behavior and possible long-term failure as arcing eats away at the element.

Once (just once!) KUR insulated a bushing mounted potentiometer properly, then an unsuspecting technician came along to make an adjustment using the bare metal shaft . . . high voltage surprise through the technician between the metal shaft and ground! Who was the most surprised? KUR, because he was the technician!

Seriously now, we hope KUR's adventures, while damaging or completely destroying several potentiometers and a few circuits, have been constructive. A summary of how to avoid these problems is on the next two pages. This story was told so you potentiometer users will be more aware of some of the problems that can be induced by misapplication or carelessness.

Potentiometers are inherently very rugged and reliable. With reasonable care in installation and use they effectively perform their function. When correctly applied in a circuit, they are one of industry's most cost-effective components.



## TO GET BEST RESULTS AND MAKE POTENTIOMETERS IMMORTAL

APPLIES TO	PAGE	TO AVOID	DO
ALL POTENTIOMETERS	195	Inoperative or damaged potentiometers.	Mount on flat surfaces. Tighten screws or nuts with reasonable torque.
	196	Open or intermittent terminations and damaged terminals.	Never pull on terminals and leads with excessive force.
	200	Possible damage or degradation from excess and severe solvent.	Use sparingly and never soak components any longer than necessary.
	202	Failure of varnishes and other insulating materials, deformation of element or surrounding parts, softening of plastic and possible shifting of various parts to release internal strain.	Operate potentiometer within power ratings. Watch for overpowering a portion of element.
	203	Noise and rough adjustment, with possible damage to the element.	Operate wiper at current levels within specified values.
	202	Burned out or damaged element due to excess current.	Never use a common VOM (multimeter) to measure end resistance or monitor potentiometer output. Use a digital ohmmeter instead.
	203	Excess current in the wiper circuit.	Place a fixed resistor in series with the potentiometer to limit current.
	204	Damage to potentiometers and other components.	Never design circuits that allow excess power or current to flow through the potentiometer element or wiper circuit.
	204	Burning out potentiometers, unijunctions, output pulse transformers and other components.	Never design circuits that allow potentiometer adjustment settings that will cause excess current through any part of the circuit.
	205	High pulse currents through the wiper.	Design circuits that limit current through the system.
205	Damage to potentiometer and other components.	Design circuits that prevent failure of other components when any component fails.	
RECTANGULAR OR SQUARE, SCREW MOUNTED TRIMMERS	195	Inoperative or damaged potentiometers.	Use cable clamps instead of trimmers to secure cables.



## TO GET BEST RESULTS AND MAKE POTENTIOMETERS IMMORTAL (CONTINUED)

APPLIES TO	PAGE	TO AVOID	DO
POTENTIOMETERS WITH PIN TERMINALS	197	Damaged terminals and potential open connection.	Reform pins with care. Never overbend and reform or twist any terminal excessively.
POTENTIOMETERS WITH SOLDERED TERMINALS	199	Softening material around terminals and failure or damage to internal joints or mechanical problems.	Apply only enough heat to make good solder joint. Use travel rate through wave soldering to accomplish good solder joint and avoid excessive heat.
	200	Noisy contacts or intermittent contacts.	Economize by using only sufficient flux to make a good solder joint.
PANEL MOUNTED POTENTIOMETERS WITH THREADED BUSHINGS		<p>Damaged housing, increased rotational torque, loss of linearity, shaft out of square, general degradation because of anti-rotation pin without matching hole in panel.</p> <p>Stripped threads, loose potentiometers and assemblies.</p> <p>Damage to the mechanical stop of a potentiometer with knob.</p> <p>Bent bushings, broken or cracked housings, and bent panels and bent shafts.</p>	<p>Provide matching hole in panel for anti-rotational pin, or cut pin off.</p> <p>Use threaded bushing long enough for full thread engagement in nut. Use nuts and bolts to fasten other parts together.</p> <p>Use a reasonable size knob to operate the potentiometers.</p> <p>Never lay chassis or panel on its face with potentiometer shafts supporting the weight of the system. Block up the panel to protect extended shafts. Never use potentiometer to pick up chassis or circuit board.</p>
POTENTIOMETERS IN CIRCUITS WITH REMOTE CABLE OR LEADS	206	Damage to circuit or components.	Design circuit to limit current and voltage if cable or lead shorts to ground.



## APPENDICES



- I. STANDARDS OF THE VARIABLE RESISTIVE COMPONENTS INSTITUTE
- II. MILITARY SPECIFICATIONS
- III. BIBLIOGRAPHY OF FURTHER READING
- IV. METRIC CONVERSION TABLE
- V. ABBREVIATIONS AND MATHEMATICAL SYMBOLS



# Appendix I.

## Standards of the Variable Resistive Components Institute

VRCI (Variable Resistance Components Institute) is now known as VECI (Variable Electronic Components Institute).



**The Link to the VECI Standards below is provided for the convenience of the user.**

<http://www.veci-vrci.com/standards.htm>

<u>VRCI-P-100A</u>	<b>Wirewound and Non-wirewound Precision Potentiometers</b>
<u>VRCI-T-110B</u>	<b>Wirewound and Non-wirewound Trimming Potentiometers</b>
<u>VRCI-C-120</u>	<b>Wirewound and Non-wirewound Industrial Grade Panel Potentiometers</b>
<u>VRCI-S-400</u>	<b>Potentiometer Mounted Switches</b>
<u>VRCI-SMT-300</u>	<b>Surface Mount, Sealed, 5MM Square Single-turn Trimming Potentiometer Mechanical Outlines and Land Patterns</b>
<u>VRCI-SMT-400</u>	<b>Surface mount, Sealed, 3MM Single-turn Trimming Potentiometer Mechanical Outlines and Land Patterns</b>
<u>VRCI-SMT-600</u>	<b>Surface Mount, Sealed, 6MM Square (1/4") Multi-turn Trimming Potentiometer Mechanical Outlines and Land Patterns</b>
<u>VRCI-SMT-800</u>	<b>Surface Mount, Sealed, 4MM Square Multi-turn Trimming Potentiometer Mechanical Outlines and Land Patterns</b>



## Appendix II. Military Specifications

Various potentiometers are described by military specifications. In most cases, potentiometers qualified to these specifications are available from several manufacturers. These specifications are used by non-military as well as military users because they are often a convenient standard or reference. Some component or standards engineers modify or use complete sections of military specifications in establishing their own potentiometer requirements.

Since these specifications are revised from time to time we have included only the links to them below.

The specifications, standards and handbooks are found on the DSCC (Defence Supply Center Columbus) web site along with many other related documents.

DSCC Home page. <http://www.dsccl.dla.mil/>

<b>Specifications.</b>	<b>Basic Type</b>	<b>Description</b>
Mil-PRF-12934 <a href="http://www.dsccl.dla.mil/Programs/MilSpec/ListDocs.asp?BasicDoc=MIL-PRF-12934">http://www.dsccl.dla.mil/Programs/MilSpec/ListDocs.asp?BasicDoc=MIL-PRF-12934</a>	RR	Wirewound Precision
Mil-PRF-19 <a href="http://www.dsccl.dla.mil/Programs/MilSpec/ListDocs.asp?BasicDoc=MIL-PRF-19">http://www.dsccl.dla.mil/Programs/MilSpec/ListDocs.asp?BasicDoc=MIL-PRF-19</a>	RA	Wirewound (Low Operating Temperature)
Mil-PRF-22097 <a href="http://www.dsccl.dla.mil/Programs/MilSpec/ListDocs.asp?BasicDoc=MIL-PRF-22097">http://www.dsccl.dla.mil/Programs/MilSpec/ListDocs.asp?BasicDoc=MIL-PRF-22097</a>	RJ	Non-Wirewound (Adjustment Type)
Mil_PRF-23285 <a href="http://www.dsccl.dla.mil/Programs/MilSpec/ListDocs.asp?BasicDoc=MIL-PRF-23285">http://www.dsccl.dla.mil/Programs/MilSpec/ListDocs.asp?BasicDoc=MIL-PRF-23285</a>	RVC	Non-Wirewound (Panel Control)
Mil-PRF-27208 <a href="http://www.dsccl.dla.mil/Programs/MilSpec/ListDocs.asp?BasicDoc=MIL-PRF-27208">http://www.dsccl.dla.mil/Programs/MilSpec/ListDocs.asp?BasicDoc=MIL-PRF-27208</a>	RT	Wirewound (Adjustment Type)
Mil-PRF-39015 <a href="http://www.dsccl.dla.mil/Programs/MilSpec/ListDocs.asp?BasicDoc=MIL-PRF-39015">http://www.dsccl.dla.mil/Programs/MilSpec/ListDocs.asp?BasicDoc=MIL-PRF-39015</a>	RTR	Wirewound (Lead Screw Actuated), Established Reliability
Mil-PRF-39023 <a href="http://www.dsccl.dla.mil/Programs/MilSpec/ListDocs.asp?BasicDoc=MIL-PRF-39023">http://www.dsccl.dla.mil/Programs/MilSpec/ListDocs.asp?BasicDoc=MIL-PRF-39023</a>	RQ	Non-Wirewound Precision
Mil-PRF-39035 <a href="http://www.dsccl.dla.mil/Programs/MilSpec/ListDocs.asp?BasicDoc=MIL-PRF-39035">http://www.dsccl.dla.mil/Programs/MilSpec/ListDocs.asp?BasicDoc=MIL-PRF-39035</a>	RJR	Non-Wirewound (Adjustment), Established Reliability
Mil-PRF-94 <a href="http://www.dsccl.dla.mil/Programs/MilSpec/ListDocs.asp?BasicDoc=MIL-PRF-94">http://www.dsccl.dla.mil/Programs/MilSpec/ListDocs.asp?BasicDoc=MIL-PRF-94</a>	RV	Composition

### Standards

Mil-STD-202 Detailed specification of test methods for electronic and mechanical component parts  
<http://www.dsccl.dla.mil/Programs/MilSpec/ListDocs.asp?BasicDoc=MIL-STD-202>

Mil-STD-690 Sampling plans and procedures for determining failure rates of established reliability devices  
<http://www.dsccl.dla.mil/Programs/MilSpec/ListDocs.asp?BasicDoc=MIL-STD-690>

Mil0STD-790 Reliability Assurance program for electronic parts and specifications  
<http://www.dsccl.dla.mil/Programs/MilSpec/ListDocs.asp?BasicDoc=MIL-STD-790>

### Handbook

Mil\_HDBK-199 Resistors, Selection and use of.  
<http://www.dsccl.dla.mil/Programs/MilSpec/ListDocs.asp?BasicDoc=MIL-HDBK-199>



## Appendix III. Bibliography of Further Reading

---

### SUBJECT INDEX TO BIBLIOGRAPHY

---

	Reference Number
ADJUSTMENT	15, 27, 28, 32, 36, 39
CERMET	30, 39
CIRCUITS	3, 4, 5, 8, 38
CONFORMITY	34, 36, 40
CONDUCTIVE PLASTIC	7, 14
CONTROL, AUTOMATIC (CRV)	36, 39
CONTROL, AUTOMATIC	5, 8
CONTACTS	25
ENVIRONMENTAL	13
ERROR	10, 11, 36
FREQUENCY	18, 34, 36
LINEAR	36
LINEARITY	10, 24, 33, 34, 36
LOADING	11, 22, 36
MEASUREMENT	10, 23, 24, 30, 36
NOISE	16, 22, 30, 34, 36, 40
NONLINEAR	22, 29, 34, 36
NONWIREWOUND	1, 7, 30, 32, 36
OUTPUT SMOOTHNESS	23, 36, 40
PACKAGING	6, 34
PHASE SHIFT	30, 36
POWER	12, 28, 34, 36
PRECISION	1, 3, 4, 5, 7, 8, 9, 10, 11, 13, 14, 17, 20, 21, 22, 29, 34, 36, 38, 40
QUADRATURE VOLTAGE	22, 30, 36
RELIABILITY	13, 17
RESOLUTION	30, 34, 36
RESISTANCE	35
RHEOSTAT	12, 36
SELECTION	7, 9, 15, 18, 19, 21, 27, 30, 31
TRACKING	22
TRIMMER	2, 8, 15, 19, 26, 27, 28, 32, 36, 37, 39
WIREWOUND	16, 30, 34, 36

---



## BIBLIOGRAPHY FOR FURTHER READING

Reference  
No.

- 1 ADISE, H.  
*Precision, Film Potentiometer*  
IRE Wescon Convention Record, 1960
- 2 BARKAN, Y.  
*A Realistic Look at Trimming Accuracy*  
Electromechanical Design Mag. Sept. 1969
- 3 BUCHBINDER, H.  
*Precision Potentiometers*  
Electromechanical Design Mag. Jan. 1964  
*Potentiometer Circuits*  
Electromechanical Design Mag. July 1966
- 4 CARLSTEIN, J.  
*Potentiometers*  
Electromechanical Design Mag. July 1969  
and Oct. 1969
- 5 DAVIS, S.  
*Rotating Components for Automatic Control*  
Product Engineering Nov. 1953  
*Potentiometers*  
Electromechanical Design Mag. April 1969  
*Todays Precision Potentiometers*  
Electromechanical Design Mag. Oct. 1970
- 6 DOERING, J.  
*Precision Potentiometer Installation*  
Electromechanical Design Mag. May 1971
- 7 DYER, S.  
*Nonwirewound Pots: Subtle Tradeoffs*  
*Yield Benefits*  
Spectrol Electronics Corp.
- 8 ELECTROMECHANICAL DESIGN  
MAGAZINE  
*Potentiometer Circuits* July 1967 and  
Jan. 1968  
*Optimum Potentiometers* Oct. 1968  
*Trimming Potentiometers* Sept. 1970  
*System Designers Handbook* 1973-74
- 9 FIELDS, R.  
*Potentiometer — How to Select and Use a  
Precision One*  
Instruments and Control Systems Mag.  
Aug. 1974
- 10 FRITCHLE, F.  
*Theory, Measurement and Reduction of  
Precision Potentiometer Linearity Errors*  
Helipot Division, Beckman Instruments,  
Inc.
- 11 GILBERT, J.  
*Use Taps to Compensate Potentiometer  
Loading Errors*  
Control Engineer Mag. Aug. 1956
- 12 GRANCHELLI, R.  
*Power Rating of Potentiometer Rheostats*  
Electromechanical Design Mag. Sept. 1971
- 13 GREEN, A. and K. SCHULZ  
*Environmental Effects on Precision  
Potentiometers*  
IRE Wescon Convention Record 1956
- 14 HARDMAN, K.  
*Conductive Plastic Precision Potentiometers*  
Electromechanical Design Mag. Oct. 1963
- 15 HENWOOD, R.  
*Adjustment Potentiometers — Which Way  
to Go*  
Electronic Products Mag. May 1972
- 16 HOGAN, I.  
*Electrical Noise in Wirewound  
Potentiometers*  
Proceedings of Wescon 1952
- 17 HOUDYSHELL, H.  
*Precision Potentiometer Life and Reliability*  
Electronics Component Conference 1955
- 18 JOHNSTON, S.  
*Selecting Trimmer Potentiometers for High  
Frequency and Pulse Applications*  
Amphenol Controls Div.
- 19 KARP, H.  
*Trimmers Take a Turn for the Better*  
Electronics Mag. Jan. 1972
- 20 KING, G.  
*Precision Potentiometers*  
Electromechanical Design Mag. May 1971
- 21 LERCH, J.  
*Guidelines for the Selection of  
Potentiometers*  
EDN Mag. June 1973
- 22 LITTON  
*Handbook Of High Precision  
Potentiometers*  
Litton Industries, Inc. 1965
- 23 MARKITE CORP.  
*Specifying Output Smoothness,*  
Tech. Data No. TD-114
- 24 McDONALD, R. and I. HOGAN  
*Accuracy of Potentiometer Linearity  
Measurements*  
Tele-tech and Electronic Industries Mag.  
Aug. 1953
- 25 NEY CO., J. M.  
*Deflection Calculations for Multi-Fingered  
Contact Members*  
Ney Scope April-May-June 1967
- 26 ODESS, L.  
*Impedance — Sensitivity Nomograph Aids  
Design of Trimming Networks*  
Electronics Mag. Sept. 1973
- 27 PUSATERA, E.  
*A Designers Guide for Selecting  
Adjustment Potentiometers*  
Machine Design Mag. March 1967
- 28 RAGAN, R.  
*Power Rating Calculations for Variable  
Resistors*  
Electronics Mag. July 1973
- 29 SCATURRO, J.  
*Nonlinear Functions from Linear  
Potentiometers*  
E.E.E. Mag. Oct. 1963
- 30 SCHNEIDER, S.  
*An Appraisal of Cermet Potentiometers*  
Electronic Industries Mag. Dec. 1964  
and D. Silverman  
*Testing Nonwirewound Potentiometers for  
Resolution and Noise*  
Electro-Technology Mag. Oct. 1965  
and F. Hiraoka and C. Gauldin  
*Measurement and Correction of Phase  
Shift in Copper Mandrel Precision  
Potentiometers*



- Helipot Division, Beckman Instruments,  
Inc., Tech. Paper 552
- 31 STAPP, A.  
*Potentiometers — Changing to Meet  
Today's Needs*  
EDN Mag. Feb. 1974
- 32 TAYLOR, J.  
*Nonwirewound Trimmers*  
Electronics World Mag. April 1966
- 33 THOELE, W.  
*Which Pot Linearity*  
E.E.E. Mag. March 1965
- 34 T.I.C.  
*T.I.C. Potentiometer Handbook*  
Bomar/Technology Instrument Corp. 1968
- 35 TURNER, R.  
*ABC's of Resistance and Resistors*  
Howard W. Sams and Co., Inc. 1974
- 36 VARIABLE RESISTIVE COMPONENTS  
INSTITUTE (VRCI)  
Appendix I
- 37 VON VECK, G.  
*Trimming Potentiometers*  
Electromechanical Design Mag. Sept. 1970
- 38 WETZSTEIN, H.  
*Precision Potentiometer Circuits*  
Electromechanical Design Mag. Jan. 1966
- 39 WOODS, J. and H. PUGH  
*Contact Resistance and Contact Resistance  
Variation in Thickfilm Trimming  
Potentiometers*  
Proc. of 1971 E.C.C.
- 40 WORMSER, H.  
*Potentiometer Output Smoothness*  
Electronic Equipment Engineering Mag.  
Oct. 1962  
*Conformity in Precision Potentiometers*  
Electromechanical Design Mag. Mar. 1970  
*Recent Studies in Potentiometer Output  
Smoothness*  
Markite Corp. Tech. Data No. TD-111



# Appendix IV. Metric Conversion Table

## INCHES TO MILLIMETERS

Basis: 1 in. = 25.4 mm (exactly). All values in this table are exact.

inch	millimeter	inch	millimeter	inch	millimeter	inch	millimeter
0.001	0.025 4	0.010	0.254 0	0.100	2.540 0	1.000	25.400 0
0.002	0.050 8	0.020	0.508 0	0.200	5.080 0	2.000	50.800 0
0.003	0.076 2	0.030	0.762 0	0.300	7.620 0	3.000	76.200 0
0.004	0.101 6	0.040	1.016 0	0.400	10.160 0	4.000	101.600 0
0.005	0.127 0	0.050	1.270 0	0.500	12.700 0	5.000	127.000 0
0.006	0.152 4	0.060	1.524 0	0.600	15.240 0	6.000	152.400 0
0.007	0.177 8	0.070	1.778 0	0.700	17.780 0	7.000	177.800 0
0.008	0.203 2	0.080	2.032 0	0.800	20.320 0	8.000	203.200 0
0.009	0.228 6	0.090	2.286 0	0.900	22.860 0	9.000	228.600 0

## MILLIMETERS TO INCHES

Basis: 1 mm = 1/25.4 in. (exactly). The inch value in tables below are rounded to the seventh decimal place.

millimeter	inch	millimeter	inch	millimeter	inch	millimeter	inch
0.001	0.000 039 4	0.010	0.000 393 7	0.100	0.003 937 0	1.000	0.039 370 1
0.002	0.000 078 7	0.020	0.000 787 4	0.200	0.007 874 0	2.000	0.078 740 2
0.003	0.000 118 1	0.030	0.001 181 1	0.300	0.011 811 0	3.000	0.118 110 2
0.004	0.000 157 5	0.040	0.001 574 8	0.400	0.015 748 0	4.000	0.157 480 3
0.005	0.000 196 9	0.050	0.001 968 5	0.500	0.019 685 0	5.000	0.196 850 4
0.006	0.000 236 2	0.060	0.002 362 2	0.600	0.023 622 0	6.000	0.236 220 5
0.007	0.000 275 6	0.070	0.002 755 9	0.700	0.027 559 1	7.000	0.275 590 6
0.008	0.000 315 0	0.080	0.003 149 6	0.800	0.031 496 1	8.000	0.314 960 6
0.009	0.000 354 3	0.090	0.003 543 3	0.900	0.035 433 1	9.000	0.354 330 7
millimeter	inch	millimeter	inch	millimeter	inch	millimeter	inch
10.000	0.393 700 8	20.000	0.787 401 6	30.000	1.181 102 4	40.000	1.574 803 1
11.000	0.433 070 9	21.000	0.826 771 7	31.000	1.220 472 4	41.000	1.614 173 2
12.000	0.472 440 9	22.000	0.866 141 7	32.000	1.259 842 5	42.000	1.653 543 3
13.000	0.511 811 0	23.000	0.905 511 8	33.000	1.299 212 6	43.000	1.692 913 4
14.000	0.551 181 1	24.000	0.944 881 9	34.000	1.338 582 7	44.000	1.732 283 5
15.000	0.590 551 2	25.000	0.984 252 0	35.000	1.377 952 8	45.000	1.771 653 5
16.000	0.629 921 3	26.000	1.023 622 0	36.000	1.417 322 8	46.000	1.811 023 6
17.000	0.669 291 3	27.000	1.062 992 1	37.000	1.456 692 9	47.000	1.850 393 7
18.000	0.708 661 4	28.000	1.102 362 2	38.000	1.496 063 0	48.000	1.889 763 8
19.000	0.748 031 5	29.000	1.141 732 3	39.000	1.535 433 1	49.000	1.929 133 9



## Appendix V. Abbreviations and Mathematical Symbols

Abbreviation	Symbol	Designates
A		Adjustability
	AR	Adjustability of resistance
	AV	Adjustability of output voltage
A	A	Attenuator; attenuation
a	a	Ampere
b	b	Straight line, axis intercept
C	C	Capacitor; capacitance
C	°C	Centigrade, degrees
cm	cm	Centimeter
CR	Rc	Contact Resistance
CRV	CRV	Contact Resistance Variation
CCW	CCW	Counter clockwise
CW	CW	Clockwise
D	D	Diode
d	d	Dimension; i.e., diameter or width
$\frac{d(1)}{d(2)}$	$\frac{d(1)}{d(2)}$	The rate of change of 1 with respect to 2
DIP		Dual in-line package
DOM		Digital ohmmeter
DVM		Digital voltmeter
E	V	Electromotive force; voltage d.c.
e	v	Electromotive force; voltage a.c.
E <sub>i</sub>	E <sub>i</sub>	Input voltage
ENR	ENR	Equivalent noise resistance
E <sub>o</sub>	E <sub>o</sub>	Output voltage
ER	R <sub>E</sub>	End resistance
$f( )$	$f( )$	A function of ( )
G	G	Gain
Hz	Hz	Hertz; cycles per second
I	I	Current, d.c.
i	i	Current, a.c.
IC	IC	Integrated circuit
IR	IR	Insulation resistance
K, k	K, k	Kilo, 10 <sup>3</sup>
K	K	Conformity
k	k	Linearity
KUR		Kills (Underhandedly) Resistors
L	L	Inductor; inductance
l	l	Dimension; length
M	M	Mega; 10 <sup>6</sup>
M	M	Meter; measuring instrument
m	m	Milli; 10 <sup>-3</sup>
m	m	Slope of a straight line
mm	mm	Millimeter
MR	RM	Minimum Resistance
N	N	Number of turns
OS	OS	Output smoothness
P	P	Power; electrical
p	p	Power derating factor



PC		Printed circuit
PPM	PPM	Parts per million
Q	Q	Quality factor
Q	Q	Transistor
R	R	Resistor; resistance
RL	RL	Load resistance
RTC	RTC	Resistance temperature characteristic
S	S	Cross sectional area
S	S	Switch
T	T	Temperature
T, t	T, t	Time; time interval
TC	TC	Temperature coefficient
TR	R <sub>T</sub>	Total resistance
TCVR		Temperature compensated voltage reference
V	V	Volt(s) d.c.
v	v	Volt(s) a.c.
VOM		Volt-ohm-meter
VR		Voltage reference
VRCI		Variable Resistive Components Institute
w	w	Watt(s) of power
X		Reactance
	X <sub>C</sub>	Reactance, capacitive
	X <sub>L</sub>	Reactance, inductive
Z	Z	Impedance
$\propto$	$\propto$	Proportional to
$\partial$	$\partial$	Partial differentiation
<	<	Less than
>	>	Greater than

#### Greek alpha-symbols

Symbol	Name	Designates
$\alpha$	alpha	index point output ratio
$\beta$	beta	output ratio
$\Delta$	delta	a change in
$\delta$	delta	output error
$\eta$	eta	ratio of compensation to load resistances
$\theta$	theta	travel; wiper position
$\theta_A$		actual travel
$\theta_I$		travel distance to index point
$\theta_M$		mechanical travel
$\theta_T$		theoretical travel
$\theta_W$		actual wiper position
$\lambda$	lamda	denotes photocell diode
$\rho$	rho	resistivity
$\Omega$	omega	ohms; resistive or reactive
$\omega$	omega	frequency

#### Atomic Symbols

Symbol	Designates
Ag	Silver
Au	Gold
Cr	Chromium
Cu	Copper
Ni	Nickel
Pt	Platinum



# INDEX



- Abbreviation, 289
- Absolute:
  - conformity, 40
  - linearity, 41
  - minimum resistance, 18
  - vs terminal based linearity, 45
- Access for adjustment, 186
- Access hole, 186
- Accessibility of adjustment, 178
- Accuracy of output (*see* Adjustability)
- Accuracy, construction factor, 121
- Actual electrical travel, 39
- Actuator, 166
  - leadscrew, 167
  - linear, 169
  - worm gear, 169
- Adjustability, 12, 52
  - definition, 31
  - in-circuit resistance, 32
  - optimizing, 62
  - output voltage ratio, 32
  - variable current mode, 65
- Adjustment:
  - access, 186
  - access hole, 186
  - accessibility, 178
  - by skilled technician, 178
  - field, 178
  - in subassemblies, 178
  - limited access, 186
  - potentiometer, 77
  - range, 59
  - range rheostat, 68
- Adjustment:
  - range, controlling, 68
  - set and forget, 77
  - tool guide, 186
- Aircraft, V/STOL, 136
- Angular travel distance, 39
- Anti-rotation pin, 189, 194
- Appendices, 209
- Application:
  - as a circuit adjustment device, 77
  - as a control device, 97
  - as a precision device, 115
  - as a voltage divider, 51
  - audio control, 171
  - clock generator, 88
  - contact resistance carbon element, 154
  - current limit adjustment, 80
  - custom design, 92
  - data conversion, 88
  - dendrometer, 137
  - digital circuit, 87
  - digital voltmeter, 90
  - diode reference supply, 81
  - filter, 85
  - function generator, 101
  - fundamentals, 51
  - gain adjustment, 83
  - generator, 90
  - instrument, 89
  - linear motion to rotary motion transducer, 133
  - master mixer board, 106, 171
  - meter, 104



- Application:
  - miscellaneous adjustment, 91
  - monostable timing, 87
  - monostable time delay, 87
  - motor speed control, 109
  - multifunction control, 112
  - non linear network, 92
  - oscilloscope adjustment, 90
  - oscilloscope controls, 101
  - phase locked loop, 91
  - photocell sensitivity, 88
  - photometer, 104
  - portable electronic thermometer, 91
  - position indication/transmission, 135
  - power supply, 78, 101
  - recorder, 104
  - rf tuning, 92
  - strip-chart, 104
  - tape deck, 89
  - temperature compensating supply, 81
  - temperature control, 111
  - variable capacitance, 85
  - wirewound carbon, 157
  - X-Y recorder, 104
- Attenuator, 109
- Audio, 104
  - level control, 171
  - logarithmic resistance variation, 104
  - taper, 106
- Automatic clutching, 168, 169
- Backlash, 12, 128
  - dial, 72
- Beckman, Arnold O., 6
  - patent, 8
- Bending pin, 189
- Bibliography, 283
- Board spacing, 186
- Bourns, Marlan E., 6
  - patent, 9
- Bracket mounting, 180
- Brake, friction, 101
- Brazing, silver, 159
- Bridged H attenuator, 109
- Bridged T attenuator, 109
- Bulk metal:
  - element selection factor, 154
  - element, 154
  - element, limitation, 155
  - temperature coefficient, 154
- Bushing, 127
  - mounting, 186
- Cable strain relief, 189
- Calibration:
  - adjustment, 178
  - function, 97, 101
- Capacitance during adjustment, 180
- Carbon block, 2
- Carbon element, 12, 152
  - advantages, 154
  - altering geometry, 152
  - changing resistivity, 152
  - moisture resistance, 154
  - molded, 153
  - processing, 152
  - range, 154
- Carbon element:
  - selection factor, 153
- Carbon pile, 2
- Card (*See* Mandrel)
- Cascaded ganged linear, 126
- Case (*See* Housing)
- Ceramic, 150
  - firing kiln, 150
  - substrate, 150
- Cermet:
  - element, 149
  - element termination, 162
  - ink composition, 150
  - selection factor, 152
  - T.C., 65
  - thermal characteristic, 68
- Characteristic, temperature, 34
- Charts, logging, 73
- Circuit adjustment, application, 77
- Circuit board behind panel, 187
- Clamping, voltage, 125
- Cleaning technique, 191
- Clips, termination, 159
- Clock generator, 88
- Clockwise audio taper, 106
- Closed loop function, 127
- Clutching, automatic, 168, 169
- Coarse/fine dual control, 134
- Coil of resistance wire, 11
- Collector, current, 157
- Compensation of loading error, 125
- Composition of resistive ink, 150
- Concentric shaft, 134
- Conductive plastic, 153
  - element, limitation, 154
  - nonlinear element, 157
  - plus wirewound, 155
  - selection factor, 153
  - temperature coefficient, 153
- Conformal coating, 180
- Conformity, 37, 126
  - evaluation, 39
  - absolute, 40
  - index point, 39
- Connection to element, 159
- Construction:
  - details and selection guideline, 143
  - factors, wirewound, 121
  - selection factor, 171
- Contact, 163
  - current crowding, 165
  - multiple finger, 166
  - multiwire, 166
  - physical form, 163
  - (*Also see* Wiper)
- Contact resistance, 22, 130
  - bulk metal elements, 155
  - changes in, 131
  - current sensitivity, 26
  - lowest value, 131
  - surface films, 22
  - variation (*See* CRV)
- Continuous rotation, 129
- Control function, 97
  - actual, 98
  - adjustment range, 68
  - application, 97



- Control function:
  - basic, 98
  - coarse/fine dual, 134
  - design factor, 112
  - direction of control sense, 99
  - environmental and stability, 101
  - human engineering, 99
  - instrument, 101
  - location, 101
  - motor speed, 109
  - mounting, 186
  - multifunction application, 112
  - phase shift, 106
  - photometer application, 104
  - RC, 106
  - range and resolution, 99
  - sense changing, 100
  - shape, 101
  - temperature, 111
  - worst case, 100
- Copper wire mandrel, 144
- Copper-nickel resistance wire, 144
- Cost-effective component, 77
- Counter-clockwise audio taper, 106
- CRV, 26
  - and ENR, 29
  - multiple contact wiper, 166
  - scope trace evaluation, 26
- Current:
  - collector, 157
  - crowding, 165
  - limit adjustment, 80
  - load, 55
  - maximum load, 65
  - maximum rheostat, 66
  - maximum wiper, 55
  - sensitivity of contact resistance, 26
  - tap, 132
  - wiper, 65
- Custom design, 92
- Data conversion, 88
- Data input, 71
- Demonstration of TC, 34
- Dendrometer, 137
- Derating power, 116
- Dial, 13, 71
  - clock face, 72
  - data input, 71
  - digital readout, 72
  - effective resolution, 72
  - mechanical factor, 72
  - multi-turn, 72
  - readability, 72
  - turns counting, 135
- Digital circuits, 87
  - magnetic tape deck, 89
  - monostable timing, 87
  - photocell sensitivity, 88
- Digital readout dial, 72
- Digital voltmeter, 90
- Diode reference supply application, 81
- Direct drive, 169
- Distance, angular travel, 39
- Distributed capacitance, 180
- Dither, 135
- Drive, direct, 169
- Dual bridged T attenuator, 109
- Effect of:
  - linearity, voltage divider, 52
  - resolution, rheostat, 65
  - rheostat, 65
  - TC, 52
  - voltage divider, 52
- Electrical:
  - overtravel, 128
  - parameter, 17
  - travel, 131
    - actual, 39
    - nonwirewound potentiometer, 131
    - theoretical, 39, 131
- Electronic thermometer application, 91
- Element, resistive, 143
  - bulk metal, 154
  - carbon, 152
  - cermet, 149
  - coil of resistance wire, 11
  - conductive plastic, 153
  - hybrid, 155
  - loading, 124
  - metal film, 154
  - nonwirewound, 149
  - shape, 149
  - summary, 157
  - termination, 159
  - wire material, 144
  - wire resistivity, 144
  - wirewound, 143
    - wirewound – carbon, 155
- Encapsulant barrier, 191
- Encapsulation, 191
- End:
  - and minimum voltage ratio, 20
  - play, 129
  - points, theoretical, 39
  - resistance, 20
  - setting, 20
  - voltage demonstration circuit, 21
- ENR, 28
- ENR and CRV, 29
- Environmental and stability, 101
- Equivalent noise resistance (*see* ENR)
- Error compensation, 62, 125
- Error, loading, 55, 59
- Extension, shaft, 101
- Factor, winding, 148
- Feedback transducers, linear position, 169
- Field adjustment, 178
- Filter resolution, 35
- Filter, output smoothness, 31
- Firing:
  - and printing of inks, 150
  - element and termination, 161
  - kiln, 150
  - substrate, 152
- Fixed resistor, 78
  - at end of element, 59
  - in parallel, 68
  - in series, 203
  - vs potentiometer, 78



- Flux, 189, 191
- Flux removal, 191
- Form, 180
- Forsterite, 150
- Frequency characteristic, 118
  - bulk metal, 155
  - carbon, 154
  - cermet, 152
  - conductive plastic, 154
  - phase shift, 118
  - quadrature voltage, 118
  - wirewound, 149
- Friction brake, 101
- Front panel space, 180
- Function:
  - by multiple tap, 127
  - closed loop, 127
  - linear, 120
  - transfer, 40
  
- Ganged cascaded linear, 126
- Ganged network, 126
- Generic name, 14
- Gold-platinum resistance wire, 144
- Grounded potentiometer, 180
  
- H-pad attenuator, 109
- Heat dissipation, 47
- Heat treatment, metal film, 154
- High temperature capability, 118
- Historical background, 1
- Historical motor speed control, 2
- Hot molded carbon, 153
- Housing, 171
- Human engineering, 99
- Humidity, 132
- Hybrid element, 155
- Hybrid element selection factor, 157
  
- Impedance output, 118
- Impedance, input, 118
- Independent linearity, 42
- Index point, 39
- Industry standard (*see* Appendix I)
- Ink (*see* resistive ink)
- Input impedance, 118
- Instrument control, 101
- Instruments, 89
- Insulated shaft extension, 187
- Insulation resistance, 47
- Internal temperature, 53
- Introduction to potentiometer, 1
- Inverted potentiometer, 186
  
- Kiln, 150
- KUR Killapot, 193
  
- L-Pad attenuator, 109
- Lateral runout, 129
- Leadscrew actuator, 167
- Lead, avoid pulling, 189
- Lighting level control, 112
- Linear actuated potentiometer, 169
- Linear actuator, 169
- Linear displacement transducer, 133
- Linear function, 120
- Linear motion potentiometer, 106
- Linear motion to rotary motion transducer, 133
- Linear taper, 106
- Linearity, 40, 120
  - absolute, 141
  - nonwirewound potentiometer, 42
  - optimization, 91
  - terminal based, 45
  - zero based, 42
- Little, Georg, 4
- Load current, 55
- Load ratio, 131
- Loading, 124
  - characteristics of ganged potentiometer, 126
  - compensation, 62
  - effect, 54
  - error, 55, 59
  - error compensation, 125
  - error, voltage divider maximum, 61
  - error, zero, 59
  - for nonlinear function, 126
  - maximum current, 65
  - output, 131
  - the resistive element, 124
  - the wiper, 124
- Logging chart and table, 73
- Logarithmic resistance variation, 104
- Low torque potentiometer, 133
- Lubricant, 163
  
- MacLagan, H. P., 4
- Mandrel:
  - shape, 146
  - stepped, 147
  - wirewound element, 144
- Master mixer board, 106, 171
- Material of resistance wire, 144
  - mathematical symbol, 289
- Maximum:
  - current, load, 65
  - current, rheostat, 66
  - loading error, voltage divider, 61
  - power dissipation, 55
  - power rating, 47, 55
  - resistance (*see* total resistance)
  - slope ratio, 148
  - wiper current, 68
  - wiper current rating, 13
- Mechanical:
  - backlash, 12, 128
  - factors, dial, 72
  - offset, 73
  - overtravel, 128
  - parameter, 127
    - mounting, 127
    - running torque, 128
    - starting torque, 127
  - runout, 129
  - runout, pilot diameter, 129
  - travel, 37
- Metal clip termination, 162



- Metal film element, 154
- Meters in application, 104
- Metric conversion, 287
- Military specification, 104, 259
- Minimum and end voltage ratio, 20
- Minimum resistance, 18, 20
- Minimum voltage demonstration circuit, 21
- Misapplication, 193
  - big knob, 197
  - big soldering iron, 199
  - check-out burn-out, 202
  - circuit surprise, 205
  - doing the twist, 197
  - domino effect, 201, 205
  - excessive power, 202
  - external cable, 206
  - failure induced, 205
  - flux, 200
  - flux it again, 200
  - handy handle, 198
  - high voltage surprise, 206
  - hotter n' hot, 199
  - it takes time, 199
  - jam session, 194
  - KUR Killapot, 193
  - mayhem, 194
  - mechanical strain, 194, 202
  - more power to the pot, 202
  - near source of heat, 194
  - overtwist a terminal, 197
  - pull hard on terminal, 196
  - save a nut and bolt, 195
  - short stuff, 206
  - slaughtering, 199
  - solvent soak, 200
  - squeeze play, 196
  - stacking several trimmers, 196
  - tipover terror, 198
  - too much wiper current, 203
  - tug o' war, 196
  - up the wiper current, 203
  - versatile cable clamp, 195
  - VOM plus a pot equals a no-no, 202
  - wave soldering, 199
  - zap, 201
  - zap it later, 203
  - zappo, 205
- Miscellaneous application, 91
- Moisture sensitivity, 132
- Molded carbon, 153
- Monostable timing application, 87
- Motor speed control application, 109
- Mounting, 127, 180
  - brackets, 180
  - controls, 186
  - for vibration, 180
  - hardware, 187
  - methods, 180
  - reinforcement, 180
  - snap-in, 187
  - space, 180
  - trimmer, 180
- Multi-wire wiper, 166
- Multifunction control application, 112
- Multiple contact wiper vs. CRV, 166
- Multiple tap, 127, 132
- Multiple taps, nonwirewound, 132
- Multiple-fingered wipers (*See* multi-wire)
- Multiturn dial, 72
- Negative shift, T.C., 65
- Networks, nonlinear, 92
- Nickel-chromium resistance wire, 144
- Noise conductive plastic, 154
- Noise pickup, 180
- Noise, nonwirewound, 26 (*See* CRV)
- Noise, wirewound, 28 (*see* ENR)
- Nominal resolution
  - (*See* theoretical resolution)
- Non-shorting potentiometer, 121
- Nonconducting screwdriver, 180
- Nonlinear function, 101, 121
  - by loading, 126
  - with steep slope, 126
  - stepped mandrel, 147
  - producibility, 121
  - networks, 92
  - nonwirewound elements, 157
  - wirewound elements, 146
  - wirewound elements, changing the wire, 147
  - straight-line approximation, 125
- Nonwirewound elements, 149
- Nonwirewound element multiple taps, 132
- Nonwirewound precision potentiometer, 130
- O-ring seal, 169
- Offset adjustment op-amp, 81
- Offset, mechanical, 73
- Ohm, 2
- Operational amplifier application, 81
- Operational amplifier offset adjustment, 81
- Operational mode rheostat, 62
- Operational mode voltage divider, 51
- Optimizing resolution, 80
- Oscilloscope application, 90, 101
- Output:
  - accuracy (*See* adjustability)
  - impedance, 118
  - load ratio, 131
  - loading, 131
  - smoothness, 30
  - smoothness filter, 31
  - smoothness, bandpass filter, 31
  - smoothness, industry standard test circuit, 30
  - voltage ratio adjustability, 32
  - voltage variation, 30
- Overtravel, 128
- Packaging, 177, 180
  - adjustment accessibility, 178
  - restriction, 180
- Panel moisture seal, 180
- Panel seal, 101
- Parts per million, 33
- Percussion welded termination, 160
- Phase locked loop application, 91
- Phase shift, 118
- Phase shift control, 106
- Phasing, 129



Phasing point, 129  
 Photocell sensitivity application, 88  
 Pigtail termination, 159  
 Pilot diameter runout, 129  
 Pin bending, 189  
 Pin, anti-rotation, 189, 194  
 Pitch of winding, 147, 148  
 Plastic film element, 153  
 Plastics technology, 153  
 Point, index, 39  
 Point, phasing, 129  
 Point, theoretical end, 39  
 Porcelain, 150  
 Positioner RC, 106  
 Potentiometer:  
   basic schematic, 17  
   cost-effective component, 77  
   early form, 2  
   generic name, 14  
   grounded, 180  
   high power, 146  
   introduction to, 1  
   inverted, 186  
   linear actuated, 169  
   non-linear function, 101, 121  
   non-shorting, 121  
   origin of name, 4  
   packaging, 177  
   packaging guide, 180  
   practical development, 6  
   remote mounting, 80  
   simple slide wire, 3  
   slide, 106  
   tapped, 124  
   transfer function, 40  
   vs fixed resistor, 78  
 Potting, 191  
 Power:  
   derating, 54, 116  
   dissipation, 47, 53, 66  
   dissipation internal temperature, 53  
   dissipation, maximum, 55  
   and load current, 55  
   loss, 55  
   rating, 45  
   rating, loaded voltage divider, 55  
   rating, maximum, 55  
   rating, multicup unit, 116  
   rating, precision, 115  
   rating, rheostat, 66  
   rating, voltage divider, 52  
   supply application, 78, 101  
   supply output voltage adjustment, 78  
 Precise temperature control application, 111  
 Precision:  
   potentiometer configuration, 180  
   potentiometer control, 189  
   potentiometer, nonwirewound, 130  
   application, 115  
   power rating, 115  
 Pressure clips, 159  
 Printed circuit pin, 180  
 Printing and firing of ink, 150  
  
 Quadrature voltage, 118  
  
 Radial play, 129  
 Range:  
   of adjustment, 59  
   of control, 99  
   rheostat adjustment, 68  
   travel zero reference, 39  
 Ratchet action, 168  
 Ratio, shunt to element, 124  
 RC transmitter application, 106  
 Readability of dials, 72  
 Reciprocal function, 124  
 Recorder application, 104  
 Rectangular potentiometer, 168  
 Reference, zero, 39  
 Resistance, 18  
   end, 20  
   parameters, 65  
   ratio, shunt to element, 124  
   taper, 106, 155  
   temperature characteristic, 34  
   tolerance, 18  
   tolerance effect, 62  
   wire material, 144  
   wire resistivity, 144  
   wire temperature coefficient, 144  
   wire, copper-nickel, 144  
   wire, gold-platinum, 144  
   wire, nickel-chromium, 144  
   contact, 22  
   in-circuit adjustability, 32  
   insulation, 47  
   minimum, 18  
   output voltage ratio adjustability, 32  
   total, 18  
 Resistive:  
   element, carbon, 12  
   loading, 124  
   shape, 149  
   straight wire, 144  
   taper, 106  
   elements, 143  
   inks, composition, 150  
 Resistivity of resistance wire, 144  
 Resolution:  
   control, 99  
   definition, 34  
   estimation, 120  
   for a nonlinear function, 124  
   optimizing, 62, 80  
   theoretical, 34  
   travel, 35  
   voltage, 35  
   voltage filter time constant, 37  
 Retainer shaft, 168  
 RF tuning application, 92  
 Rheostat, 66  
   adjustment range, 68  
   choice of input output terminal, 62  
   historical, 6  
   maximum current, 66  
   mode, 62  
 Rotary shaft and wiper, 166  
 Rotation, continuous, 129  
 Running torque, 128  
 Runout, 129



Screening, 149  
 Screwdriver, nonconducting, 180  
 Seal:  
   housing, 171  
   O-ring, 169  
   to panel, 101  
   potentiometer, 191  
   shaft, 168  
 Secant function, 124  
 Selection factor:  
   bulk metal element, 154  
   cermet element, 152  
   conductive plastic, 153  
   construction features, 171  
   hybrid element, 157  
   metal film element, 154  
   taper, 155  
   wirewound element, 148  
 Servo potentiometer, 180  
 Servo system, 166  
 Servo-motor driven, 127  
 Set and forget vs fixed resistor, 78  
 Setability, 12  
 Shaft:  
   actuator, 167  
   end play, 129  
   extension, 101, 180  
   extension, insulated, 187  
   plain, slotted or flatted, 187  
   radial play, 129  
   retainer, 168  
   rotary and wiper, 166  
   runout, 129  
   seal, 168  
 Shape of element, 149  
 Shape of mandrel, 146  
 Shunt-to-element total resistance ratio, 124  
 Silk screen, 161  
 Silk screening, 149  
 Silver-braze, 159  
 Single turn-direct drive, 169  
 Single-wire tap, 159  
 Slide potentiometer, 106  
 Slide-wire potentiometer, 3  
 Slope ratio maximum, 148  
 Slope, steep, 126  
 Snap-in mounting, 187  
 Solder, 189  
   lug, 180  
   mask, 189  
   precaution, 189  
   termination, 159  
 Solvents, 191  
 Spacing of wire, 147, 148  
 Specification, military, 259  
 Split winding, 126  
 Square function, 124  
 Square potentiometer, 169  
 Square root function, 124  
 Stability and environmental, 101  
 Stabilizing heat treatment, 154  
 Standards VRCI, 211  
 Standards, industry (*See Appendix I*)  
 Starting torque, 127  
 Static stop strength, 129  
 Steatite, 150  
 Steep slope function, 126  
 Stepped mandrel, 147  
 Stop strength, static, 129  
 Straight wire element, 144  
 Stray capacitance, 180  
 Stress and strain, 189  
 Strip-chart application, 104  
 Substrate:  
   alumina, 150  
   beryllia, 150  
   ceramic, 150  
   firing, 152  
 Surface film, 22  
 Swaging, 161  
  
 T-pad attenuator, 109  
 Tangent function, 124  
 Taper, 104, 106  
 Taper selection factor, 155  
 Taper, approximation to the ideal, 155  
 Tapped potentiometer, 124  
 Tapping, 148  
 Tap, 132  
 TC:  
   calculation, 34  
   for cermet potentiometer, 152  
   conductive plastic, 153  
   of current rheostat, 65  
   demonstration circuit, 34  
   of finished potentiometer, 146  
   of resistance, 33, 132  
   of resistance wire, 144  
   voltage divider, 52  
 Temperature:  
   capabilities, 118  
   characteristic, 34  
   coefficient (*See TC*)  
   compensating voltage supply  
     application, 81  
   control application, 111  
   internal, 53  
 Tension, winding, 144  
 Terminal based linearity, 45  
 Terminals, 159  
 Terminal swaging, 161  
 Termination, 159  
   for cermet potentiometer, 160  
   conductive epoxy paste, 162  
   metal clip, 162  
   for nonwirewound element, 162  
   percussion welding, 160  
   pigtail, 159  
   pressure clips, 159  
   silk screening, 161  
   for wirewound potentiometer, 159  
 T.C. negative shift, 65  
 Theoretical electrical travel, 39, 131  
 Theoretical end point, 39  
 Theoretical resolution, 34  
 Thermometer, electronic, 91  
 Thick film (*See also Cermet*), 149  
 Threaded shaft, 167  
 Time constant voltage resolution filter, 37  
 Torque, 127  
   low, 133



- Torque:
  - running, 128
  - starting, 127
- Total mechanical travel, 37
- Total resistance, 18
- Tracking, 126
- Transfer function, 40
- Transmitter application, 106
- Travel:
  - distance, angular, 39
  - range zero reference, 39
  - resolution, 35
  - time, 35
  - total mechanical, 37
- Trimmer, 189
  - adjustment direction, 180
  - configurations, 180
  - mounting, 180
  - mounting hardware, 187
  - packaging, 177
    - (See also Adjustment)
- Trimming, 62, 77
- Tuning, RF application, 92
- Turns-counting dial, 135
- Two-terminal mode, 66
  
- Unsealed potentiometer, 189
  
- Vacuum deposit, 154
- Variable capacitance application, 85
- Variable current rheostat mode, 32, 51, 62
  - adjustability, 65
  - effects of TC, 65
- Variable resistance mode, 62
- Variable resistive components Institute
  - (VRCI) standard (See Appendix I), 17, 211
- Variable voltage divider mode, 51
- Voltage:
  - clamping, 125
  - divider maximum loading error, 61
  - divider mode, 32, 51
  - resolution, 35
  - resolution, filter time constant, 37
  - tap, 132
  - tracking error, 126
  
- Voltage:
  - quadrature, 118
- VRCI (See Variable resistive components institute)
- V/STOL aircraft, 136
  
- Water-tight seal, 101
- Wave soldering, 189
- Winding factor, 148
- Winding pitch, 147, 148
- Winding tension, 144
- Wiper, 166
  - current rating, 65
  - current, maximum, 68
  - to external terminal, 166
  - loading, 124
  - lubricant, 163
  - multiwire, 166
  - physical form, 163
    - and rotary shaft, 166
    - (See also Contact)
- Wire lead, 180
- Wire size, 147, 148
- Wire spacing, 148
- Wirewound element, 143
  - catastrophic failure, 12
  - frequency response, 149
  - mandrel, 144
  - plus conductive plastic, 155
  - selection factor, 148
- Wire, resistance, TC, 144
- Wire, resistivity, 144
- Wiring panel component, 187
- Worm gear actuated potentiometer
  - (square), 169
  
- X-22A, V/STOL aircraft, 136
  
- Zero:
  - based linearity, 42
  - loading error, 59
  - reference for travel range, 39
  - width tap, 132
- Zirconia, 150