

Relay leads MUST be strain relieved while being bent!!!

Both jumpers are on the other side over a solid ground plane.

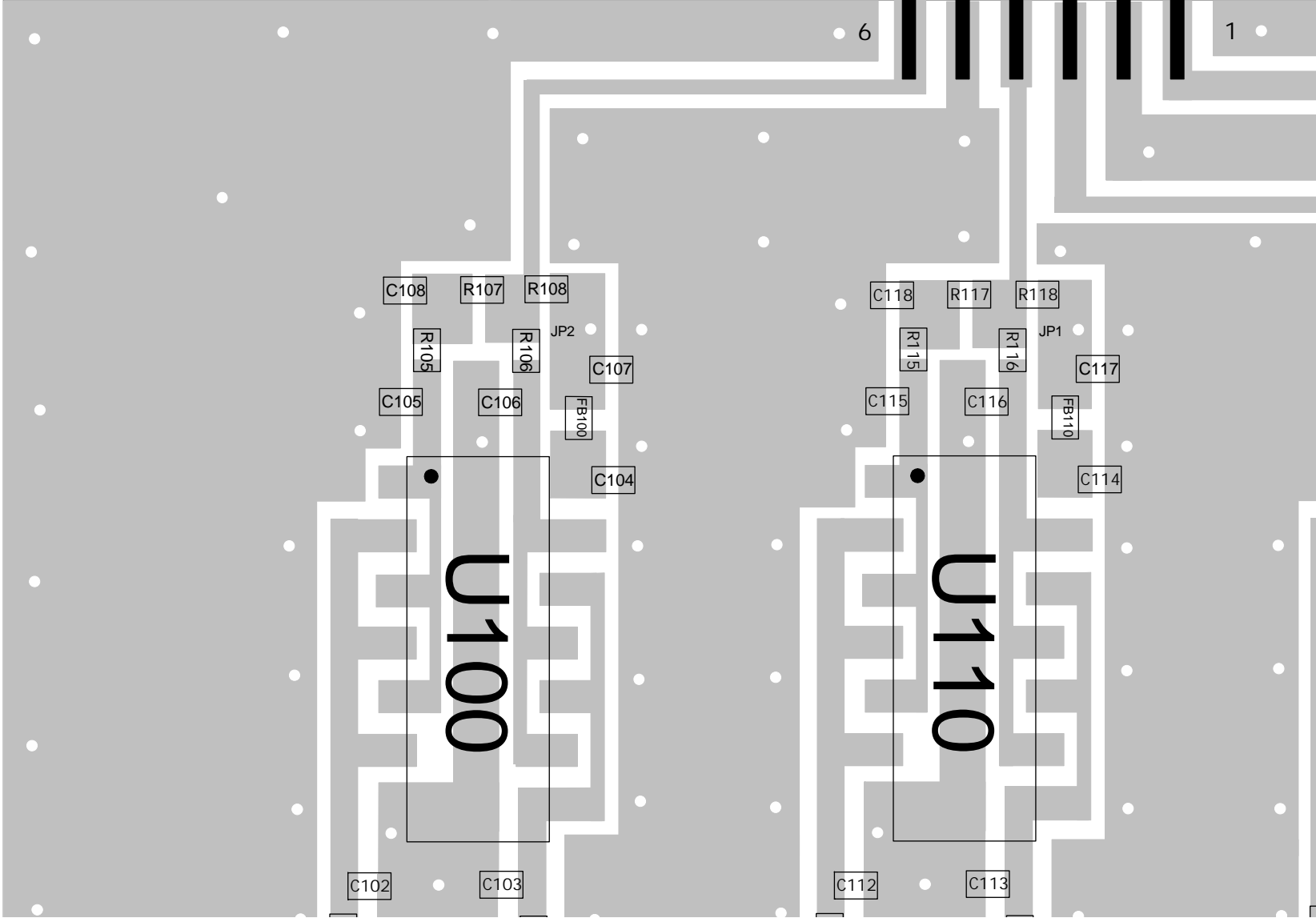

the other side  
plane.

TO VNA  
P130

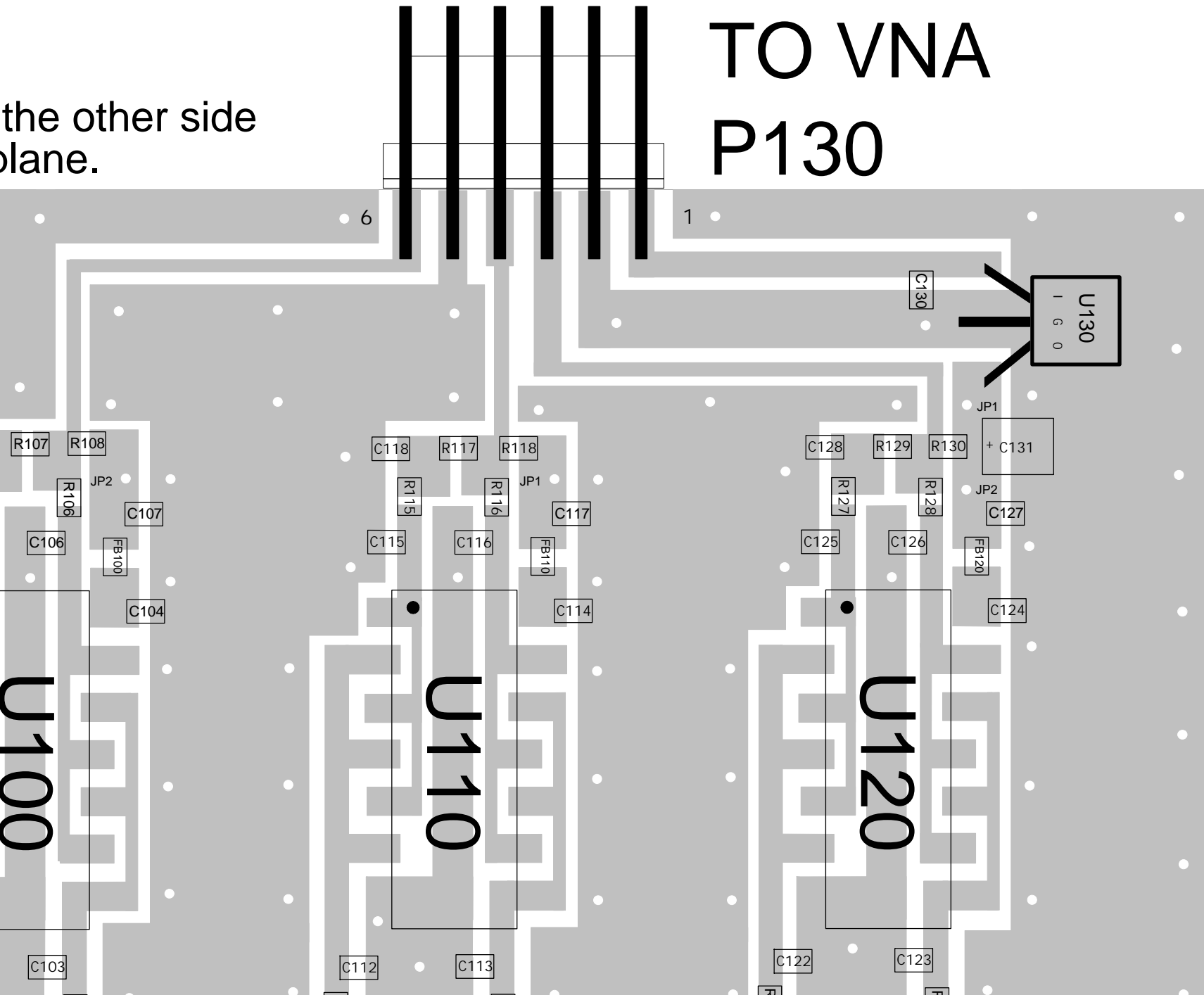

Transfe

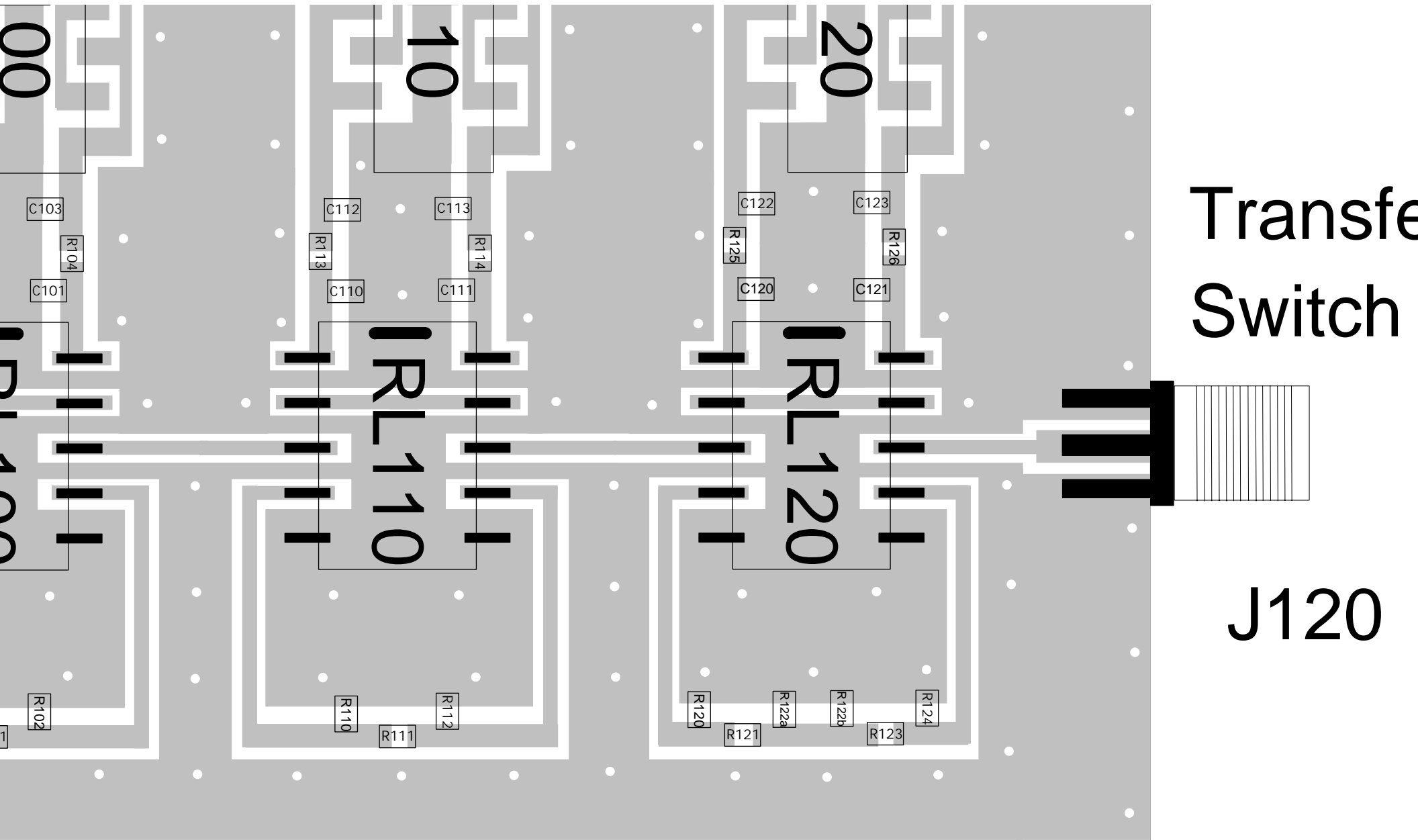

lay leads MUST be strain relieved while being bent!!!

RF DDS

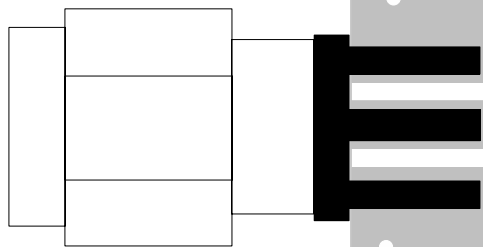

P100

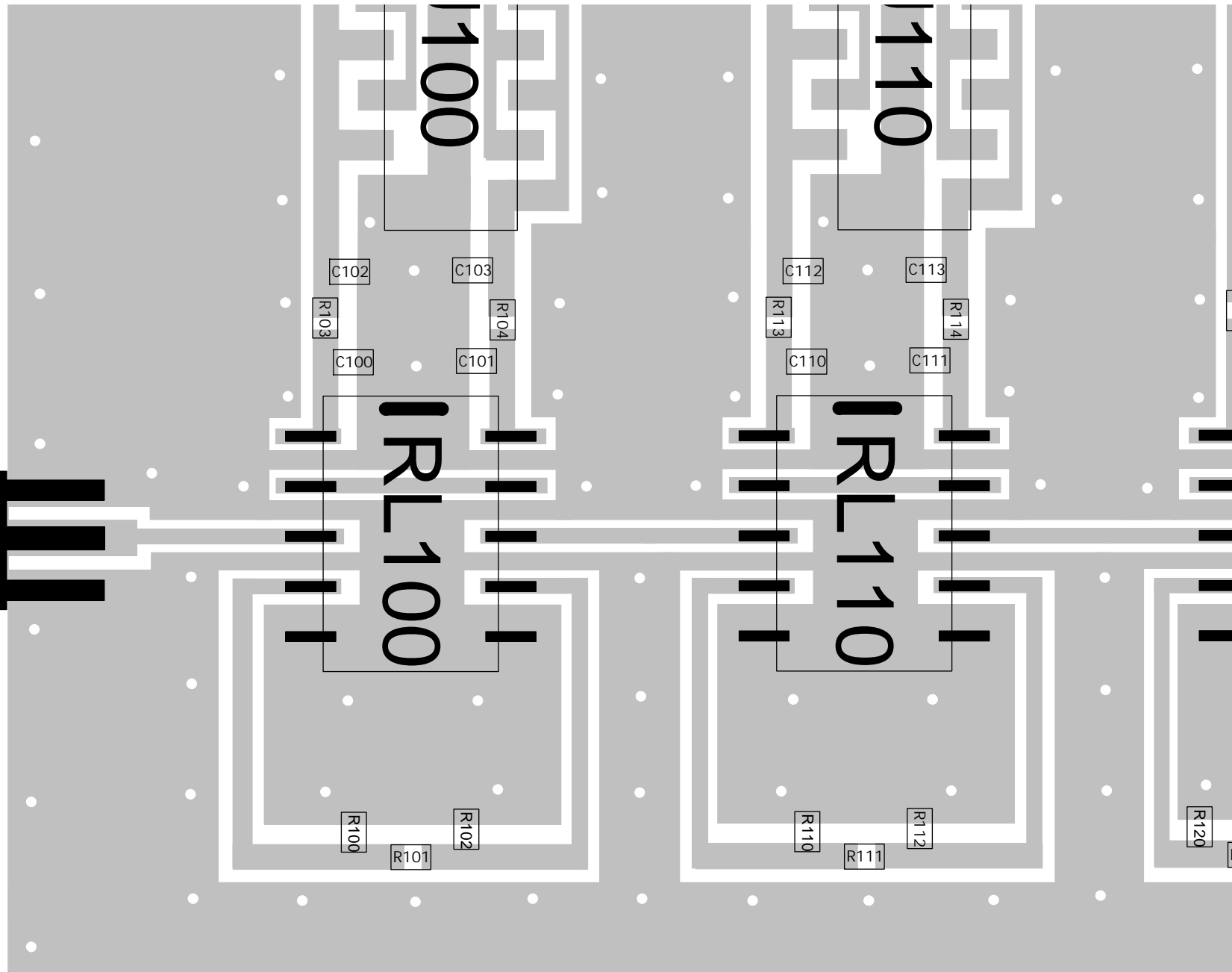

Relay leads MUST be strain relieved while l

Board outline: 3.382" x 3.049"

Top layer: Normal view

Bottom layer is solid copper

For proper artwork scaling, print in Acrobat 7 using "None" for Print Scaling.

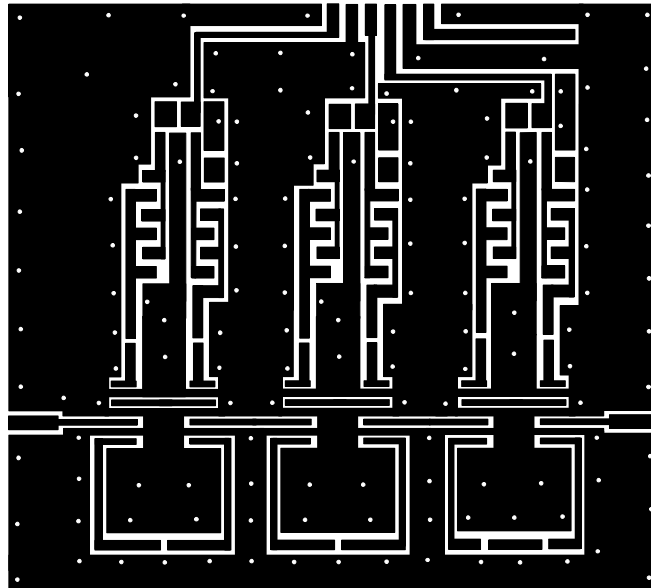

Top layer: Mirror view

Board outline: 3.382" x 3.049"

Bottom layer is solid copper

For proper artwork scaling, print in Acrobat 7 using "None" for Print Scaling.

