

BME280

Combined humidity and pressure sensor

Bosch Sensortec



BOSCH

Invented for life



BME280: Final data sheet

Document revision	1.1
Document release date	May 07 th , 2015
Document number	BST-BME280-DS001-10
Technical reference code(s)	0 273 141 185

Notes

Data in this document are subject to change without notice. Product photos and pictures are for illustration purposes only and may differ from the real product's appearance.

BME280

DIGITAL HUMIDITY, PRESSURE AND TEMPERATURE SENSOR

Key features

- Package 2.5 mm x 2.5 mm x 0.93 mm metal lid LGA
- Digital interface I²C (up to 3.4 MHz) and SPI (3 and 4 wire, up to 10 MHz)
- Supply voltage V_{DD} main supply voltage range: 1.71 V to 3.6 V
V_{DDIO} interface voltage range: 1.2 V to 3.6 V
- Current consumption 1.8 µA @ 1 Hz humidity and temperature
2.8 µA @ 1 Hz pressure and temperature
3.6 µA @ 1 Hz humidity, pressure and temperature
0.1 µA in sleep mode
- Operating range -40...+85 °C, 0...100 % rel. humidity, 300...1100 hPa
- Humidity sensor and pressure sensor can be independently enabled / disabled
- Register and performance compatible to Bosch Sensortec BMP280 digital pressure sensor
- RoHS compliant, halogen-free, MSL1

Key parameters for humidity sensor¹

- Response time ($\tau_{63\%}$) 1 s
- Accuracy tolerance ±3 % relative humidity
- Hysteresis ±1% relative humidity

Key parameters for pressure sensor

- RMS Noise 0.2 Pa, equiv. to 1.7 cm
- Offset temperature coefficient ±1.5 Pa/K, equiv. to ±12.6 cm at 1 °C temperature change

Typical application

- Context awareness, e.g. skin detection, room change detection
- Health monitoring / well-being
 - Warning regarding dehydration or heat stroke
 - Spirometry (measurement of lung volume and air flow)
- Home automation control
 - control heating, venting, air conditioning (HVAC)
- Internet of things
- GPS enhancement (e.g. time-to-first-fix improvement, dead reckoning, slope detection)
- Indoor navigation (change of floor detection, elevator detection)
- Outdoor navigation, leisure and sports applications
- Weather forecast
- Vertical velocity indication (rise/sink speed)

Target devices

- Handsets such as mobile phones, tablet PCs, GPS devices
- Navigation systems

¹ Target values

- Gaming, e.g flying toys
- Camera (DSC, video)
- Portable health care devices
- Home weather stations
- Flying toys
- Watches

General Description

The BME280 is as combined digital humidity, pressure and temperature sensor based on proven sensing principles. The sensor module is housed in an extremely compact metal-lid LGA package with a footprint of only $2.5 \times 2.5 \text{ mm}^2$ with a height of 0.93 mm. Its small dimensions and its low power consumption allow the implementation in battery driven devices such as handsets, GPS modules or watches. The BME280 is register and performance compatible to the Bosch Sensortec BMP280 digital pressure sensor (see chapter 5.2 for details).

The BME280 achieves high performance in all applications requiring humidity and pressure measurement. These emerging applications of home automation control, in-door navigation, health care as well as GPS refinement require a high accuracy and a low TCO at the same time.

The humidity sensor provides an extremely fast response time for fast context awareness applications and high overall accuracy over a wide temperature range.

The pressure sensor is an absolute barometric pressure sensor with extremely high accuracy and resolution and drastically lower noise than the Bosch Sensortec BMP180.

The integrated temperature sensor has been optimized for lowest noise and highest resolution. Its output is used for temperature compensation of the pressure and humidity sensors and can also be used for estimation of the ambient temperature.

The sensor provides both SPI and I²C interfaces and can be supplied using 1.71 to 3.6 V for the sensor supply V_{DD} and 1.2 to 3.6 V for the interface supply V_{DDIO} . Measurements can be triggered by the host or performed in regular intervals. When the sensor is disabled, current consumption drops to 0.1 μA .

BME280 can be operated in three power modes (see chapter 3.3):

- sleep mode
- normal mode
- forced mode

In order to tailor data rate, noise, response time and current consumption to the needs of the user, a variety of oversampling modes, filter modes and data rates can be selected.

Please contact your regional Bosch Sensortec partner for more information about software packages.

Index of Contents

1. SPECIFICATION	7
1.1 GENERAL ELECTRICAL SPECIFICATION	7
1.2 HUMIDITY PARAMETER SPECIFICATION	8
1.3 PRESSURE SENSOR SPECIFICATION	9
1.4 TEMPERATURE SENSOR SPECIFICATION	10
2. ABSOLUTE MAXIMUM RATINGS	10
3. FUNCTIONAL DESCRIPTION	11
3.1 BLOCK DIAGRAM	11
3.2 POWER MANAGEMENT	11
3.3 SENSOR MODES	12
3.3.1 SENSOR MODE TRANSITIONS	12
3.3.2 SLEEP MODE	13
3.3.3 FORCED MODE	13
3.3.4 NORMAL MODE	13
3.4 MEASUREMENT FLOW	14
3.4.1 HUMIDITY MEASUREMENT	15
3.4.2 PRESSURE MEASUREMENT	15
3.4.3 TEMPERATURE MEASUREMENT	15
3.4.4 IIR FILTER	15
3.5 RECOMMENDED MODES OF OPERATION	17
3.5.1 WEATHER MONITORING	17
3.5.2 HUMIDITY SENSING	17
3.5.3 INDOOR NAVIGATION	17
3.5.4 GAMING	18
3.6 NOISE	18
4. DATA READOUT	21
4.1 DATA REGISTER SHADOWING	21
4.2 OUTPUT COMPENSATION	21
4.2.1 COMPUTATIONAL REQUIREMENTS	21
4.2.2 TRIMMING PARAMETER READOUT	22
4.2.3 COMPENSATION FORMULAS	23
5. GLOBAL MEMORY MAP AND REGISTER DESCRIPTION	24
5.1 GENERAL REMARKS	24
5.2 REGISTER COMPATIBILITY TO BMP280	24
5.3 MEMORY MAP	24
5.4 REGISTER DESCRIPTION	25

5.4.1 REGISTER 0xD0 "ID"	25
5.4.2 REGISTER 0xE0 "RESET"	25
5.4.3 REGISTER 0xF2 "CTRL_HUM"	25
5.4.4 REGISTER 0xF3 "STATUS"	26
5.4.5 REGISTER 0xF4 "CTRL_MEAS"	26
5.4.6 REGISTER 0xF5 "CONFIG"	27
5.4.7 REGISTER 0xF7...0xF9 "PRESS" (_MSB, _LSB, _XLSB)	28
5.4.8 REGISTER 0xFA...0xFC "TEMP" (_MSB, _LSB, _XLSB)	29
5.4.9 REGISTER 0xFD...0xFE "HUM" (_MSB, _LSB)	29
6. DIGITAL INTERFACES.....	30
6.1 INTERFACE SELECTION.....	30
6.2 I ² C INTERFACE.....	30
6.2.1 I ² C WRITE	31
6.2.2 I ² C READ	31
6.3 SPI INTERFACE.....	32
6.3.1 SPI WRITE	33
6.3.2 SPI READ	33
6.4 INTERFACE PARAMETER SPECIFICATION	34
6.4.1 GENERAL INTERFACE PARAMETERS.....	34
6.4.2 I ² C TIMINGS	34
6.4.3 SPI TIMINGS	35
7. PIN-OUT AND CONNECTION DIAGRAM.....	37
7.1 PIN-OUT	37
7.2 CONNECTION DIAGRAM I ² C.....	38
7.3 CONNECTION DIAGRAM 4-WIRE SPI	39
7.4 CONNECTION DIAGRAM 3-WIRE SPI	40
7.5 PACKAGE DIMENSIONS	41
7.6 LANDING PATTERN RECOMMENDATION	42
7.7 MARKING.....	43
7.7.1 MASS PRODUCTION DEVICES	43
7.7.2 ENGINEERING SAMPLES.....	44
7.8 SOLDERING GUIDELINES AND RECONDITIONING RECOMMENDATIONS	45
7.9 RECONDITIONING PROCEDURE	46
7.10 TAPE AND REEL SPECIFICATION.....	46
7.10.1 DIMENSIONS	46
7.10.2 ORIENTATION WITHIN THE REEL.....	47
7.11 MOUNTING AND ASSEMBLY RECOMMENDATIONS	48
7.12 ENVIRONMENTAL SAFETY	48
7.12.1 RoHS	48
7.12.2 HALOGEN CONTENT	48
7.12.3 INTERNAL PACKAGE STRUCTURE.....	48

8. APPENDIX A: ALTERNATIVE COMPENSATION FORMULAS.....	49
8.1 COMPENSATION FORMULAS IN DOUBLE PRECISION FLOATING POINT	49
8.2 PRESSURE COMPENSATION IN 32 BIT FIXED POINT	50
9. APPENDIX B: MEASUREMENT TIME AND CURRENT CALCULATION	51
9.1 MEASUREMENT TIME.....	51
9.2 MEASUREMENT RATE IN FORCED MODE	51
9.3 MEASUREMENT RATE IN NORMAL MODE.....	51
9.4 RESPONSE TIME USING IIR FILTER	52
9.5 CURRENT CONSUMPTION.....	52
10. LEGAL DISCLAIMER.....	53
10.1 ENGINEERING SAMPLES.....	53
10.2 PRODUCT USE	53
10.3 APPLICATION EXAMPLES AND HINTS	53
10.4 HANDLING INSTRUCTIONS.....	53
11. DOCUMENT HISTORY AND MODIFICATION	54

1. Specification

If not stated otherwise,

- All values are valid over the full voltage range
- All minimum/maximum values are given for the full accuracy temperature range
- Minimum/maximum values of drifts, offsets and temperature coefficients are $\pm 3\sigma$ values over lifetime
- Typical values of currents and state machine timings are determined at 25 °C
- Minimum/maximum values of currents are determined using corner lots over complete temperature range
- Minimum/maximum values of state machine timings are determined using corner lots over 0...+65 °C temperature range

The specification tables are split into humidity, pressure, and temperature part of BME280.

1.1 General electrical specification

Table 1: Electrical parameter specification

Parameter	Symbol	Condition	Min	Typ	Max	Unit
Supply Voltage Internal Domains	V_{DD}	ripple max. 50 mVpp	1.71	1.8	3.6	V
Supply Voltage I/O Domain	V_{DDIO}		1.2	1.8	3.6	V
Sleep current	I_{DDSL}			0.1	0.3	μA
Standby current (inactive period of normal mode)	I_{DDSB}			0.2	0.5	μA
Current during humidity measurement	I_{DDH}	Max value at 85 °C		340		μA
Current during pressure measurement	I_{DDP}	Max value at -40 °C		714		μA
Current during temperature measurement	I_{DDT}	Max value at 85 °C		350		μA
Start-up time	$t_{startup}$	Time to first communication after both $V_{DD} > 1.58 V$ and $V_{DDIO} > 0.65 V$			2	ms
Power supply rejection ratio (DC)	PSRR	full V_{DD} range			± 0.01 ± 5	%RH/V Pa/V
Standby time accuracy	$\Delta t_{standby}$			± 5	± 25	%

1.2 Humidity parameter specification²

Table 2: Humidity parameter specification

Parameter	Symbol	Condition	Min	Typ	Max	Unit
Operating range ³	R _H	For temperatures < 0 °C and > 60 °C see Figure 1	-40	25	85	°C
			0		100	%RH
Supply current	I _{DD,H}	1 Hz forced mode, humidity and temperature		1.8	2.8	µA
Absolute accuracy tolerance	A _H	20...80 %RH, 25 °C, including hysteresis		±3		%RH
Hysteresis ⁴	H _H	10→90→10 %RH, 25 °C		±1		%RH
Nonlinearity ⁵	NL _H	10→90 %RH, 25 °C		1		%RH
Response time to complete 63% of step ⁶	τ _{63%}	90→0 or 0→90 %RH, 25 °C		1		s
Resolution	R _H			0.008		%RH
Noise in humidity (RMS)	N _H	Highest oversampling, see chapter 3.6		0.02		%RH
Long term stability	ΔH _{stab}	10...90 %RH, 25 °C		0.5		%RH/ year

² Target values

³ When exceeding the operating range (e.g. for soldering), humidity sensing performance is temporarily degraded and reconditioning is recommended as described in section 7.8. Operating range only for non-condensing environment.

⁴ For hysteresis measurement the sequence 10→30→50→70→90→70→50→30→10 %RH is used. The hysteresis is defined as the difference between measurements of the humidity up / down branch and the averaged curve of both branches

⁵ Non-linear contributions to the sensor data are corrected during the calculation of the relative humidity by the compensation formulas described in section 4.2.3.

⁶ The air-flow in direction to the vent-hole of the device has to be dimensioned in a way that a sufficient air exchange inside to outside will be possible. To observe effects on the response time-scale of the device an air-flow velocity of approx. 1 m/s is needed.

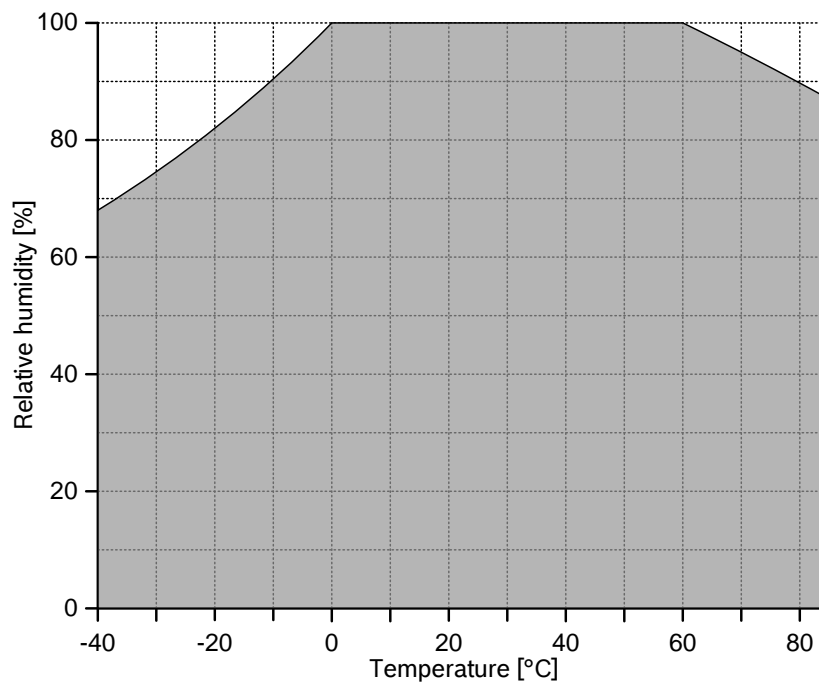

Figure 1: humidity sensor operating range

1.6 Pressure sensor specification

Table 3: Pressure parameter specification

Parameter	Symbol	Condition	Min	Typ	Max	Unit
Operating temperature range	T_A	operational	-40	25	+85	°C
		full accuracy	0		+65	
Operating pressure range	P	full accuracy	300		1100	hPa
Supply current	$I_{DD,LP}$	1 Hz forced mode, pressure and temperature, lowest power		2.8	4.2	μA
Temperature coefficient of offset ⁷	TCO_P	25...65 °C, 900 hPa		±1.5		Pa/K
				±12.6		cm/K
Absolute accuracy pressure	$A_{P,full}$	300 ... 1100 hPa 0 ... 65 °C		±1.0		hPa
Relative accuracy pressure $V_{DD} = 3.3V$	A_{rel}	700 ... 900hPa 25 ... 40 °C		±0.12		hPa

⁷ When changing temperature by e.g. 10 °C at constant pressure / altitude, the measured pressure / altitude will change by (10 × TCO_P).

Resolution of pressure output data	R_P	Highest oversampling		0.18		Pa
Noise in pressure	$N_{P,fullBW}$	Full bandwidth, highest oversampling See chapter 3.6		1.3		Pa
				11		cm
	$N_{P,filtered}$	Reduced bandwidth, highest oversampling See chapter 3.6		0.2		Pa
				1.7		cm
Solder drift		Minimum solder height 50 μ m	-0.5		+2.0	hPa
Long term stability ⁸	ΔP_{stab}	per year		± 1.0		hPa
Possible sampling rate	f_{sample_P}	Lowest oversampling, see chapter 9.2	157	182		Hz

1.7 Temperature sensor specification

Table 4: Pressure parameter specification

Parameter	Symbol	Condition	Min	Typ	Max	Unit
Operating range	T	Operational	-40	25	85	°C
		Full accuracy	0		65	°C
Supply current	$I_{DD,T}$	1 Hz forced mode, temperature measurement only		1.0		μ A
Absolute accuracy temperature ⁹	$A_{T,25}$	25 °C		± 0.5		°C
	$A_{T,full}$	0...65 °C		± 1.0		°C
Output resolution	R_T	API output resolution		0.01		°C
RMS noise	N_T	Lowest oversampling		0.005		°C

2. Absolute maximum ratings

The absolute maximum ratings are determined over complete temperature range using corner lots. The values are provided in Table 5.

⁸ Long term stability is specified in the full accuracy operating pressure range 0 ... 65 °C

⁹ Temperature measured by the internal temperature sensor. This temperature value depends on the PCB temperature, sensor element self-heating and ambient temperature and is typically above ambient temperature.

Table 5: Absolute maximum ratings

Parameter	Condition	Min	Max	Unit
Voltage at any supply pin	V_{DD} and V_{DDIO} pin	-0.3	4.25	V
Voltage at any interface pin		-0.3	$V_{DDIO} + 0.3$	V
Storage temperature	$\leq 65\%$ RH	-45	+85	$^{\circ}\text{C}$
Pressure		0	20 000	hPa
ESD	HBM, at any pin		± 2	kV
	CDM		± 500	V
	Machine model		± 200	V
Condensation	No power supplied	Allowed		

3. Functional description

3.1 Block diagram

Figure 2 shows a simplified block diagram of the BME280:

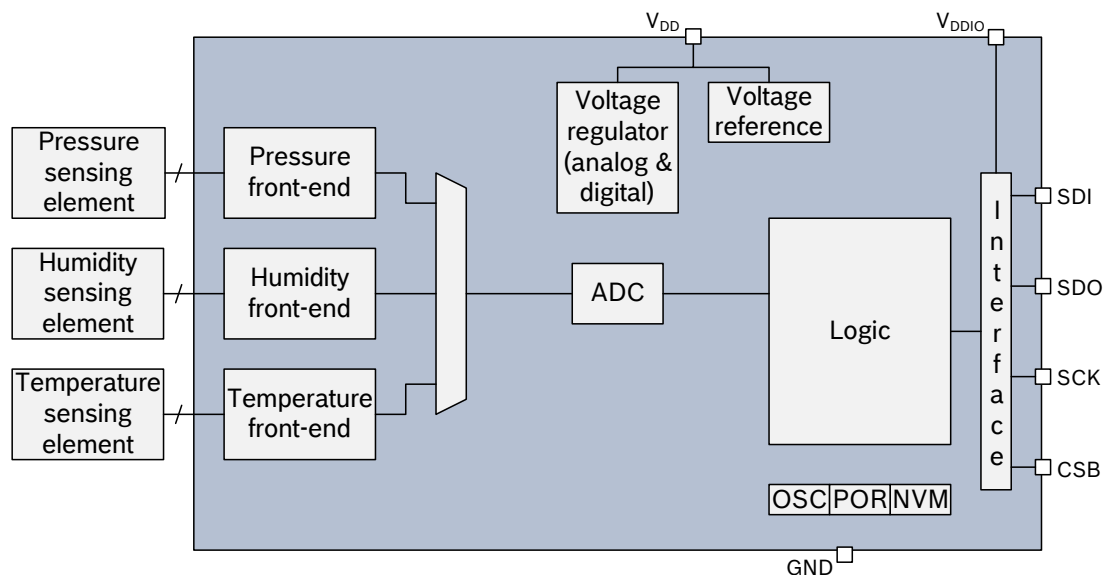

Figure 2: Block diagram of BME280

3.2 Power management

The BME280 has two distinct power supply pins

- V_{DD} is the main power supply for all internal analog and digital functional blocks
- V_{DDIO} is a separate power supply pin used for the supply of the digital interface

A power-on reset (POR) generator is built in; it resets the logic part and the register values after both V_{DD} and V_{DDIO} reach their minimum levels. There are no limitations on slope and sequence

of raising the V_{DD} and V_{DDIO} levels. After powering up, the sensor settles in sleep mode (described in chapter 3.3.2).

It is prohibited to keep any interface pin (SDI, SDO, SCK or CSB) at a logical high level when V_{DDIO} is switched off. Such a configuration can permanently damage the device due an excessive current flow through the ESD protection diodes.

If V_{DDIO} is supplied, but V_{DD} is not, the interface pins are kept at a high-Z level. The bus can therefore already be used freely before the BME280 V_{DD} supply is established.

Resetting the sensor is possible by cycling V_{DD} level or by writing a soft reset command. Cycling the V_{DDIO} level will not cause a reset.

3.3 Sensor modes

The BME280 offers three sensor modes: sleep mode, forced mode and normal mode. These can be selected using the *mode*[1:0] setting (see chapter 5.4.5). The available modes are:

- Sleep mode: no operation, all registers accessible, lowest power, selected after startup
- Forced mode: perform one measurement, store results and return to sleep mode
- Normal mode: perpetual cycling of measurements and inactive periods.

The modes will be explained in detail in chapters 3.3.2 (sleep mode), 3.3.3 (forced mode) and 3.3.4 (normal mode).

3.3.1 Sensor mode transitions

The supported mode transitions are shown in Figure 3. If the device is currently performing a measurement, execution of mode switching commands is delayed until the end of the currently running measurement period. Further mode change commands or other write commands to the register *ctrl_hum* are ignored until the mode change command has been executed. Mode transitions other than the ones shown below are tested for stability but do not represent recommended use of the device.

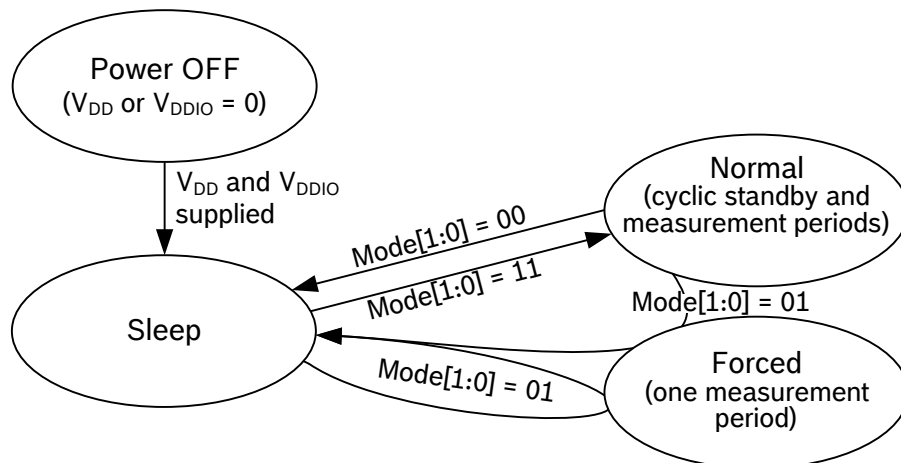

Figure 3: Sensor mode transition diagram

3.3.2 Sleep mode

Sleep mode is entered by default after power on reset. In sleep mode, no measurements are performed and power consumption (I_{DDSM}) is at a minimum. All registers are accessible; Chip-ID and compensation coefficients can be read. There are no special restrictions on interface timings.

3.3.3 Forced mode

In forced mode, a single measurement is performed in accordance to the selected measurement and filter options. When the measurement is finished, the sensor returns to sleep mode and the measurement results can be obtained from the data registers. For a next measurement, forced mode needs to be selected again. This is similar to BMP180 operation. Using forced mode is recommended for applications which require low sampling rate or host-based synchronization. The timing diagram is shown below.

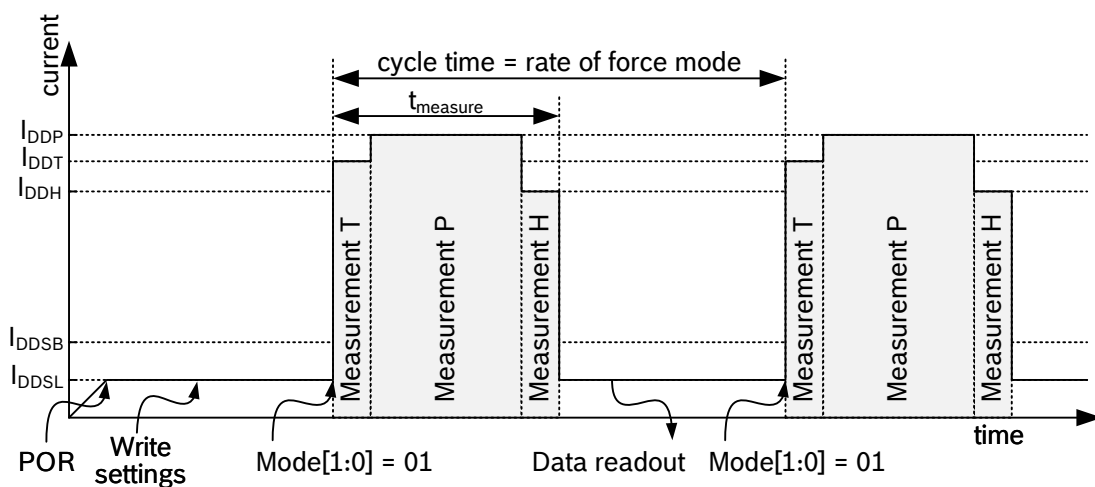

Figure 4: Forced mode timing diagram

3.3.4 Normal mode

Normal mode comprises an automated perpetual cycling between an (active) measurement period and an (inactive) standby period.

The measurements are performed in accordance to the selected measurement and filter options. The standby time is determined by the setting $t_{sb}[2:0]$ and can be set to between 0.5 and 1000 ms according to Table 27.

The total cycle time depends on the sum of the active time (see chapter 9) and standby time $t_{standby}$. The current in the standby period (I_{DDSB}) is slightly higher than in sleep mode. After setting the measurement and filter options and enabling normal mode, the last measurement results can always be obtained at the data registers without the need of further write accesses.

Using normal mode is recommended when using the IIR filter. This is useful for applications in which short-term disturbances (e.g. blowing into the sensor) should be filtered. The timing diagram is shown below:

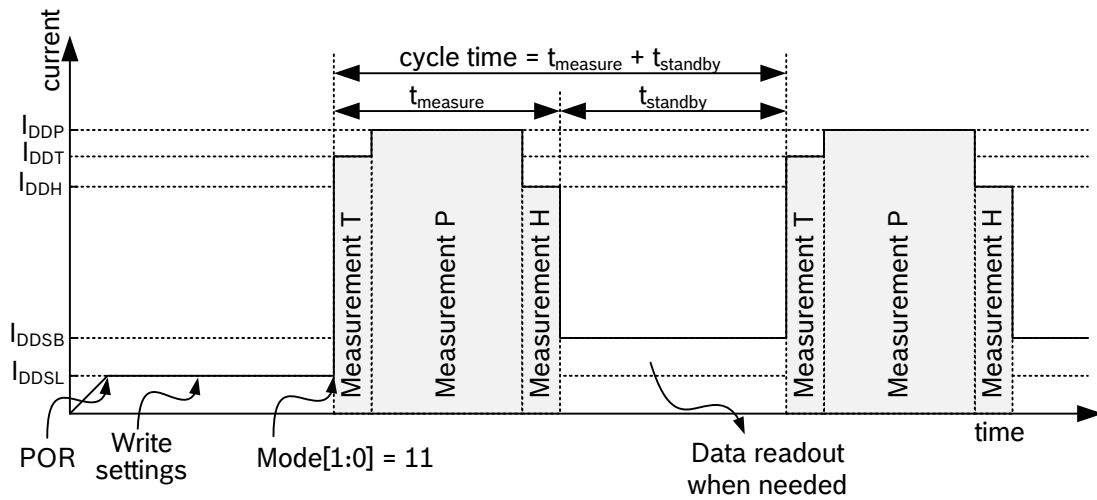

Figure 5: Normal mode timing diagram

3.4 Measurement flow

The BME280 measurement period consists of a temperature, pressure and humidity measurement with selectable oversampling. After the measurement period, the pressure and temperature data can be passed through an optional IIR filter, which removes short-term fluctuations in pressure (e.g. caused by slamming a door). For humidity, such a filter is not needed and has not been implemented. The flow is depicted in the diagram below.

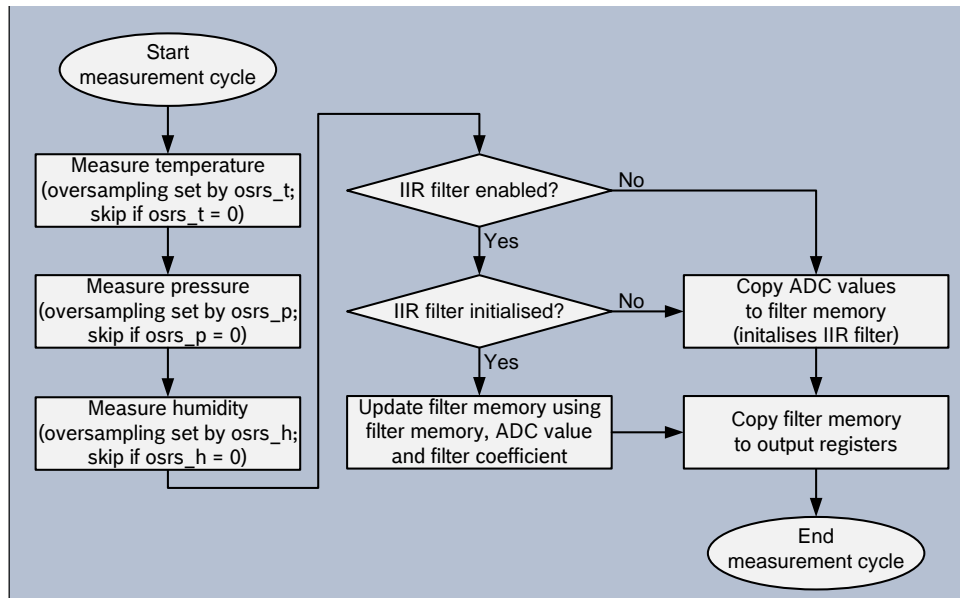

Figure 6: BME280 measurement cycle

The individual blocks of the diagram above will be detailed in the following subchapters.

3.4.1 Humidity measurement

The humidity measurement can be enabled or skipped. When enabled, several oversampling options exist. The humidity measurement is controlled by the *osrs_h[2:0]* setting, which is detailed in chapter 5.4.3. For the humidity measurement, oversampling is possible to reduce the noise. The resolution of the humidity measurement is fixed at 16 bit ADC output.

3.4.2 Pressure measurement

Pressure measurement can be enabled or skipped. When enabled, several oversampling options exist. The pressure measurement is controlled by the *osrs_p[2:0]* setting which is detailed in chapter 5.4.5. For the pressure measurement, oversampling is possible to reduce the noise. The resolution of the pressure data depends on the IIR filter (see chapter 3.4.4) and the oversampling setting (see chapter 5.4.5):

- When the IIR filter is enabled, the pressure resolution is 20 bit.
- When the IIR filter is disabled, the pressure resolution is $16 + (osrs_p - 1)$ bit, e.g. 18 bit when *osrs_p* is set to '3'.

3.4.3 Temperature measurement

Temperature measurement can be enabled or skipped. Skipping the measurement could be useful to measure pressure extremely rapidly. When enabled, several oversampling options exist. The temperature measurement is controlled by the *osrs_t[2:0]* setting which is detailed in chapter 5.4.5. For the temperature measurement, oversampling is possible to reduce the noise. The resolution of the temperature data depends on the IIR filter (see chapter 3.4.4) and the oversampling setting (see chapter 5.4.5):

- When the IIR filter is enabled, the temperature resolution is 20 bit.
- When the IIR filter is disabled, the temperature resolution is $16 + (osrs_t - 1)$ bit, e.g. 18 bit when *osrs_t* is set to '3'.

3.4.4 IIR filter

The humidity value inside the sensor does not fluctuate rapidly and does not require low pass filtering. However, the environmental pressure is subject to many short-term changes, caused e.g. by slamming of a door or window, or wind blowing into the sensor. To suppress these disturbances in the output data without causing additional interface traffic and processor work load, the BME280 features an internal IIR filter. It effectively reduces the bandwidth of the temperature and pressure output signals¹⁰ and increases the resolution of the pressure and temperature output data to 20 bit. The output of a next measurement step is filtered using the following formula:

$$data_filtered = \frac{data_filtered_old \cdot (filter_coefficient - 1) + data_ADC}{filter_coefficient}$$

Data_filtered_old is the data coming from the current filter memory, and *data_ADC* is the data coming from current ADC acquisition. *Data_filtered* is the new value of filter memory and the value that will be sent to the output registers.

The IIR filter can be configured to different filter coefficients, which slows down the response to the sensor inputs. Note that the response time with enabled IIR filter depends on the number of

¹⁰ Since the BME280 does not sample continuously, filtering can suffer from signals with a frequency higher than the sampling rate of the sensor. E.g. environmental fluctuations caused by windows being opened and closed might have a frequency <5 Hz. Consequently, a sampling rate of ODR = 10 Hz is sufficient to obey the Nyquist theorem.

samples generated, which means that the data output rate must be known to calculate the actual response time. For register configuration, please refer to Table 28. A sample response time calculation is shown in chapter 9.4.

Table 6: *filter* settings

Filter coefficient	Samples to reach $\geq 75\%$ of step response
Filter off	1
2	2
4	5
8	11
16	22

In order to find a suitable setting for *filter*, please consult chapter 3.5.

When writing to the register *filter*, the filter is reset. The next ADC values will be passed through the filter unchanged and become the initial memory values for the filter. If temperature or pressure measurements are skipped, the corresponding filter memory will be kept unchanged even though the output registers are set to 0x80000. When the previously skipped measurement is re-enabled, the output will be filtered using the filter memory from the last time when the measurement was not skipped. If this is not desired, please write to the *filter* register in order to re-initialize the filter.

The step response (e.g. response to a sudden change in height) of the different filter settings is displayed in Figure 7.

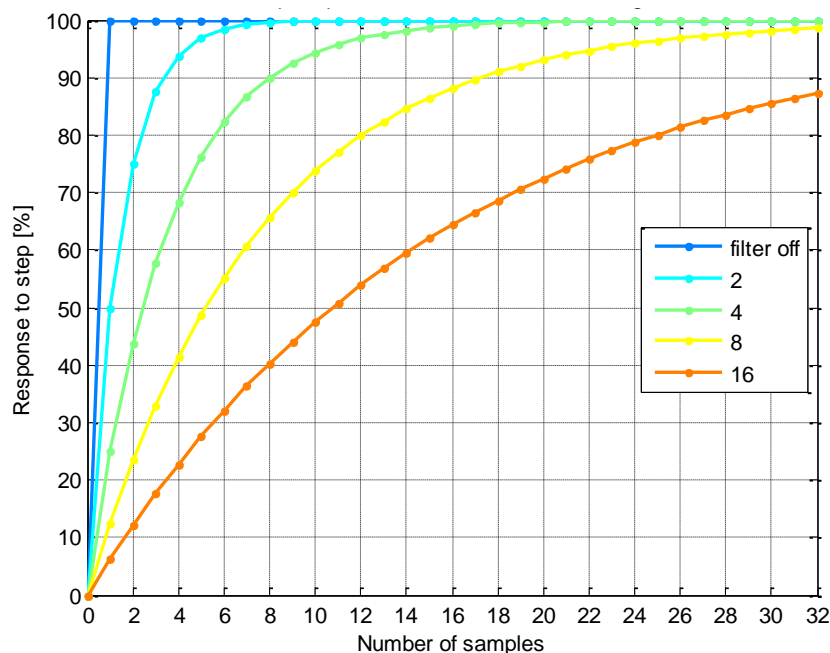

Figure 7: Step response at different IIR filter settings

3.5 Recommended modes of operation

The different oversampling options, filter settings and sensor modes result in a large number of possible settings. In this chapter, a number of settings recommended for various scenarios are presented.

3.5.1 Weather monitoring

Description: Only a very low data rate is needed. Power consumption is minimal. Noise of pressure values is of no concern. Humidity, pressure and temperature are monitored.

Table 7: Settings and performance for weather monitoring

Suggested settings for weather monitoring	
Sensor mode	forced mode, 1 sample / minute
Oversampling settings	pressure ×1, temperature ×1, humidity ×1
IIR filter settings	filter off
Performance for suggested settings	
Current consumption	0.16 µA
RMS Noise	3.3 Pa / 30 cm, 0.07 %RH
Data output rate	1/60 Hz

3.5.2 Humidity sensing

Description: A low data rate is needed. Power consumption is minimal. Forced mode is used to minimize power consumption and to synchronize readout, but using normal mode would also be possible.

Table 8: Settings and performance for humidity sensing

Suggested settings for weather monitoring	
Sensor mode	forced mode, 1 sample / second
Oversampling settings	pressure ×0, temperature ×1, humidity ×1
IIR filter settings	filter off
Performance for suggested settings	
Current consumption	2.9 µA
RMS Noise	0.07 %RH
Data output rate	1 Hz

3.5.3 Indoor navigation

Lowest possible altitude noise is needed. A very low bandwidth is preferred. Increased power consumption is tolerated. Humidity is measured to help detect room changes. This setting is suggested for the Android settings 'SENSOR_DELAY_NORMAL' and 'SENSOR_DELAY_UI'.

Table 9: Settings and performance for indoor navigation

Suggested settings for indoor navigation	
Sensor mode	normal mode, $t_{\text{standby}} = 0.5 \text{ ms}$
Oversampling settings	pressure $\times 16$, temperature $\times 2$, humidity $\times 1$
IIR filter settings	filter coefficient 16
Performance for suggested settings	
Current consumption	633 μA
RMS Noise	0.2 Pa / 1.7 cm
Data output rate	25Hz
Filter bandwidth	0.53 Hz
Response time (75%)	0.9 s

3.5.4 Gaming

Low altitude noise is needed. The required bandwidth is $\sim 2 \text{ Hz}$ in order to respond quickly to altitude changes (e.g. be able to dodge a flying monster in a game). Increased power consumption is tolerated. Humidity sensor is disabled. This setting is suggested for the Android settings 'SENSOR_DELAY_GAMING' and 'SENSOR_DELAY_FASTEST'.

Table 10: Settings and performance for gaming

Suggested settings for gaming	
Sensor mode	normal mode, $t_{\text{standby}} = 0.5 \text{ ms}$
Oversampling settings	pressure $\times 4$, temperature $\times 1$, humidity $\times 0$
IIR filter settings	filter coefficient 16
Performance for suggested settings	
Current consumption	581 μA
RMS Noise	0.3 Pa / 2.5 cm
Data output rate	83 Hz
Filter bandwidth	1.75 Hz
Response time (75%)	0.3 s

3.6 Noise

The noise depends on the oversampling and, for pressure and temperature, on the filter setting used. The stated values were determined in a controlled environment and are based on the average standard deviation of 32 consecutive measurement points taken at highest sampling speed. This is needed in order to exclude long term drifts from the noise measurement. The noise depends both on humidity/pressure oversampling and temperature oversampling, since the temperature value is used for humidity/pressure temperature compensation. The oversampling combinations use below results in an optimal power to noise ratio.

Table 11: Noise and current for humidity

Humidity / temperature oversampling setting	Typical RMS noise in humidity [%RH] at 25 °C	Typ. current [μ A] at 1 Hz forced mode, 25 °C, humidity and temperature measurement, incl. I_{DDSM}
×1 / ×1	0.07	1.8
×2 / ×1	0.05	2.5
×4 / ×1	0.04	3.8
×8 / ×1	0.03	6.5
×16 / ×1	0.02	11.7

Table 12: Noise and current for pressure

Pressure / temperature oversampling setting	Typical RMS noise in pressure [Pa] at 25 °C					Typ. current [μ A] at 1 Hz forced mode, 25 °C, pressure and temperature measurement, incl. I_{DDSM}
	IIR filter coefficient					
	off	2	4	8	16	
×1 / ×1	3.3	1.9	1.2	0.9	0.4	2.8
×2 / ×1	2.6	1.5	1.0	0.6	0.4	4.2
×4 / ×1	2.1	1.2	0.8	0.5	0.3	7.1
×8 / ×1	1.6	1.0	0.6	0.4	0.2	12.8
×16 / ×2	1.3	0.8	0.5	0.4	0.2	24.9

Table 13: Temperature dependence of pressure noise

RMS noise at different temperatures	
Temperature	Typical change in noise compared to 25 °C
-10 °C	+25 %
25 °C	±0 %
75 °C	-5 %

Table 14: Noise in temperature

Temperature oversampling setting	Typical RMS noise in temperature [°C] at 25 °C
×1	0.005
×2	0.004
×4	0.003
×8	0.003
×16	0.002

4. Data readout

To read out data after a conversion, it is **strongly recommended to use a burst read and not address every register individually**. This will prevent a possible mix-up of bytes belonging to different measurements and reduce interface traffic. Note that in I²C mode, even when pressure was not measured, reading the unused registers is faster than reading temperature and humidity data separately.

Data readout is done by starting a burst read from 0xF7 to 0xFC (temperature and pressure) or from **0xF7 to 0xFE (temperature, pressure and humidity)**. The data are read out in an unsigned 20-bit format both for pressure and for temperature and in an unsigned 16-bit format for humidity. It is strongly recommended to use the BME280 API, available from Bosch Sensortec, for readout and compensation. For details on memory map and interfaces, please consult chapters 5 and 6 respectively.

After the uncompensated values for pressure, temperature and humidity 'ut', 'up' and 'uh' have been read, the actual humidity, pressure and temperature needs to be calculated using the compensation parameters stored in the device. The procedure is elaborated in chapter 4.2.

4.1 Data register shadowing

In normal mode, the timing of measurements is not necessarily synchronized to the readout by the user. This means that new measurement results may become available while the user is reading the results from the previous measurement. In this case, shadowing is performed in order to guarantee data consistency. Shadowing will only work if all data registers are read in a single burst read. Therefore, the user must use burst reads if he does not synchronize data readout with the measurement cycle. Using several independent read commands may result in inconsistent data.

If a new measurement is finished and the data registers are still being read, the new measurement results are transferred into shadow data registers. The content of shadow registers is transferred into data registers as soon as the user ends the burst read, even if not all data registers were read.

The end of the burst read is marked by the rising edge of CSB pin in SPI case or by the recognition of a stop condition in I²C case. After the end of the burst read, all user data registers are updated at once.

4.2 Output compensation

The BME280 output consists of the ADC output values. However, each sensing element behaves differently. Therefore, the actual pressure and temperature must be calculated using a set of calibration parameters. In this chapter, the method to read out the trimming values will be given. The recommended calculation uses fixed point arithmetic and is given in chapter 4.2.3.

In high-level languages like Matlab™ or LabVIEW™, fixed-point code may not be well supported. In this case the floating-point code in appendix 8.1 can be used as an alternative.

For 8-bit micro controllers, the variable size may be limited. In this case a simplified 32 bit integer code with reduced accuracy is given in appendix 8.2.

4.2.1 Computational requirements

In the table below an overview is given for the number of clock cycles needed for compensation on a 32 bit Cortex-M3 micro controller with GCC optimization level -O2. This controller does not feature a floating point unit, thus all floating-point calculations are emulated. Floating point is only recommended for PC application, where an FPU is present and these calculations are performed drastically faster.

Table 15: Computational requirements for compensation formulas

Compensation of	Number of clocks (ARM Cortex-M3)		
	32 bit integer	64 bit integer	Double precision
Humidity	~83	–	~2900 ¹¹
Temperature	~46	–	~2400 ¹¹
Pressure	~112 ¹²	~1400	~5400 ¹¹

4.2.2 Trimming parameter readout

The trimming parameters are programmed into the devices' non-volatile memory (NVM) during production and cannot be altered by the customer. Each compensation word is a 16-bit signed or unsigned integer value stored in two's complement. As the memory is organized into 8-bit words, two words must always be combined in order to represent the compensation word. The 8-bit registers are named calib00...calib41 and are stored at memory addresses 0x88...0xA1 and 0xE1...0xE7. The corresponding compensation words are named dig_T# for temperature compensation related values, dig_P# for pressure related values and dig_H# for humidity related values. The mapping is seen in Table 16.

Table 16: Compensation parameter storage, naming and data type

Register Address	Register content	Data type
0x88 / 0x89	dig_T1 [7:0] / [15:8]	unsigned short
0x8A / 0x8B	dig_T2 [7:0] / [15:8]	signed short
0x8C / 0x8D	dig_T3 [7:0] / [15:8]	signed short
0x8E / 0x8F	dig_P1 [7:0] / [15:8]	unsigned short
0x90 / 0x91	dig_P2 [7:0] / [15:8]	signed short
0x92 / 0x93	dig_P3 [7:0] / [15:8]	signed short
0x94 / 0x95	dig_P4 [7:0] / [15:8]	signed short
0x96 / 0x97	dig_P5 [7:0] / [15:8]	signed short
0x98 / 0x99	dig_P6 [7:0] / [15:8]	signed short
0x9A / 0x9B	dig_P7 [7:0] / [15:8]	signed short
0x9C / 0x9D	dig_P8 [7:0] / [15:8]	signed short
0x9E / 0x9F	dig_P9 [7:0] / [15:8]	signed short
0xA1	dig_H1 [7:0]	unsigned char
0xE1 / 0xE2	dig_H2 [7:0] / [15:8]	signed short
0xE3	dig_H3 [7:0]	unsigned char

¹¹ Use only recommended for high-level programming languages like Matlab™ or LabVIEW™

¹² Use only recommended for 8-bit micro controllers

0xE4 / 0xE5[3:0]	dig_H4 [11:4] / [3:0]	signed short
0xE5[7:4] / 0xE6	dig_H5 [3:0] / [11:4]	signed short
0xE7	dig_H6	signed char

4.2.3 Compensation formulas

Please note that it is strongly advised to use the API available from Bosch Sensortec to perform readout and compensation. If this is not wanted, the code below can be applied at the user's risk. Both pressure and temperature values are expected to be received in 20 bit format, positive, stored in a 32 bit signed integer. Humidity is expected to be received in 16 bit format, positive, stored in a 32 bit signed integer.

The variable `t_fine` (signed 32 bit) carries a fine resolution temperature value over to the pressure and humidity compensation formula and could be implemented as a global variable.

The data type "BME280_S32_t" should define a 32 bit signed integer variable type and can usually be defined as "long signed int".

The data type "BME280_U32_t" should define a 32 bit unsigned integer variable type and can usually be defined as "long unsigned int".

For best possible calculation accuracy in pressure, 64 bit integer support is needed. If this is not possible on your platform, please see appendix 8.2 for a 32 bit alternative.

The data type "BME280_S64_t" should define a 64 bit signed integer variable type, which on most supporting platforms can be defined as "long long signed int". The revision of the code is rev.1.1.

```
// Returns temperature in DegC, resolution is 0.01 DegC. Output value of "5123" equals 51.23 DegC.
// t_fine carries fine temperature as global value
BME280_S32_t t_fine;
BME280_S32_t BME280_compensate_T_int32(BME280_S32_t adc_T)
{
    BME280_S32_t var1, var2, T;
    var1 = (((adc_T >> 3) - ((BME280_S32_t)dig_T1 << 1)) * ((BME280_S32_t)dig_T2)) >> 11;
    var2 = (((((adc_T >> 4) - ((BME280_S32_t)dig_T1)) * ((adc_T >> 4) - ((BME280_S32_t)dig_T1))) >> 12) *
        ((BME280_S32_t)dig_T3)) >> 14;
    t_fine = var1 + var2;
    T = (t_fine * 5 + 128) >> 8;
    return T;
}

// Returns pressure in Pa as unsigned 32 bit integer in Q24.8 format (24 integer bits and 8 fractional bits).
// Output value of "24674867" represents 24674867/256 = 96386.2 Pa = 963.862 hPa
BME280_U32_t BME280_compensate_P_int64(BME280_S32_t adc_P)
{
    BME280_S64_t var1, var2, p;
    var1 = ((BME280_S64_t)t_fine) - 128000;
    var2 = var1 * var1 * (BME280_S64_t)dig_P6;
    var2 = var2 + ((var1 * (BME280_S64_t)dig_P5) << 17);
    var2 = var2 + (((BME280_S64_t)dig_P4) << 35);
    var1 = ((var1 * var1 * (BME280_S64_t)dig_P3) >> 8) + ((var1 * (BME280_S64_t)dig_P2) << 12);
    var1 = (((((BME280_S64_t)1) << 47) + var1) * ((BME280_S64_t)dig_P1)) >> 33;
    if (var1 == 0)
    {
        return 0; // avoid exception caused by division by zero
    }
    p = 1048576 - adc_P;
    p = (((p << 31) - var2) * 3125) / var1;
    var1 = (((BME280_S64_t)dig_P9) * (p >> 13) * (p >> 13)) >> 25;
    var2 = (((BME280_S64_t)dig_P8) * p) >> 19;
    p = ((p + var1 + var2) >> 8) + (((BME280_S64_t)dig_P7) << 4);
    return (BME280_U32_t)p;
}

// Returns humidity in %RH as unsigned 32 bit integer in Q22.10 format (22 integer and 10 fractional bits).
// Output value of "47445" represents 47445/1024 = 46.333 %RH
BME280_U32_t bme280_compensate_H_int32(BME280_S32_t adc_H)
{
    BME280_S32_t v_x1_u32r;

    v_x1_u32r = (t_fine - ((BME280_S32_t)76800));
    v_x1_u32r = (((((adc_H << 14) - ((BME280_S32_t)dig_H4) << 20) - ((BME280_S32_t)dig_H5) * v_x1_u32r)) +
        ((BME280_S32_t)16384)) >> 15) * ((((((v_x1_u32r * ((BME280_S32_t)dig_H6)) >> 10) * ((v_x1_u32r *

```

```

        ((BME280_S32_t)dig_H3) >> 11) + ((BME280_S32_t)32768)) >> 10) + ((BME280_S32_t)2097152)) *
        ((BME280_S32_t)dig_H2) + 8192) >> 14));
    v_x1_u32r = (v_x1_u32r - (((((v_x1_u32r >> 15) * (v_x1_u32r >> 15)) >> 7) * ((BME280_S32_t)dig_H1)) >> 4));
    v_x1_u32r = (v_x1_u32r < 0 ? 0 : v_x1_u32r);
    v_x1_u32r = (v_x1_u32r > 419430400 ? 419430400 : v_x1_u32r);
    return (BME280_U32_t)(v_x1_u32r>>12);
}
    
```

5. Global memory map and register description

5.1 General remarks

The entire communication with the device is performed by reading from and writing to registers. Registers have a width of 8 bits. There are several registers which are reserved; they should not be written to and no specific value is guaranteed when they are read. For details on the interface, consult chapter 6.

5.2 Register compatibility to BMP280

The BME280 is downward register compatible to the BMP280, which means that the pressure and temperature control and readout is identical to BMP280. However, the following exceptions have to be considered:

Table 17: Register incompatibilities between BMP280 and BME280

Register	Bits	Content	BMP280	BME280
0xD0 "id"	7:0	chip_id	Read value is 0x56 / 0x57 (samples) 0x58 (mass production)	Read value is 0x60
0xF5 "config"	7:5	t_sb	'110': 2000 ms '111': 4000 ms	'110': 10 ms '111': 20 ms
0xF7...0xF9 "press"	19:0	press	Resolution (16...20 bit) depends only on osrs_p	Without filter, resolution depends on osrs_p; when using filter, resolution is always 20 bit
0xFA...0xFC "temp"	19:0	temp	Resolution (16...20 bit) only depends on osrs_t	Without filter, resolution depends on osrs_t; when using filter, resolution is always 20 bit

5.3 Memory map

The memory map is given in Table 18 below. Reserved registers are not shown.

Table 18: Memory map

Register Name	Address	bit7	bit6	bit5	bit4	bit3	bit2	bit1	bit0	Reset state	
hum_lsb	0xFE	hum_lsb<7:0>								0x00	
hum_msb	0xFD	hum_msb<7:0>								0x80	
temp_xlsb	0xFC	temp_xlsb<7:4>				0	0	0	0	0	0x00
temp_lsb	0xFB	temp_lsb<7:0>								0x00	
temp_msb	0xFA	temp_msb<7:0>								0x80	
press_xlsb	0xF9	press_xlsb<7:4>				0	0	0	0	0	0x00
press_lsb	0xF8	press_lsb<7:0>								0x00	
press_msb	0xF7	press_msb<7:0>								0x80	
config	0xF5	t_sb[2:0]			filter[2:0]			spi3w_en[0]		0x00	
ctrl_meas	0xF4	osrs_t[2:0]			osrs_p[2:0]			mode[1:0]		0x00	
status	0xF3	measuring[0]					im_update[0]				0x00
ctrl_hum	0xF2	osrs_h[2:0]								0x00	
calib26..calib41	0xE1...0xF0	calibration data								individual	
reset	0xE0	reset[7:0]								0x00	
id	0xD0	chip_id[7:0]								0x60	
calib00..calib25	0x88...0xA1	calibration data								individual	

Registers:	Reserved registers	Calibration data	Control registers	Data registers	Status registers	Chip ID	Reset
Type:	do not change	read only	read / write	read only	read only	read only	write only

5.4 Register description

5.4.1 Register 0xD0 “id”

The “id” register contains the chip identification number chip_id[7:0], which is 0x60. This number can be read as soon as the device finished the power-on-reset.

5.4.2 Register 0xE0 “reset”

The “reset” register contains the soft reset word reset[7:0]. If the value 0xB6 is written to the register, the device is reset using the complete power-on-reset procedure. Writing other values than 0xB6 has no effect. The readout value is always 0x00.

5.4.3 Register 0xF2 “ctrl_hum”

The “ctrl_hum” register sets the humidity data acquisition options of the device. **Changes to this register only become effective after a write operation to “ctrl_meas”.**

Table 19: Register 0xF2 “ctrl_hum”

Register 0xF2 “ctrl_hum”	Name	Description
Bit 2, 1, 0	osrs_h[2:0]	Controls oversampling of humidity data. See Table 20 for settings and chapter 3.4.1 for details.

Table 20: register settings osrs_h

osrs_h[2:0]	Humidity oversampling
000	Skipped (output set to 0x8000)
001	oversampling ×1
010	oversampling ×2
011	oversampling ×4
100	oversampling ×8
101, others	oversampling ×16

5.4.4 Register 0xF3 “status”

The “status” register contains two bits which indicate the status of the device.

Table 21: Register 0xF3 “status”

Register 0xF3 “status”	Name	Description
Bit 3	measuring[0]	Automatically set to ‘1’ whenever a conversion is running and back to ‘0’ when the results have been transferred to the data registers.
Bit 0	im_update[0]	Automatically set to ‘1’ when the NVM data are being copied to image registers and back to ‘0’ when the copying is done. The data are copied at power-on-reset and before every conversion.

5.4.5 Register 0xF4 “ctrl_meas”

The “ctrl_meas” register sets the pressure and temperature data acquisition options of the device. The register needs to be written after changing “ctrl_hum” for the changes to become effective.

Table 22: Register 0xF4 “*ctrl_meas*”

Register 0xF4 “ <i>ctrl_meas</i> ”	Name	Description
Bit 7, 6, 5	<i>osrs_t</i> [2:0]	Controls oversampling of temperature data. See Table 24 for settings and chapter 3.4.3 for details.
Bit 4, 3, 2	<i>osrs_p</i> [2:0]	Controls oversampling of pressure data. See Table 23 for settings and chapter 3.4.2 for details.
Bit 1, 0	<i>mode</i> [1:0]	Controls the sensor mode of the device. See Table 25 for settings and chapter 3.3 for details.

 Table 23: register settings *osrs_p*

<i>osrs_p</i> [2:0]	Pressure oversampling
000	Skipped (output set to 0x80000)
001	oversampling ×1
010	oversampling ×2
011	oversampling ×4
100	oversampling ×8
101, others	oversampling ×16

 Table 24: register settings *osrs_t*

<i>osrs_t</i> [2:0]	Temperature oversampling
000	Skipped (output set to 0x80000)
001	oversampling ×1
010	oversampling ×2
011	oversampling ×4
100	oversampling ×8
101, others	oversampling ×16

 Table 25: register settings *mode*

<i>mode</i> [1:0]	Mode
00	Sleep mode
01 and 10	Forced mode
11	Normal mode

5.4.6 Register 0xF5 “*config*”

The “*config*” register sets the rate, filter and interface options of the device. Writes to the “*config*” register in normal mode may be ignored. In sleep mode writes are not ignored.

Table 26: Register 0xF5 “config”

Register 0xF5 “config”	Name	Description
Bit 7, 6, 5	$t_{sb}[2:0]$	Controls inactive duration $t_{standby}$ in normal mode. See Table 27 for settings and chapter 3.3.4 for details.
Bit 4, 3, 2	$filter[2:0]$	Controls the time constant of the IIR filter. See Table 27 for settings and chapter 3.4.4 for details.
Bit 0	$spi3w_en[0]$	Enables 3-wire SPI interface when set to ‘1’. See chapter 6.3 for details.

 Table 27: t_{sb} settings

$t_{sb}[2:0]$	$t_{standby}$ [ms]
000	0.5
001	62.5
010	125
011	250
100	500
101	1000
110	10
111	20

 Table 28: $filter$ settings

$filter[2:0]$	Filter coefficient
000	Filter off
001	2
010	4
011	8
100, others	16

5.4.7 Register 0xF7...0xF9 “press” ($_{msb}$, $_{lsb}$, $_{xlsb}$)

The “press” register contains the raw pressure measurement output data up[19:0]. For details on how to read out the pressure and temperature information from the device, please consult chapter 4.

Table 29: Register 0xF7 ... 0xF9 “*press*”

Register 0xF7...0xF9 “ <i>press</i> ”	Name	Description
0xF7	press_msb[7:0]	Contains the MSB part up[19:12] of the raw pressure measurement output data.
0xF8	press_lsb[7:0]	Contains the LSB part up[11:4] of the raw pressure measurement output data.
0xF9 (bit 7, 6, 5, 4)	press_xlsb[3:0]	Contains the XLSB part up[3:0] of the raw pressure measurement output data. Contents depend on temperature resolution.

5.4.8 Register 0xFA...0xFC “*temp*” (*_msb*, *_lsb*, *_xlsb*)

The “*temp*” register contains the raw temperature measurement output data *ut*[19:0]. For details on how to read out the pressure and temperature information from the device, please consult chapter 4.

 Table 30: Register 0xFA ... 0xFC “*temp*”

Register 0xFA...0xFC “ <i>temp</i> ”	Name	Description
0xFA	temp_msb[7:0]	Contains the MSB part <i>ut</i> [19:12] of the raw temperature measurement output data.
0xFB	temp_lsb[7:0]	Contains the LSB part <i>ut</i> [11:4] of the raw temperature measurement output data.
0xFC (bit 7, 6, 5, 4)	temp_xlsb[3:0]	Contains the XLSB part <i>ut</i> [3:0] of the raw temperature measurement output data. Contents depend on pressure resolution.

5.4.9 Register 0xFD...0xFE “*hum*” (*_msb*, *_lsb*)

The “*temp*” register contains the raw temperature measurement output data *ut*[19:0]. For details on how to read out the pressure and temperature information from the device, please consult chapter 4.

 Table 31: Register 0xFD ... 0xFE “*hum*”

Register 0xFD...0xFE “ <i>hum</i> ”	Name	Description
0xFD	hum_msb[7:0]	Contains the MSB part <i>uh</i> [15:8] of the raw humidity measurement output data.
0xFE	temp_lsb[7:0]	Contains the LSB part <i>uh</i> [7:0] of the raw humidity measurement output data.

6. Digital interfaces

The BME280 supports the I²C and SPI digital interfaces; **it acts as a slave for both protocols.** The I²C interface supports the Standard, Fast and High Speed modes. The SPI interface supports both SPI mode '00' (CPOL = CPHA = '0') and mode '11' (CPOL = CPHA = '1') in 4-wire and 3-wire configuration.

The following transactions are supported:

- Single byte write
- multiple byte write (using pairs of register addresses and register data)
- single byte read
- multiple byte read (using a single register address which is auto-incremented)

6.1 Interface selection

Interface selection is done automatically based on CSB (chip select) status. **If CSB is connected to V_{DDIO}, the I²C interface is active.** If CSB is pulled down, the SPI interface is activated. After CSB has been pulled down once (regardless of whether any clock cycle occurred), the I²C interface is disabled until the next power-on-reset. This is done in order to avoid inadvertently decoding SPI traffic to another slave as I²C data. Since the device startup is deferred until both V_{DD} and V_{DDIO} are established, there is no risk of incorrect protocol detection because of the power-up sequence used. However, if I²C is to be used and CSB is not directly connected to V_{DDIO} but is instead connected to a programmable pin, it must be ensured that this pin already outputs the V_{DDIO} level during power-on-reset of the device. If this is not the case, the device will be locked in SPI mode and not respond to I²C commands.

6.2 I²C Interface

The I²C slave interface is compatible with Philips I²C Specification version 2.1. For detailed timings, please review Table 33. All modes (standard, fast, high speed) are supported. SDA and SCL are not pure open-drain. Both pads contain ESD protection diodes to V_{DDIO} and GND. As the device does not perform clock stretching, the SCL structure is a high-Z input without drain capability.

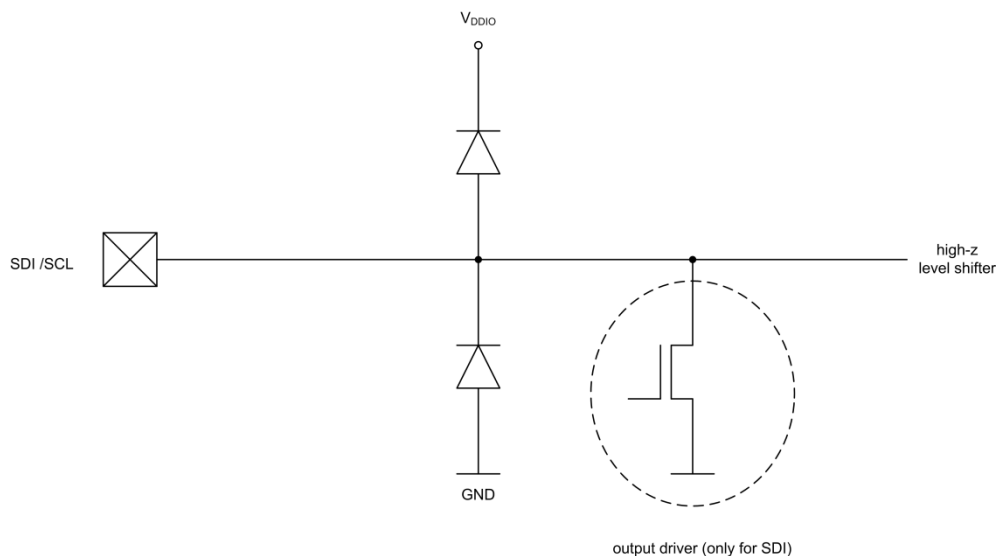

Figure 8: SDI/SCK ESD drawing

The 7-bit device address is 111011x. The 6 MSB bits are fixed. The last bit is changeable by SDO value and can be changed during operation. Connecting SDO to GND results in slave address 1110110 (0x76); connection it to V_{DDIO} results in slave address 1110111 (0x77), which is the same as BMP280's I²C address. The SDO pin cannot be left floating; if left floating, the I²C address will be undefined.

The I²C interface uses the following pins:

- SCK: serial clock (SCL)
- SDI: data (SDA)
- SDO: Slave address LSB (GND = '0', V_{DDIO} = '1')

CSB must be connected to V_{DDIO} to select I²C interface. SDI is bi-directional with open drain to GND: it must be externally connected to V_{DDIO} via a pull up resistor. Refer to chapter 7 for connection instructions.

The following abbreviations will be used in the I²C protocol figures:

- S Start
- P Stop
- ACKS Acknowledge by slave
- ACKM Acknowledge by master
- NACKM Not acknowledge by master

6.2.1 I²C write

Writing is done by sending the slave address in write mode (RW = '0'), resulting in slave address 111011X0 ('X' is determined by state of SDO pin). Then the master sends pairs of register addresses and register data. The transaction is ended by a stop condition. This is depicted in Figure 9.

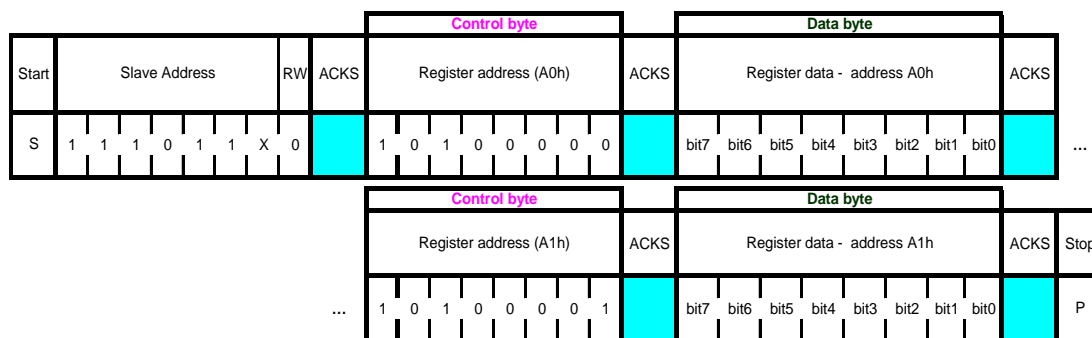
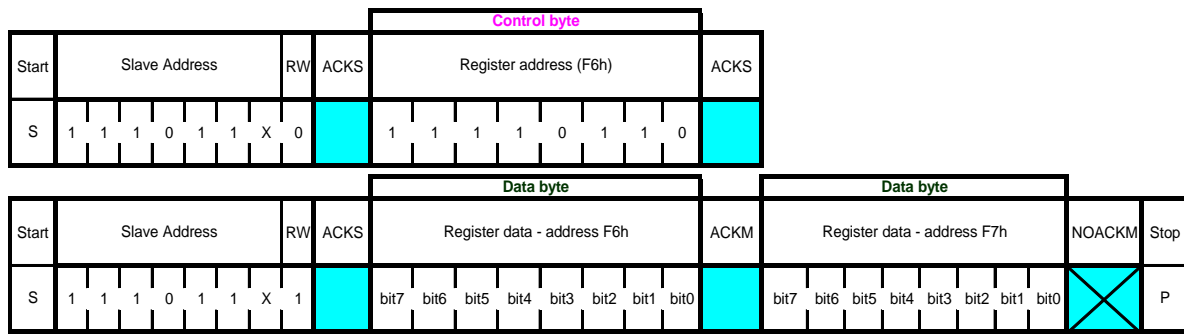

Figure 9: I²C multiple byte write (not auto-incremented)

6.2.2 I²C read

To be able to read registers, first the register address must be sent in write mode (slave address 111011X0). Then either a stop or a repeated start condition must be generated. After this the slave is addressed in read mode (RW = '1') at address 111011X1, after which the slave sends out data from auto-incremented register addresses until a NOACKM and stop condition occurs. This is depicted in Figure 10, where register 0xF6 and 0xF7 are read.

 Figure 10: I²C multiple byte read

6.3 SPI interface

The SPI interface is compatible with SPI mode '00' (CPOL = CPHA = '0') and mode '11' (CPOL = CPHA = '1'). The automatic selection between mode '00' and '11' is determined by the value of SCK after the CSB falling edge.

The SPI interface has two modes: 4-wire and 3-wire. The protocol is the same for both. The 3-wire mode is selected by setting '1' to the register spi3w_en. The pad SDI is used as a data pad in 3-wire mode.

The SPI interface uses the following pins:

- CSB: chip select, active low
- SCK: serial clock
- SDI: serial data input; data input/output in 3-wire mode
- SDO: serial data output; hi-Z in 3-wire mode

Refer to chapter 7 for connection instructions.

CSB is active low and has an integrated pull-up resistor. Data on SDI is latched by the device at SCK rising edge and SDO is changed at SCK falling edge. Communication starts when CSB goes to low and stops when CSB goes to high; during these transitions on CSB, SCK must be stable. The SPI protocol is shown in Figure 11. For timing details, please review Table 34.

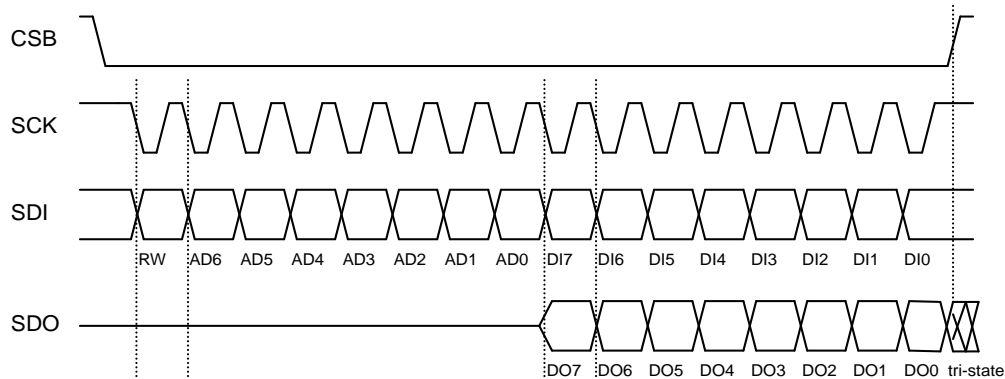

Figure 11: SPI protocol (shown for mode '11' in 4-wire configuration)

In SPI mode, only 7 bits of the register addresses are used; the MSB of register address is not used and replaced by a read/write bit (RW = '0' for write and RW = '1' for read).

Example: address 0xF7 is accessed by using SPI register address 0x77. For write access, the byte 0x77 is transferred, for read access, the byte 0xF7 is transferred.

6.3.1 SPI write

Writing is done by lowering CSB and sending pairs control bytes and register data. The control bytes consist of the SPI register address (= full register address without bit 7) and the write command (bit7 = RW = '0'). Several pairs can be written without raising CSB. The transaction is ended by a raising CSB. The SPI write protocol is depicted in Figure 12.

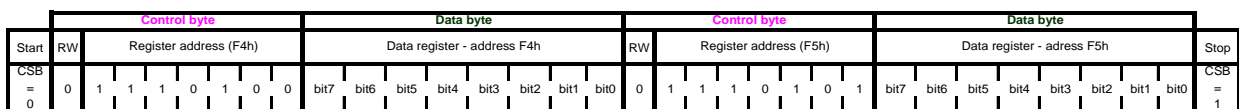

Figure 12: SPI multiple byte write (not auto-incremented)

6.3.2 SPI read

Reading is done by lowering CSB and first sending one control byte. The control bytes consist of the SPI register address (= full register address without bit 7) and the read command (bit 7 = RW = '1'). After writing the control byte, data is sent out of the SDO pin (SDI in 3-wire mode); the register address is automatically incremented. The SPI read protocol is depicted in Figure 13.

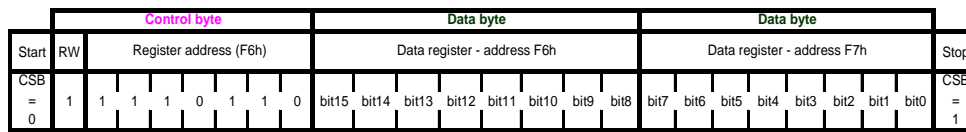

Figure 13: SPI multiple byte read

6.4 Interface parameter specification

6.4.1 General interface parameters

The general interface parameters are given in Table 32 below.

Table 32: interface parameters

Parameter	Symbol	Condition	Min	Typ	Max	Unit
Input low level	V_{il_si}	$V_{DDIO}=1.2\text{ V to }3.6\text{ V}$			20	% V_{DDIO}
Input high level	V_{ih_si}	$V_{DDIO}=1.2\text{ V to }3.6\text{ V}$	80			% V_{DDIO}
Output low level I ² C	V_{ol_SDI}	$V_{DDIO}=1.62\text{ V}, I_{oi}=3\text{ mA}$			20	% V_{DDIO}
Output low level I ² C	$V_{ol_SDI_1.2}$	$V_{DDIO}=1.20\text{ V}, I_{oi}=3\text{ mA}$			23	% V_{DDIO}
Output low level SPI	V_{ol_SDO}	$V_{DDIO}=1.62\text{ V}, I_{oi}=1\text{ mA}$			20	% V_{DDIO}
Output low level SPI	$V_{ol_SDO_1.2}$	$V_{DDIO}=1.20\text{ V}, I_{oi}=1\text{ mA}$			23	% V_{DDIO}
Output high level	V_{oh}	$V_{DDIO}=1.62\text{ V}, I_{oh}=1\text{ mA}$ (SDO, SDI)	80			% V_{DDIO}
Output high level	$V_{oh_1.2}$	$V_{DDIO}=1.20\text{ V}, I_{oh}=1\text{ mA}$ (SDO, SDI)	60			% V_{DDIO}
Pull-up resistor	R_{pull}	Internal CSB pull-up resistance to V_{DDIO}	70	120	190	k Ω
I ² C bus load capacitor	C_b	On SDI and SCK			400	pF

6.4.2 I²C timings

For I²C timings, the following abbreviations are used:

- “S&F mode” = standard and fast mode
- “HS mode” = high speed mode
- C_b = bus capacitance on SDA line

All other naming refers to I²C specification 2.1 (January 2000).

The I²C timing diagram is in Figure 14. The corresponding values are given in Table 33.

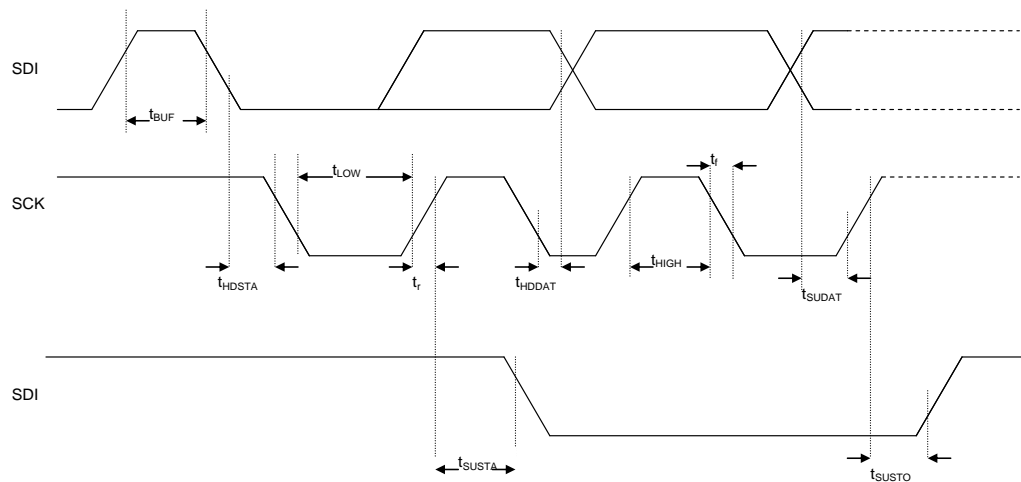

 Figure 14: I²C timing diagram

 Table 33: I²C timings

Parameter	Symbol	Condition	Min	Typ	Max	Unit
SDI setup time	$t_{SU,DATA}$	S&F Mode	160			ns
		HS mode	30			ns
SDI hold time	$t_{HD,DATA}$	S&F Mode, $C_b \leq 100$ pF	80			ns
		S&F Mode, $C_b \leq 400$ pF	90			ns
		HS mode, $C_b \leq 100$ pF	18		115	ns
		HS mode, $C_b \leq 400$ pF	24		150	ns
SCK low pulse	t_{LOW}	HS mode, $C_b \leq 100$ pF $V_{DDIO} = 1.62$ V	160			ns
SCK low pulse	t_{LOW}	HS mode, $C_b \leq 100$ pF $V_{DDIO} = 1.2$ V	210			ns

The above-mentioned I²C specific timings correspond to the following internal added delays:

- Input delay between SDI and SCK inputs: SDI is more delayed than SCK by typically 100 ns in Standard and Fast Modes and by typically 20 ns in High Speed Mode.
- Output delay from SCK falling edge to SDI output propagation is typically 140 ns in Standard and Fast Modes and typically 70 ns in High Speed Mode.

6.4.3 SPI timings

The SPI timing diagram is in Figure 15, while the corresponding values are given in Table 34. All timings apply both to 4- and 3-wire SPI.

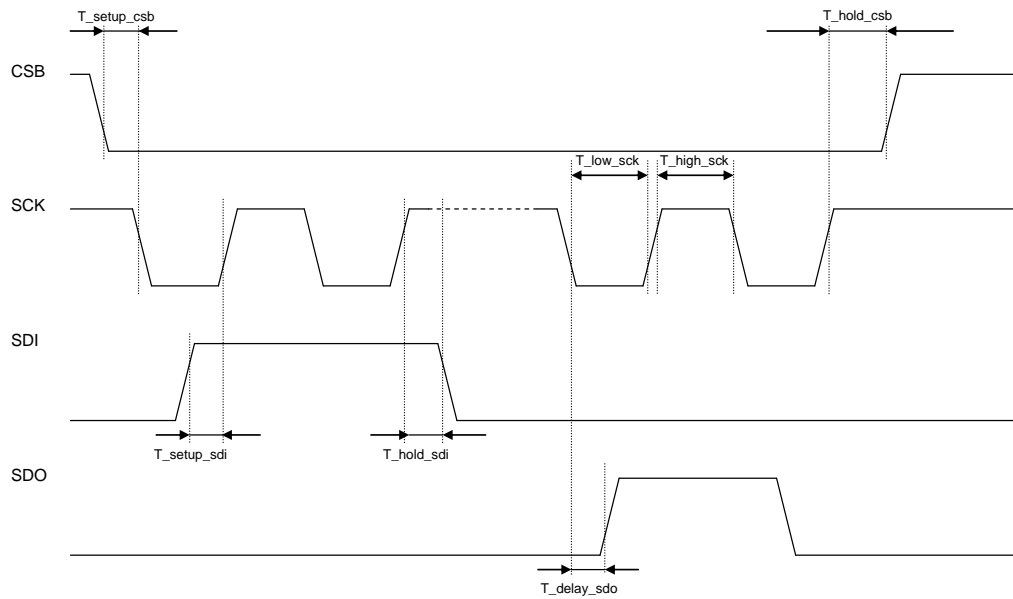

Figure 15: SPI timing diagram

Table 34: SPI timings

Parameter	Symbol	Condition	Min	Typ	Max	Unit
SPI clock input frequency	F_spi		0		10	MHz
SCK low pulse	T_low_sck		20			ns
SCK high pulse	T_high_sck		20			ns
SDI setup time	T_setup_sdi		20			ns
SDI hold time	T_hold_sdi		20			ns
SDO output delay	T_delay_sdo	25 pF load, V _{DDIO} =1.6 V min			30	ns
SDO output delay	T_delay_sdo	25 pF load, V _{DDIO} =1.2 V min			40	ns
CSB setup time	T_setup_csb		20			ns
CSB hold time	T_hold_csb		20			ns

7. Pin-out and connection diagram

7.1 Pin-out

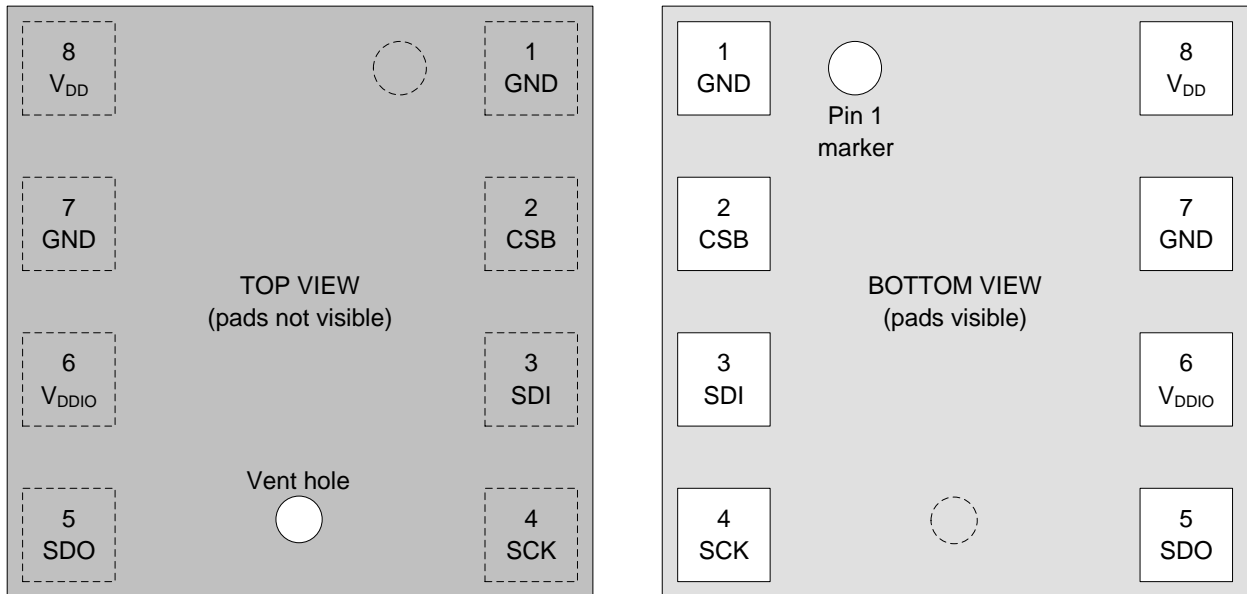

Figure 16: Pin-out top and bottom view

Note: The pin numbering of BME280 is performed in the untypical clockwise direction when seen in top view and counter-clockwise when seen in bottom view.

Table 35: Pin description

Pin	Name	I/O Type	Description	Connect to		
				SPI 4W	SPI 3W	I ² C
1	GND	Supply	Ground	GND		
2	CSB	In	Chip select	CSB	CSB	V _{DDIO}
3	SDI	In/Out	Serial data input	SDI	SDI/SDO	SDA
4	SCK	In	Serial clock input	SCK	SCK	SCL
5	SDO	In/Out	Serial data output	SDO	DNC	GND for default address
6	V _{DDIO}	Supply	Digital / Interface supply	V _{DDIO}		
7	GND	Supply	Ground	GND		
8	V _{DD}	Supply	Analog supply	V _{DD}		

7.2 Connection diagram I²C

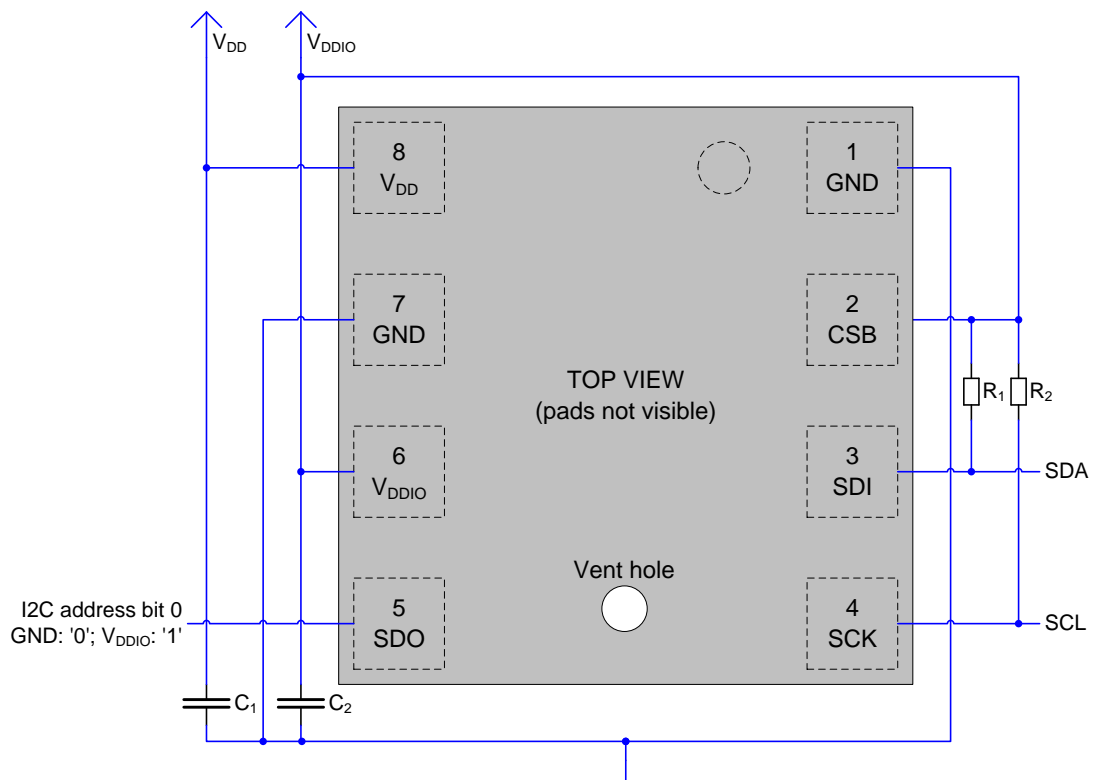

Figure 17: I²C connection diagram

Notes:

- The recommended value for C_1 , C_2 is 100 nF
- The value for the pull-up resistors R_1 , R_2 should be based on the interface timing and the bus load; a normal value is 4.7 k Ω
- A direct connection between CSB and V_{DDIO} is required

7.3 Connection diagram 4-wire SPI

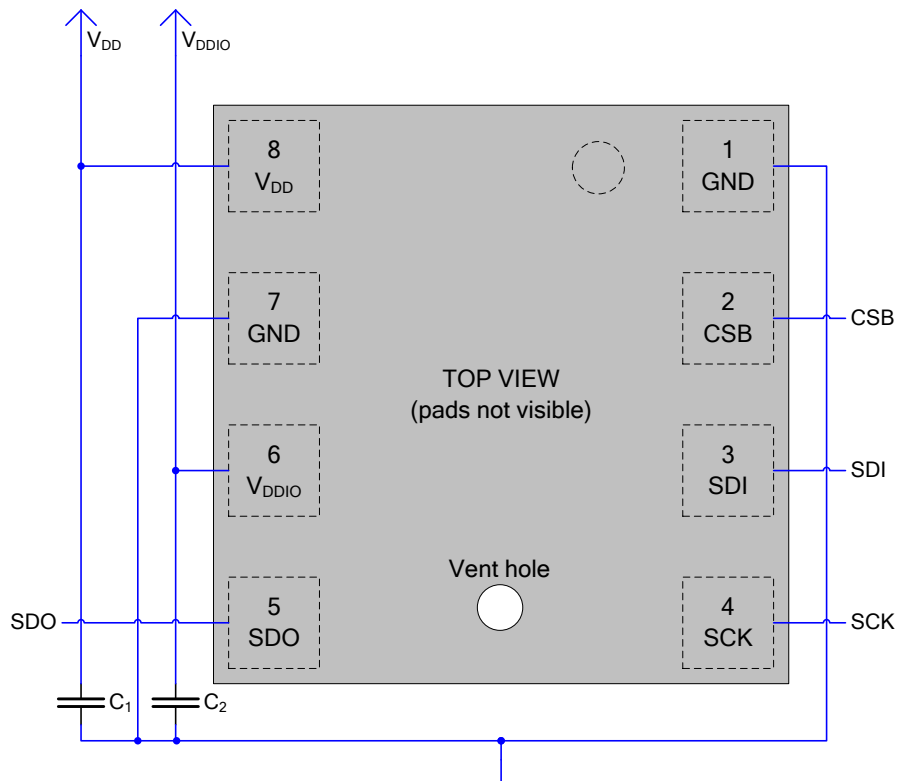

Figure 18: 4-wire SPI connection diagram

Note: The recommended value for C₁, C₂ is 100 nF

7.4 Connection diagram 3-wire SPI

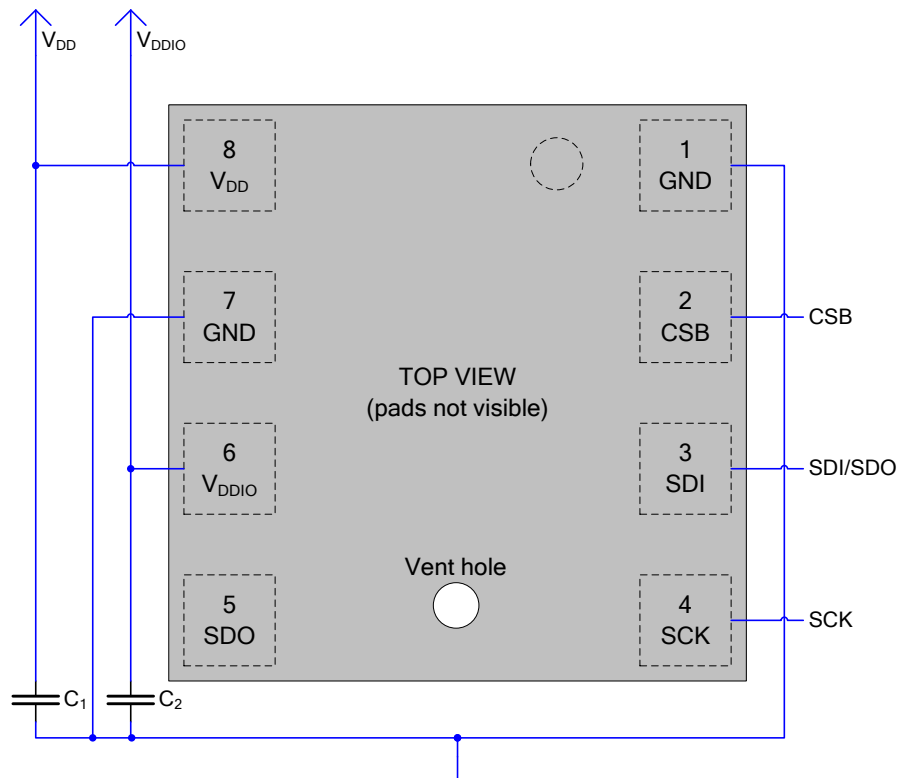
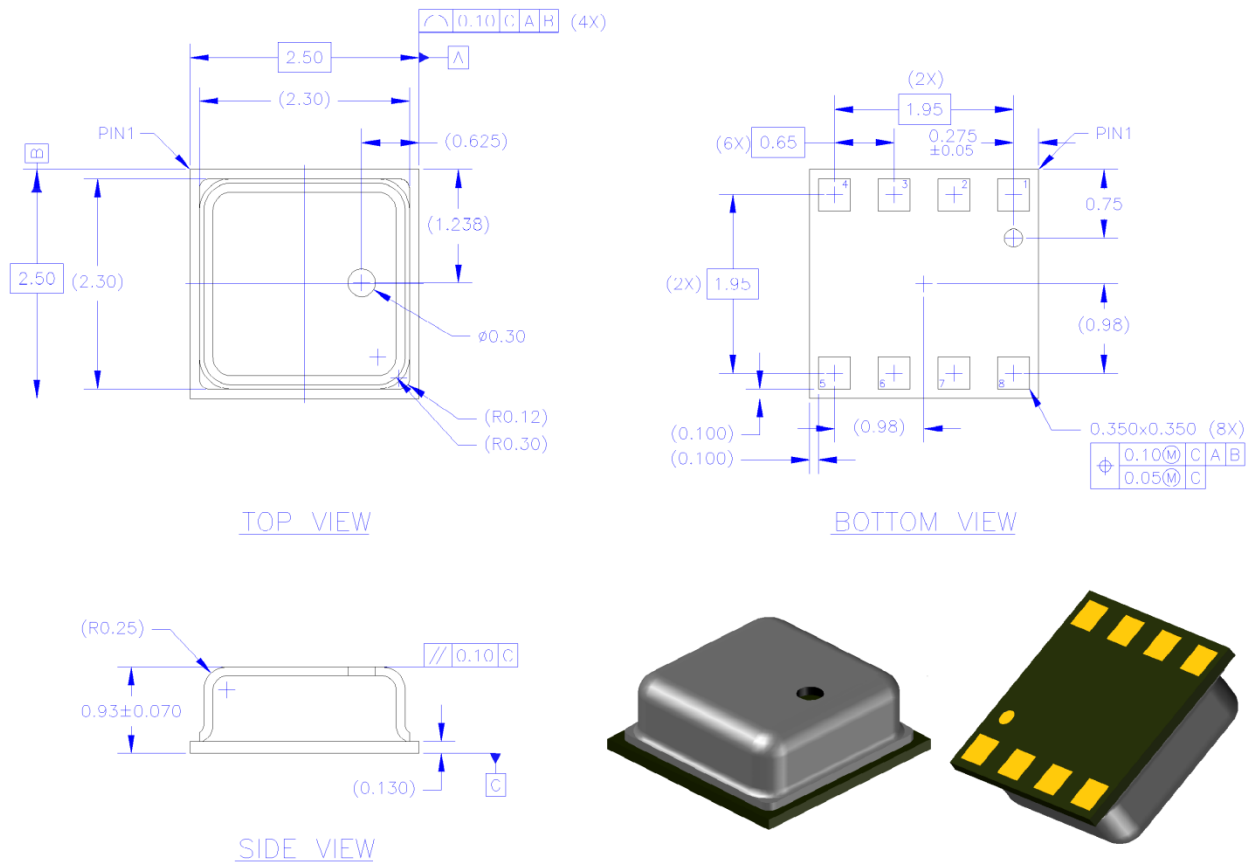

Figure 19: 3-wire SPI connection diagram

Note: The recommended value for C_1 , C_2 is 100 nF

7.5 Package dimensions



PACKAGE TYPE CAVITY MEMS	BODY X 2.50	BODY Y 2.50	BODY Z 1.00(MAX)
LGA PITCH 0.65	LGA SIZE 0.350X0.350	LGA COUNT 8	BALL MATRIX N/A

UNLESS OTHERWISE SPECIFIED
DIMENSIONS ARE IN MILLIMETERS

DECIMAL
X.X ±0.1
X.XX ±0.05
X.XXX ±0.030

ANGULAR
±1°

INTERPRET DIM AND TOL PER
ASME Y14.5M - 1994

Figure 20: Package dimensions for top, bottom and side view

7.6 Landing pattern recommendation

For the design of the landing pattern, the following dimensioning is recommended:

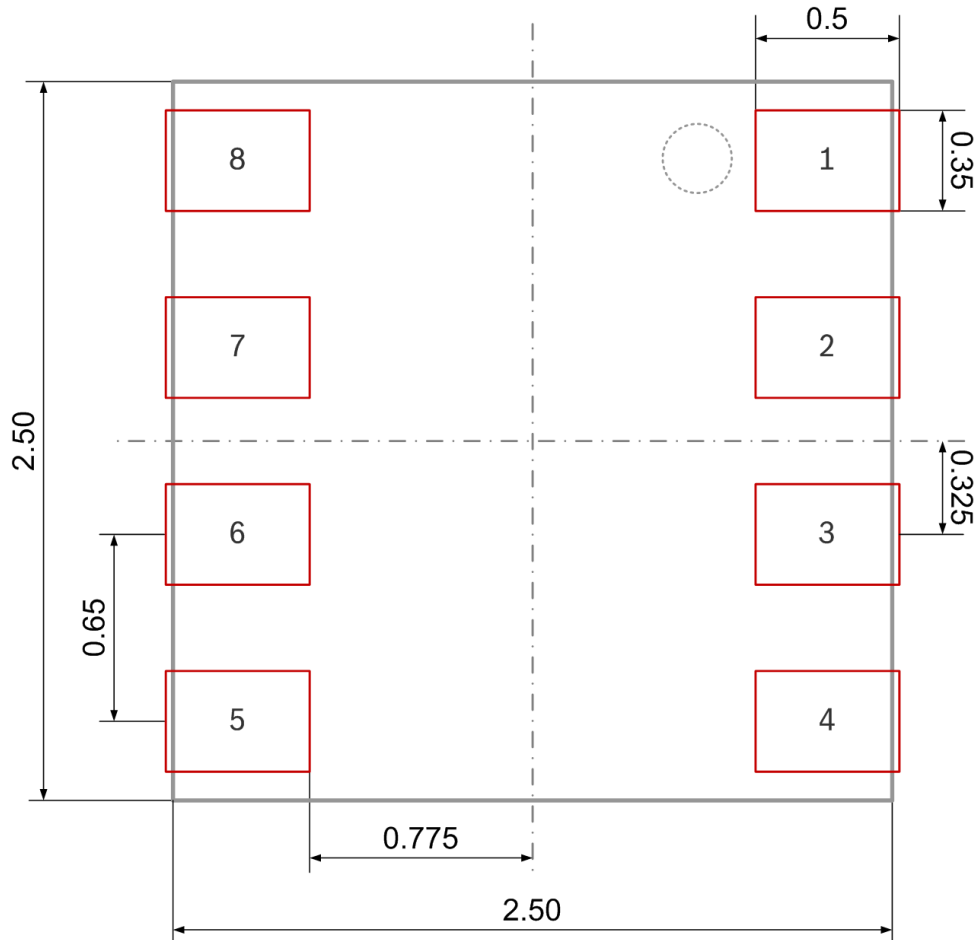

Figure 21: Recommended landing pattern (top view)

Note: red areas demark exposed PCB metal pads.

- In case of a solder mask defined (SMD) PCB process, the land dimensions should be defined by solder mask openings. The underlying metal pads are larger than these openings.
- In case of a non solder mask defined (NSMD) PCB process, the land dimensions should be defined in the metal layer. The mask openings are larger than these metal pads.

7.7 Marking

7.7.1 Mass production devices

Table 36: Marking of mass production parts

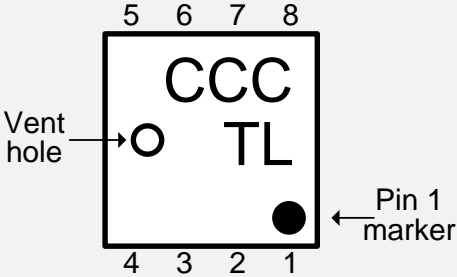
Marking	Symbol	Description
	CCC	<u>Lot counter</u> : 3 alphanumeric digits, variable to generate mass production trace-code
	T	<u>Product number</u> : 1 alphanumeric digit, fixed to identify product type, T = "U" "U" is associated with the product BME280 (part number 0 273 141 185)
	L	<u>Sub-contractor ID</u> : 1 alphanumeric digit, variable to identify sub-contractor (L = "P")

7.7.2 Engineering samples

Table 37: Marking of engineering samples

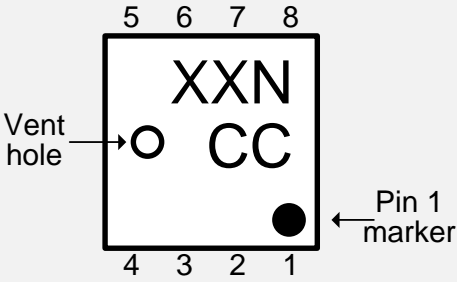
Marking	Symbol	Description
	XX	<u>Sample ID</u> : 2 alphanumeric digits, variable to generate trace-code
	N	<u>Eng. Sample ID</u> : 1 alphanumeric digit, fixed to identify engineering sample, N = “*” or “e” or “E”
	CC	<u>Counter ID</u> : 2 alphanumeric digits, variable to generate trace-code

7.8 Soldering guidelines and reconditioning recommendations

The moisture sensitivity level of the BME280 sensors corresponds to JEDEC Level 1, see also:

- IPC/JEDEC J-STD-020C “Joint Industry Standard: Moisture/Reflow Sensitivity Classification for non-hermetic Solid State Surface Mount Devices”
- IPC/JEDEC J-STD-033A “Joint Industry Standard: Handling, Packing, Shipping and Use of Moisture/Reflow Sensitive Surface Mount Devices”.

The sensor fulfils the lead-free soldering requirements of the above-mentioned IPC/JEDEC standard, i.e. reflow soldering with a peak temperature up to 260°C. The minimum height of the solder after reflow shall be at least 50µm. This is required for good mechanical decoupling between the sensor device and the printed circuit board (PCB).

Profile Feature	Pb-Free Assembly
Average Ramp-Up Rate ($T_{S_{max}}$ to T_p)	3° C/second max.
Preheat – Temperature Min ($T_{S_{min}}$) – Temperature Max ($T_{S_{max}}$) – Time ($t_{S_{min}}$ to $t_{S_{max}}$)	150 °C 200 °C 60-180 seconds
Time maintained above: – Temperature (T_L) – Time (t_L)	217 °C 60-150 seconds
Peak/Classification Temperature (T_p)	260 °C
Time within 5 °C of actual Peak Temperature (t_p)	20-40 seconds
Ramp-Down Rate	6 °C/second max.
Time 25 °C to Peak Temperature	8 minutes max.

Note 1: All temperatures refer to topside of the package, measured on the package body surface.

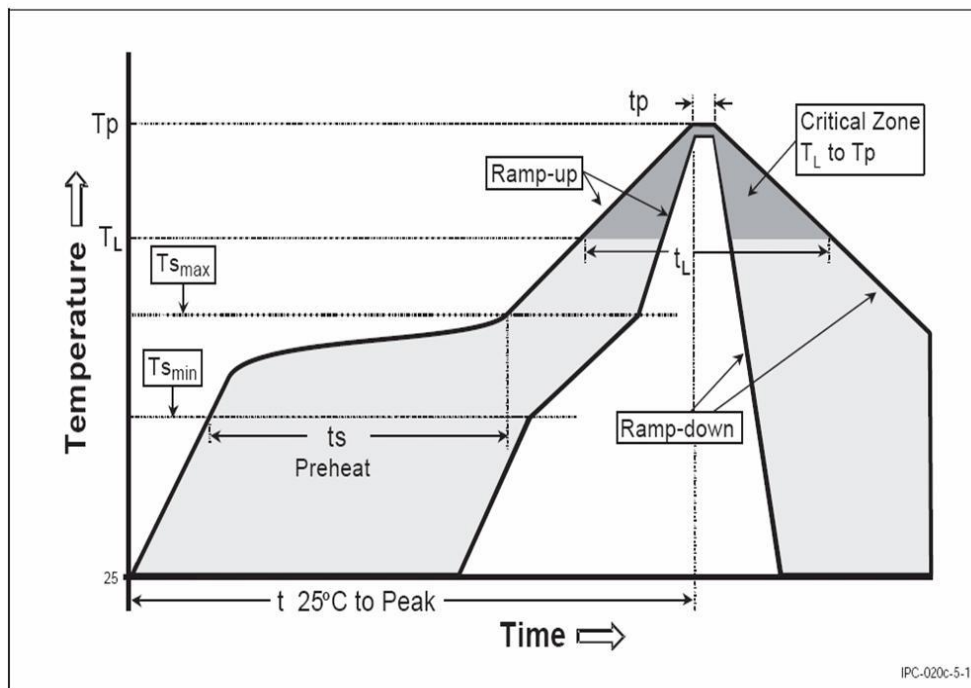

Figure 22: Soldering profile

7.9 Reconditioning Procedure

After exposing the device to operating conditions, which exceed the limits specified in section 1.2, e.g. after reflow, the humidity sensor may possess an additional offset. Therefore the following reconditioning procedure is mandatory to restore the calibration state:

1. Dry-Baking: 120 °C at <5% rH for 2 h
2. Re-Hydration: 70 °C at 75% rH for 6 h

or alternatively

1. Dry-Baking: 120 °C at <5% rH for 2 h
2. Re-Hydration: 25 °C at 75% rH for 24 h

or alternatively after solder reflow only

1. Do not perform Dry-Baking
2. Ambient Re-Hydration: ~25 °C at >40% rH for >5d

7.10 Tape and reel specification

7.10.1 Dimensions

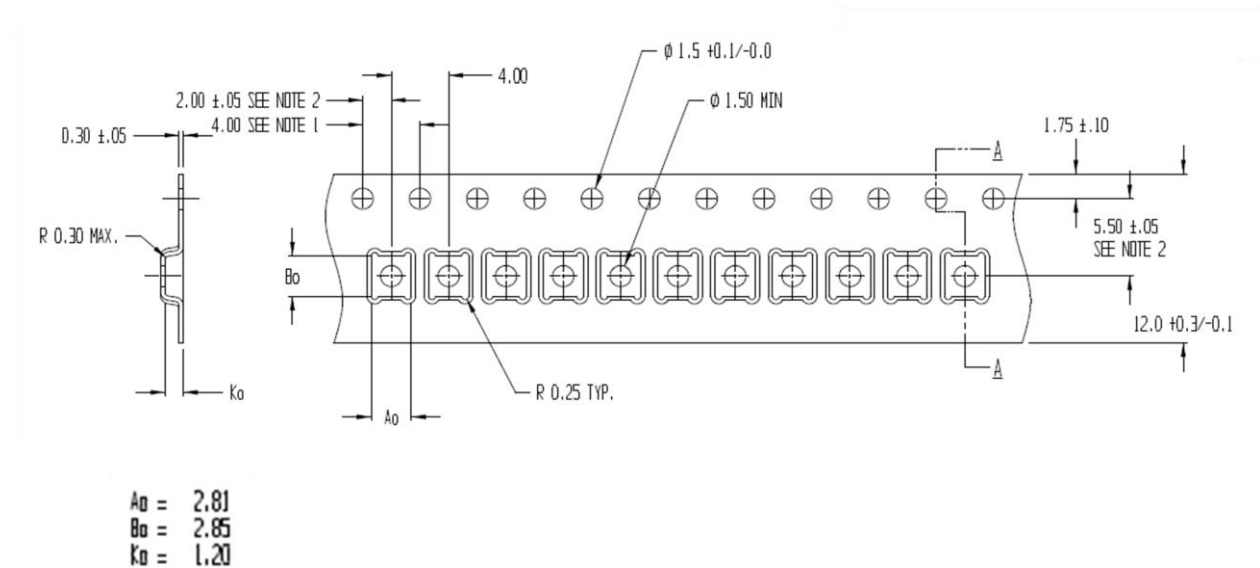

Figure 23: Tape and Reel dimensions

Quantity per reel: 10 kpcs.

7.10.2 Orientation within the reel

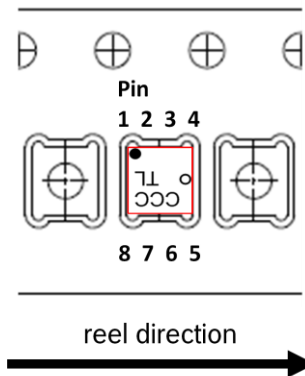

Figure 24: Orientation within tape

7.11 Mounting and assembly recommendations

In order to achieve the specified performance for your design, the following recommendations and the “Handling, soldering & mounting instructions BME280” should be taken into consideration when mounting a pressure sensor on a printed-circuit board (PCB):

- The clearance above the metal lid shall be 0.1mm at minimum.
- For the device housing appropriate venting needs to be provided in case the ambient pressure shall be measured.
- Liquids shall not come into direct contact with the device.
- During operation the sensor chip is sensitive to light, which can influence the accuracy of the measurement (photo-current of silicon). The position of the vent hole minimizes the light exposure of the sensor chip. Nevertheless, Bosch Sensortec recommends avoiding the exposure of BME280 to strong light sources.
- Soldering may not be done using vapor phase processes since the sensor will be damaged by the liquids used in these processes.

7.12 Environmental safety

7.12.1 RoHS

The BME280 sensor meets the requirements of the EC restriction of hazardous substances (RoHS) directive, see also:

Directive 2011/65/EU of the European Parliament and of the Council of 8 June 2011 on the restriction of the use of certain hazardous substances in electrical and electronic equipment.

7.12.2 Halogen content

The BME280 is halogen-free. For more details on the analysis results please contact your Bosch Sensortec representative.

7.12.3 Internal package structure

Within the scope of Bosch Sensortec’s ambition to improve its products and secure the mass product supply, Bosch Sensortec qualifies additional sources (e.g. 2nd source) for the package of the BME280.

While Bosch Sensortec took care that all of the technical packages parameters are described above are 100% identical for all sources, there can be differences in the chemical content and the internal structural between the different package sources.

However, as secured by the extensive product qualification process of Bosch Sensortec, this has no impact to the usage or to the quality of the BME280 product.

8. Appendix A: Alternative compensation formulas

8.1 Compensation formulas in double precision floating point

Please note that it is strongly advised to use the API available from Bosch Sensortec to perform readout and compensation. If this is not wanted, the code below can be applied at the user's risk. Both pressure and temperature values are expected to be received in 20 bit format, positive, stored in a 32 bit signed integer. Humidity is expected to be received in 16 bit format, positive, stored in a 32 bit signed integer.

The variable `t_fine` (signed 32 bit) carries a fine resolution temperature value over to the pressure compensation formula and could be implemented as a global variable.

The data type "BME280_S32_t" should define a 32 bit signed integer variable type and could usually be defined as "long signed int". The revision of the code is rev. 1.1 (pressure and temperature) and rev. 1.0 (humidity).

Compensating the measurement value with double precision gives the best possible accuracy but is only recommended for PC applications.

```
// Returns temperature in DegC, double precision. Output value of "51.23" equals 51.23 DegC.
// t_fine carries fine temperature as global value
BME280_S32_t t_fine;
double BME280_compensate_T_double(BME280_S32_t adc_T)
{
    double var1, var2, T;
    var1 = (((double)adc_T)/16384.0 - ((double)dig_T1)/1024.0) * ((double)dig_T2);
    var2 = (((double)adc_T)/131072.0 - ((double)dig_T1)/8192.0) *
        (((double)adc_T)/131072.0 - ((double)dig_T1)/8192.0) * ((double)dig_T3);
    t_fine = (BME280_S32_t)(var1 + var2);
    T = (var1 + var2) / 5120.0;
    return T;
}

// Returns pressure in Pa as double. Output value of "96386.2" equals 96386.2 Pa = 963.862 hPa
double BME280_compensate_P_double(BME280_S32_t adc_P)
{
    double var1, var2, p;
    var1 = ((double)t_fine/2.0) - 64000.0;
    var2 = var1 * var1 * ((double)dig_P6) / 32768.0;
    var2 = var2 + var1 * ((double)dig_P5) * 2.0;
    var2 = (var2/4.0)+(((double)dig_P4) * 65536.0);
    var1 = (((double)dig_P3) * var1 * var1 / 524288.0 + ((double)dig_P2) * var1) / 524288.0;
    var1 = (1.0 + var1 / 32768.0)*((double)dig_P1);
    if (var1 == 0.0)
    {
        return 0; // avoid exception caused by division by zero
    }
    p = 1048576.0 - (double)adc_P;
    p = (p - (var2 / 4096.0)) * 6250.0 / var1;
    var1 = ((double)dig_P9) * p * p / 2147483648.0;
    var2 = p * ((double)dig_P8) / 32768.0;
    p = p + (var1 + var2 + ((double)dig_P7)) / 16.0;
    return p;
}

// Returns humidity in %rH as as double. Output value of "46.332" represents 46.332 %rH
double bme280_compensate_H_double(BME280_S32_t adc_H);
{
    double var_H;

    var_H = (((double)t_fine) - 76800.0);
    var_H = (adc_H - (((double)dig_H4) * 64.0 + ((double)dig_H5) / 16384.0 * var_H)) *
        (((double)dig_H2) / 65536.0 * (1.0 + ((double)dig_H6) / 67108864.0 * var_H *
        (1.0 + ((double)dig_H3) / 67108864.0 * var_H)));
    var_H = var_H * (1.0 - ((double)dig_H1) * var_H / 524288.0);

    if (var_H > 100.0)
        var_H = 100.0;
    else if (var_H < 0.0)
        var_H = 0.0;

    return var_H;
}
```

8.2 Pressure compensation in 32 bit fixed point

Please note that it is strongly advised to use the API available from Bosch Sensortec to perform readout and compensation. If this is not wanted, the code below can be applied at the user's risk. Both pressure and temperature values are expected to be received in 20 bit format, positive, stored in a 32 bit signed integer.

The variable `t_fine` (signed 32 bit) carries a fine resolution temperature value over to the pressure compensation formula and could be implemented as a global variable.

The data type "BME280_S32_t" should define a 32 bit signed integer variable type and can usually be defined as "long signed int".

The data type "BME280_U32_t" should define a 32 bit unsigned integer variable type and can usually be defined as "long unsigned int".

Compensating the pressure value with 32 bit integer has an accuracy of typically 1 Pa (1-sigma). At high filter levels this adds a significant amount of noise to the output values and reduces their resolution.

```
// Returns temperature in DegC, resolution is 0.01 DegC. Output value of "5123" equals 51.23 DegC.
// t_fine carries fine temperature as global value
BME280_S32_t t_fine;
BME280_S32_t BME280_compensate_T_int32(BME280_S32_t adc_T)
{
    BME280_S32_t var1, var2, T;
    var1 = (((adc_T >> 3) - ((BME280_S32_t)dig_T1 << 1)) * ((BME280_S32_t)dig_T2)) >> 11;
    var2 = (((((adc_T >> 4) - ((BME280_S32_t)dig_T1)) * ((adc_T >> 4) - ((BME280_S32_t)dig_T1))) >> 12) *
            ((BME280_S32_t)dig_T3)) >> 14;
    t_fine = var1 + var2;
    T = (t_fine * 5 + 128) >> 8;
    return T;
}

// Returns pressure in Pa as unsigned 32 bit integer. Output value of "96386" equals 96386 Pa = 963.86 hPa
BME280_U32_t BME280_compensate_P_int32(BME280_S32_t adc_P)
{
    BME280_S32_t var1, var2;
    BME280_U32_t p;
    var1 = (((BME280_S32_t)t_fine >> 1) - (BME280_S32_t)64000;
    var2 = (((var1 >> 2) * (var1 >> 2)) >> 11) * ((BME280_S32_t)dig_P6);
    var2 = var2 + ((var1 * ((BME280_S32_t)dig_P5) << 1);
    var2 = (var2 >> 2) + (((BME280_S32_t)dig_P4) << 16);
    var1 = (((dig_P3 * ((var1 >> 2) * (var1 >> 2)) >> 13) >> 3) + (((BME280_S32_t)dig_P2) * var1 >> 1)) >> 18;
    var1 = (((32768 + var1) * ((BME280_S32_t)dig_P1) >> 15);
    if (var1 == 0)
    {
        return 0; // avoid exception caused by division by zero
    }
    p = (((BME280_U32_t)(((BME280_S32_t)1048576) - adc_P) - (var2 >> 12)) * 3125;
    if (p < 0x80000000)
    {
        p = (p << 1) / ((BME280_U32_t)var1);
    }
    else
    {
        p = (p / (BME280_U32_t)var1) * 2;
    }
    var1 = (((BME280_S32_t)dig_P9) * ((BME280_S32_t)((p >> 3) * (p >> 3)) >> 13)) >> 12;
    var2 = (((BME280_S32_t)(p >> 2)) * ((BME280_S32_t)dig_P8) >> 13;
    p = (BME280_U32_t)((BME280_S32_t)p + ((var1 + var2 + dig_P7) >> 4));
    return p;
}
```

9. Appendix B: Measurement time and current calculation

In this chapter, formulas are given to calculate measurement rate, filter bandwidth and current consumption in different settings.

9.1 Measurement time

The active measurement time depends on the selected values for humidity, temperature and pressure oversampling and can be calculated in milliseconds using the formulas below.

$$t_{\text{measure,typ}} = 1 + [2 \cdot T_{\text{oversampling}}]_{\text{osrs}_t \neq 0} + [2 \cdot P_{\text{oversampling}} + 0.5]_{\text{osrs}_p \neq 0} + [2 \cdot H_{\text{oversampling}} + 0.5]_{\text{osrs}_h \neq 0}$$

$$t_{\text{measure,max}} = 1.25 + [2.3 \cdot T_{\text{oversampling}}]_{\text{osrs}_t \neq 0} + [2.3 \cdot P_{\text{oversampling}} + 0.575]_{\text{osrs}_p \neq 0} + [2.3 \cdot H_{\text{oversampling}} + 0.575]_{\text{osrs}_h \neq 0}$$

For example, using temperature oversampling $\times 1$, pressure oversampling $\times 4$ and no humidity measurement, the measurement time is:

$$t_{\text{measure,typ}} = 1 + [2 \cdot 1] + [2 \cdot 4 + 0.5] + [0] = 11.5 \text{ ms}$$

$$t_{\text{measure,max}} = 1.25 + [2.3 \cdot 1] + [2.3 \cdot 4 + 0.575] + [0] = 13.325 \text{ ms}$$

9.2 Measurement rate in forced mode

In forced mode, the measurement rate depends on the rate at which it is forced by the master. The highest possible frequency in Hz can be calculated as:

$$ODR_{\text{max,forced}} = \frac{1000}{t_{\text{measure}}}$$

If measurements are forced faster than they can be executed, the data rate saturates at the attainable data rate. For the example above with 11.5 ms measurement time, the typically achievable output data rate would be:

$$ODR_{\text{max,forced}} = \frac{1000}{11.5} = 87 \text{ Hz}$$

9.3 Measurement rate in normal mode

The measurement rate in normal mode depends on the measurement time and the standby time and can be calculated in Hz using the following formula:

$$ODR_{\text{normal_mode}} = \frac{1000}{t_{\text{measure}} + t_{\text{standby}}}$$

The accuracy of t_{standby} is described in the specification parameter $\Delta t_{\text{standby}}$. For the example above with 11.5 ms measurement time, setting normal mode with a standby time of 62.5 ms would result in a data rate of:

$$ODR_{\text{normal_mode}} = \frac{1000}{11.5 + 62.5} = 13.51 \text{ Hz}$$

9.4 Response time using IIR filter

When using the IIR filter, the response time of the sensor depends on the selected filter coefficient and the data rate used. It can be calculated using the following formula:

$$t_{response, 75\%} = \frac{1000 \cdot n_{samples, 75\%}}{ODR}$$

For the example above with a data rate of 13.51 Hz, the user could select a filter coefficient of 8. According to Table 6, the number of samples needed to reach 75% of a step response using this filter setting is 11. The response time with filter is therefore:

$$t_{response, 75\%} = \frac{1000 \cdot 11}{13.51} = 814 \text{ ms}$$

9.5 Current consumption

The current consumption depends on the selected oversampling settings, the measurement rate and the sensor mode, but not on the IIR filter setting. It can be calculated as:

$$I_{DD,forced} = I_{DDSL} \cdot (1 - t_{measure} \cdot ODR) + \frac{ODR}{1000} \cdot (205 + I_{DDT} \cdot [2 \cdot T_{oversampling}]_{osrs_t \neq 0} + I_{DDP} \cdot [2 \cdot P_{oversampling} + 0.5]_{osrs_p \neq 0} + I_{DDH} \cdot [2 \cdot H_{oversampling} + 0.5]_{osrs_h \neq 0})$$

$$I_{DD,normal} = I_{DDSB} \cdot (1 - t_{measure} \cdot ODR) + \frac{ODR}{1000} \cdot (205 + I_{DDT} \cdot [2 \cdot T_{oversampling}]_{osrs_t \neq 0} + I_{DDP} \cdot [2 \cdot P_{oversampling} + 0.5]_{osrs_p \neq 0} + I_{DDH} \cdot [2 \cdot H_{oversampling} + 0.5]_{osrs_h \neq 0})$$

Note that the only difference between forced and normal mode current consumption is that the current for the inactive time is either I_{DDSL} or I_{DDSB} . For the example above, the current would be

$$\begin{aligned} I_{DD,normal} &= 0.2 \cdot (1 - 0.0115 \cdot 13.51) + \frac{13.51}{1000} (205 + 350 \cdot [2 \cdot 1] + 714 \cdot [2 \cdot 4 + 0.5] + [0]) \\ &= 0.2 \cdot (0.845) + \frac{13.51}{1000} (205 + 700 + 6069 + 0) \\ &= 0.2 + 94.2 = 94.4 \mu\text{A} \end{aligned}$$

10. Legal disclaimer

10.1 Engineering samples

Engineering Samples are marked with an asterisk (*) or (e) or (E). Samples may vary from the valid technical specifications of the product series contained in this data sheet. They are therefore not intended or fit for resale to third parties or for use in end products. Their sole purpose is internal client testing. The testing of an engineering sample may in no way replace the testing of a product series. Bosch Sensortec assumes no liability for the use of engineering samples. The Purchaser shall indemnify Bosch Sensortec from all claims arising from the use of engineering samples.

10.2 Product use

Bosch Sensortec products are developed for the consumer goods industry. They may only be used within the parameters of this product data sheet. They are not fit for use in life-sustaining or security sensitive systems. Security sensitive systems are those for which a malfunction is expected to lead to bodily harm or significant property damage. In addition, they are not fit for use in products which interact with motor vehicle systems.

The resale and/or use of products are at the purchaser's own risk and his own responsibility. The examination of fitness for the intended use is the sole responsibility of the purchaser.

The purchaser shall indemnify Bosch Sensortec from all third party claims arising from any product use not covered by the parameters of this product data sheet or not approved by Bosch Sensortec and reimburse Bosch Sensortec for all costs in connection with such claims.

The purchaser must monitor the market for the purchased products, particularly with regard to product safety, and inform Bosch Sensortec without delay of all security relevant incidents.

10.3 Application examples and hints

With respect to any examples or hints given herein, any typical values stated herein and/or any information regarding the application of the device, Bosch Sensortec hereby disclaims any and all warranties and liabilities of any kind, including without limitation warranties of non-infringement of intellectual property rights or copyrights of any third party. The information given in this document shall in no event be regarded as a guarantee of conditions or characteristics. They are provided for illustrative purposes only and no evaluation regarding infringement of intellectual property rights or copyrights or regarding functionality, performance or error has been made.

10.4 Handling Instructions

Detailed handling instructions are described in the document "handling, soldering & mounting instructions (HSMI)".

Important to highlight is the directive to avoid during manufacturing, transport and usage of the sensor in devices the contact of high concentration of chemical solvents and long exposure times. Chemical interactions of chemical compounds with the sensor shall be prevented. These are especially outgassing of corrugated plastic, organic glues, sticky tape made with adhesives, labels, marker or outgassing package materials such as bubble wrap, foams and others shall be avoided. It is recommended to ventilate the production and manufacturing area.

11. Document history and modification

Rev. No	Chapter	Description of modification/changes	Date
0.1		Document creation	2012-11-06
1.0		Final datasheet	2014-11-12
1.1	8.12.1	Updated RoHS directive to 2011/65/EU effective 8 June 2011	2015-05-07

Bosch Sensortec GmbH
Gerhard-Kindler-Strasse 8
72770 Reutlingen / Germany

contact@bosch-sensortec.com
www.bosch-sensortec.com

Modifications reserved
Specifications subject to change without notice
Document number: BST-BME280-DS001-09
Revision_1.0_November 2014