

Microwave Motion Sensor Preliminary Data

KMY 24

Description

The KMY 24 is a microwave radar motion sensor based on the Doppler effect. It transmits a low energy microwave radiation at 2.45 GHz which is reflected by objects. If the object is moving relative to the sensor, a Doppler shift occurs. The shifted wave is mixed with the original wave in two mixers, resulting in two output voltage signals. The phase shift between these two signals is negative or positive depending on whether the target is approaching or receding from the detector.

Features

- High sensitivity
- Dual Mixers enabling direction detecting
- High reliability
- Low power consumption
- Low harmonic emission
- Small size
- Light weight
- Low cost

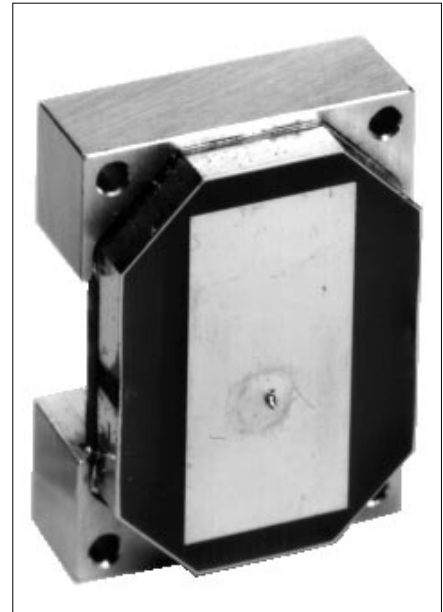

Engineering Sample

Typ	Marking	Ordering Code	Operating frequency	License No.
KMY 24	KMY 24	Q62702-R323	2.45 GHz	BZT G127520H

Pin Configuration

1	$-V_S$ (GND)
2	V_{D1} (output voltage D1)
3	V_{D2} (output voltage D2)
4	$+V_S$

Note: Solder pads must not be perforated, as this will damage, and may destroy the multilayer PC Board.

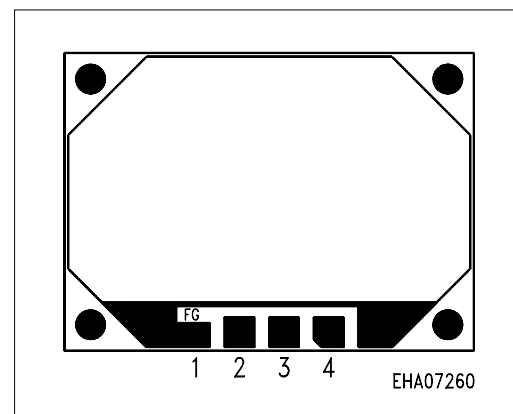

Absolute Maximum Ratings

Parameter	Symbol	Limit Values	Unit
Operating temperature range	T_{op}	- 20 ... + 60	°C
Storage temperature range	T_{stg}	- 30 ... + 80	°C
Supply voltage	V_S	15.6	V

Electrical Characteristics

at $T_A = 25\text{ °C}$

Parameter	Symbol	Limit Values			Unit
		min.	typ.	max	
Supply voltage	V_S	10.8	12	15.6	V
Operating frequency	f_o	2.40	2.45	2.48	GHz
Operating current	I_{op}	-	23	-	mA
Detecting range ¹⁾	r_{op}	-	5 ... 8	-	m
Amplitude of signal 1	V_{D1}	-	¹⁾	-	mV
Quotient of amplitude of 1 and 2	V_{D1}/V_{D2}	-	2	-	
Phase difference	$\varphi_2 - \varphi_1$	-	40 ... 120	-	Degrees
Equivalent isotropic radiated power at f_o	<i>EIRP</i>	-	8	-	dBm

1) The amplitude of the signal depends on the object size and its distance from the detector. Measurements taken with 5 cm high, cylindrical metallic objects, moving in circles at a distance of 1 m for example, give signal amplitudes of typically $V_{D1} = 40\text{ mV}$.

Output Signal

The phase difference between V_{D2} and V_{D1} is positive, if the target is receding from the detector.

$$(\varphi_1 - \varphi_2) \geq 0$$

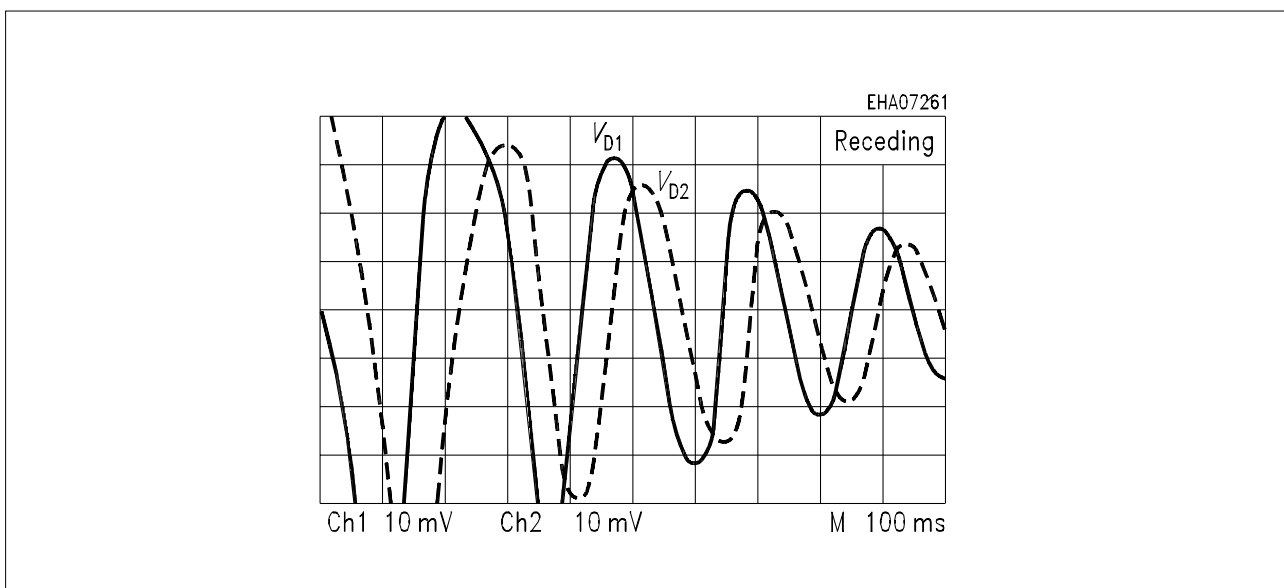

The phase difference between V_{D2} and V_{D1} is negative, if the target is approaching the detector.

$$(\varphi_1 - \varphi_2) \geq 0$$

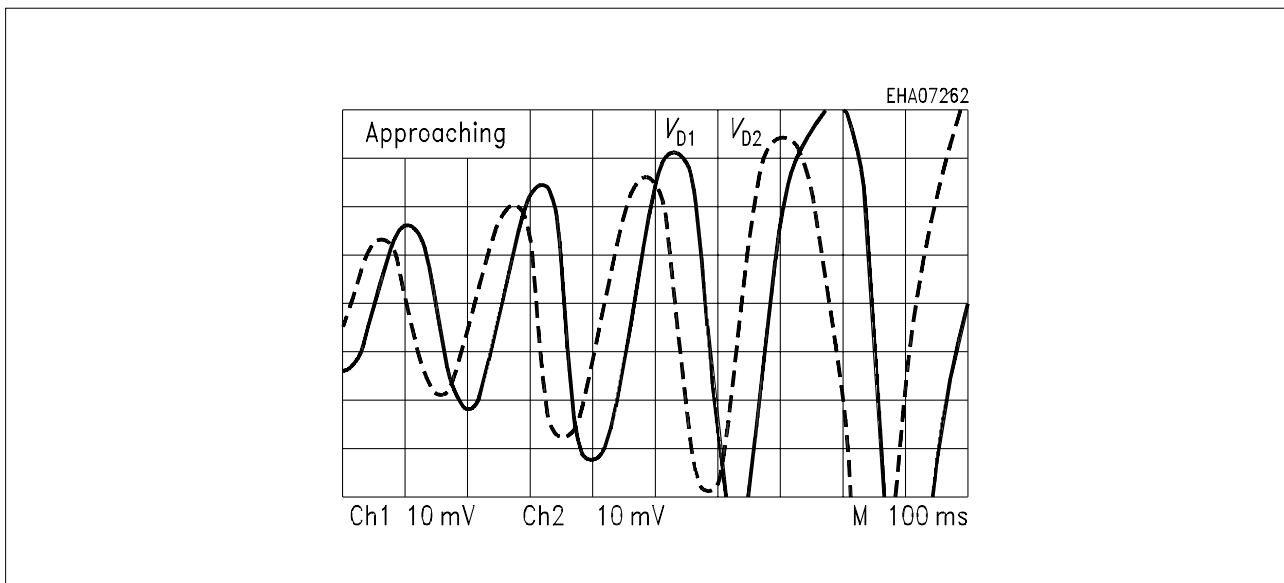

Typical Radiation Pattern

The diagram shows the typical radiation pattern in the x-z- and y-z-planes. The z-direction is perpendicular to the patch antenna, x shows the longer and y the shorter side of the rectangular antenna.

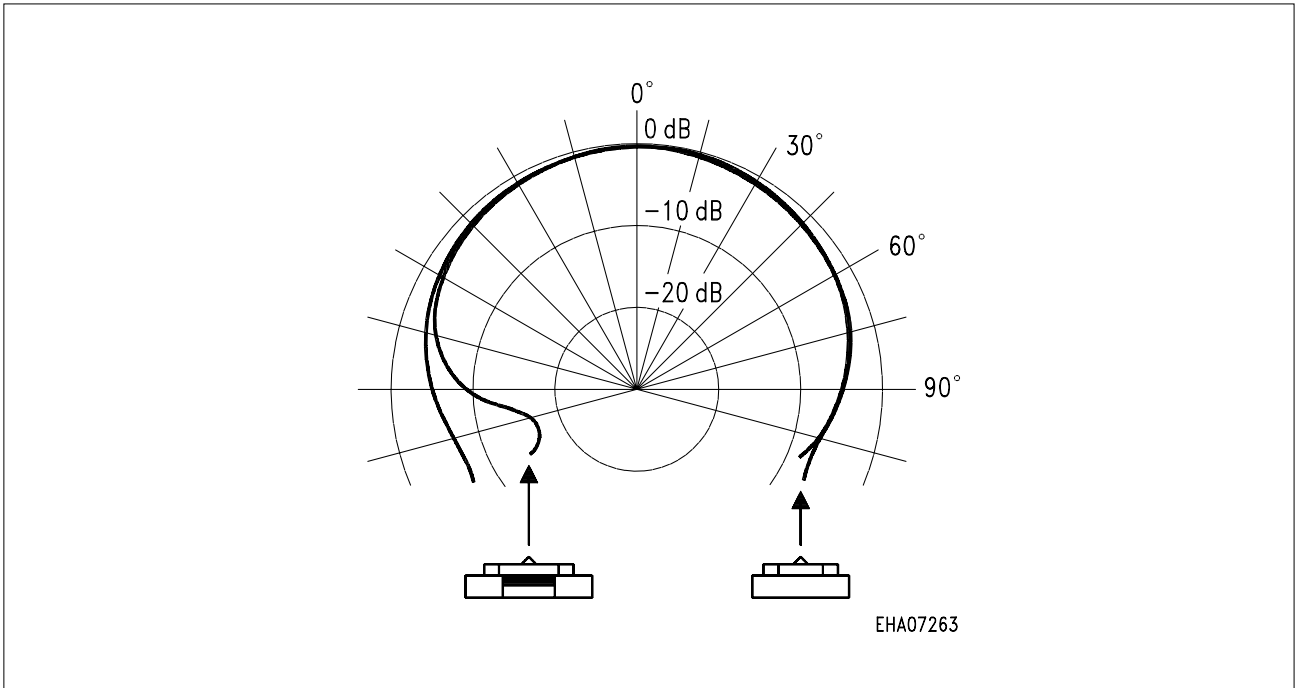

Package Outline

The outline of the package has, to date, not been determined.

Doppler Modules KMY10 / KMY24

Basics

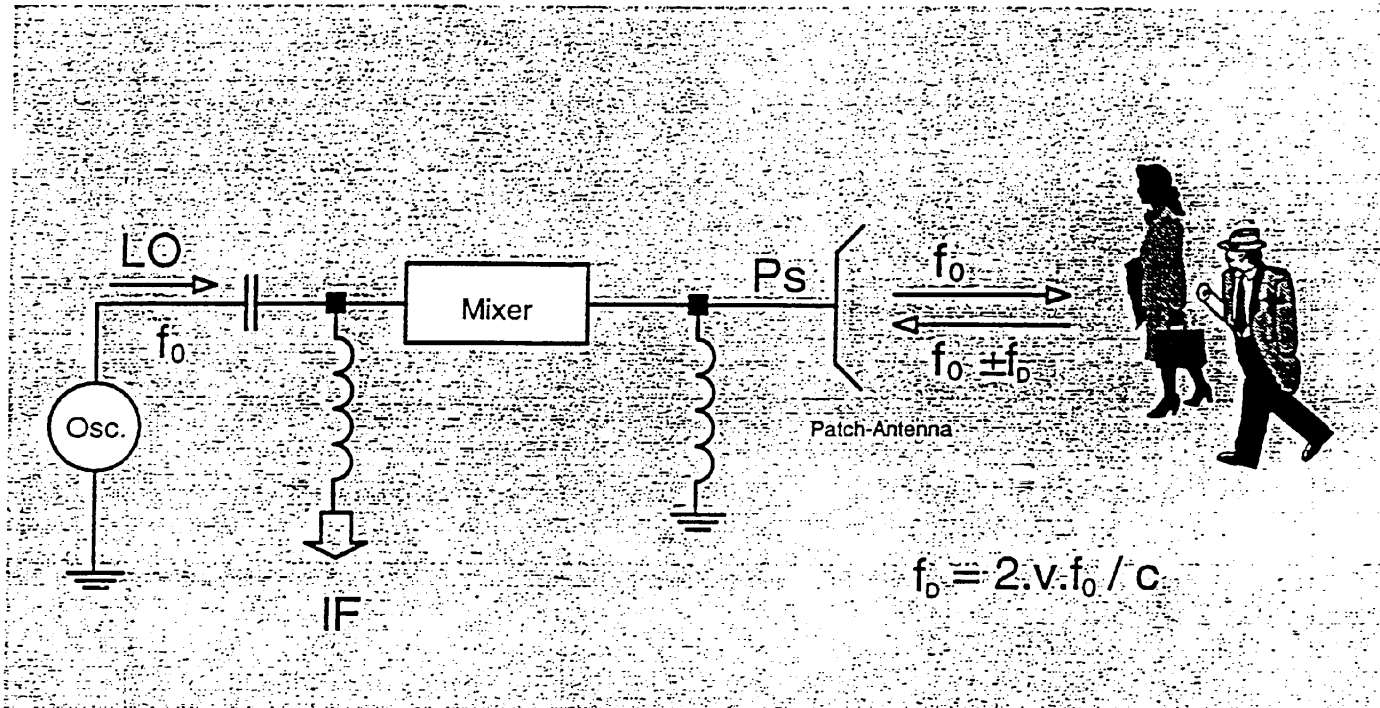

	KMY10	KMY24
Osc.	CFY30	BFR92P
Ps	dielectric Res. - 6dBm	coaxial Res. + 6 dBm
Antenna	6 dB	2 dB
IF (target vel.: 5 km/h)	86.6 Hz	22.7 Hz