

## DISTINCTIVE CHARACTERISTICS

Programmable to display graphics, alphanumeric characters and animated sequences.

Integrated liquid crystal display provides wide viewing angle with high contrast and clarity.

Built-in single color LED enhances display and enables multifunctional uses.

Viewing area 15.0mm x 10.8mm (horizontal x vertical) at 36 x 24 pixels.

Dome contact gives crisp tactile feedback to positively indicate circuit transfer and assures high reliability and long life of one million actuations minimum.

Epoxy sealed terminals prevent entry of solder flux and other contaminants.

Optional accessories available to enhance panel design.

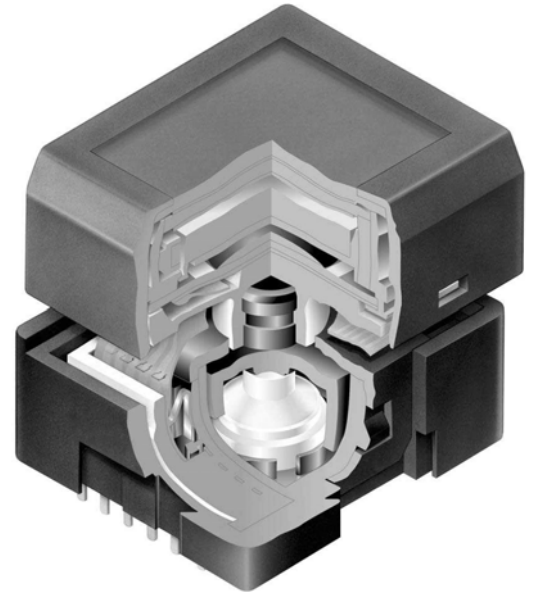

## SWITCH ORDERING PART NUMBER

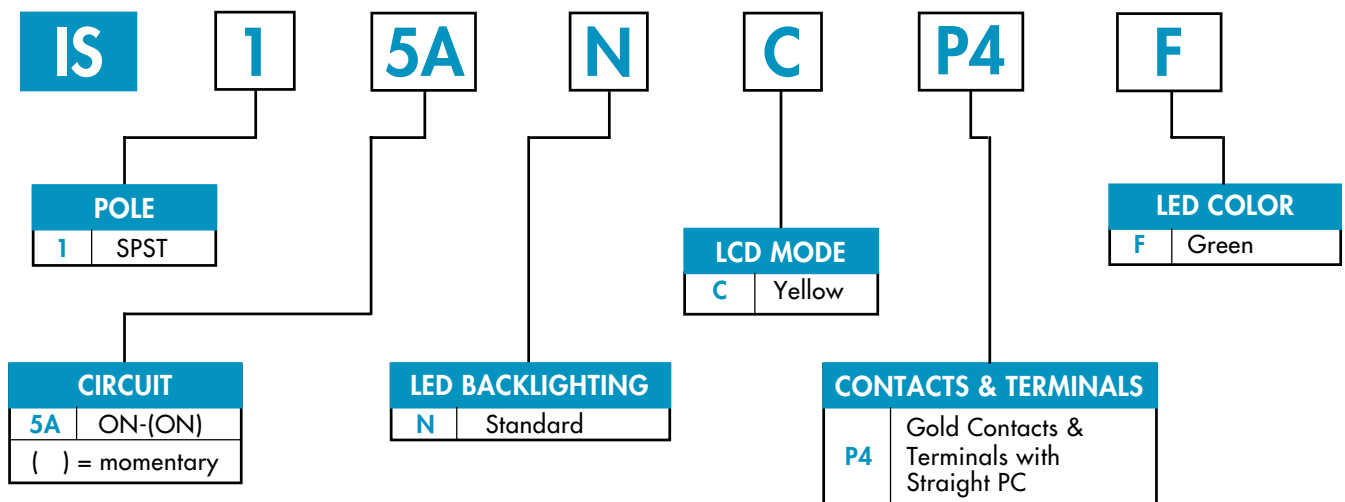

## SWITCH SPECIFICATIONS

Circuit	SPST normally open
Electrical Capacity (Resistive Load)	100mA @ 12V DC
Contact Resistance	200 milliohms maximum @ 20mV 10mA
Insulation Resistance	100 megohms minimum @100V DC
Dielectric Strength	125V AC for 1 minute
Mechanical Endurance	1,000,000 operations minimum
Electrical Endurance	1,000,000 operations minimum
Operating Force	2.2 ± 0.5 Newtons
Total Travel	1.8mm
Operating Temperature Range	0°C through +40°C (32°F through 104°F)
Storage Temperature Range	-10°C through +60°C (14°F through 140°F)



## LCD SPECIFICATIONS

### Characteristics of Display

Display Operation Mode	STN positive. Background color: Yellow
Display Condition	Transflective with built-in LED backlight
Viewing Angle Direction	Adjustable
Driving Method	1/24 duty. 1/5 bias (built-in driving circuit)
Viewing Area	15.0mm x 10.8mm (horizontal x vertical)
Pixel Format	36 x 24 dots (horizontal x vertical)
Pixel Size	0.36mm x 0.36mm (horizontal x vertical)
Backlight LED	Green



### Absolute Maximum Ratings (Temperature at 25°C)

Items	Symbols	Ratings
Supply Voltage for Logics	$V_{DD}$	-0.3V to +7.0V
Supply Voltage for LCD	$V_{LC}$	-0.3V to +12.0V
Input Voltage	$V_I$	-0.3V to $V_{DD}$ +0.3V
Output Voltage	$V_O$	-0.3V to $V_{DD}$ +0.3V

### Recommended Operating Conditions (Temperature at 25°C)

Items	Symbols	Minimum	Typical	Maximum
Supply Voltage for Logics	$V_{DD}$	4.5V	5.0V	5.5V
Supply Voltage for LCD	$V_{LC}$	—	7.4V	—
Input Voltage	$V_I$	0V	—	$V_{DD}$
Driving Frequency	$f_{FLM}$	—	64Hz	—
Clock Operation Frequency	$f_{SCP}$	—	—	6.0MHz

### DC Characteristics of LCD Drive IC

(Temperature at 0°C to 40°C & VDD = 5.0V±10%)

Items	Symbols	Test Conditions	Min.	Typical	Max.
High Level Input Voltage	$V_{IH}$		0.7 $V_{DD}$		$V_{DD}$
Low Level Input Voltage	$V_{IL}$		0		0.3 $V_{DD}$
High Level Input Leakage Current	$I_{LH}$	$V_I = V_{DD}$			10 $\mu$ A
Low Level Input Leakage Current	$I_{LI}$	$V_I = 0V$			-10 $\mu$ A
High Level Output Voltage	$V_{OH}$	$I_{OH} = -500\mu A$	$V_{DD} - 0.5V$		
Low Level Output Voltage	$V_{OL}$	$I_{OL} = 500\mu A$			0.5V
High Level Output Leakage Current	$I_{LOH}$	$V_O = V_{DD}$			10 $\mu$ A
Low Level Output Leakage Current	$I_{LOL}$	$V_O = 0V$			-10 $\mu$ A
Supply Current	$I_{DD}$	$f_{SCP} = 1.0MHz$			500 $\mu$ A
LCD Drive Current	$I_{LC}$	$f_{LP} = 2.4kHz$ $V_{LC} = 7.4V$		500 $\mu$ A	2,000 $\mu$ A

### Timing Characteristics of LCD Drive IC

(Temperature at 0°C to 40°C & VDD = 5.0V±10%)

Items	Symbols	Minimum	Maximum
Clock Operation Frequency	$f_{SCP}$		6.0MHz
Latch Pulse Frequency	$f_{LP}$		50kHz
Clock High Level Pulse Width	$t_{CWH}$	70ns	
Clock Low Level Pulse Width	$t_{CWL}$	70ns	
Data Setup Time	$t_{DSD}$	45ns	
Data Hold Time	$t_{DHD}$	50ns	
Data Output Delay Time	$t_{PDO}$		25ns
Latch Setup Time	$t_{DSL}$	50ns	
Latch Hold Time	$t_{DHL}$	50ns	
Latch High Level Width	$t_{LWH}$	200ns	
FLM Setup Time	$t_{DSF}$	50ns	
FLM Hold Time	$t_{DHF}$	50ns	
SCP, LP Rise/Fall Time	$t_r/t_f$		15ns

### Timing Diagram

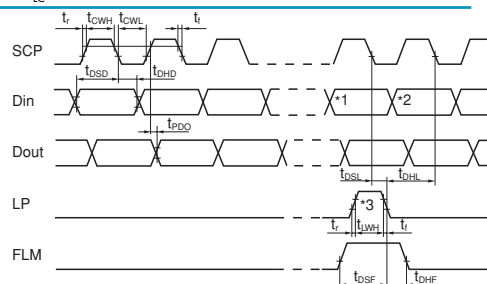

\*1 Last data on first line

\*2 Beginning data on second line

\*3 Location of LP signal on first line

**BLOCK DIAGRAM**

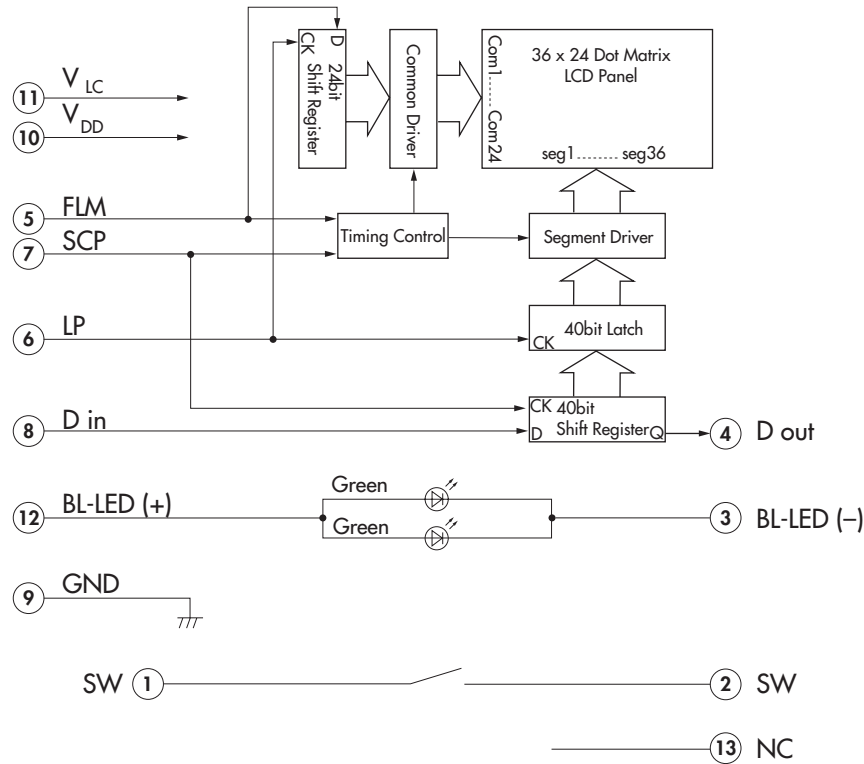

**PIN CONFIGURATIONS**

Pin No.	Symbol	Name	Function
①	SW	Terminal of Switch	Normally open
②	SW	Terminal of Switch	Normally open
③	BL-LED (-)	Terminal of Backlight LED	Cathode for green
④	D out	Data output	Display serial output. Can be used to connect to Din of the next switch. As a result, many switches can be controlled with one clock and data signal.
⑤	FLM	First Line Marker	The marking signal for the first line data of LCD display. The first line of LCD will be selected by the falling edge of LP signal during the high level (FLM).
⑥	LP	Latch Pulse	Line data latch pulse will latch content of internal 40-bit shift register at falling edge for one line of display. LP will also increment the display line by one.
⑦	SCP	Serial Clock Pulse	Clock used by 40-bit internal shift register of the switch, shifting the display data bit presented at Din at falling edge.
⑧	D in	Data input	Display serial data bit. Note: to map the display data, because of the difference between the number of internal shift register data (40) and the single line of LCD pixels (36), the first four bits of data shifted will be dummy bits.
⑨	GND	Ground	
⑩	V <sub>DD</sub>	Power	Power source for logic circuit
⑪	V <sub>LC</sub>	Power	Power source for LCD drive
⑫	BL-LED (+)	Terminal of Backlight LED	Anode for common
⑬	NC		No connection

## STANDARD LED SPECIFICATIONS

Typical Electrical Characteristics (Temperature at 25°C)

Backlight Color		Green	Unit
Forward Current	$I_F$	30	mA
Forward Voltage	$V_F$	2.2	V

## ABSOLUTE MAXIMUM FOR ALL LEDs

Electrical Characteristics (Temperature at 25°C)

Backlight Color		Green	Unit
Forward Current	$I_F$	40	mA
Reverse Voltage	$V_R$	4.0	V
Current Reduction Rate Above 25°C	$\Delta I_F$ (DC)	-0.26	mA/°C
Power Dissipation	$P_d$	260 max.	mW

## TYPICAL SWITCH DIMENSIONS

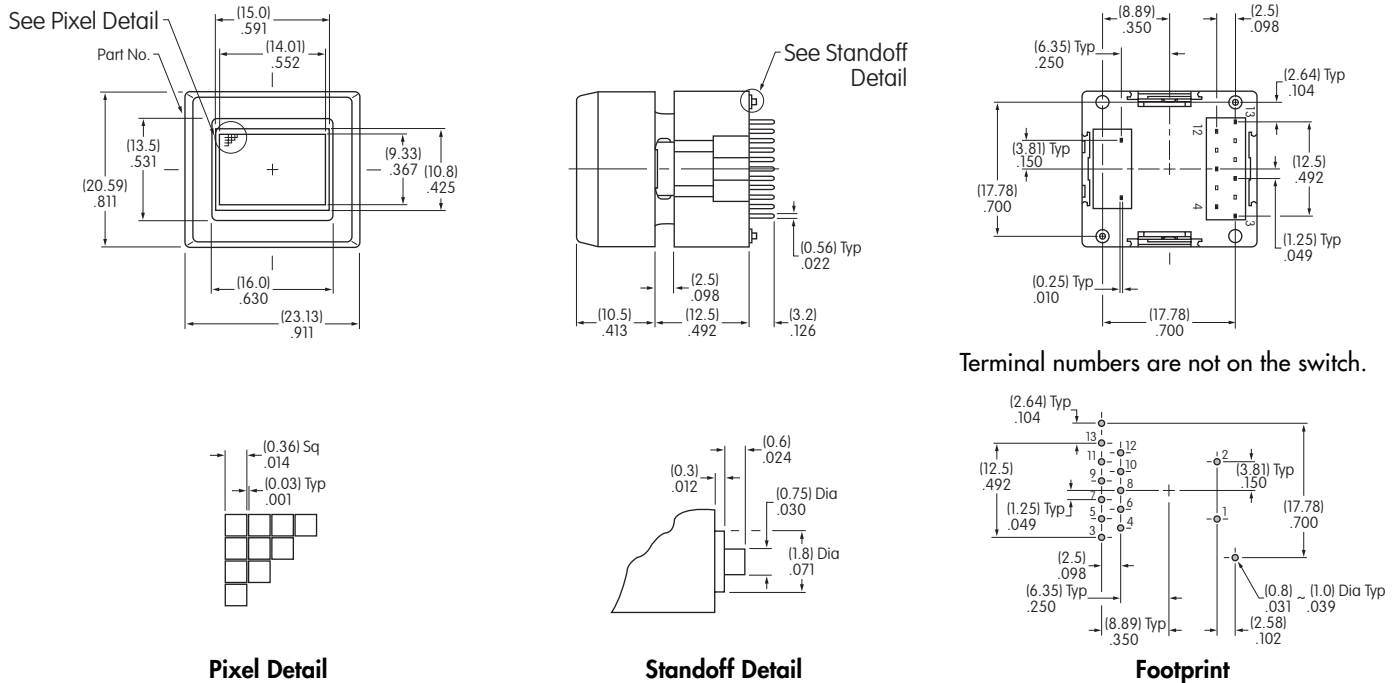

## IMPORTANT HANDLING & STORAGE INSTRUCTIONS

### Handling

1. To avoid damaging the IC, touch the key tops only when isolated from static electricity.
2. Avoid excessive operating force (maximum 100 Newtons) to protect the LCD.
3. Recommended soldering time and temperature limits are 5 seconds @ 270°C.
4. Temperature exceeding 60°C at the LCD must be avoided.
5. The IS series devices are not process sealed.
6. If the LCD is accidentally broken, avoid contact with the liquid and wash off any liquid spills to the skin or clothing.

### Storage

1. Store away from direct sunlight.
2. Keep away from static electricity.
3. Avoid extreme temperatures, high humidity, gaseous substances, and all forms of chemical contamination.