

H@K & GSM Charging / Ignition

Piaggio Ltd.

23/04/02

Gilera engine

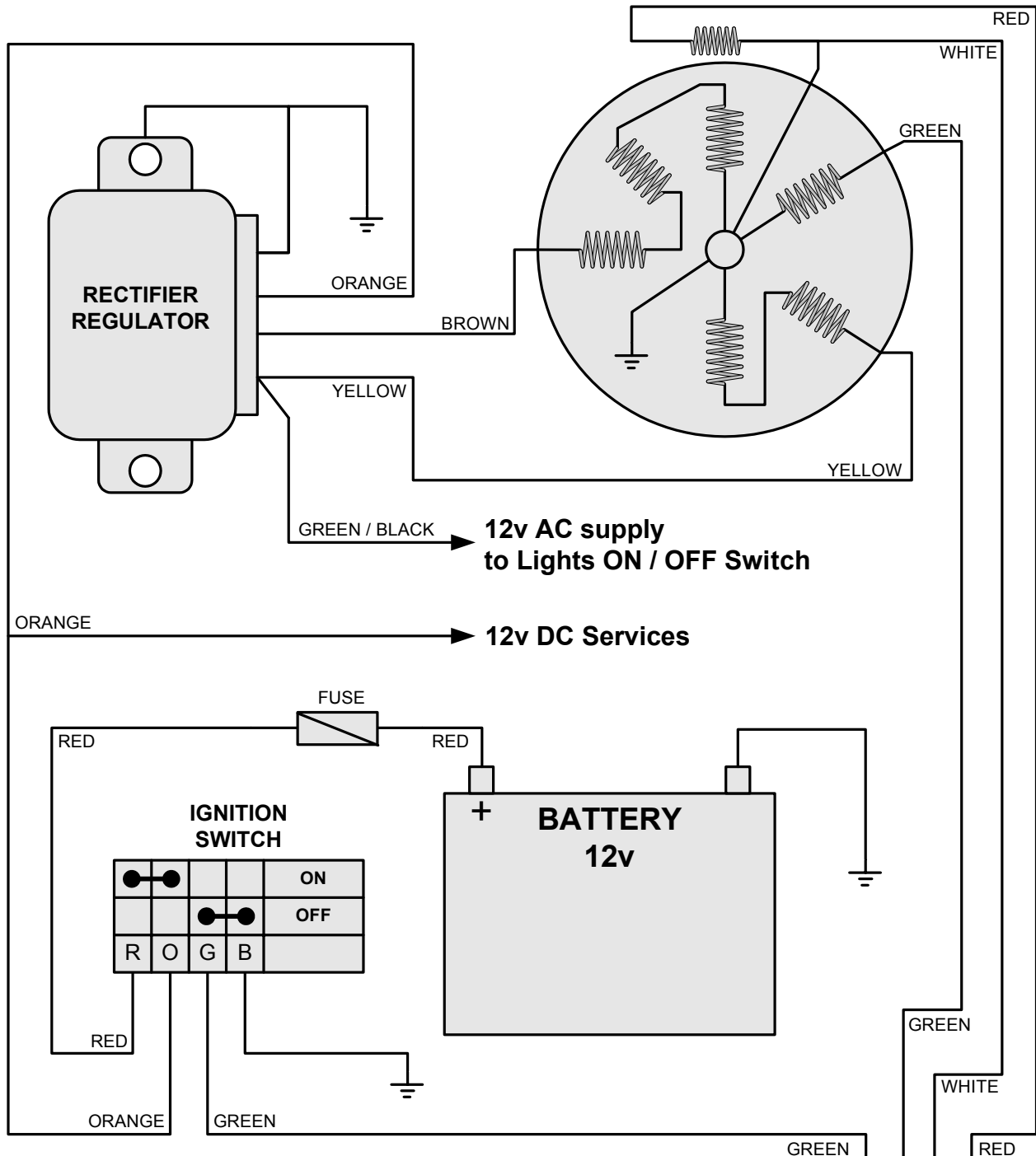

- * Stator has separate coils for AC, DC and Ignition circuits.
Brown wire = supply for DC (battery circuit)
Yellow wire = supply for AC circuit
Green wire = supply for ignition
- * Important that Stator has a good earth to engine and engine must have good earth to chassis and battery.
- * All Lights are powered by 12v AC
- * Ignition is self generating and does not need the other electrical circuits or the battery.
- * Ignition is stopped by shorting the charge coil (green wire) to earth.
Check: Unplug Green wire from stator and CDI unit. You should have continuity from green to earth with ignition OFF and no continuity with ignition ON.

This information should not be used for Derbi Engine bikes