

AVX
Tantalum Leaded
Capacitors

AVX Tantalum Ask The World Of Us

As one of the world's broadest line leded tantalum suppliers, and the major radial tantalum manufacturer, it is our mission to provide **First In Class** Technology, Quality and Service, by establishing progressive design, manufacturing and continuous improvement programs driving toward a single goal:
TOTAL CUSTOMER SATISFACTION

AVX Tantalum Leaded Products

- TAP** – Resin Dipped Radial Capacitor
- TAR** – Molded Axial Capacitor
- TAA** – Hermetic Sealed Axial Capacitor
- TMH** – Precision Microminiature Capacitor
(Axial or Radial)

Foreword

AVX offers a broad line of solid tantalum capacitors in a wide range of sizes, styles, and ratings to meet any design needs. This catalog combines into one source AVX's leaded tantalum capacitor information from its worldwide tantalum operations.

The TAP is rated for use from -55°C to +85°C at rated voltage and up to +125°C with voltage derating. There are three preferred wire forms to choose from which are available on tape and reel, and in bulk for hand insertion.

Four sizes of molded axials, the TAR series, are also available. The TAR is fully marked and available on tape and reel for high speed insertion. The TAA is a hermetically sealed series also with four case sizes available.

The TMH series (MINITAN®) leaded capacitors are available in both axial and radial configurations. The TMH series is designed with small battery-

powered applications, such as hearing aids, in mind. The "X" case size in the TMH line is the smallest leaded tantalum capacitor available in the world.

AVX has a complete tantalum applications service available for use by all our customers. With the capability to prototype and mass produce solid tantalum capacitors in special configurations, almost any design need can be fulfilled. And if the customer requirements are outside our standard testing, AVX will work with you to define and implement a test or screening plan.

AVX is determined to become the world leader in tantalum capacitor technology and has made, and is continuing to make, significant investments in equipment and research to reach that end. We believe that the investment has paid off with the devices shown on the following pages.

Contents

		Page
Introduction	Foreword	1
Dipped Radial Capacitors	Introduction	2
	TAP Series	3-6
	Tape and Reel Packaging	7-8
Axial Capacitors	TAR Series	9-11
	TAA Series	12-14
	Tape and Reel Packaging	15
MINITAN® Capacitors	TMH Series	16-18
Technical Summary and Application Guidelines	19-31

Dipped Radial Capacitors



Introduction

SOLID TANTALUM RESIN DIPPED SERIES TAP

The TAP resin dipped series of miniature tantalum capacitors is available for individual needs in both commercial and professional applications. From computers to automotive to industrial, AVX has a dipped radial for almost any application.

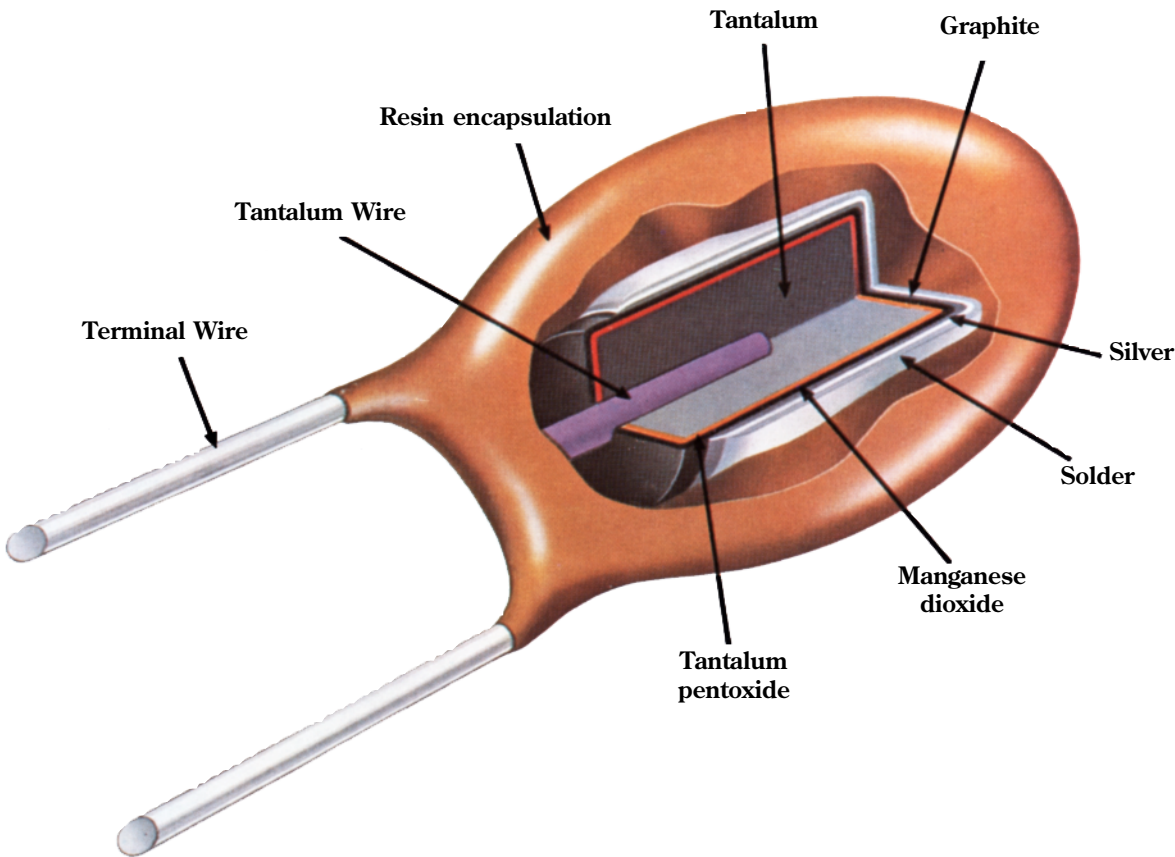

Dipped Radial Capacitors



Wire Form Outline

SOLID TANTALUM RESIN DIPPED TAP

Preferred Wire Forms

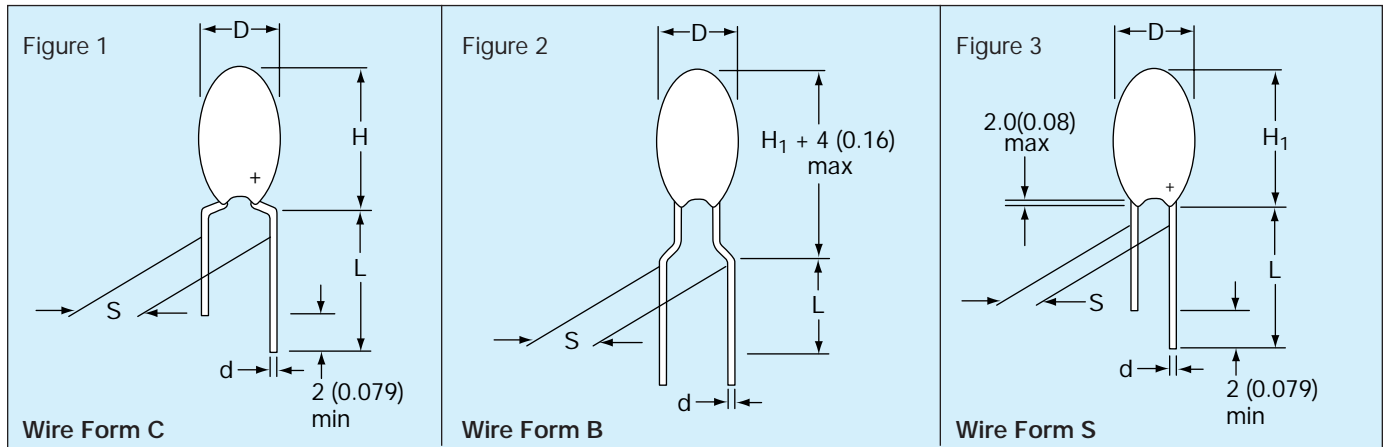

Non-Preferred Wire Forms (Not recommended for new designs)

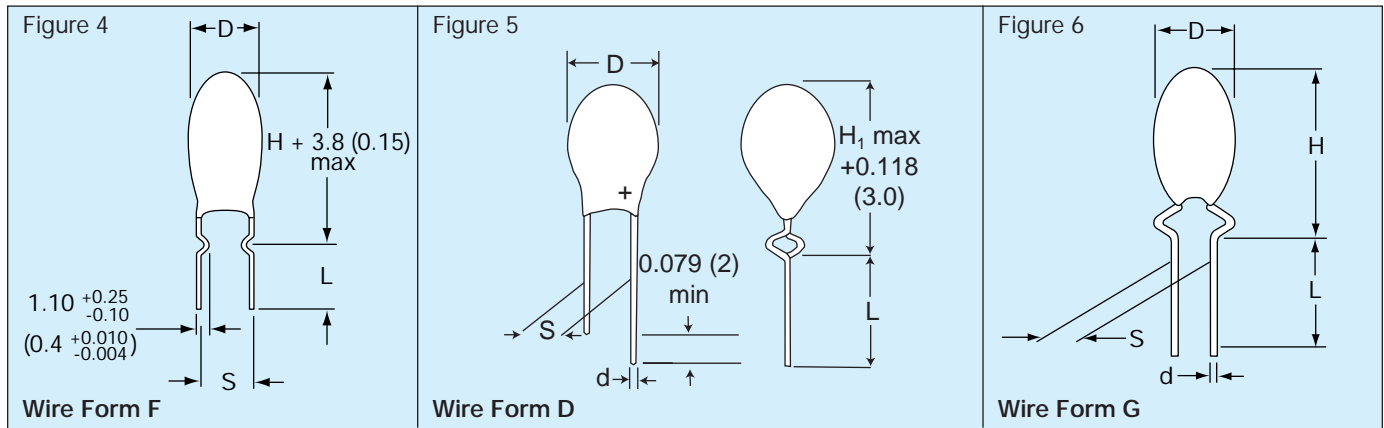

DIMENSIONS

Wire Form	Figure	Case Size	L (see note 1)	S	d	Packaging Suffixes Available*
-----------	--------	-----------	----------------	---	---	-------------------------------

Preferred Wire Forms

C	Figure 1	A - R*	16±4 (0.630±0.160)	5.0±1.0 (0.200±0.040)	0.5±0.05 (0.020±0.002)	CCS Bulk CRW Tape/Reel CRS Tape/Ammo
B	Figure 2	A - J*	16±4 (0.630±0.160)	5.0±1.0 (0.200±0.040)	0.5±0.05 (0.020±0.002)	BCS Bulk BRW Tape/Reel BRS Tape/Ammo
S	Figure 3	A - J*	16±4 (0.630±0.160)	2.5±0.5 (0.100±0.020)	0.5±0.05 (0.020±0.002)	SCS Bulk SRW Tape/Reel SRS Tape/Ammo

Non-Preferred Wire Forms (Not recommended for new designs)

F	Figure 4	A - R	3.9±0.75 (0.155±0.030)	5.0±0.5 (0.200±0.020)	0.5±0.05 (0.020±0.002)	FCS Bulk
D	Figure 5	A - H*	16±4 (0.630±0.160)	2.5±0.75 (0.100±0.020)	0.5±0.05 (0.020±0.002)	DCS Bulk DTW Tape/Reel DTS Tape/Ammo
G	Figure 6	A - J	16±4 (0.630±0.160)	3.18±0.5 (0.125±0.020)	0.5±0.05 (0.020±0.002)	GSB Bulk
H	Similar to Figure 1	A - R	16±4 (0.630±0.160)	6.35±1.0 (0.250±0.040)	0.5±0.05 (0.020±0.002)	HSB Bulk

Notes: (1) Lead lengths can be supplied to tolerances other than those above and should be specified in the ordering information.

(2) For D, H, and H₁ dimensions, refer to individual product on following pages.

* For case size availability in tape and reel, please refer to page 7-8.



Dipped Radial Capacitors



TAP Series

SOLID TANTALUM RESIN DIPPED CAPACITORS



TAP is a professional grade device manufactured with a flame retardant coating and featuring low leakage current and impedance, very small physical sizes and exceptional temperature stability. It is designed and conditioned to operate to +125°C (see page 27 for voltage derating above 85°C) and is available loose or taped and reeled for auto insertion. The 15 case sizes with wide capacitance and working voltage ranges means the TAP can accommodate almost any application.

Maximum Case Dimensions: millimeters (inches)			
Wire Case	C, F, G, H H	B, S, D *H ₁	D
A	8.5 (0.33)	7.0 (0.28)	4.5 (0.18)
B	9.0 (0.35)	7.5 (0.30)	4.5 (0.18)
C	10.0 (0.39)	8.5 (0.33)	5.0 (0.20)
D	10.5 (0.41)	9.0 (0.35)	5.0 (0.20)
E	10.5 (0.41)	9.0 (0.35)	5.5 (0.22)
F	11.5 (0.45)	10.0 (0.39)	6.0 (0.24)
G	11.5 (0.45)	10.0 (0.39)	6.5 (0.26)
H	12.0 (0.47)	10.5 (0.41)	7.0 (0.28)
J	13.0 (0.51)	11.5 (0.45)	8.0 (0.31)
K	14.0 (0.55)	12.5 (0.49)	8.5 (0.33)
L	14.0 (0.55)	12.5 (0.49)	9.0 (0.35)
M	14.5 (0.57)	13.0 (0.51)	9.0 (0.35)
N	16.0 (0.63)		9.0 (0.35)
P	17.0 (0.67)		10.0 (0.39)
R	18.5 (0.73)		10.0 (0.39)

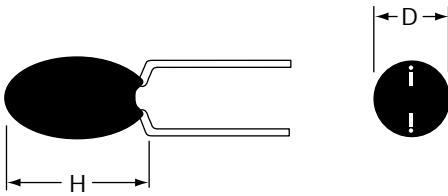

HOW TO ORDER

TAP

Type

475

Capacitance Code
pF code: 1st two digits
represent significant figures,
3rd digit represents multiplier
(number of zeros to follow)

M

Capacitance Tolerance
K = ±10%
M = ±20%
(For J = ±5% tolerance,
please consult factory)

035

Rated DC Voltage

SCS

Suffix indicating wire form
and packaging
(see page 3)

Dipped Radial Capacitors



TAP Series

TECHNICAL SPECIFICATIONS

Technical Data:		All technical data relate to an ambient temperature of +25°C							
Capacitance Range:		0.1μF to 330μF							
Capacitance Tolerance:		±20%; ±10% (±5% consult your AVX representative for details)							
Rated Voltage DC (V _R)	≤+85°C:	6.3	10	16	20	25	35	50	
Category Voltage (V _C)	≤+125°C:	4	6.3	10	13	16	23	33	
Surge Voltage (V _S)	≤+85°C:	8	13	20	26	33	46	65	
	≤+125°C:	5	9	12	16	21	28	40	
Temperature Range:		-55°C to +125°C							
Environmental Classification:		55/125/56 (IEC 68-2)							
Dissipation Factor:		≤0.04 for C _R 0.1-1.5μF							
		≤0.06 for C _R 2.2-6.8μF							
		≤0.08 for C _R 10-68μF							
		≤0.10 for C _R 100-330μF							
Reliability:		1% per 1000 hrs. at 85°C with 0.1Ω/V series impedance, 60% confidence level.							

Capacitance Range (letter denotes case code)								
Capacitance		Rated voltage DC (V _R)						
μF	Code	6.3V	10V	16V	20V	25V	35V	50V
0.1	104						A	A
0.15	154						A	A
0.22	224						A	A
0.33	334						A	A
0.47	474						A	A
0.68	684						A	B
1.0	105				A	A	A	C
1.5	155				A	A	A	D
2.2	225		A	A	A	A	B	E
3.3	335	A	A	A	B	B	C	F
4.7	475	A	A	B	C	C	E	G
6.8	685	A	B	C	D	D	F	H
10	106	B	C	D	E	E	F	J
15	156	C	D	E	F	F	H	K
22	226	D	E	F	H	H	K	L
33	336	E	F	F	J	J	M	
47	476	F	G	J	K	M	N	
68	686	G	H	L	N	N		
100	107	H	K	N	N			
150	157	K	N	N				
220	227	M	P	R				
330	337	P	R					

Values outside this standard range may be available on request.
 AVX reserves the right to supply capacitors to a higher voltage rating, in the same case size, than that ordered.

MARKING

Polarity, capacitance, rated DC voltage, and an "A" (AVX logo) are laser marked on the capacitor body which is made of flame retardant gold epoxy resin with a limiting oxygen index in excess of 30 (ASTM-D-2863).

- Polarity
- Capacitance
- Voltage
- AVX logo
- Tolerance code:
 - ±20% = Standard (no marking)
 - ±10% = "K" on reverse side of unit
 - ±5% = "J" on reverse side of unit

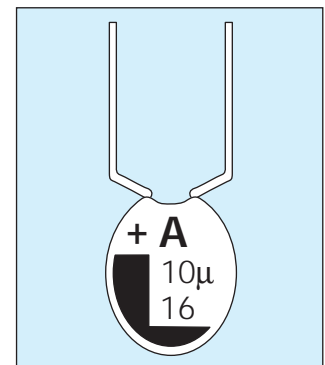

Dipped Radial Capacitors



TAP Series

RATINGS AND PART NUMBER REFERENCE

AVX Part No.	Case Size	Capacitance μ F	DCL (μ A) Max.	DF % Max.	ESR max. (Ω) @ 100 kHz
6.3 volt @ 85°C (4 volt @ 125°C)					
TAP 335(-)006	A	3.3	0.5	6	13.0
TAP 475(-)006	A	4.7	0.5	6	10.0
TAP 685(-)006	A	6.8	0.5	6	8.0
TAP 106(-)006	B	10	0.5	8	6.0
TAP 156(-)006	C	15	0.8	8	5.0
TAP 226(-)006	D	22	1.1	8	3.7
TAP 336(-)006	E	33	1.7	8	3.0
TAP 476(-)006	F	47	2.4	8	2.0
TAP 686(-)006	G	68	3.4	8	1.8
TAP 107(-)006	H	100	5.0	10	1.6
TAP 157(-)006	K	150	7.6	10	0.9
TAP 227(-)006	M	220	11.0	10	0.9
TAP 337(-)006	P	330	16.6	10	0.7
10 volt @ 85°C (6.3 volt @ 125°C)					
TAP 225(-)010	A	2.2	0.5	6	13.0
TAP 335(-)010	A	3.3	0.5	6	10.0
TAP 475(-)010	A	4.7	0.5	6	8.0
TAP 685(-)010	B	6.8	0.5	6	6.0
TAP 106(-)010	C	10	0.8	8	5.0
TAP 156(-)010	D	15	1.2	8	3.7
TAP 226(-)010	E	22	1.7	8	2.7
TAP 336(-)010	F	33	2.6	8	2.1
TAP 476(-)010	G	47	3.7	8	1.7
TAP 686(-)010	H	68	5.4	8	1.3
TAP 107(-)010	K	100	8.0	10	1.0
TAP 157(-)010	N	150	12.0	10	0.8
TAP 227(-)010	P	220	17.6	10	0.6
TAP 337(-)010	R	330	20.0	10	0.5
16 volt @ 85°C (10 volt @ 125°C)					
TAP 155(-)016	A	1.5	0.5	4	10.0
TAP 225(-)016	A	2.2	0.5	6	8.0
TAP 335(-)016	A	3.3	0.5	6	6.0
TAP 475(-)016	B	4.7	0.6	6	5.0
TAP 685(-)016	C	6.8	0.8	6	4.0
TAP 106(-)016	D	10	1.2	8	3.2
TAP 156(-)016	E	15	1.9	8	2.5
TAP 226(-)016	F	22	2.8	8	2.0
TAP 336(-)016	F	33	4.2	8	1.6
TAP 476(-)016	J	47	6.0	8	1.3
TAP 686(-)016	L	68	8.7	8	1.0
TAP 107(-)016	N	100	12.8	10	0.8
TAP 157(-)016	N	150	19.2	10	0.6
TAP 227(-)016	R	220	20.0	10	0.5
20 volt @ 85°C (13 volt @ 125°C)					
TAP 105(-)020	A	1.0	0.5	4	10.0
TAP 155(-)020	A	1.5	0.5	4	9.0
TAP 225(-)020	A	2.2	0.5	6	7.0
TAP 335(-)020	B	3.3	0.5	6	5.5
TAP 475(-)020	C	4.7	0.7	6	4.5
TAP 685(-)020	D	6.8	1.0	6	3.6
TAP 106(-)020	E	10	1.6	8	2.9
TAP 156(-)020	F	15	2.4	8	2.3
TAP 226(-)020	H	22	3.5	8	1.8

AVX Part No.	Case Size	Capacitance μ F	DCL (μ A) Max.	DF % Max.	ESR max. (Ω) @ 100 kHz
20 volt @ 85°C (13 volt @ 125°C) continued					
TAP 336(-)020	J	33	5.2	8	1.4
TAP 476(-)020	K	47	7.5	8	1.2
TAP 686(-)020	N	68	10.8	8	0.9
TAP 107(-)020	N	100	16.0	10	0.6
25 volt @ 85°C (16 volt @ 125°C)					
TAP 105(-)025	A	1.0	0.5	4	10.0
TAP 155(-)025	A	1.5	0.5	4	8.0
TAP 225(-)025	A	2.2	0.5	6	6.0
TAP 335(-)025	B	3.3	0.6	6	5.0
TAP 475(-)025	C	4.7	0.9	6	4.0
TAP 685(-)025	D	6.8	1.3	6	3.1
TAP 106(-)025	E	10	2.0	8	2.5
TAP 156(-)025	F	15	3.0	8	2.0
TAP 226(-)025	H	22	4.4	8	1.5
TAP 336(-)025	J	33	6.6	8	1.2
TAP 476(-)025	M	47	9.4	8	1.0
TAP 686(-)025	N	68	13.6	8	0.8
35 volt @ 85°C (23 volt @ 125°C)					
TAP 104(-)035	A	0.1	0.5	4	26.0
TAP 154(-)035	A	0.15	0.5	4	21.0
TAP 224(-)035	A	0.22	0.5	4	17.0
TAP 334(-)035	A	0.33	0.5	4	15.0
TAP 474(-)035	A	0.47	0.5	4	13.0
TAP 684(-)035	A	0.68	0.5	4	10.0
TAP 105(-)035	A	1.0	0.5	4	8.0
TAP 155(-)035	A	1.5	0.5	4	6.0
TAP 225(-)035	B	2.2	0.6	6	5.0
TAP 335(-)035	C	3.3	0.9	6	4.0
TAP 475(-)035	E	4.7	1.3	6	3.0
TAP 685(-)035	F	6.8	1.9	6	2.5
TAP 106(-)035	F	10	2.8	8	2.0
TAP 156(-)035	H	15	4.2	8	1.6
TAP 226(-)035	K	22	6.1	8	1.3
TAP 336(-)035	M	33	9.2	8	1.0
TAP 476(-)035	N	47	10.0	8	0.8
50 volt @ 85°C (33 volt @ 125°C)					
TAP 104(-)050	A	0.1	0.5	4	26.0
TAP 154(-)050	A	0.15	0.5	4	21.0
TAP 224(-)050	A	0.22	0.5	4	17.0
TAP 334(-)050	A	0.33	0.5	4	15.0
TAP 474(-)050	A	0.47	0.5	4	13.0
TAP 684(-)050	B	0.68	0.5	4	10.0
TAP 105(-)050	C	1.0	0.5	4	8.0
TAP 155(-)050	D	1.5	0.6	4	6.0
TAP 225(-)050	E	2.2	0.8	6	3.5
TAP 335(-)050	F	3.3	1.3	6	3.0
TAP 475(-)050	G	4.7	1.8	6	2.5
TAP 685(-)050	H	6.8	2.7	6	2.0
TAP 106(-)050	J	10	4.0	8	1.6
TAP 156(-)050	K	15	6.0	8	1.2
TAP 226(-)050	L	22	8.8	8	1.0

(*) Insert capacitance tolerance code: M for $\pm 20\%$, K for $\pm 10\%$ and J for $\pm 5\%$

NOTE: Voltage ratings are minimum values. AVX reserves the right to supply higher voltage ratings in the same case size.

Dipped Radial Capacitors

Tape and Reel Packaging

SOLID TANTALUM RESIN DIPPED TAP

TAPE AND REEL PACKAGING FOR AUTOMATIC COMPONENT INSERTION

TAP types are all offered on radial tape, in reel or 'ammo' pack format for use on high speed radial automatic insertion equipment, or preforming machines.

The tape format is compatible with EIA 468A standard for component taping set out by major manufacturers of radial automatic insertion equipment.

TAP – available in three formats. See page 8 for dimensions.

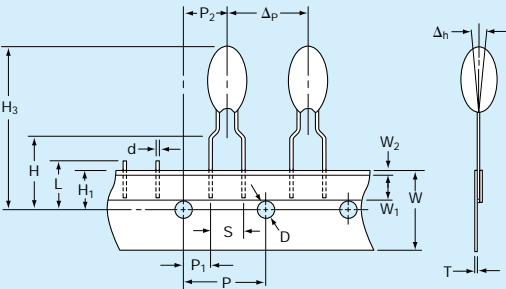

'B' wires for normal automatic insertion on 5mm pitch.

BRW suffix for reel
 BRS suffix for 'ammo' pack
 Available in case sizes A - J

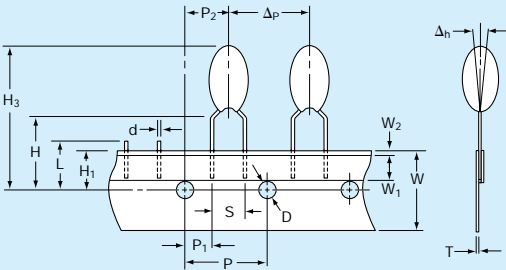

'C' wires for preforming.

CRW suffix for reel
 CRS suffix for 'ammo' pack
 Available in case sizes A - R

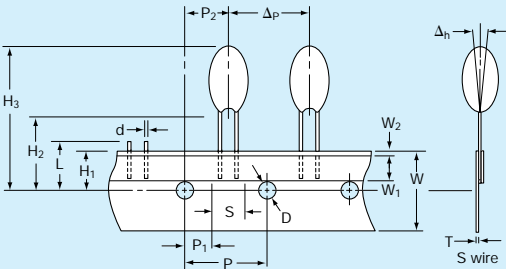

'S' and 'D' wire for special applications, automatic insertion on 2.5mm pitch.

SRW, DTW suffix for reel
 SRS, DTS suffix for 'ammo' pack
 Available in case sizes A - J

Note: Lead forms may vary slightly from those shown.

Dipped Radial Capacitors



Tape and Reel Packaging

SOLID TANTALUM RESIN DIPPED TAP

DIMENSIONS:

millimeters (inches)

Description	Code	Dimension
Feed hole pitch	P	12.7 ± 0.3 (0.5 ± 0.01)
Hole center to lead	P ₁	3.85 ± 0.7 (0.15 ± 0.03) to be measured at bottom of clench
		5.05 ± 1.0 (0.2 ± 0.04) for S wire
Hole center to component center	P ₂	6.35 ± 0.4 (0.25 ± 0.02)
Change in pitch	Δp	± 1.0 (± 0.04)
Lead diameter	d	0.5 ± 0.05 (0.02 ± 0.003)
Lead spacing	S	See wire form table
Component alignment	Δh	0 ± 2.0 (0 ± 0.08)
Feed hole diameter	D	4.0 ± 0.2 (0.15 ± 0.008)
Tape width	W	18.0 + 1.0 (0.7 + 0.04) - 0.5 - 0.02)
Hold down tape width	W ₁	6.0 (0.24) min.
Hold down tape position	W ₂	1.0 (0.04) max.
Lead wire clench height	H	16 ± 0.5 (0.63 ± 0.02)
		19 ± 1.0 (0.75 ± 0.04) on request
Hole position	H ₁	9.0 ± 0.5 (0.35 ± 0.02)
Base of component height	H ₂	18 (0.7) min. (S wire only)
Component height	H ₃	32.25 (1.3) max.
Length of snapped lead	L	11.0 (0.43) max.
Total tape thickness	T	0.7 ± 0.2 (0.03 ± 0.001)
		Carrying card 0.5 ± 0.1 (0.02 ± 0.005)

REEL CONFIGURATION AND DIMENSIONS:

millimeters (inches)

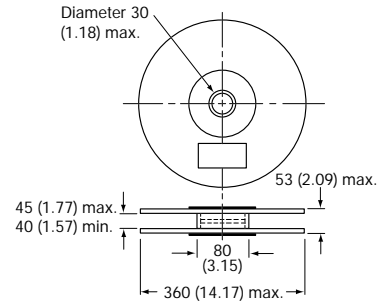

Manufactured from cardboard with plastic hub.

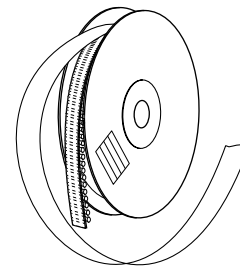

Holding tape outside. Positive terminal leading (negative terminal by special request).

PACKAGING QUANTITIES

For Reels

Style	Case code	No. of pieces
TAP	A	1500
	B, C, D	1250
	E, F	1000
	G, H, J	750
	K, L, M, N, P, R	500

For 'Ammo' pack

Style	Case code	No. of pieces
TAP	A, B, C, D	3000
	E, F, G	2500
	H, J	2000
	K, L, M, N, P, R	1000

For bulk products

Style	Case code	No. of pieces
TAP	A to H	1000
	J to L	500
	M to R	100

AMMO PACK DIMENSIONS

millimeters (inches) max.

Height 360 (14.17), width 360 (14.17), thickness 60 (2.36)

GENERAL NOTES

Resin dipped tantalum capacitors are only available taped in the range of case codes and in the modular quantities by case code as indicated.

Packaging quantities on tape may vary by ±1%.

Molded Axial Capacitors



TAR Series

SOLID TANTALUM MOLDED AXIAL LEADED CAPACITORS



TAR: Designed for use in miniature and subminiature circuit applications.

1. Precision molded and taped and reeled for use in high speed automatic insertion applications.
2. Suitable for decoupling, blocking, by-passing and filtering in computers, data processing, communications and other equipment.
3. Available in four case sizes.
4. Tapered nose identifies positive polarity.
5. Capacitance, tolerance, rated voltage and polarity are marked onto the capacitor body.
6. See page 15 for packaging quantities.

Case Dimensions: millimeters (inches)				
Case Size	L ±0.25 (0.010)	D ₁ ±0.25 (0.010)	d ±0.05 (0.002)	Typical Weight g
Q	6.35 (0.25)	2.16 (0.085)	0.5 (0.02)	0.20
R	7.4 (0.29)	2.5 (0.10)	0.5 (0.02)	0.25
S	8.6 (0.34)	4.3 (0.17)	0.5 (0.02)	0.52
W	10.4 (0.41)	4.3 (0.17)	0.5 (0.02)	0.53

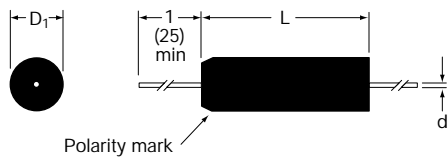

HOW TO ORDER

TAR

Type

R

Case Code

335

Capacitance Code
pF code: 1st two digits represent significant figures, 3rd digit represents multiplier (number of zeros to follow)

M

Capacitance Tolerance
K = ±10%
M = ±20%
(For J = ±5% tolerance, please consult factory)

015

Rated DC Voltage

Molded Axial Capacitors



TAR Series

TECHNICAL SPECIFICATIONS

Technical Data:		All technical data relate to an ambient temperature of +25°C							
Capacitance Range:		0.1μF to 68μF							
Capacitance Tolerance:		±20%; ±10%; ±5%							
Rated Voltage DC (V _R)	≅+85°C:	4	6.3	10	15	20	25	35	50
Category Voltage (V _C)	≅+125°C:	2.7	4	6.3	10	13	17	23	33
Surge Voltage (V _S)	≅+85°C:	5.2	8	13	20	26	33	46	65
	≅+125°C:	3.5	5	9	12	16	21	28	40
Temperature Range:		-55°C to +125°C							
Environmental Classification:		55/125/56 (IEC 68-2)							
Dissipation Factor:		See part number table							

Capacitance Range (letter denotes case code)								
Capacitance μF	Rated voltage DC (V _R)							
	4V	6.3V	10V	15V	20V	25V	35V	50V
0.1							Q	Q
0.15							Q	Q
0.22							Q	Q
0.33							Q	R
0.47						Q	Q	R
0.68						Q	R	R
1.0					Q	Q	R	R
1.5				Q	Q	R	R	S
2.2			Q	Q	R	R	S	S
3.3		Q	Q	R	R	R	S	W
4.7	Q	Q	R	R	R	S	S	W
6.8	Q	R	R	R	S	S	W	
10	R	R	R	S	S	S	W	
15	R	R	S	S	W	W		
22	R	S	S	W	W			
33	S	S	W	W				
47	S	W	W					
68	W	W						

Values outside this standard range may be available on request without appropriate release or qualification.

AVX reserves the right to supply capacitors to a tighter specification than that ordered.

MARKING

- Polarity
- Capacitance
- Date code
- Tolerance
- Voltage

Molded Axial Capacitors



TAR Series

RATINGS AND PART NUMBER REFERENCE

AVX Part No.	Case Size	Capacitance μF	DCL (μA) Max.	DF % Max.	ESR max. (Ω) @ 100 kHz
4 volt @ 85°C (2.7 volt @ 125°C)					
TARQ475(*)004	Q	4.7	0.5	8	12
TARQ685(*)004	Q	6.8	0.5	8	10
TARR106(*)004	R	10	0.5	8	10
TARR156(*)004	R	15	0.5	8	8.0
TARR226(*)004	R	22	0.7	8	6.0
TARS336(*)004	S	33	1.1	8	5.0
TARS476(*)004	S	47	1.5	8	3.5
TARW686(*)004	W	68	2.2	8	2.5
6.3 volt @ 85°C (4 volt @ 125°C)					
TARQ335(*)006	Q	3.3	0.5	4	14
TARQ475(*)006	Q	4.7	0.5	4	10
TARR685(*)006	R	6.8	0.5	6	8.0
TARR106(*)006	R	10	0.5	6	6.0
TARR156(*)006	R	15	0.7	6	5.0
TARS226(*)006	S	22	1.1	6	3.7
TARS336(*)006	S	33	1.5	6	3.0
TARW476(*)006	W	47	2.3	6	2.0
TARW686(*)006	W	68	3.3	6	1.8
10 volt @ 85°C (7 volt @ 125°C)					
TARQ225(*)010	Q	2.2	0.5	4	14
TARQ335(*)010	Q	3.3	0.5	4	10
TARR475(*)010	R	4.7	0.5	4	8.0
TARR685(*)010	R	6.8	0.5	6	6.0
TARR106(*)010	R	10	0.8	6	5.0
TARS156(*)010	S	15	1.2	6	3.7
TARS226(*)010	S	22	1.5	6	2.7
TARW336(*)010	W	33	2.6	6	2.1
TARW476(*)010	W	47	3.8	6	1.7
15 volt @ 85°C (10 volt @ 125°C)					
TARQ155(*)015	Q	1.5	0.5	4	14
TARQ225(*)015	Q	2.2	0.5	4	8.0
TARR335(*)015	R	3.3	0.5	4	6.0
TARR475(*)015	R	4.7	0.6	4	5.0
TARR685(*)015	R	6.8	0.8	6	4.0
TARS106(*)015	S	10	1.2	6	3.2
TARS156(*)015	S	15	1.5	6	2.5
TARW226(*)015	W	22	2.6	6	2.0
TARW336(*)015	W	33	4.0	6	1.6
20 volt @ 85°C (13 volt @ 125°C)					
TARQ105(*)020	Q	1.0	0.5	4	18
TARQ155(*)020	Q	1.5	0.5	4	12
TARR225(*)020	R	2.2	0.5	4	7.0
TARR335(*)020	R	3.3	0.5	4	5.5
TARR475(*)020	R	4.7	0.8	4	4.5
TARS685(*)020	S	6.8	1.1	6	3.7
TARS106(*)020	S	10	1.6	6	2.8
TARW156(*)020	W	15	2.4	6	2.3
TARW226(*)020	W	22	3.5	6	1.9

AVX Part No.	Case Size	Capacitance μF	DCL (μA) Max.	DF % Max.	ESR max. (Ω) @ 100 kHz
25 volt @ 85°C (17 volt @ 125°C)					
TARQ474(*)025	Q	0.47	0.5	3	20
TARQ684(*)025	Q	0.68	0.5	3	16
TARQ105(*)025	Q	1.0	0.5	3	12
TARR155(*)025	R	1.5	0.5	3	8.0
TARR225(*)025	R	2.2	0.5	3	6.0
TARR335(*)025	R	3.3	0.7	3	5.0
TARS475(*)025	S	4.7	0.9	4	4.0
TARS685(*)025	S	6.8	1.4	4	3.1
TARS106(*)025	S	10	1.5	4	2.5
TARW156(*)025	W	15	3.0	4	2.0
35 volt @ 85°C (23 volt @ 125°C)					
TARQ104(*)035	Q	0.1	0.5	3	26
TARQ154(*)035	Q	0.15	0.5	3	21
TARQ224(*)035	Q	0.22	0.5	3	17
TARQ334(*)035	Q	0.33	0.5	3	15
TARQ474(*)035	Q	0.47	0.5	3	13
TARR684(*)035	R	0.68	0.5	3	10
TARR105(*)035	R	1.0	0.5	3	8.0
TARR155(*)035	R	1.5	0.5	3	6.0
TARS225(*)035	S	2.2	0.6	3	5.0
TARS335(*)035	S	3.3	0.9	4	4.0
TARS475(*)035	S	4.7	1.3	4	3.0
TARW685(*)035	W	6.8	1.9	4	2.5
TARW106(*)035	W	10	2.8	4	2.0
50 volt @ 85°C (33 volt @ 125°C)					
TARQ104(*)050	Q	0.1	0.5	3	26
TARQ154(*)050	Q	0.15	0.5	3	21
TARQ224(*)050	Q	0.22	0.5	3	17
TARR334(*)050	R	0.33	0.5	3	15
TARR474(*)050	R	0.47	0.5	3	13
TARR684(*)050	R	0.68	0.5	3	10
TARR105(*)050	R	1.0	0.5	3	8.0
TARS155(*)050	S	1.5	0.6	4	5.0
TARS225(*)050	S	2.2	0.9	4	3.5
TARW335(*)050	W	3.3	1.3	4	3.0
TARW475(*)050	W	4.7	1.9	4	2.5

(*) Insert capacitance tolerance code; M for $\pm 20\%$, K for $\pm 10\%$ and J for $\pm 5\%$

NOTE: Voltage ratings are minimum values. AVX reserves the right to supply higher voltage ratings in the same case size.

Hermetic Axial Capacitors



TAA Series

SOLID TANTALUM HERMETICALLY SEALED AXIAL LEADED CAPACITORS



TAA: Fully hermetically sealed, of rugged construction and high reliability for use in military and professional equipment.

1. Extremely low leakage current.
2. Excellent capacitance to size ratio.
3. Available taped and reeled for automatic insertion.
4. Marked with AVX logo, capacitor type, capacitance, capacitance tolerance, rated voltage, polarity indication and date of manufacture.
5. Approved to BS CECC 30 201-001 and IECQ QC300 201 GB0002 supplied conforming to the limits of MIL-C-39003 style CSR, CTS 13 and CTS 32.

Case Dimensions: millimeters (inches)

Case Size	L ₁ max.	L ₂ max.	D max.	Lead Length min.	d nom.	Weight max. g
A	7.2 (0.28)	10.7 (0.42)	3.6 (0.14)	28 (1.1)	0.5	0.7
B	12.0 (0.47)	15.5 (0.61)	4.9 (0.19)	28 (1.1)	0.5	1.3
C	17.3 (0.68)	20.9 (0.82)	7.5 (0.29)	23 (0.9)	0.6	4.7
D	19.9 (0.78)	23.4 (0.92)	9.0 (0.35)	22 (0.8)	0.6	7.4

Note: The tabulated dimensions are for non-insulated capacitors. Insulated capacitors are standard, dimension L₁ will increase by 0.8mm maximum, and dimension D by 0.2mm maximum.

HOW TO ORDER

TAA

Type

A

Case Code

105

Capacitance Code
pF code:
1st two digits represent significant figures,
3rd digit represents multiplier (number of zeros to follow)

M

Capacitance Tolerance
K = ±10%
M = ±20%
(For J = ±5% tolerance, please consult factory)

035

Rated DC Voltage

G

TAA Packaging Suffixes
(see page 15)

Hermetic Axial Capacitors



TAA Series

TECHNICAL SPECIFICATIONS

Construction:	Hermetically sealed; axial terminations	Temperature Range:	-55°C to +125°C
Capacitance Range:	0.1µF to 330µF	Environmental Classification:	55/125/56 (IEC 68-2)
Capacitance Tolerance:	±20%; ±10%; ±5%	Dissipation Factor: (tan δ)	≅0.04 for C=0.1 to 4.7µF ≅0.06 for C= 6.8 to 100µF ≅0.08 for C= 150 to 330µF
Measuring Conditions:	120 Hz, 20°C	Approvals:	BS CECC 30 201-001 IEC QC 300 201 GB0002 CECC 30 201-005 CTS 13 CECC 30 201-019 CTS 32
Rated Voltage VDC	≅+85°C: 6.3 10 16 20 25 35 50		
Category Voltage VDC	≅+125°C: 4 6.3 10 13 17 23 33		
Surge Voltage VDC	≅+85°C: 8 13 20 26 33 46 65 ≅+125°C: 5 9 12 16 21 28 40		

Capacitance Range (letter denotes case code)								
Capacitance µF	Cap Code	Rated voltage DC						
		6.3V	10V	16V	20V	25V	35V	50V
0.1	104						A	A
0.15	154						A	A
0.22	224						A	A
0.33	334						A	A
0.47	474						A	A
0.68	684					A	A	A
1.0	105						A	A
1.5	155				A	A	B	B
2.2	225	A			A		B	B
3.3	335	A		A			B	B
4.7	475	A	A		B	B	B	B
6.8	685	A		B	B		B	C
10	106		B		B	B	C	C
15	156	B			B		C	C
22	226			B	C		C	D
33	336	B	B	C	C	C	D	
47	476	B	C	C	C		D	
68	686	C		C	D	D		
100	107		C	D	D			
150	157	C	D	D				
220	227	D	D					
330	337	D						

Hermetic Axial Capacitors



TAA Series

RATINGS AND PART NUMBER REFERENCE

AVX Part No.	Case Size	Capacitance μF	DCL (μA) Max.	DF % Max.	ESR max. (Ω) @ 100 kHz
6.3 volt @ 85°C (4 volt @ 125°C)					
TAAA225(*)006	A	2.2	0.5	4	N/A
TAAA335(*)006	A	3.3	0.5	4	N/A
TAAA475(*)006	A	4.7	0.5	4	N/A
TAAA685(*)006	A	6.8	0.5	6	5.0
TAAAB156(*)006	B	15	1.0	6	2.3
TAAAB336(*)006	B	3.3	1.0	6	2.0
TAAAB476(*)006	B	47	3.0	6	1.6
TAAAC686(*)006	C	68	4.5	6	1.0
TAAAC157(*)006	C	150	9.5	8	0.8
TAAAD227(*)006	D	220	14.0	8	0.6
TAAAD337(*)006	D	330	20.0	8	0.5
10 volt @ 85°C (6.3 volt @ 125°C)					
TAAA475(*)010	A	4.7	0.5	6	5.0
TAAAB106(*)010	B	10	1.0	6	2.6
TAAAB336(*)010	B	33	3.5	6	1.6
TAAAC476(*)010	C	47	3.0	6	1.1
TAAAC107(*)010	C	100	10.0	6	1.0
TAAAD157(*)010	D	150	15.0	8	0.8
TAAAD227(*)010	D	220	20.0	8	0.5
16 volt @ 85°C (10 volt @ 125°C)					
TAAA335(*)016	A	3.3	0.5	6	6.0
TAAAB685(*)016	B	6.8	0.8	6	2.5
TAAAB156(*)016	B	15	2.4	6	2.0
TAAAB226(*)016	B	22	3.5	6	1.6
TAAAC336(*)016	C	33	5.8	6	1.2
TAAAC476(*)016	C	47	7.3	6	1.0
TAAAC686(*)016	C	68	10.0	6	0.8
TAAAD107(*)016	D	100	15.0	6	0.7
TAAAD157(*)016	D	150	20.0	8	0.5
20 volt @ 85°C (13 volt @ 125°C)					
TAAA155(*)020	A	1.5	0.5	4	9.0
TAAA225(*)020	A	2.2	0.5	4	6.5
TAAAB475(*)020	B	4.7	0.8	4	3.0
TAAAB685(*)020	B	6.8	1.0	6	2.5
TAAAB106(*)020	B	10	2.0	6	2.6
TAAAB156(*)020	B	15	3.0	6	1.8
TAAAB156(*)020	B	15	3.0	6	2.3
TAAAC226(*)020	C	22	4.5	6	1.3
TAAAC336(*)020	C	33	7.0	6	1.2
TAAAC476(*)020	C	47	9.5	6	0.9
TAAAD686(*)020	D	68	13.5	6	0.8
TAAAD107(*)020	D	100	20.0	6	0.5

AVX Part No.	Case Size	Capacitance μF	DCL (μA) Max.	DF % Max.	ESR max. (Ω) @ 100 kHz
25 volt @ 85°C (17 volt @ 125°C)					
TAAA684(*)025	A	6.8	0.5	4	9.5
TAAA155(*)025	A	1.5	0.5	4	7.5
TAAAB475(*)025	B	4.7	1.2	4	2.8
TAAAB106(*)025	B	10	2.5	6	2.0
TAAAC336(*)025	C	33	8.5	6	1.0
TAAAD686(*)025	D	68	15.0	6	0.6
35 volt @ 85°C (23 volt @ 125°C)					
TAAA104(*)035	A	0.10	0.5	4	N/A
TAAA154(*)035	A	0.15	0.5	4	N/A
TAAA224(*)035	A	0.22	0.5	4	N/A
TAAA334(*)035	A	0.33	0.5	4	N/A
TAAA474(*)035	A	0.47	0.5	4	N/A
TAAA684(*)035	A	0.68	0.5	4	10.0
TAAA105(*)035	A	1.0	0.5	4	8.0
TAAAB155(*)035	B	1.5	0.5	4	6.0
TAAAB225(*)035	B	2.2	1.0	4	6.0
TAAAB335(*)035	B	3.3	1.0	4	3.5
TAAAB475(*)035	B	4.7	1.5	4	2.5
TAAAB685(*)035	B	6.8	2.5	6	2.0
TAAAC106(*)035	C	10	3.5	6	1.6
TAAAC156(*)035	C	15	5.0	6	1.2
TAAAC226(*)035	C	22	7.5	6	1.0
TAAAD336(*)035	D	33	10.0	6	0.8
TAAAD476(*)035	D	47	10.0	6	0.6
50 volt @ 85°C (33 volt @ 125°C)					
TAAA104(*)050	A	0.10	0.5	4	N/A
TAAA154(*)050	A	0.15	0.5	4	N/A
TAAA224(*)050	A	0.22	0.5	4	N/A
TAAA334(*)050	A	0.33	0.5	4	N/A
TAAA474(*)050	A	0.47	0.5	4	N/A
TAAA684(*)050	A	0.68	0.5	4	10.0
TAAA105(*)050	A	1.0	0.5	4	8.0
TAAAB155(*)050	B	1.5	0.8	4	6.0
TAAAB225(*)050	B	2.2	1.1	6	6.0
TAAAB335(*)050	B	3.3	1.7	6	3.5
TAAAB475(*)050	B	4.7	2.4	6	2.5
TAAAC685(*)050	C	6.8	3.4	6	2.0
TAAAC106(*)050	C	10	5.0	6	1.6
TAAAC156(*)050	C	15	7.5	6	1.2
TAAAD226(*)050	D	22	11.0	6	1.0

(*) Insert capacitance tolerance code; M for $\pm 20\%$, K for $\pm 10\%$ and J for $\pm 5\%$

NOTE: Voltage ratings are minimum values. AVX reserves the right to supply higher voltage ratings in the same case size.

Axial Capacitors



Tape and Reel Packaging

SOLID TANTALUM AXIAL TAR AND TAA

TAPE AND REEL PACKAGING FOR AUTOMATIC COMPONENT INSERTION

TAR and TAA series are supplied as standard on axial bandolier, in reel format or 'ammo' pack for use on high speed axial automatic insertion equipment, or preforming machines.

The tape format is compatible with standards for component taping set out by major manufacturers of axial automatic insertion equipment.

TAPE SPECIFICATION

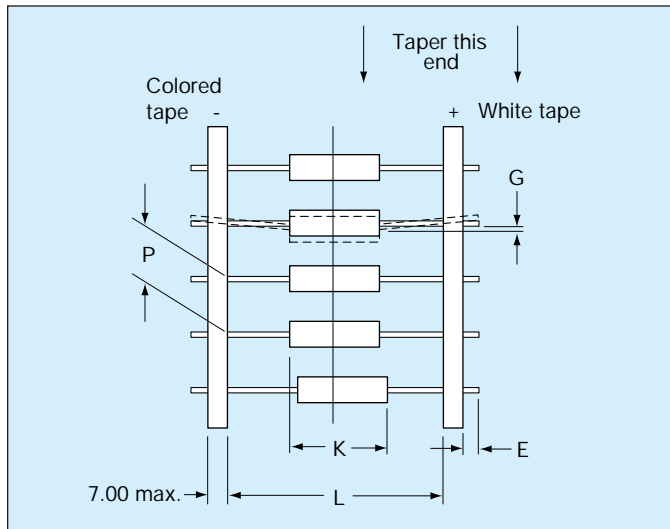

REEL CONFIGURATION

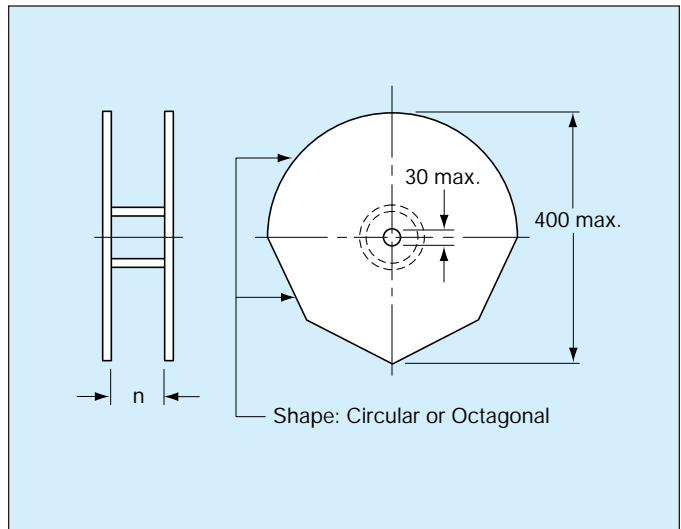

PACKAGING QUANTITIES TAR

For reels

Case Code	Number of Pieces
Q	3000
R	3000
S	2000
W	2000

PACKAGING QUANTITIES TAA

For reels, Standard Suffix G

Case Code	Number of Pieces
A	3500
B	2500
C	500
D	400

For ammo pack, Standard Suffix W

Case Code	Number of Pieces
A	1500
B	1000
C	250
D	250

DIMENSIONS:

millimeters (inches)

E max	1.6 (0.063)
G max	1.2 (0.047)
K	Component body shall be located centrally within a window, width K, where K is 1.4 (0.06) greater than the primary body length
L	52.4 ± 1.5 (2.06 ± 0.06)
P	5.0 ± 0.5 (0.2 ± 0.02)
leader max	400 (15.75)
trailer max	30 (1.2)
n	Will allow for unhindered reeling and unreeling of the taped components

PREFERRED DIMENSIONS:

millimeters (inches)

G - Taped, Reeled	73.0 (2.87) Spacing
W - Taped, Ammo Pack	73.0 (2.87) Spacing



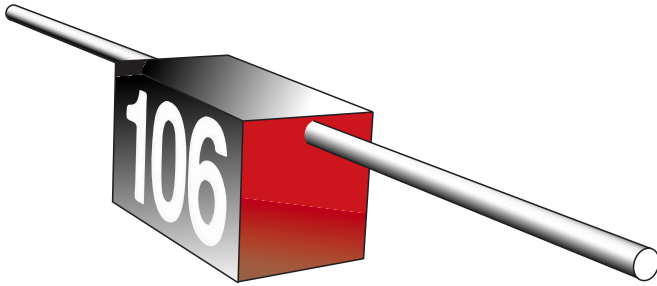

The TMH series is now available in three case sizes. These precision microminiature polarized capacitors are especially suitable for general filtering, decoupling, bypassing and RC timing applications. The TMH series is rated to +85°C without derating and up to +125°C with derating. The favorable capacitance to volume ratio has made this series of MINITAN capacitors the leader in high density applications such as hearing aids.

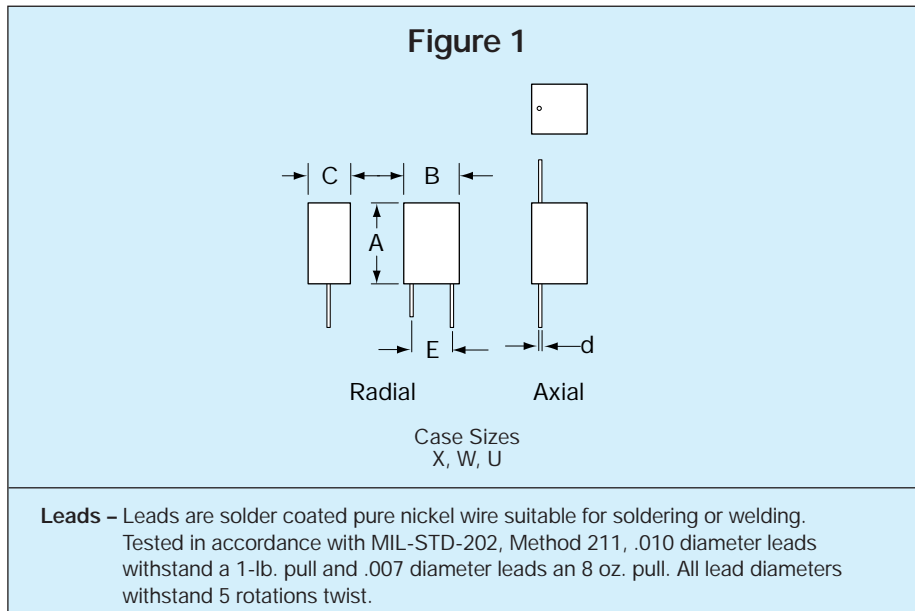

Case Dimensions — millimeters (inches)					
Case Size	A Max	B Max	C Max	d ±.025 (0.001)	E
X	1.9 (.075)	1.3 (.050)	1.1 (.040)	.178 (.007)	0.8±0.4 (.030±.015)
W	2.5 (.100)	1.3 (.050)	1.1 (.040)	.178 (.007)	0.8±0.4 (.030±.015)
U	3.2 (.125)	1.8 (.070)	1.1 (.040)	.254 (.010)	1.3±0.4 (.050±.015)
Lead length: all case sizes:		Pos. 41.3±3.2 (1.625±.125) Neg. 34.9±3.2 (1.375±.125)			

TMH Series

TECHNICAL SPECIFICATIONS

Technical Data:	All technical data relate to an ambient temperature of +25°C							
Capacitance Range:	0.001μF to 10μF							
Capacitance Tolerance:	±20%; ±10%; ±5%							
Rated Voltage DC (V _R)	≤+85°C:	2	3	4	6	10	15	20
Category Voltage (V _C)	≤+125°C:	1.3	2	2.6	4	6.7	10	13
Surge Voltage (V _S)	≤+85°C:	2.6	4	5.2	8	13	19	26
	≤+125°C:	1.7	2.6	3.4	5.2	8.7	13	16
Temperature Range:	-55°C to +125°C							
Dissipation Factor:	see part number table							
Life Test:	After 2000 hrs. at 85°C with V _R applied. ΔCAP = ±15% max. ΔDF, DCL = initial limit.							

HOW TO ORDER

TMH

Type

W

Case Code
(See table on page 16)

472

Capacitance Code
pF code: 1st two digits represent significant figures, 3rd digit represents multiplier (number of zeros to follow)

M

Tolerance
J = ±5%
K = ±10%
M = ±20%

020

Rated DC Voltage

R

Lead Configuration
R = Radial
A = Axial

B

Packaging
B = Bulk
(100 pcs per bag)

SZ0000

Other Product Information
SZ = Standard Product
0000 = Standard Product

*Note: Other digits may be supplied by factory to identify specific customer requirements. Contact factory for details.

MARKING

Capacitance value shall be typographically marked on all case sizes.

- Capacitance
- Polarity
- Radial = Red dot on top of unit
- Axial = Red end
- Tolerance code:
 - ±20% = Standard (no marking)
 - ±10% = Silver dot
 - ±5% = Gold dot

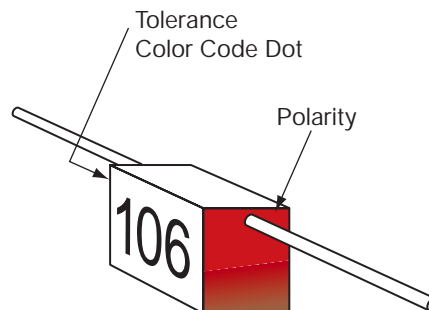
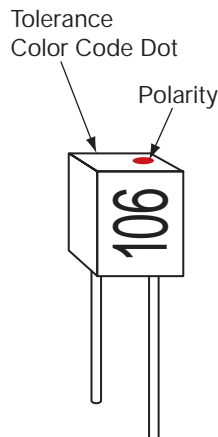

RATINGS AND PART NUMBER REFERENCE

AVX Part No.	Capacitance μF	DCL (μA) Max.	DF % Max.
2 volt @ 85°C (1.3 volt @ 125°C)			
TMH-X-474(+)002 \emptyset	0.47	0.5	15
TMH-W-474(+)002 \emptyset	0.47	0.5	15
TMH-X-684(+)002 \emptyset	0.68	0.5	15
TMH-W-684(+)002 \emptyset	0.68	0.5	15
TMH-X-105(+)002 \emptyset	1.0	0.5	15
TMH-W-105(+)002 \emptyset	1.0	0.5	15
TMH-X-155(+)002 \emptyset	1.5	0.5	15
TMH-X-225(+)002 \emptyset	2.2	0.5	15
TMH-W-225(+)002 \emptyset	2.2	0.5	15
TMH-U-225(+)002 \emptyset	2.2	0.5	15
TMH-U-335(+)002 \emptyset	3.3	0.5	15
TMH-U-475(+)002 \emptyset	4.7	0.5	15
TMH-U-685(+)002 \emptyset	6.8	0.5	15
TMH-U-106(+)002 \emptyset	10.0	0.5	15
3 volt @ 85°C (2 volt @ 125°C)			
TMH-U-155(+)003 \emptyset	1.5	0.5	10
TMH-U-475(+)003 \emptyset	4.7	0.5	10
4 volt @ 85°C (2.6 volt @ 125°C)			
TMH-X-334(+)004 \emptyset	0.33	0.5	10
TMH-W-334(+)004 \emptyset	0.33	0.5	10
TMH-U-105(+)004 \emptyset	1.0	0.5	10
6 volt @ 85°C (4 volt @ 125°C)			
TMH-X-224(+)006 \emptyset	0.22	0.5	10
TMH-W-224(+)006 \emptyset	0.22	0.5	10
TMH-U-684(+)006 \emptyset	0.68	0.5	10
10 volt @ 85°C (6.7 volt @ 125°C)			
TMH-X-154(+)010 \emptyset	0.15	0.5	10
TMH-W-154(+)010 \emptyset	0.15	0.5	10
TMH-U-474(+)010 \emptyset	0.47	0.5	10
15 volt @ 85°C (10 volt @ 125°C)			
TMH-X-104(+)015 \emptyset	0.1	0.5	10
TMH-W-104(+)015 \emptyset	0.1	0.5	10
TMH-U-334(+)015 \emptyset	0.33	0.5	10

AVX Part No.	Capacitance μF	DCL (μA) Max.	DF % Max.
20 volt @ 85°C (13 volt @ 125°C)			
TMH-U-102(+)020 \emptyset	0.001	0.5	10
TMH-U-152(+)020 \emptyset	0.0015	0.5	10
TMH-X-222(+)020 \emptyset	0.0022	0.5	10
TMH-W-222(+)020 \emptyset	0.0022	0.5	10
TMH-U-222(+)020 \emptyset	0.0022	0.5	10
TMH-X-332(+)020 \emptyset	0.0033	0.5	10
TMH-W-332(+)020 \emptyset	0.0033	0.5	10
TMH-U-332(+)020 \emptyset	0.0033	0.5	10
TMH-X-472(+)020 \emptyset	0.0047	0.5	10
TMH-W-472(+)020 \emptyset	0.0047	0.5	10
TMH-U-472(+)020 \emptyset	0.0047	0.5	10
TMH-X-682(+)020 \emptyset	0.0068	0.5	10
TMH-W-682(+)020 \emptyset	0.0068	0.5	10
TMH-U-682(+)020 \emptyset	0.0068	0.5	10
TMH-X-103(+)020 \emptyset	0.010	0.5	10
TMH-W-103(+)020 \emptyset	0.010	0.5	10
TMH-U-103(+)020 \emptyset	0.010	0.5	10
TMH-U-153(+)020 \emptyset	0.015	0.5	10
TMH-X-153(+)020 \emptyset	0.015	0.5	10
TMH-W-153(+)020 \emptyset	0.015	0.5	10
TMH-X-223(+)020 \emptyset	0.022	0.5	10
TMH-W-223(+)020 \emptyset	0.022	0.5	10
TMH-U-223(+)020 \emptyset	0.022	0.5	10
TMH-X-333(+)020 \emptyset	0.033	0.5	10
TMH-W-333(+)020 \emptyset	0.033	0.5	10
TMH-U-333(+)020 \emptyset	0.033	0.5	10
TMH-X-473(+)020 \emptyset	0.047	0.5	10
TMH-W-473(+)020 \emptyset	0.047	0.5	10
TMH-U-473(+)020 \emptyset	0.047	0.5	10
TMH-X-683(+)020 \emptyset	0.068	0.5	10
TMH-W-683(+)020 \emptyset	0.068	0.5	10
TMH-U-683(+)020 \emptyset	0.068	0.5	10
TMH-U-104(+)020 \emptyset	0.1	0.5	10
TMH-U-154(+)020 \emptyset	0.15	0.5	10
TMH-U-224(+)020 \emptyset	0.22	0.5	10

\emptyset Insert Lead Style: R = Radial, A = Axial

(+) Insert Capacitance Tolerance: M=±20%; K=±10%; J=±5%

Technical Summary and Application Guidelines

CONTENTS

- Section 1:** Electrical Characteristics and Explanation of Terms.
- Section 2:** A.C. Operation and Ripple Voltage.
- Section 3:** Reliability and Calculation of Failure Rate.
- Section 4:** Application Guidelines for Tantalum Capacitors.
- Section 5:** Mechanical and Thermal Properties of Leaded Capacitors.
- Section 6:** Qualification approval status.

INTRODUCTION

Tantalum capacitors are manufactured from a powder of pure tantalum metal. The typical particle size is between 2 and 10 μm .

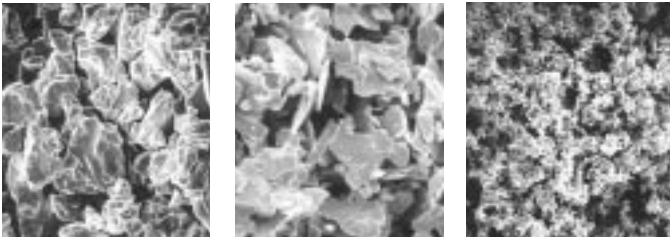

4000 μFV

10000 μFV

20000 μFV

The powder is compressed under high pressure around a Tantalum wire to form a 'pellet'. The riser wire is the anode connection to the capacitor.

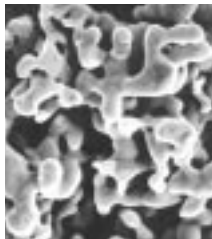

This is subsequently vacuum sintered at high temperature (typically 1500 - 2000°C). This helps to drive off any impurities within the powder by migration to the surface.

During sintering the powder becomes a sponge like structure with all the particles interconnected in a huge lattice. This structure is of high mechanical strength and density, but is also highly porous giving a large internal surface area.

The larger the surface area the larger the capacitance. Thus high CV (capacitance/voltage product) powders, which have a low average particle size, are used for low voltage, high capacitance parts. The figure below shows typical powders. Note the very great difference in particle size between the powder CVs.

By choosing which powder is used to produce each capacitance/voltage rating the surface area can be controlled.

The following example uses a 22 μF 25V capacitor to illustrate the point.

$$C = \frac{\epsilon_0 \epsilon_r A}{d}$$

- where ϵ_0 is the dielectric constant of free space (8.855 x 10⁻¹² Farads/m)
- ϵ_r is the relative dielectric constant for Tantalum Pentoxide (27)
- d is the dielectric thickness in meters (for a typical 25V part)
- C is the capacitance in Farads
- and A is the surface area in meters

Rearranging this equation gives

$$A = \frac{Cd}{\epsilon_0 \epsilon_r}$$

thus for a 22 μF /25V capacitor the surface area is 150 square centimeters, or nearly 1/2 the size of this page.

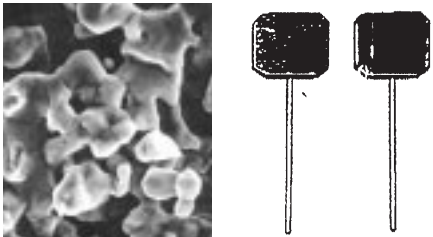

The dielectric is then formed over all the tantalum surfaces by the electrochemical process of anodization. The 'pellet' is dipped into a very weak solution of phosphoric acid. The dielectric thickness is controlled by the voltage applied during the forming process. Initially the power supply is kept in a constant current mode until the correct thickness of dielectric has been reached (that is the voltage reaches the 'forming voltage'), it then switches to constant voltage mode and the current decays to close to zero.

The chemical equations describing the process are as follows:

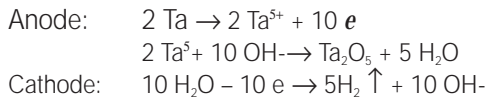

The oxide forms on the surface of the Tantalum but it also grows into the metal. For each unit of oxide two thirds grows out and one third grows in. It is for this reason that there is a limit on the maximum voltage rating of Tantalum capacitors with present technology powders.

The dielectric operates under high electrical stress. Consider a 22 μF 25V part:

Formation voltage = Formation Ratio x Working Voltage
 = 4 x 25
 = 100 Volts

Technical Summary and Application Guidelines

The pentoxide (Ta_2O_5) dielectric grows at a rate of 1.7×10^{-9} m/V

$$\begin{aligned} \text{Dielectric thickness (d)} &= 100 \times 1.7 \times 10^{-9} \\ &= 0.17 \mu\text{m} \end{aligned}$$

$$\begin{aligned} \text{Electric Field strength} &= \text{Working Voltage} / d \\ &= 147 \text{ KV/mm} \end{aligned}$$

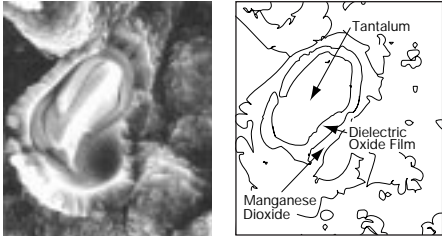
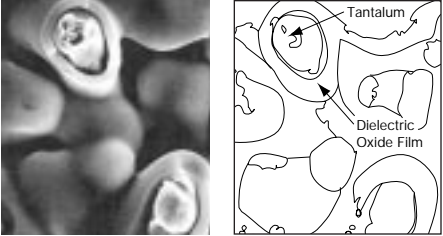

The next stage is the production of the cathode plate. This is achieved by pyrolysis of Manganese Nitrate into Manganese Dioxide.

The 'pellet' is dipped into an aqueous solution of Nitrate and then baked in an oven at approximately 250°C to produce to Dioxide coat. The chemical equation is



This process is repeated several times through varying specific densities of Nitrate to build up a thick coat over all internal and external surfaces of the 'pellet', as shown in the figure.

The 'pellet' is then dipped into graphite and silver to provide a good connection to the Manganese Dioxide cathode plate. Electrical contact is established by deposition of carbon onto the surface of the cathode. The carbon is then coated with a conductive material to facilitate connection to the cathode termination. Packaging is carried out to meet individual specifications and customer requirements. This manufacturing technique is adhered to for the whole range of AVX tantalum capacitors, which can be subdivided into four basic groups:

Chip / Resin dipped / Rectangular boxed / Axial

For further information on production of Tantalum Capacitors see the technical paper "Basic Tantalum Technology", by John Gill, available from your local AVX representative.

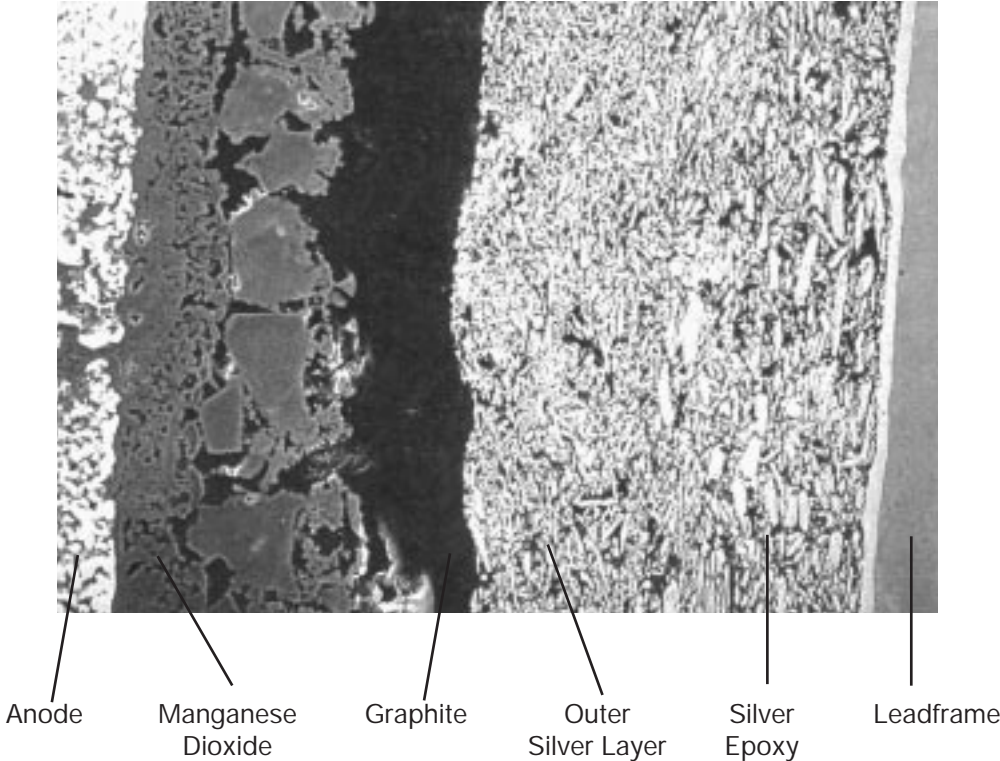

Technical Summary and Application Guidelines



SECTION 1: ELECTRICAL CHARACTERISTICS AND EXPLANATION OF TERMS

1.1 CAPACITANCE

1.1.1 Rated capacitance (C_R)

This is the nominal rated capacitance. For tantalum capacitors it is measured as the capacitance of the equivalent series circuit at 20°C in a measuring bridge supplied by a 120 Hz source free of harmonics with 2.2V DC bias max.

1.1.2 Temperature dependence on the capacitance

The capacitance of a tantalum capacitor varies with temperature. This variation itself is dependent to a small extent on the rated voltage and capacitor size. See graph below for typical capacitance changes with temperature.

TYPICAL CAPACITANCE vs. TEMPERATURE

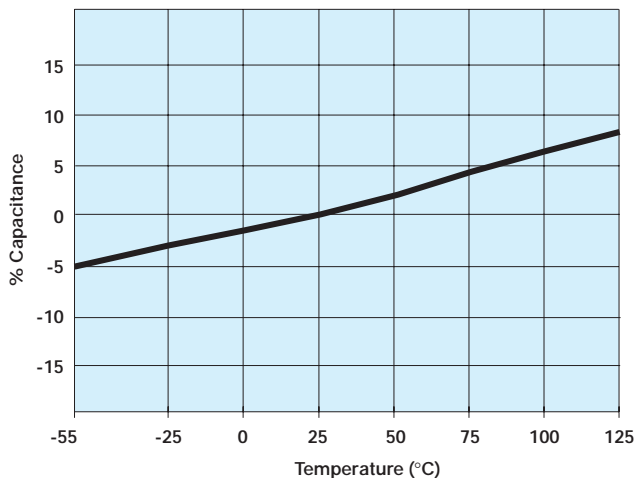

1.1.3 Capacitance tolerance

This is the permissible variation of the actual value of the capacitance from the rated value.

1.1.4 Frequency dependence of the capacitance

The effective capacitance decreases as frequency increases. Beyond 100 kHz the capacitance continues to drop until resonance is reached (typically between 0.5-5 MHz depending on the rating). Beyond this the device becomes inductive.

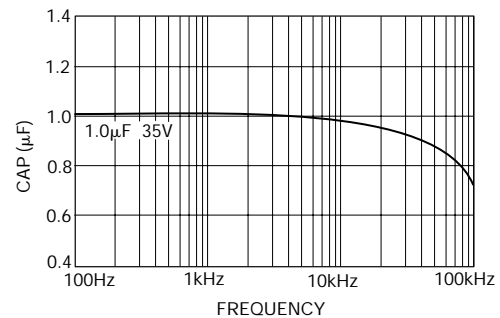

1.2 VOLTAGE

1.2.1 Rated DC voltage (V_R)

This is the rated DC voltage for continuous operation up to +85°C.

1.2.2 Category voltage (V_C)

This is the maximum voltage that may be applied continuously to a capacitor. It is equal to the rated voltage up to +85°C, beyond which it is subject to a linear derating, to 2/3 V_R at 125°C.

1.2.3 Surge voltage (V_S)

This is the highest voltage that may be applied to a capacitor for short periods of time. The surge voltage may be applied up to 10 times in an hour for periods of up to 30 seconds at a time. The surge voltage must not be used as a parameter in the design of circuits in which, in the normal course of operation, the capacitor is periodically charged and discharged.

Typical Curve Capacitance vs. Frequency

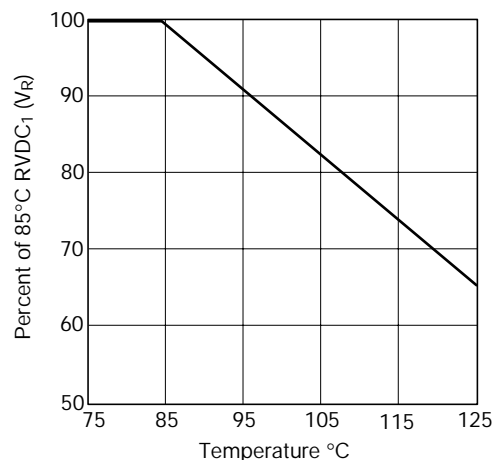

Technical Summary and Application Guidelines



85°C		125°C	
Rated Voltage (V DC)	Surge Voltage (V DC)	Category Voltage (V DC)	Surge Voltage (V DC)
2	2.6	1.3	1.7
3	4	2	2.6
4	5.2	2.6	3.4
6.3	8	4	5
10	13	6.3	9
16	20	10	12
20	26	13	16
25	33	16	21
35	46	23	28
50	65	33	40

1.2.4 Effect of surges

The solid Tantalum capacitor has a limited ability to withstand surges (15% to 30% of rated voltage). This is in common with all other electrolytic capacitors and is due to the fact that they operate under very high electrical stress within the oxide layer. In the case of 'solid' electrolytic capacitors this is further complicated by the limited self healing ability of the manganese dioxide semiconductor.

It is important to ensure that the voltage across the terminals of the capacitor does not exceed the surge voltage rating at any time. This is particularly so in low impedance circuits where the capacitor is likely to be subjected to the full impact of surges, especially in low inductance applications. Even an extremely short duration spike is likely to cause damage. In such situations it will be necessary to use a higher voltage rating.

1.3 DISSIPATION FACTOR AND TANGENT OF LOSS ANGLE (TAN δ)

1.3.1 Dissipation factor (DF)

Dissipation factor is the measurement of the tangent of the loss angle (Tan δ) expressed as a percentage.

The measurement of DF is carried out at +25°C and 120 Hz with 2.2V DC bias max. with an AC voltage free of harmonics. The value of DF is temperature and frequency dependent.

1.3.2 Tangent of loss angle (Tan δ)

This is a measure of the energy loss in the capacitor. It is expressed as Tan δ and is the power loss of the capacitor divided by its reactive power at a sinusoidal voltage of specified frequency. (Terms also used are power factor, loss factor and dielectric loss, Cos (90 - δ) is the true power factor.) The measurement of Tan δ is carried out at +20°C and 120 Hz with 2.2V DC bias max. with an AC voltage free of harmonics.

1.2.5 Reverse voltage and non-polar operation

The reverse voltage ratings are designed to cover exceptional conditions of small level excursions into incorrect polarity. The values quoted are not intended to cover continuous reverse operation.

The peak reverse voltage applied to the capacitor must not exceed:

- 10% of rated DC working voltage to a maximum of 1V at 25°C

- 3% of rated DC working voltage to a maximum of 0.5V at 85°C

- 1% of category DC working voltage to a maximum of 0.1V at 125°C

1.2.6 Non-polar operation

If the higher reverse voltages are essential, then two capacitors, each of twice the required capacitance and of equal tolerance and rated voltage, should be connected in a back-to-back configuration, i.e., both anodes or both cathodes joined together. This is necessary in order to avoid a reduction in life expectancy.

1.2.7 Superimposed AC voltage (V_{rms}) - Ripple Voltage

This is the maximum RMS alternating voltage, superimposed on a DC voltage, that may be applied to a capacitor. The sum of the DC voltage and the surge value of the superimposed AC voltage must not exceed the category voltage, V_c . Full details are given in Section 2.

1.2.8 Voltage derating

Refer to section 3.2 (page 27) for the effect of voltage derating on reliability.

1.3.3 Frequency dependence of dissipation factor

Dissipation Factor increases with frequency as shown in the typical curves below.

Typical Curve-Dissipation Factor vs. Frequency

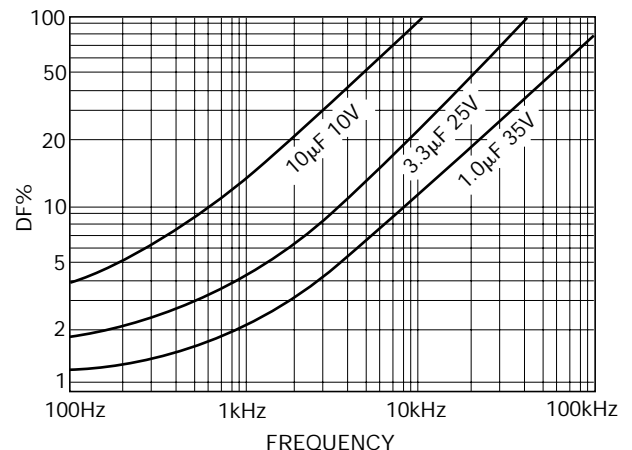

Technical Summary and Application Guidelines



1.3.4 Temperature dependence of dissipation factor

Dissipation factor varies with temperature as the typical curves show to the right. For maximum limits please refer to ratings tables.

Typical Curves-Dissipation Factor vs. Temperature

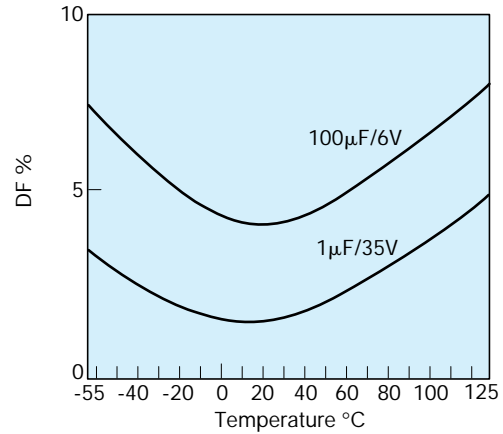

1.4 IMPEDANCE, (Z) AND EQUIVALENT SERIES RESISTANCE (ESR)

1.4.1 Impedance, Z

This is the ratio of voltage to current at a specified frequency. Three factors contribute to the impedance of a tantalum capacitor; the resistance of the semiconducting layer, the capacitance, and the inductance of the electrodes and leads.

At high frequencies the inductance of the leads becomes a limiting factor. The temperature and frequency behavior of these three factors of impedance determine the behavior of the impedance Z. The impedance is measured at 25°C and 100 kHz.

1.4.2 Equivalent series resistance, ESR

Resistance losses occur in all practical forms of capacitors. These are made up from several different mechanisms, including resistance in components and contacts, viscous forces within the dielectric, and defects producing bypass current paths. To express the effect of these losses they are considered as the ESR of the capacitor. The ESR is frequency dependent. The ESR can be found by using the relationship:

$$ESR = \frac{\tan \delta}{2\pi f C}$$

where f is the frequency in Hz, and C is the capacitance in farads. The ESR is measured at 25°C and 100 kHz.

ESR is one of the contributing factors to impedance, and at high frequencies (100 kHz and above) is the dominant factor, so that ESR and impedance become almost identical, impedance being marginally higher.

1.4.3 Frequency dependence of impedance and ESR

ESR and impedance both increase with decreasing frequency. At lower frequencies the values diverge as the extra contributions to impedance (resistance of the semiconducting layer, etc.) become more significant. Beyond 1 MHz (and beyond the resonant point of the capacitor) impedance again increases due to induction.

Frequency Dependence of Impedance and ESR

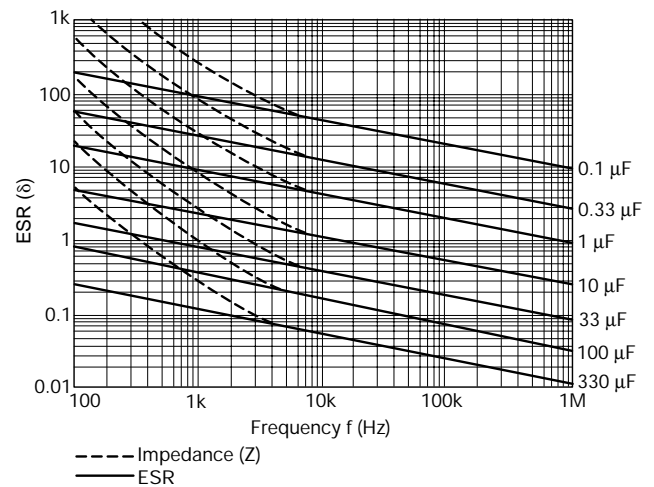

Technical Summary and Application Guidelines



1.4.4 Temperature dependence of the impedance and ESR

At 100 kHz, impedance and ESR behave identically and decrease with increasing temperature as the typical curves show. For maximum limits at high and low temperatures, please refer to graph opposite.

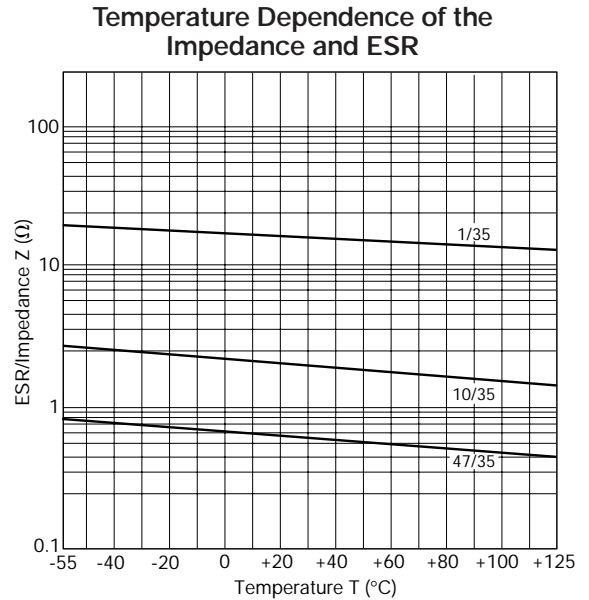

1.5 DC LEAKAGE CURRENT (DCL)

1.5.1 Leakage current (DCL)

The leakage current is dependent on the voltage applied, the time, and the capacitor temperature. It is measured at +25°C with the rated voltage applied. A protective resistance of 1000Ω is connected in series with the capacitor in the measuring circuit.

Three minutes after application of the rated voltage the leakage current must not exceed the maximum values indicated in the ratings table. Reforming is unnecessary even after prolonged periods without the application of voltage.

1.5.2 Temperature dependence of the leakage current

The leakage current increases with higher temperatures, typical values are shown in the graph.

For operation between 85°C and 125°C, the maximum working voltage must be derated and can be found from the following formula.

$$V_{\max} = \left(1 - \frac{T-85}{120}\right) \times V_R \text{ volts}$$

where T is the required operating temperature. Maximum limits are given in rating tables.

1.5.3 Voltage dependence of the leakage current

The leakage current drops rapidly below the value corresponding to the rated voltage V_R when reduced voltages are applied. The effect of voltage derating on the leakage current is shown in the graph.

This will also give a significant increase in reliability for any application. See Section 3 for details.

1.5.4 Ripple current

The maximum ripple current allowance can be calculated from the power dissipation limits for a given temperature rise above ambient. Please refer to Section 2 for details.

Temperature Dependence of the Leakage Current for a Typical Component

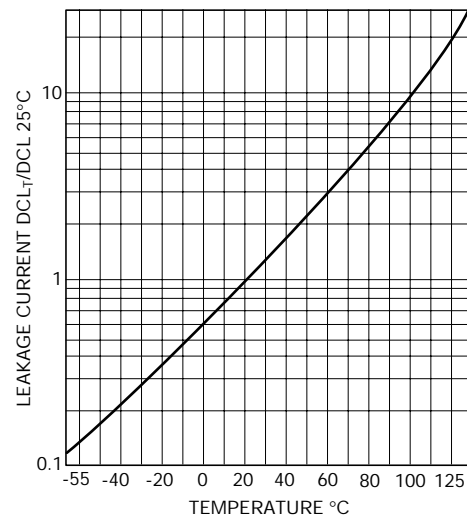

Effect of Voltage Derating on Leakage Current

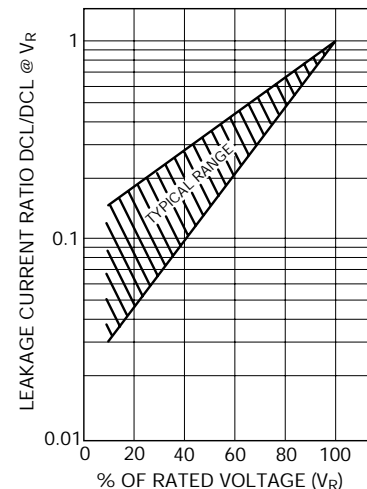

Technical Summary and Application Guidelines

SECTION 2: AC OPERATION — RIPPLE VOLTAGE AND RIPPLE CURRENT

2.1 RIPPLE RATINGS (AC)

In an AC application heat is generated within the capacitor by both the AC component of the signal (which will depend upon signal form, amplitude and frequency), and by the DC leakage. For practical purposes the second factor is insignificant. The actual power dissipated in the capacitor is calculated using the formula:

$$P = I^2 R = \frac{E^2 R}{Z^2}$$

- I = rms ripple current, amperes
- R = equivalent series resistance, ohms
- E = rms ripple voltage, volts
- P = power dissipated, watts
- Z = impedance, ohms, at frequency under consideration

Using this formula it is possible to calculate the maximum AC ripple current and voltage permissible for a particular application.

2.2 MAXIMUM AC RIPPLE VOLTAGE (E_{max})

From the previous equation:

$$E_{(max)} = Z \sqrt{\frac{P_{max}}{R}}$$

where P_{max} is the maximum permissible ripple voltage as listed for the product under consideration (see table).

However, care must be taken to ensure that:

1. The DC working voltage of the capacitor must not be exceeded by the sum of the positive peak of the applied AC voltage and the DC bias voltage.
2. The sum of the applied DC bias voltage and the negative peak of the AC voltage must not allow a voltage reversal in excess of that defined in the sector, 'Reverse Voltage'.

2.3 MAXIMUM PERMISSIBLE POWER DISSIPATION (WATTS) @ 25°C

The maximum power dissipation at 25°C has been calculated for the various series and are shown in Section 2.4, together with temperature derating factors up to 125°C.

For leaded components the values are calculated for parts supported in air by their leads (free space dissipation).

The ripple ratings are set by defining the maximum temperature rise to be allowed under worst case conditions, i.e., with resistive losses at their maximum limit. This differential is normally 10°C at room temperature dropping to 2°C at 125°C. In application circuit layout, thermal management, available ventilation, and signal waveform may significantly

affect the values quoted below. It is recommended that temperature measurements are made on devices during operating conditions to ensure that the temperature differential between the device and the ambient temperature is less than 10°C up to 85°C and less than 2°C between 85°C and 125°C. Derating factors for temperatures above 25°C are also shown below. The maximum permissible proven dissipation should be multiplied by the appropriate derating factor.

For certain applications, e.g., power supply filtering, it may be desirable to obtain a screened level of ESR to enable higher ripple currents to be handled. Please contact our applications desk for information.

2.4 POWER DISSIPATION RATINGS (IN FREE AIR)

TAR – Molded Axial

Case size	Max. power dissipation (W)	Temperature derating factors	
		Temp. °C	Factor
Q	0.065	+25	1.0
R	0.075	+85	0.6
S	0.09	+125	0.4
W	0.105		

TAA – Hermetically Sealed Axial

Case size	Max. power dissipation (W)	Temperature derating factors	
		Temp. °C	Factor
A	0.09	+20	1.0
B	0.10	+85	0.9
C	0.125	+125	0.4
D	0.18		

TAP – Resin Dipped Radial

Case size	Max. power dissipation (W)	Temperature derating factors	
		Temp. °C	Factor
A	0.045	+25	1.0
B	0.05	+85	0.4
C	0.055	+125	0.09
D	0.06		
E	0.065		
F	0.075		
G	0.08		
H	0.085		
J	0.09		
K	0.1		
L	0.11		
M/N	0.12		
P	0.13		
R	0.14		

SECTION 3: RELIABILITY AND CALCULATION OF FAILURE RATE

3.1 STEADY-STATE

Tantalum Dielectric has essentially no wear out mechanism and in certain circumstances is capable of limited self healing, random failures can occur in operation. The failure rate of Tantalum capacitors will decrease with time and not increase as with other electrolytic capacitors and other electronic components.

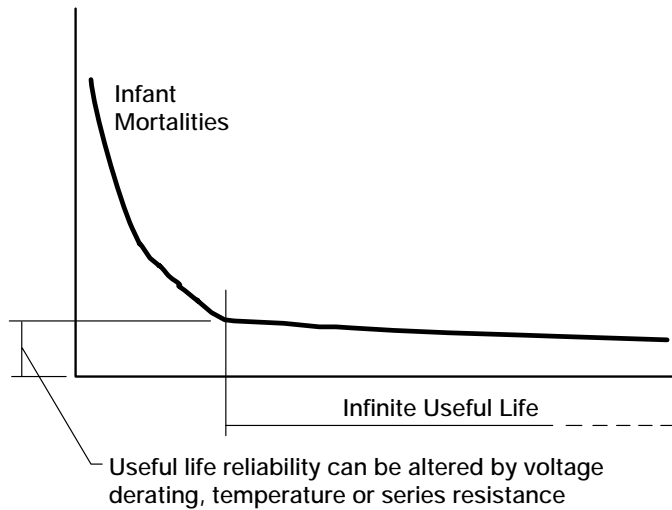

Figure 1. Tantalum reliability curve.

The useful life reliability of the Tantalum capacitor is affected by three factors. The equation from which the failure rate can be calculated is:

$$F = F_U \times F_T \times F_R \times F_B$$

where F_U is a correction factor due to operating voltage/voltage derating

F_T is a correction factor due to operating temperature

F_R is a correction factor due to circuit series resistance

F_B is the basic failure rate level. For standard Tantalum product this is 1%/1000hours

Operating voltage/voltage derating

If a capacitor with a higher voltage rating than the maximum line voltage is used, then the operating reliability will be improved. This is known as voltage derating. The graph, Figure 2, shows the relationship between voltage derating (the ratio between applied and rated voltage) and the failure rate. The graph gives the correction factor F_U for any operating voltage.

Voltage Correction Factor

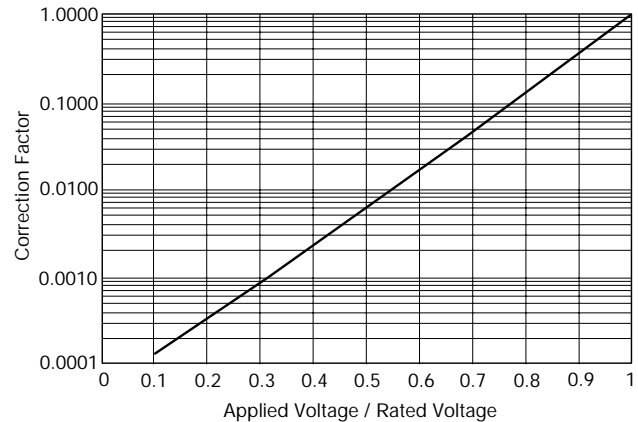

Figure 2. Correction factor to failure rate F for voltage derating of a typical component (60% con. level).

Operating temperature

If the operating temperature is below the rated temperature for the capacitor then the operating reliability will be improved as shown in Figure 3. This graph gives a correction factor F_T for any temperature of operation.

Temperature Correction Factor

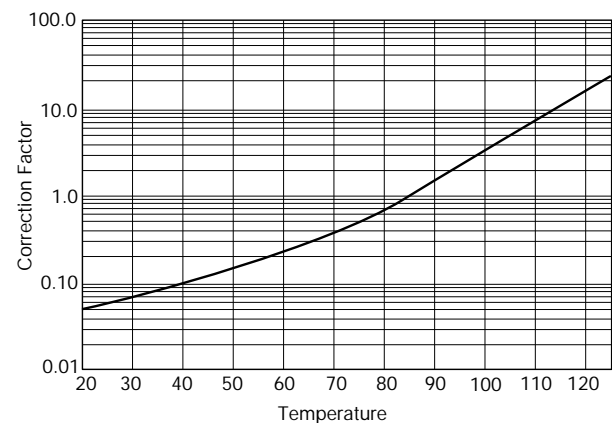

Figure 3. Correction factor to failure rate F for ambient temperature T for typical component (60% con. level).

Technical Summary and Application Guidelines



Circuit Impedance

All solid tantalum capacitors require current limiting resistance to protect the dielectric from surges. A series resistor is recommended for this purpose. A lower circuit impedance may cause an increase in failure rate, especially at temperatures higher than 20°C. An inductive low impedance circuit may apply voltage surges to the capacitor and similarly a non-inductive circuit may apply current surges to the capacitor, causing localized over-heating and failure. The recommended impedance is 1Ω per volt. Where this is not feasible, equivalent voltage derating should be used (See MIL HANDBOOK 217E). Table I shows the correction factor, F_R , for increasing series resistance.

Table I: Circuit Impedance

Correction factor to failure rate F for series resistance R on basic failure rate F_B for a typical component (60% con. level).

Circuit Resistance ohms/volt	FR
3.0	0.07
2.0	0.1
1.0	0.2
0.8	0.3
0.6	0.4
0.4	0.6
0.2	0.8
0.1	1.0

Example calculation

Consider a 12 volt power line. The designer needs about 10μF of capacitance to act as a decoupling capacitor near a video bandwidth amplifier. Thus the circuit impedance will be limited only by the output impedance of the boards power unit and the track resistance. Let us assume it to be about 2 Ohms minimum, i.e., 0.167 Ohms/Volt. The operating temperature range is -25°C to +85°C. If a 10μF 16 Volt capacitor was designed-in, the operating failure rate would be as follows:

- a) $F_T = 0.8 @ 85^\circ\text{C}$
- b) $F_R = 0.7 @ 0.167 \text{ Ohms/Volt}$
- c) $F_U = 0.17 @ \text{applied voltage/rated voltage} = 75\%$

Thus $F_B = 0.8 \times 0.7 \times 0.17 \times 1 = 0.0952\%/1000 \text{ Hours}$

If the capacitor was changed for a 20 volt capacitor, the operating failure rate will change as shown.

$F_U = 0.05 @ \text{applied voltage/rated voltage} = 60\%$
 $F_B = 0.8 \times 0.7 \times 0.05 \times 1 = 0.028\%/1000 \text{ Hours}$

3.2 DYNAMIC

As stated in Section 1.2.4, the solid Tantalum capacitor has a limited ability to withstand voltage and current surges. Such current surges can cause a capacitor to fail. The expected failure rate cannot be calculated by a simple formula as in the case of steady-state reliability. The two parameters under the control of the circuit design engineer known to reduce the incidence of failures are derating and series resistance. The table below summarizes the results of trials carried out at AVX with a piece of equipment which has very low series resistance and applied no derating. So that the capacitor was tested at its rated voltage.

Results of production scale derating experiment

Capacitance and Voltage	Number of units tested	50% derating applied	No derating applied
47μF 16V	1,547,587	0.03%	1.1%
100μF 10V	632,876	0.01%	0.5%
22μF 25V	2,256,258	0.05%	0.3%

As can clearly be seen from the results of this experiment, the more derating applied by the user, the less likely the probability of a surge failure occurring.

It must be remembered that these results were derived from a highly accelerated surge test machine, and failure rates in the low ppm are more likely with the end customer.

Technical Summary and Application Guidelines



A commonly held misconception is that the leakage current of a Tantalum capacitor can predict the number of failures which will be seen on a surge screen. This can be disproved by the results of an experiment carried out at AVX on 47µF 10V surface mount capacitors with different leakage currents. The results are summarized in the table below.

Leakage Current vs Number of Surge Failures

	Number tested	Number failed surge
Standard leakage range 0.1 µA to 1µA	10,000	25
Over Catalog limit 5µA to 50µA	10,000	26
Classified Short Circuit 50µA to 500µA	10,000	25

Again, it must be remembered that these results were derived from a highly accelerated surge test machine, and failure rates in the low ppm are more likely with the end customer.

AVX recommended derating table

Voltage Rail	Working Cap Voltage
3.3	6.3
5	10
10	20
12	25
15	35
≥24	Series Combinations (11)

For further details on surge in Tantalum capacitors refer to J.A. Gill's paper "Surge in Solid Tantalum Capacitors", available from AVX offices worldwide.

An added bonus of increasing the derating applied in a circuit, to improve the ability of the capacitor to withstand surge conditions, is that the steady-state reliability is improved by up to an order. Consider the example of a 6.3 volt capacitor being used on a 5 volt rail. The steady-state reliability of a Tantalum capacitor is affected by three parameters; temperature, series resistance and voltage derating. Assuming 40°C operation and 0.1Ω/volt of series resistance, the scaling factors for temperature and series resistance will both be 0.05 [see Section 3.1]. The derating factor will be 0.15. The capacitors reliability will therefore be

$$\begin{aligned} \text{Failure rate} &= F_U \times F_T \times F_R \times 1\%/1000 \text{ hours} \\ &= 0.15 \times 0.05 \times 1 \times 1\%/1000 \text{ hours} \\ &= 7.5\% \times 10^{-3}/\text{hours} \end{aligned}$$

If a 10 volt capacitor was used instead, the new scaling factor would be 0.017, thus the steady-state reliability would be

$$\begin{aligned} \text{Failure rate} &= F_U \times F_T \times F_R \times 1\%/1000 \text{ hours} \\ &= 0.017 \times 0.05 \times 1 \times 1\%/1000 \text{ hours} \\ &= 8.5\% \times 10^{-4}/1000 \text{ hours} \end{aligned}$$

So there is an order improvement in the capacitors steady-state reliability.

3.3 RELIABILITY TESTING

AVX performs extensive life testing on tantalum capacitors.

- 2,000 hour tests as part of our regular Quality Assurance Program.

Test conditions:

- 85°C/rated voltage/circuit impedance of 3Ω max.
- 125°C/0.67 x rated voltage/circuit impedance of 3Ω max.

3.4 Mode of Failure

This is normally an increase in leakage current which ultimately becomes a short circuit.



Technical Summary and Application Guidelines



SECTION 4: APPLICATION GUIDELINES FOR TANTALUM CAPACITORS

4.1 SOLDERING CONDITIONS AND BOARD ATTACHMENT

The soldering temperature and time should be the minimum for a good connection.

A suitable combination for wavesoldering is 230 - 250°C for 3 - 5 seconds.

Small parametric shifts may be noted immediately after wave solder, components should be allowed to stabilize at room temperature prior to electrical testing.

AVX leaded tantalum capacitors are designed for wave soldering operations.

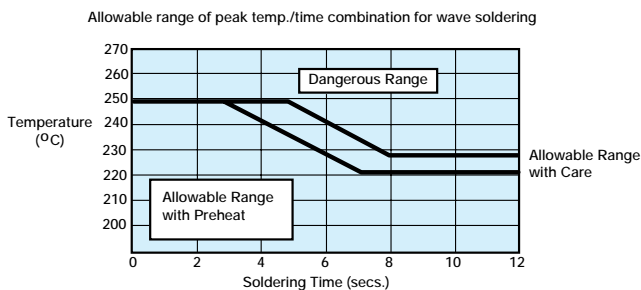

4.2 RECOMMENDED SOLDERING PROFILES

Recommended wave soldering profile for mounting of tantalum capacitors except MINITANS* is shown below.

After soldering the assembly should preferably be allowed to cool naturally. In the event that assisted cooling is used, the rate of change in temperature should not exceed that used in reflow.

*Note: TMH and TMM Series are not recommended for wave soldering.

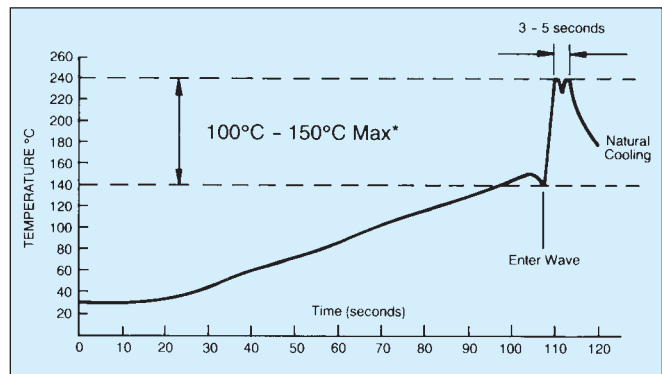

*See appropriate product specification

SECTION 5: MECHANICAL AND THERMAL PROPERTIES, LEADED CAPACITORS

5.1 ACCELERATION

10 g (981 m/s)

5.2 VIBRATION SEVERITY

10 to 2000 Hz, 0.75 mm or 98 m/s²

5.3 SHOCK

Trapezoidal Pulse 10 g (981 m/s) for 6 ms

5.4 TENSILE STRENGTH OF CONNECTION

10 N for type TAR, 5 N for type TAP. (See MINITAN Section for limits.)

5.5 BENDING STRENGTH OF CONNECTIONS

2 bends at 90°C with 50% of the tensile strength test loading. (See Minitan Section for limits.)

5.6 SOLDERING CONDITIONS

Dip soldering permissible provided solder bath temperature $\leq 270^\circ\text{C}$; solder time < 3 sec.; circuit board thickness ≥ 1.0 mm.

5.7 INSTALLATION INSTRUCTIONS

The upper temperature limit (maximum capacitor surface temperature) must not be exceeded even under the most unfavorable conditions when the capacitor is installed. This must be considered particularly when it is positioned near components which radiate heat strongly (e.g., valves and power transistors). Furthermore, care must be taken, when bending the wires, that the bending forces do not strain the capacitor housing.

5.8 INSTALLATION POSITION

No restriction.

5.9 SOLDERING INSTRUCTIONS

Fluxes containing acids must not be used.



Technical Summary and Application Guidelines

QUESTIONS AND ANSWERS

Some commonly asked questions regarding Tantalum Capacitors:

Question: If I use several tantalum capacitors in serial/parallel combinations, how can I ensure equal current and voltage sharing?

Answer: Connecting two or more capacitors in series and parallel combinations allows almost any value and rating to be constructed for use in an application. For example, a capacitance of more than 60µF is required in a circuit for stable operation. The working voltage rail is 24 Volts dc with a superimposed ripple of 1.5 Volts at 120 Hz.

The maximum voltage seen by the capacitor is $V_{dc} + V_{ac} = 25.5V$

Applying the 50% derate rule tells us that a 50V capacitor is required.

Connecting two 25V rated capacitors in series will give the required capacitance voltage rating, but the effective capacitance will be halved, so for greater than

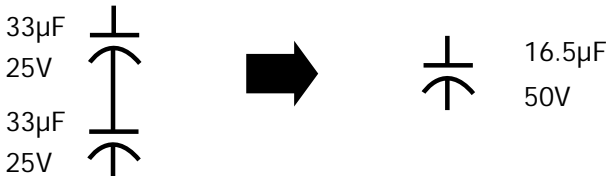

60µF, four such series combinations are required, as shown.

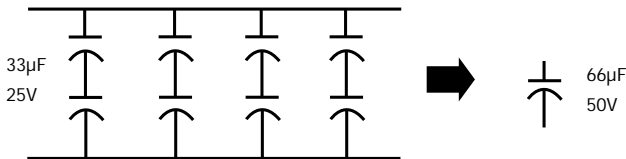

In order to ensure reliable operation, the capacitors should be connected as shown below to allow current sharing of the ac noise and ripple signals. This prevents any one capacitor heating more than its neighbors and thus being the weak link in the chain.

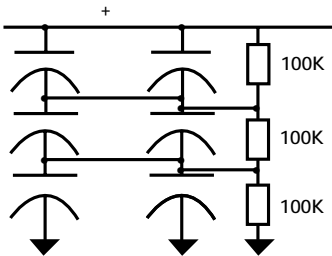

The two resistors are used to ensure that the leakage currents of the capacitors does not affect the circuit reliability, by ensuring that all the capacitors have half the working voltage across them.

Question: What are the advantages of tantalum over other capacitor technologies?

Answer:

1. Tantalums have high volumetric efficiency.
2. Electrical performance over temperature is very stable.
3. They have a wide operating temperature range -55 degrees C to +125 degrees C.
4. They have better frequency characteristics than aluminum electrolytics.
5. No wear out mechanism. Because of their construction, solid tantalum capacitors do not degrade in performance or reliability over time.

Question: If the part is rated as a 25 volt part and you have current surged it, why can't I use it at 25 volts in a low impedance circuit?

Answer: The high volumetric efficiency obtained using tantalum technology is accomplished by using an extremely thin film of tantalum pentoxide as the dielectric. Even an application of the relatively low voltage of 25 volts will produce a large field strength as seen by the dielectric. As a result of this, derating has a significant impact on reliability as described under the reliability section. The following example uses a 22 microfarad capacitor rated at 25 volts to illustrate the point. The equation for determining the amount of surface area for a capacitor is as follows:

$$C = (\epsilon (E_0) (A)) / d$$

$$A = (C (d)) / (\epsilon_0 \epsilon)$$

$$A = ((22 \times 10^{-6}) (170 \times 10^{-9})) / ((8.85 \times 10^{-12}) (27))$$

$$A = 0.015 \text{ square meters (150 square centimeters)}$$

Where C = Capacitance in farads

A = Dielectric (Electrode) Surface Area (m²)
 d = Dielectric thickness (Space between dielectric) (m)

E = Dielectric constant (27 for tantalum)
 E° = Dielectric Constant relative to a vacuum
 (8.855 x 10⁻¹² Farads x m⁻¹)

To compute the field voltage potential felt by the dielectric we use the following logic.

$$\text{Dielectric formation potential} = \text{Formation Ratio} \times \text{Working Voltage}$$

$$= 4 \times 25$$

$$\text{Formation Potential} = 100 \text{ volts}$$

Dielectric (Ta₂O₅) Thickness (d) is 1.7 x 10⁻⁹ Meters Per Volt
 d = 0.17 µ meters

$$\text{Electric Field Strength} = \text{Working Voltage} / d$$

$$= (25 / 0.17 \mu \text{ meters})$$

$$= 147 \text{ Kilovolts per millimeter}$$

$$= 147 \text{ Megavolts per meter}$$

Technical Summary and Application Guidelines



QUESTIONS AND ANSWERS

No matter how pure the raw tantalum powder or the precision of processing, there will always be impurity sites in the dielectric. We attempt to stress these sites in the factory with overvoltage surges, and elevated temperature burn in so that components will fail in the factory and not in your product. Unfortunately, within this large area of tantalum pentoxide, impurity sites will exist in all capacitors. To minimize the possibility of providing enough activation energy for these impurity sites to turn from an amorphous state to a crystalline state that will conduct energy, series resistance and derating is recommended. By reducing the electric field within the anode at these sites, the tantalum capacitor has increased reliability. Tantalums differ from other electrolytics in that charge transients are carried by electronic conduction rather than absorption of ions.

Question: What negative transients can Solid Tantalum Capacitors operate under?

Answer: The reverse voltage ratings are designed to cover exceptional conditions of small level excursions into incorrect polarity. The values quoted are not intended to cover continuous reverse operation. The peak reverse voltage applied to the capacitor must not exceed:

- 10% of rated DC working voltage to a maximum of 1 volt at 25 degrees C.

- 3% of rated DC working voltage to a maximum of 0.5 volt at 85 degrees C.

- 1% of category DC working voltage to a maximum of 0.1 volt at 125 C.

Question: I have read that manufacturers recommend a series resistance of 0.1 ohm per working volt. You suggest we use 1 ohm per volt in a low impedance circuit. Why?

Answer: We are talking about two very different sets of circuit conditions for those recommendations. The 0.1 ohm per volt recommendation is for steady-state conditions. This level of resistance is used as a basis for the series resistance variable in a 1% / 1000 hours 60% confidence level reference. This is what steady-state life tests are based on. The 1 ohm per volt is recommended for dynamic conditions which include current in-rush applications such as inputs to power supply circuits. In many power supply topologies where the di / dt through the capacitor(s) is limited, (such as most implementations of buck (current mode), forward converter, and flyback), the requirement for series resistance is decreased.

Question: How long is the shelf life for a tantalum capacitor?

Answer: Solid tantalum capacitors have no limitation on shelf life. The dielectric is stable and no reformation is required. The only factors that affect future performance of the capacitors would be high humidity conditions and extreme storage temperatures. Solderability of solder coated surfaces may be affected by storage in excess of one year under temperatures greater than 40 degrees C or humidities greater than 80% relative humidity. Terminations should be checked for solderability in the event an oxidation develops on the solder plating.

1. Steve Warden and John Gill, "Application Guidelines on IR Reflow of Surface Mount Solid Tantalum Capacitors."
2. John Gill, "Glossary of Terms used in the Tantalum Industry."
3. R.W. Franklin, "Over-Heating in Failed Tantalum Capacitors," AVX Ltd.
4. R.W. Franklin, "Upgraded Surge Performance of Tantalum Capacitors," Electronic Engineering 1985
5. R.W. Franklin, "Screening beats surge threat," Electronics Manufacture & Test, June 1985
6. AVX Surface Mounting Guide
7. Ian Salisbury, "Thermal Management of Surface Mounted Tantalum Capacitors," AVX
8. John Gill, "Investigation into the Effects of Connecting Tantalum Capacitors in Series," AVX
9. Ian Salisbury, "Analysis of Fusing Technology for Tantalum Capacitors," AVX-Kyocera Group Company
10. R.W. Franklin, "Analysis of Solid Tantalum Capacitor Leakage Current," AVX Ltd.
11. R.W. Franklin, "An Exploration of Leakage Current," AVX, Ltd.
12. William A. Millman, "Application Specific SMD Tantalum Capacitors," Technical Operations, AVX Ltd.
13. R.W. Franklin, "Capacitance Tolerances for Solid Tantalum Capacitors," AVX Ltd.
14. Arch G. Martin, "Decoupling Basics," AVX Corporation
15. R.W. Franklin, "Equivalent Series Resistance of Tantalum Capacitors," AVX Ltd.
16. John Stroud, "Molded Surface Mount Tantalum Capacitors vs Conformally Coated Capacitors," AVX Corporation, Tantalum Division
17. Chris Reynolds, "Reliability Management of Tantalum Capacitors," AVX Tantalum Corporation
18. R.W. Franklin, "Ripple Rating of Tantalum Chip Capacitors," AVX Ltd.
19. Chris Reynolds, "Setting Standard Sizes for Tantalum Chips," AVX Corporation
20. John Gill, "Surge In Solid Tantalum Capacitors," AVX Ltd.
21. David Mattingly, "Increasing Reliability of SMD Tantalum Capacitors in Low Impedance Applications," AVX Corporation
22. John Gill, "Basic Tantalum Technology," AVX Ltd.
23. Ian Salisbury, "Solder Update Reflow Mounting TACmicrochip Tantalum Capacitor," AVX Ltd.
24. Ian Salisbury, "New Tantalum Capacitor Design for 0603 Size," AVX Ltd.
25. John Gill, "Capacitor Technology Comparison," AVX Ltd.
26. Scott Chiang, "High Performance CPU Capacitor Requirements, how AVX can help," AVX Kyocera Taiwan
27. John Gill and Ian Bishop, "Reverse Voltage Behavior of Solid Tantalum Capacitors."

NOTICE: Specifications are subject to change without notice. Contact your nearest AVX Sales Office for the latest specifications. All statements, information and data given herein are believed to be accurate and reliable, but are presented without guarantee, warranty, or responsibility of any kind, expressed or implied. Statements or suggestions concerning possible use of our products are made without representation or warranty that any such use is free of patent infringement and are not recommendations to infringe any patent. The user should not assume that all safety measures are indicated or that other measures may not be required. Specifications are typical and may not apply to all applications.

USA

AVX Myrtle Beach, SC Corporate Offices

Tel: 843-448-9411
FAX: 843-448-1943

AVX Northwest, WA

Tel: 360-669-8746
FAX: 360-699-8751

AVX North Central, IN

Tel: 317-848-7153
FAX: 317-844-9314

AVX Northeast, MA

Tel: 508-485-8114
FAX: 508-485-8471

AVX Mid-Pacific, CA

Tel: 408-436-5400
FAX: 408-437-1500

AVX Southwest, AZ

Tel: 602-539-1496
FAX: 602-539-1501

AVX South Central, TX

Tel: 972-669-1223
FAX: 972-669-2090

AVX Southeast, NC

Tel: 919-878-6357
FAX: 919-878-6462

AVX Canada

Tel: 905-564-8959
FAX: 905-564-9728

EUROPE

AVX Limited, England European Headquarters

Tel: ++44 (0)1252 770000
FAX: ++44 (0)1252 770001

AVX S.A., France

Tel: ++33 (1) 69.18.46.00
FAX: ++33 (1) 69.28.73.87

AVX GmbH, Germany - AVX

Tel: ++49 (0) 8131 9004-0
FAX: ++49 (0) 8131 9004-44

AVX GmbH, Germany - Elco

Tel: ++49 (0) 2741 2990
FAX: ++49 (0) 2741 299133

AVX srl, Italy

Tel: ++390 (0)2 614571
FAX: ++390 (0)2 614 2576

AVX sro, Czech Republic

Tel: ++420 (0)467 558340
FAX: ++420 (0)467 558345

ASIA-PACIFIC

AVX/Kyocera, Singapore Asia-Pacific Headquarters

Tel: (65) 258-2833
FAX: (65) 350-4880

AVX/Kyocera, Hong Kong

Tel: (852) 2-363-3303
FAX: (852) 2-765-8185

AVX/Kyocera, Korea

Tel: (82) 2-785-6504
FAX: (82) 2-784-5411

AVX/Kyocera, Taiwan

Tel: (886) 2-2516-7010
FAX: (886) 2-2506-9774

AVX/Kyocera, China

Tel: (86) 21-6249-0314-16
FAX: (86) 21-6249-0313

AVX/Kyocera, Malaysia

Tel: (60) 4-228-1190
FAX: (60) 4-228-1196

Elco, Japan

Tel: 045-943-2906/7
FAX: 045-943-2910

Kyocera, Japan - AVX

Tel: (81) 75-604-3426
FAX: (81) 75-604-3425

Kyocera, Japan - KDP

Tel: (81) 75-604-3424
FAX: (81) 75-604-3425

Contact:



<http://www.avxcorp.com>

S-TLG13M599-C