

# TA-F22ESX / F500ES

## SERVICE MANUAL



Photo: TA-F500ES

*E Model*  
 TA-F500ES:  
*G-AEP Model*  
*AEP Model*  
*UK Model*  
*US Model*  
*Canadian Model*

### SPECIFICATIONS

#### POWER OUTPUT AND TOTAL HARMONIC DISTORSION (US Model):

With 4 ohm loads, both channels driven, from 20 - 20,000 Hz; rated 100 watts per channel minimum RMS power, with no more than 0.01% total harmonic distortion from 250 milliwatts to rated output.  
 With 8 ohm loads, both channels driven, from 20 - 20,000 Hz; rated 80 watts per channel minimum RMS power, with no more than 0.006% total harmonic distortion from 250 milliwatts to rated output.

#### SAFETY-RELATED COMPONENT WARNING!!

COMPONENTS IDENTIFIED BY SHADING AND MARK  ON THE SCHEMATIC DIAGRAMS AND IN THE PARTS LIST ARE CRITICAL TO SAFE OPERATION. REPLACE THESE COMPONENTS WITH SONY PARTS WHOSE PART NUMBERS APPEAR AS SHOWN IN THIS MANUAL OR IN SUPPLEMENTS PUBLISHED BY SONY

ATTENTION AU COMPOSANT AYANT RAPPORT À LA SÉCURITÉ!

LES COMPOSANTS IDENTIFIÉS PAR UNE TRAME ET UNE MARQUE  SUR LES DIAGRAMMES SCHEMATIQUES ET LA LISTE DES PIÈCES SONT CRITIQUES POUR LA SÉCURITÉ DE FONCTIONNEMENT. NE REMPLACER CES COMPOSANTS QUE PAR DES PIÈCES SONY DONT LES NUMÉROS SONT DONNÉS DANS CE MANUEL OU DANS LES SUPPLÉMENTS PUBLIÉS PAR SONY.

Item	Condition	Data
Continuous RMS power output (both channels driven simultaneously)	4 ohms 20 Hz - 20 kHz THD 0.01%	100 W + 100 W (USA, Canada and North European countries)
		120 W + 120 W (other countries)
	6 ohms 20 - 20 kHz THD 0.008%	90 W + 90 W (USA, Canada and North European countries)
		100 W + 100 W (other countries)
	8 ohms 20 - 20 kHz THD 0.006%	80 W + 80 W (USA, Canada and North European countries)
		90 W + 90 W (other countries)
Power band-width (IHF)	4 ohms, 0.02%	10 Hz - 100 kHz
	8 ohms, THD 0.02%	10 Hz - 100 kHz
Dynamic headroom ('78 IHF)	4 ohms	2 dB
	8 ohms	1.2 dB

- Continued on page 2 -



# INTEGRATED STEREO AMPLIFIER

# SONY®

# TA-F222ESX/F500ES

Total harmonic distortion	4 ohms, at 10 watt output	0.006%	
	6 ohms, at 10 watt output	0.004%	
	8 ohms, at 10 watt output	0.003%	
Intermodulation (IM) distortion 60 Hz: 7 kHz = 4:1	4 ohms at rated output	0.009%	
	6 ohms at rated output	0.008%	
	8 ohms at rated output	0.006%	
Damping factor	8 ohms, 1 kHz	50	
Slew rate	—	125 V/ $\mu$ sec 250 V/ $\mu$ sec (inside)	
Residual noise	network A	less than 90 $\mu$ V	
Frequency response	PHONO MM	RIAA equalization curve $\pm 0.2$ dB	
	TUNER, CD, TAPE, VIDEO 1,2	2 Hz - 200 kHz $+0$ $-3$ dB	
Input sensitivity	PHONO	MC	0.17 mV, 1 kohm
		MM	2.5 mV, 50 kohms
	TUNER, CD, AUX, TAPE, AUDIO IN, ADAPTOR IN		150 mV, 50 kohms
Maximum input capability (1 kHz)	PHONO (1 kHz, THD 0.003%)	MC	9 mV
		MM	150 mV
S/N (network)	PHONO	MC	76 dB*, 68 dB (A)
		MM	80 dB*, 86 dB (A)
* 78 IHF	TUNER, CD, AUX, TAPE, AUDIO IN, ADAPTOR IN	84 dB*, 105 dB (A)	
Output voltage impedance	REC OUT, AUDIO OUT, ADAPTOR OUT	150 mV, 1 kohm	
	HEADPHONES	25 milliwatts (at 8 ohms) Accepts low and high impedance headphones.	
Tone controls	BASS, at 100 Hz	$\pm 6$ dB (turnover freq. 400 Hz)	
	TREBLE, at 10 kHz	$\pm 6$ dB (turnover freq. 3 kHz)	
SUBSONIC filter	—	6 dB/octave attenuation below 15 Hz	

## General

### System

Preamplifier section: Low-noise FET high gain NFB type equalizer amplifier, passive type direct tone control  
Power amplifier section: purecomplementary SEPP power amplifier

### Power requirements

US, Canadian model: 120 V AC, 60 Hz  
UK model: 240 V AC, 50 Hz  
G-AEP, AEP model: 220 V AC, 50/60 Hz  
E model: 120, 220, or 240 V AC adjustable, 50/60 Hz

### Power consumption

US model: 210 watts  
Canadian model: 410 VA  
UK model: 220 watts  
G-AEP, AEP model: 250 watts  
E model: 205 watts

### AC outlets

US, Canadian model:  
2 switched, total 100 watts max.  
2 unswitched, total 100 watts max.

G-AEP, AEP model:  
1 switched, 100 watts max.

UK, E model:  
1 switched, 100 watts max.  
1 unswitched, 100 watts max.

### Dimensions

Approx. 430 x 148 x 373 mm (w/h/d)  
(17 x 5 $\frac{3}{4}$  x 14 $\frac{3}{4}$  inches)

including projecting parts and controls

### Weight

Approx. 13.2 kg (29 lbs 1 oz) net

## MODEL IDENTIFICATION

— Specification Label —

TA-F222ESX, TA-F500ES

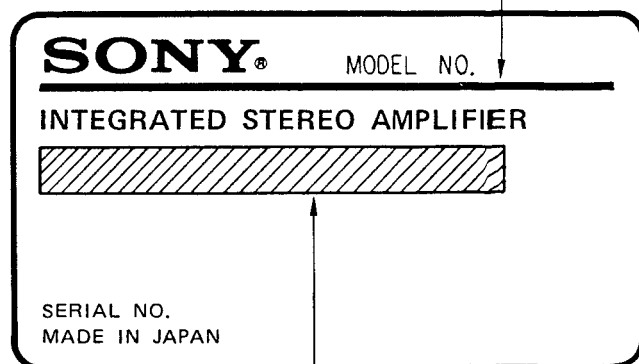

G-AEP, AEP Model: AC: 220 V ~ 50/60 Hz 280 W

UK Model: AC: 240 V ~ 50/60 Hz 185 W

E Model: AC: 120/220/240 V ~ 50/60 Hz 205 W

US Model: AC: 120 V 60 Hz 170 W

Canadian Model: AC: 120 V 60 Hz 340 VA

## FEATURES

Newly developed technologies assure excellent performance and tone quality

### Pure sound

A head chassis, named "Gibraltar" which provides high rigidity and periodic damping characteristics, is employed to reduce distortion caused by vibrations. This reduces air vibrations caused by floor and speakers and also reduces vibrations caused by the power transformer and power transistors.

### Spontaneous twin drive power circuit

Condensers having large capacity are used for the voltage amplification drive stage of class A and power output stage of class B. Thus, a stable output and high quality sound are obtained, resulting in exclusion of power interferences. The class A stage realizes a stable operation free from interference of the power stage even when an instantaneous or strong output is received.

### Simple and direct tone control

The tone controls consist of only passive elements to minimize the deterioration of tone quality at the tone control circuit. Tone control elements can be passed by depressing the tone switch.

### Source direct switch

A source direct switch is employed to reproduce high fidelity sound. Any source can be reproduced without passing through the circuits of tone control, subsonic filter, mode switch and balance control.

### Super legato linear system

The power amplifier drives low impedance speakers and assures powerful reproduction without low crossover distortion and switching distortion over the wide range.

## TABLE OF CONTENTS

<u>Section</u>	<u>Title</u>	<u>Page</u>
	Specifications . . . . .	1
	Model Identification . . . . .	2
	Features . . . . .	3
	Safety Check-out (US Model) . . . . .	3
	Function of Controls . . . . .	4
	Operating Voltage . . . . .	6
<b>1.</b>	<b>ELECTRICAL ADJUSTMENT . . . . .</b>	<b>6</b>
<b>2.</b>	<b>DIAGRAMS</b>	
2-1.	Power Supply Section	
	Mounting Diagram . . . . .	7
2-2.	Mounting Diagram . . . . .	10
2-3.	Schematic Diagram . . . . .	15
<b>3.</b>	<b>EXPLODED VIEWS AND PARTS LIST . . . . .</b>	<b>21</b>
<b>4.</b>	<b>ELECTRICAL PARTS LIST . . . . .</b>	<b>24</b>
	Trouble Checks . . . . .	29

## SAFETY CHECK-OUT (US Model)

After correcting the original service problem, perform the following safety check before releasing the set to the customer:

Check the antenna terminals, metal trim, "metallized" knobs, screws, and all other exposed metal parts for AC leakage. Check leakage as described below.

### LEAKAGE TEST

The AC leakage from any exposed metal part to earth ground and from all exposed metal parts to any exposed metal part having a return to chassis, must not exceed 0.5 mA (500 microamperes). Leakage current can be measured by any one of three methods.

1. A commercial leakage tester, such as the Simpson 229 or RCA WT-540A. Follow the manufacturers' instructions to use these instruments.
2. A battery-operated AC milliammeter. The Data Precision 245 digital multimeter is suitable for this job.
3. Measuring the voltage drop across a resistor by means of a VOM or battery-operated AC voltmeter. The "limit" indication is 0.75 V, so analog meters must have an accurate low-voltage scale. The Simpson 250 and Sanwa SH-63Trd are examples of a passive VOM that is suitable. Nearly all battery operated digital multimeters that have a 2 V AC range are suitable. (See Fig. A)

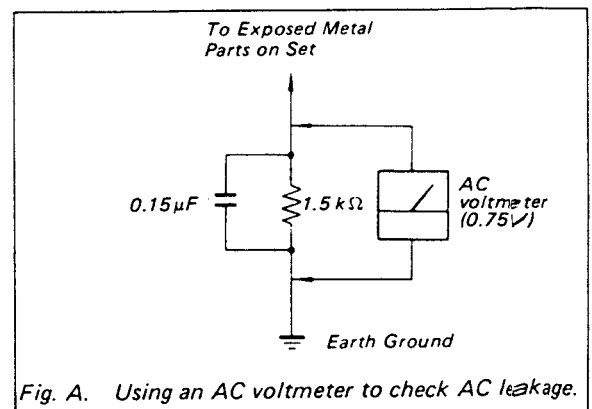

Fig. A. Using an AC voltmeter to check AC leakage.

# TA-F22ESX/F500ES

## FUNCTION OF CONTROLS

### Front panel

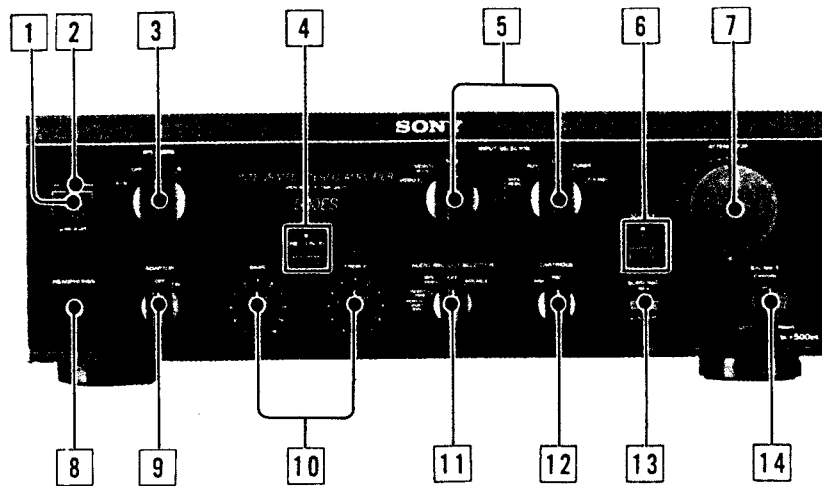

Photo: TA-F500ES

**1 POWER switch**

**2 Power/standby indicator**

Immediately after turning ON the power, the standby indicator lights in red as the built-in muting circuit activates. When the amplifier stays in a stable operating condition, the indicator lights in green. The indicator lights in red when the unit detects shorting of circuit of the speaker outputs or in case of short-circuit of the inputs of DC components. In such a case, disconnect the power source and check the connected components and speaker systems.

**3 SPEAKERS selector**

Select speaker system A or B, or both. For headphone monitoring only, set the selector to OFF.

**4 TONE switch and indicator**

Depress the switch to activate the tone control circuit. Red indicator lights.

**5 INPUT SELECTOR and tape/video selector**

To select the desired program source, use the INPUT SELECTOR. To select TAPE, VIDEO 1 or 2, set the INPUT SELECTOR to TAPE/VIDEO and set the tape/video selector to the desired input position.

**6 SOURCE DIRECT switch and indicator**

Depress the switch. The indicator lights and the circuits of the TONE or SUBSONIC switches and BALANCE control are disengaged without regard to the setting of the switches. When this switch is activated, the indicator of the TONE switch does not light.

**7 ATTENUATOR knob**

Regulates the sound level.

**8 HEADPHONES jack (stereo phone jack)**

**9 ADAPTOR switch**

When an additional equipment, such as a graphic equalizer, surround processor, etc. is connected to ADAPTOR IN/OUT jacks (on rear panel), set to ON position. When the jacks are not used, set to OFF position.

**10 BASS and TREBLE controls**

These controls activate when the TONE switch is depressed.

**11 AUDIO REC OUT SELECTOR**

Selects the program source sent to the REC OUT and AUDIO OUT jacks (rear panel).

**12 CARTRIDGE LOAD selector**

Set the selector according to your cartridge. MM: For moving-magnet type cartridge MC: For moving-coil type cartridge

**13 SUBSONIC filter switch**

Depress the switch to reduce unwanted noise components of less than 15 Hz, which cause modulation noise.

**14 BALANCE control**

Controls the sound level of left and right speakers.

Rear panel

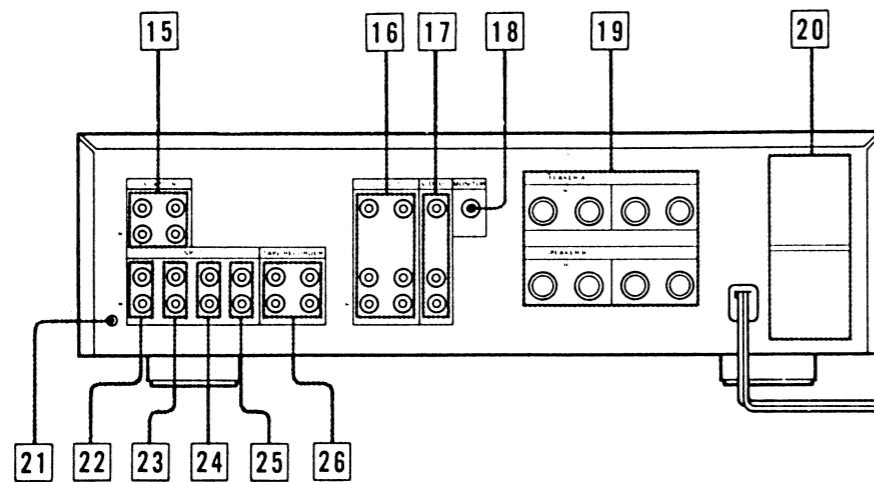

**15 ADAPTOR IN/OUT (input and output) jacks**

The OUT jacks output the signals selected by the INPUT SELECTOR on the front panel and the IN jacks receive the signals.

**16 VIDEO 1 input/output jacks**

OUT (video output) jack: Connect to the video input jack of a video cassette recorder.  
 IN (video input) jack: Accept the video output of a video cassette recorder.  
 AUDIO OUT (audio output) jacks: Connect to the audio input jacks of a video cassette recorder.  
 AUDIO IN (audio input) jacks: Accept the audio output of a video cassette recorder.

**17 VIDEO 2 input jacks**

IN (video input) jacks: Accept the video output of a video disc player.  
 AUDIO IN (audio input) jacks: Accept the audio output of a video disc player.

**18 MONITOR VIDEO OUT (video output) jack**

Outputs the video signal selected by the INPUT SELECTOR and tape/video selector.

**19 SPEAKER output terminals**

Two pairs of speaker systems can be connected. System A, system B or system A and B can be selected by means of the front panel SPEAKERS selector.

**20 AC OUTLET(s)**

The AC OUTLET is used to power other audio components whose total power consumption is less than the wattage indicated near the AC OUTLET.

**21 Ground terminal**

To prevent hum, be sure to connect the ground wire of the turntable system to this ground terminal. If hum still exists, it may be helpful to connect the ground terminal directly to earth via a ground rod.

**Note**

In some particular MM cartridges, the ground for signal is connected to the ground for cartridge body. If this type of cartridge should be installed to a metal cartridge shell, current will flow through the tonearm ground in a loop and will cause hum noise. In this case, disconnect the turntable ground wire from the ground terminal of the amplifier, or disconnect the ground for cartridge body from the ground for signal.

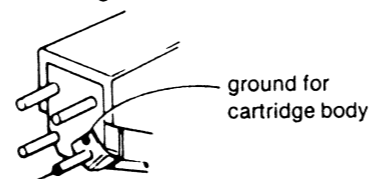

**22 PHONO input jacks**

**23 TUNER input jacks**

**24 CD (Compact Disc) input jacks**

**25 AUX (Auxiliary) input jacks**

**26 TAPE RECORDER input/output jacks**

REC OUT (recording output) jacks: Output the audio signal selected by the AUDIO REC OUT SELECTOR.  
 TAPE (tape input) jacks: Accept the line output of the tape recorder.

OPERATING VOLTAGE

Before connecting the unit to an AC outlet, be sure that the operating voltage of your unit is identical with that of your local power supply.

TA-F500ES	USA and Canada	Operates on 120 V AC, 60Hz
	European countries	Operates on 220 V AC (or 240 V adjustable by authorized Sony personnel), 50/60 Hz.
	United Kingdom	Operates on 240 V AC (or 220 V AC adjustable by authorized Sony personnel), 50 Hz.
TA-F222ESX	other countries	Operates on either 120 V, 220 V or 240 V AC, 50/60 Hz. The voltage selector is located on the rear panel. If the selector must be reset, disconnect the AC power cord and turn the selector with a coin so that the arrow mark of the selector points to the proper voltage figure.

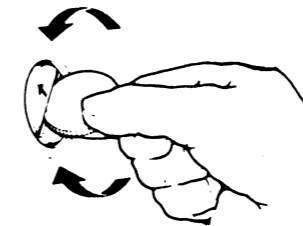

Idling Current Adjustment

Setting:

Volume: minimum  
 Input signal: no signal

Procedure:

Adjust RT402 (L-CH) and RT452 (R-CH) so as to obtain 5 mV at TP401 (L-CH) and TP451 (R-CH) respectively.

Adjustment Location: main board

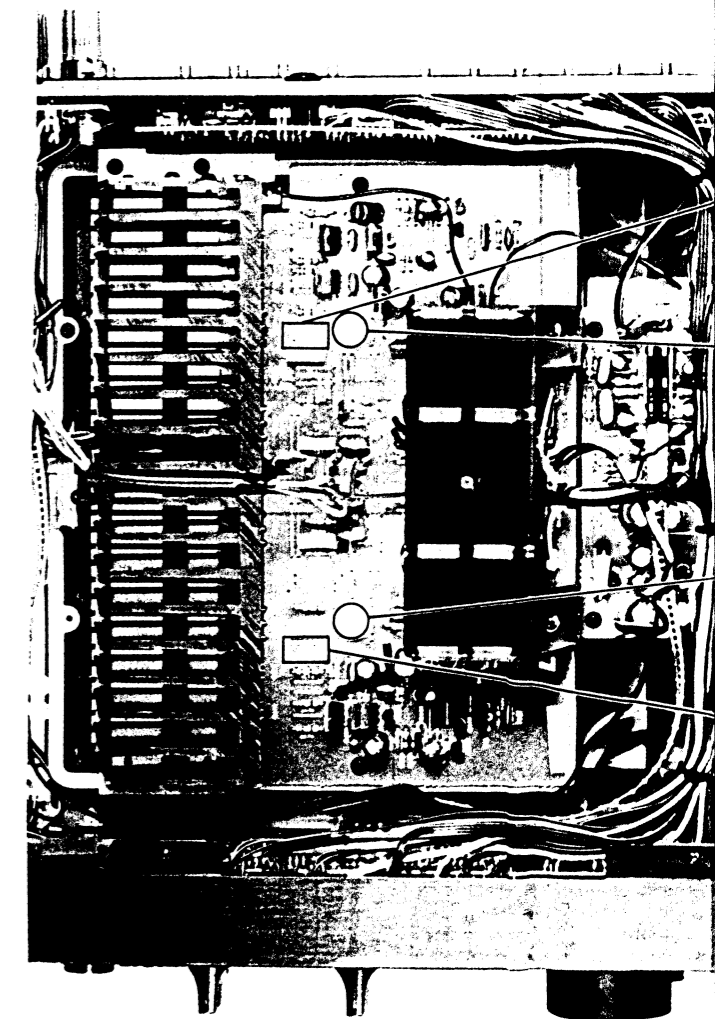

SECTION 1  
ELECTRICAL ADJUSTMENTS

Idling Current Adjustment

Setting:

Volume: minimum  
Input signal: no signal

Procedure:

Adjust RT402 (L-CH) and RT452 (R-CH) so as to obtain 5 mV at TP401 (L-CH) and TP451 (R-CH) respectively.

Adjustment Location: main board

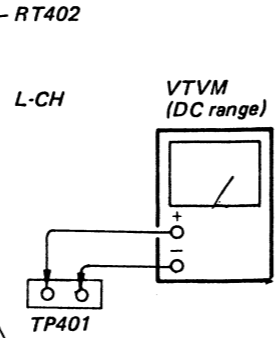
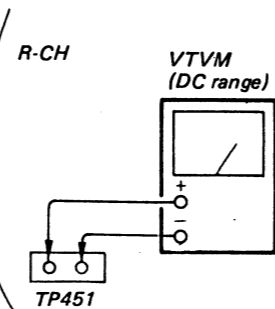
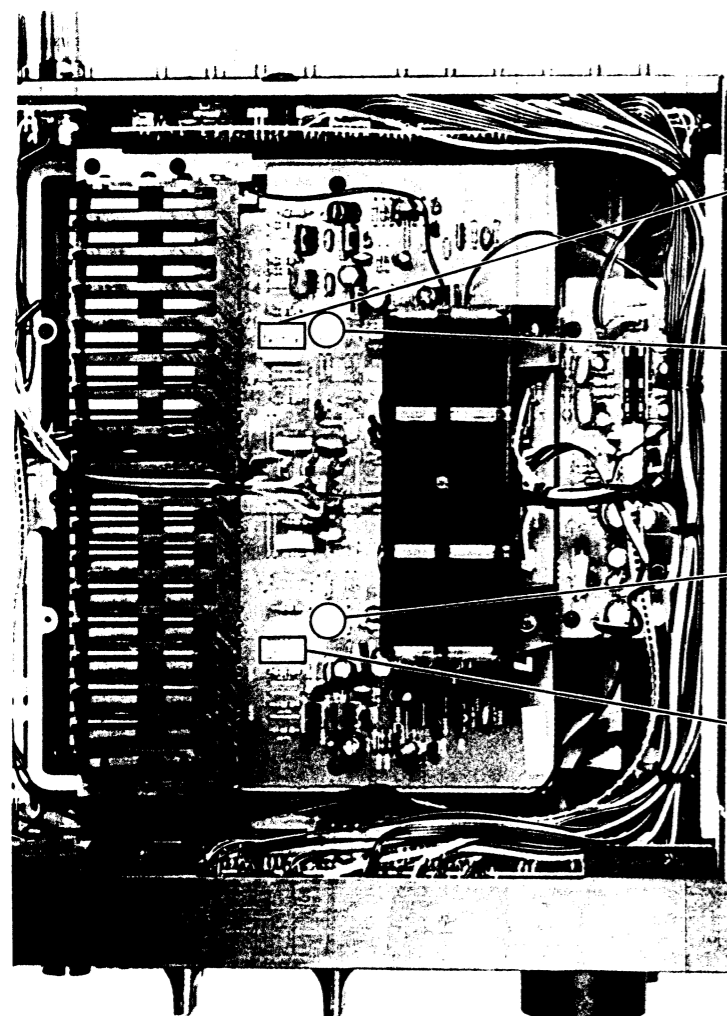

SECTION 2  
DIAGRAMS

2-1. POWER SUPPLY SECTION MOUNTING DIAGRAM - G-AEP, AEP, UK, E Model -

- See page 10 for Semiconductor Lead Layouts.
- See page 14 for US, Canadian model Power Supply Section.
- See page 19 for Circuit Boards Location.

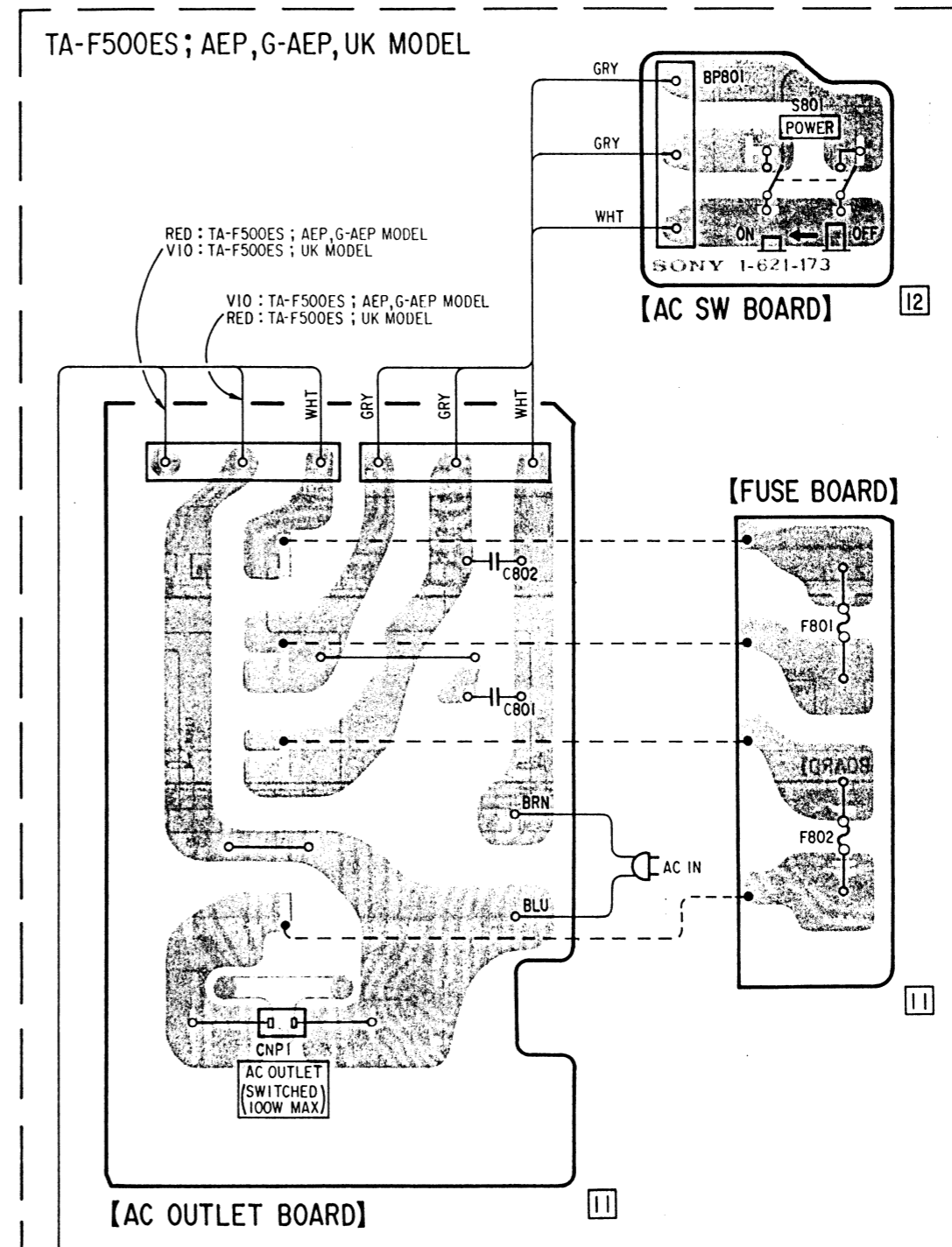

SECTION 2  
DIAGRAMS

2-1. POWER SUPPLY SECTION MOUNTING DIAGRAM - G-AEP, AEP, UK, E Model -

- See page 10 for Semiconductor Lead Layouts.
- See page 14 for US, Canadian model Power Supply Section.
- See page 19 for Circuit Boards Location.

Note:

- Color code or sleeving over the end of the jacket.
- ○ : parts extracted from the component side.
- ● : parts extracted from the conductor side.

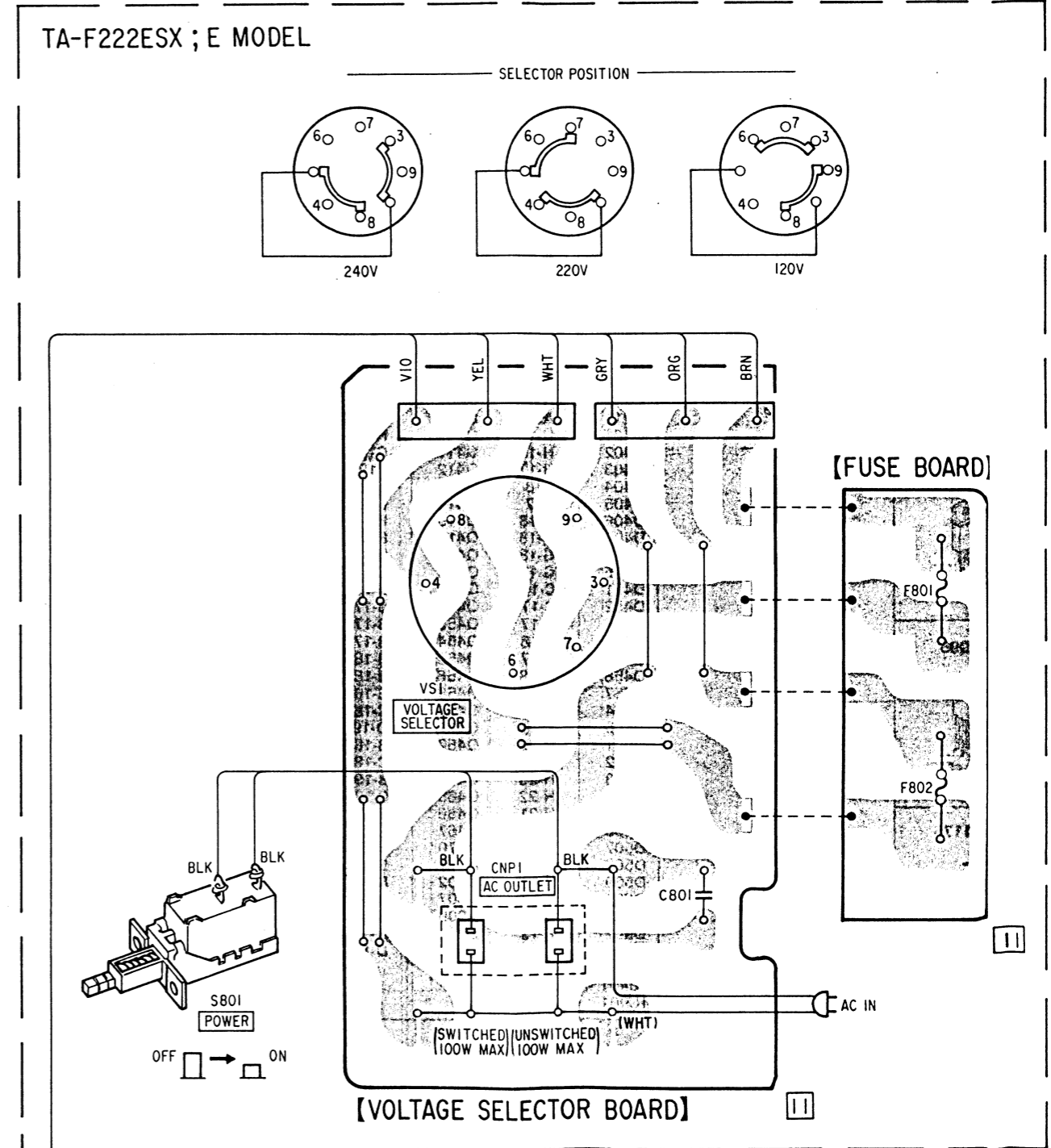
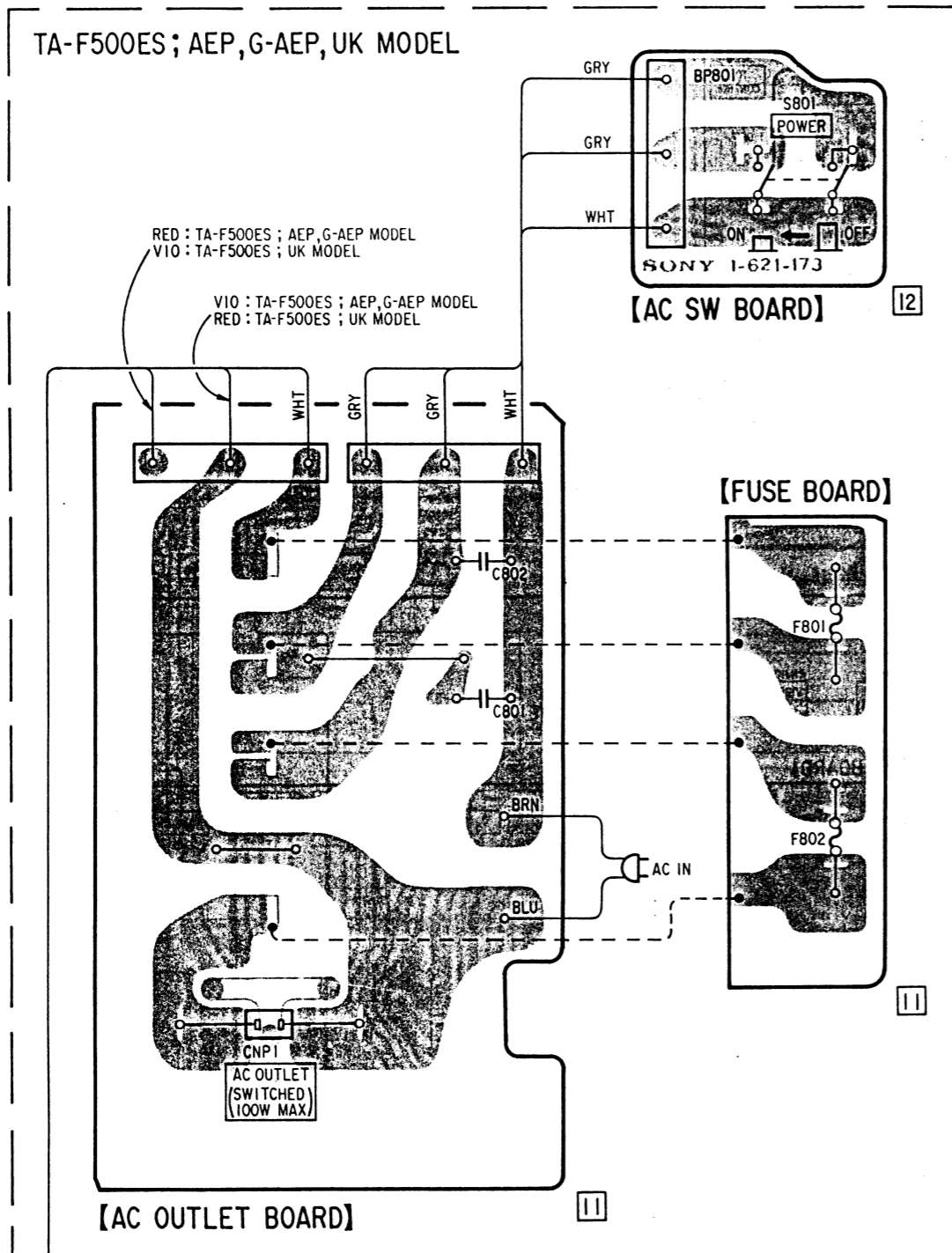
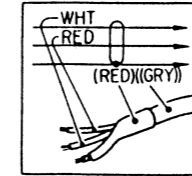



## 2-2. MOUNTING DIAGRAM

- See page 7 for G-AEP, AEP, UK, E model Power Supply Section.
- See page 19 for Circuit Boards Location.

### • Semiconductor Lead Layouts

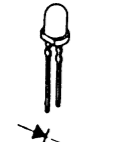
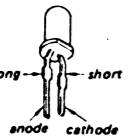
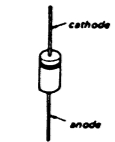
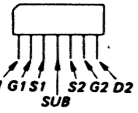
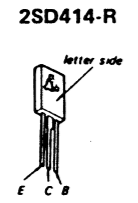
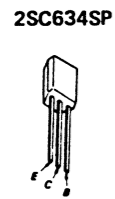
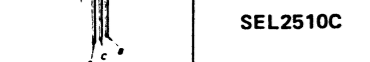
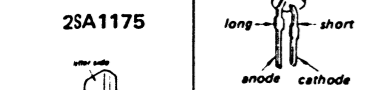
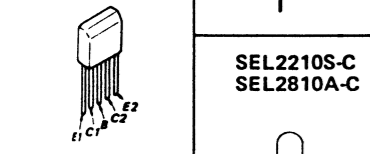
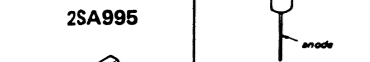
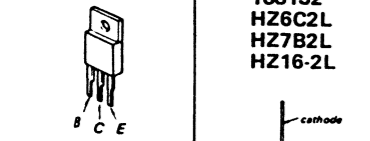
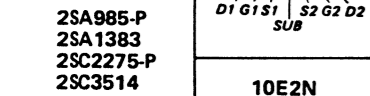
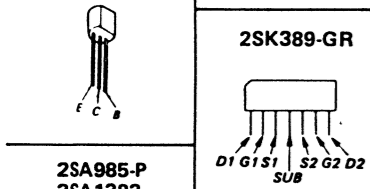
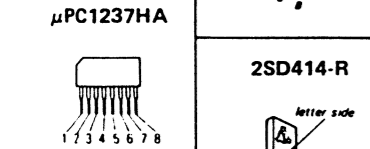
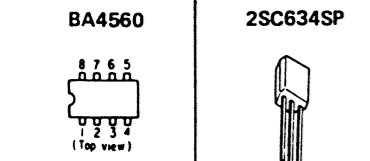

### Note:

- Color code or sleeving over the end of the jacket.

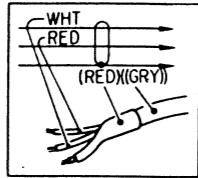

- ○ : parts extracted from the component side.
- ● : parts extracted from the conductor side.
- ■ : part mounted on the conductor side.

### • SEMICONDUCTOR LOCATION

Ref. No.	Location	Ref. No.	Location
D201	D-3	Q201	E-3
D202	D-3	Q202	E-3
D203	E-3	Q203	E-2
D204	E-3	Q204	D-3
D205	D-2	Q401	I-16
D206	D-8	Q402	I-17
D207	A-2	Q403	I-17
D208	A-2	Q404	I-17
D209	A-1	Q405	I-17
D210	A-2	Q406	I-18
D211	A-2	Q408	H-16
D401	H-17	Q409	H-18
D402	H-17	Q411	G-19
D403	H-17	Q412	I-18
D404	I-18	Q413	H-18
D405	I-17	Q414	I-19
D406	G-18	Q415	H-19
D407	G-18	Q416	F-19
D414	G-18	Q417	H-19
D415	G-18	Q420	G-18
D451	C-17	Q451	B-16
D452	C-17	Q452	B-17
D453	C-17	Q453	B-17
D454	B-18	Q454	B-17
D455	C-17	Q455	B-18
D456	D-18	Q456	B-18
D457	D-18	Q458	C-16
D464	E-18	Q459	C-18
D465	E-18	Q461	D-19
D501	H-22	Q462	B-18
D502	H-22	Q463	C-18
D503	H-23	Q464	B-19
D504	H-22	Q465	C-19
D505	H-21	Q466	E-19
D506	H-21	Q467	D-19
D507	H-21	Q470	E-18
D508	H-20	Q901	D-13
D509	H-21	Q902	D-13
D601	C-22	Q907	F-14
D901	F-13	Q909	F-13
D902	F-13	Q951	D-14
D903	F-13	Q952	D-14
IC401	F-16		
IC901	D-13		

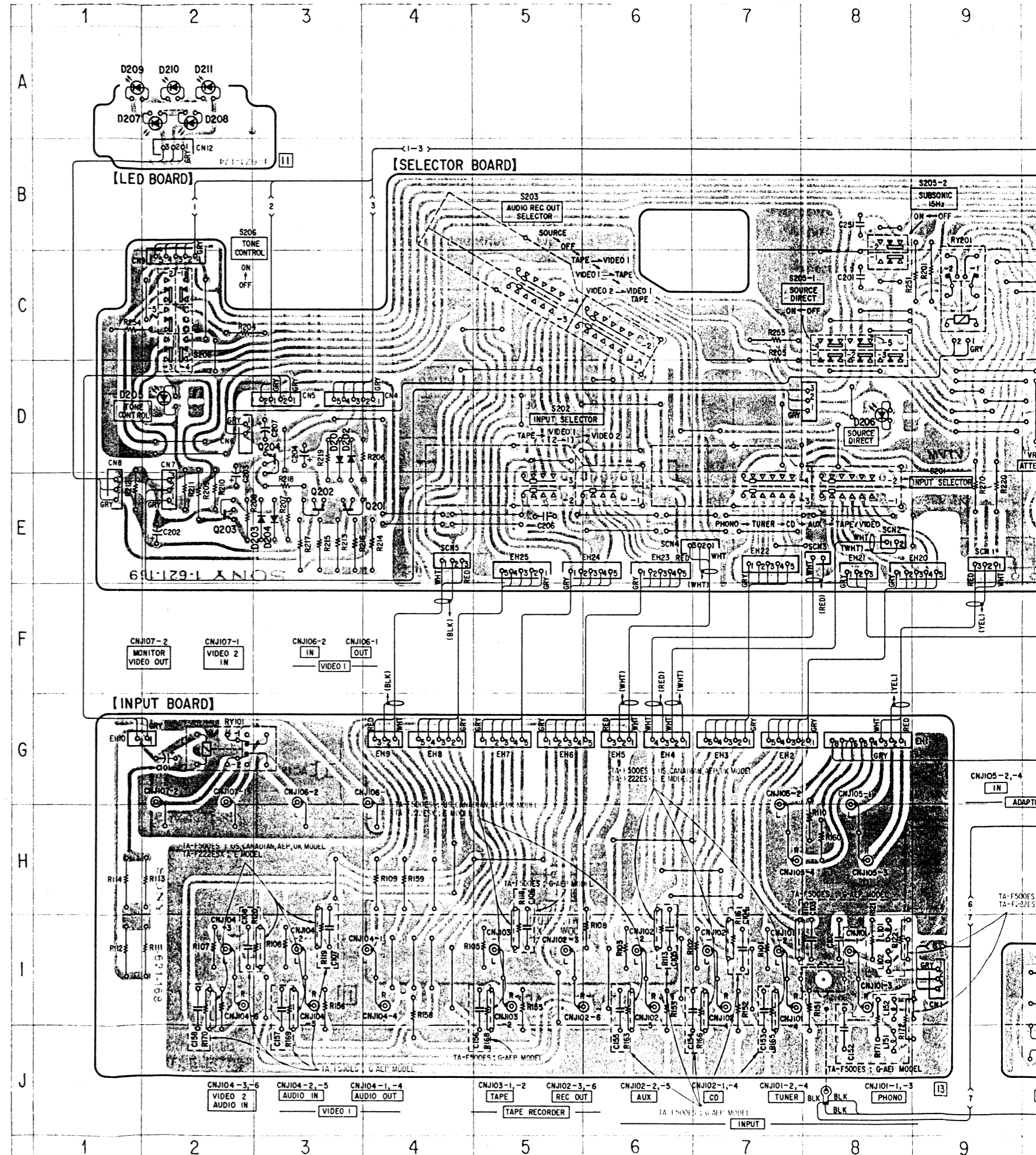



Section.

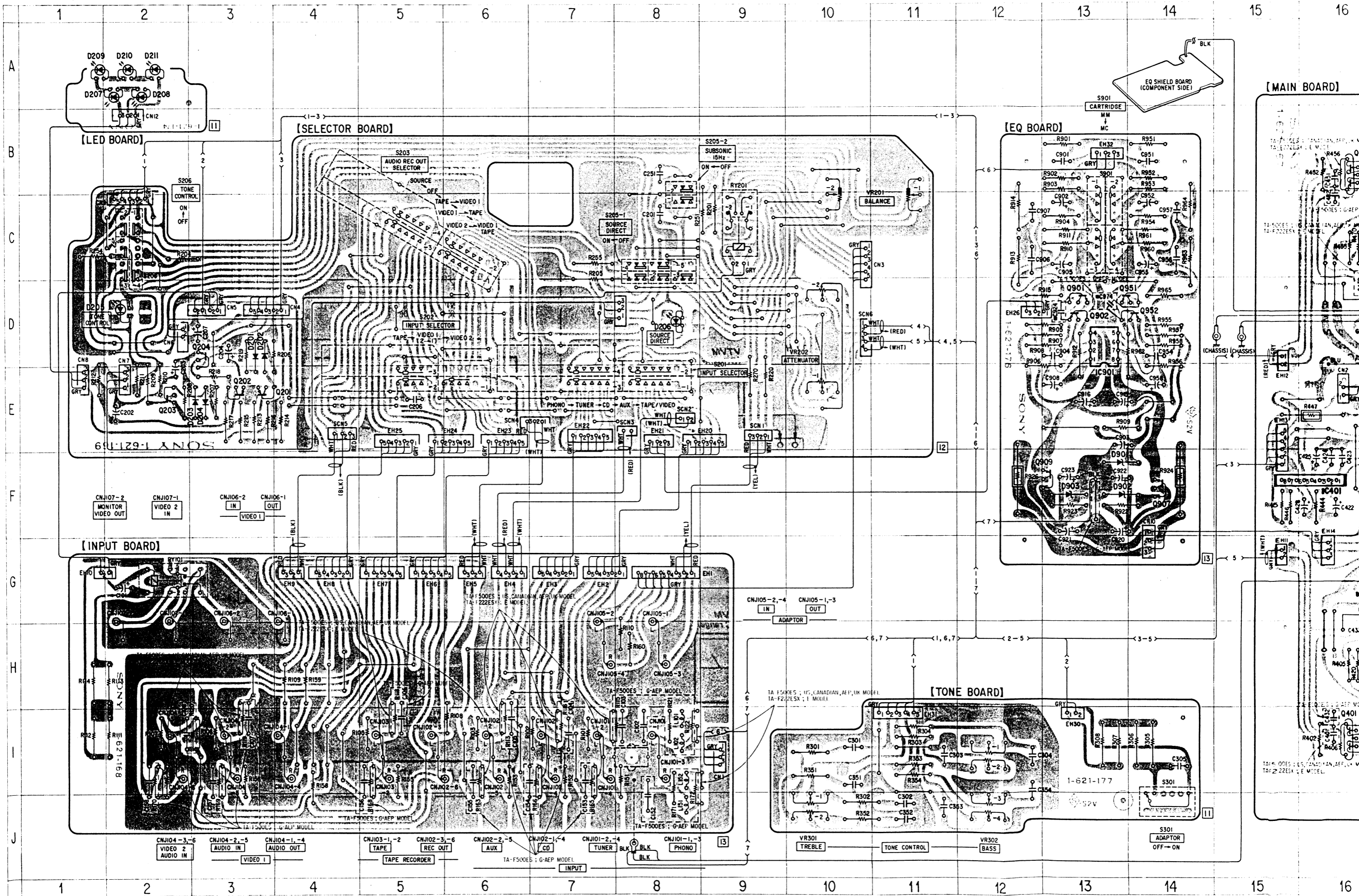

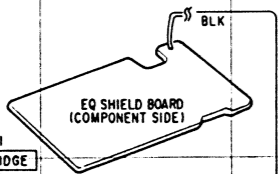

[EQ BOARD]

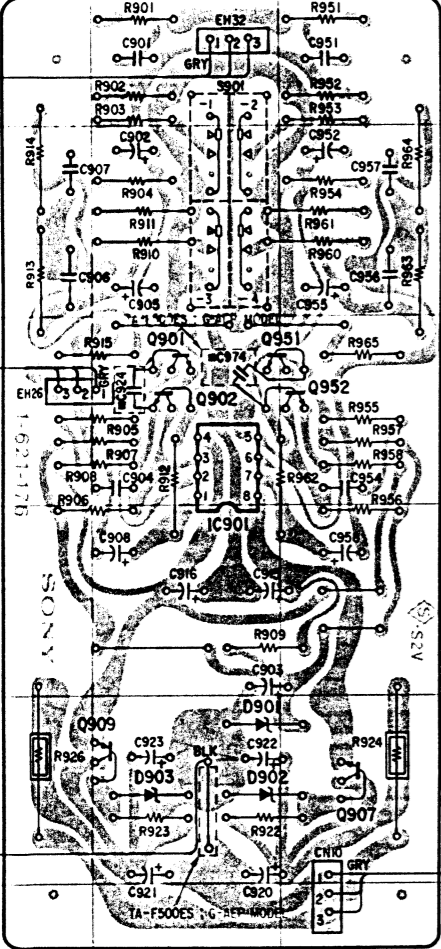

[MAIN BOARD]

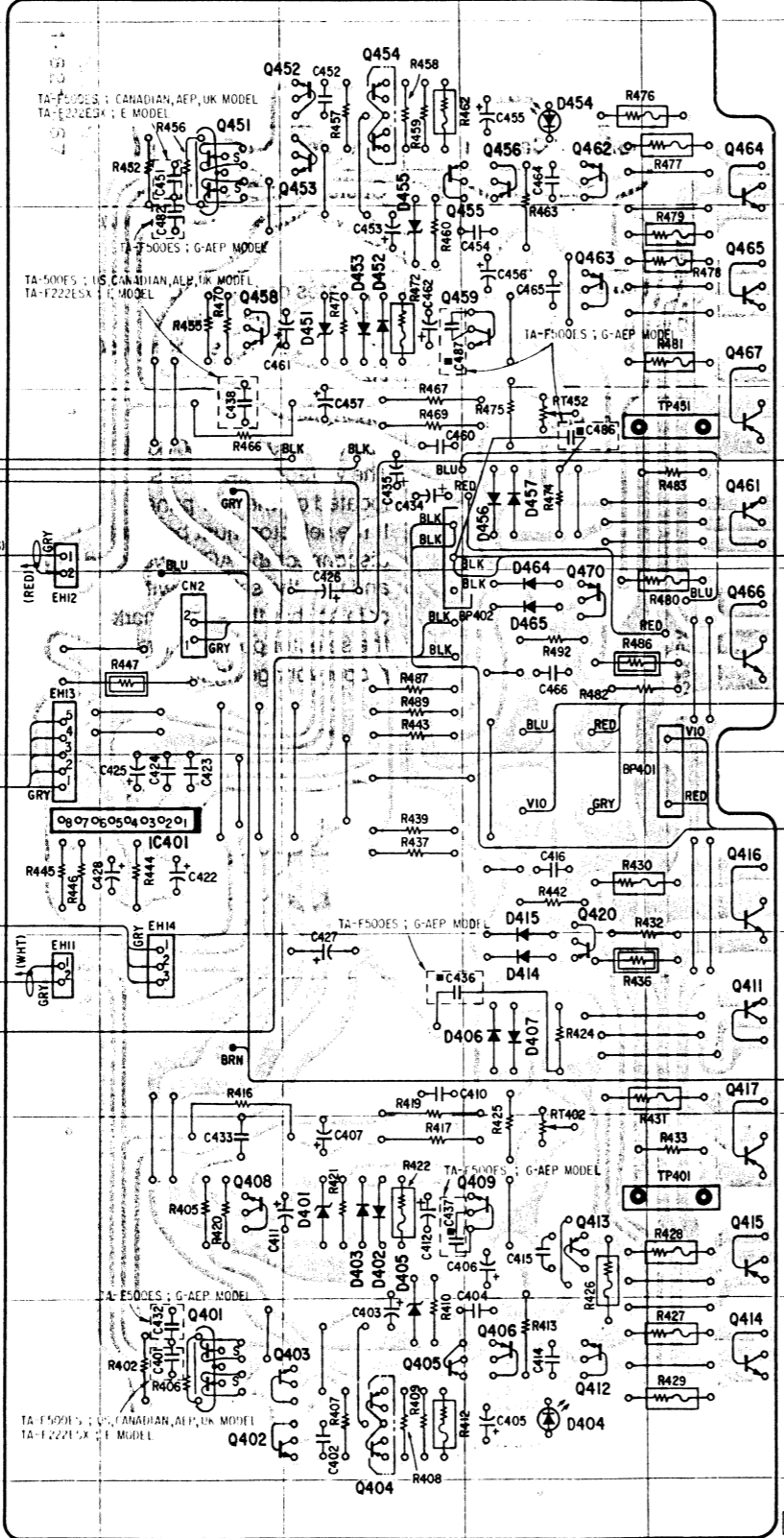

[H.P BOARD]

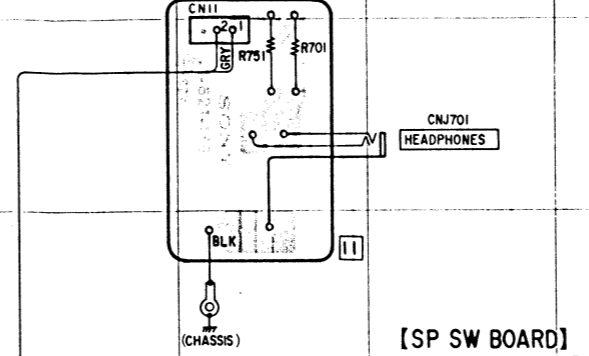

[SP SW BOARD]

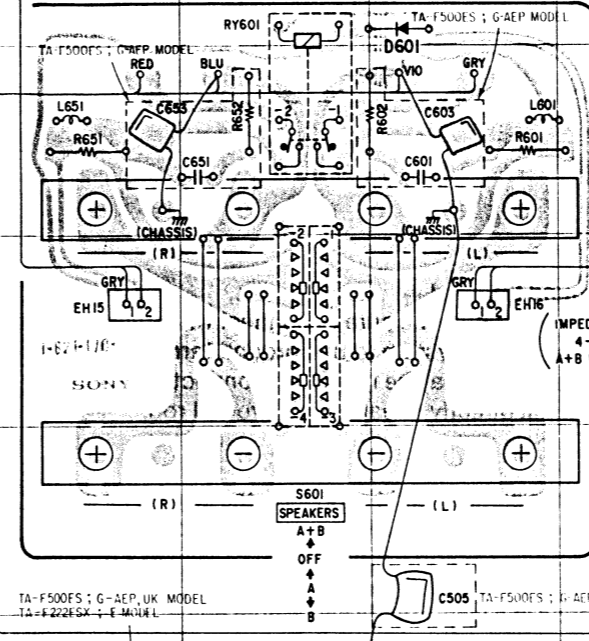

TA-F500ES; US, CANADIAN MODEL [AC OUTLET BOARD]

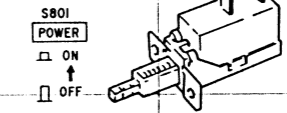
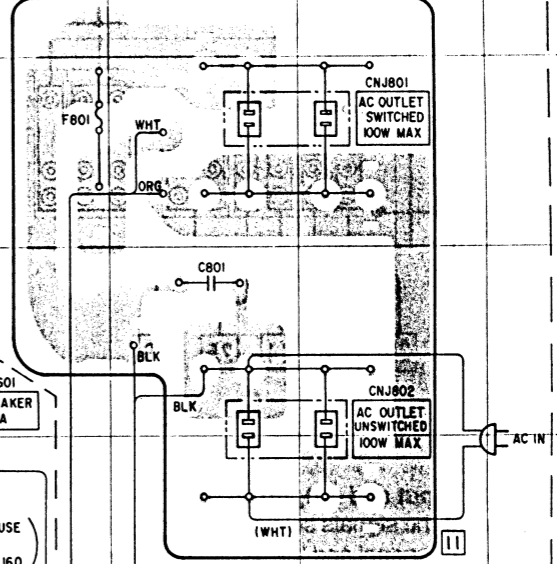

[POWER BOARD]

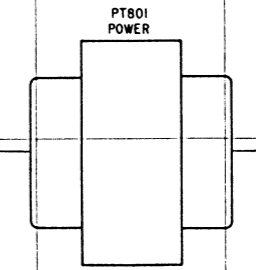
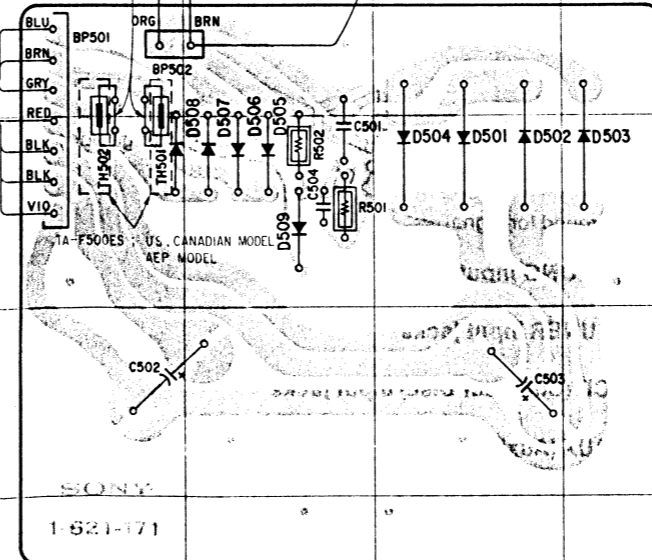

[TONE BOARD]

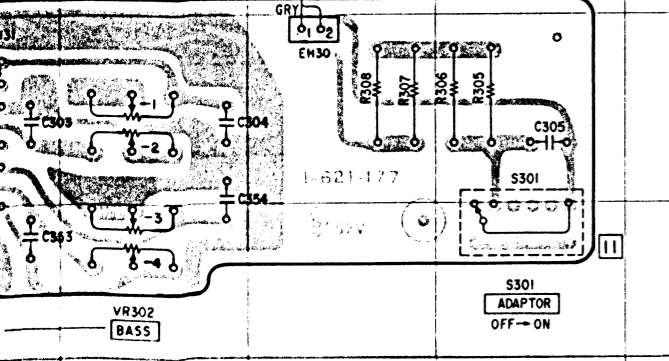

TA-F222ESX/F500ES TA-F222ESX/F500ES

2-3. SCHEMATIC DIAGRAM

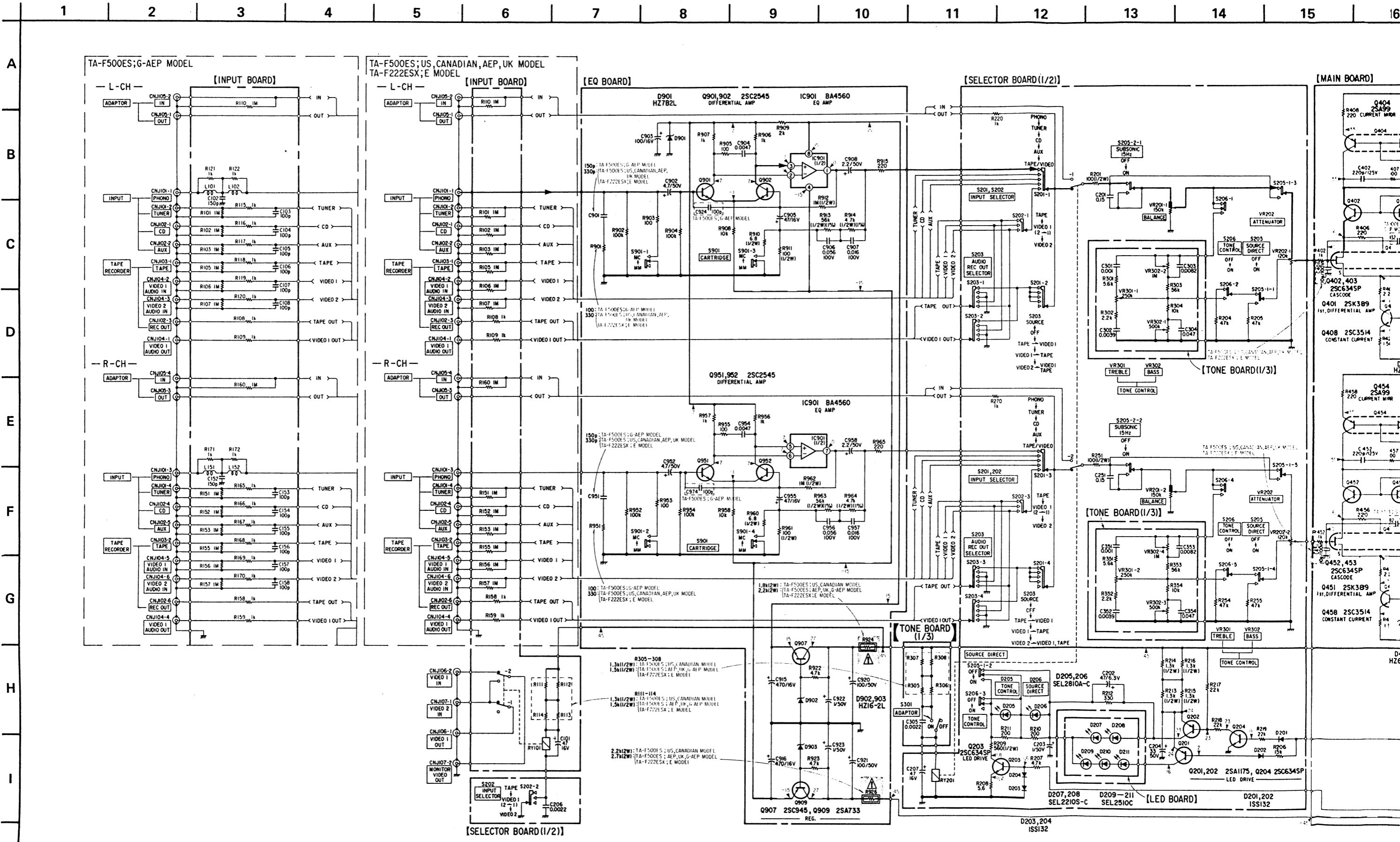



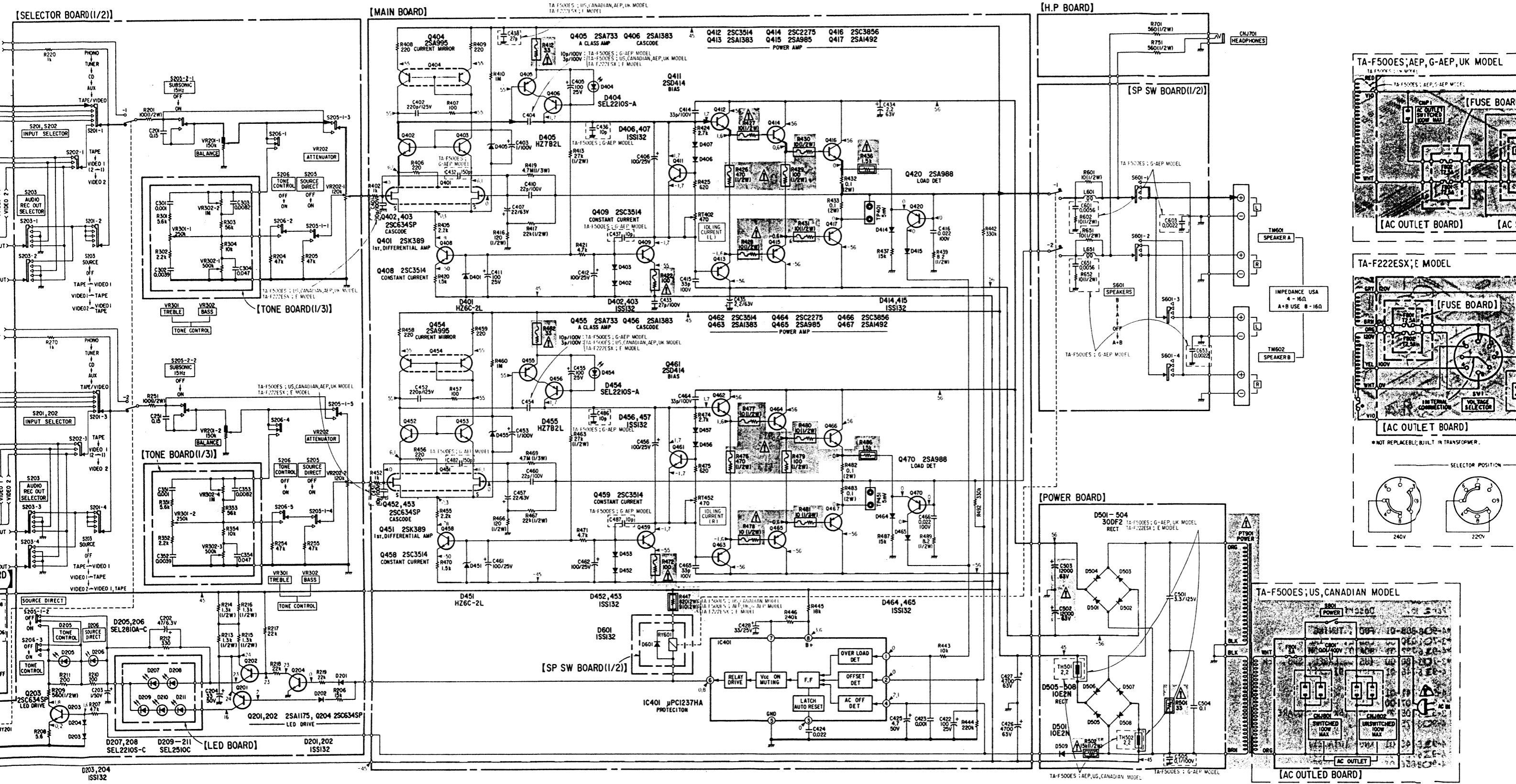

19 20 21 22 23 24 25 26 27 28 29

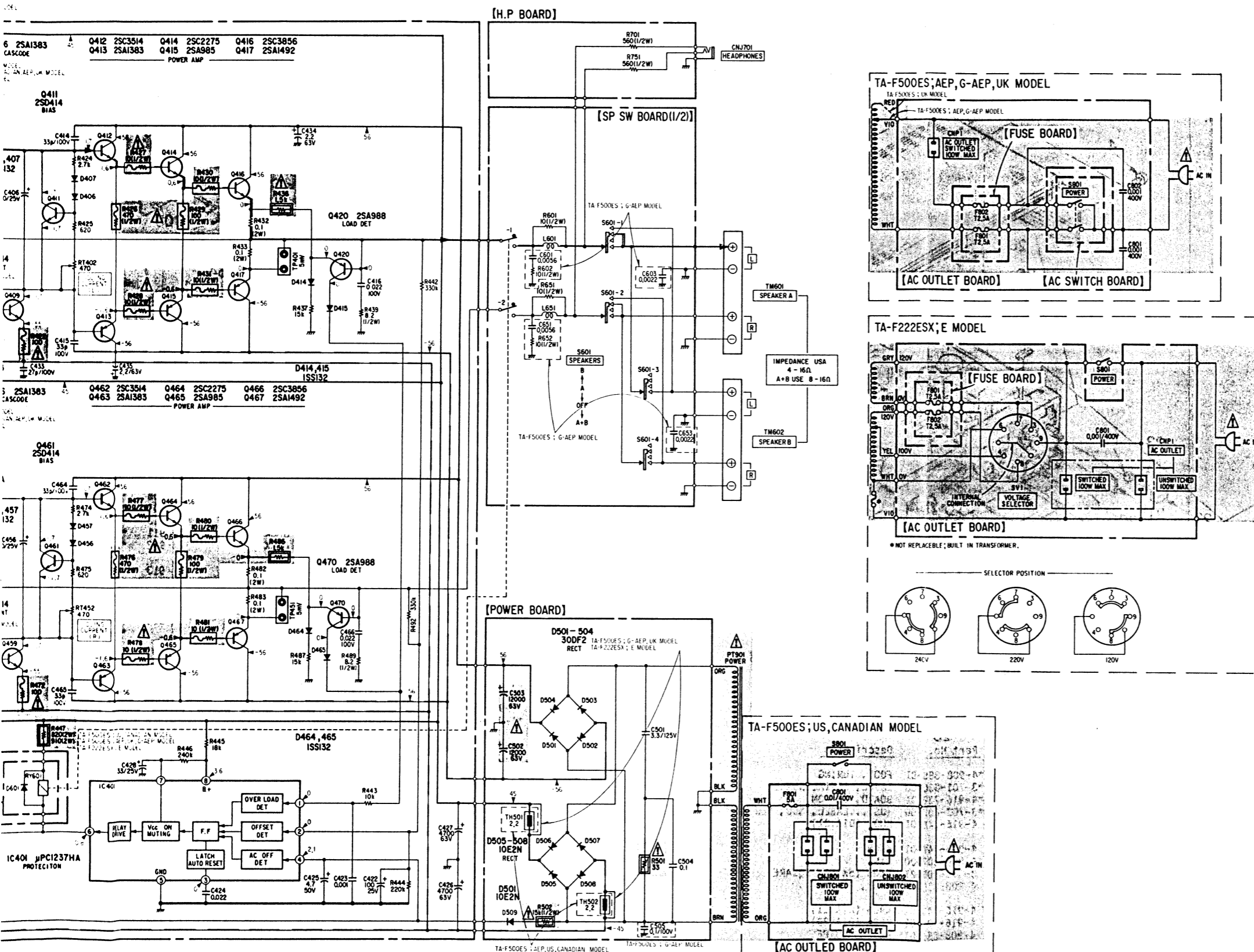

A  
B  
C  
D  
E  
F  
G  
H  
I

Note:

- All capacitors are in  $\mu\text{F}$  unless otherwise noted.  $\text{pF}$ :  $\mu\text{pF}$  50WV or less are not indicated except for electrolytics and tantalums.
- All resistors are in  $\Omega$  and  $\frac{1}{4}$  W or less unless otherwise specified.
- : signal path.
- : nonflammable resistor.
- : fusible resistor.
- +— : B+ bus.
- : B- bus.
- : adjustment for repair.
- Voltages are dc with respect to ground unless otherwise noted.
- Readings are taken under no-signal conditions with a VOM (50  $\text{k}\Omega/\text{V}$ ).
- Switch

Ref. No.	Switch	Position
S201	INPUT SELECTOR	PHONO
S202	INPUT SELECTOR	TAPE
S203	AUDIO REC OUT SELECTOR	SOURCE
S205	TONE CONTROL	OFF
S206	SOURCE DIRECT	OFF
S301	ADAPTOR	OFF
S601	SPEAKERS	A
S801	POWER	OFF
S901	CARTRIDGE	MM
VS1	VOLTAGE SELECTOR	

Note: The components identified by shading and mark are critical for safety. Replace only with part number specified.

Note: Les composants identifiés par un trame et une marque sont critiques pour la sécurité. Ne les remplacer que par une pièce portant le numéro spécifié.

CIRCUIT BOARDS LOCATION

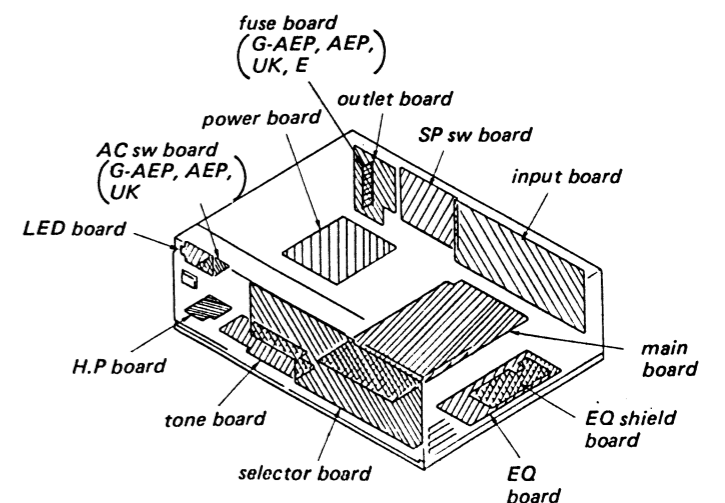

SECTION 3  
EXPLODED VIEWS AND PARTS LIST

NOTE:  
 · The mechanical parts with no reference number in the exploded views are not supplied.  
 · Items marked " \* " are not stocked since they are seldom required for routine service. Some delay should be anticipated when ordering these items.  
 · The construction parts of an assembled part are indicated with a collation number in the remark column.

The components identified by shading and mark  $\Delta$  are critical for safety. Replace only with part number specified.  
 Les composants identifiés par une trame et une marque  $\Delta$  sont critiques pour la sécurité. Ne les remplacer que par une pièce portant le numéro spécifié.

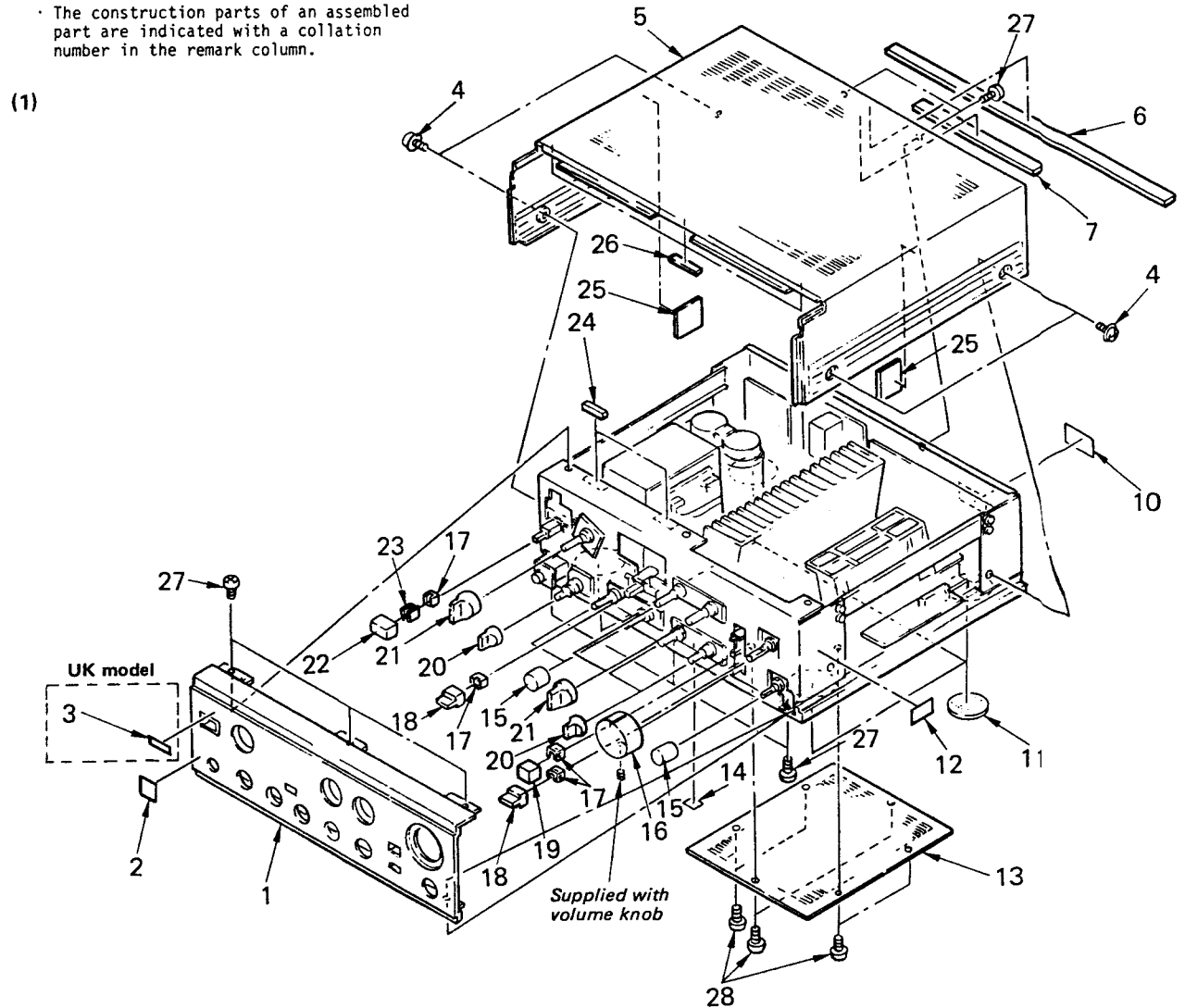

No.	Part No.	Description	Remarks
1	A-4322-882-A A-4322-931-A	(E).....PANEL ASSY, FRONT (G-AEP,AEP,UK,US,Canadian) .....PANEL ASSY, FRONT	
2	3-703-710-41	STICKER, SONY SYMBOL (12)	
3	3-701-690-00	(UK)...LABEL (MADE IN JAPAN)	
4	4-847-802-00	SCREW	
5	4-916-737-01	CASE	
6	*4-848-642-00	CUSHION, VIBRATION	
7	4-916-782-31	DAMPER	
10	*4-916-770-01 *4-916-771-01 *4-916-772-01 *4-916-773-01 *4-916-774-01 *4-916-775-01	(AEP).....LABEL, MODEL NUMBER (Canadian)...LABEL, MODEL NUMBER (US).....LABEL, MODEL NUMBER (E).....LABEL, MODEL NUMBER (UK).....LABEL, MODEL NUMBER (G-AEP).....LABEL, MODEL NUMBER (AE4)	

No.	Part No.	Description	Remarks
11	*4-908-888-01	FOOT, TUNING	
12	*3-701-030-00	LABEL, SERIAL NUMBER	
13	*4-916-732-01	BOARD, BOTTOM	
14	*3-703-680-00	(US)...LABEL, SUB, NEW UL	
15	4-916-746-01	KNOB (DIA.21)	
16	4-916-741-01	KNOB	
17	*4-864-307-00	RING	
18	3-315-105-21	KNOB (5X16), SQUARE	
19	4-908-875-01	KNOB, SQUARE	
20	4-916-745-01	KNOB (DIA.21)	
21	4-916-729-01	KNOB (DIA.29)	
22	4-908-856-01	KNOB, SQUARE	
23	*4-916-762-01	SPACER, KNOB	
24	*4-916-764-01	SPACER (A)	
25	*4-916-757-01	CUSHION	
26	*4-916-767-01	SHEET (F), DAMPER	
27	7-682-147-09	SCREW +BVTT 3X6 (S)	
28	7-685-647-79	SCREW +BVTP 3X10 TYPE2 17-3	



# TA-F22ESX/F500ES

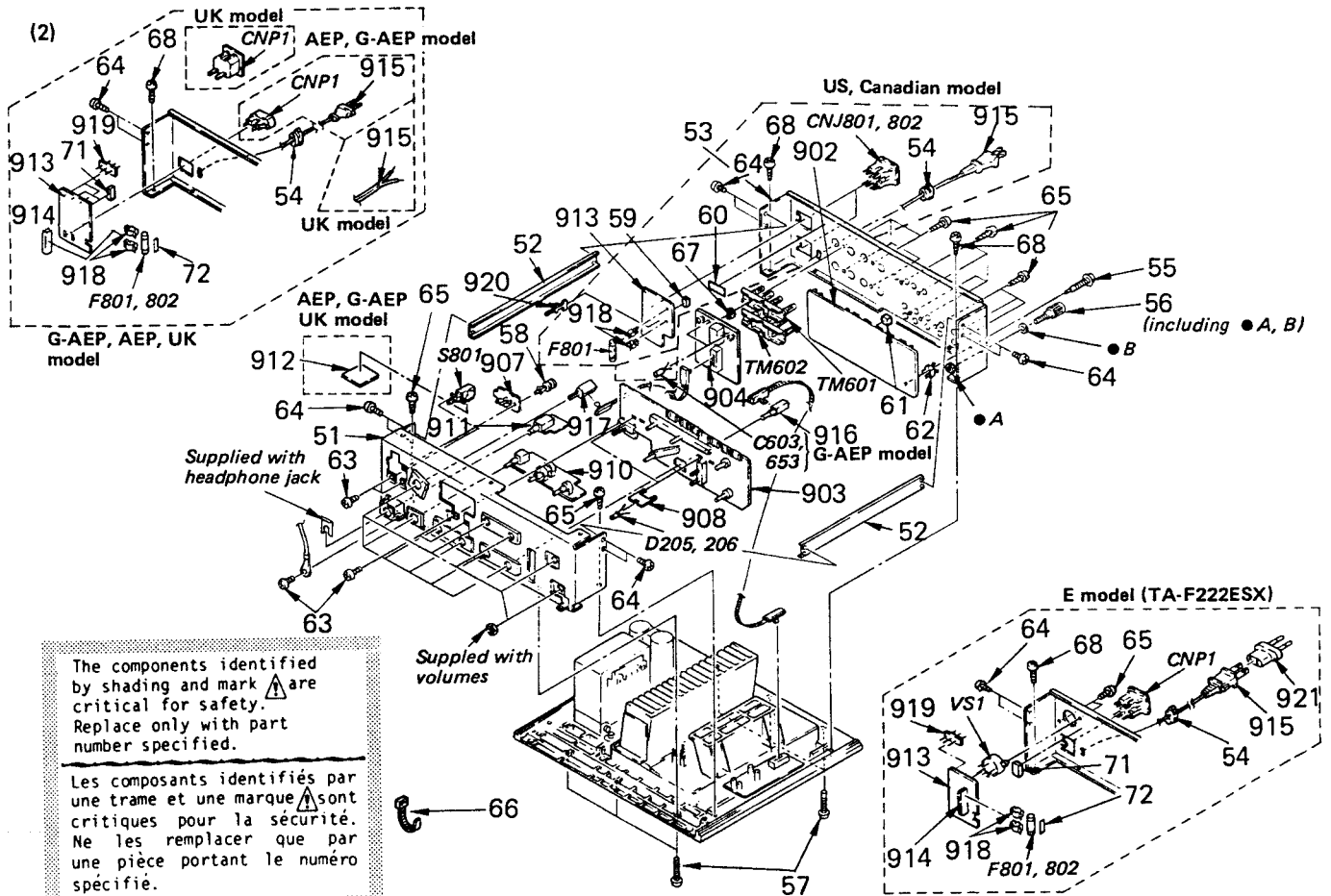

The components identified by shading and mark are critical for safety. Replace only with part number specified.

Les composants identifiés par une trame et une marque sont critiques pour la sécurité. Ne les remplacer que par une pièce portant le numéro spécifié.

No.	Part No.	Description	Remarks	No.	Part No.	Description	Remarks
51	*4-916-738-01	CHASSIS, FRONT		908	*1-621-175-11	PC BOARD, HOLD	
52	*4-916-730-01	PLATE, RELAY		909	*1-621-176-11	PC BOARD, EQ	
53	*4-916-734-11	(US,Canadian)...PLATE, JACK		910	*1-621-177-11	PC BOARD, TONE	
	*4-916-778-01	(E).....PLATE, JACK		911	*1-621-179-11	PC BOARD, H.P	
	*4-916-779-01	(UK).....PLATE, JACK		912	*1-621-173-11	(G-AEP,AEP,UK)...PC BOARD, AC SW	
	*4-916-780-01	(AEP).....PLATE, JACK		913	*1-619-928-11	(E).....PC BOARD, V.S	
	*4-916-780-11	(G-AEP).....PLATE, JACK			*1-619-930-11	(G-AEP,AEP,UK)...PC BOARD, OUTLET	
54	*3-703-244-00	BUSHING (2104), CORD			*1-621-178-11	(US,Canadian)...PC BOARD, AC OUTLET	
55	4-904-486-01	SCREW (F.U), GROUND		914	*1-619-929-11	(E).....PC BOARD, FUSE	
56	X-4854-207-0	TERMINAL ASSY, GROUND			*1-619-931-11	(G-AEP,AEP,UK)...PC BOARD, FUSE (AE)	
57	7-685-876-09	SCREW +BVTT 3X16 (S)		915	1-555-380-00	(E).....CORD, POWER	
58	4-812-134-00	RIVET NYLON, 3.5			1-555-795-00	(AEP,G-AEP).....CORD, POWER	
59	*4-916-760-01	(US,Canadian)...CUSHION (B), PC BOARD			1-556-035-00	(UK).....CORD, POWER	
60	*3-703-044-26	(US,Canadian)...LABEL, CAUTION			1-557-577-11	(US,Canadian)...CORD, POWER	
61	4-916-760-01	CUSHION (A), PC BOARD		916	1-570-891-11	SWITCH, ROTARY SLIDE (REMOTE)	
62	*4-904-485-01	PLATE (F.U), GROUND		917	1-570-894-11	SWITCH, ROTARY SLIDE (REMOTE)	
63	7-682-147-01	SCREW +BVTT 3X6 (S)		918	1-533-183-11	HOLDER, FUSE	
64	7-682-147-09	SCREW +BVTT 3X6 (S)		919	*1-535-136-00	(G-AEP,AEP,UK,E) ...BASE POST 14MM (10MM PITCH) 3P	
65	7-685-647-79	SCREW +BVTP 3X10 TYPE2 IT-3		920	*1-535-476-11	TERMINAL	
66	3-655-653-21	BAND (TAITON), BINDING		921	1-526-565-00	(E)...AC PLUG ADAPTOR	
67	*4-843-416-11	PLATE, FIXED, CAP		CNJ801	1-526-883-00	(US,Canadian)...OUTLET, AC	
68	4-887-711-21	(G-AEP)...SCREW, TERMINAL, CLAW, + BVTP		CNJ802	1-526-883-00	(US,Canadian)...OUTLET, AC	
	7-685-647-79	(AEP,UK,E,US,Canadian). ...SCREW +BVTP 3X10 TYPE2 IT-3		CNP1	1-526-751-11	(UK).....OUTLET, AC	
71	*4-916-707-01	(AEP,G-AEP,UK,E)...CUSHION		CNP1	1-526-794-11	(AEP,G-AEP)...OUTLET, AC	
72	3-701-948-18	LABEL, FUSE		CNP1	1-526-883-00	(E).....OUTLET, AC	
902	*1-621-168-11	PC BOARD, INPUT		F801	1-532-272-XX	(US,Canadian).....FUSE 5A	
903	*1-621-169-11	PC BOARD, SELECTOR		F801	1-532-286-00	(G-AEP,AEP,UK,E)...FUSE, TIME-LAG T2.5A	
904	*1-621-170-11	PC BOARD, SP SW		F802	1-532-286-00	(G-AEP,AEP,UK,E)...FUSE, TIME-LAG T2.5A	
905	*1-621-171-11	PC BOARD, POWER		S801	1-554-880-11	(G-AEP,AEP,UK)...SWITCH, PUSH (AC POWER)(1 KEY)	
906	*1-621-172-11	PC BOARD, EQ SHIELD		S801	1-554-920-11	(E,US,Canadian)...SWITCH, PUSH(AC POWER)	
907	*1-621-174-11	PC BOARD, LED		TM601	1-536-767-21	TERMINAL BOARD, SPEAKER	
				TM602	1-536-767-21	TERMINAL BOARD, SPEAKER	



## SECTION 4 ELECTRICAL PARTS LIST

**NOTE:**

- Items marked " \* " are not stocked since they are seldom required for routine service. Some delay should be anticipated when ordering these items.
- If there are two or more same circuits in a set such as a stereophonic machine, only typical circuit parts may be indicated and capacitors and resistors in other same circuits may be omitted.

**CAPACITORS:**

MF:µF, PF:µµF.

**RESISTORS**

- All resistors are in ohms.
- F : nonflammable

**COILS**

MMH : mH, UH : µH

**SEMICONDUCTORS**

In each case, U : µ, for example:

UA... : µA..., UPA... : µPA..., UPC... : µPC, UPD... : µPD...

The components identified by shading and mark  $\Delta$  are critical for safety. Replace only with part number specified.

Les composants identifiés par une trame et une marque  $\Delta$  sont critiques pour la sécurité. Ne les remplacer que par une pièce portant le numéro spécifié.

ELECTRICAL PARTS

Ref.No.	Part No.	Description
901	*A-4410-473-A	MOUNTED PCB, MAIN
902	*1-621-168-11	PC BOARD, INPUT
903	*1-621-169-11	PC BOARD, SELECTOR
904	*1-621-170-11	PC BOARD, SP SW
905	*1-621-171-11	PC BOARD, POWER
906	*1-621-172-11	PC BOARD, EQ SHIELD
907	*1-621-174-11	PC BOARD, LED
908	*1-621-175-11	PC BOARD, HOLD
909	*1-621-176-11	PC BOARD, EQ
910	*1-621-177-11	PC BOARD, TONE
911	*1-621-179-11	PC BOARD, H.P
912	*1-621-173-11	PC BOARD, AC SW
913	*1-619-928-11	(E).....PC BOARD, V.S
	*1-619-930-11	(G-AEP,AEP,UK)...PC BOARD, OUTLET
	*1-621-178-11	(US,Canadian)...PC BOARD, AC OUTLET
914	*1-619-929-11	(E).....PC BOARD, FUSE
	*1-619-931-11	(G-AEP,AEP,UK)...PC BOARD, FUSE (AE)
915	$\Delta$ 1-555-380-00	(E).....CORD, POWER
	$\Delta$ 1-555-795-00	(AEP,G-AEP)...CORD, POWER
	$\Delta$ 1-556-035-00	(UK).....CORD, POWER
	$\Delta$ 1-557-577-11	(US,Canadian)...CORD, POWER
916	1-570-891-11	SWITCH, ROTARY SLIDE (REMOTE)
917	1-570-894-11	SWITCH, ROTARY SLIDE (REMOTE)
918	1-533-183-11	HOLDER, FUSE
919	*1-535-136-00	(G-AEP,AEP,UK,E)...BASE POST 14MM (10MM PITCH) 3P
920	*1-535-476-11	TERMINAL
921	$\Delta$ 1-526-565-00	(E)...AC PLUG ADAPTOR
BP401	*1-535-135-00	BASE POST 14MM (10MM PITCH) 2P
BP402	*1-508-810-00	BASE POST (14MM)
BP501	*1-535-120-00	TERMINAL
BP502	*1-535-115-00	TERMINAL
C101	1-124-126-00	ELECT 47MF 20% 16V
C102	1-162-284-31	(G-AEP)...CERAMIC 150PF 10% 50V
C103	1-161-271-00	(G-AEP)...CERAMIC 100PF 5% 50V
C104	1-161-271-00	(G-AEP)...CERAMIC 100PF 5% 50V
C105	1-161-271-00	(G-AEP)...CERAMIC 100PF 5% 50V
C106	1-161-271-00	(G-AEP)...CERAMIC 100PF 5% 50V
C107	1-161-271-00	(G-AEP)...CERAMIC 100PF 5% 50V
C108	1-161-271-00	(G-AEP)...CERAMIC 100PF 5% 50V
C152	1-162-284-31	(G-AEP)...CERAMIC 150PF 10% 50V
C153	1-161-271-00	(G-AEP)...CERAMIC 100PF 5% 50V
C154	1-161-271-00	(G-AEP)...CERAMIC 100PF 5% 50V
C155	1-161-271-00	(G-AEP)...CERAMIC 100PF 5% 50V
C156	1-161-271-00	(G-AEP)...CERAMIC 100PF 5% 50V
C157	1-161-271-00	(G-AEP)...CERAMIC 100PF 5% 50V
C158	1-161-271-00	(G-AEP)...CERAMIC 100PF 5% 50V

ELECTRICAL PARTS

Ref.No.	Part No.	Description
C201	1-136-167-00	FILM 0.15MF 5% 50V
C202	1-123-306-00	ELECT 47MF 20% 6.3V
C203	1-123-380-00	ELECT 1MF 20% 50V
C204	1-123-382-00	ELECT 33MF 20% 50V
C206	1-130-475-00	MYLAR 0.0022MF 5% 50V
C207	1-124-126-00	ELECT 47MF 20% 16V
C251	1-136-167-00	FILM 0.15MF 5% 50V
C301	1-130-471-00	MYLAR 0.001MF 5% 50V
C302	1-130-478-00	MYLAR 0.0039MF 5% 50V
C303	1-130-482-00	MYLAR 0.0082MF 5% 50V
C304	1-136-161-00	FILM 0.047MF 5% 50V
C305	1-130-475-00	MYLAR 0.0022MF 5% 50V
C351	1-130-471-00	MYLAR 0.001MF 5% 50V
C352	1-130-478-00	MYLAR 0.0039MF 5% 50V
C353	1-130-482-00	MYLAR 0.0082MF 5% 50V
C354	1-136-161-00	FILM 0.047MF 5% 50V
C401	1-107-202-00	(AEP,UK,E,US,Canadian) ...MICA 10PF 100V
C402	1-104-233-00	POLYSTYRENE 220PF 5% 125V
C403	1-123-380-00	ELECT 1MF 20% 100V
C404	1-107-202-00	(G-AEP)...MICA 10PF 0.5PF 100V
C404	1-107-276-11	(AEP,UK,E,US,Canadian) ...MICA 3PF 100V
C405	1-123-333-00	ELECT 100MF 20% 25V
C406	1-123-333-00	ELECT 100MF 20% 25V
C407	1-124-929-11	ELECT 22MF 20% 63V
C410	1-107-210-00	MICA 22PF 5% 100V
C411	1-123-333-00	ELECT 100MF 20% 25V
C412	1-123-333-00	ELECT 100MF 20% 25V
C414	1-107-159-00	MICA 33PF 5% 100V
C415	1-107-159-00	MICA 33PF 5% 100V
C416	1-130-973-00	FILM 0.022MF 10% 100V
C422	1-123-333-00	ELECT 100MF 20% 25V
C423	1-130-471-00	MYLAR 0.001MF 5% 50V
C424	1-136-157-00	FILM 0.022MF 5% 50V
C425	1-123-369-00	ELECT 4.7MF 20% 50V
C426	1-125-459-11	ELECT(BLOCK) 4700MF 20% 63V
C427	1-125-459-11	ELECT(BLOCK) 4700MF 20% 63V
C428	1-123-343-00	ELECT 33MF 20% 25V
C432	1-102-108-00	(G-AEP)...CERAMIC 150PF 10% 50V
C433	1-107-157-00	MICA 27PF 5% 100V
C434	1-123-381-00	ELECT 2.2MF 20% 63V
C435	1-123-381-00	ELECT 2.2MF 20% 63V
C436	1-102-947-00	(G-AEP)...CERAMIC 10PF 5% 50V
C437	1-102-947-00	(G-AEP)...CERAMIC 10PF 5% 50V

### ELECTRICAL PARTS

Ref.No.	Part No.	Description			
C438	1-107-157-00	MICA 27PF	5%	100V	
C451	1-107-202-00	(AEP,UK,E,US,Canadian) ...MICA 10PF		100V	
C452	1-104-233-00	POLYSTYRENE 220PF	5%	125V	
C453	1-123-380-00	ELECT 1MF	20%	100V	
C454	1-107-202-00	(G-AEP)...MICA 10PF	0.5PF	100V	
C454	1-107-276-11	(AEP,UK,E,US,Canadian) ...MICA 3PF		100V	
C455	1-123-333-00	ELECT 100MF	20%	25V	
C456	1-123-333-00	ELECT 100MF	20%	25V	
C457	1-124-929-11	ELECT 22MF	20%	63V	
C460	1-107-210-00	MICA 22PF	5%	100V	
C461	1-123-333-00	ELECT 100MF	20%	25V	
C462	1-123-333-00	ELECT 100MF	20%	25V	
C464	1-107-159-00	MICA 33PF	5%	100V	
C465	1-107-159-00	MICA 33PF	5%	100V	
C466	1-130-973-00	FILM 0.022MF	10%	100V	
C482	1-102-108-00	(G-AEP)...CERAMIC 150PF	10%	50V	
C486	1-102-947-00	(G-AEP)...CERAMIC 10PF	5%	50V	
C487	1-102-947-00	(G-AEP)...CERAMIC 10PF	5%	50V	
C501	1-130-673-00	FILM 3.3MF	10%	125V	
C502	1-125-460-11	CAP, ELECT 12000MF			
C503	1-125-460-11	CAP, ELECT 12000MF			
C504	1-136-165-00	FILM 0.1MF	5%	50V	
C505	1-130-321-00	(G-AEP)..CAP, PP FILM 0.1MF			
C601	1-110-204-00	(G-AEP)..MYLAR 0.0056MF	5%	50V	
C603	1-106-351-00	(G-AEP)..CAP, PE TEREPHTHALATE 0.0022MF			
C651	1-110-204-00	(G-AEP)..MYLAR 0.0056MF	5%	50V	
C653	1-106-351-00	(G-AEP)..CAP, PE TEREPHTHALATE 0.0022MF			
C801	1-161-741-00	(G-AEP,AEP,UK,E) ...CERAMIC 0.001MF	10%	400V	
C801	1-161-744-00	(US,Canadian) ...CERAMIC 0.01MF	10%	400V	
C802	1-161-741-00	(G-AEP,AEP,UK) ...CERAMIC 0.001MF	10%	400V	
C901	1-102-108-00	(G-AEP)...CERAMIC 150PF	10%	50V	
C901	1-102-112-00	(AEP,UK,E,US,Canadian) ...CERAMIC 330PF	10%	50V	
C902	1-123-369-00	ELECT 4.7MF	20%	50V	
C903	1-123-333-00	ELECT 100MF	20%	16V	
C904	1-110-203-00	MYLAR 0.0047MF	5%	50V	
C905	1-123-332-00	ELECT 47MF	20%	16V	
C906	1-130-341-00	FILM 0.056MF	3%	100V	
C907	1-130-971-00	FILM 0.016MF	3%	100V	
C908	1-123-381-00	ELECT 2.2MF	20%	50V	
C915	1-126-103-11	ELECT 470MF	20%	16V	
C916	1-126-103-11	ELECT 470MF	20%	16V	
C920	1-123-360-00	ELECT 100MF	20%	50V	
C921	1-123-360-00	ELECT 100MF	20%	50V	
C922	1-123-380-00	ELECT 1MF	20%	50V	
C923	1-123-380-00	ELECT 1MF	20%	50V	
C924	1-102-106-00	(G-AEP)...CERAMIC 100PF	10%	50V	
C951	1-102-108-00	(G-AEP)...CERAMIC 150PF	10%	50V	
C951	1-102-112-00	(AEP,UK,E,US,Canadian) ...CERAMIC 330PF	10%	50V	
C952	1-123-369-00	ELECT 4.7MF	20%	50V	
C954	1-110-203-00	MYLAR 0.0047MF	5%	50V	
C955	1-123-332-00	ELECT 47MF	20%	16V	

### ELECTRICAL PARTS

Ref.No.	Part No.	Description			
C956	1-130-341-00	FILM 0.056MF	3%	100V	
C957	1-130-971-00	FILM 0.016MF	3%	100V	
C958	1-123-381-00	ELECT 2.2MF	20%	50V	
C974	1-102-106-00	(G-AEP)...CERAMIC 100PF	10%	50V	
CNJ1	*1-562-327-00	SOCKET, CONNECTOR 3P			
CNJ2	*1-562-327-00	SOCKET, CONNECTOR 3P			
CNJ3	*1-562-250-00	SOCKET, CONNECTOR 5P			
CNJ4	*1-562-250-00	SOCKET, CONNECTOR 5P			
CNJ5	*1-562-249-00	SOCKET, CONNECTOR 4P			
CNJ6	*1-562-327-00	SOCKET, CONNECTOR 3P			
CNJ7	*1-562-327-00	SOCKET, CONNECTOR 3P			
CNJ8	*1-562-327-00	SOCKET, CONNECTOR 3P			
CNJ9	*1-562-250-00	SOCKET, CONNECTOR 5P			
CNJ10	*1-562-327-00	SOCKET, CONNECTOR 3P			
CNJ11	*1-562-327-00	SOCKET, CONNECTOR 3P			
CNJ12	*1-562-327-00	SOCKET, CONNECTOR 3P			
CNJ101	1-507-909-11	JACK, PIN 4P			
CNJ102	1-507-914-21	JACK, PIN 6P			
CNJ103	1-507-912-11	JACK, PIN 2P			
CNJ104	1-507-914-21	JACK, PIN 6P			
CNJ105	1-507-909-11	JACK, PIN 4P			
CNJ106	1-562-916-11	JACK, PIN 2P			
CNJ107	1-562-916-11	JACK, PIN 2P			
CNJ701	1-507-863-21	JACK, LARGE TYPE			
CNJ801	1-526-883-00	(US,Canadian) OUTLET, AC			
CNJ802	1-526-883-00	(US,Canadian) OUTLET, AC			
CNP1	1-526-751-11	(UK) OUTLET, AC			
CNP1	1-526-794-11	(AEP,G-AEP) OUTLET, AC			
CNP1	1-526-883-00	(E) OUTLET, AC			
D201	8-719-940-76	DIODE 1SS132			
D202	8-719-940-76	DIODE 1SS132			
D203	8-719-940-76	DIODE 1SS132			
D204	8-719-940-76	DIODE 1SS132			
D205	8-719-301-52	DIODE SEL2810A-C			
D206	8-719-301-52	DIODE SEL2810A-C			
D207	8-719-301-38	DIODE SEL2210S-C			
D208	8-719-301-38	DIODE SEL2210S-C			
D209	8-719-303-00	DIODE SEL2510C			
D210	8-719-303-00	DIODE SEL2510C			
D211	8-719-303-00	DIODE SEL2510C			
D401	8-719-910-68	DIODE HZ6C2L			
D402	8-719-940-76	DIODE 1SS132			
D403	8-719-940-76	DIODE 1SS132			
D404	8-719-301-38	DIODE SEL2210S-A			
D405	8-719-910-75	DIODE HZ7B2L			
D406	8-719-940-76	DIODE 1SS132			
D407	8-719-940-76	DIODE 1SS132			
D414	8-719-940-76	DIODE 1SS132			
D415	8-719-940-76	DIODE 1SS132			
D451	8-719-910-68	DIODE HZ6C2L			
D452	8-719-940-76	DIODE 1SS132			
D453	8-719-940-76	DIODE 1SS132			
D454	8-719-301-38	DIODE SEL2210S-A			
D455	8-719-910-75	DIODE HZ7B2L			
D456	8-719-940-76	DIODE 1SS132			
D457	8-719-940-76	DIODE 1SS132			
D464	8-719-940-76	DIODE 1SS132			
D465	8-719-940-76	DIODE 1SS132			
D501	8-719-230-02	DIODE 30DF2			

The components identified by shading and mark **A** are critical for safety. Replace only with part number specified.

Les composants identifiés par une trame et une marque **A** sont critiques pour la sécurité. Ne les remplacer que par une pièce portant le numéro spécifié.

# TA-F22ESX/F500ES

## ELECTRICAL PARTS

Ref.No.	Part No.	Description
D502	8-719-230-02	DIODE 30DF2
D503	8-719-230-02	DIODE 30DF2
D504	8-719-230-02	DIODE 30DF2
D505	8-719-200-77	DIODE 10E2N
D506	8-719-200-77	DIODE 10E2N
D507	8-719-200-77	DIODE 10E2N
D508	8-719-200-77	DIODE 10E2N
D601	8-719-940-76	DIODE 1S5132
D901	8-719-910-75	DIODE H27B2L
D902	8-719-901-62	DIODE HZ16-2L
D903	8-719-901-62	DIODE HZ16-2L
EH1	1-564-523-41	PLUG, CONNECTOR 8P
EH2	*1-564-520-11	PLUG, CONNECTOR 5P
EH3	*1-564-520-11	PLUG, CONNECTOR 5P
EH4	1-564-519-31	PLUG, CONNECTOR 4P
EH5	*1-564-518-11	PLUG, CONNECTOR 3P
EH6	*1-564-520-11	PLUG, CONNECTOR 5P
EH7	*1-564-520-11	PLUG, CONNECTOR 5P
EH8	*1-564-520-11	PLUG, CONNECTOR 5P
EH9	*1-564-518-21	PLUG, CONNECTOR 3P
EH10	*1-564-517-41	PLUG, CONNECTOR 2P
EH11	*1-564-505-11	PLUG, CONNECTOR 2P
EH12	*1-564-505-31	PLUG, CONNECTOR 2P
EH13	*1-564-508-11	PLUG, CONNECTOR 5P
EH14	*1-564-506-11	PLUG, CONNECTOR 3P
EH15	*1-564-505-21	PLUG, CONNECTOR 2P
EH16	*1-564-505-11	PLUG, CONNECTOR 2P
EH20	*1-564-520-11	PLUG, CONNECTOR 5P
EH21	*1-564-518-11	PLUG, CONNECTOR 3P
EH22	*1-564-520-11	PLUG, CONNECTOR 5P
EH23	*1-564-520-11	PLUG, CONNECTOR 5P
EH24	*1-564-520-11	PLUG, CONNECTOR 5P
EH25	*1-564-520-11	PLUG, CONNECTOR 5P
EH26	*1-564-506-11	PLUG, CONNECTOR 3P
EH30	*1-564-505-41	PLUG, CONNECTOR 2P
EH31	*1-564-508-11	PLUG, CONNECTOR 5P
EH32	*1-564-506-11	PLUG, CONNECTOR 3P
F801	*1-532-272-XX	(US,Canadian)...FUSE 5A
F801	*1-532-286-00	(G-AEP,AEP,UK,E)...FUSE, TIME-LAG T2.5A
F802	*1-532-286-00	(G-AEP,AEP,UK,E)...FUSE, TIME-LAG T2.5A
IC401	8-759-111-68	IC UPC1237HA
IC901	8-759-923-90	IC BA4560
L101	1-413-101-00	(G-AEP)...COIL, INPUT
L102	1-413-101-00	(G-AEP)...COIL, INPUT
L151	1-413-101-00	(G-AEP)...COIL, INPUT
L152	1-413-101-00	(G-AEP)...COIL, INPUT
L601	*1-420-872-00	COIL, AIR CORE
L651	*1-420-872-00	COIL, AIR CORE
PT901	*1-448-909-11	(US,Canadian)...TRANSFORMER, POWER
PT901	*1-448-911-11	(E)...TRANSFORMER, POWER
PT901	*1-448-936-11	(G-AEP,AEP,UK)...TRANSFORMER, POWER
Q201	8-729-117-54	TRANSISTOR 2SA1175
Q202	8-729-117-54	TRANSISTOR 2SA1175
Q203	8-729-600-27	TRANSISTOR 2SC634SP
Q204	8-729-600-27	TRANSISTOR 2SC634SP
Q401	8-729-203-21	TRANSISTOR 2SK389-GR
Q402	8-729-600-27	TRANSISTOR 2SC634SP

## ELECTRICAL PARTS

Ref.No.	Part No.	Description
Q403	8-729-600-27	TRANSISTOR 2SC634SP
Q404	8-729-699-51	TRANSISTOR 2SA995
Q405	8-729-173-37	TRANSISTOR 2SA733-P
Q406	8-729-104-91	TRANSISTOR 2SA1383
Q408	8-729-104-18	TRANSISTOR 2SC3514
Q409	8-729-104-18	TRANSISTOR 2SC3514
Q411	8-729-141-42	TRANSISTOR 2SD414-R
Q412	8-729-104-18	TRANSISTOR 2SC3514
Q413	8-729-104-91	TRANSISTOR 2SA1383
Q414	8-729-127-53	TRANSISTOR 2SC2275-P
Q415	8-729-118-53	TRANSISTOR 2SA985-P
Q416	8-729-303-88	TRANSISTOR 2SC3856
Q417	8-729-303-85	TRANSISTOR 2SA1492
Q420	8-729-108-14	TRANSISTOR 2SA988-F
Q451	8-729-203-21	TRANSISTOR 2SK389-GR
Q452	8-729-600-27	TRANSISTOR 2SC634SP
Q453	8-729-600-27	TRANSISTOR 2SC634SP
Q454	8-729-699-51	TRANSISTOR 2SA995
Q455	8-729-173-37	TRANSISTOR 2SA733-A
Q456	8-729-104-91	TRANSISTOR 2SA1383
Q458	8-729-104-18	TRANSISTOR 2SC3514
Q459	8-729-104-18	TRANSISTOR 2SC3514
Q461	8-729-141-42	TRANSISTOR 2SD414-R
Q462	8-729-104-18	TRANSISTOR 2SC3514
Q463	8-729-104-91	TRANSISTOR 2SA1383
Q464	8-729-127-53	TRANSISTOR 2SC2275-P
Q465	8-729-118-53	TRANSISTOR 2SA985-P
Q466	8-729-303-88	TRANSISTOR 2SC3856
Q467	8-729-303-85	TRANSISTOR 2SA1492
Q470	8-729-108-14	TRANSISTOR 2SA988-F
Q901	8-729-354-52	TRANSISTOR 2SC2545-E
Q902	8-729-354-52	TRANSISTOR 2SC2545-E
Q907	8-729-194-57	TRANSISTOR 2SC945-P
Q909	8-729-173-37	TRANSISTOR 2SA733-P
Q951	8-729-354-52	TRANSISTOR 2SC2545-E
Q952	8-729-354-52	TRANSISTOR 2SC2545-E
R101	1-246-545-00	CARBON 1M 5% 1/4W
R102	1-246-545-00	CARBON 1M 5% 1/4W
R103	1-246-545-00	CARBON 1M 5% 1/4W
R105	1-246-545-00	CARBON 1M 5% 1/4W
R106	1-246-545-00	CARBON 1M 5% 1/4W
R107	1-246-545-00	CARBON 1M 5% 1/4W
R108	1-247-713-11	CARBON 1K 5% 1/4W
R109	1-247-713-11	CARBON 1K 5% 1/4W
R110	1-246-545-00	CARBON 1M 5% 1/4W
R111	1-244-877-00	(G-AEP,AEP,UK,E) ...CARBON 1.5K 5% 1/2W
R111	1-247-243-00	(US,Canadian)...CARBON 1.3K 5% 1/2W
R112	1-244-877-00	(G-AEP,AEP,UK,E) ...CARBON 1.5K 5% 1/2W
R112	1-247-243-00	(US,Canadian)...CARBON 1.3K 5% 1/2W
R113	1-244-877-00	(G-AEP,AEP,UK,E) ...CARBON 1.5K 5% 1/2W
R113	1-247-243-00	(US,Canadian)...CARBON 1.3K 5% 1/2W
R114	1-244-877-00	(G-AEP,AEP,UK,E) ...CARBON 1.5K 5% 1/2W
R114	1-247-243-00	(US,Canadian)...CARBON 1.3K 5% 1/2W

The components identified by shading and mark  $\Delta$  are critical for safety. Replace only with part number specified.

Les composants identifiés par une trame et une marque  $\Delta$  sont critiques pour la sécurité. Ne les remplacer que par une pièce portant le numéro spécifié.

## ELECTRICAL PARTS

Ref.No.	Part No.	Description			
R115	1-247-713-11	(G-AEP)...CARBON	1K	5%	1/4W
R116	1-247-713-11	(G-AEP)...CARBON	1K	5%	1/4W
R117	1-247-713-11	(G-AEP)...CARBON	1K	5%	1/4W
R118	1-247-713-11	(G-AEP)...CARBON	1K	5%	1/4W
R119	1-247-713-11	(G-AEP)...CARBON	1K	5%	1/4W
R120	1-247-713-11	(G-AEP)...CARBON	1K	5%	1/4W
R121	1-247-713-11	(G-AEP)...CARBON	1K	5%	1/4W
R122	1-247-713-11	(G-AEP)...CARBON	1K	5%	1/4W
R151	1-246-545-00	CARBON	1M	5%	1/4W
R152	1-246-545-00	CARBON	1M	5%	1/4W
R153	1-246-545-00	CARBON	1M	5%	1/4W
R155	1-246-545-00	CARBON	1M	5%	1/4W
R156	1-246-545-00	CARBON	1M	5%	1/4W
R157	1-246-545-00	CARBON	1M	5%	1/4W
R158	1-247-713-11	CARBON	1K	5%	1/4W
R159	1-247-713-11	CARBON	1K	5%	1/4W
R160	1-246-545-00	CARBON	1M	5%	1/4W
R165	1-247-713-11	(G-AEP)...CARBON	1K	5%	1/4W
R166	1-247-713-11	(G-AEP)...CARBON	1K	5%	1/4W
R167	1-247-713-11	(G-AEP)...CARBON	1K	5%	1/4W
R168	1-247-713-11	(G-AEP)...CARBON	1K	5%	1/4W
R169	1-247-713-11	(G-AEP)...CARBON	1K	5%	1/4W
R170	1-247-713-11	(G-AEP)...CARBON	1K	5%	1/4W
R171	1-247-713-11	(G-AEP)...CARBON	1K	5%	1/4W
R172	1-247-713-11	(G-AEP)...CARBON	1K	5%	1/4W
R201	1-247-739-11	CARBON	100		1/2W
R204	1-249-465-11	CARBON	47K	5%	1/4W
R205	1-249-465-11	CARBON	47K	5%	1/4W
R206	1-249-460-11	CARBON	15K	5%	1/4W
R207	1-247-721-11	CARBON	4.7K	5%	1/4W
R208	1-249-456-11	CARBON	5.6	5%	1/4W
R209	1-247-749-11	CARBON	560	5%	1/2W
R210	1-247-114-00	CARBON	200	5%	1/4W
R211	1-247-114-00	CARBON	200	5%	1/4W
R212	1-247-706-11	CARBON	330	5%	1/4W
R213	1-247-243-00	CARBON	1.3K	5%	1/2W
R214	1-247-243-00	CARBON	1.3K	5%	1/2W
R215	1-247-243-00	CARBON	1.3K	5%	1/2W
R216	1-247-243-00	CARBON	1.3K	5%	1/2W
R217	1-249-462-11	CARBON	22K	5%	1/4W
R218	1-249-462-11	CARBON	22K	5%	1/4W
R219	1-249-462-11	CARBON	22K	5%	1/4W
R220	1-247-713-11	CARBON	1K	5%	1/4W
R251	1-247-739-11	CARBON	100		1/2W
R254	1-249-465-11	CARBON	47K	5%	1/4W
R255	1-249-465-11	CARBON	47K	5%	1/4W
R270	1-247-713-11	CARBON	1K	5%	1/4W
R301	1-247-722-11	CARBON	5.6K	5%	1/4W
R302	1-247-717-11	CARBON	2.2K	5%	1/4W
R303	1-249-466-11	CARBON	56K	5%	1/4W
R304	1-247-725-11	CARBON	10K	5%	1/4W
R305	1-244-877-00	(G-AEP,AEP,UK,E) ...CARBON	1.5K	5%	1/2W
R305	1-247-243-00	(US,Canadian)...CARBON	1.3K	5%	1/2W
R306	1-244-877-00	(G-AEP,AEP,UK,E) ...CARBON	1.5K	5%	1/2W
R306	1-247-243-00	(US,Canadian)...CARBON	1.3K	5%	1/2W

## ELECTRICAL PARTS

Ref.No.	Part No.	Description			
R307	1-244-877-00	(G-AEP,AEP,UK,E) ...CARBON	1.5K	5%	1/2W
R307	1-247-243-00	(US,Canadian)...CARBON	1.3K	5%	1/2W
R308	1-244-877-00	(G-AEP,AEP,UK,E) ...CARBON	1.5K	5%	1/2W
R308	1-247-243-00	(US,Canadian)...CARBON	1.3K	5%	1/2W
R351	1-247-722-11	CARBON	5.6K	5%	1/4W
R352	1-247-717-11	CARBON	2.2K	5%	1/4W
R353	1-249-466-11	CARBON	56K	5%	1/4W
R354	1-247-725-11	CARBON	10K	5%	1/4W
R402	1-247-713-11	CARBON	1K		1/4W
R405	1-247-717-11	CARBON	2.2K	5%	1/4W
R406	1-247-704-11	CARBON	220	5%	1/4W
R407	1-247-700-11	CARBON	100		1/4W
R408	1-247-704-11	CARBON	220		1/4W
R409	1-247-704-11	CARBON	220		1/4W
R410	1-246-545-00	CARBON	1M	5%	1/4W
R412	1-217-399-00	FUSIBLE	33	5%	1/4W F
R413	1-249-490-11	CARBON	27K	5%	1/2W
R416	1-247-740-11	CARBON	120		1/2W
R417	1-249-705-11	CARBON	22K		1/2W
R419	1-202-727-00	CARBON	4.7M	5%	1/3W
R420	1-247-715-11	CARBON	1.5K	5%	1/4W
R421	1-247-721-11	CARBON	4.7K	5%	1/4W
R422	1-217-399-00	FUSIBLE	100	5%	1/4W F
R424	1-247-718-11	CARBON	2.7K	5%	1/4W
R425	1-247-126-00	CARBON	620	5%	1/4W
R426	1-217-454-00	FUSIBLE	470	5%	1/2W F
R427	1-217-434-00	FUSIBLE	10	5%	1/2W F
R428	1-217-434-00	FUSIBLE	10	5%	1/2W F
R429	1-217-446-00	FUSIBLE	100	5%	1/2W F
R430	1-217-434-00	FUSIBLE	10	5%	1/2W F
R431	1-217-434-00	FUSIBLE	10	5%	1/2W F
R432	1-217-611-00	RES, METAL PLATE 0.1			
R433	1-217-611-00	RES, METAL PLATE 0.1			
R436	1-247-715-11	CARBON	1.5K	5%	1/4W F
R437	1-249-460-11	CARBON	15K	5%	1/4W
R439	1-249-485-11	CARBON	8.2	5%	1/2W
R442	1-246-533-00	CARBON	330K	5%	1/4W
R443	1-247-725-11	CARBON	10K	5%	1/4W
R444	1-246-529-00	CARBON	220K	5%	1/4W
R445	1-249-461-11	CARBON	18K	5%	1/4W
R446	1-246-530-00	CARBON	240K	5%	1/4W
R447	1-206-662-00	(US,Canadian)...METAL OXIDE	100	5%	2W F
R447	1-206-663-00	(G-AEP,AEP,UK,E)...METAL OXIDE	100	5%	2W F
R452	1-247-713-11	CARBON	1K		1/4W
R455	1-247-717-11	CARBON	2.2K	5%	1/4W
R456	1-247-704-11	CARBON	220	5%	1/4W
R457	1-247-700-11	CARBON	100		1/4W
R458	1-247-704-11	CARBON	220		1/4W
R459	1-247-704-11	CARBON	220		1/4W
R460	1-246-545-00	CARBON	1M	5%	1/4W
R462	1-217-399-00	FUSIBLE	33	5%	1/4W F
R463	1-249-490-11	CARBON	27K	5%	1/2W
R466	1-247-740-11	CARBON	120		1/2W

The components identified by shading and mark  $\Delta$  are critical for safety. Replace only with part number specified.

Les composants identifiés par une trame et une marque  $\Delta$  sont critiques pour la sécurité. Ne les remplacer que par une pièce portant le numéro spécifié.



# TA-F22ESX/F500ES

## ELECTRICAL PARTS

Ref.No.	Part No.	Description			
R467	1-249-705-11	CARBON	22K		1/2W
R469	1-202-727-00	CARBON	4.7M	5%	1/3W
R470	1-247-715-11	CARBON	1.5K	5%	1/4W
R471	1-247-721-11	CARBON	4.7K	5%	1/4W
R472	1-217-399-00	FUSIBLE	100	5%	1/4W F
R474	1-247-718-11	CARBON	2.7K	5%	1/4W
R475	1-247-126-00	CARBON	620	5%	1/4W
R476	1-217-454-00	FUSIBLE	470	5%	1/2W F
R477	1-217-434-00	FUSIBLE	10	5%	1/2W F
R478	1-217-434-00	FUSIBLE	10	5%	1/2W F
R479	1-217-446-00	FUSIBLE	100	5%	1/2W F
R480	1-217-434-00	FUSIBLE	10	5%	1/2W F
R481	1-217-434-00	FUSIBLE	10	5%	1/2W F
R482	1-217-611-00	RES, METAL PLATE	0.1		
R483	1-217-611-00	RES, METAL PLATE	0.1		
R486	1-247-715-11	CARBON	1.5K	5%	1/4W F
R487	1-249-460-11	CARBON	15K	5%	1/4W
R489	1-249-485-11	CARBON	8.2	5%	1/2W
R492	1-246-533-00	CARBON	330K	5%	1/4W
R501	1-247-694-11	CARBON	33	5%	1/4W F
R502	1-249-487-11	CARBON	15K	5%	1/2W F
R601	1-247-727-11	(G-AEP)...CARBON	10	5%	1/2W
R602	1-247-727-11	(G-AEP)...CARBON	10	5%	1/2W
R651	1-247-727-11	CARBON	10	5%	1/2W
R652	1-247-727-11	(G-AEP)...CARBON	10	5%	1/2W
R701	1-247-749-11	CARBON	560	5%	1/2W
R751	1-247-749-11	CARBON	560	5%	1/2W
R901	1-247-700-11	(G-AEP)...CARBON	100	5%	1/4W
R901	1-247-706-11	(AEP,UK,E,US,Canadian) ...CARBON	330	5%	1/4W
R902	1-249-469-11	CARBON	100K	5%	1/4W
R903	1-247-700-11	CARBON	100	5%	1/4W
R904	1-249-469-11	CARBON	100K	5%	1/4W
R905	1-247-700-11	CARBON	100	5%	1/4W
R906	1-247-713-11	CARBON	1K	5%	1/4W
R907	1-247-713-11	CARBON	1K	5%	1/4W
R908	1-247-725-11	CARBON	10K	5%	1/4W
R909	1-247-138-00	CARBON	2K	5%	1/4W
R910	1-249-484-11	CARBON	6.8	5%	1/2W
R911	1-247-739-11	CARBON	100	5%	1/2W
R912	1-214-937-00	CARBON	1M	5%	1/2W
R913	1-249-844-11	CARBON	56K	1%	1/2W
R914	1-249-818-11	CARBON	4.7K	1%	1/2W
R915	1-247-704-11	CARBON	220	5%	1/4W
R922	1-247-721-11	CARBON	4.7K	5%	1/4W
R923	1-247-721-11	CARBON	4.7K	5%	1/4W
R924	1-206-670-00	(US,Canadian) METAL OXIDE	1.8K	5%	2W F
R924	1-215-894-11	(G-AEP,AEP,UK,E) METAL OXIDE	2.2K	5%	2W F
R926	1-215-894-11	(US,Canadian) METAL OXIDE	2.2K	5%	2W F
R926	1-216-459-00	(G-AEP,AEP,UK,E) METAL OXIDE	2.7K	5%	2W F
R951	1-247-700-11	(G-AEP)...CARBON	100	5%	1/4W
R951	1-247-706-11	(AEP,UK,E,US,Canadian) ...CARBON	330	5%	1/4W

The components identified by shading and mark  $\Delta$  are critical for safety. Replace only with part number specified.

Les composants identifiés par une trame et une marque  $\Delta$  sont critiques pour la sécurité. Ne les remplacer que par une pièce portant le numéro spécifié.

## ELECTRICAL PARTS

Ref.No.	Part No.	Description			
R952	1-249-469-11	CARBON	100K	5%	1/4W
R953	1-247-700-11	CARBON	100	5%	1/4W
R954	1-249-469-11	CARBON	100K	5%	1/4W
R955	1-247-700-11	CARBON	100	5%	1/4W
R956	1-247-713-11	CARBON	1K	5%	1/4W
R957	1-247-713-11	CARBON	1K	5%	1/4W
R958	1-247-725-11	CARBON	10K	5%	1/4W
R960	1-249-484-11	CARBON	6.8	5%	1/2W
R961	1-247-739-11	CARBON	100	5%	1/2W
R962	1-214-937-00	CARBON	1M	5%	1/2W
R963	1-249-844-11	CARBON	56K	1%	1/2W
R964	1-249-818-11	CARBON	4.7K	1%	1/2W
R965	1-247-704-11	CARBON	220	5%	1/4W
RT402	1-224-248-XX	RES, ADJ, SOLID	470		
RT452	1-224-248-XX	RES, ADJ, SOLID	470		
RY101	1-515-495-00	RELAY			
RY201	1-515-495-00	RELAY			
RY601	1-515-501-00	RELAY			
S201	1-570-893-11	SWITCH, ROTARY SLIDE (INPUT SELECTOR)			
S202	1-570-890-11	SWITCH, ROTARY SLIDE (INPUT SELECTOR)			
S203	1-570-892-11	SWITCH, ROTARY SLIDE (AUDIO REC OUT SELECTOR)			
S205	1-570-896-11	SWITCH, PUSH (2 KEY)(TONE CONTROL)			
S206	1-570-895-11	SWITCH, PUSH (1 KEY)(SOURCE DIRECT)			
S301	1-570-889-11	SWITCH, ROTARY (ADAPTOR)			
S601	1-570-897-11	SWITCH, SLIDE (REMOTE)(SPEAKER)			
S801	1-554-880-11	(G-AEP,AEP,UK)...SWITCH, PUSH (AC POWER)(1 KEY)			
S801	1-554-920-11	(E,US,Canadian)...SWITCH, PUSH (AC POWER)			
S901	1-554-019-00	SWITCH, SLIDE (REMOTE TYPE)(CARTRIDGE)			
TH501	1-806-882-11	(AEP,US,Canadian) ...THERMISTOR (POSITIVE)			
TH502	1-806-882-11	(AEP,US,Canadian) ...THERMISTOR (POSITIVE)			
TM601	1-536-767-21	TERMINAL BOARD, SPEAKER			
TM602	1-536-767-21	TERMINAL BOARD, SPEAKER			
TP401	*1-535-139-00	BASE POST 19MM (10MM PITCH) 2P			
TP451	*1-535-139-00	BASE POST 19MM (10MM PITCH) 2P			
VR201	1-237-473-11	RES, VAR, CARBON 150K/150K			
VR202	1-237-472-11	RES, VAR, CARBON 120K/120K			
VR301	1-237-471-11	RES, VAR, CARBON 250K/250K			
VR302	1-237-470-11	RES, VAR, CARBON 1M/1M/500K/500K			
V51	1-526-576-31	(E)...SELECTOR, POWER VOLTAGE			

## ACCESSORY & PACKING MATERIAL

Part No.	Description
2-297-403-00	SHEET (LARGE), PROTECTION
3-701-630-00	BAG, POLYETHYLENE
3-703-710-41	STICKER, SONY SYMBOL (12)
3-765-757-11	MANUAL, INSTRUCTION (ENGLISH,FRENCH, SPANISH,GERMAN,DUTCH,SWEDISH)
4-908-877-01	CUSHION
4-916-768-01	(G-AEP,AEP,UK,US,Canadian) ....INDIVIDUAL CARTON
4-916-768-11	(E).....INDIVIDUAL CARTON

## **TROUBLE CHECKS**

Should any problem persist after you have made these checks, consult your nearest Sony dealer.  
Before going through the check list below, first refer back to the connection and operating procedures.

<b>NO AUDIO</b>	
Faulty connection	Connect the audio system correctly.
The SPEAKERS selector is set to OFF.	Set the selector to the appropriate position.
The INPUT SELECTOR is not correctly set.	Set it correctly.
The ADAPTOR switch is set to ON when the ADAPTOR jacks are not used.	Set the ADAPTOR switch to OFF.
The equipment connected to the ADAPTOR jack is not turned ON.	Set the ADAPTOR switch to OFF or turn on the connected equipment.

<b>NO AUDIO FROM ONE CHANNEL OR UNBALANCED LEFT AND RIGHT SOUND LEVEL</b>	
Incorrect setting of the BALANCE control	Adjust it correctly.
One end of the speaker cords or connecting cords is removed.	Connect the cords correctly.

<b>NO AUDIO AND THE POWER/STANDBY INDICATOR LIGHTS IN RED</b>	
Short circuit of speaker cords	Check the speaker cords.
The amplifier is too heat.	Install the amplifier in good air circulation.

<b>LACK OF BASS SOUND OR OBSCURE INSTRUMENT POSITION</b>	
Mal-setting of sound quality controls	Adjust the controls for sound quality.
Faulty setting of the CARTRIDGE LOAD selector	Set it correctly.
Improper phasing of speaker connection	Connect the speakers for proper phasing.

<b>DISTORTED SOUND</b>	
Improper input signal	Check the equipment being played. For details, refer to the instruction manual of each equipment.
Input capacity of speakers is excessively small.	Lower the sound level.

<b>SEVERE HUM OR NOISE</b>	
Noise from TV unit, etc.	Keep the connecting cords away from transformers or motors, TV unit and fluorescent lights.
Faulty connection of turntable system	Ground the turntable system.