

UNI^{VAL}®



GENERAL DESCRIPTION

Breaking capacity	1000 A
Voltage rating	32 V
Ambient temp. + overheating	-40 °C to +125 °C
Body material	See table below
Blade material	Zinc
Blade coating	See table below
Compliant with	ISO 8820-3 (type C) REACH, RoHS

RATINGS

Size [A]	Color coding	UNI ^{VAL} with window		Transparent UNI ^{VAL} without window		Expected voltage drop [mV]	ISO cable size [mm ²]	I ² t* [A ² s]
		Body material	Blade coating	Body material	Blade coating			
1	Black	PBT-GF20	Raw			< 250	0.35	TBD
2	Grey	PBT-GF20	Raw or tin plated			142	0.35	157
3	Violet	PBT-GF20	Raw	PC	Raw	135	0.35	200
4	Pink	PBT-GF20	Raw or tin plated	PC	Raw	126	0.35	205
5	Beige	PBT-GF20	Raw or tin plated	PC	Raw	119	0.5	218
7.5	Brown	PBT-GF20	Raw or tin plated	PC	Raw	139	0.75	304
10	Red	PBT-GF20	Raw or tin plated	PC	Raw	112	1.0	320
15	Blue	PBT-GF20	Raw or tin plated	PC	Raw	104	1.5	480
20	Yellow	PBT-GF20	Raw or tin plated	PC	Raw	117	2.5	720
25	Natural	PBT-GF20	Raw or tin plated	PSU	Raw	104	2.5	1155
30	Green	PBT-GF20	Raw or tin plated	PSU	Raw	103	4.0	1843
40	Orange	PBT-GF20	Raw or tin plated			101	6.0	2880

*Calculated from breaking capacity test.

OVERALL DIMENSIONS

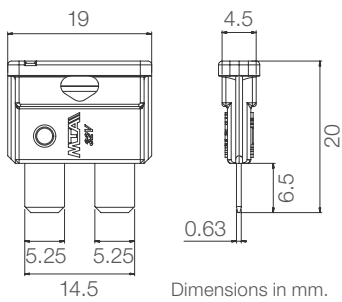

MELTING TIME AND CURVE

Operating time limits:

% IR	Min [s]	Max [s]
110	360000	∞
135	0.75	600
160	0.25	50
200	0.15	5
350	0.04	0.5
600	0.02	0.1

Melting time graph at 23°C on test module ISO.

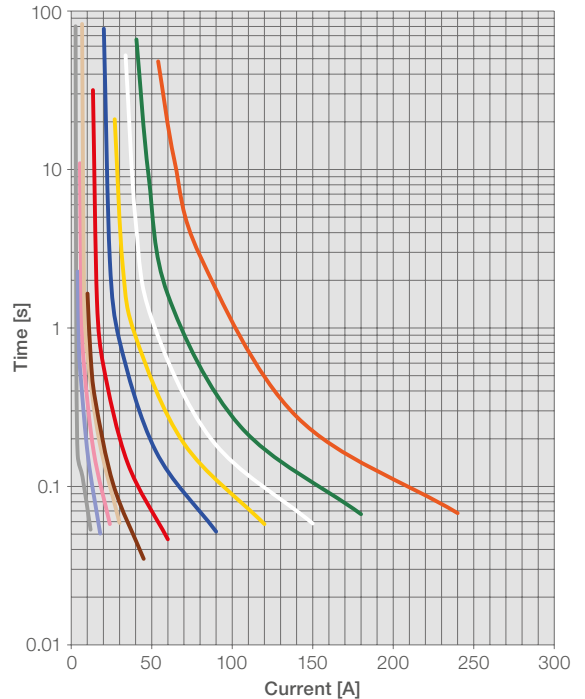

RERATING CURVE

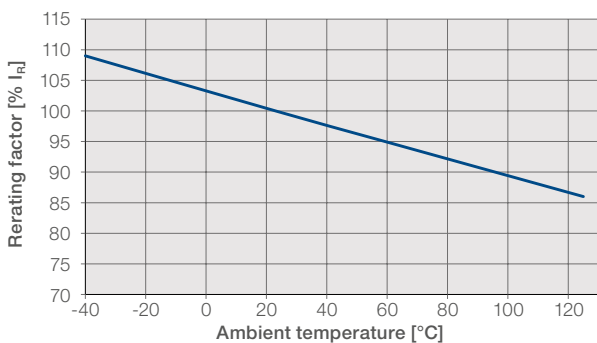

Products, information, drawings, specifications and reference numbers (hereafter "contents") discussed herein are for reference purposes only. All contents herein are provided on an "as is" basis, without warranties of any kind. The contents discussed herein remain the sole and exclusive property of MTA S.p.A. and shall not be copied, translated in whole or in part without MTA S.p.A. prior written consent. No license of any patent, copyright, mask work, trademark or any other intellectual property right is granted under this document, by implication, estoppel or otherwise. Contents may be modified and changed by MTA S.p.A. without any notice. For updates or additional information about MTA products, please contact your nearest MTA office. All brand names, trademarks and registered trademarks belong to their respective owners.