

Standard Products

ACT5101-1 Brushless DC Motor Drive

High Voltage 3-Phase

www.aeroflex.com/Power

March 29, 2006

FEATURES

- 500VDC Rating
- 50Amp DC Rating
- Package Size 3.0" x 2.1" x 0.39"
- 4 Quadrant Control
- 6 Step Trapezoidal Drive Capability
- Military Processing Available
- Isolated Upper and Lower Gate Drivers
- Temperature Range -55°C TO +125°C
- Designed for commercial, industrial and aerospace applications
- Aeroflex-Plainview is a Class H & K MIL-PRF-38534 manufacturer

DESCRIPTION

The Aeroflex-Plainview ACT5101-1 is a high voltage 3 phase brushless DC motor drive that combines a 500VDC, 50A high power output stage along with a low power digital input and gate drive stages. A digital lock-out feature protects the output stage from accidental cross-conduction thus preventing shoot-through conditions. The ACT5101-1 also includes a floating gate drive design for each upper and lower transistor. On-board gate drive supplies provide a continuous floating voltage for each upper and lower transistor, even during a motor stall.

The high power output stage rated at 500VDC, 50A is capable of delivering over 25KW to the load. This is accomplished through the use of high power IGBTs with ultra-fast recovery rectifiers in parallel.

The ACT5101-1 utilizes power hybrid technology to provide the highest levels of reliability and lightest weight while requiring the smallest amount of board space. The ACT5101-1 is available with military processing and operates over the -55 to +125°C temperature range.

This makes the ACT5101-1 ideal for all military, space, and commercial avionics applications. These include electro-hydrostatic actuators (EHA's) and electro-mechanical actuators (EMA's) for flight surface control, missile fin actuators, thrust vector control, electric brakes, fuel and cooling pumps. Additional applications include environmental conditioning blowers, radar positioning, solar panel positioning, and cryogenic cooler pumps. The ACT5101-1 is therefore especially suitable for use in applications for all military tank upgrades, helicopters, planes and new commercial avionics using 270VDC as the main power.



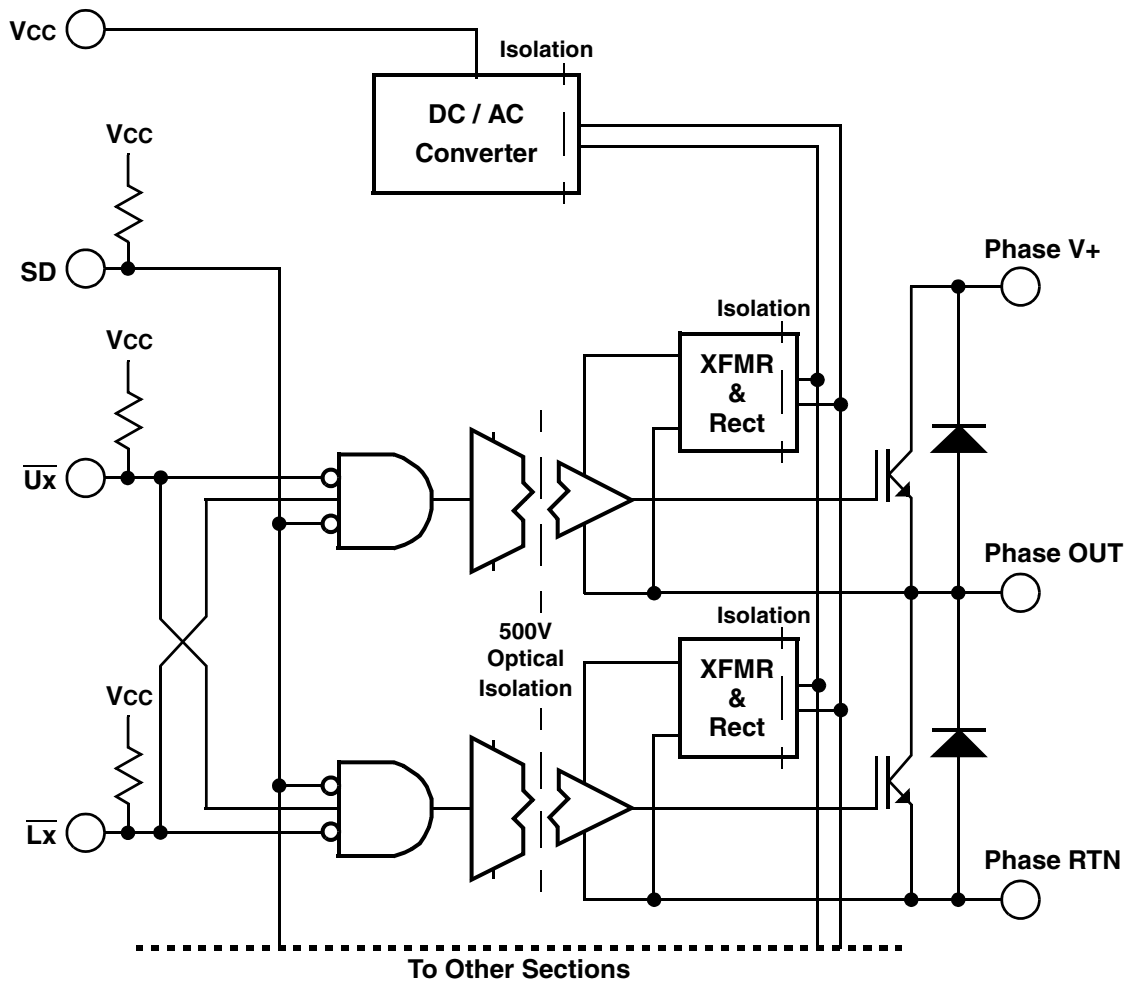

FIGURE 1 – BLOCK DIAGRAM

TABLE I – ABSOLUTE MAXIMUM RATINGS

PARAMETER	SYMBOL	RANGE	UNITS
Output Supply Voltage (Pins 3,7,11)	V+A, V+B, V+C	500 Max <u>1/</u>	VDC
Input Supply Voltage (Pin 12)	VCC	+18 Max	VDC
Output Current (Refer to Figure 2) Continuous Pulsed	IOF IOFP	50 Max <u>1/</u> 90 Max <u>2/</u>	A A
Junction-Case Thermal Resistance (IGBT) each transistor	θ_{JCIGBT}	.45 Max	°C/W
Junction-Case Thermal Resistance (DIODE) each Diode	$\theta_{JCDIODE}$.85 Max	°C/W
Maximum Lead Soldering Temp <u>3/</u>	Ts	250 Max	°C
Junction Temperature Range	TJ	-55 to 150	°C
Case Operating Temperature	T _C	-55 to 125	°C
Case Storage Temperature Range	TCS	-55 to 150	°C

Notes:

1/ Tc = +25°C.

2/ Pulse Width ≤ 10ms, Duty Cycle ≤ 10%. Guaranteed, not tested.

3/ Solder 1/8" from case for 5 seconds maximum.

TABLE II – NORMAL OPERATING CONDITIONS

Tc = +25°C unless otherwise specified

PARAMETERS	SYMBOL	TEST CONDITIONS	MIN	TYP	MAX	UNIT
INPUT STAGE						
Input Supply Current	IS	Vcc = +15V	-	100	115	mA
Input Supply Voltage	VCC	-	14.25	15	15.75	VDC
Input Voltage Low	VINL	NOTE: Internally pulled up to Vcc = +15V	-	-	4	VDC
Input Voltage High	VINH		11.0	-	-	VDC
Input Current Low	IINH		-	-	3.75	mA
POWER OUTPUT STAGE						
Output Current Continuous (Refer to Figure 2) <u>3/</u>	IOF	-	-	-	50	A
Output Supply Voltage	V+ A, V+ B, V+ C	-	15	270	500	VDC
Output Voltage Drop (Each IGBT) NOTE: $V_{DROP_F} = V_{PHASE V^+} - V_{PHASE Out}$ or $V_{DROP_F} = V_{PHASE Out} - V_{PHASE RTN}$	V_{DROP_F} <u>3/</u> V_{DROP_F}	IOF = 40A IOF = 6.5A	- -	2.2 -	2.5 1.85	VDC VDC
Instantaneous Forward Voltage (Flyback Diode) NOTE: $V_{DROP_R} = V_{PHASE Out} - V_{PHASE V^+}$ or $V_{DROP_R} = V_{PHASE RTN} - V_{PHASE Out}$	V_{DROP_R} <u>1/</u> <u>3/</u> V_{DROP_R} <u>1/</u> <u>3/</u>	IOR = 40A IOR = 6.5A	- -	1.3 -	1.6 1.0	VDC VDC
Reverse Recovery Time (Flyback Diode) <u>3/</u>	tRR	-	-	-	35	nsec
Reverse Leakage Current (VIN High) Tc = 25°C <u>3/</u> Tc = 125°C <u>1/</u> <u>3/</u> <u>4/</u>	IR25 IR125	V+ = 500V V+ = 480V	- -	- -	500 8.0	µA mA

TABLE II – NORMAL OPERATING CONDITIONS (con't)

T_C = +25°C unless otherwise specified

PARAMETERS	SYMBOL	TEST CONDITIONS	MIN	TYP	MAX	UNIT
ISOLATION CHARACTERISTICS						
Isolation Voltage	Viso	-	500	-	-	V
SWITCHING CHARACTERISTICS 2/						
UPPER DRIVE (See Figure 3 – Timing Diagram):						
Turn-on propagation delay	t _d (on)	-	-	-	700	nsec
Turn-off propagation delay	t _d (off)	-	-	-	2	μsec
Shut-down propagation delay	t _{SDU}	-	-	-	3.5	μsec
Turn-on Transition Time	t _r	-	-	-	250	nsec
Turn-off Transition Time	t _f	-	-	-	250	nsec
LOWER DRIVE (See Figure 3 – Timing Diagram): 2/						
Turn-on propagation delay	t _d (on)	-	-	-	700	nsec
Turn-off propagation delay	t _d (off)	-	-	-	2	μsec
Shut-down propagation delay	t _{SDL}	-	-	-	3.5	μsec
Turn-on Transition Time	t _r	-	-	-	250	nsec
Turn-off Transition Time	t _f	-	-	-	250	nsec
SWITCHING ENERGY LOSSES (At I_{OF} = 40A, V = 270V) 3/						
Turn-on Energy	E _{On}	T _C = +125°C	-	-	0.5	mJ
Turn-off Energy	E _{Off}		-	-	3.0	mJ
DEAD TIME (See Digital Input Stage Description herein)	t _{dt}	-	500	-	-	nsec

Notes:

1/ Pulse width ≤ 300usec duty cycle ≤ 2%.

2/ Tested @ 6.5Amps.

3/ Guaranteed, not tested.

4/ Not to exceed T_J of +150°C. See Mechanical Applications for Case Interface Temperature Description herein.

DIGITAL INPUT STAGE

The ACT5101-1 offers complete flexibility by allowing the user to turn on/off each of the 6 IGBTs in any order or combination desired which enables the hybrid to be commutated in a 6 step trapezoidal mode. The only unacceptable combination would be to turn on an upper and lower transistor of the same phase. This is not a desirable condition for normal operation and is therefore not allowed. The ACT5101-1 has a digital lockout feature that prevents turn-on of two in-line transistors. Damage to one or both of the transistors would occur if this protection circuitry was not present in the hybrid. As a safety precaution, it is still recommended that a 500nsec dead time be installed between commands at the inputs of the upper and lower transistors of the same phase. This will compensate for any lag in transistor turn-off due to the inductive load.

The SD input allows the user to enable/disable the drive stage of the ACT5101-1 on demand. This input can be incorporated into the user's temperature or current monitoring circuitry to shutdown the hybrid if excessive current or case temperatures are sensed.

The digital input circuits are of the Schmitt trigger type with hysteresis, thus greatly enhancing the input noise immunity. The inputs are internally pulled up to 15 volts so that an uncommitted input is sensed as "OFF", providing a measure of protection against an accidental input disconnect.

GATE DRIVE

The ACT5101-1 includes a gate drive supply which provides a floating voltage for each upper and lower transistor. This constant voltage allows the motor to be operated at very low duty cycles or driven into a stall without any loss of upper or lower gate drive. This performance could not be obtained with only a conventional boot strap design.

POWER OUTPUT STAGE

IGBTs (insulated gate bipolar transistors) are technically similar to bipolars and MOSFETs. An IGBT is a composite of a transistor with an N-channel MOSFET connected to the base of a PNP transistor. Like the MOSFET, it offers high input impedance and requires low input drive current. IGBT conduction losses are low, as with bipolar technology, and IGBT voltage drops are much lower compared with those of MOSFETs. Consequently, the IGBT offers a high current density. With a smaller die size than the MOSFET, it can handle the same current rating. Unlike MOSFETs, IGBTs have no intrinsic body diode. The ACT5101-1 includes 35nsec fast recovery rectifiers in parallel across each of the 6 IGBTs to carry the reverse current when the IGBT is turned off.

It is important for the user to observe the Absolute Maximum ratings of the ACT5101-1 so that the voltage and current rating is not exceeded. If over-voltage/over-current protection is desired it must be implemented external to the ACT5101-1. Figure 2 shows the ACT5101-1 output current capability vs. case temperature.

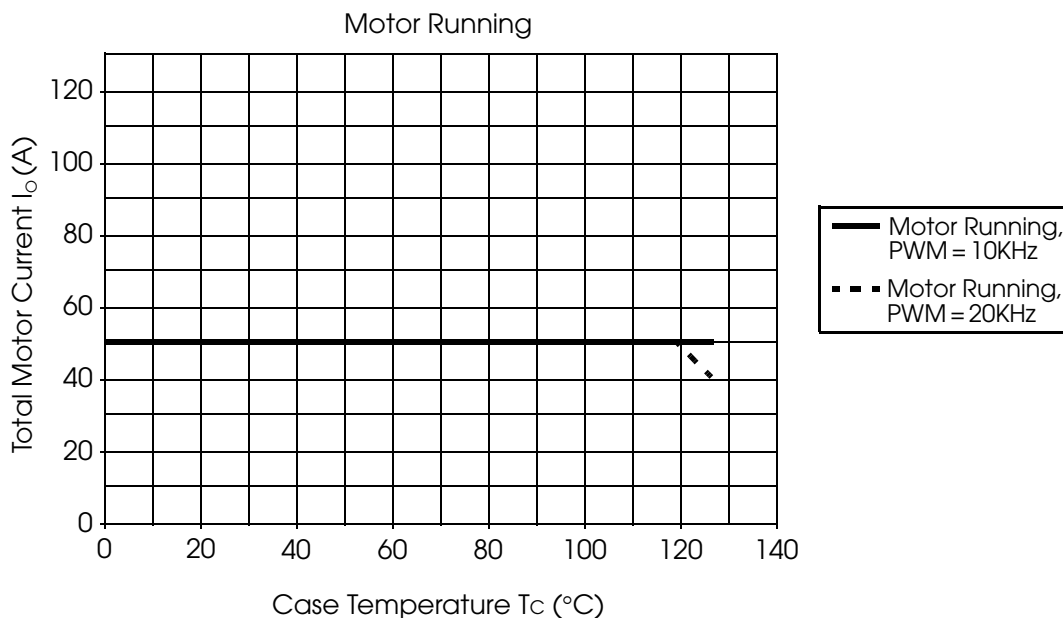

FIGURE 2A - OUTPUT CURRENT vs CASE TEMPERATURE – MOTOR RUNNING

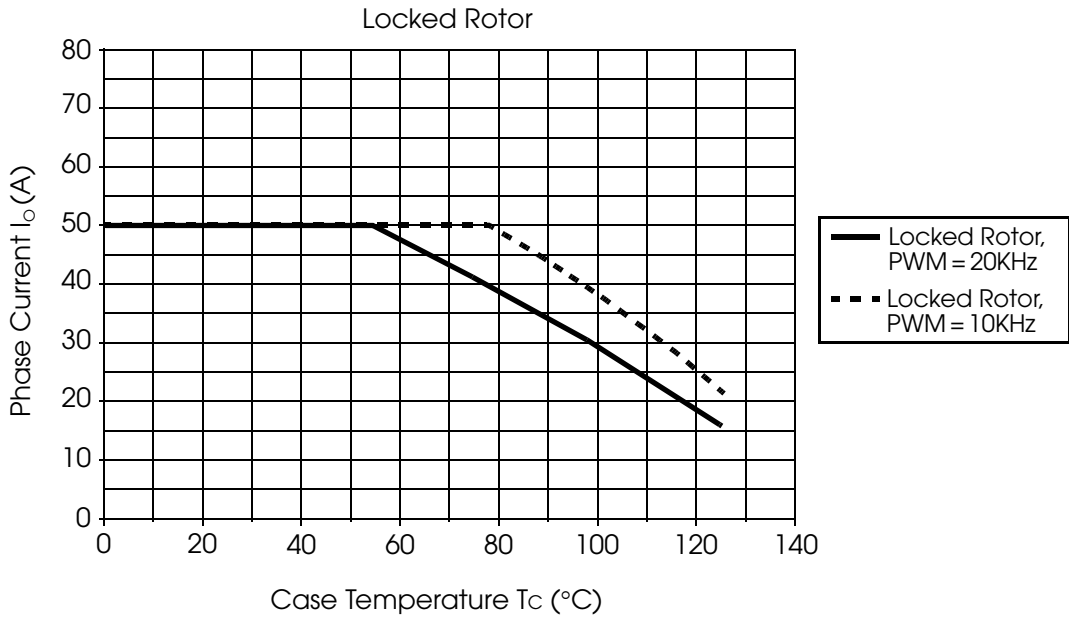

FIGURE 2B - OUTPUT CURRENT vs CASE TEMPERATURE – LOCKED ROTOR

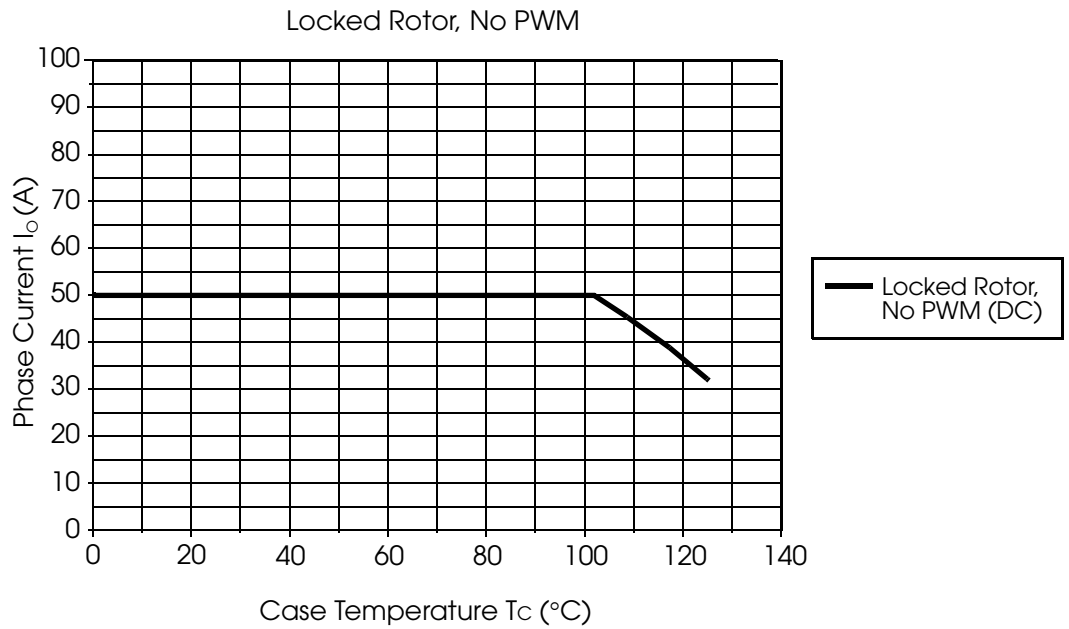

FIGURE 2C - OUTPUT CURRENT vs CASE TEMPERATURE – LOCKED ROTOR, NO PWM

MECHANICAL

The ACT5101-1 construction utilizes only the highest quality materials and manufacturing available to ensure a high reliability, robust power hybrid design. The case is selected for best thermal conductivity, hermeticity, and voltage/current carrying capability. The case is electrically isolated from the circuit and can withstand 1500VAC from pin to case, therefore no insulating pads or washers are required for mounting.

In order to remove the heat being generated from the ACT5101-1, it must be bolted down to the motor, a heat sink or the actual system chassis such as a missile structure or aircraft wing rib for example. Thermally conductive grease or a "Sil-pad" is recommended between the hybrid case baseplate and its mounting surface to fill in any surface imperfections and improve the heat transfer from case-to-heat sink. It is important to keep the temperature at this interface no greater than +125°C in order to maintain safe semi-conductor junction temperatures.

The leads of the ACT5101-1 can be formed upward, away from the baseplate, so that a PC board can be mounted directly above it. A wiring harness can also be hand-wired and soldered directly to the leads of the ACT5101-1 if this is preferred.

TABLE III – INPUT/OUTPUT TRUTH TABLE

INPUTS							OUTPUTS		
\overline{UA}	\overline{UB}	\overline{UC}	\overline{LA}	\overline{LB}	\overline{LC}	SD	PHASE A	PHASE B	PHASE C
1	1	0	1	0	1	0	Z	L	H
1	1	0	0	1	1	0	L	Z	H
1	1	0	0	0	1	0	L	L	H
1	0	1	1	1	0	0	Z	H	L
1	0	1	0	1	1	0	L	H	Z
1	0	1	0	1	0	0	L	H	L
1	0	0	0	1	1	0	L	H	H
1	0	0	0	1	0	0	L	H	Z
1	0	0	0	0	1	0	L	Z	H
0	1	1	1	1	0	0	H	Z	L
0	1	1	1	0	1	0	H	L	Z
0	1	1	1	0	0	0	H	L	L
0	1	0	1	0	1	0	H	L	H
0	1	0	1	0	0	0	H	L	Z
0	1	0	0	0	1	0	Z	L	H
0	0	1	1	1	0	0	H	H	L
0	0	1	1	0	0	0	H	Z	L
0	0	1	0	1	0	0	Z	H	L
1	1	1	1	1	1	0	Z	Z	Z
1	1	1	0	0	0	0	L	L	L
0	0	0	1	1	1	0	H	H	H
X	X	X	X	X	X	1	Z	Z	Z

H=high level, L=low level, X=irrelevant, Z=high impedance (off)

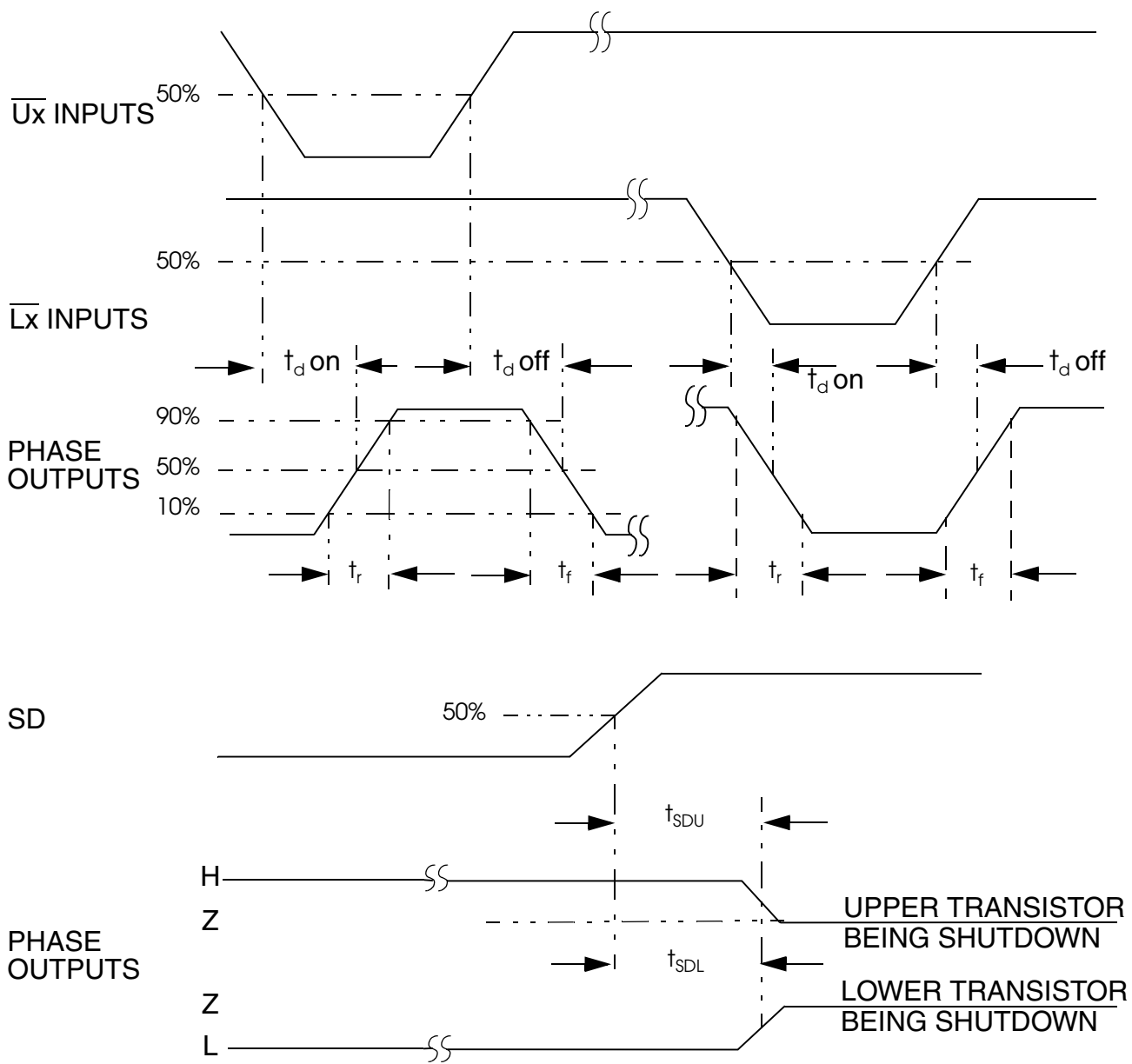

FIGURE 3 – TIMING DIAGRAM

TABLE IV – FUNCTION vs PIN NUMBERS /DESCRIPTION

FUNCTION	PIN #	DESCRIPTION
V+ A	11	High Voltage D.C. Bus, Phase A
V+ B	7	High Voltage D.C. Bus, Phase B
V+ C	3	High Voltage D.C. Bus, Phase C
VCC	12	+15VDC input required to power gate drive supply and gate drive circuitry of all three phases.
GND	19,22,26	Reference for LOGIC supply, +15V supply, and digital inputs.
RTN A	8	Return for High Voltage Bus, Phase A.
RTN B	5	Return for High Voltage Bus, Phase B
RTN C	1	Return for High Voltage Bus, Phase C
PHASE A	9	Output to motor winding Phase A
PHASE B	6	Output to motor winding Phase B
PHASE C	2	Output to motor winding Phase C
UA	18	Digital input to Phase A upper transistor
LA	17	Digital input to Phase A lower transistor
UB	21	Digital input to Phase B upper transistor
LB	20	Digital input to Phase B lower transistor
UC	25	Digital input to Phase C upper transistor
LC	24	Digital input to Phase C lower transistor
SD	23	Digital shut-down input to enable / disable all six gate drives
N/C	4,10,13-16	No connection Internally

TABLE V – PIN NUMBERS vs FUNCTION

PIN #	FUNCTION	PIN #	FUNCTION
1	RTN C	26	GND
2	PHASE C	25	UC
3	V+ C	24	LC
4	N/C	23	SD
5	RTN 4B	22	GND
6	PHASE B	21	UB
7	V+ B	20	LB
8	RTN A	19	GND
9	PHASE A	18	UA
10	N/C	17	LA
11	V+ A	16	N/C
12	Vcc	15	N/C
13	N/C	14	N/C

POWER PACKAGE OUTLINE

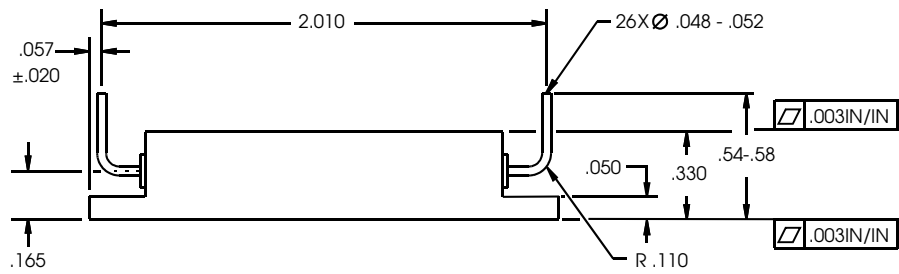
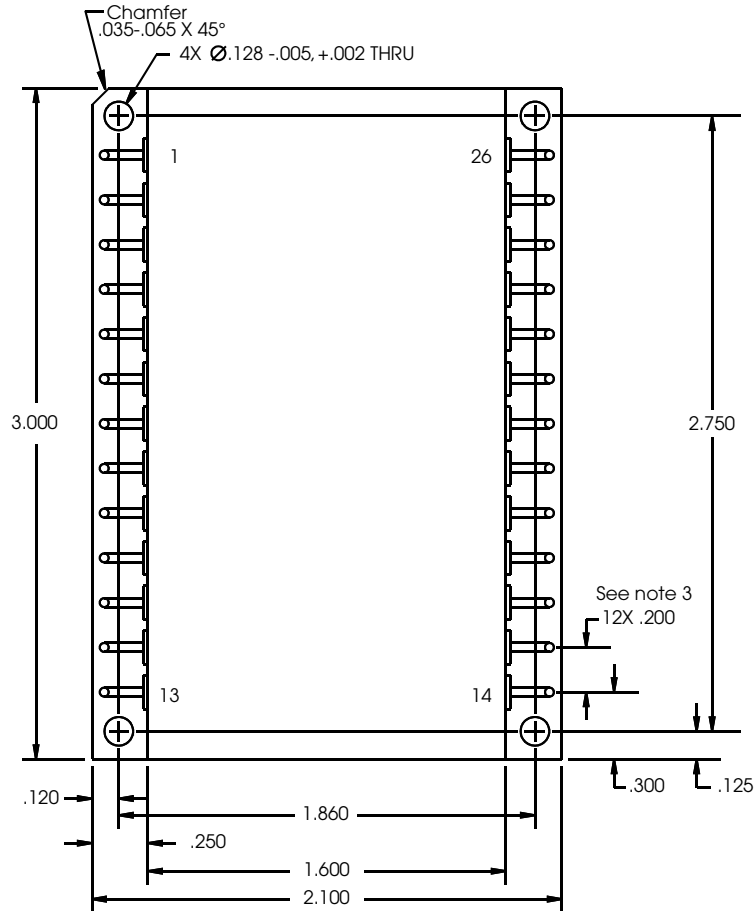

Notes:

1. Package contains BeO substrate.
2. Dimensions Tolerance: $\pm .005$, unless otherwise noted.
3. Pin Tolerance: non-cumulative

ORDERING INFORMATION

MODEL NUMBER	SCREENING
ACT5101-1	Operating Temperature Range -55°C to +125°C. Screened to the individual test methods of MIL-STD-883. Class H DSCC QML Pending.
ACT5101-1-7	Commercial Flow, 25°C testing only

PLAINVIEW, NEW YORK
Toll Free: 800-THE-1553
Fax: 516-694-6715

INTERNATIONAL
Tel: 805-778-9229
Fax: 805-778-1980

NORTHEAST
Tel: 603-888-3975
Fax: 603-888-4585

SE AND MID-ATLANTIC
Tel: 321-951-4164
Fax: 321-951-4254

WEST COAST
Tel: 949-362-2260
Fax: 949-362-2266

CENTRAL
Tel: 719-594-8017
Fax: 719-594-8468

www.aeroflex.com info-ams@aeroflex.com

Aeroflex Microelectronic Solutions reserves the right to change at any time without notice the specifications, design, function, or form of its products described herein. All parameters must be validated for each customer's application by engineering. No liability is assumed as a result of use of this product. No patent licenses are implied.



Our passion for performance is defined by three attributes represented by these three icons: solution-minded, performance-driven and customer-focused