

# Application Note AN-1035

## DirectFET<sup>®</sup> Technology Board Mounting Application Note

### Table of Contents

Device construction .....	2
Design considerations .....	3
Assembly considerations.....	4
Mechanical test results.....	10
Appendix A.1 ST-outline.....	16
Appendix A.2 SQ-outline .....	17
Appendix A.3 SJ-outline .....	18
Appendix A.4 SH-outline .....	19
Appendix A.5 S1-outline.....	20
Appendix A.6 S2-outline.....	21
Appendix A.7 SA-outline .....	22
Appendix A.8 SB-outline .....	23
Appendix A.9 SC-outline .....	24
Appendix A.10 S3C-outline .....	25
Appendix A.11 MT-outline.....	26
Appendix A.12 MX-outline.....	27
Appendix A.13 MP-outline.....	28
Appendix A.14 MQ-outline .....	29
Appendix A.15 MN-outline.....	30
Appendix A.16 MZ-outline .....	31
Appendix A.17 MU-outline.....	32
Appendix A.18 M2-outline .....	33
Appendix A.19 M4-outline .....	34
Appendix A.20 MA-outline.....	35
Appendix A.21 MB-outline.....	36
Appendix A.22 MC-outline.....	37
Appendix A.23 MD-outline.....	38
Appendix A.24 ME-outline.....	39
Appendix A.25 MF-outline.....	40
Appendix A.26 L4-outline .....	41
Appendix A.27 L6-outline .....	42
Appendix A.28 L8-outline .....	43
Appendix A.26 LA-outline.....	44

The growing DirectFET range includes various can sizes and device outlines. There are now lead-free variants, identified by a PbF suffix after the part number (for example, IRF6618PbF). The main text of this application note contains guidance applicable to the whole range, including lead-free devices. Then, in Appendix A, there are device outlines, substrate layouts and stencil designs for each device (common to both standard and lead-free variants). For more details about individual devices, refer to the relevant product data sheet and package outline drawing. To simplify board mounting and improve reliability, International Rectifier manufactures DirectFET devices to exacting standards. These high standards have evolved through evaluating many different materials and designs. Although such evaluations have yielded good results, the recommendations in this application note may need to be adjusted to suit specific production environments.

## Introduction

DirectFET<sup>®</sup> is a surface mount semiconductor technology designed primarily for board-mounted power applications. It eliminates unnecessary elements of packaging that contribute to higher inductance and resistance, both thermal and electrical, so that its power capabilities exceed those of comparably sized packages.

The growing DirectFET range includes various can sizes and device outlines. There are 'plus' variants that use thinner dies to improve electrical performance and efficiency. There are PbF variants, pre-soldered with a tin-silver-copper alloy (Sn96.5 Ag3.0 Cu0.5) to improve performance with lead-free pastes and identified by a PbF suffix after the part number (for example, IRF6618PbF). There are also variants qualified for the automotive industry, which have a gate marker of **AU** instead of ●.

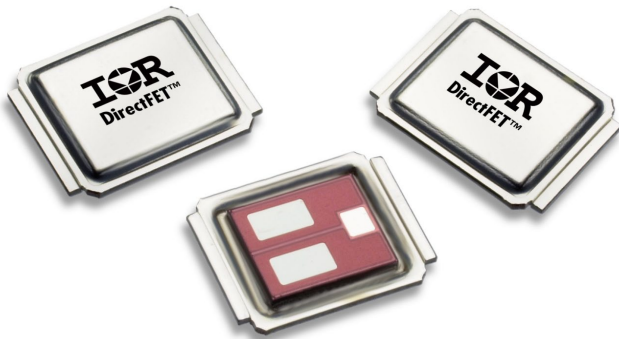

The main text of this application note contains guidance applicable to the whole range, including lead-free devices. Then, in Appendix A, there are device outlines, substrate layouts and stencil designs for each device (common to both standard and lead-free variants). For more details about individual devices, refer to the relevant product data sheet and package outline drawing.

To simplify board mounting and improve reliability, International Rectifier manufactures DirectFET devices to exacting standards. These high standards have evolved through evaluating many different materials and designs. Although such evaluations have yielded good results, the recommendations in this application note may need to be adjusted to suit specific production environments.

## Device construction

DirectFET devices use an innovative construction technique to make source and gate connections directly to the die surface (Figure 1). The remainder of the surface is coated with passivation to protect it and to control the position, shape and size of the solder contacts between device and substrate.

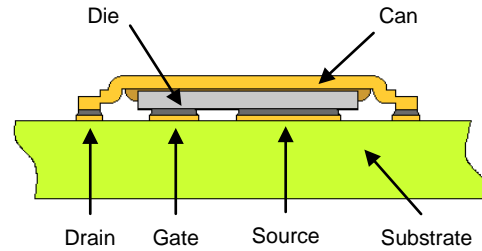
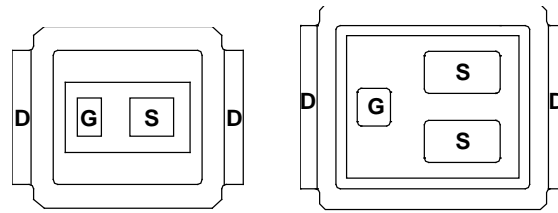

Figure 1 Sectional view

The drain connection is formed by a plated copper can, which is bonded to the drain side of the silicon die. The can has two contact areas, both of which must be soldered to the substrate although one can be used solely as a mechanical anchor. Using tracks of similar size under both drain contacts will help to ensure that the device does not tilt during reflowing.

Figure 2 shows typical contact configurations of DirectFET devices, covering most devices in the range. Specific pad assignments are shown in the data sheet for each product.



G – Gate, S – Source, D – Drain  
 (viewed from underside of device)

Figure 2 DirectFET contact configuration

Figure 3 shows how DirectFET devices are labeled. The part number, batch number and date code are provided to support product traceability. The last digit of the batch number on PbF variants is underlined.

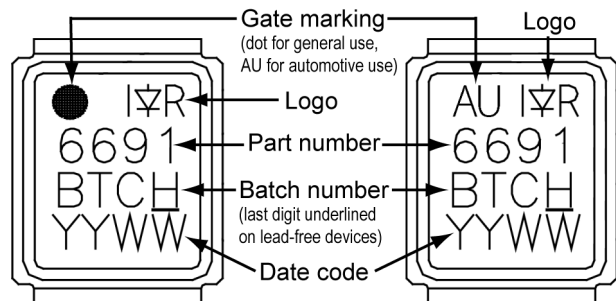

Figure 3 Device markings

Note: The dot (or AU on automotive devices) shows at which end of the device the gate pad is located. **It is not Pin 1**. Figure 4 shows recommended pad numbering schemes.

## Design considerations

### Substrates

DirectFET technology was originally developed and evaluated for use with epoxy and polyimide glass-woven substrates. The test substrates were finished in electroless nickel immersion gold but any of the numerous surface finishes available are suitable. Subsequent evaluations have confirmed that DirectFET devices can be used with insulated metal substrates made from aluminum silicon carbide (AlSiC) and copper (Cu). For more information, refer to the DirectFET Technology Materials and Practices Application Note (AN-1050), available at:

[www.irf.com/technical-info/appnotes/an-1050.pdf](http://www.irf.com/technical-info/appnotes/an-1050.pdf)

The substrate finish can affect the amount of energy required to make solder joints; this can in turn be a factor in solder quality issues such as solder balling, tombstoning (or tilt) and the formation of voids. It is important to ensure that the appropriate reflow profile is used for the selected substrate finish.

### Substrate designs

To achieve low-loss track layouts, DirectFET devices were designed for use with solder-mask-defined layouts. Although the devices can be used with pad-defined (non-solder-mask-defined) layouts, these have not been evaluated. The outline of DirectFET devices and the use of solder-mask-defined pads contribute to efficient substrate design. Large-area tracks optimize electrical and thermal performance.

If pad numbering is required to produce a component outline within the library of a CAD system, International Rectifier recommends that the conventions shown in Figure 4 are adopted. This makes it easier to discuss any issues that may arise during design and assembly.

DirectFET devices can be placed in parallel using simple layouts (Figure 5). International Rectifier recommends a minimum separation of 0.500mm (0.020"). The separation can be adjusted to reflect local process capabilities but should allow for rework. Micro-screen design and desoldering tool type may affect how closely devices are placed to each other and to other components.

Refer to Appendix A for device outlines, substrate layouts and stencil designs for each can size and device outline in the DirectFET range. These are common to both standard and lead-free devices.

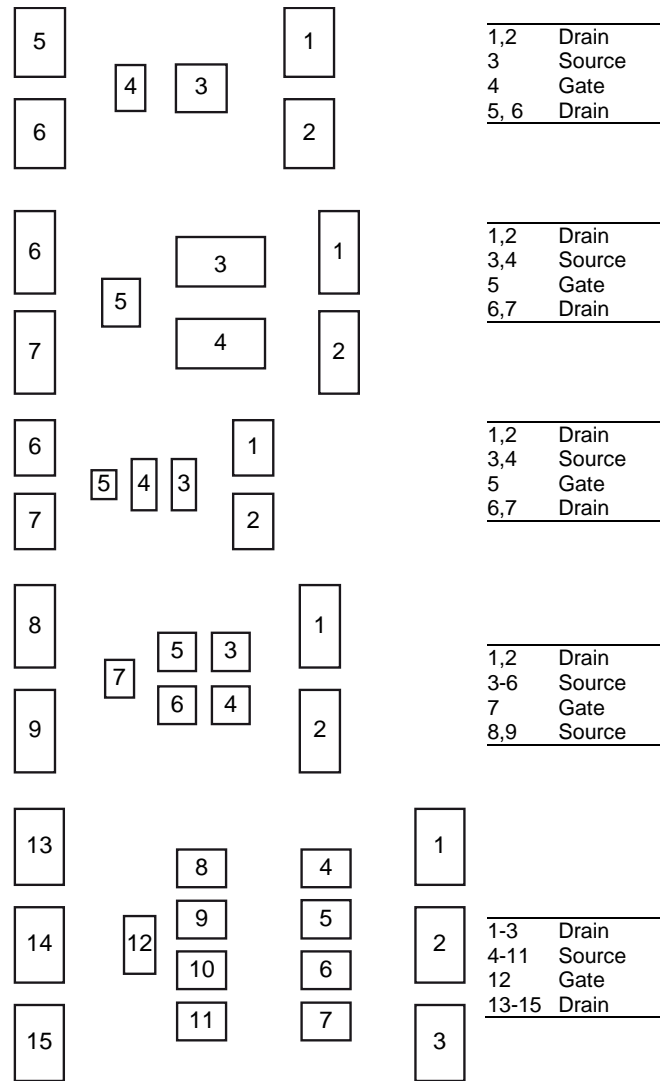

(viewed from top of substrate)

Figure 4 Recommended pad numbering

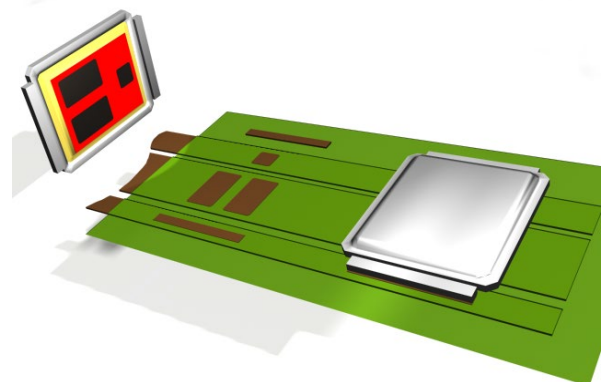

Figure 5 Placing DirectFET devices in parallel

**Standardized pad layouts**

Later devices in the DirectFET range use standardized pad outlines (Figure 6). This means that devices of the same can size can easily be interchanged and upgraded. For example, a substrate layout for a small can device with one source pad can be designed to accept a small can device with two source pads; the gate pads are in the same positions on the two devices and the first of two source pads is in the same position as the single source pad.

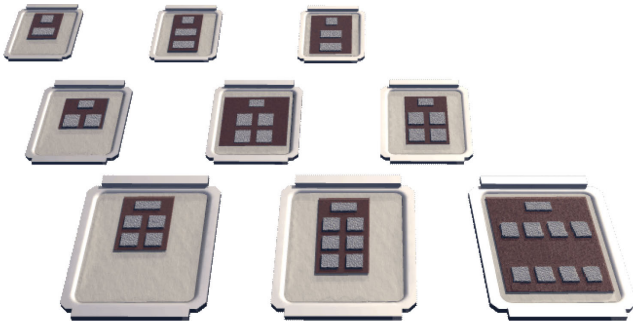

Figure 6 Standardized pad layouts

For many devices (see table below), it is possible to use either a device-specific or a universal pad outline on the substrate. The stencil design determines where solder paste is applied to a universal outline. To avoid wastage and flux residues, International Rectified recommends using a device-specific stencil design.

Device outline	Stencil design	Dedicated pad outline	Universal pad outline
S1	S1	S1	S2
S2	S2	S2	S2
SB	SB	SB	SB
M2	M2	M2	M4
M4	M4	M4	M4
L4	L4	L4	L10
L6	L6	L6	L10
L8	L8	L8	L10

Note: L10 is the universal pad layout for large-can devices (Figure 7). All other pad layouts are shown in Appendix A.

The device outline code indicates the can size and number of source pads (see table below).

Can size		Number of source pads
S	small	n – 1, 2, 4, 6, 8 or 10
M	medium	
L	large	

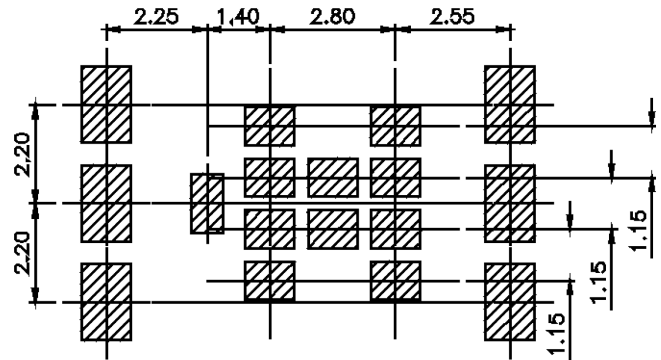

(dimensions in mm)

Figure 7(a) L10-outline substrate/PCB layout

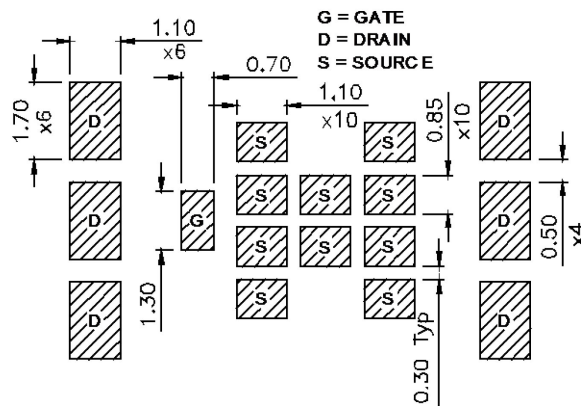

(dimensions in mm)

Figure 7(b) L10-outline substrate/PCB layout

**Assembly considerations**

International Rectifier designed DirectFET devices to be as easy as possible to assemble using standard surface mounting techniques. Recessing the die within the package (Figure 8) forces a standoff between die and substrate, which helps to reduce solder balling problems and improves device reliability. However, procedures and conditions can have a profound influence on assembly quality. It is therefore necessary to develop an effective process based on the individual requirements for the application.

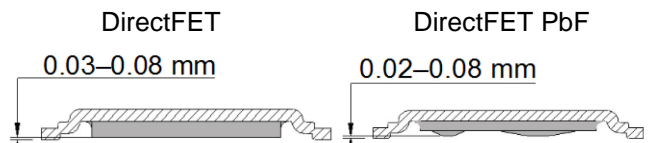
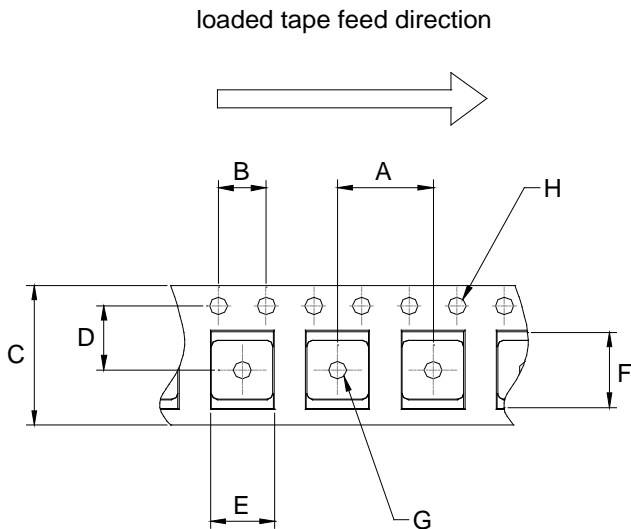

Figure 8 Contact planarity

**Packaging**

DirectFET devices are supplied in tape and reel format (Figure 9). The gate contact is furthest from the tape index holes.



Dimensions (mm)						
	Small can		Medium can		Large can	
Code	Min	Max	Min	Max	Min	Max
A	7.90	8.10	7.90	8.10	11.90	12.10
B	3.90	4.10	3.90	4.10	3.90	4.10
C	11.90	12.30	11.90	12.30	15.90	16.30
D	5.45	5.55	5.45	5.55	7.40	7.60
E	4.00	4.20	5.10	5.30	7.20	7.40
F	5.00	5.20	6.50	6.70	9.90	10.10
G	1.50	NC	1.50	NC	1.50	NC
H	1.50	1.60	1.50	1.60	1.50	1.60

Figure 9 Tape and reel packaging

**Storage requirements**

DirectFET devices are packed in sealed, nitrogen-purged, antistatic bags. Devices in unopened bags have a shelf life of two years. Devices may have a Moisture Sensitivity Level (MSL) of 1 or 3: this is shown on the bag label.

**Solder pastes**

International Rectifier evaluated different types of solder paste from various manufacturers. The properties of pastes vary from manufacturer to manufacturer, meaning that some perform better than others. In general, high slumping pastes tend to suffer more from solder balling than slump-resistant pastes; solder balling is discussed in the next section on stencil design. In addition, some pastes appear to be more prone to voiding than others.

Solder alloys, metal contents and flux constituents all influence the rheology of the solder paste. This in turn influences how the paste reacts during processing. DirectFET products with a PbF suffix have been evaluated using both lead-containing pastes (Sn63 Pb37) and lead-free pastes (Sn96.5 Ag3.0 Cu0.5). Products without the PbF suffix are not recommended for use with lead-free pastes.

Solder paste selection must take flux residues into consideration. Many customers use solder pastes that contain no-clean fluxes designed to be fully cured or 'caramelized' during the reflow process, forming an inert varnish-like residue that need not be washed off or removed. However, some solder pastes (marketed as 'probeable' or 'pin-testable') contain fluxes that remain soft or tacky for up to a month to enable underlying PCB pads to be electrically probed on an automated test system using pins or needle-type probes. Unfortunately, as the residues remain acidic and chemically active until they harden, they can cause electrical leakage and/or corrosion, especially in damp or moist environments. Therefore, International Rectifier recommends that assemblies using probeable or pin-testable solder pastes are not exposed to their intended operating environment or subjected to reliability testing that involves moisture testing for at least a month. Alternatively, such assemblies can be baked after electrical testing to cure the flux more quickly.

Evaluations of both standard and lead-free devices used reflow profiles that conform to IPC/JEDEC standard J-STD-020C (July 2004 revision.) All devices were reflowed three times to simulate the building of a double-sided PCB and provide for one rework process. However, International Rectifier advises customers to refer to the technical datasheet for their selected solder paste for initial guidance when setting up reflow profiles, before they carry out optimization exercises.



**Stencil design**

Stencil design is instrumental in controlling the quality of solder joints. Appendix A shows stencil designs that have given good results with recommended substrate outlines, both at International Rectifier and at customers' locations. They are based on reductions of 25% (equivalent to printing 75% of the PCB pad area).

The designs assume a stencil thickness of 0.150mm (0.006"); they should be revised for other thicknesses. DirectFET can be used with thicknesses of 0.100-0.250mm (0.004-0.010"). Stencils thinner than 0.100mm are unsuitable because they deposit insufficient solder paste to make good solder joints with the die; high reductions sometimes create similar problems. Stencils in the range of 0.125mm-0.200mm (0.005-0.008"), with suitable reductions, give the best results.

Post-reflow evaluations can help to assess how a stencil is performing within a given process. Two main problem areas can be addressed by improving stencil design:

- **Solder balling around the perimeter of the die.** This can be caused by too much solder paste, in which case the stencil might need to be reduced by more than 25%. The reduction can be symmetrical but biasing it unevenly may help to prevent solder balling; the stencil designs in Appendix A have apertures moved further from the die edge for this reason. Solder balling can result from other external factors, such as the moisture content of the board and incorrect ramp rates or insufficient soak times in the reflow profile. Leadless devices like DirectFET can sometime accentuate existing deficiencies within a process.
- **Misshapen joints.** If the joints are smaller or seem to be only partially made, this might suggest that there is insufficient solder to make the joint. If, however, the joints have what appear to be additional areas extending from their edges, they are usually the result of too much solder; this almost certainly the case if solder balls are also present. Insufficient solder can also cause voiding but this is more likely to arise from other factors, including surface finish, solder paste and substrate condition.

**Device placement**

Due to the recessed position of the die, DirectFET devices should ideally be depressed into the solder paste by at least 0.050mm (0.002") to ensure that the contact areas are in full contact with the paste. Placement machines operate on various principles, some based on over-travel and others on placement

pressure. Good results have been achieved using over-travel of 0.050mm-0.100mm (0.002-0.004") and placement pressure of 150-250g.

Insufficient placement pressure may result in poor solder joints or in devices being tilted and/or misaligned. Although it is better to avoid perceptible tilt, poor placement does not always cause reflow problems. Ideally, devices should be placed to an accuracy of 0.050mm on both X and Y axes but, during evaluations, devices centered themselves from placement inaccuracies of more than 0.200mm.

DirectFET<sup>®</sup> *plus* devices use thinner silicon dies than the standard range, and are fitted in thinner cans (height M in Figure 18). The correct device height must be used in placement programs. To determine the height of a device, refer to the product data sheet.



	Device height (mm)	
	Min	Max
DirectFET	0.590	0.700
DirectFET <sup>®</sup> <i>plus</i>	0.535	0.595

Figure 18 Height of standard and plus devices

Standard and plus devices can be used together, although height differences must be taken into account if heatsinks are fitted to the top of the devices.

**Heatsinks**

DirectFET devices are designed to deliver superior thermal performance compared with other packages. In many applications, heatsinks are not required but they may sometimes be applied to achieve even greater cooling in use.

For optimum ruggedness, International Rectifier recommends attaching heatsinks to the substrate using clips, screws or other fasteners (Figure 10). However, if limited board space prevents this, they may be attached to the top of devices (Figure 11). When heatsinks are attached to the top of devices without mechanical fastenings to the substrate, potential mechanical stresses on the heatsink must be considered. Such stresses will be transferred to the device and may cause mechanical damage and, in extreme cases, device failure.

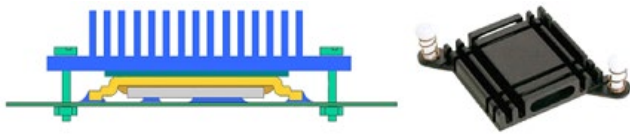

Figure 10 Heatsinks attached to substrates

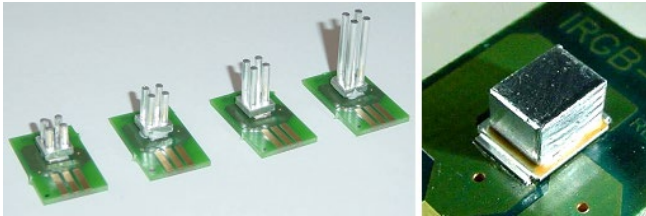

Figure 11 Heatsinks attached to devices

Whichever heatsink design and application method is used, heatsinks can be applied to single or multiple devices. Figure 12 shows multiple device heatsinking.



Figure 12 Heatsinks attached to multiple devices

When one heatsink covers multiple devices, problems can arise from variances in the thermal expansion of substrate, solder, device, thermal interface material (TIM) and heatsink. This is especially true when the heatsink is attached to the top of the devices without mechanical fastenings to the substrate. As well as normal operating conditions, calculations of thermal expansion must include other heat excursions applied to the assembly (for example, during reflow soldering).

TIMs should be used to improve thermal contact by filling air gaps (voids) between the mating faces of the device and the heatsink. Without a TIM (Figure 13), there is a significant proportion of voids over the area. With a TIM (Figure 14), there is full contact.

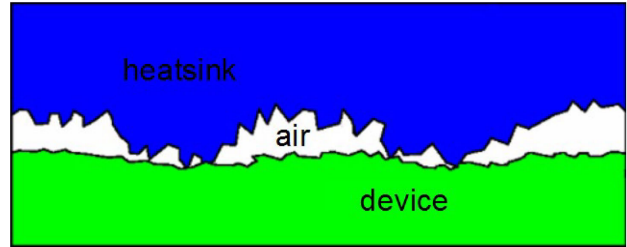

Figure 13 Thermal contact (no TIM)  $K \approx 0.024 \text{ W}/(\text{m} \cdot \text{K})$

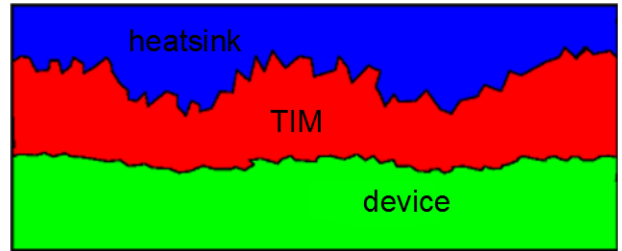

Figure 14 Thermal contact (TIM)  $K \approx 0.5\text{--}10.0 \text{ W}/(\text{m} \cdot \text{K})$

Many TIMs are available in various forms. The table below summarizes the advantages and disadvantages of each form, although individual examples may differ. The suitability of each form depends on the design and use of the assembly. Evaluations will be needed to establish the most suitable material for an application.

When applying a TIM to the device-heatsink joint, it is important to consider the material and the way it is applied. If a fluid or flowable material is used, it must not be allowed to seal the sides of the device that are not in contact with the substrate. Such seals can trap air under the device, both around the die and between the device and substrate. If the assembly is then subjected to heating for any reason (whether in normal operation, further processing or burn-in testing), the trapped air will expand and may break either the device-die bond or the device-substrate joints. Although tests have shown that this generally happens only when a large heat excursion is applied to a large DirectFET body containing a small silicon die, it is still worthy of consideration.

Type	Description	Advantages	Disadvantages
Grease	Traditional form, filled with conductive particles of Al <sub>2</sub> O <sub>3</sub> , BeO, Al or Ag Thermal conductivity: 0.3–2.0 W/(m·K) (up to 6 W/(m·K) for Al) Vendors: Shinetsu, Bergquist	Good surface conformance Good surface wetting Thin bonds (<0.005")	Difficult to pre-apply Messy processing Can leak out over time Needs controlled dispensation No electrical isolation
Gel	Grease replacement, cross-links in curing to form a gel-like substance Thermal conductivity: 0.3–2.0 W/(m·K) Vendors: Thermoset (Lord MG series)	Good surface conformance Good surface wetting Thin bonds (<0.005") Does not leak out over time	Cannot be pre-applied Needs curing (can be from burn-in) Messy processing Needs controlled dispensation No electrical isolation
Adhesive	Heat-cured and filled with conductive particles similar to grease Thermal conductivity: 0.3–1.3 W/(m·K) Vendors: Dow Corning, 3M	Good surface conformance Good surface wetting Thin bonds (<0.005") Mechanical attachment	Cannot be pre-applied Needs curing (can be from burn-in) Messy processing Needs controlled dispensation No electrical isolation
Tape	Pressure-sensitive and adhesive-filled, with conductive particles on a fibreglass or plastic carrier Thermal conductivity: 0.7–1.5 W/(m·K) Vendors: Bergquist, Dow Corning, 3M	Moderate surface wetting Mechanical attachment Can be die-cut and pre-applied Clean and simple processing Electrical isolation	Poor surface conformance Thick bonds
Phase change	Waxy material, changes to a gel at about 50°C Thermal conductivity: 0.8–1.5 W/(m·K) Vendors: Bergquist, Dow Corning, 3M	Good surface conformance for irregularities < 0.002" Good surface wetting Clean processing Can be pre-applied or on a carrier Thin bonds (<0.005") (if pre-applied) Electrical isolation (if on carrier)	Poor surface conformance for large irregularities and bowing
Pads	Thickness: 0.010–0.250" Thermal conductivity: 0.8–4.0 W/(m·K) Vendors: Bergquist, Dow Corning, 3M	Good surface conformance for large irregularities Simple to use Can be reused Can be die-cut and pre-applied Clean processing	Poor surface conformance for small irregularities Poor wetting Thick bonds Pressure required to fit pads can make them difficult to use effectively

If excess TIM is applied, this can flow under the DirectFET device. Thermal expansion can then break the device-substrate joints. In Figure 15, a heatsink has been removed with floss to show that excess heatsink adhesive has spread across the substrate. It has covered the devices and sealed their sides.



Figure 15 Excess heatsink adhesive covering devices

In Figure 16, a cross-section reveals that the adhesive has flowed under the DirectFET devices. It has filled the gap between substrate, die and device body.

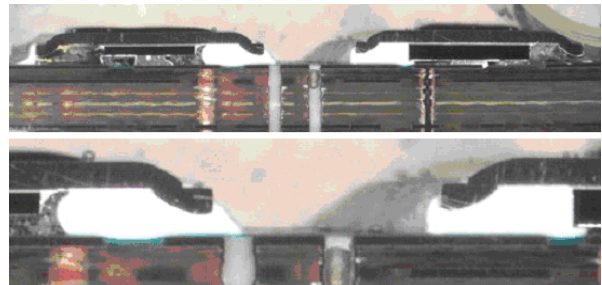

Figure 16 Heatsink adhesive under devices



In Figure 17, the TIM has expanded and separated the silicon die from the device body.

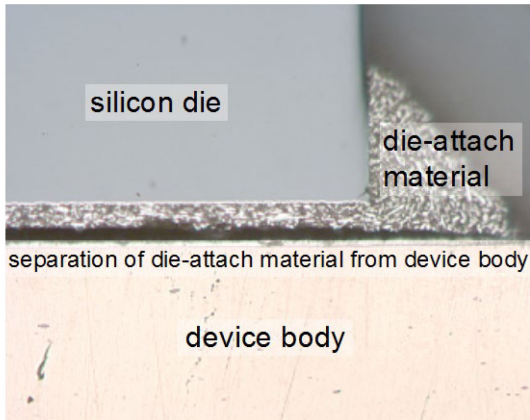

Figure 17 Die separated from device body

With so many heatsink designs and materials, proposed combinations must be fully evaluated to establish their suitability for a planned application.

**Reflow equipment**

DirectFET devices are suitable for assembly using surface mount technology reflowing equipment and are recommended for use with convection, vapor phase and infrared equipment. PbF qualified devices have a good resistance to short-term exposure to high temperatures, making them suitable for reflow profiles of up to 260°C (measured by attaching a thermocouple to a DirectFET device).

There are no special requirements for successful assembly but all reflow processes used in evaluation and qualification complied with the recommendations of solder paste suppliers. Using incorrect reflow profiles can cause solder quality issues such as solder balling, tombstoning (or tilt) and the formation of voids; if such problems arise, the reflow profile should be checked.

The DirectFET package is designed to have superior thermal resistance properties. For this reason, it is essential that the core of the substrate reaches thermal equilibrium during the pre-heating stage of the reflow profile to ensure that adequate thermal energy reaches the solder joint. For more information, visit [www.irf.com/product-info/directfet/dfmanuengineer.html](http://www.irf.com/product-info/directfet/dfmanuengineer.html).

**Inspection**

For comprehensive information on inspecting board-mounted DirectFET devices, refer to the DirectFET Inspection Application Note (AN-1080), available at:

[www.irf.com/technical-info/appnotes/an-1080.pdf](http://www.irf.com/technical-info/appnotes/an-1080.pdf)

As with all chip scale packaging (including land grid arrays and ball grid arrays), the best way to inspect devices after reflow is by taking X-ray images. The images for DirectFET and DirectFET PbF devices will differ slightly, as shown in Figure 19.

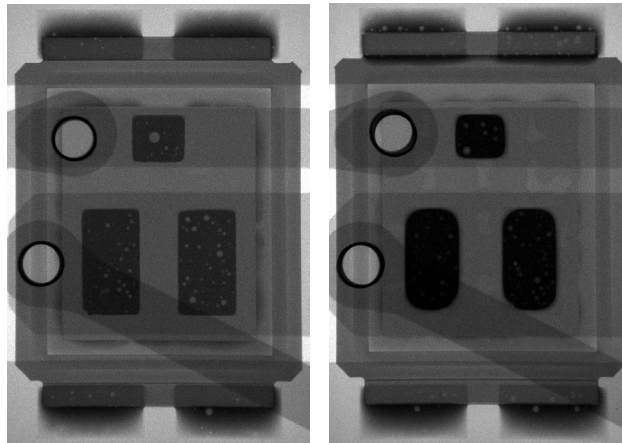

Figure 19 X-rays of DirectFET (left) and DirectFET PbF

An X-ray image of a board-mounted DirectFET PbF device shows denser solder joints, with fewer voids and solder balls, but also with poorer edge definition than seen in DirectFET devices processed under the same conditions. The reason for this is that the solder joints are significantly thicker for the DirectFET PbF devices, which are pre-soldered. As solder tends to adhere more readily to pre-soldered surfaces, the solder joints on the lead-free devices have a more pronounced hour-glass shape. In an X-ray image, this results in blurring of the joint edges and rounding of the joint corners.

### Rework guidelines

Modern rework stations for ball grid array and leadless packages often use two heating stages. The first heats the substrate, either with a conventional hot-plate or a hot-air system. The second stage uses a hot-air system for localized heating, often with the option of unheated air for faster cooling of the solder interconnections on the replaced device; this improves the solder grain structure.

The device placement mechanism or arm usually has a hot-air de-soldering gun as part of the pick head, equipped with a vacuum cup and thermocouple. Once the solder reflow temperature has been reached, the vacuum is automatically engaged to allow the device to be removed from the substrate. This reduces the risk of causing damage by premature removal.

International Rectifier does not recommend reusing devices removed from a substrate. Dispose of the old device and use a new replacement.

To replace a DirectFET device:

Note: If you usually bake to remove residual moisture before rework, insert your normal procedure here.

1. Heat the site to approximately 100°C (150°C for lead-free assembly) using the substrate heating stage.

Note: Pb devices are qualified for a maximum reflow peak temperature of 230°C (260°C for PbF devices). To avoid overheating the device or substrate, adjust the settings on your equipment to achieve a maximum air temperature of 300°C.

2. Lower the placement arm to bring the de-soldering tool into contact with the device. When the device and the solder interconnects reach reflow temperature, lift the placement arm to remove the device from the substrate. Discard the device.
3. Clear residual solder from the site using a blade-type de-soldering tool and de-soldering braid. Clear residual flux using a flux-reducing agent. Take care in cleaning the site: damage to the solder-resist may produce undesirable results.
4. When the site is ready, apply new solder paste with a micro-stencil and squeegee.
5. Position a new device on the vacuum tip of the placement head and lower the placement arm until the device is in contact with the solder paste.
6. Switch off the vacuum on the placement head and retract the placement arm, leaving the device in place.

7. Heat the site to approximately 100°C (150°C for lead-free assembly) using the substrate heating stage.
8. Use the de-soldering tool to heat both device and solder interconnects to reflow temperature, waiting until all the solder has reflowed.
9. Retract the arm, leaving the device in place. Cool as quickly as possible.

### Mechanical test results

International Rectifier has subjected board-mounted DirectFET devices to extensive mechanical tests, conducted in accordance with industry standards and practices. The devices tested were of medium can size, one MQ-outline and one MT-outline. Given that all DirectFET devices are made in the same way, other can sizes should perform to the same high standard.

This section contains summarized results for bend tests, compression tests, drop tests and vibration tests. Full reports are available on request.

#### Bend tests

##### Method

These tests were carried out in accordance with BS EN 60068-2-21:1999 Test U: Robustness of terminations and integral mounting devices.

- To gauge relative performance, DirectFET devices were tested against ceramic capacitors of a similar size.
- Substrates were initially tested over knife edges set at 90mm pitch but, as few devices failed, the pitch was changed to 70mm. This meant that the same deflection formed a more acute radius, increasing the strain and reducing the deflection needed to cause failure (13-14mm deflection over 70mm pitch causes approximately the same strain as 25mm deflection over 90mm pitch).
- The speed of deflection was 1mm s<sup>-1</sup> for all tests.
- The test board measured 100x40mm and was manufactured from FR4 2oz copper, finished in nickel gold. The solder used was Sn63 Pb37.
- Devices were mounted both longitudinally and transversely, and were tested with the devices mounted on both front and back of the board.

**Results**

Figures 20 and 21 show the deflection required to cause failure in MQ-outline and MT-outline medium can devices.

Note: The shaded areas indicate the point at which the substrates failed. No components survived beyond this.

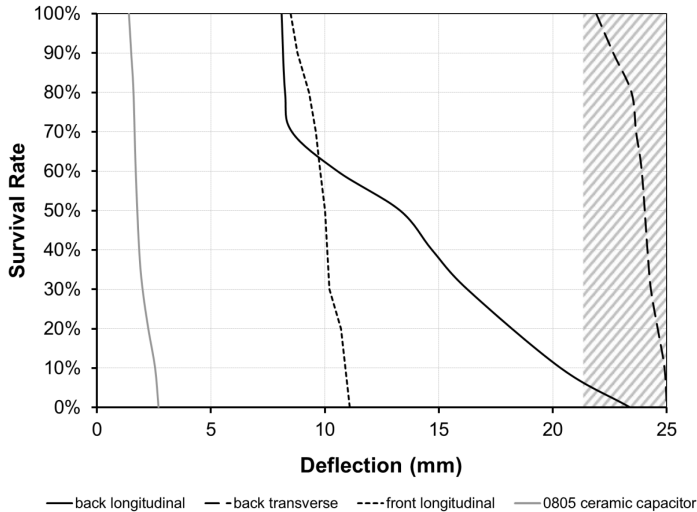

Figure 20 MQ-outline deflection test results

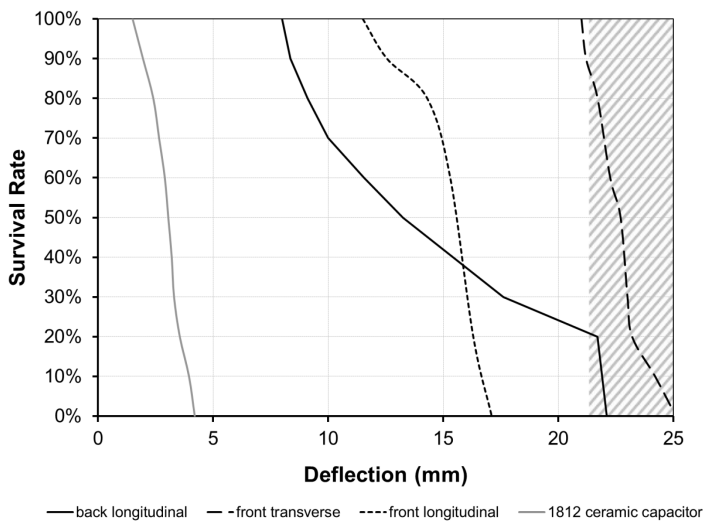

Figure 21 MT-outline deflection test results

**Compression tests**

*Method*

- Tests were carried out at ambient room temperature (22°C).
- Test speed was:  
0.5mmmin<sup>-1</sup> for the MQ- and MT-outlines  
1.2mmmin<sup>-1</sup> for the L8-outline  
(return speed of 20mmmin<sup>-1</sup> where applicable).
- Test duration was measured from the point at which the tester registered a force of:  
0.05N for the MQ- and MT-outlines  
1.00N for the L8-outline.
- The test was terminated if the force reached:  
1750N for the MQ- and MT-outlines  
2000N for the L8-outline.

Continuous pressure:

Force was applied to the top of the device until the gate threshold voltage ( $V_{g-th}$ ) shifted by  $\pm 20\%$  (or until the maximum force for the outline was reached).

Stepped pressure:

MQ-outline: Force was raised to 400N, relieved and the device allowed to return to neutral. The force was then raised to 700N and relieved; this process was repeated in steps of 50N until the device failed. The gate threshold was monitored throughout.

MT-outline: The MQ-outline test was replicated but with an initial force of 600N and increments of 100N.

L8-outline: The MT-outline test was replicated but with an initial force of 1200N and termination force of 2000N (the maximum available on the equipment).

Note: Initial pressures were set close to the expected failure point to minimize the number of cycles and, therefore, the fatigue induced by them.

**Results**

The table below shows the average compression required to cause failure in DirectFET devices.

	MQ-outline	MT-outline	L8-outline
Continuous	1204N	1407N	no failures
Stepped	663N	1106N	no failures

Note: Gravity (1g) was assumed to be 9.81ms<sup>-2</sup>.

Figure 22 shows mortality curves for the survival rate of board-mounted MQ- and MT-outline devices when increasing pressure is applied to the top surface.

Survival rates are calculated as follows:

$$\text{Survival rate} = \frac{n_{dt} - n_{df}}{n_{dt}} \times 100$$

$n_{dt}$  Number of devices tested  
 $n_{df}$  Number of devices failed

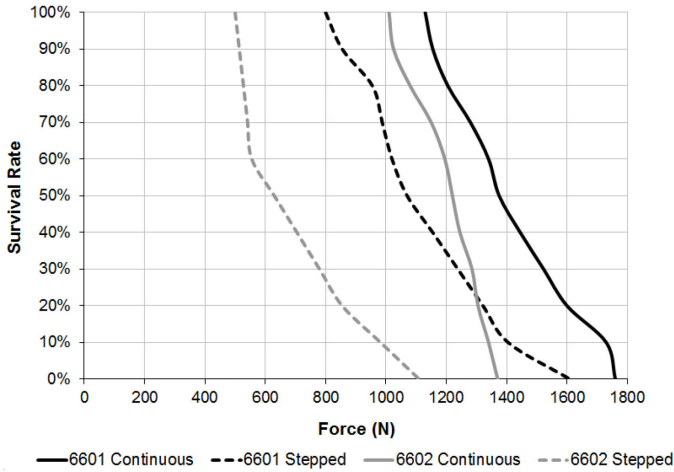

Figure 22 Survival rates of MQ- and MT-outlines

Stress was modeled as a function of device area (top), applied force and die size. The stress on the die from an applied force of 2000N was found to be lower on an L8-outline than on MQ- or MT-outlines (Figure 23). The conclusion is that the larger die in the L8-outline spreads the load, while the smaller die and solder area in the MQ-outline concentrates force and increases stress (Figure 24).

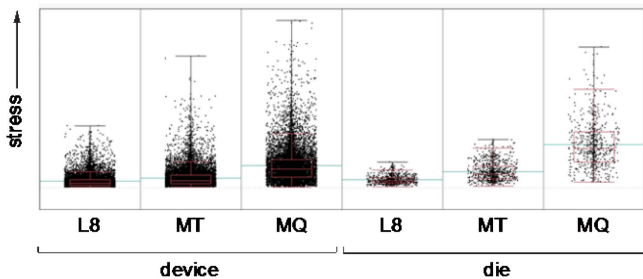

Figure 23 Comparison of stress in device and in die only

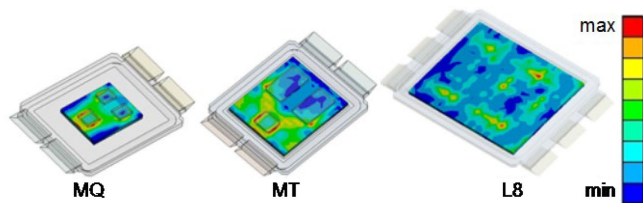

Figure 24 Stress modeling

**Drop tests**

*Method*

These tests were carried out in accordance with BS 2011: Part 2.1 Ed:1992 Test Ed: free fall.

DirectFET devices were dropped onto a steel block from different heights and in five attitudes:

1. On the short edge of the device
2. On the long edge of the device
3. On the corner of the device
4. With device flat, on top of the substrate
5. With the device flat, underneath the substrate

BS 2011 specifies drop heights of 25mm, 50mm, 100mm, 250mm, 500mm and 1000mm. When no devices failed, International Rectifier increased the drop height to 1500mm.

*Results*

	MQ-outline		MT-outline	
Drop height (mm)	1000	1500	1000	1500
Attitude 1	0/10	0/10	0/10	0/10
Attitude 2	0/10	0/10	0/10	0/10
Attitude 3	0/10	0/10	0/10	0/10
Attitude 4	0/10	0/10	0/10	0/10
Attitude 5	0/10	0/10	0/10	0/10

Note: 10 devices were tested for each combination of height and attitude. Each device was dropped 20 times.

**Vibration tests**

*Method*

These tests were carried out in accordance with BS 2011: Part 2.1 Fd:1973 Test Fd: random vibration — wide band general requirements.

DirectFET devices were subjected for three hours to random vibrations from 20Hz to 2kHz, experiencing  $3.2g_{rms}$  ( $31.4ms^{-2}_{rms}$ ) with an acceleration spectral density value of  $0.005g^2Hz^{-1}$  ( $[0.48ms^{-2}]^2Hz^{-1}$ ). Figure 25 shows the bandpass filter frequency chart.

The devices were tested in three attitudes:

1. On the short edge of the device
2. On the long edge of the device
3. With device flat, on top of the substrate



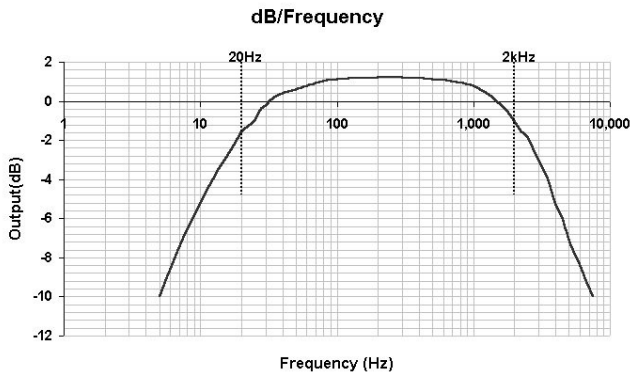

Figure 25 Bandpass filter frequency chart

**Results**

<b>6601</b>	
Attitude 1	0/16
Attitude 2	0/16
Attitude 3	0/16

Note: 16 devices were tested in each attitude.

**Acknowledgements**

International Rectifier would like to thank:  
 Indium Corporation of Europe, Multicore Solders Limited, Litton Kester Solders, Tamura Kaken (UK), Agmet Ltd (ESL Europe) and Alpha Metals for supplying solder paste samples and information.  
 Mike Fenner of Indium, for support during the applications work, and James Taylor of Litton, for providing information on surface mount technologies.  
 The Bergquist Company for supplying insulated metal substrate samples and information.

**Further reading**

Frear, D R; Vianco, P T (1994) 'Intermetallic Growth and Mechanical Behavior of Low and High Melting Temperature Solder Alloys', *Metallurgical and Materials Transactions A*. Vol 25A pp1509-1523 July 1994.  
 Frear, Darrel R (1990) 'Microstructural Evolution during Thermomechanical Fatigue of 62Sn-36Pb-2Ag and 60Sn-40Pb Solder Joints', *IEEE Transactions on Component, Hybrids, and Manufacturing Technology*, Vol 13 No 4 December 1990.  
 Frear, Darrel; Morgan, Harold; Burchett, Steven; Lau, John. *The Mechanics Of Solder Alloy Interconnects*. Chapman & Hall. ISBN 0-442-01505-4.  
 Manko, Howard H (4<sup>th</sup> edn) *Solders and Soldering*. McGraw-Hill. ISBN 0-07-134417-9.  
 Prasad, Ray P (2<sup>nd</sup> edn) *Surface Mount Technology*. Kluwer Academic Publishers. ISBN 0-412-12-12921-3.

**Standards**

BS EN 60068-2-21:2006, Environmental testing. Test U: Robustness of terminations and integral mounting devices.  
 BS EN 60068-2-31:2008, Environmental testing. Test Ec: Rough handling shocks, primarily for equipment-type specimens.  
 BS 2011-2.1Fd:1973, Environmental testing. Test Fd: random vibration — wide band, general requirements.

## Appendix A

### Model-specific data

DirectFET devices are available in a growing range of can sizes and device outlines. At present, there are 21 variants in three can sizes. Devices shown with the die outlined in red use standardized pad layouts (see page 4).

This appendix contains the following information about each combination of can size and device outline currently available:

- Device outline drawing
- Recommended substrate/PCB layout
- Suggested designs for stencils of 0.150mm (0.006") thickness

For more details about individual devices, and to find out their size and outline, refer to the relevant product data sheet and package outline drawing.

#### Note

The die outline colors below indicate device ranges.

Black	Standard DirectFET <sup>®</sup> and DirectFET <sup>®</sup> PbF
Green	DirectFET <sup>®</sup> <i>plus</i>
Red	Automotive DirectFET <sup>®</sup> and DirectFET <sup>®</sup> 2

### Small can outlines

ST-outline

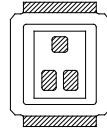

SQ-outline

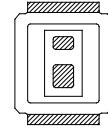

SJ-outline

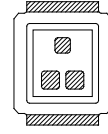

SH-outline

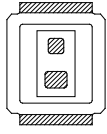

S1-outline



S2-outline



SA-outline

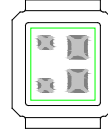

SB-outline



SC-outline

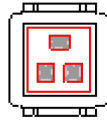

S3C-outline

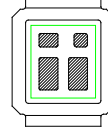

**Medium can outlines**

MT-outline

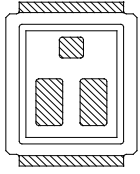

MX-outline

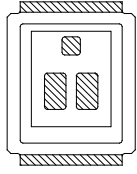

MP-outline

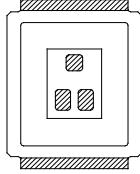

MQ-outline

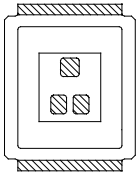

MN-outline

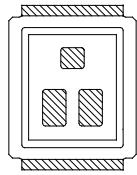

MZ-outline

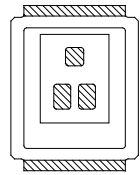

MU-outline

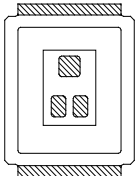

M2-outline

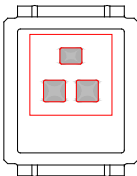

M4-outline

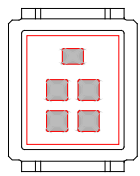

MA-outline

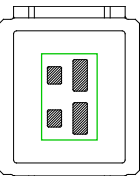

MB-outline

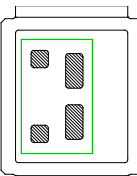

MC-outline

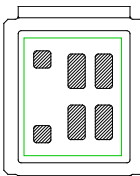

MD-outline

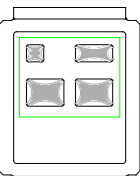

ME-outline

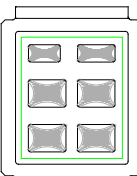

MF-outline

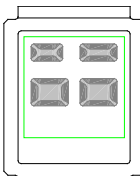

**Large can outlines**

L4-outline

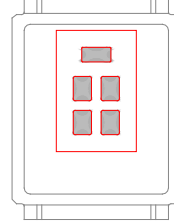

L6-outline

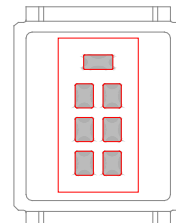

L8-outline

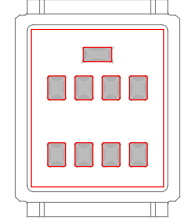

LA-outline

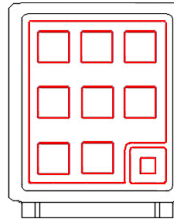

## Appendix A.1 ST-outline

### Device outline

Figure A.1.1 shows the outline for ST-outline DirectFET devices. The relative pad positions are controlled to an accuracy of  $\pm 0.065\text{mm}$ . For full dimensions and tolerances of each device, and to find out its size and outline, refer to the relevant product data sheet and package outline drawing.

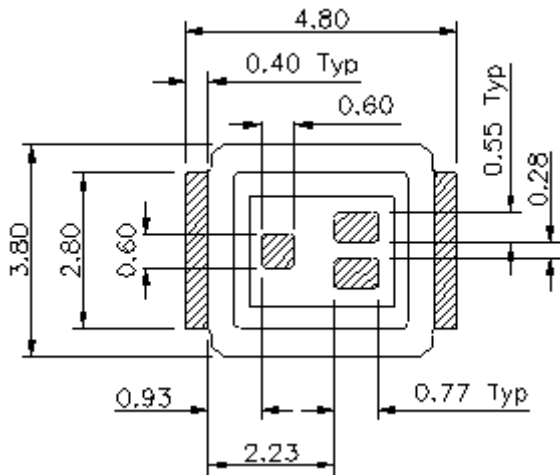

(dimensions in mm)

Figure A.1.1 ST-outline device outline

### Substrate/PCB layout

Evaluations have shown that the best overall performance is achieved using the substrate/PCB layout shown in Figure A.1.2 (a and b). Gate and source pads on the substrate are oversized by 0.025mm (0.001") on each side. Drain pads are thickened by 0.500mm (0.020"). Each drain contact pad is divided into two separate pads, as this has been shown to improve solder joint quality.

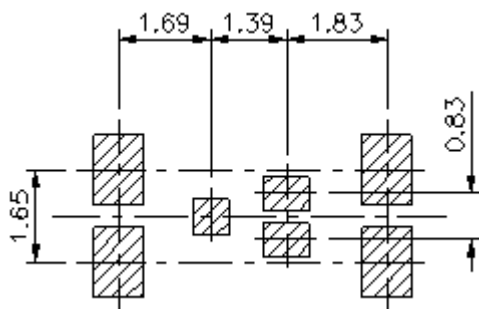

(dimensions in mm)

Figure A.1.2(a) ST-outline substrate/PCB layout

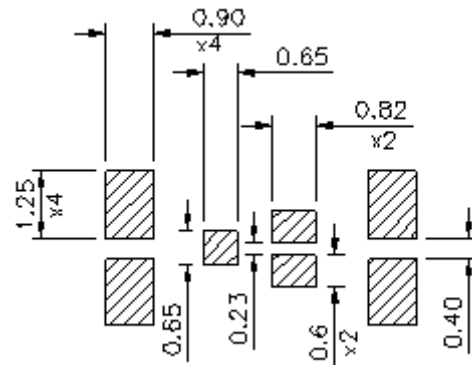

(dimensions in mm)

Figure A.1.2(b) ST-outline substrate/PCB layout

### Stencil design

Evaluations have shown that the best overall performance is achieved using the stencil design shown in Figure A.1.3 (a and b).

Note: This design is for a stencil thickness of 0.150mm (0.006"). The reduction should be adjusted for stencils of other thicknesses.

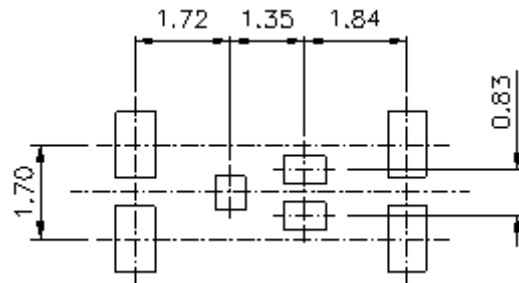

(dimensions in mm)

Figure A.1.3(a) ST-outline stencil design

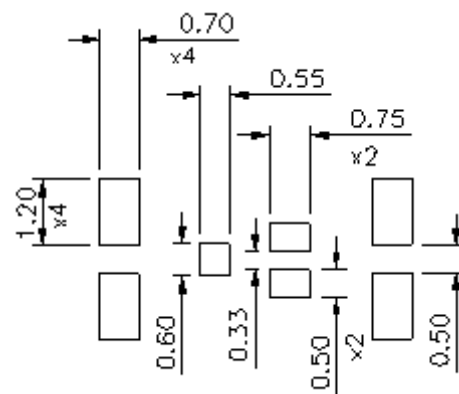

(dimensions in mm)

Figure A.1.3(b) ST-outline stencil design



## Appendix A.2 SQ-outline

### Device outline

Figure A.2.1 shows the outline for SQ-outline DirectFET devices. The relative pad positions are controlled to an accuracy of  $\pm 0.065\text{mm}$ . For full dimensions and tolerances of each device, and to find out its size and outline, refer to the relevant product data sheet and package outline drawing.

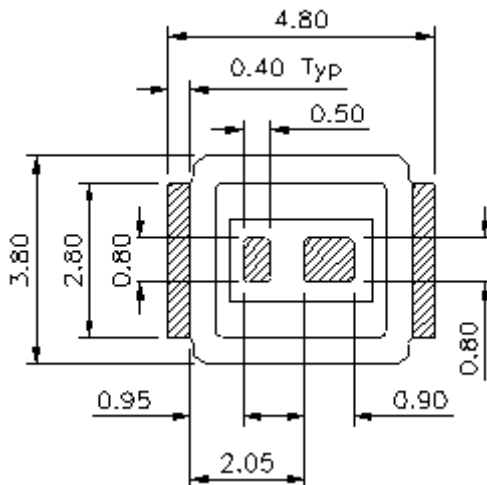

(dimensions in mm)

Figure A.2.1 SQ-outline device outline

### Substrate/PCB layout

Evaluations have shown that the best overall performance is achieved using the substrate/PCB layout shown in Figure A.2.2 (a and b). Gate and source pads on the substrate are oversized by 0.025mm (0.001") on each side. Drain pads are thickened by 0.500mm (0.020"). Each drain contact pad is divided into two separate pads, as this has been shown to improve solder joint quality.

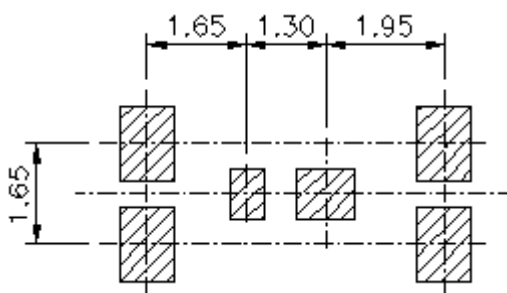

(dimensions in mm)

Figure A.2.2(a) SQ-outline substrate/PCB layout

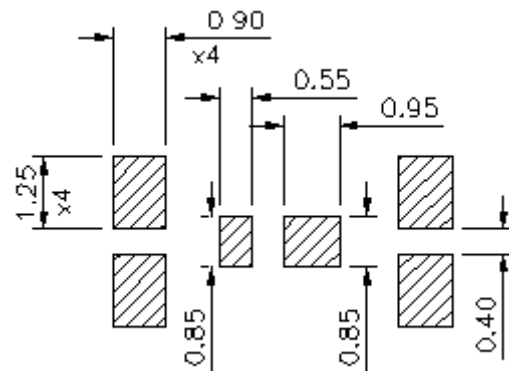

(dimensions in mm)

Figure A.2.2(b) SQ-outline substrate/PCB layout

### Stencil design

Evaluations have shown that the best overall performance is achieved using the stencil design shown in Figure A.2.3 (a and b).

Note: This design is for a stencil thickness of 0.150mm (0.006"). The reduction should be adjusted for stencils of other thicknesses.

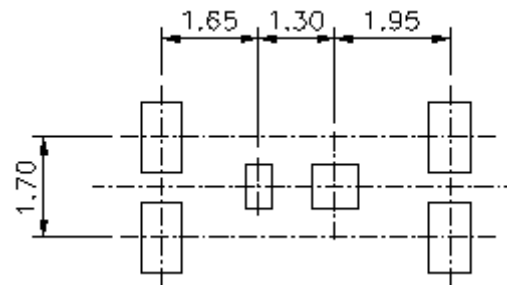

(dimensions in mm)

Figure A.2.3(a) SQ-outline stencil design

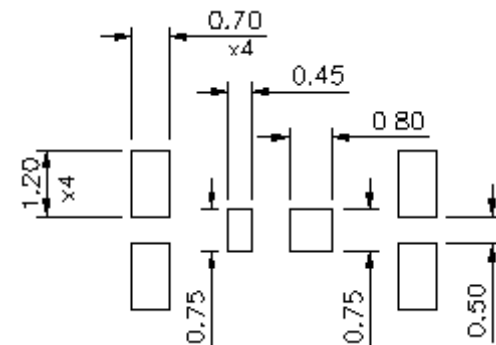

(dimensions in mm)

Figure A.2.3(b) SQ-outline stencil design

## Appendix A.3 SJ-outline

### Device outline

Figure A.3.1 shows the outline for SJ-outline DirectFET devices. The relative pad positions are controlled to an accuracy of  $\pm 0.065\text{mm}$ . For full dimensions and tolerances of each device, and to find out its size and outline, refer to the relevant product data sheet and package outline drawing.

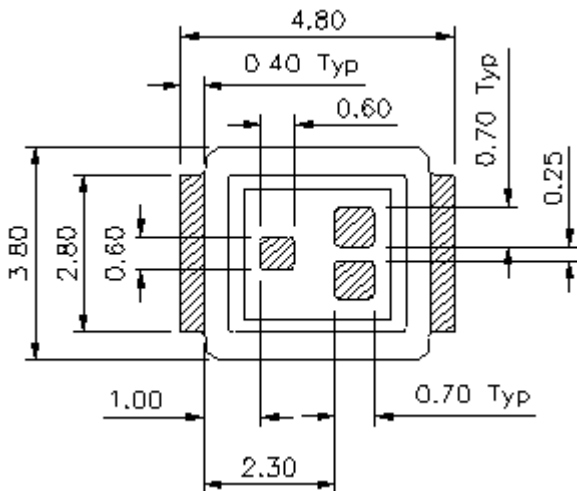

(dimensions in mm)

Figure A.3.1 SJ-outline device outline

### Substrate/PCB layout

Evaluations have shown that the best overall performance is achieved using the substrate/PCB layout shown in Figure A.3.2 (a and b). Gate and source pads on the substrate are oversized by 0.025mm (0.001") on each side. Drain pads are thickened by 0.500mm (0.020"). Each drain contact pad is divided into two separate pads, as this has been shown to improve solder joint quality.

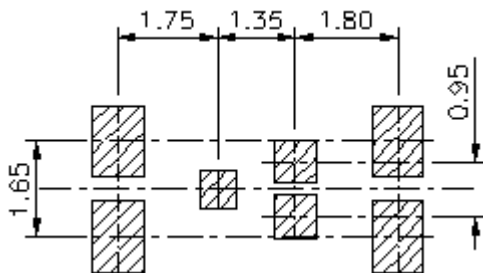

(dimensions in mm)

Figure A.3.2(a) SJ-outline substrate/PCB layout

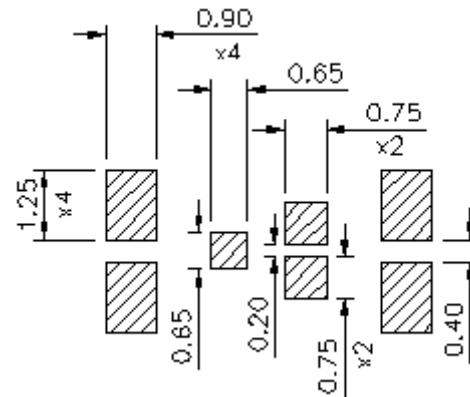

(dimensions in mm)

Figure A.3.2(b) SJ-outline substrate/PCB layout

### Stencil design

Evaluations have shown that the best overall performance is achieved using the stencil design shown in Figure A.3.3 (a and b).

Note: This design is for a stencil thickness of 0.150mm (0.006"). The reduction should be adjusted for stencils of other thicknesses.

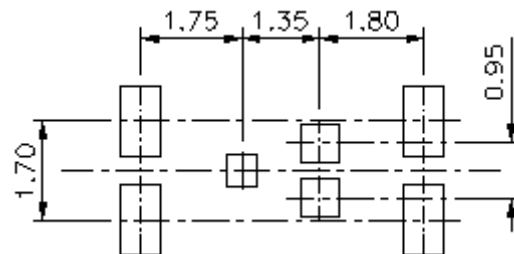

(dimensions in mm)

Figure A.3.3(a) SJ-outline stencil design

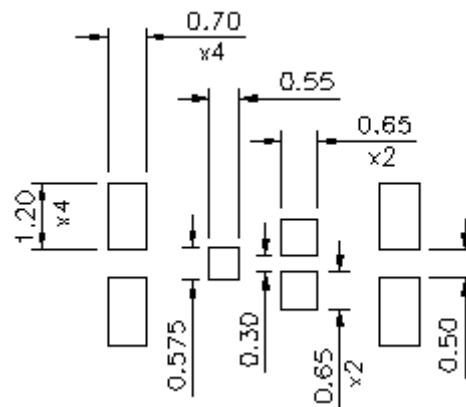

(dimensions in mm)

Figure A.3.3(b) SJ-outline stencil design

## Appendix A.4 SH-outline

### Device outline

Figure A.4.1 shows the outline for SH-outline DirectFET devices. The relative pad positions are controlled to an accuracy of  $\pm 0.065\text{mm}$ . For full dimensions and tolerances of each device, and to find out its size and outline, refer to the relevant product data sheet and package outline drawing.

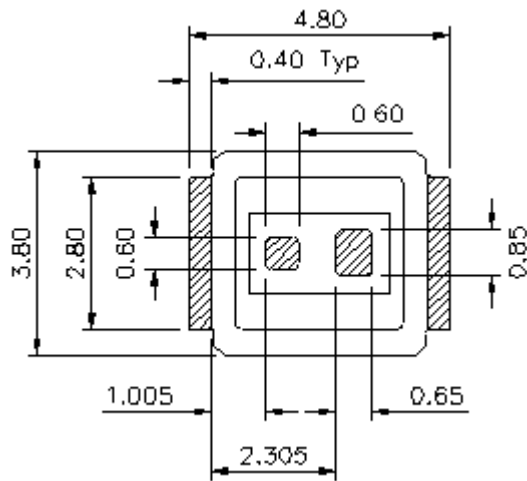

(dimensions in mm)

Figure A.4.1 SH-outline device outline

### Substrate/PCB layout

Evaluations have shown that the best overall performance is achieved using the substrate/PCB layout shown in Figure A.4.2 (a and b). Gate and source pads on the substrate are oversized by  $0.025\text{mm}$  ( $0.001''$ ) on each side. Drain pads are thickened by  $0.500\text{mm}$  ( $0.020''$ ). Each drain contact pad is divided into two separate pads, as this has been shown to improve solder joint quality.

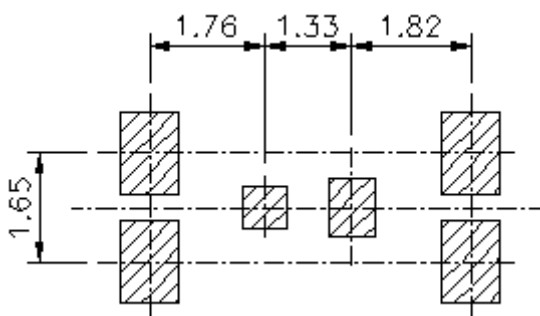

(dimensions in mm)

Figure A.4.2(a) SH-outline substrate/PCB layout

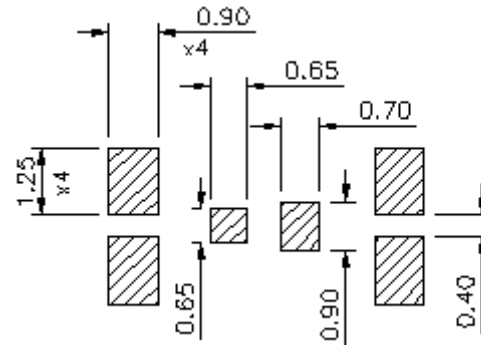

(dimensions in mm)

Figure A.4.2(b) SH-outline substrate/PCB layout

### Stencil design

Evaluations have shown that the best overall performance is achieved using the stencil design shown in Figure A.4.3 (a and b).

Note: This design is for a stencil thickness of  $0.150\text{mm}$  ( $0.006''$ ). The reduction should be adjusted for stencils of other thicknesses.

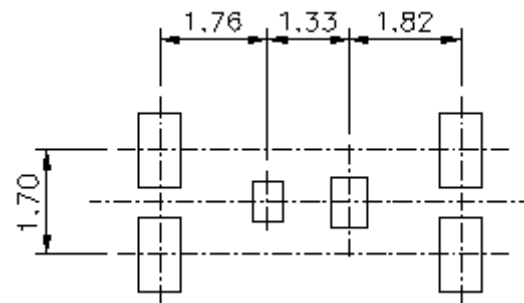

(dimensions in mm)

Figure A.4.3(a) SH-outline stencil design

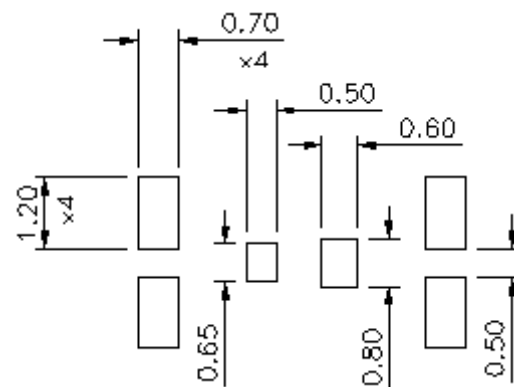

(dimensions in mm)

Figure A.4.3(b) SH-outline stencil design

## Appendix A.5 S1-outline

### Device outline

Figure A.5.1 shows the outline for S1-outline DirectFET devices. The relative pad positions are controlled to an accuracy of  $\pm 0.065\text{mm}$ . For full dimensions and tolerances of each device, and to find out its size and outline, refer to the relevant product data sheet and package outline drawing.

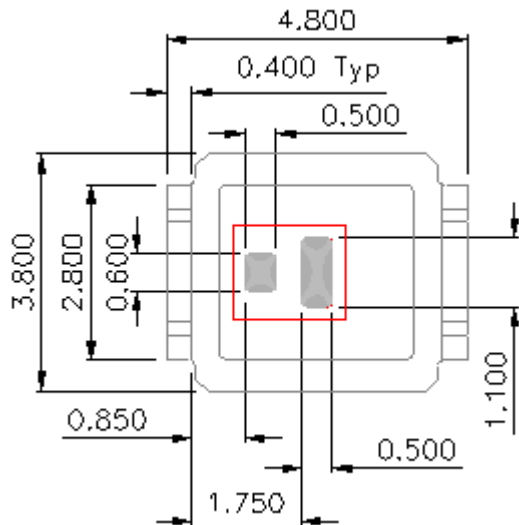

(dimensions in mm)

Figure A.5.1 S1-outline device outline

### Substrate/PCB layout

Evaluations have shown that the best overall performance is achieved using the substrate/PCB layout shown in Figure A.5.2 (a and b). Gate and source pads on the substrate are oversized by 0.025mm (0.001") on each side. Drain pads are thickened by 0.500mm (0.020"). Each drain contact pad is divided into two separate pads, as this has been shown to improve solder joint quality.

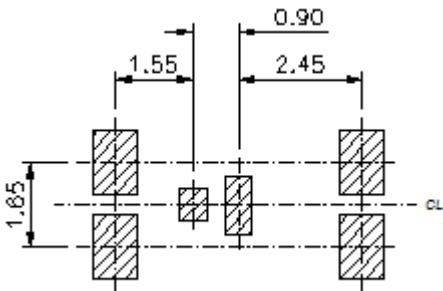

(dimensions in mm)

Figure A.5.2(a) S1-outline substrate/PCB layout

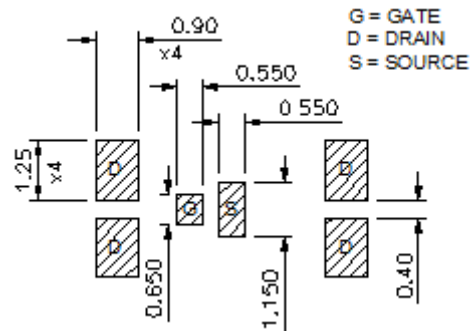

(dimensions in mm)

Figure A.5.2(b) S1-outline substrate/PCB layout

### Stencil design

Evaluations have shown that the best overall performance is achieved using the stencil design shown in Figure A.5.3 (a and b).

Note: This design is for a stencil thickness of 0.150mm (0.006"). The reduction should be adjusted for stencils of other thicknesses.

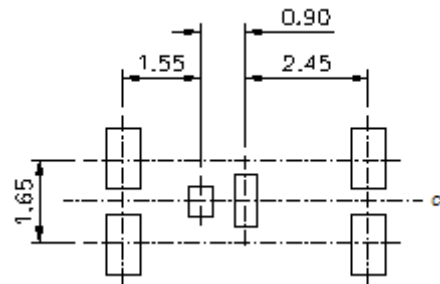

(dimensions in mm)

Figure A.5.3(a) S1-outline stencil design

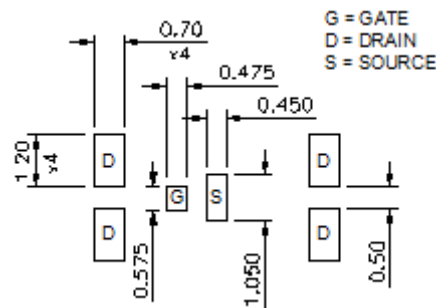

(dimensions in mm)

Figure A.5.3(b) S1-outline stencil design



## Appendix A.6 S2-outline

### Device outline

Figure A.6.1 shows the outline for S2-outline DirectFET devices. The relative pad positions are controlled to an accuracy of  $\pm 0.065\text{mm}$ . For full dimensions and tolerances of each device, and to find out its size and outline, refer to the relevant product data sheet and package outline drawing.

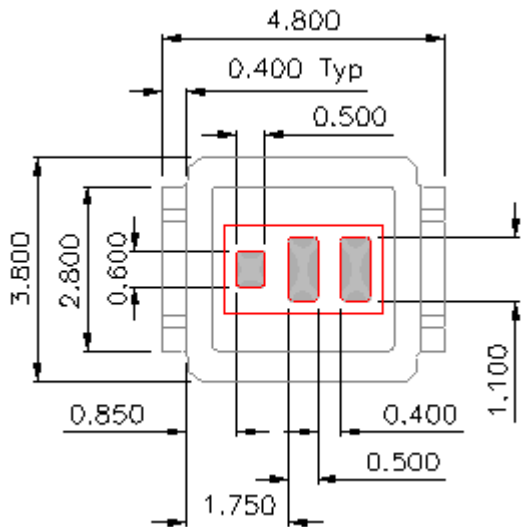

(dimensions in mm)

Figure A.6.1 S2-outline device outline

### Substrate/PCB layout

Evaluations have shown that the best overall performance is achieved using the substrate/PCB layout shown in Figure A.6.2 (a and b). Gate and source pads on the substrate are oversized by 0.025mm (0.001") on each side. Drain pads are thickened by 0.500mm (0.020"). Each drain contact pad is divided into two separate pads, as this has been shown to improve solder joint quality.

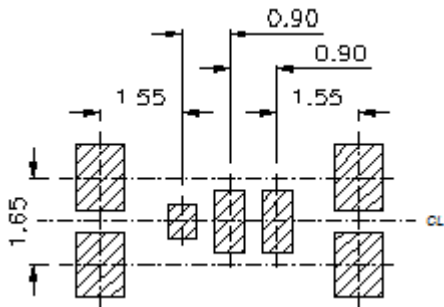

(dimensions in mm)

Figure A.6.2(a) S2-outline substrate/PCB layout

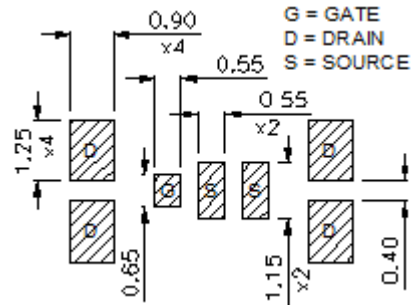

(dimensions in mm)

Figure A.6.2(b) S2-outline substrate/PCB layout

### Stencil design

Evaluations have shown that the best overall performance is achieved using the stencil design shown in Figure A.6.3 (a and b).

Note: This design is for a stencil thickness of 0.150mm (0.006"). The reduction should be adjusted for stencils of other thicknesses.

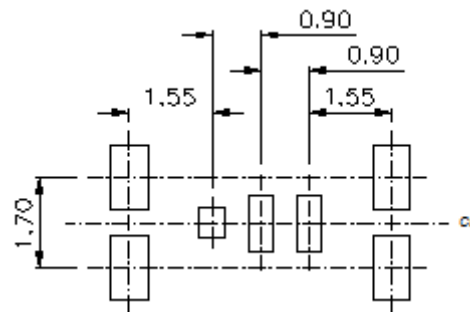

(dimensions in mm)

Figure A.6.3(a) S2-outline stencil design

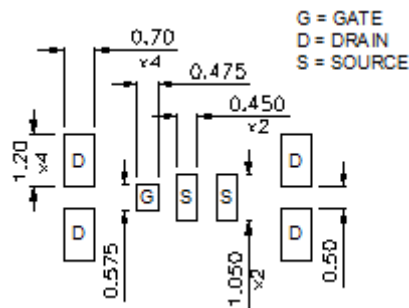

(dimensions in mm)

Figure A.6.3(b) S2-outline stencil design

## Appendix A.7 SA-outline

### Device outline

Figure A.7.1 shows the outline for SA-outline DirectFET devices. The relative pad positions are controlled to an accuracy of  $\pm 0.065\text{mm}$ . For full dimensions and tolerances of each device, and to find out its size and outline, refer to the relevant product data sheet and package outline drawing.

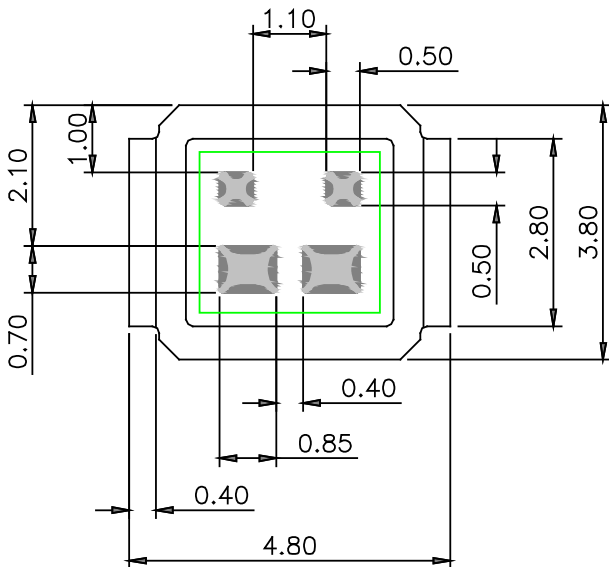

(dimensions in mm)

Figure A.7.1 SA-outline device outline

### Substrate/PCB layout

Evaluations have shown that the best overall performance is achieved using the substrate/PCB layout shown in Figure A.7.2 (a and b). Gate and source pads on the substrate are oversized by 0.025mm (0.001") on each side. Drain pads are thickened by 0.500mm (0.020"). Each drain contact pad is divided into two separate pads, as this has been shown to improve solder joint quality.

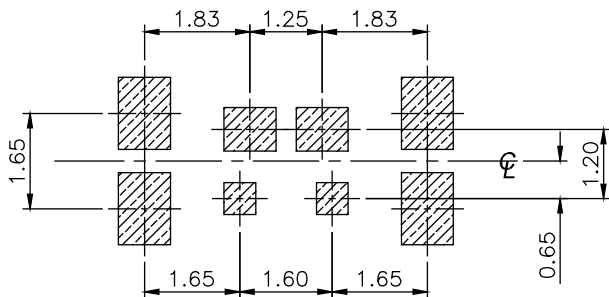

(dimensions in mm)

Figure A.7.2(a) SA-outline substrate/PCB layout

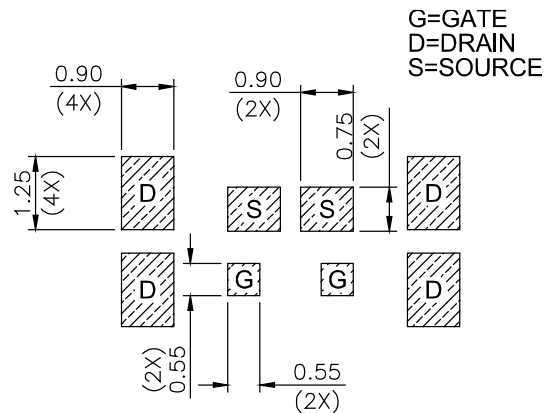

(dimensions in mm)

Figure A.7.2(b) SA-outline substrate/PCB layout

### Stencil design

Evaluations have shown that the best overall performance is achieved using the stencil design shown in Figure A.7.3 (a and b).

Note: This design is for a stencil thickness of 0.150mm (0.006"). The reduction should be adjusted for stencils of other thicknesses.

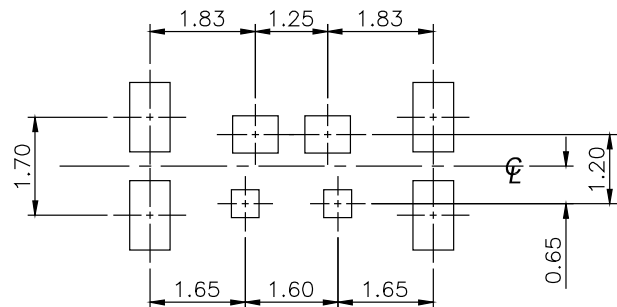

(dimensions in mm)

Figure A.7.3(a) SA-outline stencil design

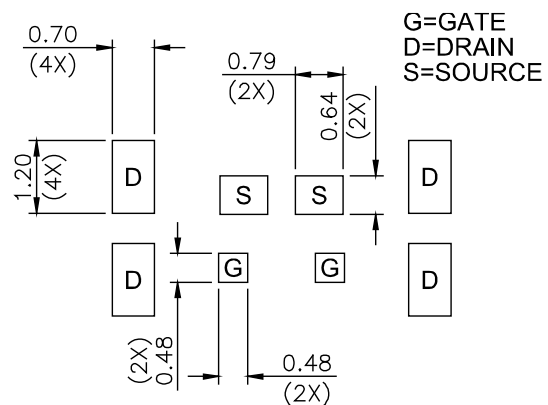

(dimensions in mm)

Figure A.7.3(b) SA-outline stencil design

## Appendix A.8 SB-outline

### Device outline

Figure A.8.1 shows the outline for SB-outline DirectFET devices. The relative pad positions are controlled to an accuracy of  $\pm 0.065\text{mm}$ . For full dimensions and tolerances of each device, and to find out its size and outline, refer to the relevant product data sheet and package outline drawing.

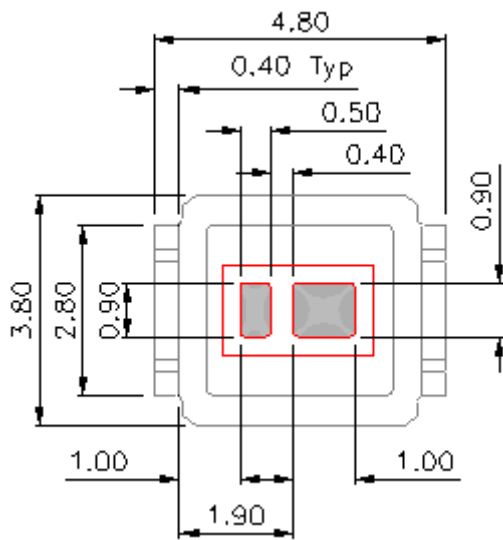

(dimensions in mm)

Figure A.8.1 SB-outline device outline

### Substrate/PCB layout

Evaluations have shown that the best overall performance is achieved using the substrate/PCB layout shown in Figure A.8.2 (a and b). Gate and source pads on the substrate are oversized by 0.025mm (0.001") on each side. Drain pads are thickened by 0.500mm (0.020"). Each drain contact pad is divided into two separate pads, as this has been shown to improve solder joint quality.

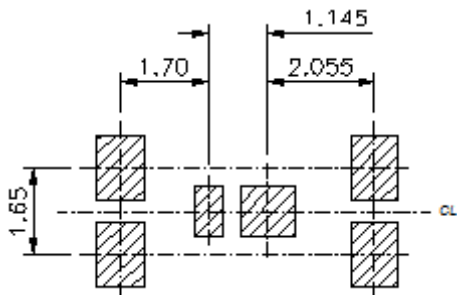

(dimensions in mm)

Figure A.8.2(a) SB-outline substrate/PCB layout

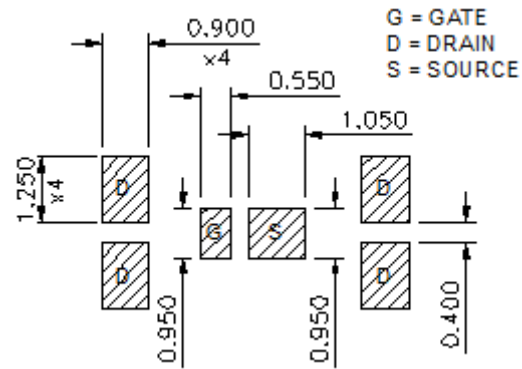

(dimensions in mm)

Figure A.8.2(b) SB-outline substrate/PCB layout

### Stencil design

Evaluations have shown that the best overall performance is achieved using the stencil design shown in Figure A.8.3 (a and b).

Note: This design is for a stencil thickness of 0.150mm (0.006"). The reduction should be adjusted for stencils of other thicknesses.

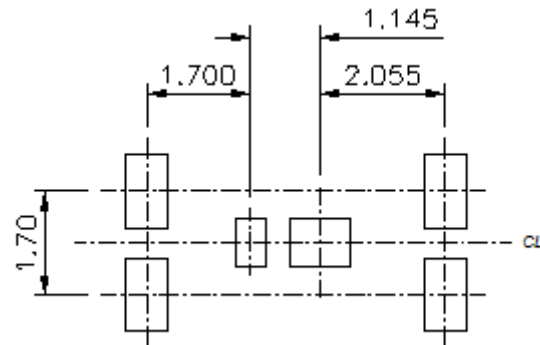

(dimensions in mm)

Figure A.8.3(a) SB-outline stencil design

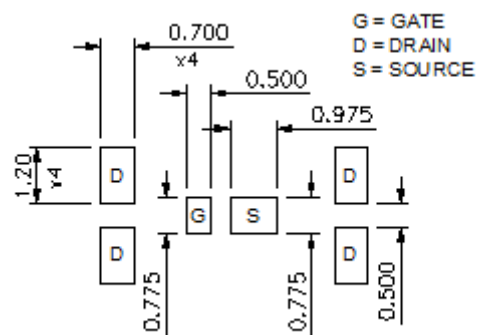

(dimensions in mm)

Figure A.8.3(b) SB-outline stencil design

## Appendix A.9 SC-outline

### Device outline

Figure A.9.1 shows the outline for SC-outline DirectFET devices. The relative pad positions are controlled to an accuracy of  $\pm 0.065\text{mm}$ . For full dimensions and tolerances of each device, and to find out its size and outline, refer to the relevant product data sheet and package outline drawing.

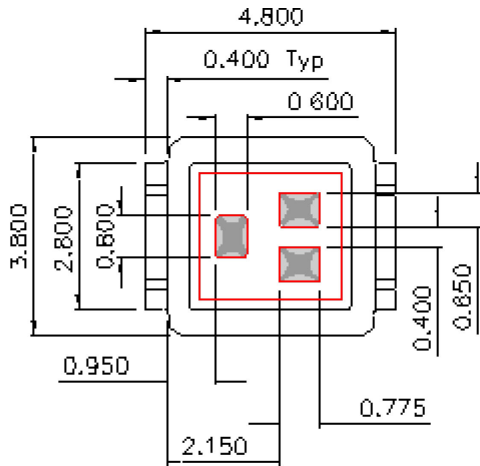

(dimensions in mm)

Figure A.9.1 SC-outline device outline

### Substrate/PCB layout

Evaluations have shown that the best overall performance is achieved using the substrate/PCB layout shown in Figure A.9.2 (a and b). Gate and source pads on the substrate are oversized by 0.025mm (0.001") on each side. Drain pads are thickened by 0.500mm (0.020"). Each drain contact pad is divided into two separate pads, as this has been shown to improve solder joint quality.

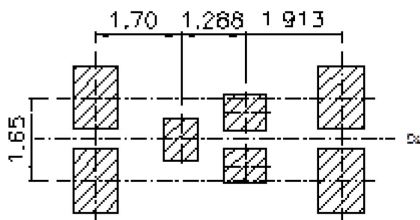

(dimensions in mm)

Figure A.9.2(a) SC-outline substrate/PCB layout

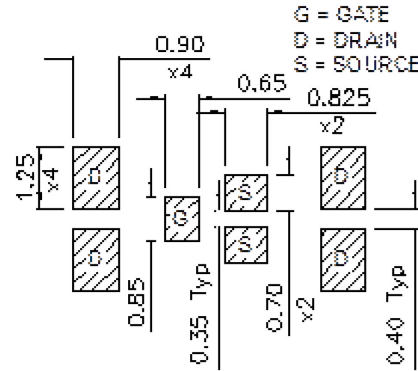

(dimensions in mm)

Figure A.9.2(b) SC-outline substrate/PCB layout

### Stencil design

Evaluations have shown that the best overall performance is achieved using the stencil design shown in Figure A.9.3 (a and b).

Note: This design is for a stencil thickness of 0.150mm (0.006"). The reduction should be adjusted for stencils of other thicknesses.

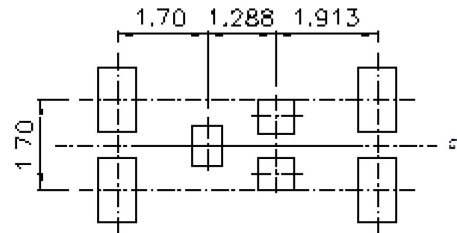

(dimensions in mm)

Figure A.9.3(a) SC-outline stencil design

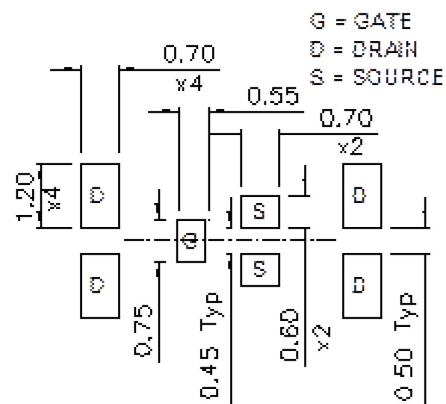

(dimensions in mm)

Figure A.9.3(b) SC-outline stencil design

## Appendix A.10 S3C-outline

### Device outline

Figure A.10.1 shows the outline for S3C-outline DirectFET devices. The relative pad positions are controlled to an accuracy of  $\pm 0.065\text{mm}$ . For full dimensions and tolerances of each device, and to find out its size and outline, refer to the relevant product data sheet and package outline drawing.

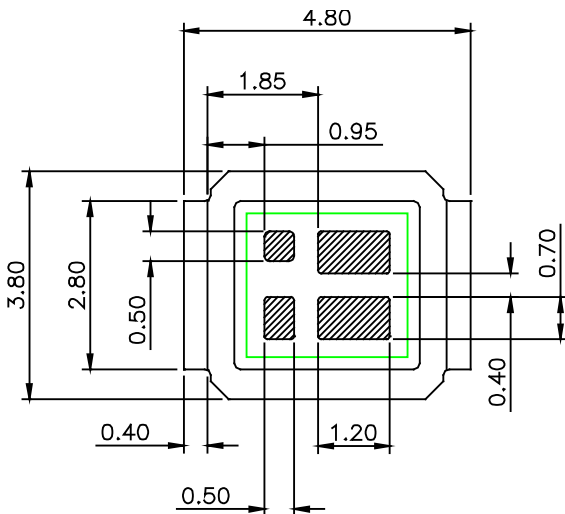

(dimensions in mm)

Figure A.10.1 S3C-outline device outline

### Substrate/PCB layout

Evaluations have shown that the best overall performance is achieved using the substrate/PCB layout shown in Figure A.10.2 (a and b). Gate and source pads on the substrate are oversized by  $0.025\text{mm}$  ( $0.001''$ ) on each side. Drain pads are thickened by  $0.500\text{mm}$  ( $0.020''$ ). Each drain contact pad is divided into two separate pads, as this has been shown to improve solder joint quality.

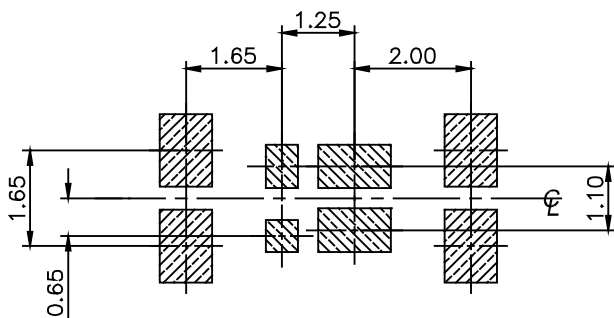

(dimensions in mm)

Figure A.10.2(a) S3C-outline substrate/PCB layout

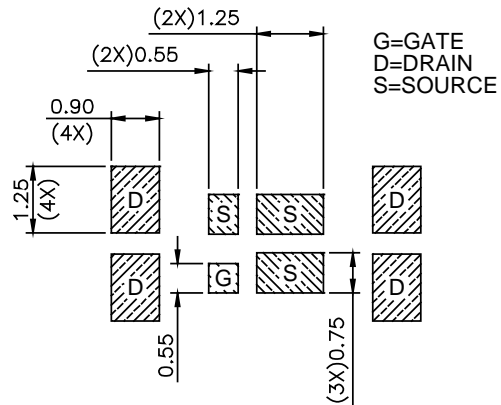

(dimensions in mm)

Figure A.10.2(b) S3C-outline substrate/PCB layout

### Stencil design

Evaluations have shown that the best overall performance is achieved using the stencil design shown in Figure A.10.3 (a and b).

Note: This design is for a stencil thickness of  $0.150\text{mm}$  ( $0.006''$ ). The reduction should be adjusted for stencils of other thicknesses.

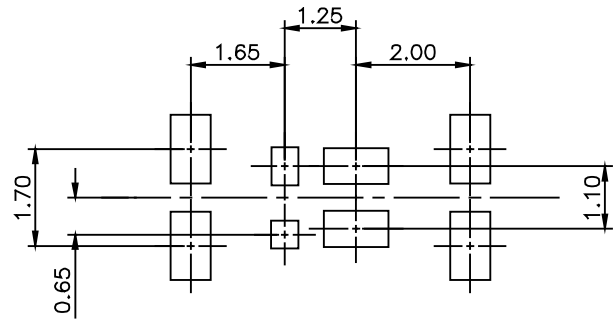

(dimensions in mm)

Figure A.10.3(a) S3C-outline stencil design

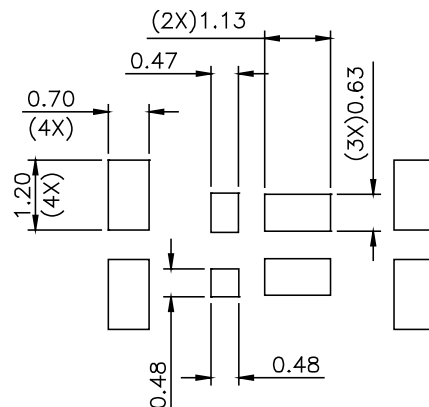

(dimensions in mm)

Figure A.10.3(b) S3C-outline stencil design



## Appendix A.11 MT-outline

### Device outline

Figure A.11.1 shows the outline for MT-outline DirectFET devices. The relative pad positions are controlled to an accuracy of  $\pm 0.065\text{mm}$ . For full dimensions and tolerances of each device, and to find out its size and outline, refer to the relevant product data sheet and package outline drawing.

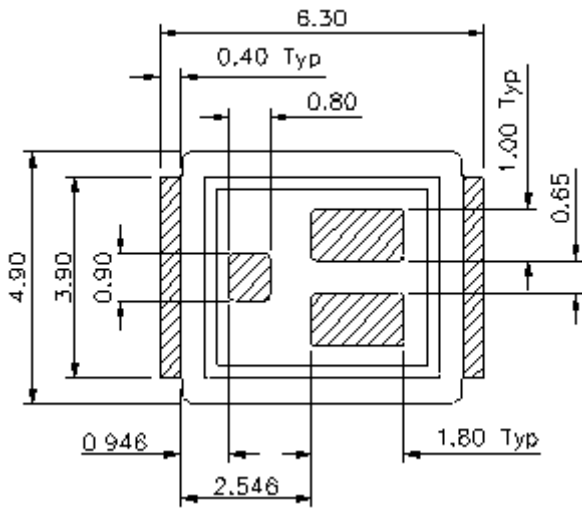

(dimensions in mm)

Figure A.11.1 MT-outline device outline

### Substrate/PCB layout

Evaluations have shown that the best overall performance is achieved using the substrate/PCB layout shown in Figure A.11.2 (a and b). Gate and source pads on the substrate are oversized by 0.025mm (0.001") on each side. Drain pads are thickened by 0.500mm (0.020"). Each drain contact pad is divided into two separate pads, as this has been shown to improve solder joint quality.

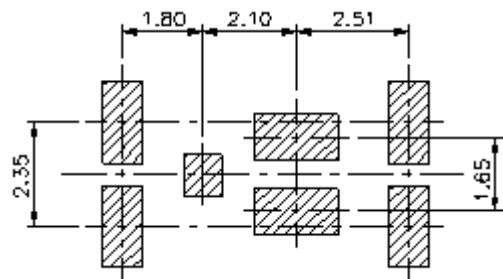

(dimensions in mm)

Figure A.11.2(a) MT-outline substrate/PCB layout

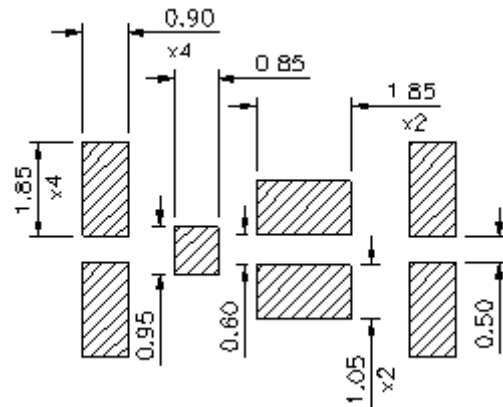

(dimensions in mm)

Figure A.11.2(b) MT-outline substrate/PCB layout

### Stencil design

Evaluations have shown that the best overall performance is achieved using the stencil design shown in Figure A.11.3 (a and b).

Note: This design is for a stencil thickness of 0.150mm (0.006"). The reduction should be adjusted for stencils of other thicknesses.

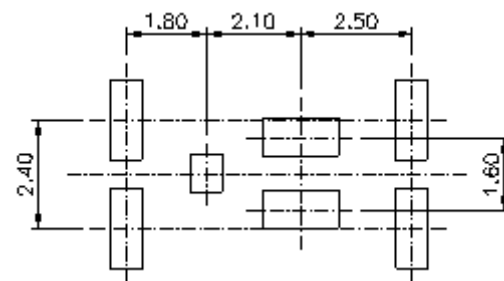

(dimensions in mm)

Figure A.11.3(a) MT-outline stencil design

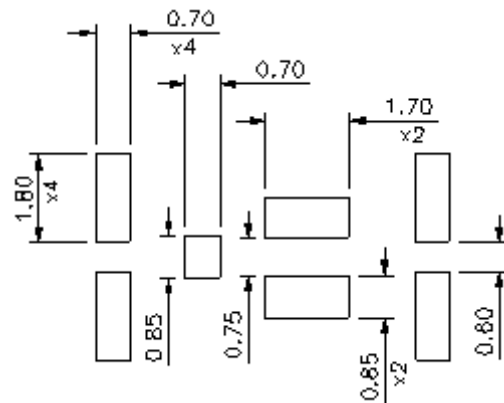

(dimensions in mm)

Figure A.11.3(b) MT-outline stencil design

## Appendix A.12 MX-outline

### Device outline

Figure A.12.1 shows the outline for MX-outline DirectFET devices. The relative pad positions are controlled to an accuracy of  $\pm 0.065\text{mm}$ . For full dimensions and tolerances of each device, and to find out its size and outline, refer to the relevant product data sheet and package outline drawing.

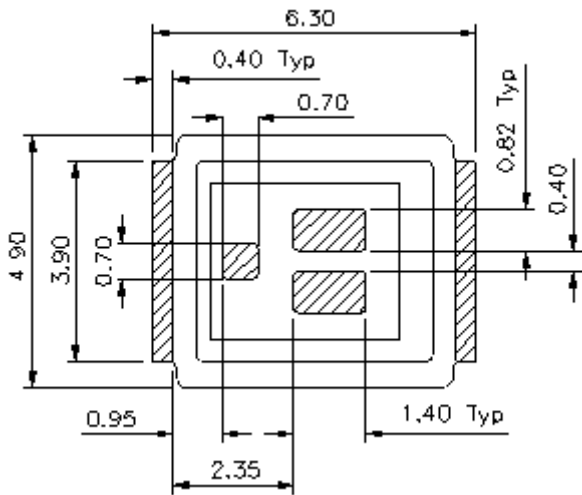

(dimensions in mm)

Figure A.12.1 MX-outline device outline

### Substrate/PCB layout

Evaluations have shown that the best overall performance is achieved using the substrate/PCB layout shown in Figure A.12.2 (a and b). Gate and source pads on the substrate are oversized by  $0.025\text{mm}$  ( $0.001''$ ) on each side. Drain pads are thickened by  $0.500\text{mm}$  ( $0.020''$ ). Each drain contact pad is divided into two separate pads, as this has been shown to improve solder joint quality.

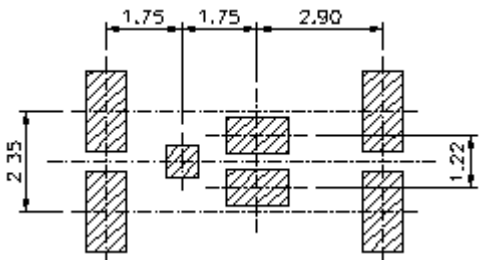

(dimensions in mm)

Figure A.12.2(a) MX-outline substrate/PCB layout

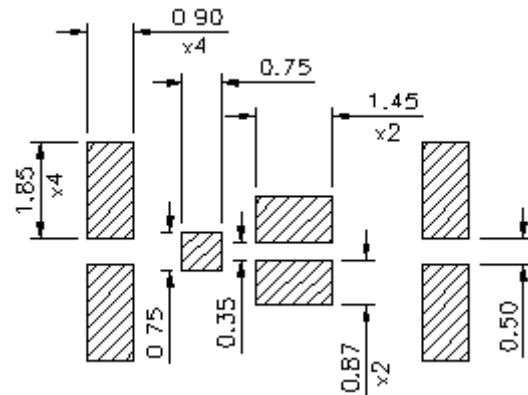

(dimensions in mm)

Figure A.12.2(b) MX-outline substrate/PCB layout

### Stencil design

Evaluations have shown that the best overall performance is achieved using the stencil design shown in Figure A.12.3 (a and b).

Note: This design is for a stencil thickness of  $0.150\text{mm}$  ( $0.006''$ ). The reduction should be adjusted for stencils of other thicknesses.

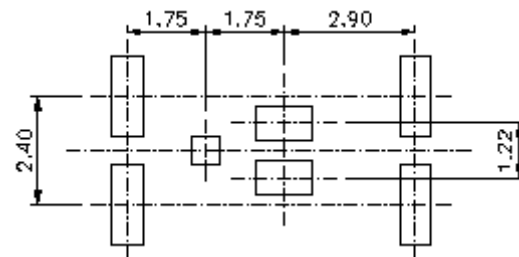

(dimensions in mm)

Figure A.12.3(a) MX-outline stencil design

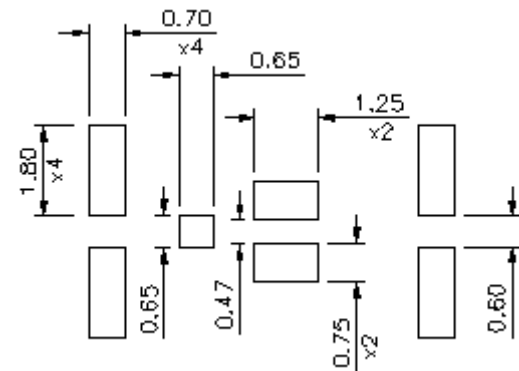

(dimensions in mm)

Figure A.12.3(b) MX-outline stencil design

## Appendix A.13 MP-outline

### Device outline

Figure A.13.1 shows the outline for MP-outline DirectFET devices. The relative pad positions are controlled to an accuracy of  $\pm 0.065\text{mm}$ . For full dimensions and tolerances of each device, and to find out its size and outline, refer to the relevant product data sheet and package outline drawing.

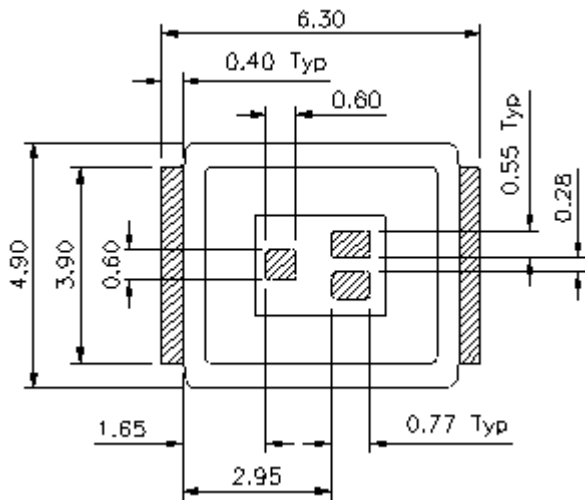

(dimensions in mm)

Figure A.13.1 MP-outline device outline

### Substrate/PCB layout

Evaluations have shown that the best overall performance is achieved using the substrate/PCB layout shown in Figure A.13.2 (a and b). Gate and source pads on the substrate are oversized by  $0.025\text{mm}$  ( $0.001''$ ) on each side. Drain pads are thickened by  $0.500\text{mm}$  ( $0.020''$ ). Each drain contact pad is divided into two separate pads, as this has been shown to improve solder joint quality.

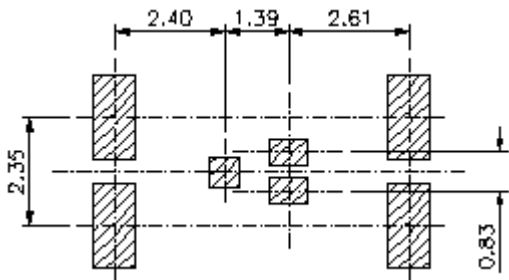

(dimensions in mm)

Figure A.13.2(a) MP-outline substrate/PCB layout

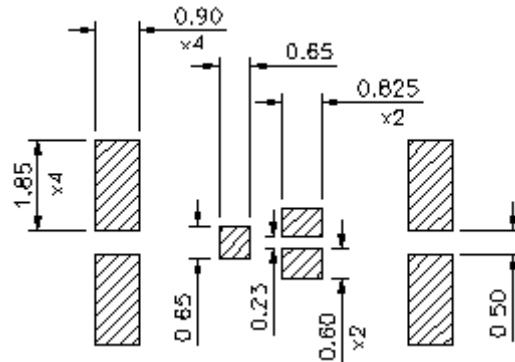

(dimensions in mm)

Figure A.13.2(b) MP-outline substrate/PCB layout

### Stencil design

Evaluations have shown that the best overall performance is achieved using the stencil design shown in Figure A.13.3 (a and b).

Note: This design is for a stencil thickness of  $0.150\text{mm}$  ( $0.006''$ ). The reduction should be adjusted for stencils of other thicknesses.

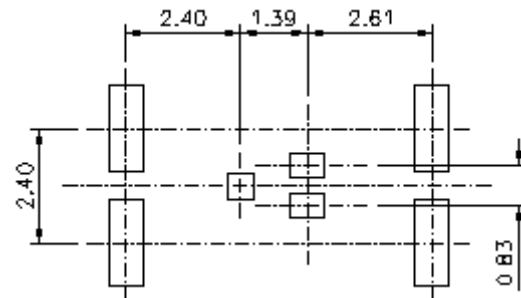

(dimensions in mm)

Figure A.13.3(a) MP-outline stencil design

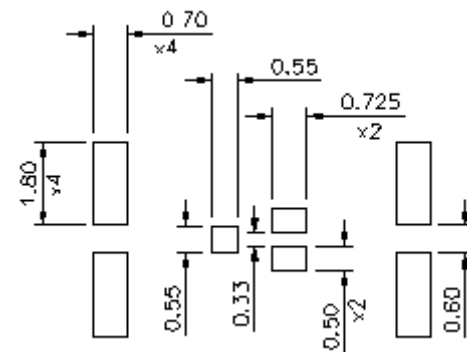

(dimensions in mm)

Figure A.13.3(b) MP-outline stencil design

## Appendix A.14 MQ-outline

### Device outline

Figure A.14.1 shows the outline for MQ-outline DirectFET devices. The relative pad positions are controlled to an accuracy of  $\pm 0.065\text{mm}$ . For full dimensions and tolerances of each device, and to find out its size and outline, refer to the relevant product data sheet and package outline drawing.

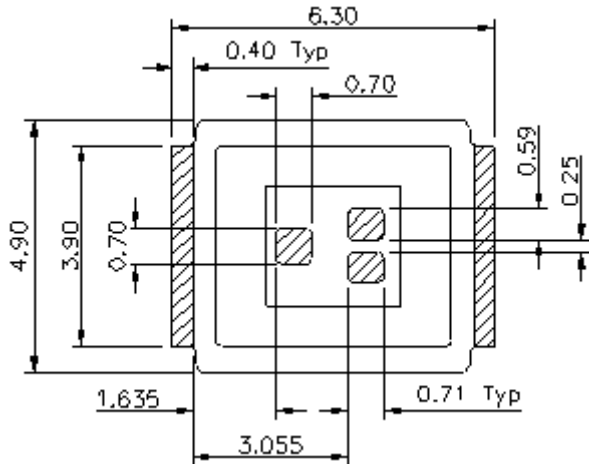

(dimensions in mm)

Figure A.14.1 MQ-outline device outline

### Substrate/PCB layout

Evaluations have shown that the best overall performance is achieved using the substrate/PCB layout shown in Figure A.14.2 (a and b). Gate and source pads on the substrate are oversized by 0.025mm (0.001") on each side. Drain pads are thickened by 0.500mm (0.020"). Each drain contact pad is divided into two separate pads, as this has been shown to improve solder joint quality.

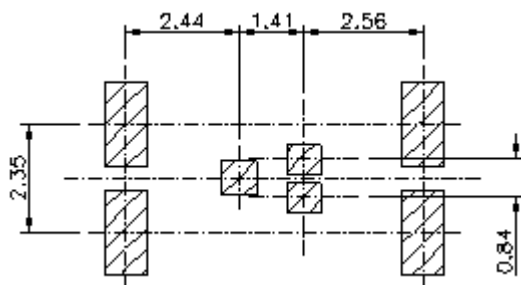

(dimensions in mm)

Figure A.14.2(a) MQ-outline substrate/PCB layout

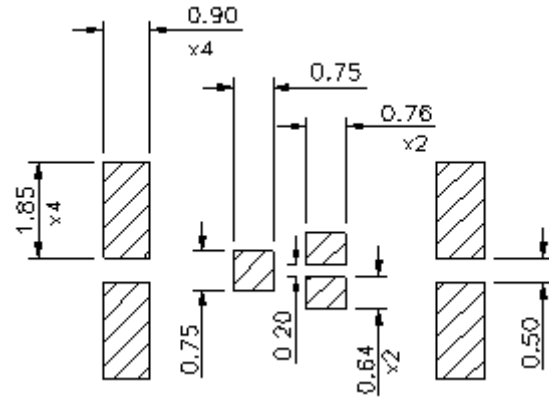

(dimensions in mm)

Figure A.14.2(b) MQ-outline substrate/PCB layout

### Stencil design

Evaluations have shown that the best overall performance is achieved using the stencil design shown in Figure A.14.3 (a and b).

Note: This design is for a stencil thickness of 0.150mm (0.006"). The reduction should be adjusted for stencils of other thicknesses.

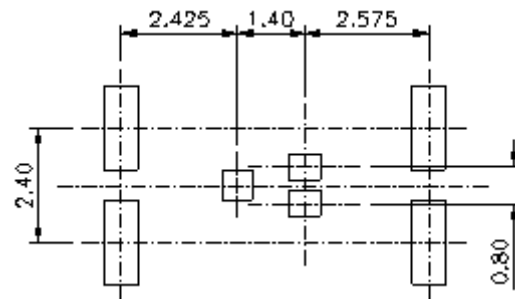

(dimensions in mm)

Figure A.14.3(a) MQ-outline stencil design

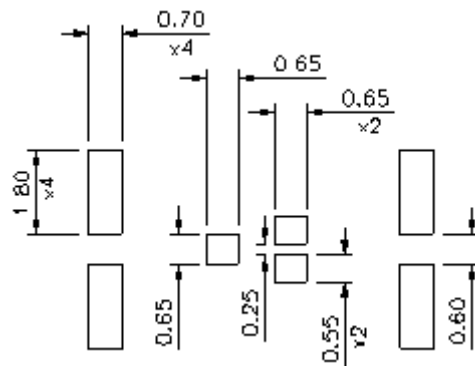

(dimensions in mm)

Figure A.14.3(b) MQ-outline stencil design

## Appendix A.15 MN-outline

### Device outline

Figure A.15.1 shows the outline for MN-outline DirectFET devices. The relative pad positions are controlled to an accuracy of  $\pm 0.065\text{mm}$ . For full dimensions and tolerances of each device, and to find out its size and outline, refer to the relevant product data sheet and package outline drawing.

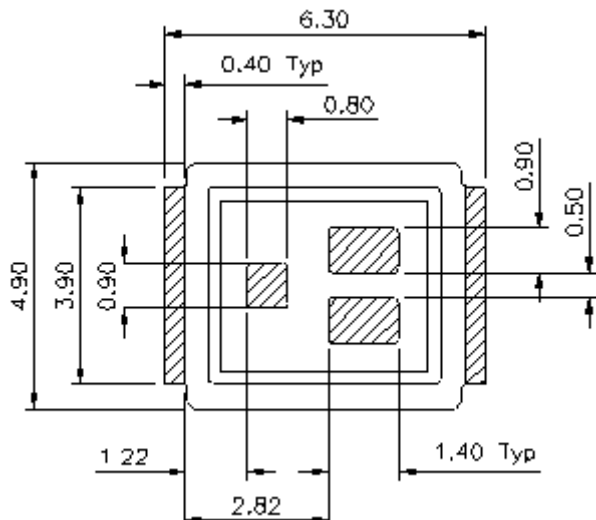

(dimensions in mm)

Figure A.15.1 MN-outline device outline

### Substrate/PCB layout

Evaluations have shown that the best overall performance is achieved using the substrate/PCB layout shown in Figure A.15.2 (a and b). Gate and source pads on the substrate are oversized by 0.025mm (0.001") on each side. Drain pads are thickened by 0.500mm (0.020"). Each drain contact pad is divided into two separate pads, as this has been shown to improve solder joint quality.

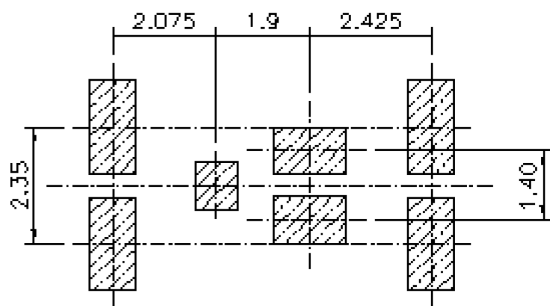

(dimensions in mm)

Figure A.15.2(a) MN-outline substrate/PCB layout

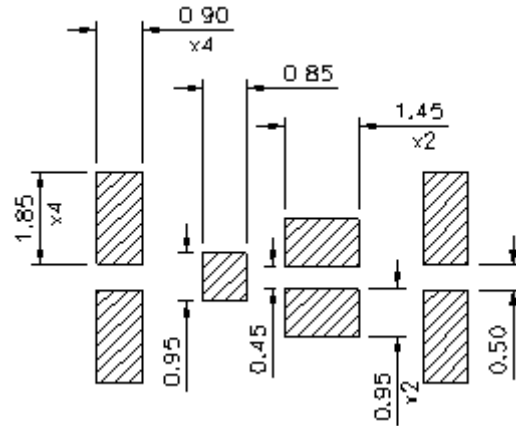

(dimensions in mm)

Figure A.15.2(b) MN-outline substrate/PCB layout

### Stencil design

Evaluations have shown that the best overall performance is achieved using the stencil design shown in Figure A.15.3 (a and b).

Note: This design is for a stencil thickness of 0.150mm (0.006"). The reduction should be adjusted for stencils of other thicknesses.

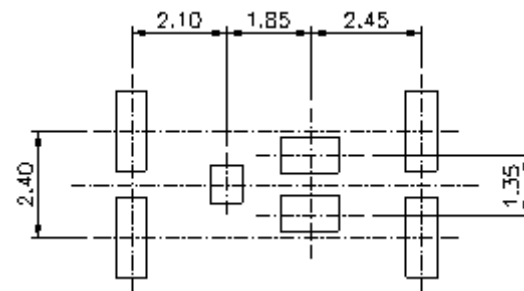

(dimensions in mm)

Figure A.15.3(a) MN-outline stencil design

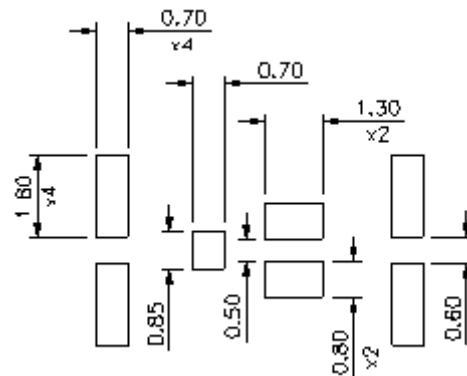

(dimensions in mm)

Figure A.15.3(b) MN-outline stencil design



## Appendix A.16 MZ-outline

### Device outline

Figure A.16.1 shows the outline for MZ-outline DirectFET devices. The relative pad positions are controlled to an accuracy of  $\pm 0.065\text{mm}$ . For full dimensions and tolerances of each device, and to find out its size and outline, refer to the relevant product data sheet and package outline drawing.

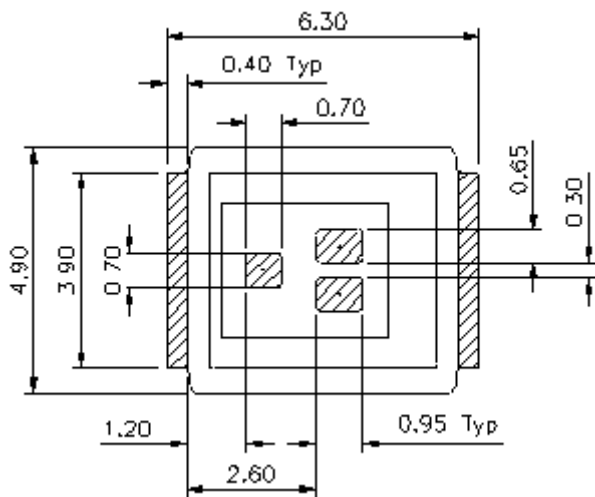

(dimensions in mm)

Figure A.16.1 MZ-outline device outline

### Substrate/PCB layout

Evaluations have shown that the best overall performance is achieved using the substrate/PCB layout shown in Figure A.16.2 (a and b). Gate and source pads on the substrate are oversized by  $0.025\text{mm}$  ( $0.001''$ ) on each side. Drain pads are thickened by  $0.500\text{mm}$  ( $0.020''$ ). Each drain contact pad is divided into two separate pads, as this has been shown to improve solder joint quality.

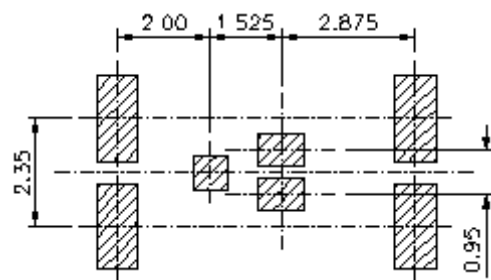

(dimensions in mm)

Figure A.16.2(a) MZ-outline substrate/PCB layout

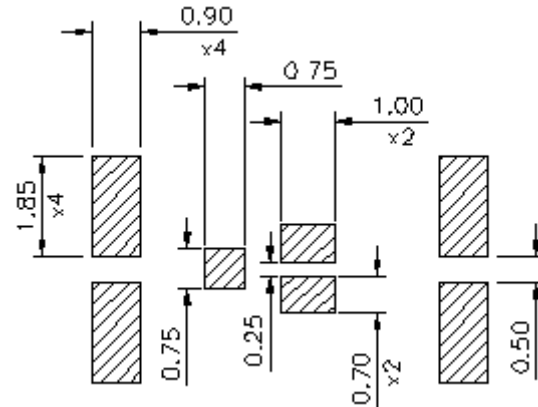

(dimensions in mm)

Figure A.16.2(b) MZ-outline substrate/PCB layout

### Stencil design

Evaluations have shown that the best overall performance is achieved using the stencil design shown in Figure A.16.3 (a and b).

Note: This design is for a stencil thickness of  $0.150\text{mm}$  ( $0.006''$ ). The reduction should be adjusted for stencils of other thicknesses.

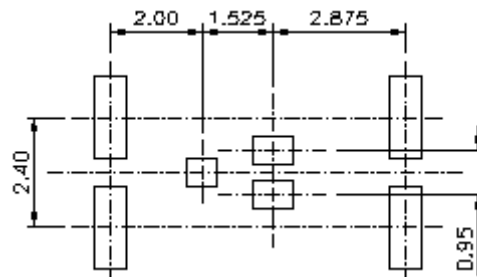

(dimensions in mm)

Figure A.16.3(a) MZ-outline stencil design

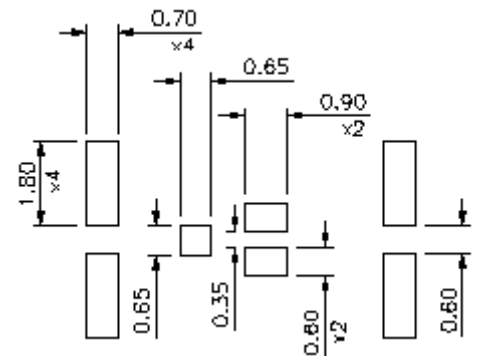

(dimensions in mm)

Figure A.16.3(b) MZ-outline stencil design

## Appendix A.17 MU-outline

### Device outline

Figure A.17.1 shows the outline for MU-outline DirectFET devices. The relative pad positions are controlled to an accuracy of  $\pm 0.065\text{mm}$ . For full dimensions and tolerances of each device, and to find out its size and outline, refer to the relevant product data sheet and package outline drawing.

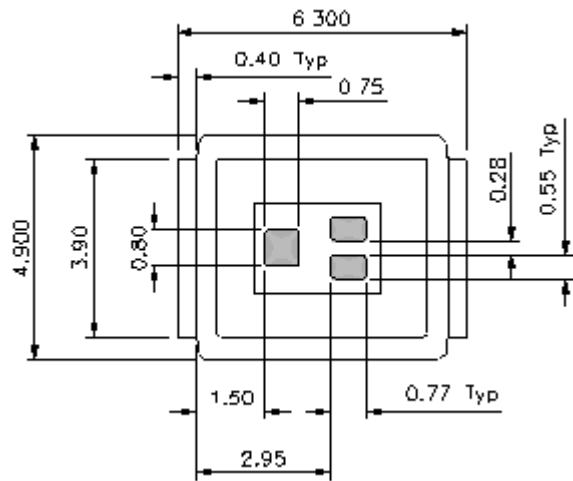

(dimensions in mm)

Figure A.17.1 MU-outline device outline

### Substrate/PCB layout

Evaluations have shown that the best overall performance is achieved using the substrate/PCB layout shown in Figure A.17.2 (a and b). Gate and source pads on the substrate are oversized by 0.025mm (0.001") on each side. Drain pads are thickened by 0.500mm (0.020"). Each drain contact pad is divided into two separate pads, as this has been shown to improve solder joint quality.

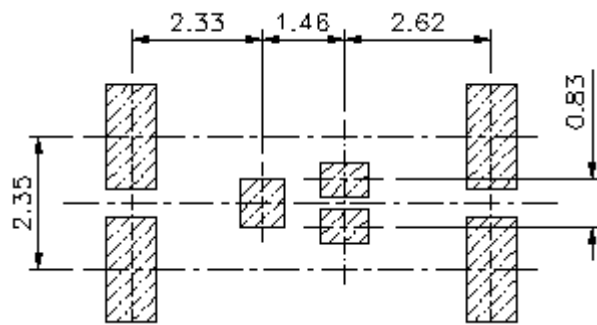

(dimensions in mm)

Figure A.17.2(a) MU-outline substrate/PCB layout

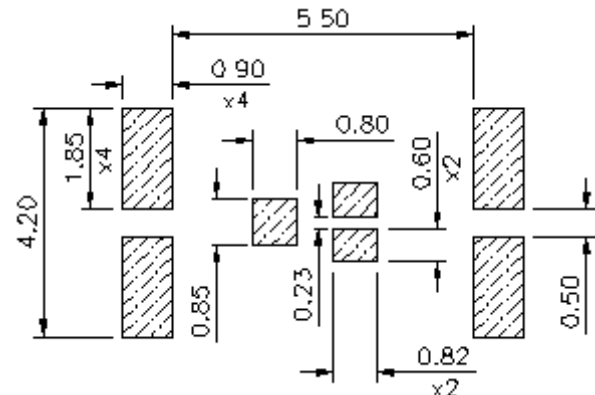

(dimensions in mm)

Figure A.17.2(b) MU-outline substrate/PCB layout

### Stencil design

Evaluations have shown that the best overall performance is achieved using the stencil design shown in Figure A.17.3 (a and b).

Note: This design is for a stencil thickness of 0.150mm (0.006"). The reduction should be adjusted for stencils of other thicknesses.

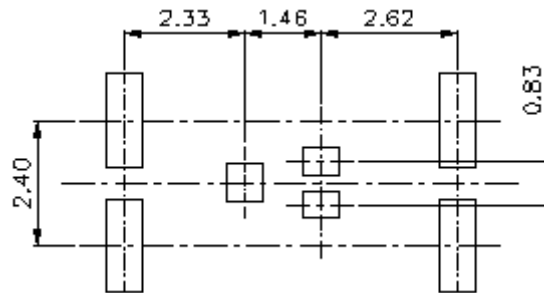

(dimensions in mm)

Figure A.17.3(a) MU-outline stencil design

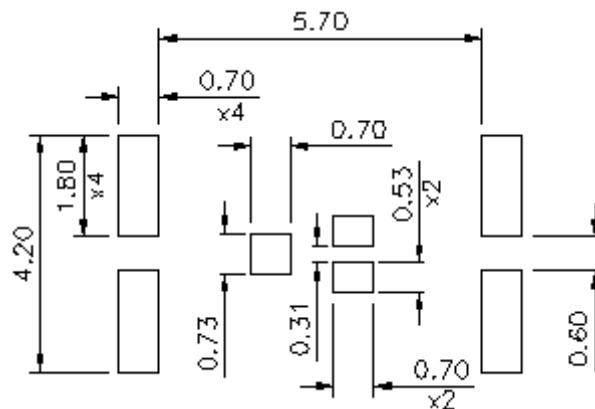

(dimensions in mm)

Figure A.17.3(b) MU-outline stencil design

## Appendix A.18 M2-outline

### Device outline

Figure A.18.1 shows the outline for M2-outline DirectFET devices. The relative pad positions are controlled to an accuracy of  $\pm 0.065\text{mm}$ . For full dimensions and tolerances of each device, and to find out its size and outline, refer to the relevant product data sheet and package outline drawing.

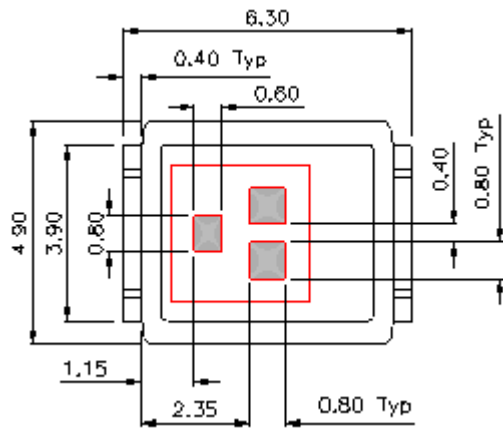

(dimensions in mm)

Figure A.18.1 M2-outline device outline

### Substrate/PCB layout

Evaluations have shown that the best overall performance is achieved using the substrate/PCB layout shown in Figure A.18.2 (a and b). Gate and source pads on the substrate are oversized by 0.025mm (0.001") on each side. Drain pads are thickened by 0.500mm (0.020"). Each drain contact pad is divided into two separate pads, as this has been shown to improve solder joint quality.

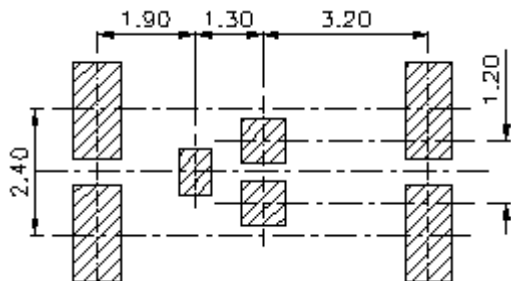

(dimensions in mm)

Figure A.18.2(a) M2-outline substrate/PCB layout

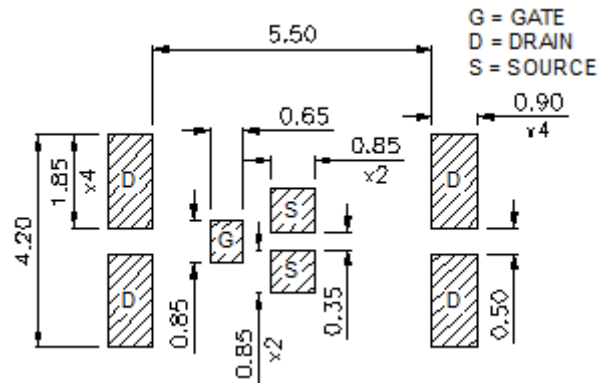

(dimensions in mm)

Figure A.18.2(b) M2-outline substrate/PCB layout

### Stencil design

Evaluations have shown that the best overall performance is achieved using the stencil design shown in Figure A.18.3 (a and b)

Note: This design is for a stencil thickness of 0.150mm (0.006"). The reduction should be adjusted for stencils of other thicknesses.

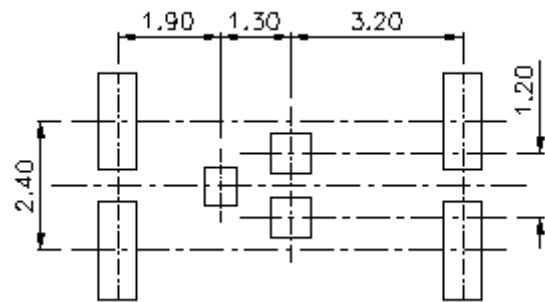

(dimensions in mm)

Figure A.18.3(a) M2-outline stencil design

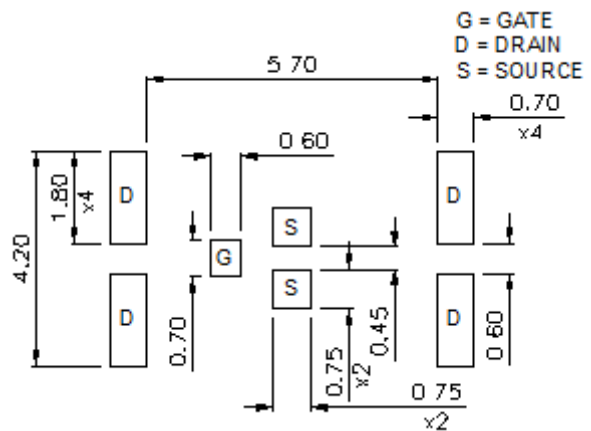

(dimensions in mm)

Figure A.18.3(b) M2-outline stencil design

## Appendix A.19 M4-outline

### Device outline

Figure A.19.1 shows the outline for M4-outline DirectFET devices. The relative pad positions are controlled to an accuracy of  $\pm 0.065\text{mm}$ . For full dimensions and tolerances of each device, and to find out its size and outline, refer to the relevant product data sheet and package outline drawing.

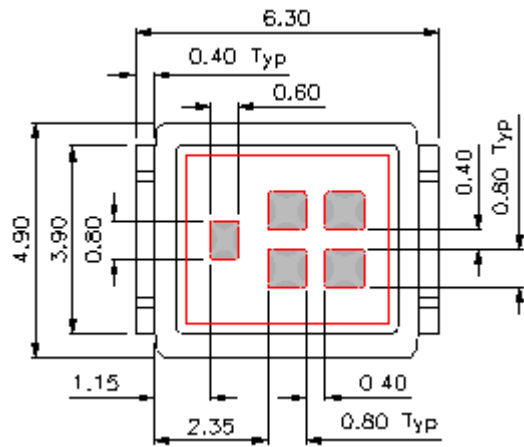

(dimensions in mm)

Figure A.19.1 M4-outline device outline

### Substrate/PCB layout

Evaluations have shown that the best overall performance is achieved using the substrate/PCB layout shown in Figure A.19.2 (a and b). Gate and source pads on the substrate are oversized by 0.025mm (0.001") on each side. Drain pads are thickened by 0.500mm (0.020"). Each drain contact pad is divided into two separate pads, as this has been shown to improve solder joint quality.

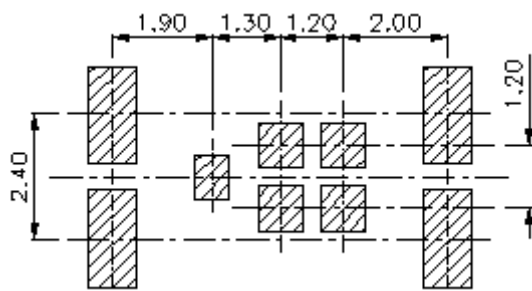

(dimensions in mm)

Figure A.19.2(a) M4-outline substrate/PCB layout

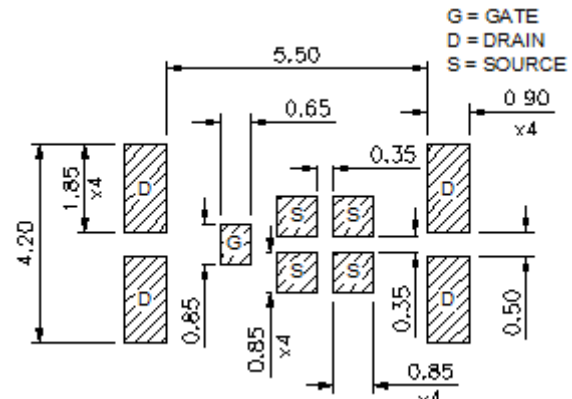

(dimensions in mm)

Figure A.19.2(b) M4-outline substrate/PCB layout

### Stencil design

Evaluations have shown that the best overall performance is achieved using the stencil design shown in Figure A.19.3 (a and b)

Note: This design is for a stencil thickness of 0.150mm (0.006"). The reduction should be adjusted for stencils of other thicknesses.

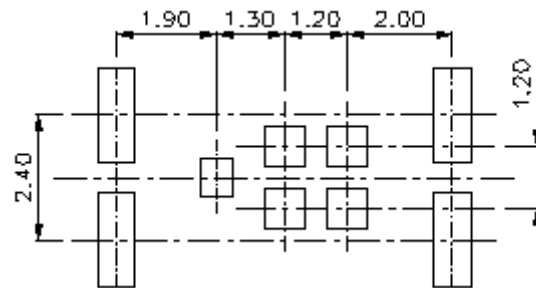

(dimensions in mm)

Figure A.19.3(a) M4-outline stencil design

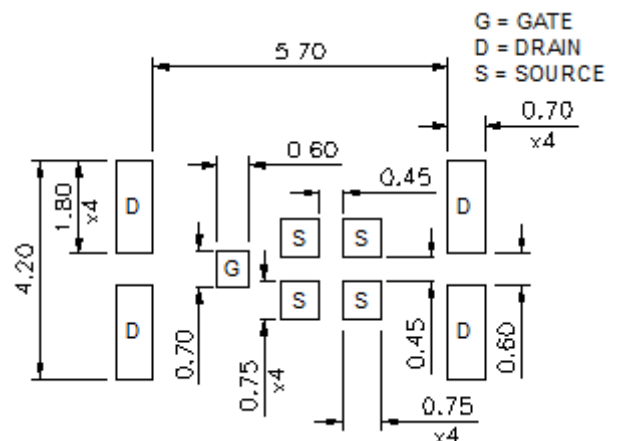

(dimensions in mm)

Figure A.19.3(b) M4-outline stencil design

## Appendix A.20 MA-outline

### Device outline

Figure A.20.1 shows the outline for MA-outline DirectFET devices. The relative pad positions are controlled to an accuracy of  $\pm 0.065\text{mm}$ . For full dimensions and tolerances of each device, and to find out its size and outline, refer to the relevant product data sheet and package outline drawing.

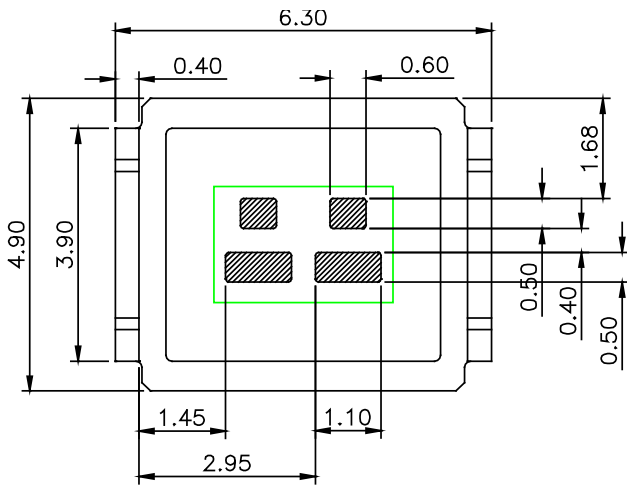

(dimensions in mm)

Figure A.20.1 MA-outline device outline

### Substrate/PCB layout

Evaluations have shown that the best overall performance is achieved using the substrate/PCB layout shown in Figure A.20.2 (a and b). Gate and source pads on the substrate are oversized by  $0.025\text{mm}$  ( $0.001''$ ) on each side. Drain pads are thickened by  $0.500\text{mm}$  ( $0.020''$ ). Each drain contact pad is divided into three separate pads, as this has been shown to improve solder joint quality.

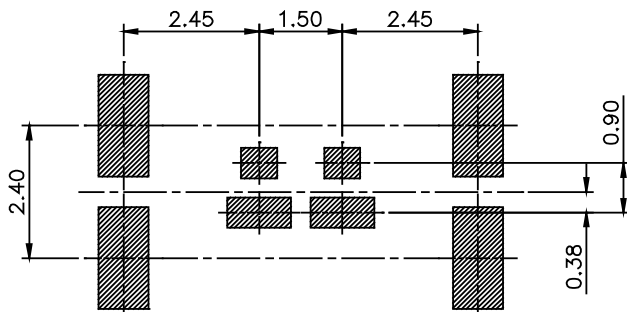

(dimensions in mm)

Figure A.20.2(a) MA-outline substrate/PCB layout

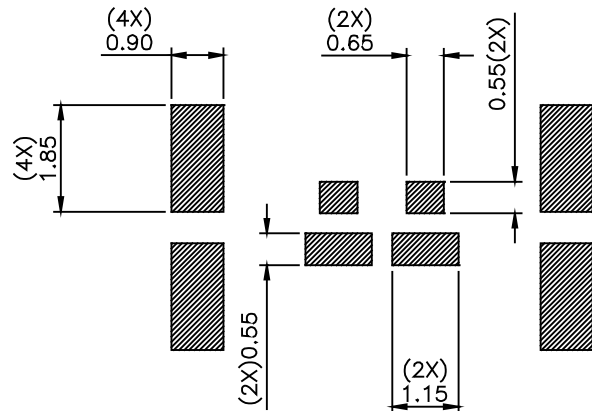

(dimensions in mm)

Figure A.20.2(b) MA-outline substrate/PCB layout

### Stencil design

Evaluations have shown that the best overall performance is achieved using the stencil design shown in Figure A.20.3 (a and b)

Note: This design is for a stencil thickness of  $0.150\text{mm}$  ( $0.006''$ ). The reduction should be adjusted for stencils of other thicknesses.

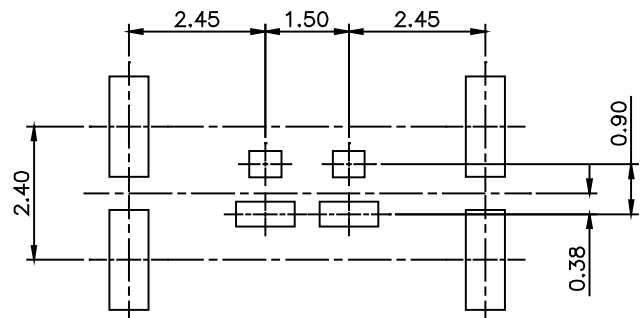

(dimensions in mm)

Figure A.20.3(a) MA-outline stencil design

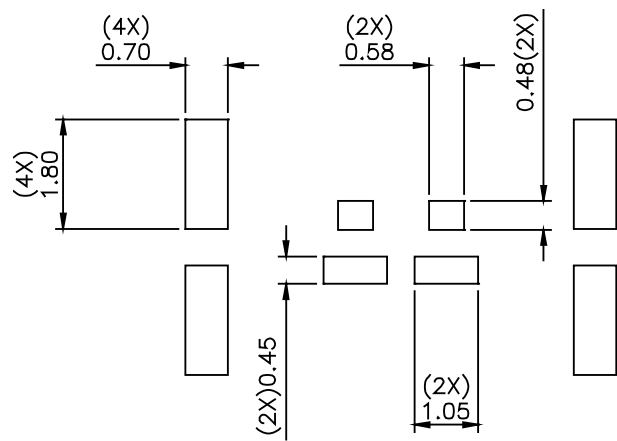

(dimensions in mm)

Figure A.20.3(b) MA-outline stencil design



## Appendix A.21 MB-outline

### Device outline

Figure A.21.1 shows the outline for MB-outline DirectFET devices. The relative pad positions are controlled to an accuracy of  $\pm 0.065\text{mm}$ . For full dimensions and tolerances of each device, and to find out its size and outline, refer to the relevant product data sheet and package outline drawing.

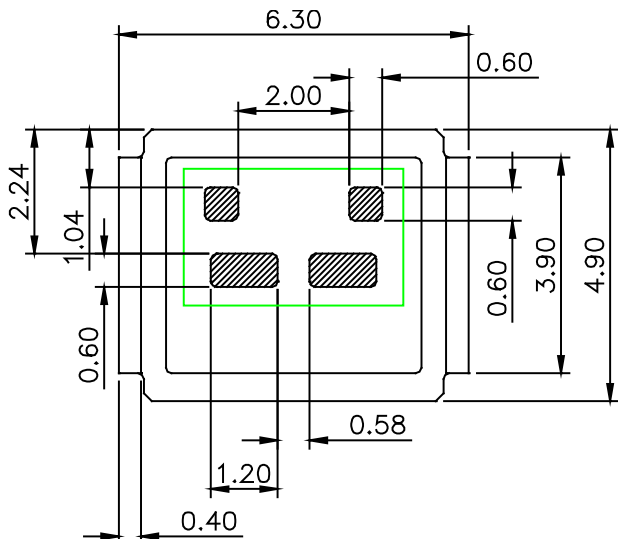

(dimensions in mm)

Figure A.21.1 MB-outline device outline

### Substrate/PCB layout

Evaluations have shown that the best overall performance is achieved using the substrate/PCB layout shown in Figure A.21.2 (a and b). Gate and source pads on the substrate are oversized by  $0.025\text{mm}$  ( $0.001''$ ) on each side. Drain pads are thickened by  $0.500\text{mm}$  ( $0.020''$ ). Each drain contact pad is divided into three separate pads, as this has been shown to improve solder joint quality.

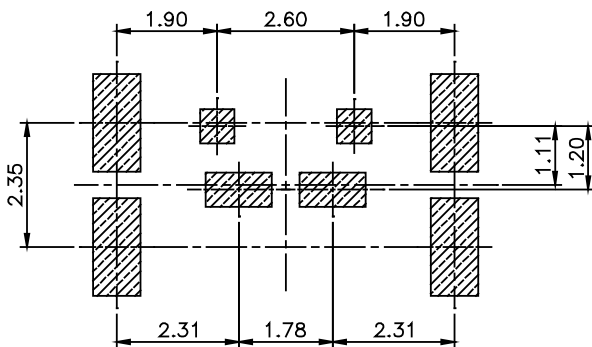

(dimensions in mm)

Figure A.21.2(a) MB-outline substrate/PCB layout

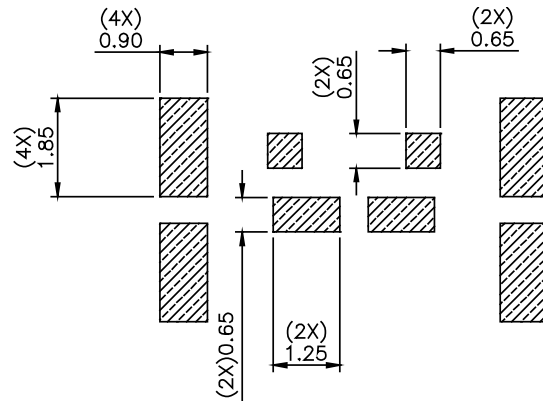

(dimensions in mm)

Figure A.21.2(b) MB-outline substrate/PCB layout

### Stencil design

Evaluations have shown that the best overall performance is achieved using the stencil design shown in Figure A.21.3 (a and b)

Note: This design is for a stencil thickness of  $0.150\text{mm}$  ( $0.006''$ ). The reduction should be adjusted for stencils of other thicknesses.

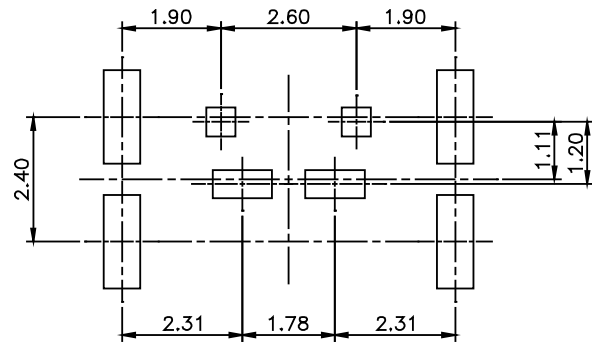

(dimensions in mm)

Figure A.21.3(a) MB-outline stencil design

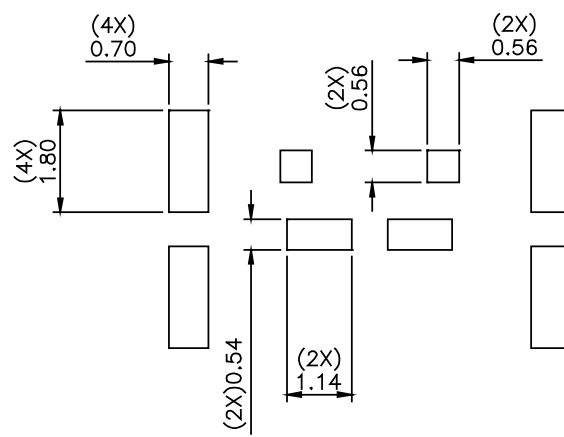

(dimensions in mm)

Figure A.21.3(b) MB-outline stencil design

## Appendix A.22 MC-outline

### Device outline

Figure A.22.1 shows the outline for MC-outline DirectFET devices. The relative pad positions are controlled to an accuracy of  $\pm 0.065\text{mm}$ . For full dimensions and tolerances of each device, and to find out its size and outline, refer to the relevant product data sheet and package outline drawing

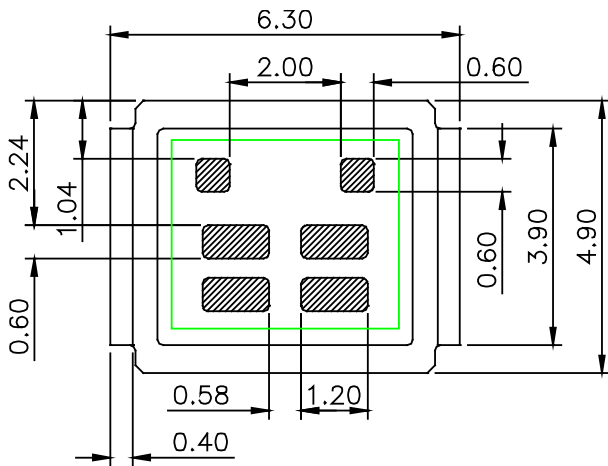

(dimensions in mm)

Figure A.22.1 MC-outline device outline

### Substrate/PCB layout

Evaluations have shown that the best overall performance is achieved using the substrate/PCB layout shown in Figure A.22.2 (a and b). Gate and source pads on the substrate are oversized by 0.025mm (0.001") on each side. Drain pads are thickened by 0.500mm (0.020"). Each drain contact pad is divided into three separate pads, as this has been shown to improve solder joint quality.

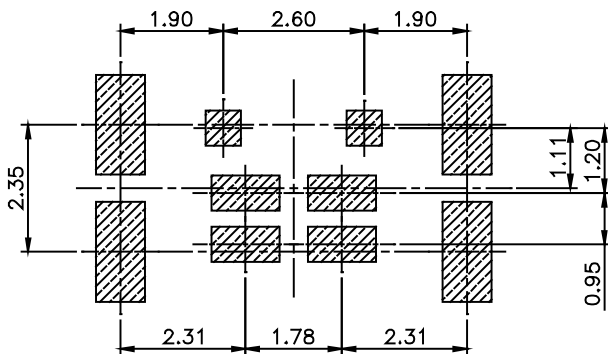

(dimensions in mm)

Figure A.22.2(a) MC-outline substrate/PCB layout

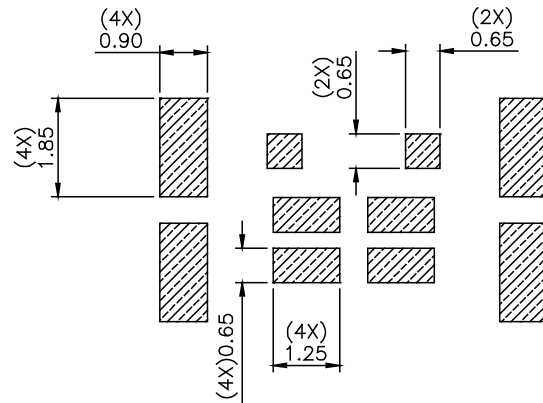

(dimensions in mm)

Figure A.22.2(b) MC-outline substrate/PCB layout

### Stencil design

Evaluations have shown that the best overall performance is achieved using the stencil design shown in Figure A.22.3 (a and b)

Note: This design is for a stencil thickness of 0.150mm (0.006"). The reduction should be adjusted for stencils of other thicknesses.

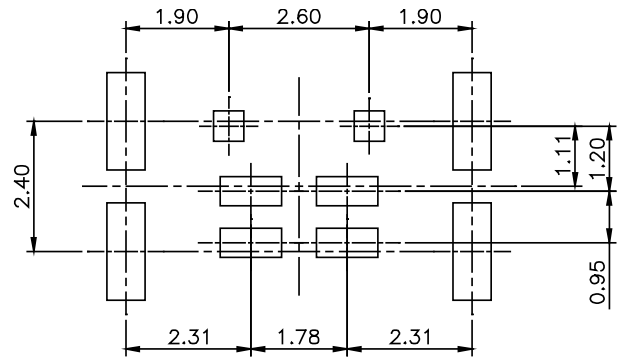

(dimensions in mm)

Figure A.22.3(a) MC-outline stencil design

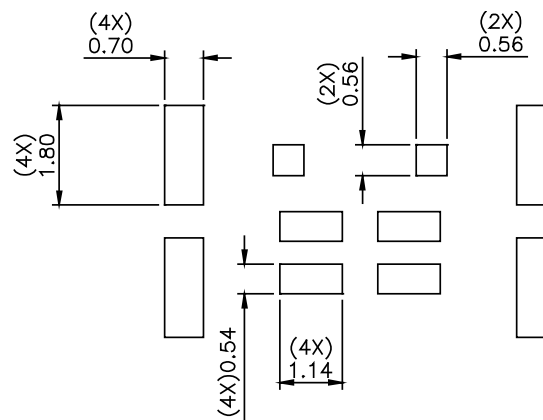

(dimensions in mm)

Figure A.22.3(b) MC-outline stencil design

## Appendix A.23 MD-outline

### Device outline

Figure A.23.1 shows the outline for MD-outline DirectFET devices. The relative pad positions are controlled to an accuracy of  $\pm 0.065\text{mm}$ . For full dimensions and tolerances of each device, and to find out its size and outline, refer to the relevant product data sheet and package outline drawing

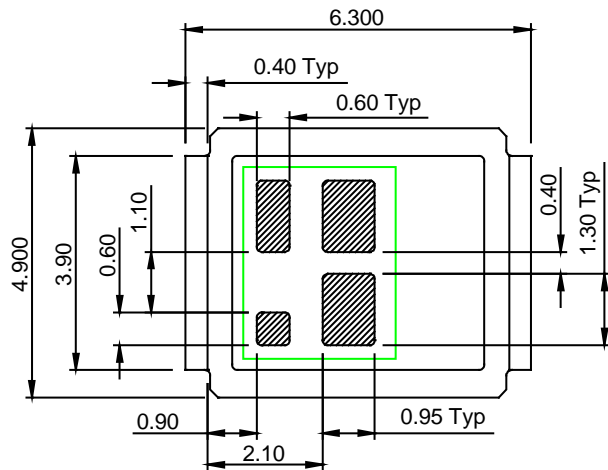

(dimensions in mm)

Figure A.23.1 MD-outline device outline

### Substrate/PCB layout

Evaluations have shown that the best overall performance is achieved using the substrate/PCB layout shown in Figure A.23.2 (a and b). Gate and source pads on the substrate are oversized by 0.025mm (0.001") on each side. Drain pads are thickened by 0.500mm (0.020"). Each drain contact pad is divided into three separate pads, as this has been shown to improve solder joint quality.

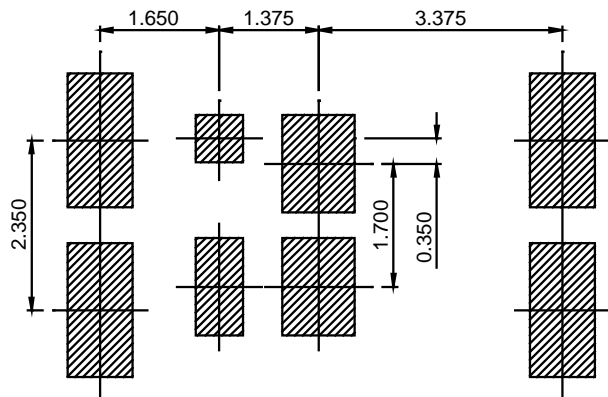

(dimensions in mm)

Figure A.23.2(a) MD-outline substrate/PCB layout

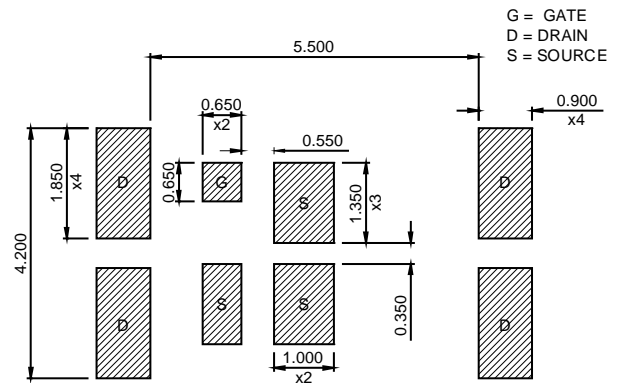

(dimensions in mm)

Figure A.23.2(b) MD-outline substrate/PCB layout

### Stencil design

Evaluations have shown that the best overall performance is achieved using the stencil design shown in Figure A.23.3 (a and b)

Note: This design is for a stencil thickness of 0.150mm (0.006"). The reduction should be adjusted for stencils of other thicknesses.

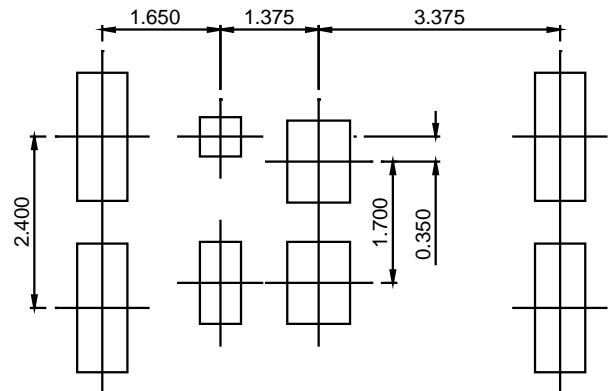

(dimensions in mm)

Figure A.23.3(a) MD-outline stencil design

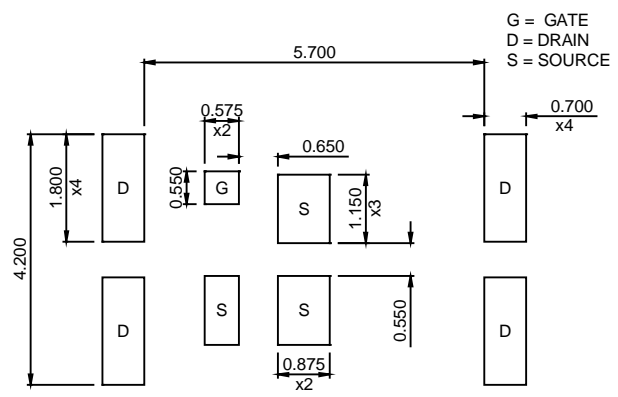

(dimensions in mm)

Figure A.23.3(b) MD-outline stencil design

## Appendix A.24 ME-outline

### Device outline

Figure A.24.1 shows the outline for ME-outline DirectFET devices. The relative pad positions are controlled to an accuracy of  $\pm 0.065\text{mm}$ . For full dimensions and tolerances of each device, and to find out its size and outline, refer to the relevant product data sheet and package outline drawing

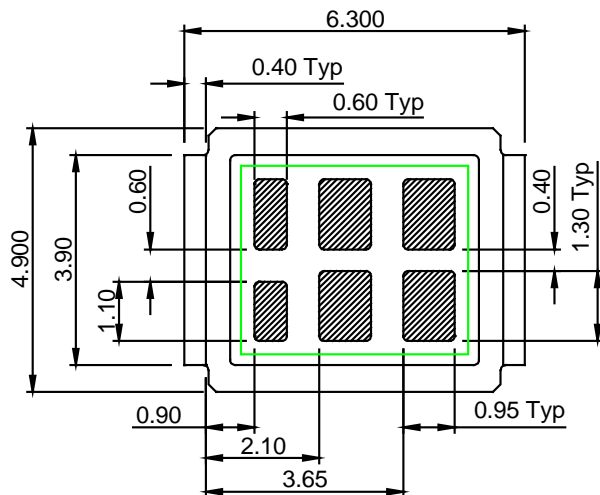

(dimensions in mm)

Figure A.24.1 ME-outline device outline

### Substrate/PCB layout

Evaluations have shown that the best overall performance is achieved using the substrate/PCB layout shown in Figure A.24.2 (a and b). Gate and source pads on the substrate are oversized by 0.025mm (0.001") on each side. Drain pads are thickened by 0.500mm (0.020"). Each drain contact pad is divided into three separate pads, as this has been shown to improve solder joint quality.

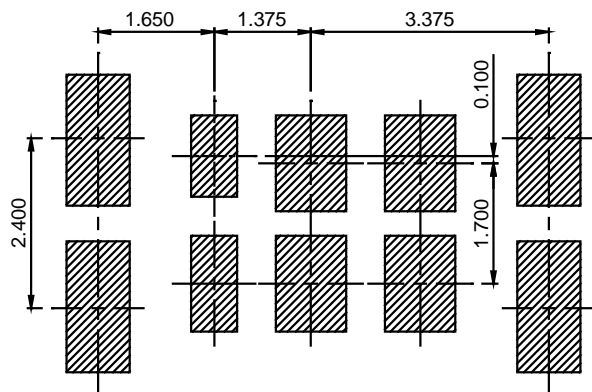

(dimensions in mm)

Figure A.24.2(a) ME-outline substrate/PCB layout

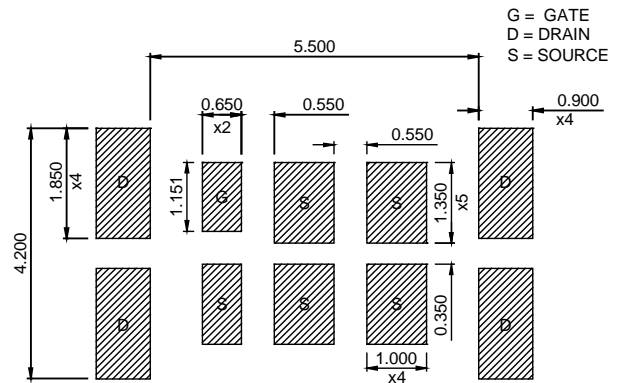

(dimensions in mm)

Figure A.24.2(b) ME-outline substrate/PCB layout

### Stencil design

Evaluations have shown that the best overall performance is achieved using the stencil design shown in Figure A.24.3 (a and b)

Note: This design is for a stencil thickness of 0.150mm (0.006"). The reduction should be adjusted for stencils of other thicknesses.

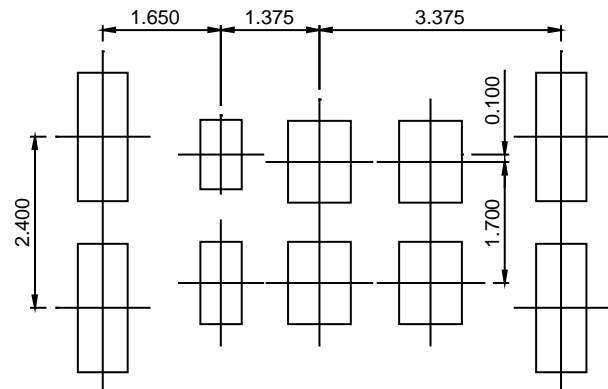

(dimensions in mm)

Figure A.24.3(a) ME-outline stencil design

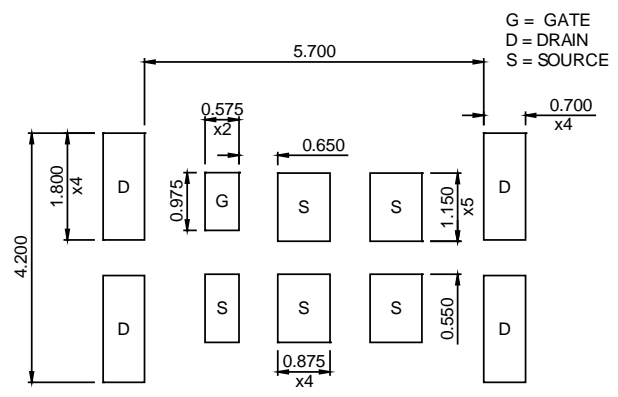

(dimensions in mm)

Figure A.24.3(b) ME-outline stencil design

## Appendix A.25 MF-outline

### Device outline

Figure A.25.1 shows the outline for MF-outline DirectFET devices. The relative pad positions are controlled to an accuracy of  $\pm 0.065\text{mm}$ . For full dimensions and tolerances of each device, and to find out its size and outline, refer to the relevant product data sheet and package outline drawing

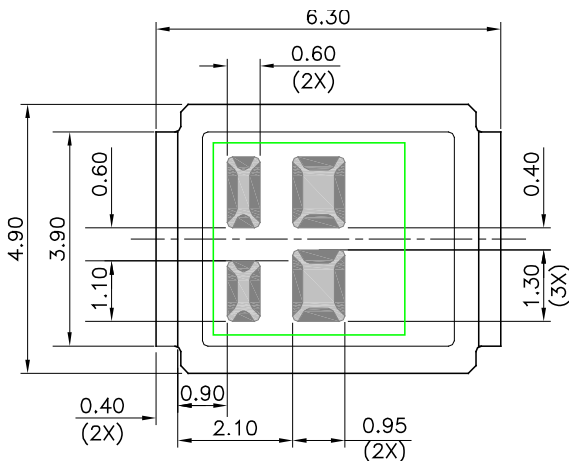

(dimensions in mm)

Figure A.25.1 MF-outline device outline

### Substrate/PCB layout

Evaluations have shown that the best overall performance is achieved using the substrate/PCB layout shown in Figure A.25.2 (a and b). Gate and source pads on the substrate are oversized by 0.025mm (0.001") on each side. Drain pads are thickened by 0.500mm (0.020"). Each drain contact pad is divided into three separate pads, as this has been shown to improve solder joint quality.

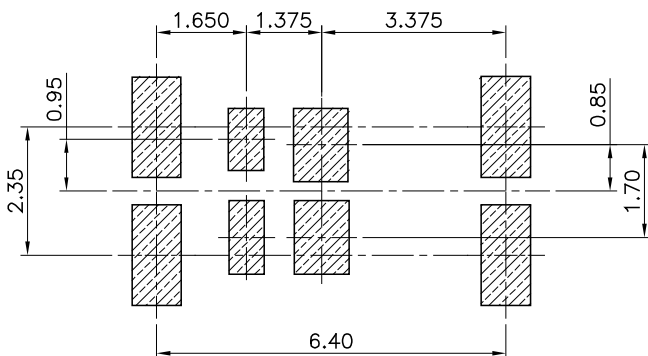

(dimensions in mm)

Figure A.25.2(a) MF-outline substrate/PCB layout

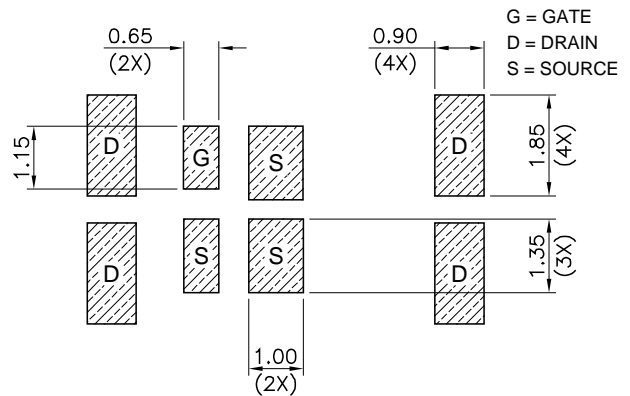

(dimensions in mm)

Figure A.25.2(b) MF-outline substrate/PCB layout

### Stencil design

Evaluations have shown that the best overall performance is achieved using the stencil design shown in Figure A.25.3 (a and b)

Note: This design is for a stencil thickness of 0.150mm (0.006"). The reduction should be adjusted for stencils of other thicknesses.

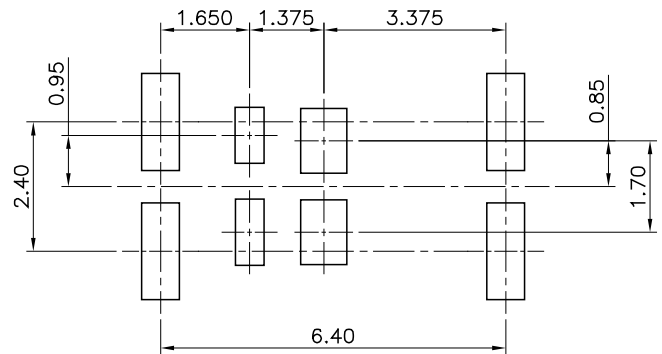

(dimensions in mm)

Figure A.25.3(a) MF-outline stencil design

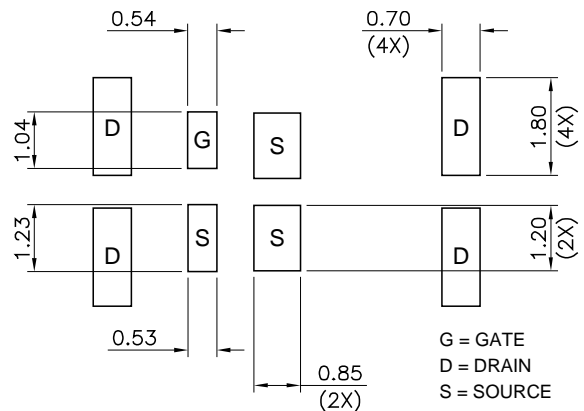

(dimensions in mm)

Figure A.25.3(b) MF-outline stencil design



## Appendix A.26 L4-outline

### Device outline

Figure A.26.1 shows the outline for L4-outline DirectFET devices. The relative pad positions are controlled to an accuracy of  $\pm 0.065\text{mm}$ . For full dimensions and tolerances of each device, and to find out its size and outline, refer to the relevant product data sheet and package outline drawing.

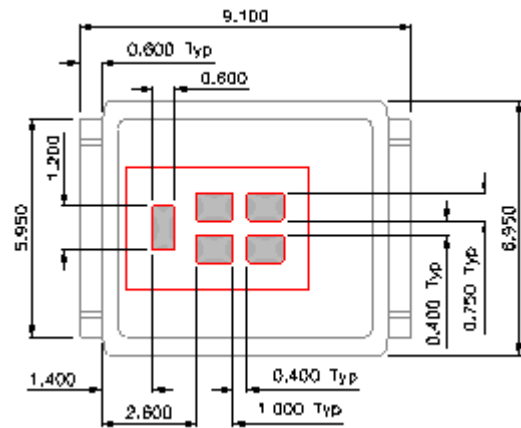

(dimensions in mm)

Figure A.26.1 L4-outline device outline

### Substrate/PCB layout

Evaluations have shown that the best overall performance is achieved using the substrate/PCB layout shown in Figure A.26.2 (a and b). Gate and source pads on the substrate are oversized by 0.025mm (0.001") on each side. Drain pads are thickened by 0.500mm (0.020"). Each drain contact pad is divided into three separate pads, as this has been shown to improve solder joint quality.

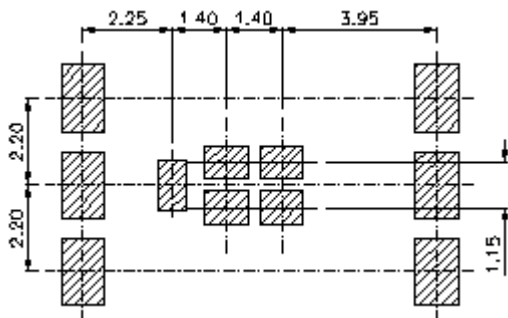

(dimensions in mm)

Figure A.26.2(a) L4-outline substrate/PCB layout

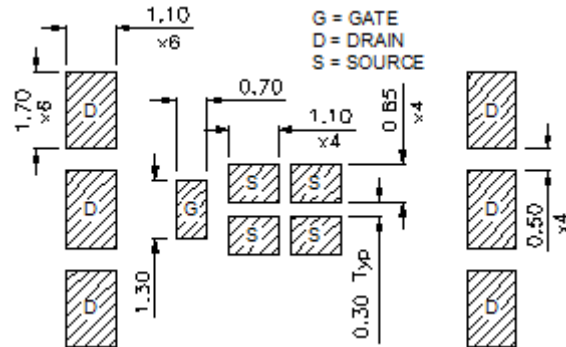

(dimensions in mm)

Figure A.26.2(b) L4-outline substrate/PCB layout

### Stencil design

Evaluations have shown that the best overall performance is achieved using the stencil design shown in Figure A.26.3 (a and b)

Note: This design is for a stencil thickness of 0.150mm (0.006"). The reduction should be adjusted for stencils of other thicknesses.

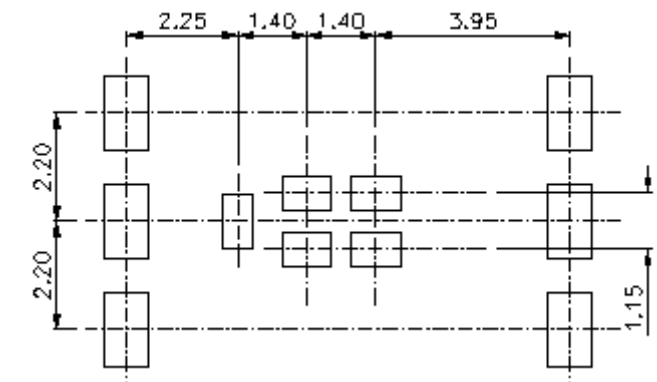

(dimensions in mm)

Figure A.26.3(a) L4-outline stencil design

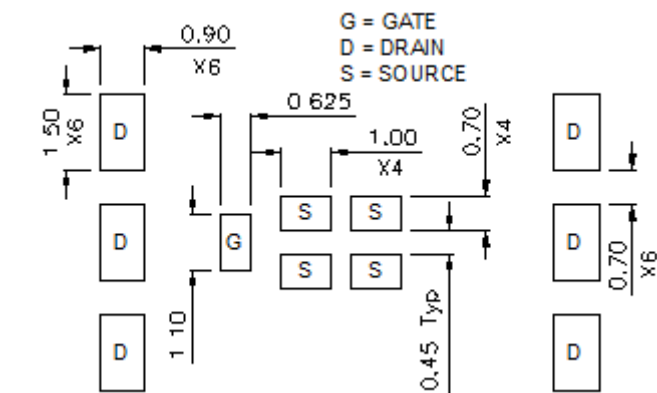

(dimensions in mm)

Figure A.26.3(b) L4-outline stencil design

## Appendix A.27 L6-outline

### Device outline

Figure A.27.1 shows the outline for L6-outline DirectFET devices. The relative pad positions are controlled to an accuracy of  $\pm 0.065\text{mm}$ . For full dimensions and tolerances of each device, and to find out its size and outline, refer to the relevant product data sheet and package outline drawing.

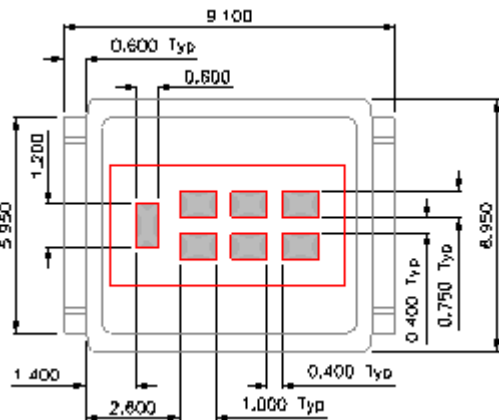

(dimensions in mm)

Figure A.27.1 L6-outline device outline

### Substrate/PCB layout

Evaluations have shown that the best overall performance is achieved using the substrate/PCB layout shown in Figure A.27.2 (a and b). Gate and source pads on the substrate are oversized by 0.025mm (0.001") on each side. Drain pads are thickened by 0.500mm (0.020"). Each drain contact pad is divided into three separate pads, as this has been shown to improve solder joint quality.

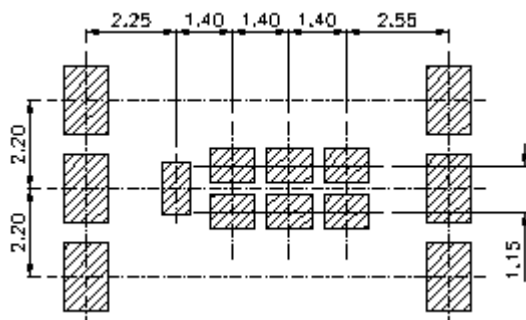

(dimensions in mm)

Figure A.27.2(a) L6-outline substrate/PCB layout

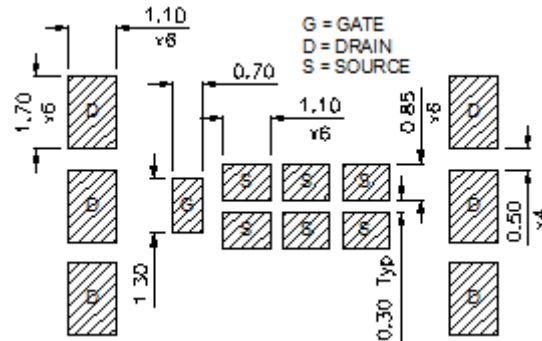

(dimensions in mm)

Figure A.27.2(b) L6-outline substrate/PCB layout

### Stencil design

Evaluations have shown that the best overall performance is achieved using the stencil design shown in Figure A.27.3 (a and b)

Note: This design is for a stencil thickness of 0.150mm (0.006"). The reduction should be adjusted for stencils of other thicknesses.

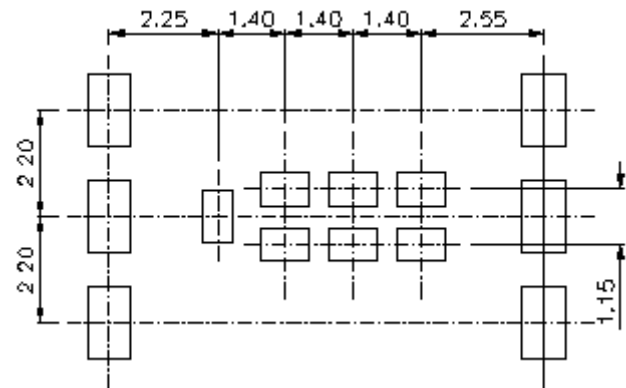

(dimensions in mm)

Figure A.27.3(a) L6-outline stencil design

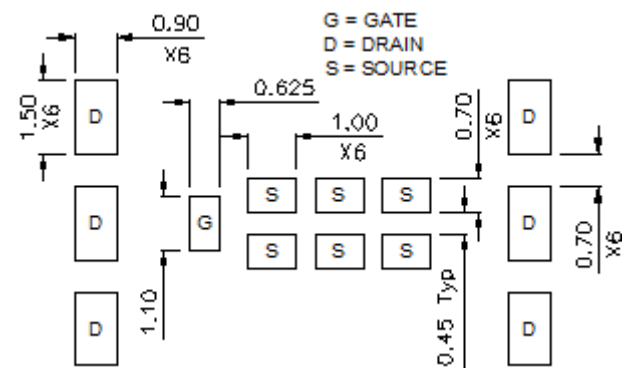

(dimensions in mm)

Figure A.27.3(b) L6-outline stencil design

## Appendix A.28 L8-outline

### Device outline

Figure A.28.1 shows the outline for L8-outline DirectFET devices. The relative pad positions are controlled to an accuracy of  $\pm 0.065\text{mm}$ . For full dimensions and tolerances of each device, and to find out its size and outline, refer to the relevant product data sheet and package outline drawing

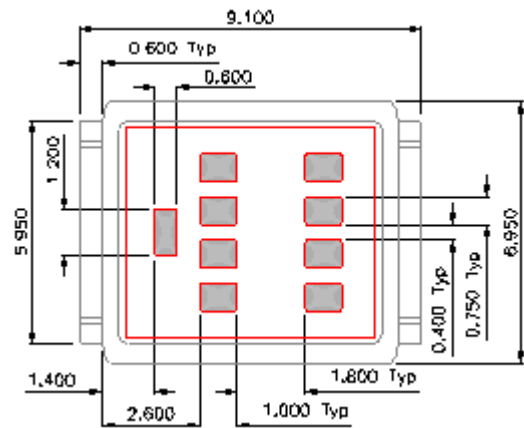

(dimensions in mm)

Figure A.28.1 L8-outline device outline

### Substrate/PCB layout

Evaluations have shown that the best overall performance is achieved using the substrate/PCB layout shown in Figure A.28.2 (a and b). Gate and source pads on the substrate are oversized by 0.025mm (0.001") on each side. Drain pads are thickened by 0.500mm (0.020"). Each drain contact pad is divided into three separate pads, as this has been shown to improve solder joint quality.

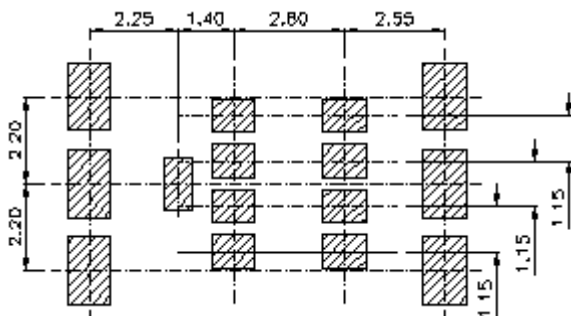

(dimensions in mm)

Figure A.28.2(a) L8-outline substrate/PCB layout

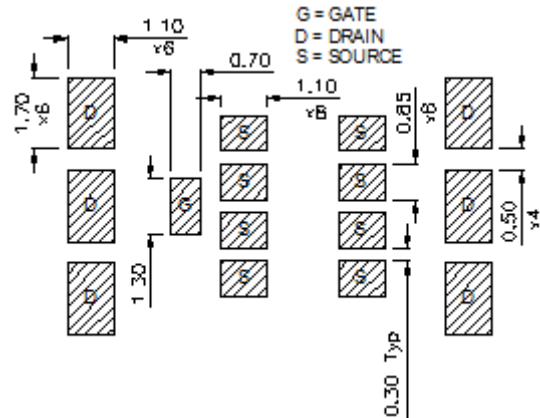

(dimensions in mm)

Figure A.28.2(b) L8-outline substrate/PCB layout

### Stencil design

Evaluations have shown that the best overall performance is achieved using the stencil design shown in Figure A.28.3 (a and b)

Note: This design is for a stencil thickness of 0.150mm (0.006"). The reduction should be adjusted for stencils of other thicknesses.

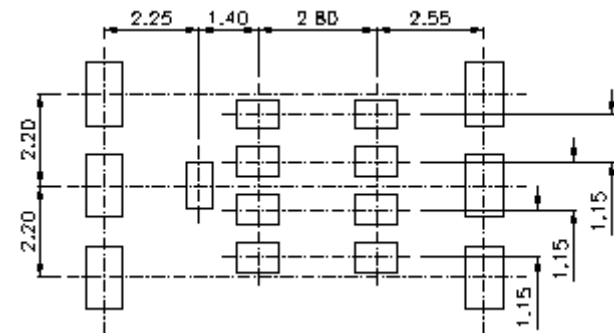

(dimensions in mm)

Figure A.28.3(a) L8-outline stencil design

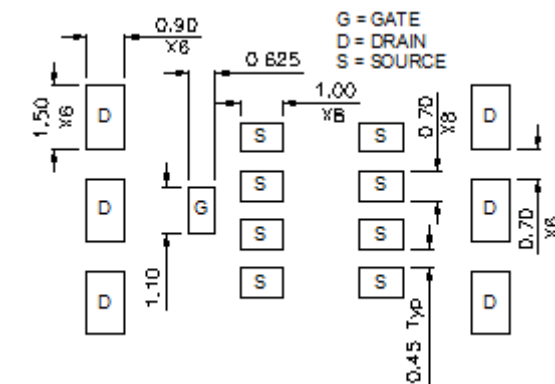

(dimensions in mm)

Figure A.28.3(b) L8-outline stencil design

## Appendix A.26 LA-outline

### Device outline

Figure A.26.1 shows the outline for LA-outline DirectFET devices. The relative pad positions are controlled to an accuracy of  $\pm 0.065\text{mm}$ . For full dimensions and tolerances of each device, and to find out its size and outline, refer to the relevant product data sheet and package outline drawing.

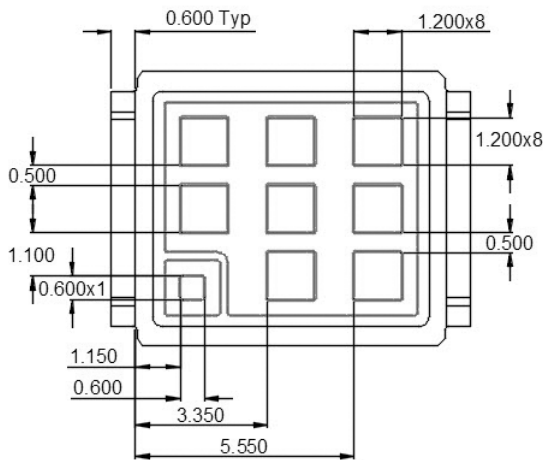

(dimensions in mm)

Figure A.26.1 LA-outline device outline

### Substrate/PCB layout

Evaluations have shown that the best overall performance is achieved using the substrate/PCB layout shown in Figure A.26.2 (a and b). Gate and source pads on the substrate are oversized by 0.025mm (0.001") on each side. Drain pads are thickened by 0.500mm (0.020"). Each drain contact pad is divided into three separate pads, as this has been shown to improve solder joint quality.

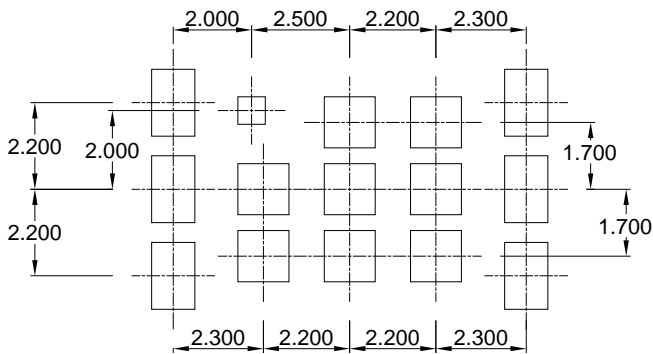

(dimensions in mm)

Figure A.26.2(a) LA-outline substrate/PCB layout

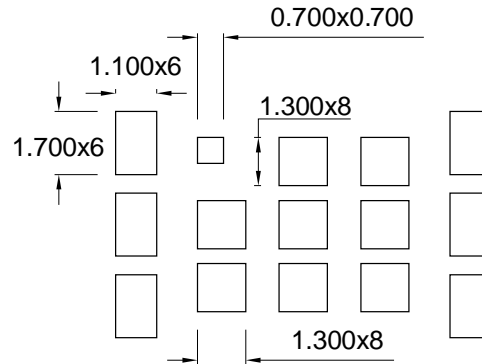

(dimensions in mm)

Figure A.26.2(b) LA-outline substrate/PCB layout

### Stencil design

Evaluations have shown that the best overall performance is achieved using the stencil design shown in Figure A.26.3 (a and b)

Note: This design is for a stencil thickness of 0.150mm (0.006"). The reduction should be adjusted for stencils of other thicknesses.

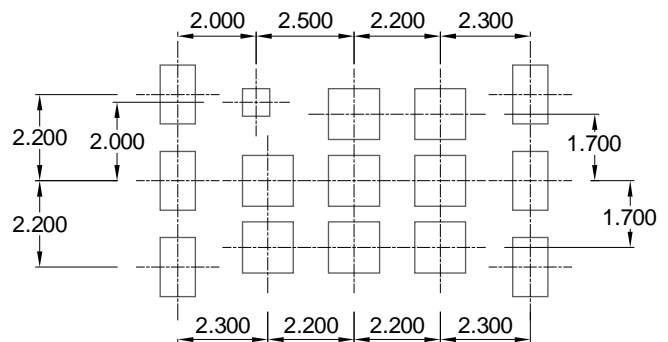

(dimensions in mm)

Figure A.26.3(a) LA-outline stencil design

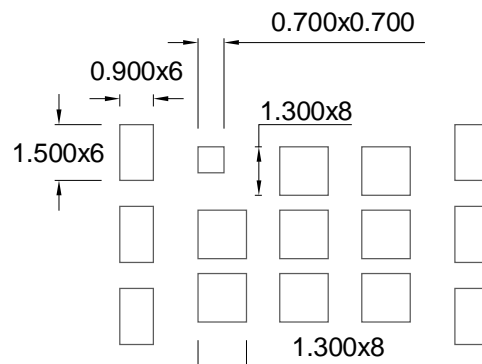

(dimensions in mm)

Figure A.26.3(b) LA-outline stencil design