

SERVICE MANUAL

US Model
 Canadian Model
 AEP Model
 UK Model
 E Model



Discman

Model Name Using Similar Mechanism	D-9/90
CD Mechanism Type	CDM-90

SPECIFICATIONS

CD section

System
 Laser diode properties

Compact disc digital audio system
 Material: GaAlAs
 Wavelength: 780 nm
 Emission duration: Continuous
 Laser output: Less than 44.6 μ W*
 *This output is the value measured at a distance of 200 mm from the objective lens surface on the Optical Pick-up Block.

Spindle speed
 Scan velocity
 Error correction
 D-A conversion
 Frequency response
 Wow and flutter
 Outputs (at 9 V input level)

500 r.p.m. to 200 r.p.m. (CLV)
 1.2-1.4 m/sec.
 Sony Super Strategy Cross Interleave Reed Solomon Code
 1-bit quartz time-axis control
 20-20,000 Hz ± 1 dB
 Below measurable limit**
 Line output (stereo minijack)
 Output level 1.0 V rms at 50 kilohms
 Load impedance over 10 kilohms
 Headphones (stereo minijack)
 9mW + 9 mW at 16 ohms

**Measured by EIAJ CP-307

General

Power requirements

Rechargeable battery pack BP-2EX (supplied)
 Battery case EBP-2 (supplied) and two size AA (LR6) alkaline batteries (optional)
 DC IN 9 V jack accepts:
 Sony AC power adaptor (supplied)

— Continued on page 2 —

CAUTION

Use of controls or adjustments or performance of procedures other than those specified herein may result in hazardous radiation exposure.

COMPACT DISC COMPACT PLAYER

SONY®

Power consumption	2.6 W DC
Dimensions	Approx. 130.0 × 31.1 × 142.0 mm (5 ¹ / ₈ × 1 ¹ / ₄ × 5 ⁵ / ₈ in.) (w/h/d) not incl. Inclined part (depth), projecting parts and controls Approx. 131.0 × 32.4 × 142.7 mm (5 ¹ / ₄ × 1 ⁵ / ₈ × 5 ⁵ / ₈ in.) (w/h/d) incl. projecting parts and controls
Weight	Approx. 420 g (15 oz) not incl. rechargeable battery
Supplied accessories	Approx. 500 g (1 lb 1 oz) incl. rechargeable battery AC power adaptor (1), Battery case (1) Rechargeable battery pack (1), Carrying case (1) Connecting cord (1) (stereo miniplug ↔ two phono plugs) Stereo headphones (1)

Design and specifications subject to change without notice.

TABLE OF CONTENTS

<u>Section</u>	<u>Title</u>	<u>Page</u>
Specifications		1
1. GENERAL		2
2. SERVICING NOTES		3
Befor Replacing the Optical Block		3
Note on Laser Diode Emission Check		4
Laser Diode Check Procedure		4
Service Mode (service program)		4
Explanation of Terminals (IC301 CXD8178Q)		5
3. ELECTRICAL ADJUSTMENTS		6
4. DIAGRAMS		
4-1. Block Diagrams		9
4-2. PC Board/Switch/Motor Layouts		11
4-3. Semiconductor Lead Layouts		12
4-4. Printed Wiring Boards		14
4-5. Schematic Diagrams		19
4-6. IC Block Diagrams		22
5. EXPLODED VIEWS		24
6. ELECTRICAL PARTS LIST		26

SECTION 1 GENERAL

LOCATION AND FUNCTION OF CONTROLS

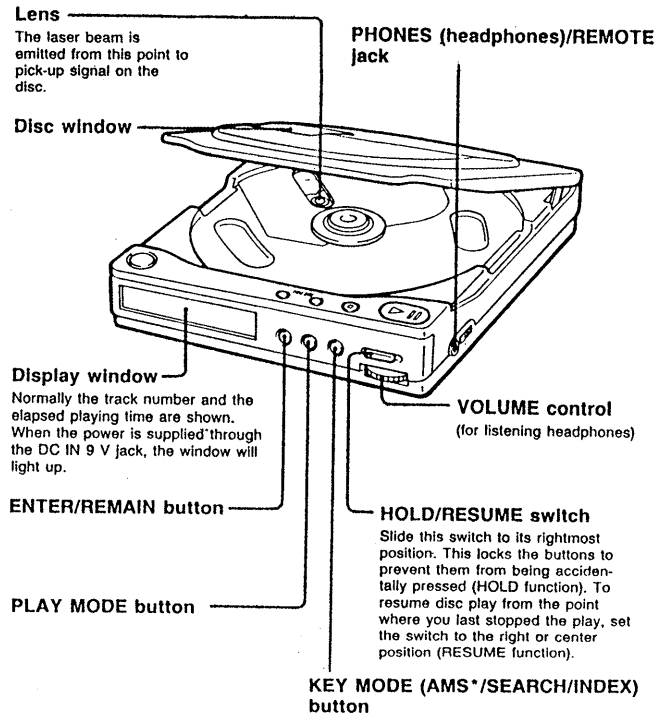

* AMS is the abbreviation of Auto Music Sensor.

SAFETY-RELATED COMPONENT WARNING!!

COMPONENTS IDENTIFIED BY MARK OR DOTTED LINE WITH MARK ON THE SCHEMATIC DIAGRAMS AND IN THE PARTS LIST ARE CRITICAL TO SAFE OPERATION. REPLACE THESE COMPONENTS WITH SONY PARTS WHOSE PART NUMBERS APPEAR AS SHOWN IN THIS MANUAL OR IN SUPPLEMENTS PUBLISHED BY SONY.

ATTENTION AU COMPOSANT AYANT RAPPORT À LA SÉCURITÉ!

LES COMPOSANTS IDENTIFIÉS PAR UNE MARQUE SUR LES DIAGRAMMES SCHÉMATIQUES ET LA LISTE DES PIÈCES SONT CRITIQUES POUR LA SÉCURITÉ DE FONCTIONNEMENT. NE REMPLACER CES COMPOSANTS QUE PAR DES PIÈCES SONY DONT LES NUMÉROS SONT DONNÉS DANS CE MANUEL OU DANS LES SUPPLÉMENTS PUBLIÉS PAR SONY.

SECTION 2

SERVICING NOTES

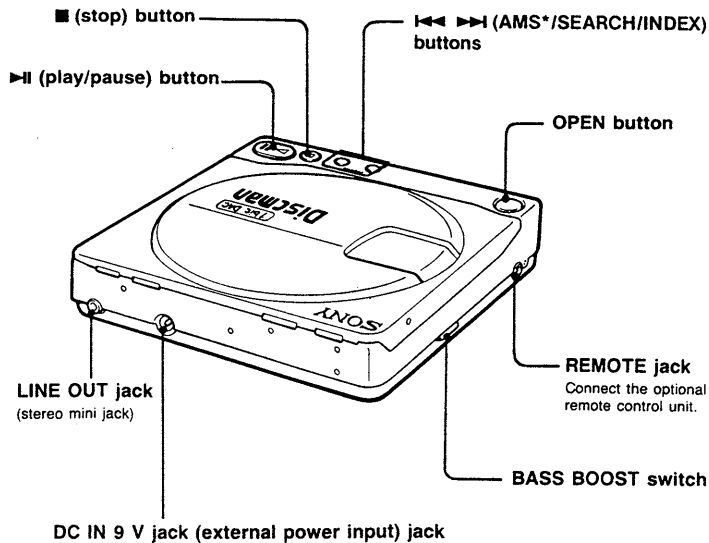

NOTES ON HANDLING THE OPTICAL PICK-UP BLOCK OR BASE UNIT

The laser diode in the optical pick-up block may suffer electrostatic breakdown because of the potential difference generated by the charged electrostatic load, etc. on clothing and the human body.

During repair, pay attention to electrostatic breakdown and also use the procedure in the printed matter which is included in the repair parts.

The flexible board is easily damaged and should be handled with care.

Before Replacing the Optical Block

Please be sure to check thoroughly the parameters as per the "Optical Block Checking Procedures" (Part No. : 9-960-027-11) issued separately before replacing the optical block. Note and specifications required to check are given below.

- FOK output : IC501⑨ pin
When checking FOK, remove the lead wire to spindle motor and unsolder and open IC801⑭ pin (FOK).
- S carve P-to-P value : 3Vp-p
When checking S carve P-to-P value, remove the lead wire to spindle motor.
- Adjusted part for focus gain adjustment : RV505
- RF signal P-to-P value : 0.7 – 1.25Vp-p
- Traverse signal P-to-P value : 1.5Vp-p
- The repairing grating holder is impossible.
- Adjusted part for tracking gain adjustment : RV501

Flexible Circuit Board Repairing

- Keep the temperature of the soldering iron around 270°C during repairing.
- Do not touch the soldering iron on the same conductor of the circuit board (within 3 times).
- Be careful not to apply force on the conductor when soldering or unsoldering.

Notes on chip component replacement

- Never reuse a disconnected chip component.
- Notice that the minus side of a tantalum capacitor may be damaged by heat.

NOTES ON LASER DIODE EMISSION CHECK

The laser beam on this model is concentrated so as to be focused on the disc reflective surface by the objective lens in the Optical pick-up block. Therefore, when checking the laser diode emission, observe more than 30cm away from the objective lens.

Laser Diode Check Procedure

The laser diode on this set will not emit unless the top panel is closed and S901 is turned on. The laser diode will always emit even if focus search is not performed in service mode.

Procedure 1 (service mode or normal operation)

Check the laser diode emission with the eye.

1. Open top panel.
2. Turn on S901 in Fig. 1.
(In service mode, this operation is not necessary.)
3. Press the ►|| key.
(In service mode, this operation is not necessary.)
4. Observe the objective lens and confirm that the laser diode is emitting light. At this time, the laser diode goes on about 10 seconds due to focus search.

Procedure 2 (service mode or normal operation)

Check by the current with flows in the laser diode.

1. Close the top panel.
2. Remove the main board and read the current value on the label affixed to the Optical pick-up block,

(Label on Optical pick-up block)

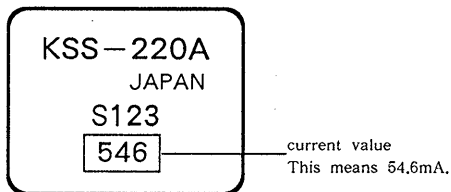

3. Connect a VOM to TP1 and TP2 (both side of R510 : 10 Ω)
4. Press the ►|| key.
5. Calculate the current by the VOM reading.
VOM reading (V) ÷ resistance of R510 = current (A)
ex. VOM reading = 0.56V
 $0.56 \div 10 = 0.056$ (A) = 56 (mA)
6. Confirm that the ammeter reading is within the range given below.
value on label ± 1 mA (25°C)
variation relative to temperature : 0.4mA/°C
(Current increases when temperature rises and decreases when it drops.)

SERVICE MODE (service program)

• Step 1 (Service Mode setting method)

1. Turn the HOLD switch to OFF with the external power supply not plugged in (no power applied to set).
2. Press the ►|| key.
3. Solder jumper TEST terminal.
(IC801 pin⑨ BAT-E is grounded.)
4. Plug in external power supply.
This puts the set into service mode.

• Step 2 (Service Mode operation)

1. When service mode is set, the display will change 6 times, and those 6 changes will be repeated over and over.
Even if LCD does not display, other operations will be performed.
2. When ►|| or ◀◀ key is pressed, the optical pick-up block moves to the inside or outside circumference. Tracking servo and sled servo go off when this is done, so press KEY-MODE to turn on the tracking servo if necessary.
3. When REMAIN is pressed, the display stops. When REMAIN is released, the display continues to change. This allows check of each segment.
4. When ►|| Key is pressed, CLV-S (pull-in mode) starts while performing focus search. When there is no disc installed, focus search is repeated with rotating disc motor.
5. When KEY-MODE is pressed, tracking servo, sled servo and CLV-A (servo during PLAY) go ON.
6. When 4 and 5 are performed, the disc begins to play. At this time, the top panel should be closed and S901 are to be ON. A sound is not produced as muting is ON.
7. All servo (focus, tracking, sled and spindle) go off when ■ key is pressed. Disc motor rotate by inertia for a some time.

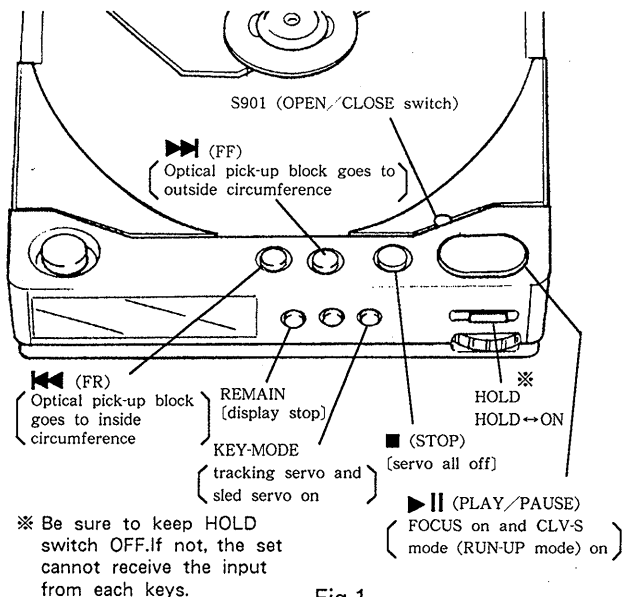

Fig.1

• Step 3 (Service Mode release)

1. First be sure to unplug the external power supply.
2. Then remove the solder jumper TEST terminal.
3. The set will now operated normally.

● Explanation of terminals (IC301 CXD8178Q)

Terminal No.	Name of terminal	Descriptions
1	MLD	Micro computer command load input (When L, load)
2	RSTB	Reset terminal (L : reset)
3	IE	When L : Signal processing LSI format When H : I ² S format
4	TP1	Digital filter part test output terminal 1
5	TP2	Digital filter part test output terminal 2
6	TEST 1	Test signal input terminal 1 for digital filter part inspection Normal : "L"
7	TEST 2	Test signal input terminal 2 for digital filter part inspection Normal : "L"
8	NC	_____
9	NC	_____
10	AV _{DD} 4	Analog system power terminal 4 (+3.9V)
11	OUTL (-)	L ch opposite phase PWM output terminal
12	AV _{SS} 4	Analog system ground terminal 4
13	AV _{SS} 3	Analog system ground terminal 3
14	OUTL (+)	L ch normal phase PWM output terminal
15	AV _{DD} 3	Analog system power terminal 3 (+3.9V)
16	NC	_____
17	AV _{DD} 2	Analog system power terminal 2 (+3.9V)
18	OUTR (+)	R ch normal phase PWM output terminal
19	AV _{SS} 2	Analog system ground terminal 2
20	AV _{SS} 1	Analog system ground terminal 1
21	OUTR (-)	R ch opposite phase PWM output terminal
22	AV _{DD} 1	Analog system power terminal 1 (+3.9V)
23	DV _{DD} 1	Digital system power terminal 1 (Power for oscillator)
24	DV _{SS} 1	Digital system ground terminal 1 (Ground for oscillator)
25	X2	Crystal oscillator terminal
26	X1	Crystal oscillator terminal (Outer clock input terminal)
27	NC	_____
28	DV _{DD} 2	Digital system power terminal 2 (+3.9V)
29	DV _{SS} 2	Digital system ground terminal 2
30	NSUB	Connect to D-VDD (Silicon circuit board electric potential fixing terminal)
31	ZFLGB	Zero input inspection output terminal (When zero inspection : L)
32	192FS	192FS (=8.4672MHz) output terminal
33	LRPOL	LRCLK polarity selection input terminal
34	LRCLK	LRCLK input terminal When LR-POL H, H : L ch data input • L : R ch data input When LR-POL L, L : L ch data input • H : R ch data input
35	BCLK	Serial input bit clock
36	SRDATA	Serial input data (digital) input terminal
37	DV _{SS} 3	Digital system ground terminal 3
38	DV _{DD}	Digital system ground terminal (COM electric potential fixing terminal) (+3.9V)
39	384FS	384FS (=16.9344MHz) output terminal
40	PD	Power down terminal (H : power down mode)
41	MDATA	Micro computer command data input terminal
42	MCLK	Clock input terminal for micro computer command

SECTION 3

ELECTRICAL ADJUSTMENTS

Notes on Adjustment

- Perform adjustments except for BATTERY REMAINS ADJUSTMENT in service mode.
Be sure to release service mode after completing adjustment.
(Refer to "Service Mode (service program)" on page 4.)
- Perform adjustments in the order given.
- Use YEDS-18 disc (part No. : 3-702-101-01) only indicated.
- Power supply voltage : DC 9V
HOLD switch : OFF
VOLUME knob : MIN

PREPARATION

Put the set into service mode (See page 4.) and perform the following checks.

• Sled Motor Check

- Press the OPEN button and open the top panel.
- Press the ►►, ◄◄ keys and make sure that the optical pick-up block moves smoothly, without catching, from the inmost → outmost → inmost circumference.
►► : UPF moves outward
◄◄ : UPF moves inward

• Focus Search Check

- Press the OPEN button and open the top panel.
- Press the ►► key. (Focus search is performed continuously.)
- Observe the UPF objective lens and check that it moves smoothly up and down with no catching or noises.
- Press the ■ key.
Check that focus search operation stops. If it does not, press the ■ key again.

Battery Remains Indication Adjustment

Adjustment procedure :

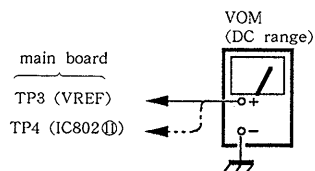

- Apply DC 3.5V both side of battery terminal.
- Insert the disc (YEDS-18) and press the ►► key.
- Adjust RV801 so that the voltage of TP4 (IC802) is the same as TP3 (V REF).

+ 3.9V Adjustment

Adjustment Procedure :

- Put the set into STOP state service mode (see page 4).
- Connect the VOM to main board test point TP(+3.9V).
- Adjust RV401 for 3.95V-4V reading on the VOM.
- After adjustment, release service mode (see page 4).

+ 3.4V Adjustment

Adjustment Procedure :

- Put the set into STOP state service mode (see page 4).
- Connect the VOM to main board test point TP (+3.4V).
- Adjust RV402 for 3.45V to 3.5V on the VOM reading.
- After adjustment, release service mode (see page 4).

+ 3.6V Adjustment

Adjustment Procedure :

- Apply DC 3V both side of battery terminal.
- Connect the VOM to main board test point TP7 (collector of Q437).
- Insert the disc (YEDS-18) and close the top panel.
- Press the ►► key.
- Adjust RV450 for 3.65V to 3.7V on the VOM reading.

PLL Free Run Frequency Check and Adjustment

Check/Adjustment Procedure :

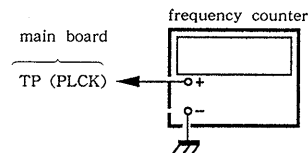

- Disconnect EFM solder jumper terminal on the main board.
- Connect a frequency counter to main board test point TP8 (IC601).
- Put the set into service mode (See page 4).
- Check that the frequency counter reading is 4.35 ± 0.01 MHz. If not, adjust RV504 so that it is 4.35 ± 0.01 MHz.
- After adjustment, release service mode (see page 4).
- Short the jumper terminal disconnected in step 1.

Tracking Balance Adjustment

Conditions :

The set should be placed either horizontally.

Adjustment Procedure :

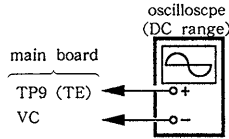

1. Connect the oscilloscope to main board TP9 (IC501①).
2. Put the set into service mode (See page 4.)
3. Press the ►► and ◄◄ keys to move the UPF to the center.
4. Insert the disc (YEDS-18) and close the top panel.
5. Press the ►► key.

It will go from focus search to focus on, and CLV pull-in mode state. Tracking and sled are OFF.

6. Adjust RV502 so that the oscilloscope waveform is symmetrical on the top and bottom in relation to 0V.

Note : Take sweep time as long as possible to obtain best waveform.

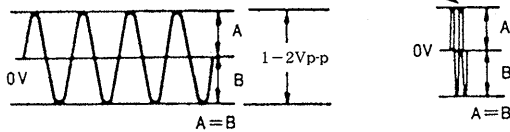

7. Unplug the external power supply to stop spindle motor from rotating.
8. After adjustment, release service mode (see page 4).

Focus Bias Adjustment

Conditions :

The set should be placed either horizontally.

Adjustment Procedure :

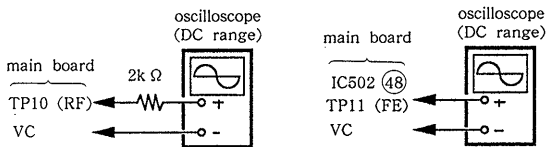

1. Put the set into STOP state in service mode (See page 4).
2. Connect the oscilloscope to main board test point TP10(IC501④).
3. Press the ►► and ◄◄ key to move the UPF to the center. (Move the UPF to the music area on the disc to enable easy visibility of the eye pattern).
4. Insert the disc (YEDS-18) and close the top panel.
5. Press the ►► key.

6. Press the KEY-MODE button.
7. Adjust RV503 so that the oscilloscope waveform eye pattern is good. A good eye pattern means that the diamond shape (◊) in the center of the waveform can be clearly distinguished.

• RF Signal Reference Waveform (eye pattern)

VOLT/DIV : 200mV

TIME/DIV : 500nS

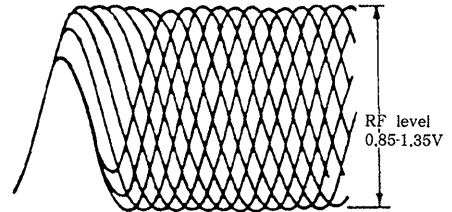

When observing the eye pattern, set the oscilloscope for AC range and raise vertical sensitivity.

8. Read the voltage on TP11 (IC502④).

voltage of TP (FE)	adjustment
+20mV to 50mV	Adjust RV503 again for +50mV reading on oscilloscope.
+20mV to -20mV	Adjust RV503 again for -20mV reading on oscilloscope.

9. Unplug the external power supply to stop spindle motor from rotating.
- Adjust RV503 again referring to the table followed.
10. After adjustment, release service mode (see page 4).

Adjustment Parts Location Diagram

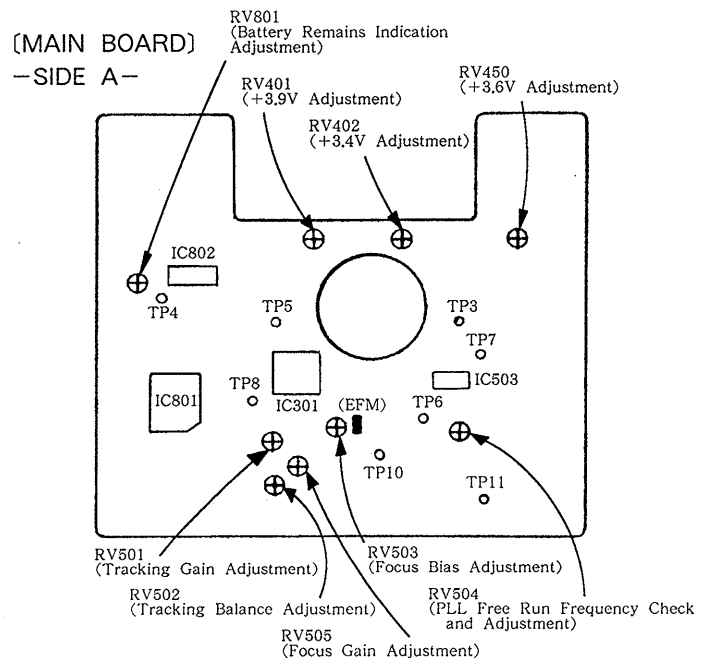

Reference

Focus/Tracking Gain Adjustment

On this set, it is very difficult to simplify this adjustment.

A frequency response analyzer or CD jig is necessary in order to perform this adjustment exactly.

However, this gain has a margin, so even if it is slightly off, there is no problem. Therefore, do not perform this adjustment.

Focus/tracking gain determines the pick-up followup (vertical and horizontal) relative to mechanical noise and mechanical shock when the 2-axis device operate.

- When gain is high, the noise when the 2-axis device operates increases.
- When gain is low, it is more susceptible to mechanical shock and skipping occurs more easily.

However, as these reciprocate, the adjustment is at the point where both are satisfied.

This adjustment is to be performed with using when replacing the following parts :

- UPF (optical pick-up block)
- RV501 (tracking gain volume)
- RV505 (focus gain volume)

CD jig connection :

Remove the solder jumpers at the TE and FE locations and connect the CD jig.

The adjustment procedure is described in the separate CD jig Instruction Manual.

Adjustment Parts Location Diagram
[MAIN BOARD] --SIDE A--

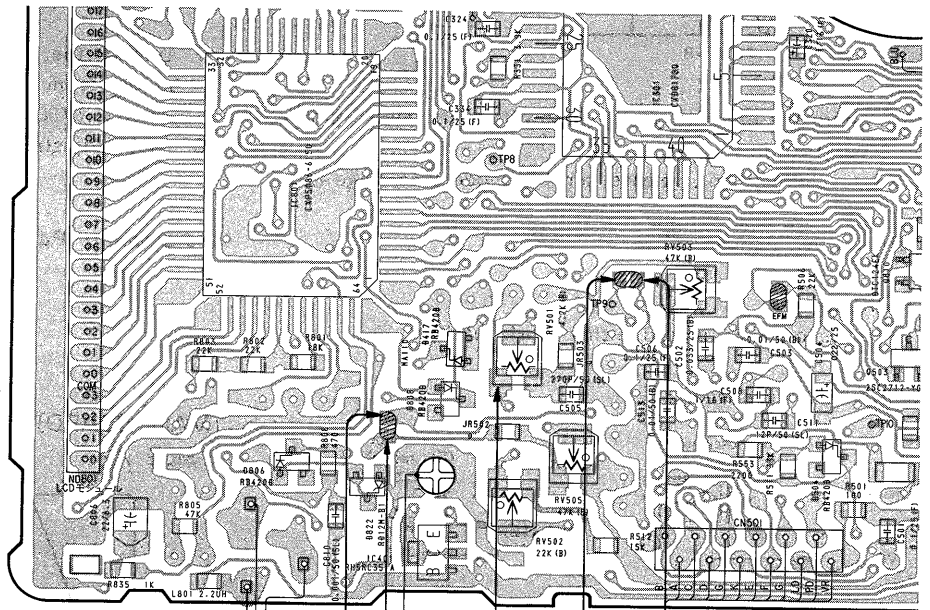

CD jig connection :

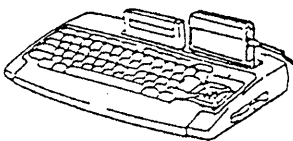

CD jig

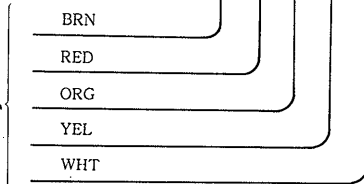
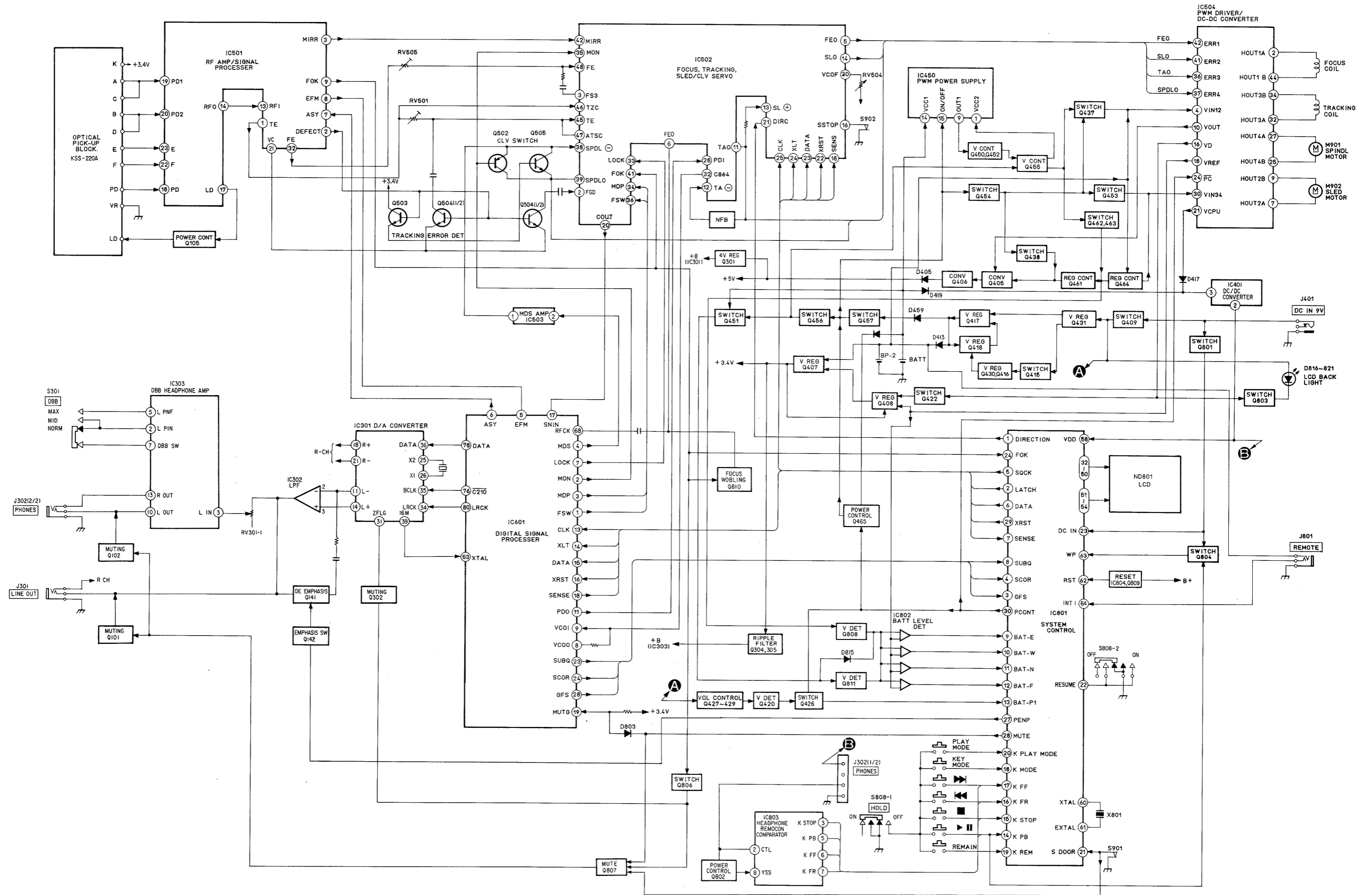
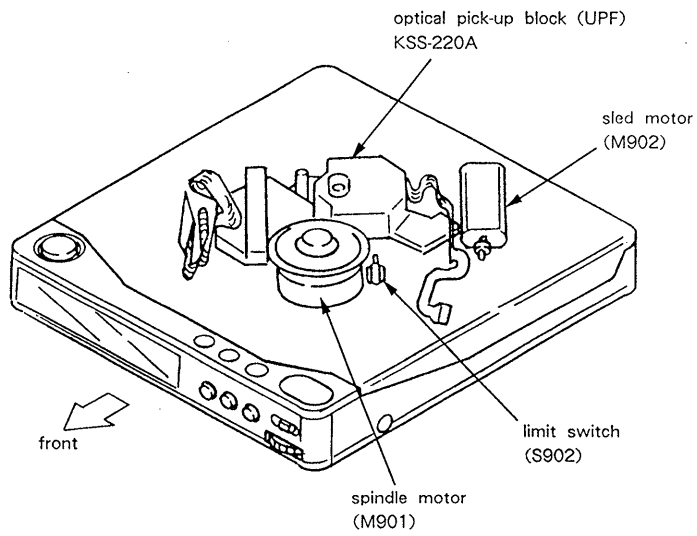
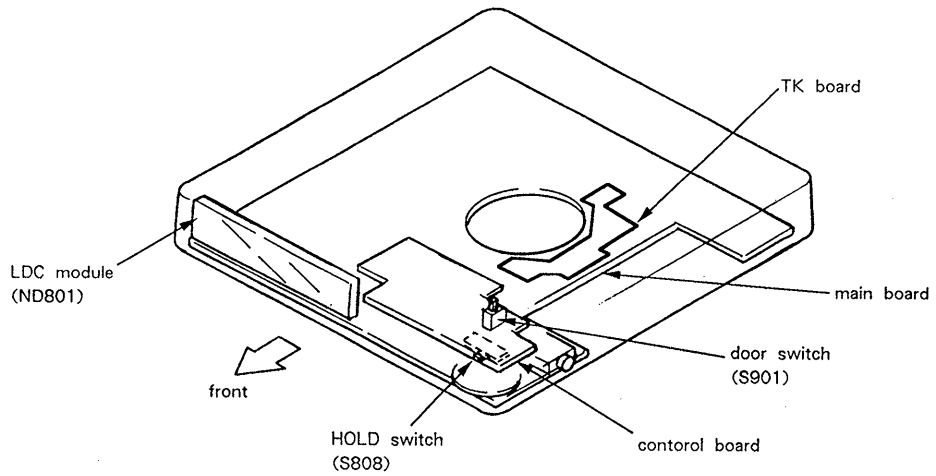

Fig.3

SECTION 4
DIAGRAMS



4-2. PC BOARD/SWITCH/MOTOR LAYOUTS



• LCD MODULE COMMON

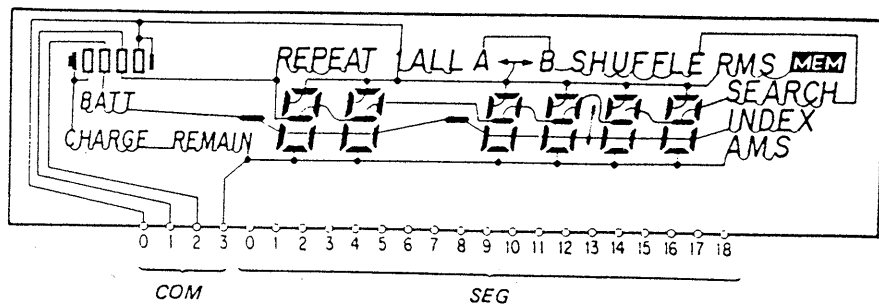

SEGMENT

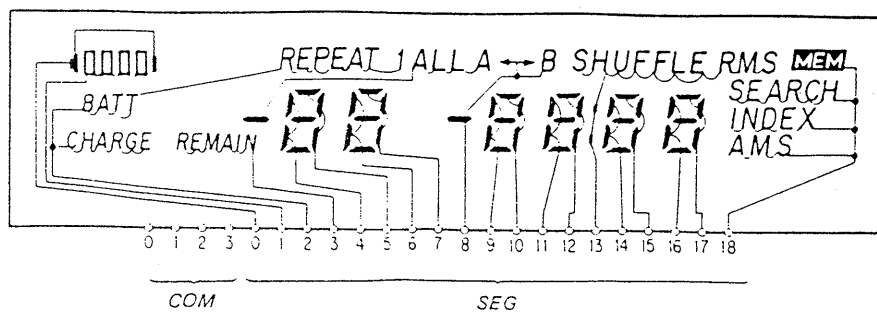

4-3. SEMICONDUCTOR LEAD LAYOUTS

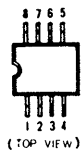
BA3818F-SY
NJM2100M

FMS1

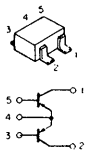

MA152WK

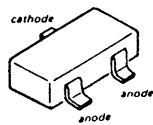

SLM-125YW-C1

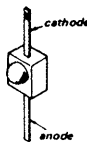

RH5RC351A

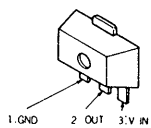

FMW1

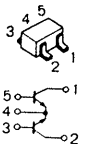
DAN204K
MA157

XN4312

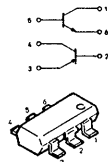

S-8052ANB

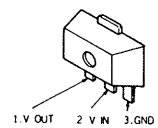
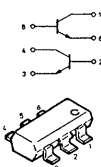
IMD2
XN4609

RB471E

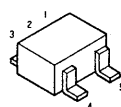
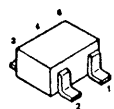
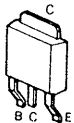
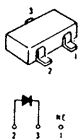
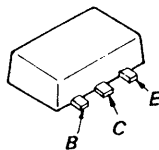
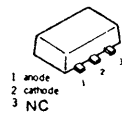
TC4S11F
TC7S04F2SB1182F5
2SD1758F5-RRB411D
RB420D
RD4.7M
RD5.6M
RD7.5M
RD8.2M
RD12M
SB05-05CP
SB01-05CPDTA124EK
DTA143TK
DTA144TK
DTC124EK
DTC124TK
DTC143TK
DTC144WK
2SA1037K
2SA1162
2SB1197K
2SC2712
2SD596
2SD1048X7
2SD1781K2SB798-DL
2SB1120
2SB1132
2SB1188
2SD1963RB110C
SB10-05PCP

2SK160-K6



• SEMICONDUCTOR LOCATION

Ref. No.	Location	Ref. No.	Location	Ref. No.	Location
IC301	G-12	Q438	D-16	D450	D-22
IC302	F-10	Q450	E-17	D451	E-16
IC303	C-29	Q451	D-16	D459	E-15
IC401	K-10	Q452	D-22	D464	H-29
IC450	E-22	Q453	E-16	D467	G-20
IC501	J-26	Q454	F-16	D468	F-23
IC502	I-23	Q455	E-21	D470	I-30
IC503	G-15	Q456	D-22	D485	F-17
IC504	I-21	Q461	D-17	D501	J-21
IC505	J-20	Q462	E-21	D502	J-18
IC801	H-26	Q483	F-20	D503	I-20
IC801	H-9	Q484	F-20	D504	J-13
IC802	E-9	Q485	B-26	D505	I-16
IC803	F-30	Q486	F-23	D506	H-16
IC804	I-29	Q501	J-25	D507	J-17
Q101	D-30	Q502	H-22	D508	J-18
Q102	B-9	Q503	I-13	D801	I-28
Q141	E-10	Q504	J-25	D802	H-28
Q142	E-28	Q505	I-16	D803	F-11
Q201	D-30	Q801	G-21	D804	G-29
Q202	B-9	Q802	F-8	D805	J-28
Q241	D-10	Q803	F-8	D806	J-9
Q242	D-30	Q804	I-28	D807	I-29
Q301	E-12	Q805	B-25	D808	J-10
Q302	G-28	Q806	H-28	D809	F-15
Q304	E-10	Q807	H-29	D810	G-21
Q305	D-10	Q808	E-29	D811	J-28
Q405	E-23	Q809	I-29	D812	J-29
Q406	D-24	Q810	I-13	D813	I-28
Q407	D-15	Q811	E-30	D814	I-29
Q408	D-14	Q813	B-25	D815	E-30
Q409	G-21	Q814	B-25	D816	H-30
Q410	F-23			D817	G-30
Q415	G-21	D401	C-17	D818	G-30
Q416	G-22	D405	D-13	D819	I-30
Q417	F-22	D409	F-23	D820	I-30
Q418	G-22	D410	F-15	D821	J-30
Q420	H-17	D411	F-18	D822	J-10
Q422	E-23	D412	H-16	D824	G-29
Q426	H-17	D413	F-17	D825	B-24
Q427	H-17	D415	F-21	D826	E-15
Q428	H-21	D416	K-28		
Q429	H-21	D417	I-10		
Q430	F-22	D418	B-25		
Q431	G-22	D419	I-10		
Q437	E-20	D420	B-24		

- : parts extracted from the component side.
- : parts extracted from the conductor side.
- : parts mounted on the conductor side.
- ⊗ : Through hole.
- ⊙ : Pattern on the side which is seen.
- ⊚ : Pattern of the rear side.

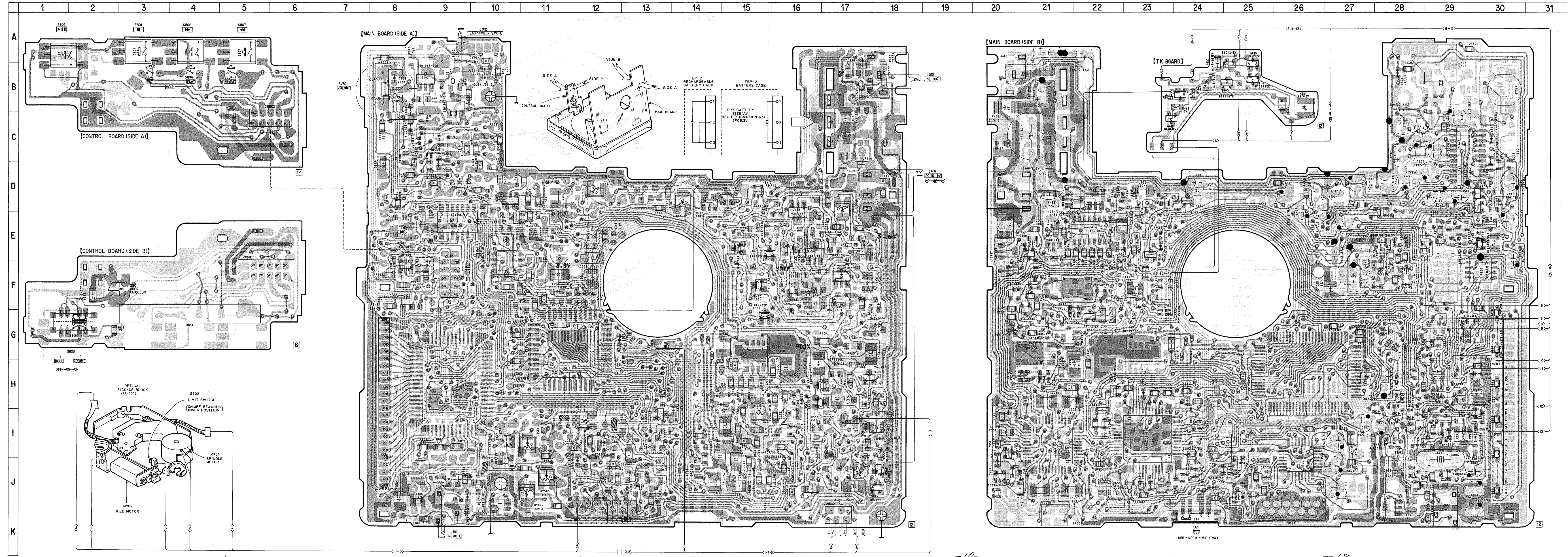

4.5. SCHEMATIC DIAGRAMS • See page 22 for IC Block Diagrams.

- Note:
- All capacitors are in μF unless otherwise noted. pF: μF 50WV or less are not indicated except for electrolytics and tantalums.
 - All resistors are in Ω and $\frac{1}{2}W$ or less unless otherwise specified.
 - % : indicates tolerance.
 - Δ : internal component.

Note:
The components identified by mark Δ or dotted line with mark Δ are critical for safety. Replace only with part number specified.

Note:
Les composants identifiés par une marque Δ ou pointillés pour la sécurité. Ne les remplacer que par une pièce portant le numéro spécifié.

- B+ Line
- adjustment for repair.
- Voltages and waveforms current are measured with top panel closed
- Power voltage is dc 9V and fed with regulated dc power supply from external power voltage jack.
- Voltage and waveforms are dc with respect to ground in service mode.
- no mark : play
- () : play (Battery operation)
- See page 4 for setup of service mode.
- Voltages are taken with a VOM (input impedance 10M Ω).
- Voltage variations may be noted due to normal production tolerances.
- Waveforms are taken with an oscilloscope.
- Signal path.
- CD

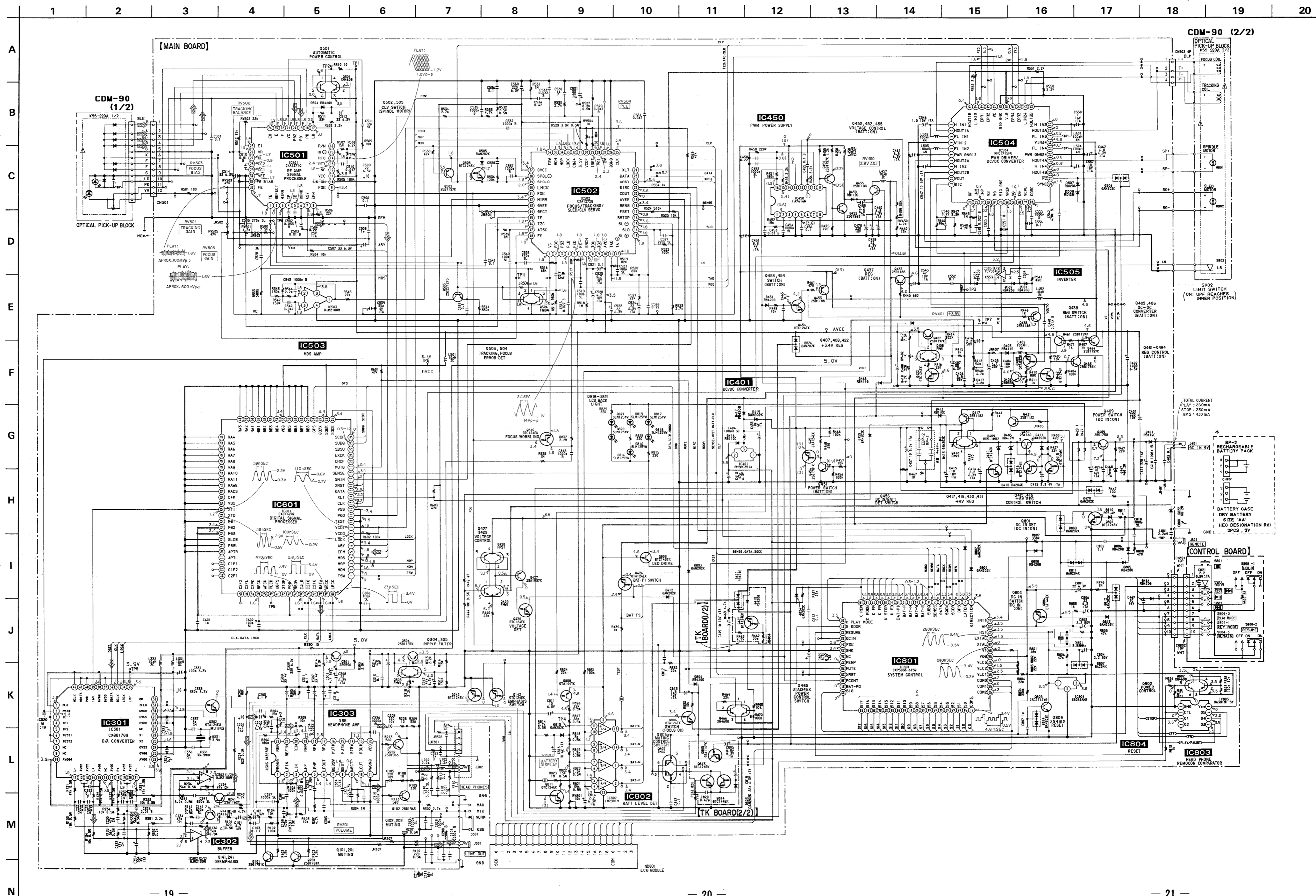

4-6. IC BLOCK DIAGRAMS

IC301 CXD8178Q

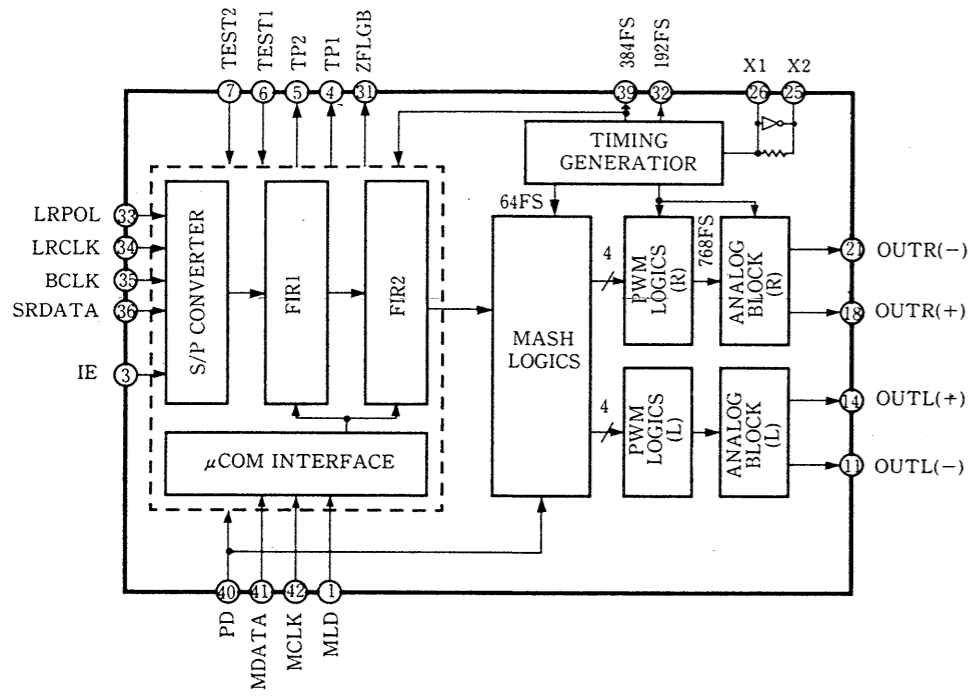

IC450 FA7616N

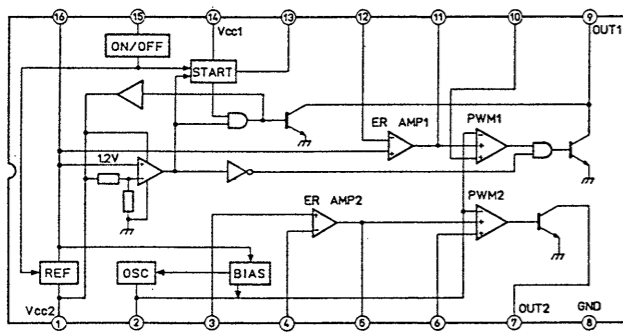

IC303 BA3570F

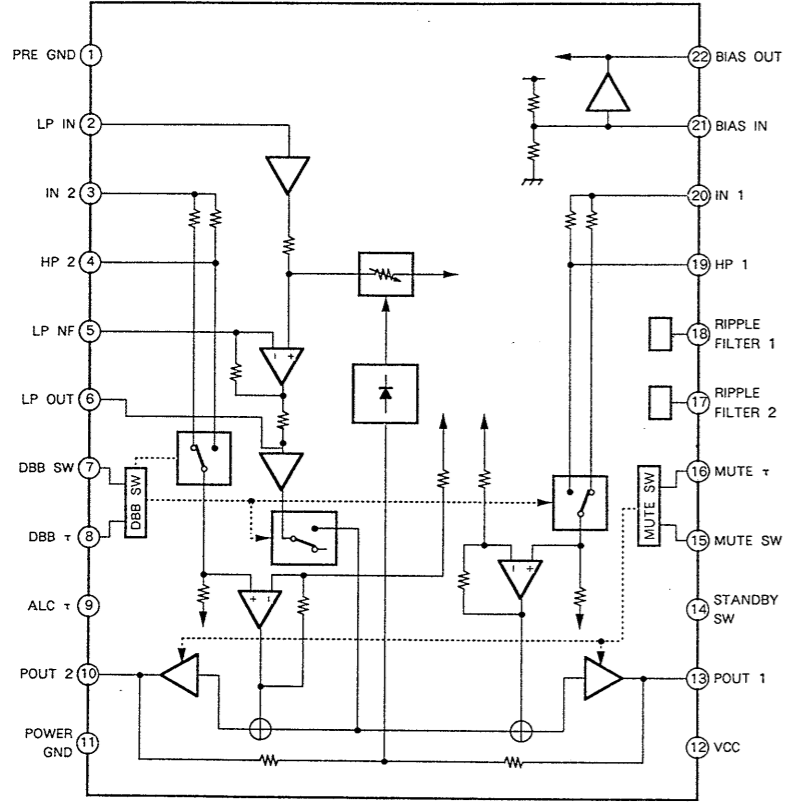

IC501 CXA1271Q

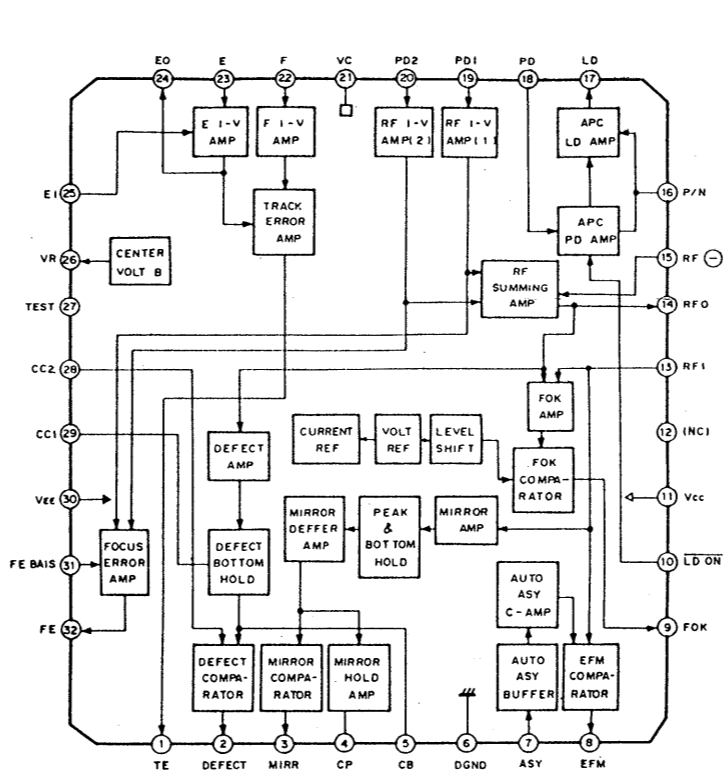

IC803 BA3818F-SY

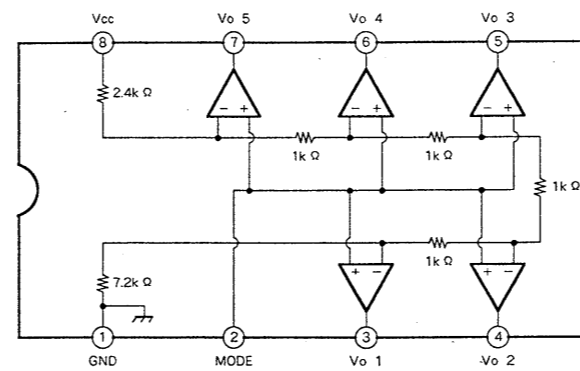

IC502 CXA1272Q

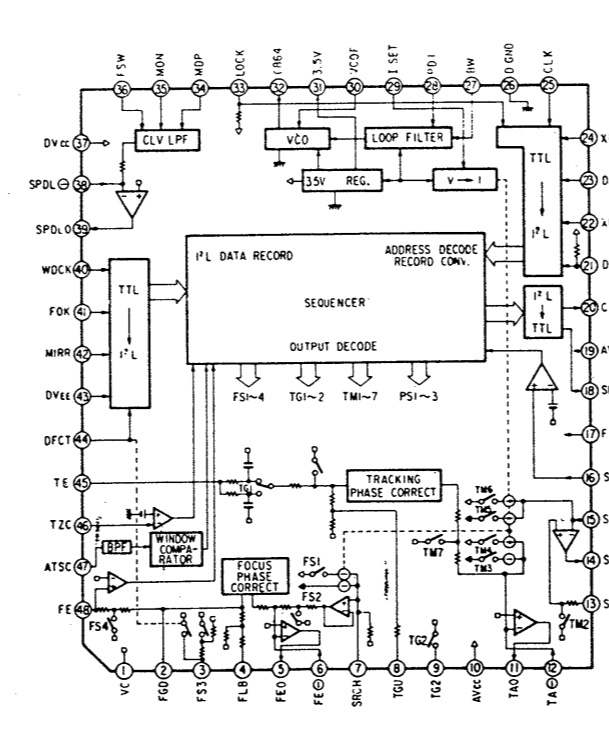

IC601 CXD1167Q

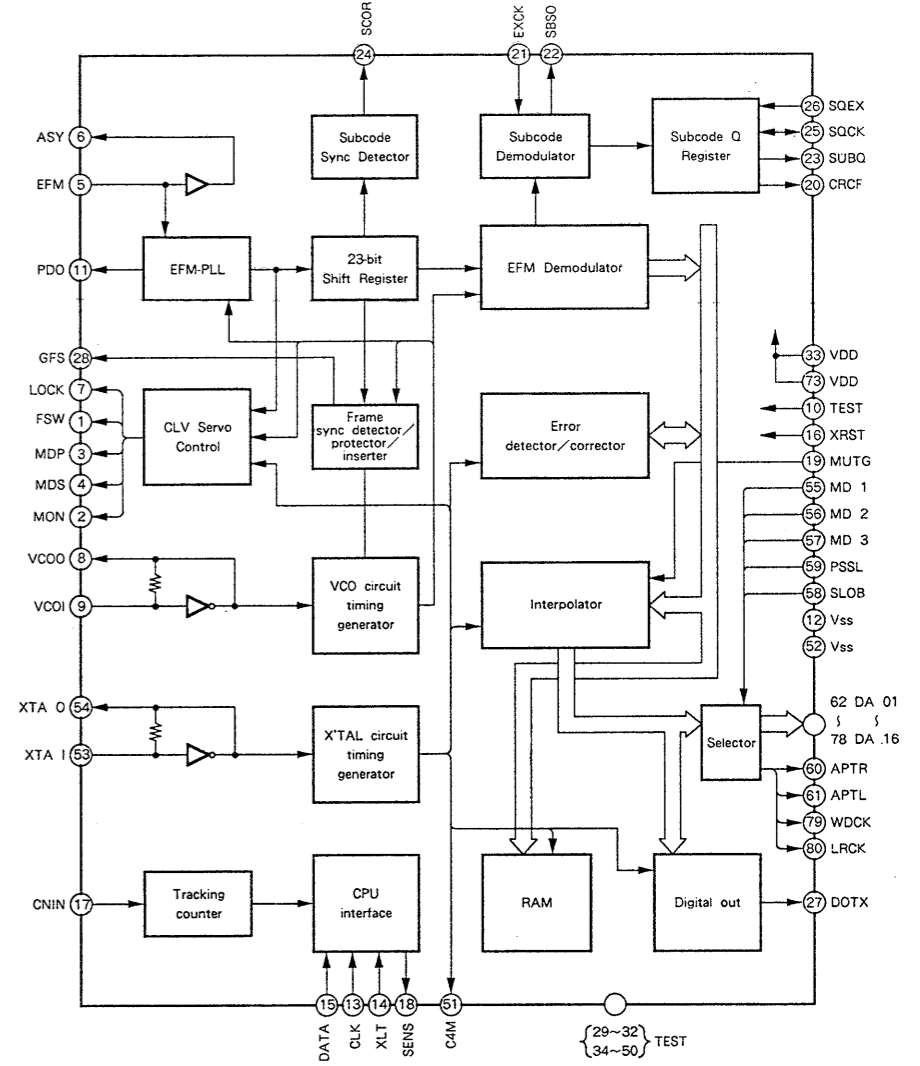

IC504 MPC1715

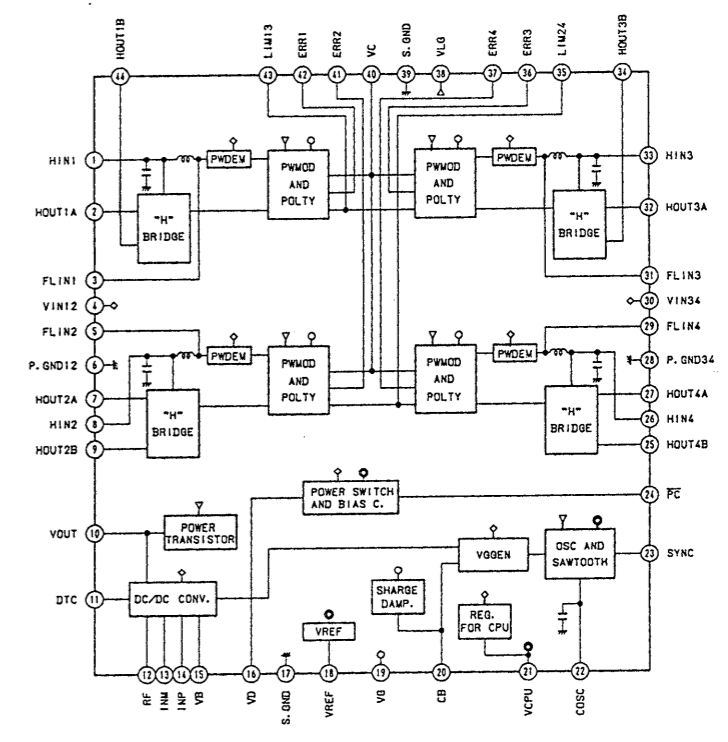



SECTION 5 EXPLODED VIEWS

NOTE:

- The mechanical parts with no reference number in the exploded views are not supplied.
- The construction parts of an assembled part are indicated with a collation number in the remark column.
- Items marked "★" are not stocked since they are seldom required for routine service. Some delay should be anticipated when ordering these items.

- Due to standardization, parts with part number suffix -XX and -X may be different from the parts specified in the components used on the set.
- Color Indication of Appearance Parts
Example:
(RED) ... KNOB, BALANCE (WHITE)
↑ ↑
Cabinet's Color Parts' Color

The components identified by mark  or dotted line with mark  are critical for safety. Replace only with part number specified.

Les composants identifiés par une marque  sont critiques pour la sécurité. Ne les remplacer que par une pièce portant le numéro spécifié.

(1) UPPER/BOTTOM SECTION

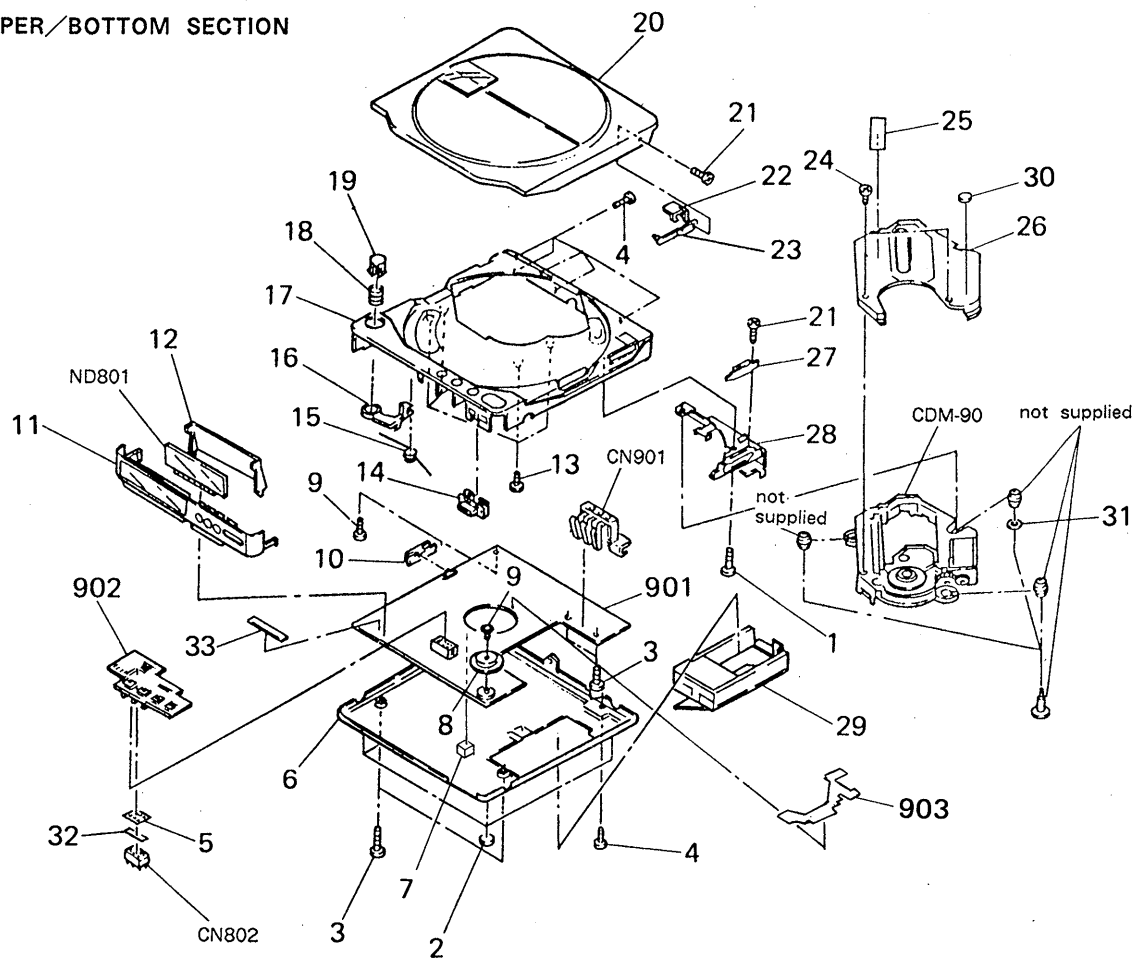



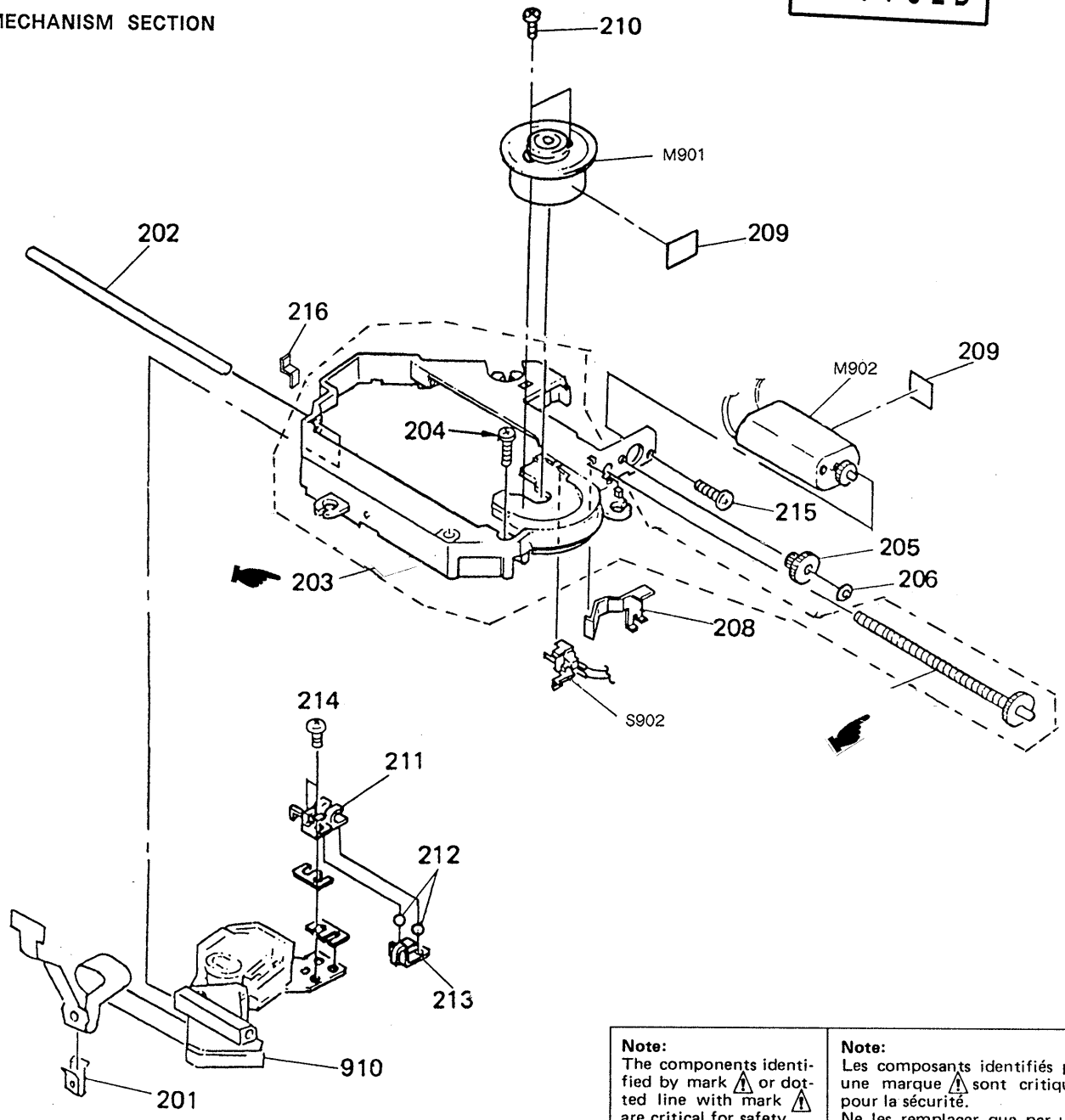

No.	Part No.	Description	Remarks	No.	Part No.	Description	Remarks
1	3-318-203-62	SCREW (B1.7X4), TAPPING		20	X-4930-134-1	PANEL, UPPER	
2	4-912-641-21	FOOT, RUBBER		21	3-703-816-02	SCREW (M1.4X2.0), SPECIAL HEAD	
3	4-908-792-71	SCREW (B2X6), TAPPING, P1		22	X-4930-102-1	BRACKET ASSY, SWITCHING PLATE	
4	3-703-816-52	SCREW (M1.4X3.5), SPECIAL HEAD		23	X-4921-216-1	PLATE (B) ASSY, SWITCHING	
5	★4-930-111-01	SPACER (CONNECTOR)		24	3-895-823-11	SCREW (B1.4X3), TAPPING	
6	X-4930-125-1	PLATE ASSY, BOTTOM		25	4-908-711-01	LABEL, CAUTION, LENS	
7	9-911-841-XX	CUSHION, CASSETTE LID		26	4-926-141-01	COVER, MD	
8	4-930-125-01	KNOB (VOLUME)		27	★4-917-753-01	SPRING	
9	3-335-797-21	SCREW (M1.4X3), TOOTHED LOCK		28	★4-930-129-01	PLATE (CLICK), FIXED	
10	4-930-114-01	KNOB (DBB)		29	X-4930-116-1	BOX ASSY (B), BATTERY	
11	X-4930-127-1	PANEL ASSY, FRONT		30	★4-924-188-01	CUSHION	
12	4-930-115-01	REFLECTOR		31	4-930-156-01	WASHER	
14	4-931-815-01	KNOB (HOLD)		32	7-632-453-52	SHEET (CONNECTOR), ADHESIVE	
15	4-930-109-01	SPRING, TORSION		33	4-930-160-01	SPACER (LCD)	
16	4-930-132-01	CLAW, LOCK, LID		901	A-3015-885-A	PC BOARD ASSY, MAIN	
17	X-4930-133-1	CABINET ASSY		902	★1-634-790-11	PC BOARD, CONTROL	
18	4-917-727-01	SPRING, COMPRESSION		903	★1-635-348-11	PC BOARD, TK	
19	4-930-121-01	BUTTON (OPEN)		CN901	4-930-131-01	TERMINAL, BATTERY	
				ND801	1-808-677-11	MODULE, LCD	

REVISED

(2) MECHANISM SECTION



<p>Note: The components identified by mark  or dotted line with mark  are critical for safety. Replace only with part number specified.</p>	<p>Note: Les composants identifiés par une marque  sont critiques pour la sécurité. Ne les remplacer que par une pièce portant le numéro spécifié.</p>
--	--

No.	Part No.	Description	Remarks	No.	Part No.	Description	Remarks
201	4-917-622-01	RETAINER, FLEXIBLE		212	7-671-111-11	STEEL, BOUL 1.5MM	
202	4-917-611-01	SHAFT (A)		213	4-921-296-01	SPRING	
203	X-4930-108-2	CHASSIS ASSY, MD		214	7-627-552-38	SCREW, PRECISION +P 1.7X3	
204	4-921-299-01	SCREW (1.7X8), SPECIAL		215	7-627-553-38	SCREW, PRECISION +P 2X3	
205	4-921-292-01	GEAR (B)		216	3-831-441-XX	CUSHION	
206	3-315-384-11	WASHER, STOPPER		910	 8-848-142-11	DEVICE, OPTICAL KSS-220A (RP)	
208	4-921-290-01	SPRING		M901	A-3133-372-A	MOTOR ASSY, CLV (SPINDLE MOTOR)	
209	*3-880-474-01	CUSHION, 15X5X0.3		M902	A-3133-334-A	MOTOR SUB ASSY, FEED (SLED MOTOR)	
210	7-627-552-08	SCREW, PRECISION +P 1.7X2.5		S902	1-571-099-11	SWITCH (LIMIT SW)	
211	4-921-294-01	RACK (A)					

SECTION 6

ELECTRICAL PARTS LIST

NOTE:

- Due to standardization, replacements in the parts list may be different from the parts specified in the diagrams or the components used on the set.
- Items marked "★" are not stocked since they are seldom required for routine service. Some delay should be anticipated when ordering these items.
- If there are two or more same circuits in a set such as a stereophonic machine, only typical circuit parts may be indicated and capacitors and resistors in other same circuits may be omitted.

CAPACITORS:MF: μ F, PF: μ F.**RESISTORS**

- All resistors are in ohms.
- F: nonflammable

COILS

- MMH: mH, UH: μ H

SEMICONDUCTORSIn each case, U: μ , for example:UA...: μ A..., UPA...: μ PA...,UPC...: μ PC, UPD...: μ PD...

The components identified by mark Δ or dotted line with mark Δ are critical for safety. Replace only with part number specified.

Les composants identifiés par une marque Δ sont critiques pour la sécurité. Ne les remplacer que par une pièce portant le numéro spécifié.

Ref.No.	Part No.	Description	Ref.No.	Part No.	Description
901	A-3015-885-A	PC BOARD ASSY, MAIN	C322	1-164-346-11	CERAMIC CHIP 1MF 16V
902	*1-634-790-11	PC BOARD, CONTROL	C323	1-126-154-11	ELECT 47MF 20% 6.3V
903	*1-635-348-11	PC BOARD, TK	C324	1-163-038-00	CERAMIC CHIP 0.1MF 25V
910	Δ 8-848-142-11	DEVICE, OPTICAL KSS-220A (RP)	C326	1-164-232-11	CERAMIC CHIP 0.01MF 10% 50V
C101	1-126-094-11	ELECT 4.7MF 20% 16V	C327	1-163-141-00	CERAMIC CHIP 0.001MF 5% 50V
C102	1-126-094-11	ELECT 4.7MF 20% 16V	C328	1-163-141-00	CERAMIC CHIP 0.001MF 5% 50V
C103	1-163-038-00	CERAMIC CHIP 0.1MF 25V	C329	1-163-141-00	CERAMIC CHIP 0.001MF 5% 50V
C104	1-164-161-11	CERAMIC CHIP 0.0022MF 10% 50V	C330	1-163-141-00	CERAMIC CHIP 0.001MF 5% 50V
C105	1-126-923-11	ELECT 220MF 20% 10V	C331	1-126-177-11	ELECT 100MF 20% 6.3V
C108	1-164-632-11	CERAMIC CHIP 2200PF 10% 50V	C332	1-163-038-00	CERAMIC CHIP 0.1MF 25V
C109	1-163-133-00	CERAMIC CHIP 470PF 5% 50V	C334	1-163-038-00	CERAMIC CHIP 0.1MF 25V
C110	1-163-141-00	CERAMIC CHIP 0.001MF 5% 50V	C336	1-163-091-00	CERAMIC CHIP 8PF 0.25PF 50V
C111	1-163-113-00	CERAMIC CHIP 68PF 5% 50V	C337	1-163-091-00	CERAMIC CHIP 8PF 0.25PF 50V
C131	1-163-121-00	CERAMIC CHIP 150PF 5% 50V	C338	1-124-442-00	ELECT 330MF 20% 6.3V
C132	1-163-121-00	CERAMIC CHIP 150PF 5% 50V	C339	1-124-442-00	ELECT 330MF 20% 6.3V
C133	1-163-109-00	CERAMIC CHIP 47PF 5% 50V	C351	1-135-162-21	TANTAL. CHIP 33MF 20% 4V
C134	1-163-109-00	CERAMIC CHIP 47PF 5% 50V	C401	1-126-923-11	ELECT 220MF 20% 10V
C141	1-163-139-00	CERAMIC CHIP 820PF 5% 50V	C402	1-126-916-11	ELECT 1000MF 20% 6.3V
C201	1-126-094-11	ELECT 4.7MF 20% 16V	C403	1-163-038-00	CERAMIC CHIP 0.1MF 25V
C202	1-126-094-11	ELECT 4.7MF 20% 35V	C404	1-124-584-00	ELECT 100MF 20% 10V
C203	1-163-038-00	CERAMIC CHIP 0.1MF 25V	C405	1-126-094-11	ELECT 4.7MF 20% 25V
C204	1-164-161-11	CERAMIC CHIP 0.0022MF 10% 50V	C406	1-126-162-11	ELECT 3.3MF 20% 35V
C205	1-126-923-11	ELECT 220MF 20% 10V	C407	1-124-229-00	ELECT 33MF 20% 6.3V
C208	1-164-632-11	CERAMIC CHIP 2200PF 10% 50V	C408	1-124-434-00	ELECT 220MF 20% 4V
C209	1-163-133-00	CERAMIC CHIP 470PF 10% 50V	C409	1-135-159-21	TANTAL. CHIP 10MF 20% 16V
C210	1-163-141-00	CERAMIC CHIP 0.001MF 5% 50V	C410	1-163-141-00	CERAMIC CHIP 0.001MF 5% 50V
C211	1-163-113-00	CERAMIC CHIP 68PF 5% 50V	C411	1-126-934-11	ELECT 220MF 20% 16V
C231	1-163-121-00	CERAMIC CHIP 150PF 5% 50V	C412	1-135-180-21	TANTAL. CHIP 3.3MF 20% 4V
C232	1-163-121-00	CERAMIC CHIP 150PF 5% 50V	C413	1-126-154-11	ELECT 47MF 20% 6.3V
C233	1-163-109-00	CERAMIC CHIP 47PF 5% 50V	C414	1-135-149-21	TANTAL. CHIP 2.2MF 20% 6.3V
C234	1-163-109-00	CERAMIC CHIP 47PF 5% 50V	C415	1-135-174-11	TANTAL. CHIP 10MF 20% 10V
C241	1-163-139-00	CERAMIC CHIP 820PF 5% 50V	C416	1-124-257-00	ELECT 2.2MF 20% 50V
C301	1-163-038-00	CERAMIC CHIP 0.1MF 25V	C448	1-164-232-11	CERAMIC CHIP 0.01MF 10% 50V
C302	1-126-162-11	ELECT 3.3MF 20% 25V	C449	1-135-174-11	TANTAL. CHIP 10MF 20% 10V
C303	1-163-038-00	CERAMIC CHIP 0.1MF 25V	C450	1-164-222-11	CERAMIC CHIP 0.22MF 25V
C304	1-164-222-11	CERAMIC CHIP 0.22MF 25V	C451	1-135-180-21	TANTAL. CHIP 3.3MF 20% 4V
C305	1-126-153-11	ELECT 22MF 20% 6.3V	C452	1-163-141-00	CERAMIC CHIP 0.001MF 5% 50V
C306	1-126-094-11	ELECT 4.7MF 20% 16V	C453	1-164-232-11	CERAMIC CHIP 0.01MF 10% 50V
C307	1-124-431-00	ELECT 33MF 20% 4V	C454	1-163-141-00	CERAMIC CHIP 0.001MF 5% 50V
C308	1-135-144-11	TANTAL. CHIP 22MF 20% 6.3V	C455	1-164-004-11	CERAMIC CHIP 0.1MF 10% 25V
C309	1-124-431-00	ELECT 33MF 20% 4V	C456	1-163-038-00	CERAMIC CHIP 0.1MF 25V
C310	1-163-038-00	CERAMIC CHIP 0.1MF 25V	C457	1-135-157-21	TANTAL. CHIP 10MF 20% 6.3V
C311	1-163-038-00	CERAMIC CHIP 0.1MF 25V	C458	1-135-157-21	TANTAL. CHIP 10MF 20% 4V
C313	1-163-038-00	CERAMIC CHIP 0.1MF 25V	C459	1-135-161-21	TANTAL. CHIP 22MF 20% 6.3V
C314	1-126-925-11	ELECT 470MF 20% 10V	C460	1-135-156-21	TANTAL. CHIP 6.8MF 20% 6.3V
C315	1-163-141-00	CERAMIC CHIP 0.001MF 5% 50V	C461	1-135-156-21	TANTAL. CHIP 6.8MF 20% 6.3V
C320	1-135-130-11	TANTAL. CHIP 4.7MF 20% 6.3V			
C321	1-164-346-11	CERAMIC CHIP 1MF 16V			

Ref.No.	Part No.	Description				Ref.No.	Part No.	Description			
C462	1-135-156-21	TANTAL. CHIP 6.8MF	20%	6.3V		C556	1-163-038-00	CERAMIC CHIP 0.1MF		25V	
C465	1-163-038-00	CERAMIC CHIP 0.1MF		25V		C557	1-135-174-11	TANTAL. CHIP 10MF	20%	10V	
C467	1-124-779-00	ELECT CHIP 10MF	20%	16V		C558	1-135-091-00	TANTAL. CHIP 1MF	20%	16V	
C468	1-135-174-11	TANTAL. CHIP 10MF	20%	10V		C559	1-163-133-00	CERAMIC CHIP 470PF	5%	50V	
C470	1-126-923-11	ELECT 220MF	20%	10V		C560	1-124-635-00	ELECT 220MF	20%	6.3V	
C499	1-135-149-21	TANTAL. CHIP 2.2MF	20%	6.3V		C561	1-163-035-00	CERAMIC CHIP 0.047MF		50V	
C501	1-163-038-00	CERAMIC CHIP 0.1MF		25V		C562	1-163-133-00	CERAMIC CHIP 470PF	5%	50V	
C502	1-163-989-11	CERAMIC CHIP 0.033MF	10%	25V		C601	1-162-638-11	CERAMIC CHIP 1MF		16V	
C503	1-164-232-11	CERAMIC CHIP 0.01MF	10%	50V		C602	1-163-117-00	CERAMIC CHIP 100PF	5%	50V	
C504	1-135-145-11	TANTAL. CHIP 0.47MF	20%	25V		C606	1-163-117-00	CERAMIC CHIP 100PF	5%	50V	
C505	1-163-127-00	CERAMIC CHIP 270PF	5%	50V		C801	1-124-638-11	ELECT 22MF	20%	6.3V	
C506	1-163-038-00	CERAMIC CHIP 0.1MF		25V		C802	1-163-038-00	CERAMIC CHIP 0.1MF		25V	
C507	1-124-229-00	ELECT 33MF	20%	6.3V		C803	1-124-257-00	ELECT 2.2MF	20%	50V	
C508	1-164-346-11	CERAMIC CHIP 1MF		16V		C804	1-124-257-00	ELECT 2.2MF	20%	50V	
C509	1-126-153-11	ELECT 22MF	20%	6.3V		C805	1-164-337-11	CERAMIC CHIP 2.2MF		16V	
C510	1-163-809-11	CERAMIC CHIP 0.047MF	10%	25V		C806	1-135-144-11	TANTAL. CHIP 22MF	20%	6.3V	
C511	1-163-095-00	CERAMIC CHIP 12PF	5%	50V		C807	1-164-346-11	CERAMIC CHIP 1MF		16V	
C512	1-124-229-00	ELECT 33MF	20%	6.3V		C808	1-164-346-11	CERAMIC CHIP 1MF		16V	
C513	1-164-232-11	CERAMIC CHIP 0.01MF	10%	50V		C809	1-164-346-11	CERAMIC CHIP 1MF		16V	
C514	1-124-229-00	ELECT 33MF	20%	6.3V		C810	1-163-141-00	CERAMIC CHIP 0.001MF	5%	50V	
C515	1-163-038-00	CERAMIC CHIP 0.1MF		25V		C811	1-126-157-11	ELECT 10MF	20%	6.3V	
C517	1-163-038-00	CERAMIC CHIP 0.1MF		25V		C812	1-163-038-00	CERAMIC CHIP 0.1MF		25V	
C518	1-163-037-11	CERAMIC CHIP 0.022MF	10%	25V		C813	1-163-038-00	CERAMIC CHIP 0.1MF		25V	
C519	1-163-117-00	CERAMIC CHIP 100PF	5%	50V		C814	1-135-149-21	TANTAL. CHIP 2.2MF	20%	6.3V	
C520	1-135-155-21	TANTAL. CHIP 4.7MF	20%	10V		C815	1-135-148-21	TANTAL. CHIP 1.5MF	20%	10V	
C521	1-163-038-00	CERAMIC CHIP 0.1MF		25V		C816	1-135-157-21	TANTAL. CHIP 10MF	20%	4V	
C522	1-135-144-11	TANTAL. CHIP 22MF	20%	6.3V		C817	1-164-346-11	CERAMIC CHIP 1MF		16V	
C523	1-163-117-00	CERAMIC CHIP 100PF	5%	50V		C818	1-163-009-11	CERAMIC CHIP 0.001MF	10%	50V	
C524	1-135-144-11	TANTAL. CHIP 22MF	20%	6.3V		C819	1-135-207-11	TANTAL. CHIP 68MF	20%	6.3V	
C525	1-135-155-21	TANTAL. CHIP 4.7MF	20%	10V		C820	1-162-637-11	CERAMIC CHIP 0.47MF		16V	
C526	1-164-222-11	CERAMIC CHIP 0.22MF		25V		C821	1-124-257-00	ELECT 2.2MF	20%	50V	
C527	1-163-125-00	CERAMIC CHIP 220PF	5%	50V		CN501	1-566-976-11	SOCKET, CONNECTOR 12P			
C528	1-162-638-11	CERAMIC CHIP 1MF		16V		CN502	1-565-309-11	CONNECTOR, FLEXIBLE 4P			
C529	1-163-809-11	CERAMIC CHIP 0.047MF	10%	25V		CN801	*1-568-434-11	SOCKET, CONNECTOR 10P			
C530	1-164-346-11	CERAMIC CHIP 1MF		16V		CN802	1-564-680-11	PIN, CONNECTOR 10P			
C531	1-135-162-21	TANTAL. CHIP 33MF	20%	4V		CN901	4-930-131-01	TERMINAL, BATTERY			
C532	1-163-009-11	CERAMIC CHIP 0.001MF	10%	50V		D401	8-719-938-78	DIODE SB10-05PCP			
C533	1-163-989-11	CERAMIC CHIP 0.033MF	10%	25V		D405	8-719-938-75	DIODE SB05-05CP			
C534	1-164-005-11	CERAMIC CHIP 0.47MF		25V		D409	8-719-105-82	DIODE RD5.1M-B2			
C535	1-163-009-11	CERAMIC CHIP 0.001MF	10%	50V		D410	8-719-403-80	DIODE MA157			
C536	1-163-038-00	CERAMIC CHIP 0.1MF		25V		D411	8-719-400-18	DIODE MA152WK			
C537	1-163-009-11	CERAMIC CHIP 0.001MF	10%	50V		D412	8-719-400-18	DIODE MA152WK			
C538	1-162-638-11	CERAMIC CHIP 1MF		16V		D413	8-719-938-78	DIODE SB10-05PCP			
C539	1-135-162-21	TANTAL. CHIP 33MF	20%	4V		D415	8-719-938-72	DIODE SB01-05CP			
C540	1-163-117-00	CERAMIC CHIP 100PF	5%	50V		D416	8-719-938-78	DIODE SB10-05PCP			
C541	1-163-038-00	CERAMIC CHIP 0.1MF		25V		D417	8-719-938-72	DIODE SB01-05CP			
C542	1-163-809-11	CERAMIC CHIP 0.047MF	10%	25V		D418	8-719-938-72	DIODE SB01-05CP			
C543	1-163-009-11	CERAMIC CHIP 0.001MF	10%	50V		D419	8-719-400-18	DIODE MA152WK			
C545	1-135-166-21	TANTAL. CHIP 47MF	20%	10V		D420	8-719-975-46	DIODE RB471E			
C546	1-135-148-21	TANTAL. CHIP 1.5MF	10%	10V		D450	8-719-938-78	DIODE SB10-05PCP			
C547	1-135-174-11	TANTAL. CHIP 10MF	20%	10V		D451	8-719-938-72	DIODE SB01-05CP			
C548	1-164-222-11	CERAMIC CHIP 0.22MF		25V		D459	8-719-400-18	DIODE MA152WK			
C549	1-163-986-00	CERAMIC CHIP 0.027MF	10%	25V		D464	8-719-938-72	DIODE SB01-05CP			
C550	1-162-638-11	CERAMIC CHIP 1MF		16V		D467	8-719-106-35	DIODE RD8.2M-B2			
C551	1-163-038-00	CERAMIC CHIP 0.1MF		25V		D468	8-719-938-75	DIODE SB05-05CP			
C552	1-163-038-00	CERAMIC CHIP 0.1MF		25V		D470	8-719-400-18	DIODE MA152WK			
C553	1-162-638-11	CERAMIC CHIP 1MF		16V		D485	8-719-105-72	DIODE RD4.7M-B1			
C554	1-162-638-11	CERAMIC CHIP 1MF		16V							
C555	1-163-009-11	CERAMIC CHIP 0.001MF	10%	50V							

Ref.No.	Part No.	Description
D501	8-719-938-72	DIODE SB01-05CP
D502	8-719-938-72	DIODE SB01-05CP
D503	8-719-938-72	DIODE SB01-05CP
D504	8-719-938-72	DIODE SB01-05CP
D505	8-719-400-18	DIODE MA152WK
D506	8-719-400-18	DIODE MA152WK
D507	8-719-106-70	DIODE RD12M-B1
D508	8-719-106-70	DIODE RD12M-B1
D801	8-719-400-18	DIODE MA152WK
D802	8-719-400-18	DIODE MA152WK
D803	8-719-400-18	DIODE MA152WK
D804	8-719-400-18	DIODE MA152WK
D805	8-719-938-72	DIODE SB01-05CP
D806	8-719-938-72	DIODE SB01-05CP
D807	8-719-403-80	DIODE MA157
D808	8-719-938-72	DIODE SB01-05CP
D809	8-719-400-18	DIODE MA152WK
D810	8-719-105-90	DIODE RD5.6M-B1
D811	8-719-403-80	DIODE MA157
D812	8-719-400-18	DIODE MA152WK
D813	8-719-400-18	DIODE MA152WK
D814	8-719-400-18	DIODE MA152WK
D815	8-719-400-18	DIODE MA152WK
D816	8-719-970-11	DIODE SLM-125YW-C1
D817	8-719-970-11	DIODE SLM-125YW-C1
D818	8-719-970-11	DIODE SLM-125YW-C1
D819	8-719-970-11	DIODE SLM-125YW-C1
D820	8-719-970-11	DIODE SLM-125YW-C1
D821	8-719-970-11	DIODE SLM-125YW-C1
D822	8-719-106-70	DIODE RD12M-B1
D824	8-719-400-18	DIODE MA152WK
D825	8-719-911-19	DIODE 1SS119
D826	8-719-400-18	DIODE MA152WK
IC301	8-759-420-86	IC CXD8178Q
IC302	8-759-710-55	IC NJM2100M
IC303	8-759-991-27	IC BA3570F
IC401	8-759-994-55	IC RH5RC351A
IC450	8-759-982-61	IC FA7616N
IC501	8-752-033-55	IC CXA1271Q
IC502	8-752-033-54	IC CXA1272Q-Z
IC503	8-759-710-55	IC NJM2100M
IC504	8-759-030-17	IC MPC1715FU
IC505	8-759-230-43	IC TC7S04F
IC601	8-752-334-28	IC CXD1167Q
IC801	8-752-815-36	IC CXP5086-615Q
IC802	8-759-981-61	IC LM2901M
IC803	8-759-998-50	IC BA3818F-SY
IC804	8-759-945-21	IC S-8052ANB-NE
J301	1-562-870-21	JACK (LINE OUT)
J302	1-568-758-11	JACK (PHONES/REMOTE)
J401	1-562-961-11	JACK (DC IN 9V)
J801	1-568-257-11	JACK (REMOTE)
JR107	1-216-295-00	METAL GLAZE 0 5% 1/10W
JR207	1-216-295-00	METAL GLAZE 0 5% 1/10W
JR301	1-216-295-00	METAL GLAZE 0 5% 1/10W
JR302	1-216-295-00	METAL GLAZE 0 5% 1/10W
JR401	1-216-295-00	METAL GLAZE 0 5% 1/10W
JR402	1-216-295-00	METAL GLAZE 0 5% 1/10W

Ref.No.	Part No.	Description
JR403	1-216-295-00	METAL GLAZE 0 5% 1/10W
JR404	1-216-296-00	METAL GLAZE 0 5% 1/8W
JR405	1-216-295-00	METAL GLAZE 0 5% 1/10W
JR406	1-216-295-00	METAL GLAZE 0 5% 1/10W
JR407	1-216-296-00	METAL GLAZE 0 1/8W
JR410	1-216-296-00	METAL GLAZE 0 5% 1/8W
JR501	1-216-295-00	METAL GLAZE 0 5% 1/10W
JR502	1-216-295-00	METAL GLAZE 0 5% 1/10W
JR503	1-216-295-00	METAL GLAZE 0 5% 1/10W
JR504	1-216-295-00	METAL GLAZE 0 5% 1/10W
L102	1-410-997-31	INDUCTOR CHIP 2.2UH
L202	1-410-997-31	INDUCTOR CHIP 2.2UH
L331	1-412-029-11	INDUCTOR CHIP 10UH
L332	1-412-029-11	INDUCTOR CHIP 10UH
L334	1-412-031-11	INDUCTOR CHIP 47UH
L402	1-412-039-51	INDUCTOR CHIP 100UH
L404	1-412-032-11	INDUCTOR CHIP 100UH
L450	1-459-961-11	COIL (WITH CORE)
L452	1-412-029-11	INDUCTOR CHIP 10UH
L457	1-412-029-11	INDUCTOR CHIP 10UH
L501	1-412-029-11	INDUCTOR CHIP 10UH
L502	1-412-039-51	INDUCTOR CHIP 100UH
L503	1-412-039-51	INDUCTOR CHIP 100UH
L504	1-412-039-51	INDUCTOR CHIP 100UH
L505	1-412-039-51	INDUCTOR CHIP 100UH
L801	1-410-997-31	INDUCTOR CHIP 2.2UH
M901	A-3133-372-A	MOTOR ASSY, CLV (SPINDLE MOTOR)
M902	A-3133-334-A	MOTOR SUB ASSY, FEED (SLED MOTOR)
ND801	1-808-677-11	MODULE, LCD
Q101	8-729-921-72	TRANSISTOR 2SD1781K-R
Q102	8-729-923-36	TRANSISTOR 2SD1963-Q.R
Q141	8-729-216-22	TRANSISTOR 2SA1162Y
Q142	8-729-901-00	TRANSISTOR DTC124EK
Q201	8-729-921-72	TRANSISTOR 2SD1781K-R
Q202	8-729-923-36	TRANSISTOR 2SD1963-Q.R
Q241	8-729-216-22	TRANSISTOR 2SA1162Y
Q242	8-729-901-00	TRANSISTOR DTC124EK
Q301	8-729-159-64	TRANSISTOR 2SD596
Q302	8-729-905-57	TRANSISTOR DTA124EU
Q304	8-729-904-87	TRANSISTOR 2SB1197K
Q305	8-729-903-10	TRANSISTOR FMW1
Q405	8-729-923-68	TRANSISTOR DTA113ZK
Q406	8-729-159-64	TRANSISTOR 2SD596
Q407	8-729-904-87	TRANSISTOR 2SB1197K-R
Q408	8-729-903-10	TRANSISTOR FMW1
Q409	8-729-922-27	TRANSISTOR 2SD1758-R
Q410	8-729-901-00	TRANSISTOR DTC124EK
Q415	8-729-901-03	TRANSISTOR DTC144WK
Q416	8-729-901-00	TRANSISTOR DTC124EK
Q417	8-729-921-84	TRANSISTOR 2SB1182F5-Q
Q418	8-729-903-10	TRANSISTOR FMW1
Q420	8-729-901-00	TRANSISTOR DTC124EK
Q422	8-729-901-00	TRANSISTOR DTC124EK
Q426	8-729-901-05	TRANSISTOR DTA124EK
Q427	8-729-920-71	TRANSISTOR 2SA1037K-QR
Q428	8-729-902-96	TRANSISTOR FMS1
Q429	8-729-903-10	TRANSISTOR FMW1
Q430	8-729-116-06	TRANSISTOR 2SK160-K6
Q431	8-729-101-07	TRANSISTOR 2SB798-DL

Note:

The components identified by mark Δ or dotted line with mark Δ are critical for safety. Replace only with part number specified.

Note:

Les composants identifiés par une marque Δ sont critiques pour la sécurité. Ne les remplacer que par une pièce portant le numéro spécifié.

Ref.No.	Part No.	Description
Q437	8-729-806-76	TRANSISTOR 2SB1120-G
Q438	8-729-806-76	TRANSISTOR 2SB1120-G
Q450	8-729-904-87	TRANSISTOR 2SB1197K-R
Q451	8-729-901-05	TRANSISTOR DTA124EK
Q452	8-729-923-36	TRANSISTOR 2SD1963-Q.R
Q453	8-729-806-76	TRANSISTOR 2SB1120-G
Q454	8-729-901-00	TRANSISTOR DTC124EK
Q455	8-729-806-76	TRANSISTOR 2SB1120-G
Q456	8-729-800-37	TRANSISTOR 2SD1048X7
Q461	8-729-904-87	TRANSISTOR 2SB1197K-R
Q462	8-729-901-00	TRANSISTOR DTC124EK
Q463	8-729-800-37	TRANSISTOR 2SD1048X7
Q464	8-729-904-87	TRANSISTOR 2SB1197K-R
Q465	8-729-901-05	TRANSISTOR DTA124EK
Q466	8-729-402-16	TRANSISTOR XN4608
Q501	8-729-402-90	TRANSISTOR XN4609
Q502	8-729-904-87	TRANSISTOR 2SB1197K-R
Q503	8-729-230-49	TRANSISTOR 2SC2712-YG
Q504	8-729-902-93	TRANSISTOR FMG4
Q505	8-729-901-00	TRANSISTOR DTC124EK
Q801	8-729-901-00	TRANSISTOR DTC124EK
Q802	8-729-402-16	TRANSISTOR XN4608
Q803	8-729-900-98	TRANSISTOR DTC143TK
Q804	8-729-901-05	TRANSISTOR DTA124EK
Q805	8-729-901-46	TRANSISTOR DTA114YK
Q806	8-729-901-05	TRANSISTOR DTA124EK
Q807	8-729-907-39	TRANSISTOR IMD2
Q808	8-729-903-29	TRANSISTOR DTA144TK
Q809	8-729-230-49	TRANSISTOR 2SC2712-YG
Q810	8-729-901-00	TRANSISTOR DTC124EK
Q811	8-729-901-00	TRANSISTOR DTC124EK
Q813	8-729-901-00	TRANSISTOR DTC124EK
Q814	8-729-901-01	TRANSISTOR DTC144EK
R101	1-216-649-11	METAL CHIP 820 0.50% 1/10W
R102	1-216-097-00	METAL GLAZE 100K 5% 1/10W
R103	1-216-053-00	METAL GLAZE 1.5K 5% 1/10W
R104	1-216-077-00	METAL GLAZE 15K 5% 1/10W
R105	1-216-073-00	METAL GLAZE 10K 5% 1/10W
R106	1-216-097-00	METAL GLAZE 100K 5% 1/10W
R107	1-216-635-11	METAL CHIP 220 0.50% 1/10W
R108	1-216-001-00	METAL GLAZE 10 5% 1/10W
R109	1-216-037-00	METAL GLAZE 330 5% 1/10W
R110	1-216-298-00	METAL GLAZE 2.2 5% 1/10W
R113	1-216-043-00	METAL GLAZE 560 5% 1/10W
R131	1-216-691-11	METAL CHIP 47K 0.50% 1/10W
R132	1-216-691-11	METAL CHIP 47K 0.50% 1/10W
R133	1-216-675-11	METAL CHIP 10K 0.50% 1/10W
R134	1-216-675-11	METAL CHIP 10K 0.50% 1/10W
R135	1-216-693-11	METAL CHIP 56K 0.50% 1/10W
R136	1-216-693-11	METAL CHIP 56K 0.50% 1/10W
R140	1-216-065-00	METAL GLAZE 4.7K 5% 1/10W
R141	1-216-673-11	METAL CHIP 8.2K 0.50% 1/10W
R201	1-216-649-11	METAL CHIP 820 0.50% 1/10W
R202	1-216-097-00	METAL GLAZE 100K 5% 1/10W
R203	1-216-053-00	METAL GLAZE 1.5K 5% 1/10W
R204	1-216-077-00	METAL GLAZE 15K 5% 1/10W
R205	1-216-073-00	METAL GLAZE 10K 5% 1/10W

Ref.No.	Part No.	Description
R206	1-216-097-00	METAL GLAZE 100K 5% 1/10W
R207	1-216-635-11	METAL CHIP 220 0.50% 1/10W
R208	1-216-001-00	METAL GLAZE 10 5% 1/10W
R209	1-216-037-00	METAL GLAZE 330 5% 1/10W
R210	1-216-298-00	METAL GLAZE 2.2 5% 1/10W
R213	1-216-043-00	METAL GLAZE 560 5% 1/10W
R231	1-216-691-11	METAL CHIP 47K 0.50% 1/10W
R232	1-216-691-11	METAL CHIP 47K 0.50% 1/10W
R233	1-216-675-11	METAL CHIP 10K 0.50% 1/10W
R234	1-216-675-11	METAL CHIP 10K 0.50% 1/10W
R235	1-216-693-11	METAL CHIP 56K 0.50% 1/10W
R236	1-216-693-11	METAL CHIP 56K 0.50% 1/10W
R240	1-216-065-00	METAL GLAZE 4.7K 5% 1/10W
R241	1-216-673-11	METAL CHIP 8.2K 0.50% 1/10W
R301	1-216-065-00	METAL GLAZE 4.7K 5% 1/10W
R302	1-216-059-00	METAL GLAZE 2.7K 5% 1/10W
R303	1-216-063-00	METAL GLAZE 3.9K 5% 1/10W
R304	1-216-121-00	METAL GLAZE 1M 5% 1/10W
R305	1-216-101-00	METAL GLAZE 150K 5% 1/10W
R314	1-216-063-00	METAL GLAZE 3.9K 5% 1/10W
R315	1-216-057-00	METAL GLAZE 2.2K 5% 1/10W
R316	1-216-077-00	METAL GLAZE 15K 5% 1/10W
R317	1-216-101-00	METAL GLAZE 150K 5% 1/10W
R318	1-216-057-00	METAL GLAZE 2.2K 5% 1/10W
R331	1-216-063-00	METAL GLAZE 3.9K 5% 1/10W
R351	1-216-057-00	METAL GLAZE 2.2K 5% 1/10W
R352	1-216-057-00	METAL GLAZE 2.2K 5% 1/10W
R404	1-216-097-00	METAL GLAZE 100K 5% 1/10W
R405	1-216-073-00	METAL GLAZE 10K 5% 1/10W
R407	1-216-049-00	METAL GLAZE 1K 5% 1/10W
R408	1-216-045-00	METAL GLAZE 680 5% 1/10W
R409	1-216-041-00	METAL GLAZE 470 5% 1/10W
R410	1-216-045-00	METAL GLAZE 680 5% 1/10W
R411	1-216-049-00	METAL GLAZE 1K 5% 1/10W
R412	1-216-091-00	METAL GLAZE 56K 5% 1/10W
R413	1-216-069-00	METAL GLAZE 6.8K 5% 1/10W
R414	1-216-081-00	METAL GLAZE 22K 5% 1/10W
R415	1-216-049-00	METAL GLAZE 1K 5% 1/10W
R416	1-216-033-00	METAL GLAZE 220 5% 1/10W
R417	1-216-070-00	METAL GLAZE 7.5K 5% 1/10W
R418	1-216-065-00	METAL GLAZE 4.7K 5% 1/10W
R421	1-216-033-00	METAL GLAZE 220 5% 1/10W
R427	1-217-806-11	METAL GLAZE 1 5% 1/8W
R428	1-217-806-11	METAL GLAZE 1 5% 1/8W
R437	1-216-081-00	METAL GLAZE 22K 5% 1/10W
R438	1-216-041-00	METAL GLAZE 470 5% 1/10W
R439	1-216-049-00	METAL GLAZE 1K 5% 1/10W
R440	1-216-081-00	METAL GLAZE 22K 5% 1/10W
R441	1-216-049-00	METAL GLAZE 1K 5% 1/10W
R442	1-216-017-00	METAL GLAZE 47 5% 1/10W
R443	1-216-041-00	METAL GLAZE 470 5% 1/10W
R444	1-216-675-11	METAL CHIP 10K 0.50% 1/10W
R445	1-216-045-00	METAL GLAZE 680 5% 1/10W
R446	1-216-049-00	METAL GLAZE 1K 5% 1/10W
R447	1-216-025-00	METAL GLAZE 100 5% 1/10W
R448	1-216-150-00	METAL GLAZE 10 5% 1/8W
R449	1-216-081-00	METAL GLAZE 22K 5% 1/10W

Note:

The components identified by mark **A** or dotted line with mark **A** are critical for safety. Replace only with part number specified.

Note:

Les composants identifiés par une marque **A** sont critiques pour la sécurité. Ne les remplacer que par une pièce portant le numéro spécifié.

Ref.No.	Part No.	Description						
R450	1-216-105-00	METAL GLAZE	220K	5%	1/10W			
R451	1-216-103-00	METAL GLAZE	180K	5%	1/10W			
R452	1-216-077-00	METAL GLAZE	15K	5%	1/10W			
R453	1-216-057-00	METAL GLAZE	2.2K	5%	1/10W			
R454	1-216-071-00	METAL GLAZE	8.2K	5%	1/10W			
R455	1-216-051-00	METAL GLAZE	1.2K	5%	1/10W			
R456	1-216-097-00	METAL GLAZE	100K	5%	1/10W			
R457	1-216-073-00	METAL GLAZE	10K	5%	1/10W			
R458	1-216-017-00	METAL GLAZE	47	5%	1/10W			
R459	1-216-085-00	METAL GLAZE	33K	5%	1/10W			
R460	1-216-077-00	METAL GLAZE	15K	5%	1/10W			
R461	1-216-041-00	METAL GLAZE	470	5%	1/10W			
R462	1-216-081-00	METAL GLAZE	22K	5%	1/10W			
R463	1-216-065-00	METAL GLAZE	4.7K	5%	1/10W			
R464	1-216-081-00	METAL GLAZE	22K	5%	1/10W			
R465	1-216-073-00	METAL GLAZE	10K	5%	1/10W			
R466	1-216-097-00	METAL GLAZE	100K	5%	1/10W			
R467	1-216-121-00	METAL GLAZE	1M	5%	1/10W			
R468	1-216-045-00	METAL GLAZE	680	5%	1/10W			
R469	1-216-214-00	METAL GLAZE	4.7K	5%	1/8W			
R470	1-216-097-00	METAL GLAZE	100K	5%	1/10W			
R471	1-216-049-00	METAL GLAZE	1K	5%	1/10W			
R475	1-216-033-00	METAL GLAZE	220	5%	1/10W			
R476	1-216-121-00	METAL GLAZE	1M	5%	1/10W			
R500	1-216-070-00	METAL GLAZE	7.5K	5%	1/10W			
R501	1-216-025-00	METAL GLAZE	100	5%	1/10W			
R504	1-216-073-00	METAL GLAZE	10K	5%	1/10W			
R505	1-216-103-00	METAL GLAZE	180K	5%	1/10W			
R506	1-216-081-00	METAL GLAZE	22K	5%	1/10W			
R507	1-216-077-00	METAL GLAZE	15K	5%	1/10W			
R508	1-216-068-00	METAL GLAZE	6.2K	5%	1/10W			
R509	1-216-073-00	METAL GLAZE	10K	5%	1/10W			
R510	1-216-150-00	METAL GLAZE	10	5%	1/8W			
R511	1-216-085-00	METAL GLAZE	33K	5%	1/10W			
R512	1-216-077-00	METAL GLAZE	15K	5%	1/10W			
R514	1-216-109-00	METAL GLAZE	330K	5%	1/10W			
R515	1-216-115-00	METAL GLAZE	560K	5%	1/10W			
R516	1-216-093-00	METAL GLAZE	68K	5%	1/10W			
R517	1-216-097-00	METAL GLAZE	100K	5%	1/10W			
R518	1-216-121-00	METAL GLAZE	1M	5%	1/10W			
R519	1-216-095-00	METAL GLAZE	82K	5%	1/10W			
R520	1-216-095-00	METAL GLAZE	82K	5%	1/10W			
R521	1-216-081-00	METAL GLAZE	22K	5%	1/10W			
R522	1-216-097-00	METAL GLAZE	100K	5%	1/10W			
R523	1-216-059-00	METAL GLAZE	2.7K	5%	1/10W			
R524	1-216-114-00	METAL GLAZE	510K	5%	1/10W			
R525	1-216-073-00	METAL GLAZE	10K	5%	1/10W			
R526	1-216-089-00	METAL GLAZE	47K	5%	1/10W			
R527	1-216-673-11	METAL CHIP	8.2K	0.50%	1/10W			
R528	1-216-103-00	METAL GLAZE	180K	5%	1/10W			
R529	1-216-665-11	METAL CHIP	3.9K	0.50%	1/10W			
R530	1-216-059-00	METAL GLAZE	2.7K	5%	1/10W			
R531	1-216-121-00	METAL GLAZE	1M	5%	1/10W			
R532	1-216-672-11	METAL CHIP	7.5K	0.50%	1/10W			
R533	1-216-065-00	METAL GLAZE	4.7K	5%	1/10W			
R534	1-216-059-00	METAL GLAZE	2.7K	5%	1/10W			
R535	1-216-115-00	METAL GLAZE	560K	5%	1/10W			
R536	1-216-099-00	METAL GLAZE	120K	5%	1/10W			
R537	1-216-081-00	METAL GLAZE	22K	5%	1/10W			
R538	1-216-089-00	METAL GLAZE	47K	5%	1/10W			
R539	1-216-121-00	METAL GLAZE	1M	5%	1/10W			
R540	1-216-081-00	METAL GLAZE	22K	5%	1/10W			
R541	1-216-047-00	METAL GLAZE	820	5%	1/10W			
R542	1-216-101-00	METAL GLAZE	150K	5%	1/10W			
R543	1-216-101-00	METAL GLAZE	150K	5%	1/10W			
R544	1-216-057-00	METAL GLAZE	2.2K	5%	1/10W			
R545	1-216-083-00	METAL GLAZE	27K	5%	1/10W			
R546	1-216-748-11	METAL GLAZE	39K	5%	1/10W			
R547	1-216-133-00	METAL GLAZE	3.3M	5%	1/10W			
R548	1-216-065-00	METAL GLAZE	4.7K	5%	1/10W			
R549	1-216-121-00	METAL GLAZE	1M	5%	1/10W			
R550	1-216-057-00	METAL GLAZE	2.2K	5%	1/10W			
R551	1-216-057-00	METAL GLAZE	2.2K	5%	1/10W			
R552	1-216-061-00	METAL GLAZE	3.3K	5%	1/10W			
R553	1-216-057-00	METAL GLAZE	2.2K	5%	1/10W			
R554	1-216-049-00	METAL GLAZE	1K	5%	1/10W			
R601	1-216-089-00	METAL GLAZE	47K	5%	1/10W			
R602	1-216-097-00	METAL GLAZE	100K	5%	1/10W			
R603	1-216-089-00	METAL GLAZE	47K	5%	1/10W			
R801	1-216-079-00	METAL GLAZE	18K	5%	1/10W			
R802	1-216-081-00	METAL GLAZE	22K	5%	1/10W			
R803	1-216-081-00	METAL GLAZE	22K	5%	1/10W			
R804	1-216-081-00	METAL GLAZE	22K	5%	1/10W			
R805	1-216-089-00	METAL GLAZE	47K	5%	1/10W			
R806	1-216-089-00	METAL GLAZE	47K	5%	1/10W			
R807	1-216-109-00	METAL GLAZE	330K	5%	1/10W			
R808	1-216-041-00	METAL GLAZE	470	5%	1/10W			
R809	1-216-009-00	METAL GLAZE	22	5%	1/10W			
R811	1-216-049-00	METAL GLAZE	1K	5%	1/10W			
R813	1-216-049-00	METAL GLAZE	1K	5%	1/10W			
R814	1-216-661-11	METAL CHIP	2.7K	0.50%	1/10W			
R815	1-216-033-00	METAL GLAZE	220	5%	1/10W			
R816	1-216-095-00	METAL GLAZE	82K	5%	1/10W			
R817	1-216-695-11	METAL CHIP	68K	0.50%	1/10W			
R818	1-216-662-11	METAL CHIP	3K	0.50%	1/10W			
R819	1-216-655-11	METAL CHIP	1.5K	0.50%	1/10W			
R820	1-216-655-11	METAL CHIP	1.5K	0.50%	1/10W			
R821	1-216-689-11	METAL CHIP	39K	0.50%	1/10W			
R822	1-216-679-11	METAL CHIP	15K	0.50%	1/10W			
R823	1-216-121-00	METAL GLAZE	1M	5%	1/10W			
R824	1-216-081-00	METAL GLAZE	22K	5%	1/10W			
R825	1-216-033-00	METAL GLAZE	220	5%	1/10W			
R826	1-216-683-11	METAL CHIP	22K	0.50%	1/10W			
R827	1-216-081-00	METAL GLAZE	22K	5%	1/10W			
R828	1-216-097-00	METAL GLAZE	100K	5%	1/10W			
R829	1-216-033-00	METAL GLAZE	220	5%	1/10W			
R830	1-216-129-00	METAL GLAZE	2.2M	5%	1/10W			
R831	1-216-097-00	METAL GLAZE	100K	5%	1/10W			
R832	1-216-081-00	METAL GLAZE	22K	5%	1/10W			
R833	1-216-073-00	METAL GLAZE	10K	5%	1/10W			
R834	1-216-109-00	METAL GLAZE	330K	5%	1/10W			
R835	1-216-049-00	METAL GLAZE	1K	5%	1/10W			
R836	1-216-121-00	METAL GLAZE	1M	5%	1/10W			
R837	1-216-129-00	METAL GLAZE	2.2M	5%	1/10W			



REVISED

Ref.No.	Part No.	Description
R838	1-216-073-00	METAL GLAZE 10K 5% 1/10W
R839	1-216-121-00	METAL GLAZE 1M 5% 1/10W
RV301	1-230-485-11	RES. VAR. CARBON 10K/10K (VOLUME)
RV401	1-241-094-11	RES. ADJ. CERMET 4.7K (5V)
RV402	1-241-092-11	RES. ADJ. CERMET 1K (3.4V)
RV450	1-241-094-11	RES. ADJ. CERMET 4.7K (3.6V)
RV501	1-241-094-11	RES. ADJ. CERMET 4.7K (TRACKING GAIN)
RV502	1-241-096-11	RES. ADJ. CERMET 22K (TRACKING BALANCE)
RV503	1-241-097-11	RES. ADJ. CERMET 47K (FOCUS BIAS)
RV504	1-241-092-11	RES. ADJ. CERMET 1K (PLL)
RV505	1-241-097-11	RES. ADJ. CERMET 47K (FOCUS GAIN)
RV801	1-241-095-11	RES. ADJ. CERMET 10K (BATTERY DISPLAY)
S301	1-571-506-41	SWITCH, SLIDE (DBB)
S801	1-554-371-51	SWITCH, TACT (□)
S802	1-554-371-51	SWITCH, TACT (▷□□)
S804	1-571-484-11	SWITCH, KEY BOARD (MODE)(REMAIN)
S806	1-554-371-51	SWITCH, TACT (▷▷)
S807	1-554-371-51	SWITCH, TACT (◀◀)
S808	1-571-860-11	SWITCH, SLIDE (HOLD)(RESUME)
S901	1-570-953-11	SWITCH, PUSH (1 KEY)(DOOR)
S902	1-571-099-11	SWITCH (LIMIT SW)
X331	1-579-045-11	VIBRATOR, CERAMIC (33.9MHz)
X801	1-578-773-11	VIBRATOR, CERAMIC (3.58MHz)

ACCESSORY & PACKING MATERIAL

△	1-463-691-11	(US).....ADAPTOR, AC (AC-930A)
△	1-463-694-11	(Canadian)...ADAPTOR, AC (AC-930A)
△	1-463-968-11	(US).....ADAPTOR, AC (AC-940)
△	1-463-700-11	(UK).....ADAPTOR, AC (AC-930A)
△	1-463-702-11	(E).....ADAPTER, AC (AC-950W)
△	1-463-705-11	(AEP).....ADAPTER, AC (AC-930AEP)
△	1-526-565-00	(E).....AC PLUG ADAPTER
	1-528-297-11	(US,E,Canadian,UK)..BATTERY PACK(BP-2EX)
	1-528-297-21	(AEP,WG).....BATTERY PACK(BP-2EX)
	1-555-658-21	CORD, CONNECTION (RK-G129)
	1-575-145-11	CORD, CONNECTION (CN2/3P)
	3-751-684-11	(E,AEP,UK,Canadian)...MANUAL, INSTRUCTION (ENGLISH/FRENCH/SPANISH/PORTUGUESE)
	3-751-684-21	(US).....MANUAL, INSTRUCTION (ENGLISH)
	3-751-684-41	(WG,AEP)...MANUAL, INSTRUCTION (GERMAN/DUTCH/SWEDISH/ITALIAN)
*4	920-407-01	BAG, PROTECTION
*4	930-139-01	CUSHION (UPPER)
*4	930-140-01	(US,E,Canadian)...CUSHION (LOWER)
*4	930-162-02	(UK,WG).....CUSHION (LOWER)
	4-930-155-01	CASE, CARRYING
*4	931-805-01	(US,E,Canadian)...INDIVIDUAL CARTON
*4	931-806-01	(AEP).....INDIVIDUAL CARTON
*4	931-808-01	(WG,UK).....INDIVIDUAL CARTON
	1-505-113-21	(WG,UK)...HEADPHONE (WITH REMOTE CONTROL)
	8-952-478-90	(E,Canadian)...HEADPHONE MDR-E472 SET
	8-953-307-90	(US,AEP).....HEADPHONE MDR-A10D SET
X	4930-117-1	CASE ASSY, BATTERY

Note:

The components identified by mark  or dotted line with mark  are critical for safety. Replace only with part number specified.

Note:

Les composants identifiés par une marque  sont critiques pour la sécurité. Ne les remplacer que par une pièce portant le numéro spécifié.

9-955-745-11

[Including 9-955-745-91]
9-955-745-92]

Sony Corporation
General Audio Group