



Battery Power Applications Design Guide

Powering Your Portable Design



Power Management

Design ideas in this guide are based on many of Microchip's Power Management products. A complete device list and corresponding data sheets for these products can be found at www.microchip.com.

DC/DC CONVERSION

Linear Regulators

Closed loop control with linear regulators. Often the voltage source is “incompatible” with the load. A buffer needs to be placed between the source and load to regulate or control the voltage and/or current.

Linear regulators provide closed loop control to “regulate” the voltage at the load. A basic linear regulator has three main components: an operational amplifier, a voltage reference and a pass transistor. The main purpose of a linear regulator is to produce a constant, accurate output voltage at a lower magnitude than the input voltage.

Beyond the basics, linear regulators often offer additional features: overcurrent protection, thermal protection and reversed polarity protection to name a few.

Microchip offers a line of CMOS, low dropout linear regulators. A low dropout regulator is a type of linear regulator designed to minimize the saturation voltage of the output transistor and to minimize the gate drive requirements. LDOs can operate with a very small input to output differential.

MCP1702 Linear Regulator Features:

- 2.0 μA Typical Quiescent Current
- Input Operating Voltage Range: 2.7V to 13.2V
- Low Dropout Voltage:
 - 650 mV (typ.) @ 250 mA ($V_{\text{OUT}} = 2.5\text{V}$)
- 250 mA Output Current for Output Voltages $\geq 2.5\text{V}$
- 200 mA Output Current for Output Voltages $< 2.5\text{V}$
- High-Accuracy Output Voltage: $\pm 2\%$ (max.)
- Low Temperature Drift: ± 100 ppm/ $^{\circ}\text{C}$ (typ.)
- Excellent Line Regulation: 0.2%/V (typ.)
- Package Options: 3-pin SOT-23A, 3-pin SOT-89 and 3-pin T0-92
- Short Circuit Protection and Thermal Shutdown Protection
- Stable with 1.0 μF to 22 μF Output Capacitance

MCP1702 Linear Regulator

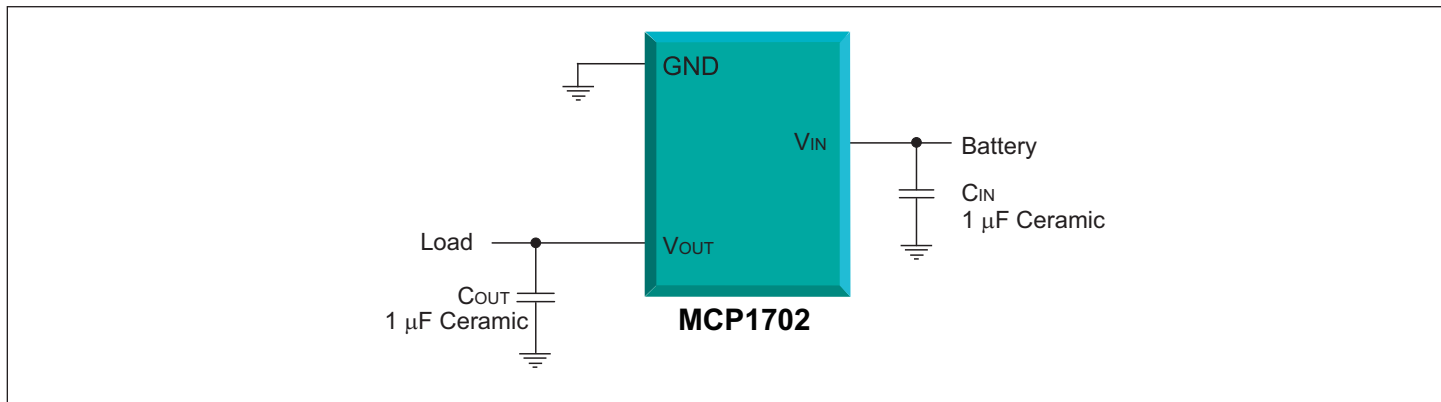

Selected Product Specifications: Linear Regulators

Device	Max. Input Voltage	Output Voltage (V)	Output Current (mA)	Typical Active Current (μA)	Typical Dropout Voltage @ Max. I_{OUT} (mV)	Features	Packages
TC1016	6.0	1.8-3.0	80	50	150	Shutdown	5-pin SC-70
TC1017	6.0	1.8-4.0	150	53	285	Shutdown	5-pin SC-70/SOT-23A
MCP1700	6.0	1.2-5.0	250	1.6	178	Shutdown, Power good output with adjustable delay	3-pin SOT-23A/SOT-89, 3-pin T0-92
MCP1702	13.2	1.2-5.0	250 for output voltages $\geq 2.5\text{V}$ 200 for output voltages $< 2.5\text{V}$	2	650	Shutdown, Power good output with adjustable delay	3-pin SOT-23A, 3-pin SOT-89, T0-92-3
MCP1725	6.0	0.8-5.0	500	120	210	Shutdown, Power good output with adjustable delay	8-pin 2x3 DFN and SOIC-8 Pb-free
MCP1726	6.0	0.8-5.0	1000	140	250	Shutdown, Power good output with adjustable delay	8-pin 3x3 DFN and SOIC-8 Pb-free
MCP1727	6.0	0.8-5.0	1000	140	330	Shutdown, Power good output with adjustable delay	8-pin 3x3 DFN and SOIC-8 Pb-free
MCP1827/ MCP1827S	6.0	0.8-5.0	1500	120	330	Shutdown, Power good	DDPAK-5 and T0-220-5 Pb-free
TC2014	6.0	1.8-3.3	50	55	45	Shutdown, Reference bypass input	5-pin SOT-23A
TC2015	6.0	1.8-3.3	100	55	90	Shutdown, Reference bypass input	5-pin SOT-23A
TC2185	6.0	1.8-3.3	150	55	140	Shutdown, Reference bypass input	5-pin SOT-23A
TC2186	6.0	1.8-3.3	150	55	140	Shutdown, Error output	5-pin SOT-23A

DC/DC CONVERSION

Switch-mode Power Converter

Employing a switch-mode power converter. Another approach to transferring the battery energy to the system load is to employ a switch-mode power converter. The primary advantage of a switch-mode power converter is that it can, ideally, accomplish power conversion and regulation at 100% efficiency. All power loss is due to non-ideal components and power loss in the control circuit.

The buck converter is an inductor based switch-mode power converter used to step-down an input source to a lower magnitude output. The buck converter goes by many names: voltage step-down converter, DC-to-DC converter, chopper converter, etc. No matter what the name, inductor based, buck derived, switch-mode converters account for 80% to 90% of all converters sold.

Microchip offers inductor based buck regulators and controllers. The distinction is whether or not the switch (MOSFET) is internal to the device (regulator) or controlled externally (controller). The schematic represented here depicts a MCP1601 buck regulator with its associated external components.

TC1303B Synchronous Buck Regulator + LDO Features:

- Dual-Output Regulator (500 mA Buck Regulator and 300 mA Low-Dropout Regulator)
- Power-Good Output with 300 ms Delay
- Total Device Quiescent Current = 65 μ A (Typical)
- Independent Shutdown for Buck and LDO Outputs
- Both Outputs Internally Compensated
- Synchronous Buck Regulator:
 - Typical Efficiency: Over 90%
 - 2.0 MHz Fixed-Frequency PWM (Heavy Load)
 - Low Output Noise
 - Automatic PWM/PFM Mode Transition
 - Adjustable (0.8-4.5V) and Standard Fixed-Output Voltages (0.8V, 1.2V, 1.5V, 1.8V, 2.5V, 3.3V)
- Low-Dropout Regulator:
 - Low-Dropout Voltage = 137 mV (Typical @ 200 mA)
 - Standard Fixed-Output Voltages (1.5V, 1.8V, 2.5V, 3.3V)
- Power-Good Function: TC1303B Monitors LDO Output
- Small 10-pin 3x3 DFN or MSOP Package Options
- Operating Junction Temperature Range: -40 $^{\circ}$ C to +125 $^{\circ}$ C
- UVLO (Under Voltage Lock Out)
- Output Short Circuit Protection
- Overtemperature Protection
- Excellent Bluetooth Applications

TC1303B Synchronous Buck Regulator

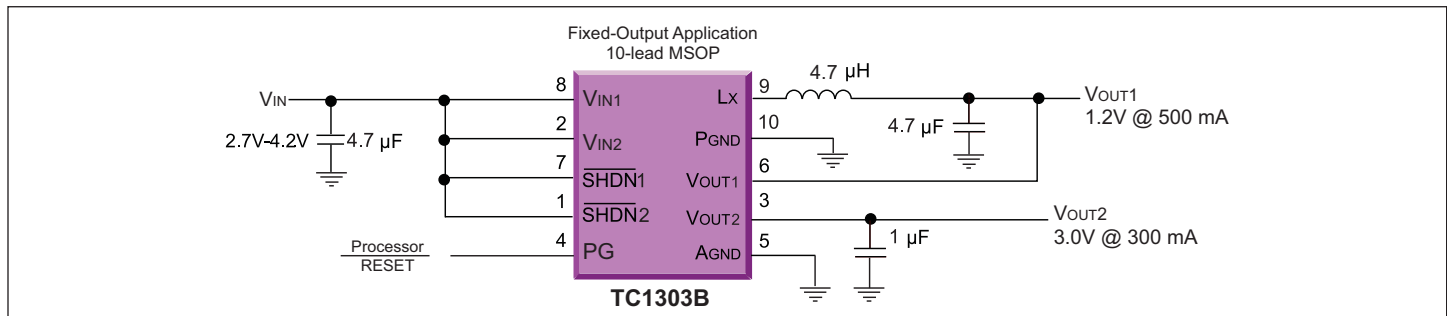

Selected Product Specifications: Switching Regulators/Controllers

Device	Output	Buck/Boost	Input Voltage Range (V)	Output Voltage (V)	Control Scheme	Features	Packages
MCP1601	Adjustable	Step-Down	2.7-5.5	0.9 to V_{IN}	PWM/PFM/LDO	UVLO, Auto switching, LDO	8-pin MSOP
MCP1603	Fixed or Adjustable	Step-Down	2.7-5.5	0.8-4.5	PFM/PWM	UVLO, Automatic PWM to PFM Mode Transition, Overtemperature Protection, Low Quiescent Current, Low Shutdown Current	5-pin TSOT 8-pin 2x3 DFN
MCP1612	Adjustable	Step-Down	2.7-5.5	0.8-5.5	PWM	UVLO, Soft-start, 1.4 MHz, 1A	8-pin MSOP/DFN
TC105	Fixed	Step-Down	2.2-10	3.0-5.0	PFM/PWM	Low-power Shutdown mode	5-pin SOT-23A
TC110	Fixed	Step-Up	2.0-10	3.0-5.0	PFM/PWM	Soft-start, Low-power Shutdown mode	5-pin SOT-23A
TC115	Fixed	Step-Up	0.9-10	3.0-5.0	PFM/PWM	Feedback voltage sensing, Low-power Shutdown mode	5-pin SOT-89
TC120	Fixed	Step-Down	1.8-10	3.0-5.0	PFM/PWM	Soft-start, Low-power Shutdown mode	8-pin SOP
TC1303A/B/C	Fixed or Adjustable	Step-Down	2.7-5.5	0.8-4.5	PFM/PWM	UVLO, Overtemperature Protection, Output Short Circuit Protection, Power-Good, Independent Shut down, Synchronous Buck + LDO	10-pin DFN 10-pin MSOP
TC1304	Fixed or Adjustable	Step-Down	2.7-5.5	0.8-4.5	PFM/PWM	UVLO, Overtemperature Protection, Output Short Circuit Protection, Power-Good, Synchronous Buck + LDO, Sequenced Startup and Shutdown	10-pin DFN 10-pin MSOP
TC1313	Fixed or Adjustable	Step-Down	2.7-5.5	0.8-4.5	PFM/PWM	UVLO, Output Short Circuit Protection, Overtemperature Protection, Independent Shutdown for Buck and LDO Outputs	10-pin DFN 10-pin MSOP

DC/DC CONVERSION

MCP1603 Synchronous Buck Regulator

The MCP1603 is a highly efficient, fully integrated 500 mA synchronous buck regulator whose 2.7V to 5.5V input voltage range makes it ideally suited for applications powered from 1-cell Li-Ion or 2-cell/3-cell NiMH/NiCd batteries. At heavy loads, the MCP1603 operates in the 2.0 MHz fixed frequency PWM mode which provides a low noise, low output ripple, small-size solution. When the load is reduced to light levels, the MCP1603 automatically changes operation to a PFM mode to minimize quiescent current draw from the battery. No intervention is necessary for a smooth transition from one mode to another. These two modes of operation allow the MCP1603 to achieve the highest efficiency over the entire operating current range. The MCP1603 is available with either an adjustable or fixed output voltage. The available fixed output voltage options are 1.2V, 1.5V, 1.8V, 2.5V and 3.3V. When a fixed option is used, only three additional small external components are needed to form a complete solution. Couple this with the low profile, small foot print packages and the entire system solution is achieved with minimal size. Additional protection features include: UVLO, overtemperature and overcurrent protection.

MCP1603 Synchronous Buck Regulator Features:

- Over 90% Typical Efficiency
- Output Current Up To 500 mA
- Low Quiescent Current = 45 μ A, typical
- Low Shutdown Current = 0.1 μ A, typical
- Adjustable Output Voltage:
 - 0.8V to 4.5V
- Fixed Output Voltage:
 - 1.2V, 1.5V, 1.8V, 2.5V, and 3.3V
- 2.0 MHz Fixed-Frequency PWM (Heavy Load)
- Automatic PWM to PFM Mode Transition
- 100% Duty Cycle Operation
- Internally Compensated
- Undervoltage Lockout (UVLO)
- Overtemperature Protection
- Space Saving Packages:
 - 5-lead TSOT
 - 8-pin 2x3 DFN

Applications:

- Cellular Telephones
- Portable Computers
- Organizers/PDAs
- USB Powered Devices
- Digital Cameras
- Portable Equipment
- +5V or +3.3V Distributed Systems

MCP1603 Synchronous Buck Regulator

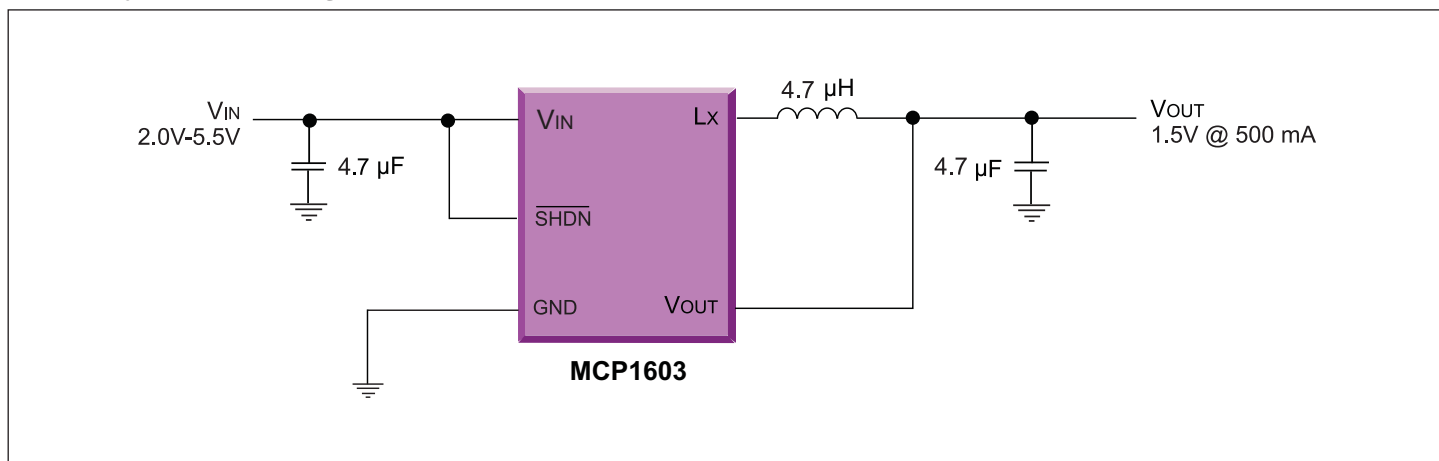

LI-ION BATTERY MANAGEMENT

Li-Ion Battery Charge Management Control

Linear charge management control. Far too often, the battery charging system is given low priority, especially in cost sensitive applications. However, the quality of the charging system plays a key role in the life and reliability of the battery.

Microchip offers a complete line of linear Li-Ion battery chargers. The Li-Ion Charge Management Controllers provide a reliable, low-cost and high accuracy voltage regulation solution with few external components. In an effort to further reduce the size, cost and complexity. The MCP7383X family provides fully integrated charge management controllers for single-cell Li-Ion and Li-Polymer batteries with four voltage regulation options (4.2V, 4.35V, 4.40V, 4.50V) available.

In order to supply world-class portable devices, most of Microchip's Li-Ion Battery Management Controllers are equipped with thermal regulation, reverse discharge protection, safety charge timer and integrated current sensing. The programmable constant charge current can assist customers in meeting different applications with a single resistor. Along with their small physical size, the low number of external components required makes Microchip's battery management ICs ideally suited for portable applications.

MCP73832 Battery Charger Features:

- Linear Charge Management Controller
- Integrated Pass Transistor
- Integrated Current Sense
- Reverse Discharge Protection
- High Accuracy Preset Voltage Regulation: +0.75%
- Four Voltage Regulation Options:
 - 4.20V, 4.35V, 4.40V and 4.50V
- Programmable Charge Current
- Selectable Preconditioning
- Selectable End-of-Charge Control
- Charge Status Output
- Automatic Power-Down
- Thermal Regulation
- Temperature Range: -40°C to +85°C
- Packaging:
 - 8-pin 2x3 DFN
 - 5-lead SOT-23

Additional MCP73833 Battery Charger Features:

- Programmable Charge Current: 1A Maximum
- Two Charge Status Outputs
- Low-Dropout Linear Regulator Mode
- Numerous Selectable Options Available for a Variety of Applications
- Available Packages:
 - 10-pin 3x3 DFN
 - MSOP-10

Regulated 3.3V, Low-Ripple Charge Pump with Low-Operating Current Sleep Mode or Bypass Mode

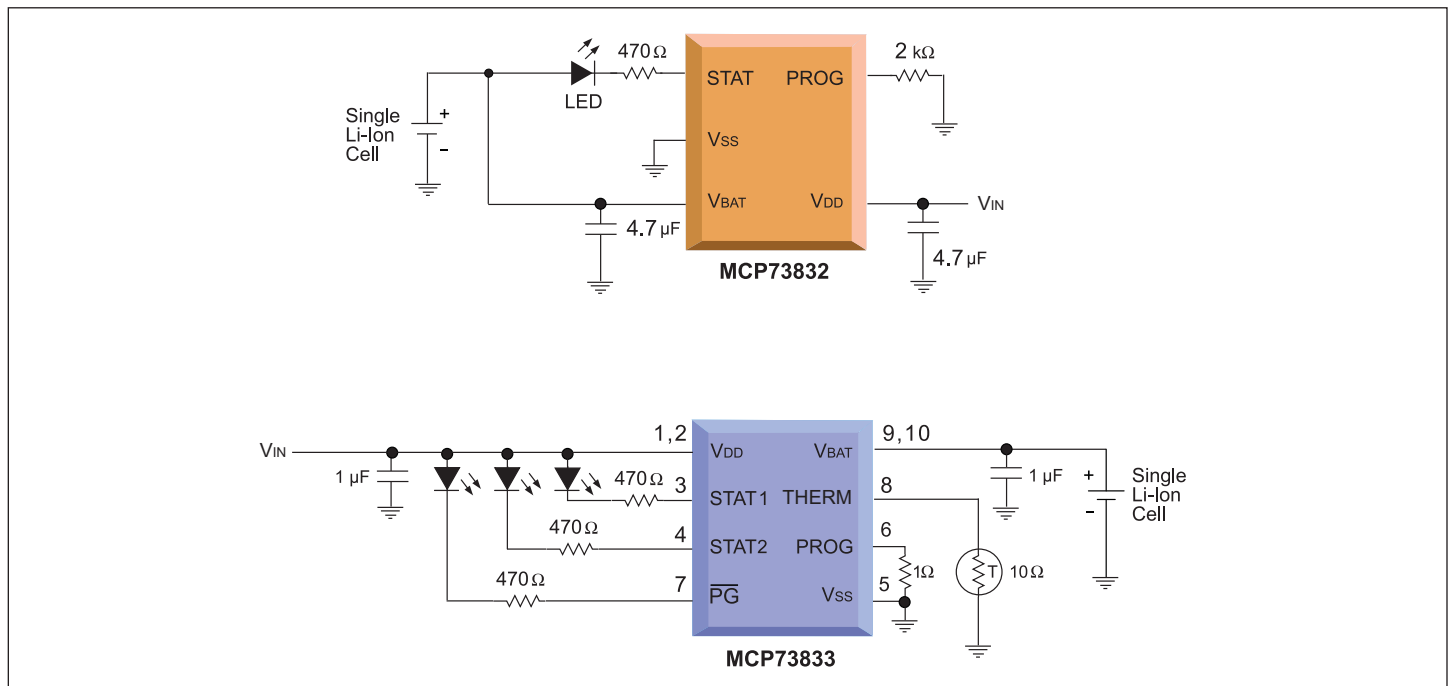

LI-ION BATTERY MANAGEMENT

Selected Product Specifications: Battery Charger Family

Device	Mode	# of Cells	Vcc Range (V)	Max. Voltage Regulation	Int/Ext FET	Features
MCP73811	Linear	1	3.75-6	±1.0%	Int	USB Selectable Charge Current, Thermal Regulation, Automatic Power-Down, Charge Enable
MCP73812	Linear	1	3.75-6	±1.0%	Int	Programmable Charge Current, Thermal Regulation, Automatic Power-Down, Charge Enable
MCP73826	Linear	1	4.5-5.5	±1.0%	Ext	Small size
MCP73827	Linear	1	4.5-5.5	±1.0%	Ext	Mode indicator, charge current monitor
MCP73828	Linear	1	4.5-5.5	±1.0%	Ext	Temperature monitor
MCP73831	Linear	1	3.75-6	±.75%	Int	Programmable charge current, thermal regulation, UVLO, Preconditioning and end-of-charge ratio options
MCP73832	Linear	1	3.75-6	±.75%	Int	Programmable charge current, thermal regulation, UVLO, Preconditioning and end-of-charge ratio options
MCP73833	Linear	1	3.75-6	±.75%	Int	Programmable charge current, thermal regulation, UVLO, Preconditioning and end-of-charge ratio options
MCP73834	Linear	1	3.75-6	±.75%	Int	Programmable charge current, thermal regulation, UVLO, Preconditioning and end-of-charge ratio options
MCP73841	Linear	1	4.5-12	±0.5%	Ext	Safety charge timers, temperature monitor
MCP73842	Linear	2	8.7-12	±0.5%	Ext	Safety charge timers, temperature monitor
MCP73843	Linear	1	4.5-12	±0.5%	Ext	Safety charge timers
MCP73844	Linear	2	8.7-12	±0.5%	Ext	Safety charge timers
MCP73853	Linear	1	4.5-5.5	±0.5%	Int	USB control, safety charge timers, temperature monitor, thermal regulation
MCP73855	Linear	1	4.5-5.5	±0.5%	Int	USB control, safety charge timers, thermal regulation
MCP73861	Linear	1	4.5-12	±0.5%	Int	Safety charge timers, temperature monitor, thermal regulation
MCP73862	Linear	2	8.7-12	±0.5%	Int	Safety charge timers, temperature monitor, thermal regulation
MCP73863	Linear	1	4.5-12	±0.5%	Int	Programmable safety charge timer, temperature monitor, thermal regulation, programmable charge current, auto recharge, status and fault indicator
MCP73864	Linear	2	8.7-12	±0.5%	Int	Programmable safety charge timer, temperature monitor, thermal regulation, programmable charge current, auto recharge, status and fault indicator

LI-ION BATTERY MANAGEMENT

Intelligent Power Control Systems

Intelligent, switch-mode charge management control.

The MCP1630 is a high-speed, microcontroller-adaptable, Pulse-Width Modulator (PWM) used to develop intelligent power control systems. Combined with a microcontroller, the MCP1630 regulates output voltage or current by controlling the power-system duty cycle. In the power control system, the microcontroller can be used to digitally adjust the output voltage or current by controlling the voltage reference applied to the MCP1630; thereby bringing digital control to the analog PWM function.

The fast comparator of the MCP1630 enables this device to be used as an excellent current mode controller. With a typical response time of 12 ns, the MCP1630 comparator provides a very tight limit to the maximum switch current over a wide range of input voltages.

MCP1630 PWM Features:

- High-Speed PWM Operation:
 - 12 ns Current Sense to Output Delay
- Operating Temperature Range: -40°C - +125°C
- Precise Peak Current Limit: ±5%
- CMOS Output Driver (Drives MOSFET Driver or Low-Side N-channel MOSFET Directly)
- External Oscillator Input (from PIC® Microcontroller)
- External Voltage Reference Input (for Adjustable Voltage or Current Output Application)
- Peak Current Mode Operation to 1 MHz
- Low Operating Current: 2.8 mA, typical
- Fast Output Rise and Fall Times: 5.9 ns, 6.2 ns
- Under-voltage Lockout
- Output Short Circuit Protection
- Overtemperature Protection

Switch-mode, Li-Ion Battery Charger Circuits

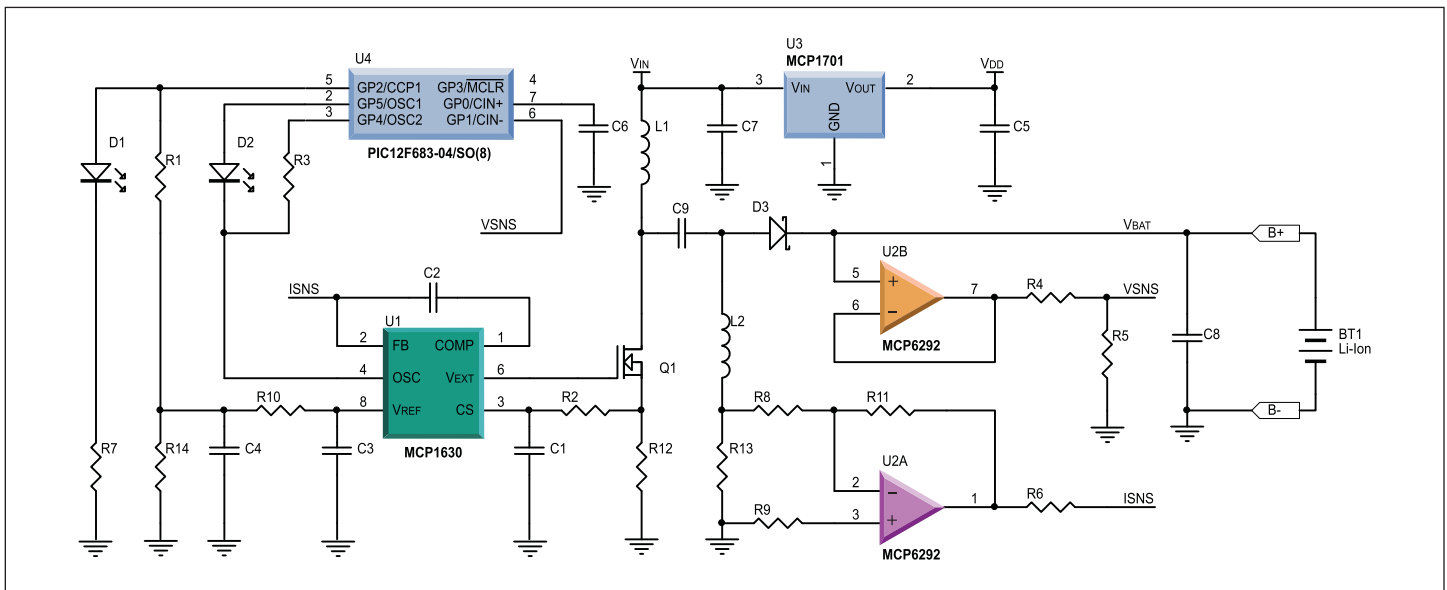

Selected Product Specifications: MCP1630 PWM Controller

Device	Input Voltage Range (V)	Current Sense-to-Output Delay	Control Scheme	Ext. Oscillator Range	Operating Temperature Range	Packages
MCP1630	3.0-5.5	12 ns typ.	Cycle-by-Cycle Peak Current Control	1.0 MHz	-40°C to +125°C	8-pin MSOP

Selected Product Specifications: PIC12F683 Microcontroller

Device	Bytes	OTP/Flash Words	RAM Bytes	I/O Pins	8-bit ADC Channels	Comparators	Timers/WDT	Max. Speed MHz	Other Features	Packages
PIC12F683	3584	2048	128	6	4 x 10-bit	1	1 16-bit, 2 8-bit, 1 WDT	20	Internal 8 MHz oscillator	8-pin PDIP/SOIC/DFN

Selected Product Specifications: MCP6292 Op Amp

Device	# Per Package	GBWP	Iq Typ. (µA)	Vos Max. (mV)	Operating Voltage (V)	Packages
MCP6292	2	10 MHz	1000	3	2.4-5.5	8-pin PDIP/SOIC/MSOP

Selected Product Specifications: MCP1702 Low Dropout Positive Voltage Regulator

Device	Max. Input Voltage (V)	Output Voltage (V)	Output Current (mA)	Typ. Active Current (µA)	Typ. Dropout Voltage (mV)	Packages
MCP1702	13.2	1.2-5.0	200-250	2	650	3-pin SOT-23A/SOT-89/TO-92

BACKLIGHTING

Biased Backlighting

The MCP1252-ADJ is an inductorless, positive-regulated charge pump DC/DC converter. The device generates an adjustable output voltage. It is specifically designed for applications requiring low noise and high efficiency and is able to deliver up to 120 mA output current. The device allows the input voltage to be lower or higher than the output voltage, by automatically switching between buck/boost operation.

Today's new color displays require a pure white light for backlighting. White light emitting diodes have become the component of choice. The MCP1252-ADJ is an excellent choice for biasing the backlighting. Light intensity is controlled uniformly through the use of ballast resistors. The peak intensity is set by the feedback to the MCP1252-ADJ. Dimming is accomplished by pulse-width modulating the shutdown pin of the device.

MCP1252 Charge Pump Features:

- Inductorless, Buck/Boost, DC/DC Converter
- Low Power: 80 μ A (Typical)
- 120 mA Output Current
- Wide Operating Temperature Range: -40°C to +85°C
- Thermal Shutdown and Short-Circuit Protection
- Uses Small Ceramic Capacitors
- Low Power Shutdown Mode: 0.1 μ A (Typical)
- Shutdown Input Compatible with 1.8V Logic
- V_{IN} Range: 2.0V to 5.5V

White LED Backlighting Circuit with Regulated Charge Pump

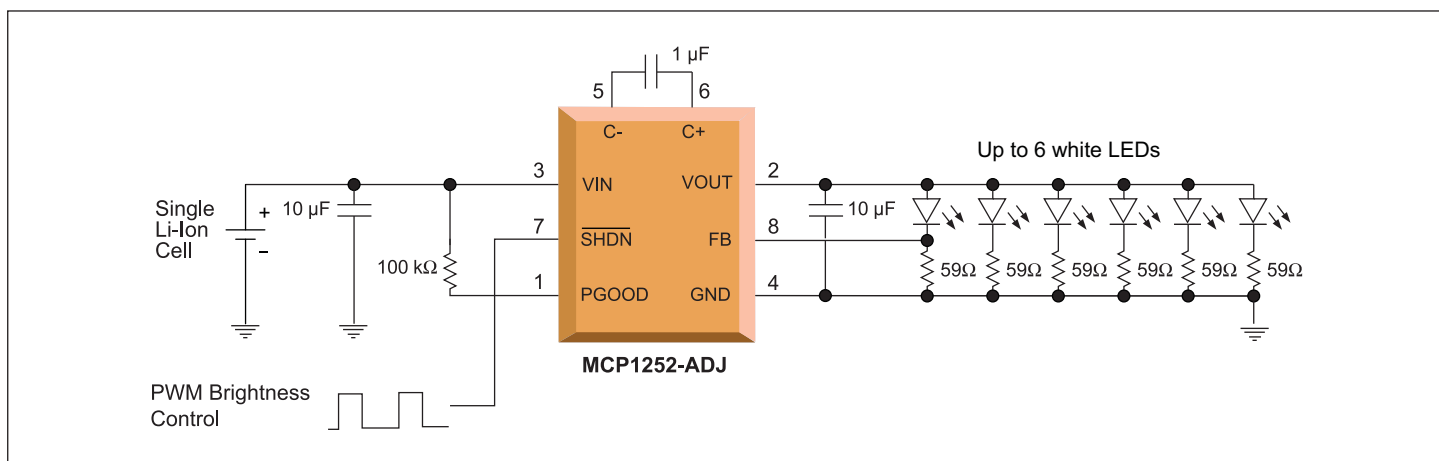

Selected Product Specifications: Regulated Charge Pump DC/DC Converters

Device	Input Voltage Range (V)	Output Voltage (V)	Max. Input Current (μ A)	Typical Active Output Current (mA)	Features	Packages
MCP1252-33X50	2.7-5.5	Selectable 3.3-5.0V	120	120 mA for $V_{IN}>3.0V$	Power-Good output, 650 kHz oscillator	8-pin MSOP
MCP1252-ADJ	2.0-5.5	Adjustable 1.5V-5.5V	120	120 mA for $V_{IN}>3.0V$	Power-Good output, 650 kHz oscillator	8-pin MSOP
MCP1253-33X50	2.7-5.5	Selectable 3.3-5.0V	120	120 mA for $V_{IN}>3.0V$	Power-Good output, 1 MHz oscillator	8-pin MSOP
MCP1253-ADJ	2.0-5.5	Adjustable 1.5V-5.5V	120	120 mA for $V_{IN}>3.0V$	Power-Good output, 1 MHz oscillator	8-pin MSOP
MCP1256	1.8-3.6	3.3	10	100mA	Power Good Output, Inductorless 1.5x, 2x dual mode, Thermal Shutdown and Short Circuit Protection	10-pin MSOP and 10-pin 3x3 DFN
MCP1257	1.8-3.6	3.3	10	100mA	Power Good Output, Inductorless 1.5x, 2x dual mode, Thermal Shutdown and Short Circuit Protection	10-pin MSOP and 10-pin 3x3 DFN
MCP1258	1.8-3.6	3.3	10	100mA	Power Good Output, Inductorless 1.5x, 2x dual mode, Thermal Shutdown and Short Circuit Protection	10-pin MSOP and 10-pin 3x3 DFN
MCP1259	1.8-3.6	3.3	10	100mA	Power Good Output, Inductorless 1.5x, 2x dual mode, Thermal Shutdown and Short Circuit Protection	10-pin MSOP and 10-pin 3x3 DFN

Microchip also offers inverting or doubling charge pumps, multi-function charge pumps and inverting and doubling charge pumps. See the Microchip web site for complete specifications www.microchip.com.

BACKLIGHTING

MCP1256/7/8/9 Regulated 3.3V, Low-Ripple Charge Pump with Low-Operating Current Sleep Mode or Bypass Mode

The MCP1256, MCP1257, MCP1258 and MCP1259 are inductorless, positive regulated charge pump DC/DC converters. The devices generate a regulated 3.3V output voltage from a 1.8V to 3.6V input. The devices are specifically designed for applications operating from 2-cell alkaline, Ni-Cd, or Ni-MH batteries or by one primary lithium MnO₂ (or similar) coin cell battery.

The MCP1256, MCP1257, MCP1258 and MCP1259 provide high efficiency by automatically switching between 1.5x and 2x boost operation. In addition, at light output loads, the MCP1256 and MCP1257 can be placed in a Sleep mode, lowering the quiescent current while maintaining the regulated output voltage. Alternatively, the MCP1258 and MCP1259 provide a Bypass feature connecting the input voltage to the output. This allows for real-time clocks, microcontrollers or other system devices to remain biased with virtually no current being consumed by the MCP1258 or MPC1259. In normal operation, the output voltage ripple is below 20 mVPP at load currents up to 100 mA. Normal operation occurs at a fixed switching frequency of 650 kHz, avoiding interference with sensitive IF bands.

The MCP1256 and MCP1258 feature a power-good output that can be used to detect out-of-regulation conditions. The MCP1257 and MCP1259 feature a low battery indication that issues a warning if the input voltage drops below a preset voltage threshold.

Extremely low supply current and few external parts (4 capacitors) make these devices ideal for small, battery powered applications. A Shutdown mode is also provided for further power reduction. The devices incorporate thermal and short-circuit protection. Two packages are offered: 10-pin MSOP and 10-pin 3x3 DFN. The devices are completely characterized over the junction temperature range of -40°C to +125°C.

MCP1256/7/8/9 Charge Pump Features:

- Inductorless 1.5x, 2x Boost DC/DC Converter
- Output Voltage: 3.3V
- High Output Voltage Accuracy:
 - ±3.0% (V_{OUT} Fixed)
- Output Current Up To 100 mA
- 20m V_{PP} Output Voltage Ripple
- Thermal Shutdown and Short Circuit Protection
- Uses Small Ceramic Capacitors
- Switching Frequency: 650 kHz
- Low-Power Sleep Mode: MCP1256/7
- Bypass Mode: MCP1258/9
- Low-Power Shutdown Mode: 0.1 μA (Typical)
- Shutdown Input Compatible with 1.8V Logic
- V_{IN} Range: 1.8V to 3.6V
- Soft-Start Circuitry to Minimize Inrush Current
- Temperature Range: -40°C to +125°C
- Packaging:
 - 10-pin 3x3 DFN
 - 10-pin MSOP

Regulated 3.3V, Low-Ripple Charge Pump with Low-Operating Current Sleep Mode or Bypass Mode

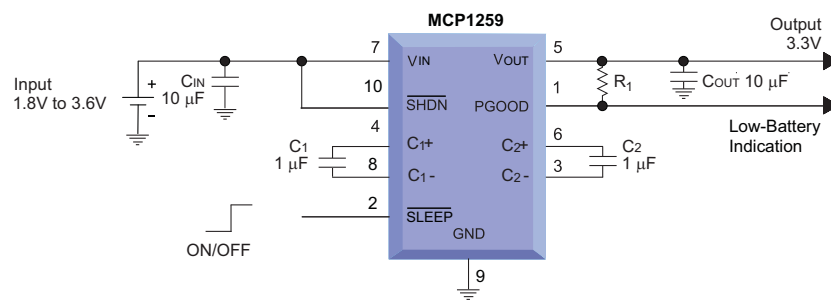
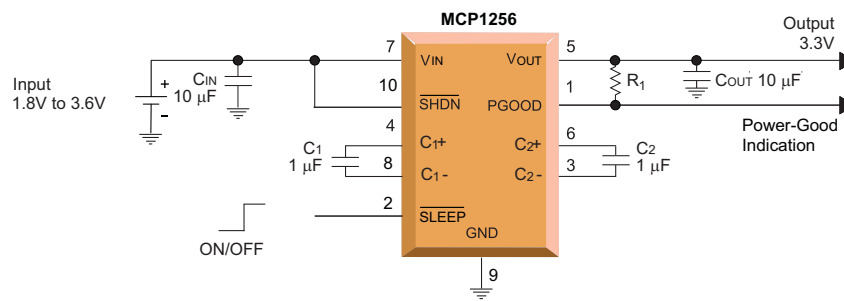

BACKLIGHTING

Driving White LED's

Driving white light emitting diodes in series. An alternative to the MCP1252 backlighting approach is to drive the white light emitting diodes in series. The series connection provides improved brightness matching between the diodes since they all operate with the same current. Light intensity is adjusted by controlling the current through the diodes. The MCP1650 is a boost controller that can be used to bias the diodes in series as depicted below.

MCP1650 Features:

- Output Power Capability Over 5 Watts
- Output Voltage Capability From 3.3V to Over 100V
- 750 kHz Gated Oscillator Switching Frequency
- Adaptable Duty Cycle for Battery or Wide-Input, Voltage-Range Applications
- Input Voltage Range: 2.0V to 5.5V
- Capable of SEPIC and Flyback Topologies
- Shutdown Control with $I_Q < 0.1 \mu A$ (Typical)
- Low Operating Quiescent Current: $I_Q = 120 \mu A$
- Voltage Feedback Tolerance (0.6%, Typical)
- Popular MSOP-8 Package
- Peak Current Limit Feature
- Two Under Voltage Lock Out (UVLO) Options: 2.0V or 2.55V
- Operating Temperature Range: $-40^\circ C$ to $+125^\circ C$

White LED Backlighting Circuit with Boost Controller

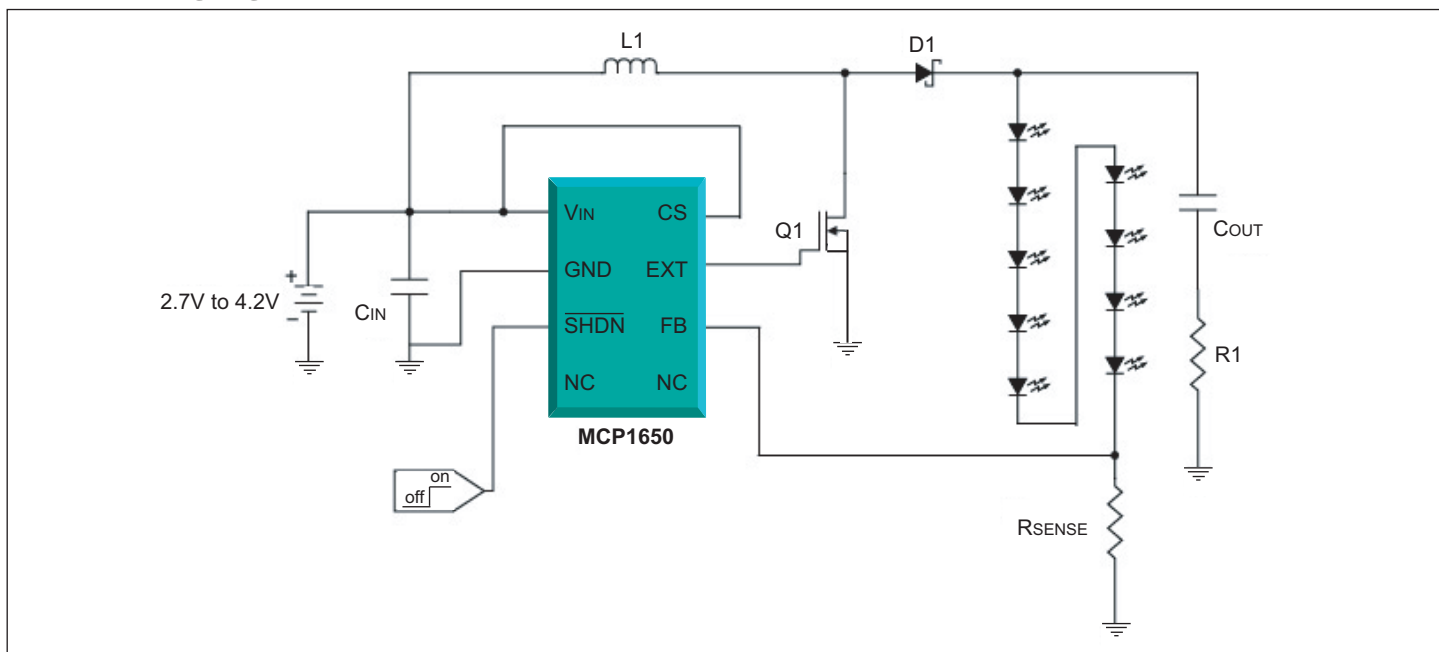

Selected Product Specifications: Boost Controllers

Device	Output	Buck/Boost	Input Voltage Range (V)	Output Voltage (V)	Control Scheme	Features	Packages
MCP1650	Adjustable	Step-Up	2.7-5.5	2.5 to Ext. Tx. Limited	Constant Frequency, 2 Fixed DC	2 Duty Cycles for Min. and Max. Loads, Shutdown, UVLO, Soft-start	8-pin MSOP
MCP1651	Adjustable	Step-Up	2.7-5.5	2.5 to Ext. Tx. Limited	Constant Frequency, 2 Fixed DC	2 Duty Cycles for Min. and Max. Loads, Shutdown, Low Battery Detect, UVLO, Soft-start	8-pin MSOP
MCP1652	Adjustable	Step-Up	2.7-5.5	2.5 to Ext. Tx. Limited	Constant Frequency, 2 Fixed DC	2 Duty Cycles for Min. and Max. Loads, Shutdown, Power Good Indicator, UVLO, Soft-start	8-pin MSOP
MCP1653	Adjustable	Step-Up	2.7-5.5	2.5 to Ext. Tx. Limited	Constant Frequency, 2 Fixed DC	2 Duty Cycles for Min. and Max. Loads, Shutdown, Low Battery Detect, Power Good Indicator, UVLO, Soft-start	10-pin MSOP

The following application notes are available on the Microchip web site: www.microchip.com.

Application Notes

AN246: *Driving the Analog Inputs of a SAR A/D Converter*

Driving any A/D Converter (ADC) can be challenging if all issues and trade-offs are not well understood from the beginning. With Successive Approximation Register (SAR) ADCs, the sampling speed and source impedance should be taken into consideration if the device is to be fully utilized. In this application note we will delve into the issues surrounding the SAR Converter's input and conversion nuances to insure that the converter is handled properly from the beginning of the design phase. We will also review the specifications available in most A/D Converter data sheets and identify the important specifications for driving your SAR. From this discussion, techniques will be explored which can be used to successfully drive the input of the SAR A/D Converter. Since most SAR applications require an active driving device at the converter's input, the final subject will be to explore the impact of an operational amplifier on the analog-to-digital conversion in terms of DC as well as AC responses.

AN693: *Understanding A/D Converter Performance Specifications*

The purpose of this application note is to describe the specifications used to quantify the performance of A/D converters and give the reader a better understanding of the significance of those specifications in an application. Although the information presented here is applicable to all A/D converters, specific attention is given to features of the standalone and PIC® microcontrollers with A/D converters.

AN793: *Power Management in Portable Applications: Understanding the Buck Switchmode Power Converter*

Powering today's portable world poses many challenges for system designers. The use of batteries as a prime power source is on the rise. As a result, a burden has been placed on the system designer to create sophisticated systems utilizing the batteries full potential.

Each application is unique, but one common theme rings through: **maximize battery capacity usage**. This theme directly relates to how efficiently the energy from the batteries is converted and transferred to the system load. No single method is ideal for all applications. Linear regulators, switched capacitor charge pumps and inductor based switchmode power converters are all employed. Each method has its associated advantages and disadvantages. It is the particular application with its individual requirements that determines which method will be the best to use.

AN947: *Power Management in Portable Applications: Charging Lithium-Ion/Lithium-Polymer Batteries*

This application note focuses on the fundamentals of charging Lithium-Ion/Lithium-Polymer batteries. In particular, a linear, stand-alone solution utilizing Microchip's MCP73841 will be explored.

AN948: *Efficiently Powering Nine White LEDs with the MCP1650*

The number of applications that utilize white LEDs has steadily increased due to the increased usage of Liquid Crystal Displays (LCDs) in automotive and cellular telephone displays, PDAs, handheld electronic games and computer monitors. In order to view the information on these displays, a light source is needed. Typically, this light source has been provided by Cold Cathode Fluorescent Tubes (CCFT). However, since designers are tasked with improving efficiency, lowering cost and decreasing size, white LEDs are now being used. Powering white LEDs, which have a forward drop (VF) of 3.6V, typically, becomes more difficult when the application requires multiple LEDs. In this Application Note, a solution using the MCP1650 is discussed and shown to be greater than 85% efficient.

AN960: *New Components and Design Methods Bring Intelligence to Battery Charger Applications*

This application note will describe a typical intelligent battery charger power system application. As with most real life applications, there are many demands made on the power system designer to protect the system in the case of battery removal, plugging the battery in backwards, reverse polarity at the input, a battery shorting and even more unimaginable situations. A complete battery charger, fuel gauge system design will be presented as an example of the mixed signal design method. Battery reference material and basic switchmode power supply converter trade-offs are covered in the beginning of this application note.

AN968: *Simple Synchronous Buck Regulator – MCP1612*

This application note contains all of the information needed to design a synchronous buck converter using the MCP1612. It also contains a real-world design example with measured laboratory data.

AN971: *USB Port-Powered Li-Ion/Li-Polymer Battery Charging*

The Universal Serial Bus, USB, allows many computer peripherals to be easily swapped for another without having to turn off the computer. Today, a variety of handheld, battery-operated peripherals provide USB ports to facilitate data transfer to and from a host computer. With the introduction of the new USB 2.0 specification, CD/DVD players, MP3 players, cameras, personal data assistants and even cell phones can transfer data at rates up to 480 Mbps. These peripherals are, in some instances, self-powered. As a result, many of these peripherals do not take full advantage of the USB port. Often overshadowed by the data interface of the USB port, a power port is provided. Microchip's MCP73853/55 and MCP73861 advanced, fully integrated, single cell Li-Ion charge management devices allow these peripherals to utilize the full "power" of the USB port.

AN1088: *Selecting the Right Battery System for Cost-Sensitive Portable Applications While Maintaining Excellent Quality*

Portable electronic devices have played an important role in a person's daily digital life and have changed the way people live and work. Commonly seen portable electronic devices are: cellular phones, media players, digital cameras, digital camcorders, handheld GPS, digital readers and PDAs. With the emerging technologies that are available today, portable electronic designers are trying to integrate more features into thinner and smaller form-factors while maximizing the battery life.

Microchip offers a number of boards to help evaluate device families. Contact your local Microchip sales office for a demonstration.

Evaluation Boards

MCP1252DM-BKLT: [MCP1252 Charge Pump Backlight Demonstration Board](#)

The MCP1252 Charge Pump Backlight LED Demo Board demonstrates the use of a Charge Pump device in an LED application. The board also serves as a platform to evaluate the MCP1252 device in general. The MCP1252-ADJ is an excellent choice for biasing the backlighting or driving other LED applications. Light intensity is controlled uniformly through the use of ballast resistors. The peak intensity is set by the feedback to the MCP1252-ADJ. Dimming is accomplished by pulse width modulating the shutdown pin of the device.

The board also features a PIC10F206 microcontroller in a SOT-23 package, which is used to provide an enable signal to the MCP1252. The PIC microcontroller also accepts a push-button input that allows the user to adjust the white LEDs to five different light intensities, in addition to placing the system in a standby mode that consumes less than 1 μ A of current (typical).

MCP1252EV: [MCP1252/53 Evaluation Kit](#)

The MCP1252/3 Evaluation Board is an evaluation kit designed to support Microchip's MCP1252-33X50, MCP1252-ADJ, MCP1253-33X50 and MCP1253-ADJ low noise, positive-regulated charge pump devices. The evaluation kit is fully assembled and tested. The kit is useful for evaluating simple stand-alone operation or for evaluating applications interfaced with a microcontroller.

MCP1256/7/8/9EV: [MCP1256/7/8/9 Charge Pump Evaluation Board](#)

The MCP1256/7/8/9 Charge Pump Evaluation Board is an evaluation and demonstration tool for Microchip Technology's MCP1256/7/8/9 Regulated 3.3V, Low-Ripple Charge Pumps with Low Operating Current Sleep mode or Bypass mode. The design provides for dynamic versatility. The MCP1256/7/8/9 Charge Pump Evaluation Board is setup to evaluate simple, stand-alone, DC-to-DC conversion. Two evaluation circuits are provided, demonstrating the versatility of the MCP1256/7/8/9 device family. One evaluation circuit utilizes the MCP1256, demonstrating the Sleep mode feature along with a power good indication. The other evaluation circuit utilizes the MCP1259, demonstrating the unique Bypass mode feature along with a low battery indication. When connected, the MCP1256/7/8/9 devices can be evaluated in a variety of applications.

MCP1601EV: [MCP1601 Buck Regulator Evaluation Board](#)

The MCP1601 Buck Regulator Evaluation Board demonstrates Microchip's MCP1601 Synchronous Buck Regulator, developed for battery powered applications as well as distributed power applications. The MCP1601 Evaluation Board is capable of operation over the entire 2.7V to 5.5V input range of the MCP1601 device. Two 2-position DIP switches are used, one to select the output voltage (1.8V, 2.05V, 2.45V or 3.28V) and one that turns the MCP1601 on and off with the other position selecting the mode of operation (PWM-pulse width modulation or PFM-pulse frequency modulation). Surface mount test points are used to apply power and load in addition to probing several points in the test circuit.

MCP1612EV: [MCP1612 Synchronous Buck Regulator Evaluation Board](#)

The MCP1612 Synchronous Buck Regulator Evaluation Board features Microchip Technology's 1A 1.4 MHz synchronous buck regulator in two buck converter applications. The first application uses the MCP1612 in an 8-lead MSOP package. This converter has four (0.8V, 1.0V, 1.2V and 1.4V) selectable output voltages available. The second application features the MCP1612 in an 8-pin DFN package. This converter also has four (0.8V, 1.7V, 2.4V and 3.3V) selectable output voltages. A shutdown terminal is also provided for each converter.

MCP1650EV: [MCP1650 Boost Controller Evaluation Board](#)

The MCP1650 Boost Controller Evaluation Board demonstrates Microchip Technology's MCP165X Boost Controller product family in two high-power, boost-converter applications. The first application features the MCP1651 (8-pin MSOP) with the low battery detect feature and provides a regulated 5V output with an input voltage range of 2.8V to 4.8V. The second application uses the MCP1653 (10-pin MSOP), with both low battery detect and power good features. The input voltage for this application is 3.3V, with the output boosted to 12V.

MCP1630DM-DBBK1: [MCP1630 1A Bias Supply Demo Board](#)

The MCP1630 1A Bias Supply Demo Board is used to evaluate Microchip's MCP1630 used in a SEPIC power converter application. The MCP1630 1A Bias Supply Demo Board is capable of providing a regulated output from an input voltage of 9V. The regulated output voltage is selectable at 3.3V or 5V. The regulated output remains constant for an output load range of 0A to 1A. An LED indicates the presence of output voltage.

MCP1630DM-NMC1: [MCP1630 NiMH Battery Charger Demonstration Board](#)

The MCP1630 High Speed PWM is interfaced to the PIC16LF818 to develop a complete NiMH battery charger with fuel gauge capability. The MCP1630 is used to regulate the battery charge current and protect the SEPIC power train against an open circuit (removed battery) or a shorted battery. The high speed (12ns current sense to output) capability of the MCP1630 is used to switch the SEPIC converter at 1 MHz, minimizing external inductor and capacitor cost, while the PIC16LF818 performs the complex NiMH battery charger timing functions. Both the MCP1630 and PIC16LF818 protect the battery and circuit in the event of a fault.

MCP1630RD-DBBK3: [MCP1630V Bidirectional 4 Cell Li-Ion Charger Reference Design](#)

As high power portable applications continue to gain in popularity, more innovative techniques are needed to charge the batteries while also providing a low regulated voltage to the system's high end digital electronics. For example, laptop computers, portable test equipment, portable printers, etc., all require more power than a single or two cell Li-Ion battery pack can efficiently store. As a result, three or four series Li-Ion cell packs are used to store the necessary power for these high end applications. The result is a high DC voltage used to store the energy requiring a difficult high voltage to low voltage dc-dc conversion. The MCP1630V bi-directional 4 Cell Li-Ion Charger Reference Design can be used to evaluate a design that boosts a low source voltage to charge four Li-Ion series cells while providing energy to the system simultaneously. When the source is removed, the same power train used to charge the battery pack provides a low regulated voltage to operate the system.

RELATED SUPPORT MATERIAL

MCP1630RD-LIC1: [MCP1630 Li-Ion Multi Bay Battery Charger Reference Design](#)

The MCP1630 Multi-Bay Li-Ion Charger is used to evaluate Microchip's MCP1630 used in a SEPIC power converter application. The MCP1630 Multi-Bay Li-Ion Charger is capable of charging two single-cell, Li-Ion battery packs in parallel utilizing an input voltage of 10V to 30V (battery packs are not included). Multiple boards can be daisy-chained for additional charger bays. The MCP1630 Multi-Bay Li-Ion Charger is intended for use in pseudo-smart battery charger applications utilizing battery packs containing Microchip's PS700 Battery Monitor. Standard battery packs can be utilized as well. The MCP1630 Multi-Bay Li-Ion Charger provides a constant current – constant voltage charge with preconditioning, cell temperature monitoring and battery pack fault monitoring. Each charger bay provides a status and fault indication. The MCP1630 Multi-Bay Li-Ion Charger automatically detects the insertion or removal of a battery pack.

MCP1630RD-LIC2: [MCP1630 Low-Cost Li-Ion Battery Charger Reference Design](#)

The MCP1630 Low-Cost Li-Ion Battery Charger is used to evaluate Microchip's MCP1630 in a SEPIC power converter application. As provided, the MCP1630 Low-Cost Li-Ion Battery Charger is capable of charging a single-cell, Li-Ion battery pack from an input voltage of 6V to 18V. The MCP1630 Low-Cost Li-Ion Battery Charger provides a constant current, constant voltage charge with preconditioning, cell temperature monitoring and battery pack fault monitoring. Also, the charger provides a status or fault indication. The MCP1630 Low-Cost Li-Ion Battery Charger automatically detects the insertion or removal of a battery pack.

MCP1650DM-LED1: [MCP165X 3W White LED Demo Board](#)

The MCP165X 3W White LED Demo Board demonstrates Microchip's MCP165X Boost Controller product family in a battery powered white LED application. The MCP1651 (8-pin MSOP) with low battery detect is featured in a SEPIC converter topology with an input voltage range of 2.0V to 4.5V.

MCP7382XEV: [MCP7382X Li-Ion Battery Charger Evaluation Board](#)

The MCP7382X Li-Ion Battery Charger Evaluation Board features three circuits utilizing the MCP73826, MCP73827 and MCP73828 devices to demonstrate simple, stand-alone, linear charging of single cell Lithium-Ion/Lithium-Polymer battery packs (the battery packs are not included).

MCP73831EV: [MCP73831 Evaluation Kit](#)

Two evaluation boards are provided in the MCP73831 Evaluation Kit. The boards are set up to evaluate simple, stand-alone, linear charging of single cell Li-Ion/Li-Polymer battery packs (the battery packs are not included). Each board design provides constant current charging followed by constant voltage charging with automatic charge termination. In addition, the MCP73831-2AC board provides preconditioning of deeply depleted cells. Each board design provides evaluation of the MCP73831 in two package options: a SOT-23-5 and a 8-pin 2x3 DFN for higher power handling capability.

MCP73833EV: [MCP73833 Li-Ion Battery Charger Evaluation Board](#)

The MCP73833 Evaluation Board is an evaluation and demonstration tool for Microchip's MCP73833/4 Stand-Alone Linear Li-Ion/Li-Polymer Charge Management Controllers. Two independent circuits are provided (only one is populated) for charging single cell Li-Ion/Li-Polymer battery packs (the battery packs are not included). Each circuit design provides constant current charging followed by constant voltage charging algorithm with automatic charge termination and battery temperature monitoring. In addition, the installed MCP73833-FCI/MF provides preconditioning of deeply depleted cells and a safety timer.

MCP7384XEV: [MCP7384X Li-Ion Battery Charger Evaluation Board](#)

The MCP7384X Li-Ion Battery Charger Evaluation Board features three circuits utilizing the MCP73841, MCP73842 and MCP73843 devices to demonstrate simple, stand-alone, linear charging of single or dual cell Lithium-Ion/ Lithium-Polymer battery packs (the battery packs are not included).

MCP7386XEV: [MCP7386X Li-Ion Battery Charger Evaluation Board](#)

The MCP7386X Evaluation Board is set up to evaluate simple, stand-alone, linear charging of single/dual cell Lithium-Ion/Lithium-Polymer battery packs (the battery packs are not included). The board design provides constant current charging followed by constant voltage charging with automatic charge termination. As provided, the MCP7386X Evaluation Board is set for a fast charge current level of 1.1A for single cell applications. The MCP73861 is equipped with shutdown control, status indicator, fault indicator, safety timer, and continuous cell temperature monitor. For dual cell applications, the MCP73862 can be substituted for the MCP73861. Refer to the appropriate data sheets for details on the individual device features.

MCP73855EV: [MCP73855 Li-Ion Battery Charger Evaluation Board](#)

The MCP73855 Evaluation Board is set up to evaluate simple, stand-alone, linear charging of single cell Li-Ion/Li-Polymer battery packs (the battery packs are not included). The board design provides constant current charging followed by constant voltage charging with automatic charge termination. As provided, the MCP73855 Evaluation Board is set for a fast charge current level of 85 mA. The MCP73855 is equipped with shutdown control, status indicator, and safety timers. Refer to the data sheet for details on the device features.

Support

Microchip is committed to supporting its customers in developing products faster and more efficiently. We maintain a worldwide network of field applications engineers and technical support ready to provide product and system assistance. In addition, the following service areas are available at www.microchip.com:

- **Support** link provides a way to get questions answered fast: <http://support.microchip.com>
- **Sample** link offers evaluation samples of any Microchip device: <http://sample.microchip.com>
- **Forum** link provides access to knowledge base and peer help: <http://forum.microchip.com>
- **Buy** link provides locations of Microchip Sales Channel Partners: www.microchip.com/sales

Sales Office Listing

AMERICAS

Atlanta

Tel: 678-957-9614

Boston

Tel: 774-760-0087

Chicago

Tel: 630-285-0071

Cleveland

Tel: 216-447-0464

Dallas

Tel: 972-818-7423

Detroit

Tel: 248-538-2250

Kokomo

Tel: 765-864-8360

Los Angeles

Tel: 949-462-9523

Santa Clara

Tel: 408-961-6444

Toronto

Mississauga, Ontario

Tel: 905-673-0699

EUROPE

Austria - Wels

Tel: 43-7242-2244-39

Denmark - Copenhagen

Tel: 45-4450-2828

France - Paris

Tel: 33-1-69-53-63-20

Germany - Munich

Tel: 49-89-627-144-0

Italy - Milan

Tel: 39-0331-742611

Netherlands - Druunen

Tel: 31-416-690399

Spain - Madrid

Tel: 34-91-708-08-90

UK - Wokingham

Tel: 44-118-921-5869

Training

If additional training interests you, then Microchip can help. We continue to expand our technical training options, offering a growing list of courses and in-depth curriculum locally, as well as significant online resources – whenever you want to use them.

- Regional Training Centers: www.microchip.com/rtc
- MASTERS Conferences: www.microchip.com/masters
- Worldwide Seminars: www.microchip.com/seminars
- eLearning: www.microchip.com/webseminars
- Resources from our Distribution and Third Party Partners www.microchip.com/training

ASIA/PACIFIC

Australia - Sydney

Tel: 61-2-9868-6733

China - Beijing

Tel: 86-10-8528-2100

China - Chengdu

Tel: 86-28-8665-5511

China - Hong Kong SAR

Tel: 852-2401-1200

China - Nanjing

Tel: 86-25-8473-2460

China - Qingdao

Tel: 86-532-8502-7355

China - Shanghai

Tel: 86-21-5407-5533

China - Shenyang

Tel: 86-24-2334-2829

China - Shenzhen

Tel: 86-755-8203-2660

China - Wuhan

Tel: 86-27-5980-5300

China - Xiamen

Tel: 86-592-2388138

China - Xian

Tel: 86-29-8833-7252

China - Zhuhai

Tel: 86-756-3210040

ASIA/PACIFIC

India - Bangalore

Tel: 91-80-3090-4444

India - New Delhi

Tel: 91-11-4160-8631

India - Pune

Tel: 91-20-2566-1512

Japan - Yokohama

Tel: 81-45-471- 6166

Korea - Daegu

Tel: 82-53-744-4301

Korea - Seoul

Tel: 82-2-554-7200

Malaysia - Kuala Lumpur

Tel: 60-3-6201-9857

Malaysia - Penang

Tel: 60-4-227-8870

Philippines - Manila

Tel: 63-2-634-9065

Singapore

Tel: 65-6334-8870

Taiwan - Hsin Chu

Tel: 886-3-572-9526

Taiwan - Kaohsiung

Tel: 886-7-536-4818

Taiwan - Taipei

Tel: 886-2-2500-6610

Thailand - Bangkok

Tel: 66-2-694-1351

1/26/09

Microcontrollers • Digital Signal Controllers • Analog • Serial EEPROMs

Information subject to change. The Microchip name and logo, the Microchip logo and PIC are registered trademarks of Microchip Technology Incorporated in the U.S.A. and other countries. All other trademarks mentioned herein are property of their respective companies. © 2009, Microchip Technology Incorporated. All Rights Reserved. Printed in the U.S.A. 2/09 DS39610D



MICROCHIP
www.microchip.com

Microchip Technology Inc.
2355 W. Chandler Blvd.
Chandler, AZ 85224-6199