

Product Data

Wide Range Measuring Amplifiers — Types 2610 and 2636

USES:

- IEC651 Type 0 precision sound level meter with Brüel&Kjær $\frac{1}{2}$ -inch Condenser Microphones
- Versatile vibration meter with Brüel&Kjær piezoelectric accelerometers and other vibration transducers
- Wide-range, high-accuracy voltmeter. Max.Hold for capture and display of short duration signal levels
- Low-noise amplifier with calibrated gain, selectable from -30 to $+100$ dB, and built-in calibration source
- Frequency analyzer with Brüel&Kjær Band Pass Filters

COMMON FEATURES:

- Overall frequency range from 1Hz up to 200kHz
- Measuring ranges from $10\mu\text{V}$ to 30V FSD (300V with 10:1 input probe) selectable in 10dB steps
- Interchangeable meter scales for sound, vibration and voltage measurements etc.
- Automatic indication of measurement mode, range, gain, and input and output overload
- Direct, plus Mic. Preamp. Input with 0; 28 and 200V microphone polarization
- Wide-range analog AC and DC outputs for magnetic tape and graphic recording

FEATURES 2610:

- Accurate true RMS indication for AC signals with crest factors up to 10 (up to 20 below FSD)
- Selectable "Fast", "Slow" and "20s" RMS averaging
- Max.Hold mode for RMS and Peak measurements. Max.Peak indication with signals of $25\mu\text{s}$ or longer
- 22.4Hz high-pass and "A"-weighting networks

FEATURES 2636:

- Accurate true RMS and Impulse indications for AC signals with crest factors up to 10 (50 below FSD)
- Selectable "Fast", "Slow" and 0.1 to 30s RMS averaging. Auto-control via Band Pass Filter Type 1617
- Accurate +Peak, -Peak and Max.Peak indications with signals of $8\mu\text{s}$ or longer
- Max.Hold mode for RMS, Impulse and Peak measurements
- Log and Lin meter display and DC output modes
- Selectable 22.4Hz high-pass, 22.4kHz low-pass, plus "A"-, "B"-, "C"- and "D"-weighting networks
- IEC-625-1/IEEE-488 compatible digital interface bus for digital read-out and control
- Automatic self-test mode

Introduction

The Brüel & Kjær Measuring Amplifiers Types 2610 and 2636 are two easy to use, multi-purpose, calibrated amplifier-voltmeters, featuring extreme versatility, a wide measurement range and laboratory precision. They may be used alone, or as the basis around which numerous measurement and analysis set-ups may be built for comprehensive and detailed investigation of sound, vibration and voltage signals.

The two Measuring Amplifiers are essentially similar. However, Type 2636 has a variety of extra facilities including a digital interface bus which greatly expand its range of measurement applications and uses. Both Measuring Amplifiers feature



960411e



960412e

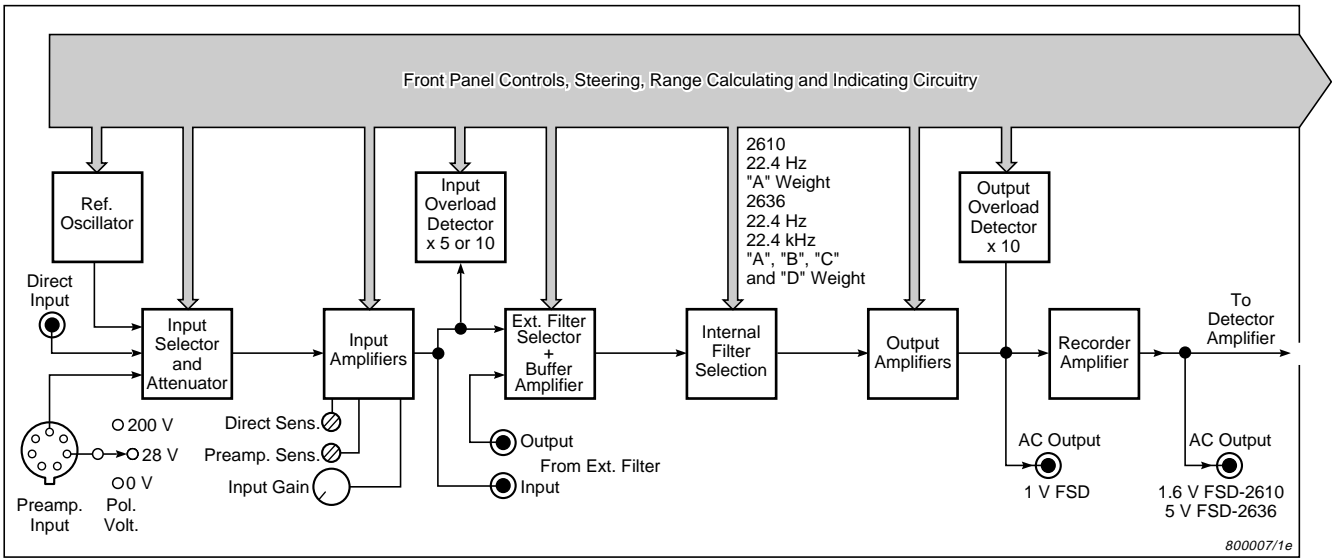

Fig.1 Input and Output AC Amplifier Sections of Measuring Amplifiers Types 2610 and 2636

interchangeable meter scales permitting direct reading of measured sound, vibration and voltage levels. They are also equipped with indicating lights which show the particular measurement mode, range and gain settings selected, as well as warn of input and output overload.

When used with one of a variety of Brüel & Kjær $\frac{1}{2}$ -inch Condenser Microphones and Preamplifiers available, Types 2610 and 2636 serve as a precision sound level meter meeting the strictest international and national standards for precision sound level measuring instrumentation. Type 2610 conforms with IEC 651 (Type 0), DIN 45633 (Part 1) and ANSIS14-1983 (Type 1), whilst, in

addition, Type 2636 conforms to "Impulse" sound measurement requirements of IEC and DIN.

Description

Operation and principle features of the 2610 and 2636 are discussed with reference to the simplified block diagram of the instruments shown in Figs.1 and 2.

Multi-purpose Inputs

Types 2610 and 2636 are furnished with two alternative AC coupled signal inputs — a Direct Input which accepts standard Brüel & Kjær coaxi-

al plugs and is used for voltage and vibration measurements etc., and a Preamp. Input which accepts the 7-pin plug of Brüel & Kjær Microphone Preamplifiers for sound measurements. Both inputs have a high input impedance of $1\text{ M}\Omega$ and can withstand voltage overloads as high as 220 V RMS (400 V Peak including DC component) without damage.

Besides serving as a signal input, the Preamp. Input supplies stabilized voltages for powering Microphone Preamplifiers. Furthermore it may be switched to provide +28 and +200V polarization necessary for operation of condenser microphones. A "0V" polarization setting is also available for pre-polarized types of microphone.

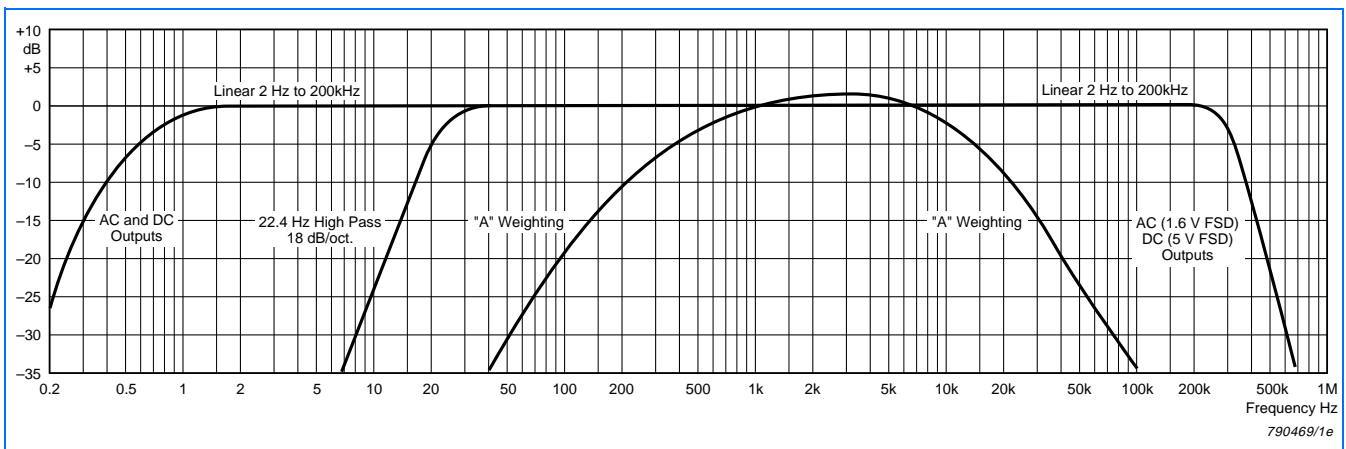

Fig.3 Typical overall frequency response of Measuring Amplifier Type 2610, with and without internal filter and weighting networks selected

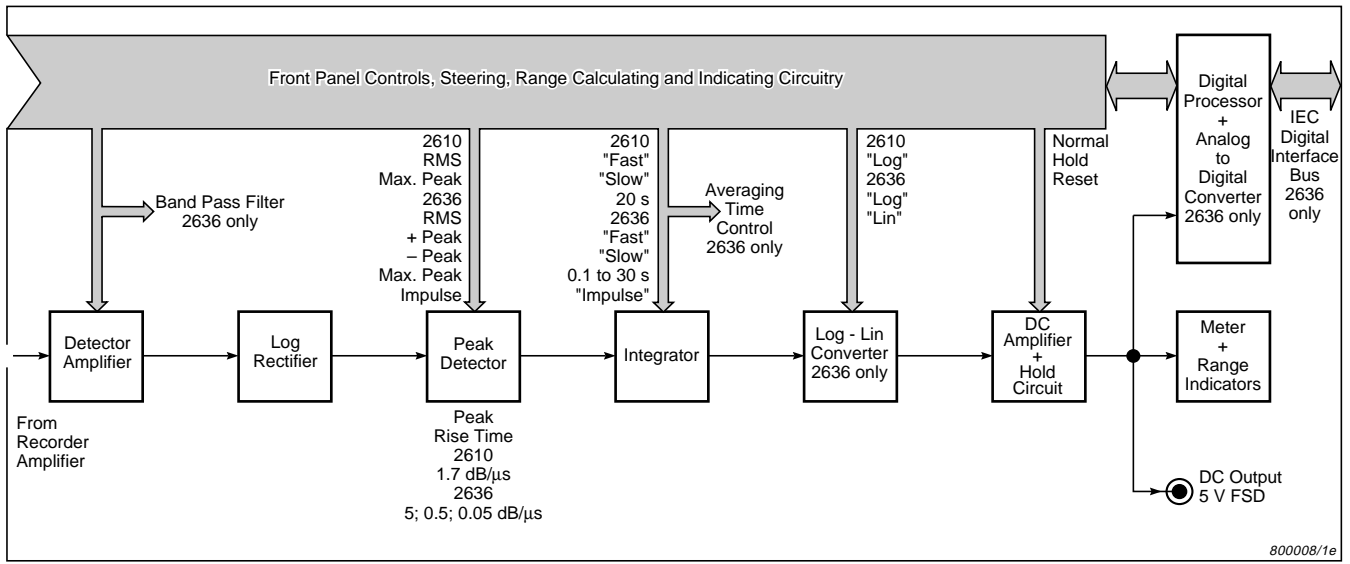

Fig 2 Rectifier and Meter Sections of Measuring Amplifier Type 2610, plus Digital Processing section of Measuring Amplifier Type 2636

To facilitate use of a wide range of measurement transducers of different sensitivity, the Direct and Preamp. Inputs are each equipped with their own individual, screwdriver accessible, sensitivity adjustment. These adjust the gain of the input section amplifier and together with a built-in 50mV, 1kHz sinusoidal reference source, enable the Measuring Amplifiers to be quickly and easily calibrated to give a direct meter reading for sound, vibration and voltage measurements, etc. Apart from eliminating the need of using an external reference for calibration, the internal reference voltage is ideal for calibrating magnetic tape and graphic re-

ording equipment which may be used with the Measuring Amplifiers.

Input and Output Amplifiers

The particular combination of cascaded amplifier and attenuator stages used with the input and output amplifier sections of the 2610 and 2636, gives them particularly good signal amplification linearity plus very low noise and distortion (see Common Specifications). Their nominal overall amplification and attenuation is from +100 to -30dB and may be switched in accurate 10dB steps to give voltage measurement ranges from 10μV to 30V for full scale meter deflection. Three rows of indicator lamps, two beside the Input and Output Section

Gain knobs and one at the bottom of the meter, automatically indicate which particular gain settings and measurements range have been selected.

As with most front panel control settings, the input and output section gain may be switched remotely. With the 2610 a remote switching arrangement may be connected via two multipin sockets inside the instrument, whilst with the 2636 switching may be conducted using a computer connected via the Digital Interface socket on the rear panel.

To facilitate measurement of very low signal levels, possibly in conjunction with external filters, an extra 0 to +10dB of continuous gain adjust-

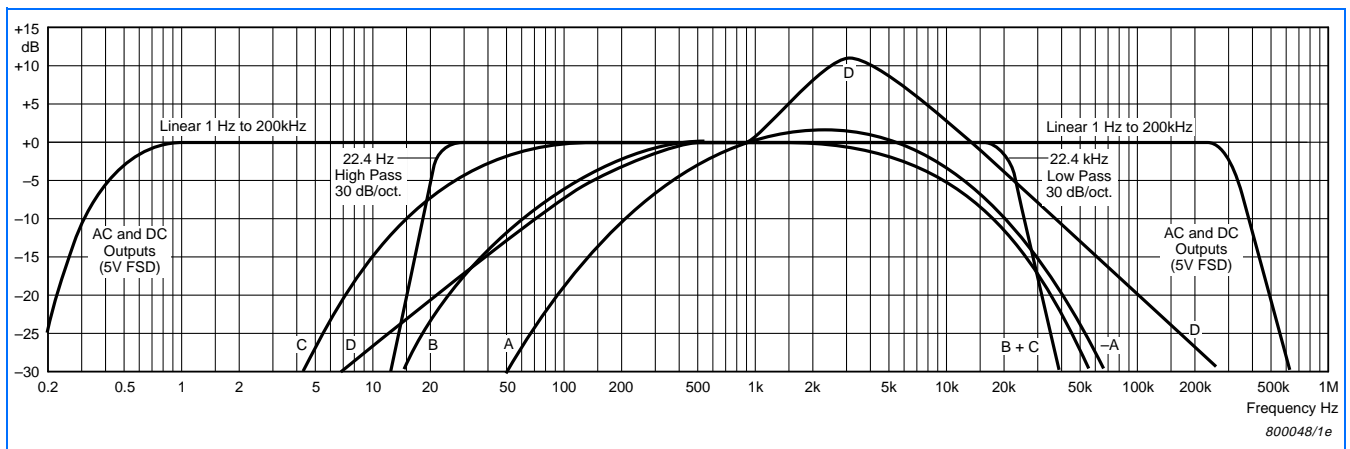

Fig 4 Typical overall frequency response of Measuring Amplifier Type 2636, with and without internal filter and weighting networks selected

ment is available via a separate knob. Alternatively for measurement of signals with voltage levels up to 300V RMS or Peak, extra attenuation may be obtained using a 10:1 Input Probe ZC0016 and BNC Adaptor JP0144 with the Direct Input of the Measuring Amplifiers. These are supplied as standard accessories with the 2636.

Overload Warning

For a reliable overload warning, the input and output amplifier sections have separate overload detectors. These are of particular help when using weighting networks or external filters with the Measuring Amplifiers, as overload by signals outside the filter pass band can sometimes produced a misleading meter indication, which without the benefit of overload detectors might not be interpreted as overload.

The two overload detectors respond to positive and negative going signals peaks as short as 200µs and when triggered cause the appropriate Input and (or) Output Section Gain lights to flash. The lights continue to flash for a minimum of 0.5 seconds, thus enabling very short duration overloads to be spotted.

To suit different maximum input voltage requirements, the input overload trigger level may be switched so that it is equivalent to 5 or 10 times the particular voltage range selected for measurements. These correspond to a maximum input voltage rating of 5 or 10V peak at the input of an external filter.

Filter Section

The overall frequency characteristics of the 2610 and 2636 are shown in Figs.3 and 4 respectively. Both Measuring Amplifiers are equipped with a 22.4Hz high-pass filter and an "A"-weighting network. In addition the 2636 includes a 22.4kHz low-pass filter plus "B"-, "C"- and "D"-weighting networks.

Whereas either one or both of the high- and low-pass filters may be selected, only one of the weighting networks may be used at any one time. The weighting networks are intended for sound measurements and comply with Type 0 requirements of IEC 651 for precision sound level meters. The high- and low-pass filters on the other hand, are useful for all types of measurement covering the audio frequency range and help reduce the influence of unwanted low and high

frequency environmental disturbances on measurements.

If required the Measuring Amplifiers may be connected with external filters for frequency analysis. These may be used with or without the internal filters and weighting networks selected and permit detailed investigation of the frequency composition of signals. See "Examples of Use".

Rectifier and Meter Section - 2610

The 2610 has a logarithmic meter response with true RMS and Max. Peak indicating modes. All commonly encountered signals can be measured including those with complex waveforms. A wide range Log. Rectifier with dynamic range of 70dB is used to perform the necessary signal rectification which with subsequent processing by a special integrator circuit provides a true RMS meter indication with overall accuracy of ± 0.5dB (± 0.2dB typical — see Fig.5). Signals with crest factors up to 10 can be handled at full scale, increasing to 20 for lesser deflections.

The integrator has selectable time constants enabling "Fast" and "Slow" time weighting characteristics in accordance with Type 0 requirements of IEC 651 for precision sound level meters to be selected. In addition a "20s" effective averaging time may be chosen which is beneficial for measurements and analyses using narrow band filters with the 2610.

For a peak indication, the Log rectified signal is applied to a separate Peak Detector, having a dynamic range of 60dB. This detects the maximum peak value (positive or negative, whichever is the greatest) of the input signal and has a typical rise and decay rate of 1.7dB/µs and 40dB/s respectively.

To facilitate measurement of very short duration transient signals and single events a "Hold" mode may be selected. This permits the maximum Peak or maximum RMS level of the signal to be captured and displayed on the meter. Using the Peak Hold mode for example, signals as short as 25 µs may be measured which have a peak excursion of 40 dB or less.

Rectifier and Meter Section - 2636

This is similar to that included in the 2610, but has a number of extra features, including a selectable Lin - Log response. For RMS measurements the same 70dB dynamic range and ± 0.5 dB overall (± 0.2dB typical) indication accuracy are available,

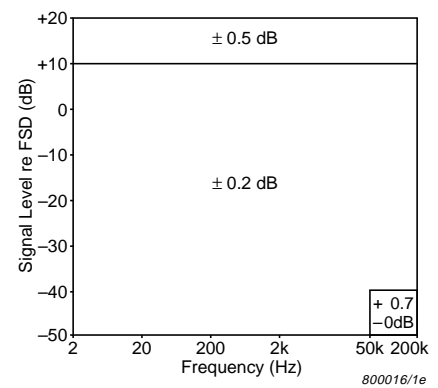

Fig.5 Typical measurement accuracy of the RMS Detector of the 2610 and 2636

plus a crest factor allowance of 10 at full scale. With reduced meter deflections, however, signals with crest factors of more than 50 can be handled, in contrast to 20 with the 2610.

In addition to "Fast" and "Slow" time weighting functions there is an "Impulse" mode. This includes a 35 ms time constant and is for measurement of the maximum RMS level of impulsive sounds in accordance with IEC 651. Also included for RMS measurements are a choice of time constants for precise averaging of signals when external filters are employed for frequency analysis. Six averaging time settings from 0.1 to 30s are available, which if required may be selected remotely via the Averaging Time or Digital Interface socket on the rear panel. This feature is of major benefit when using an Octave and Third Octave Band Pass Filter Type 1617 with the 2636, possibly together with a computer. See "Examples of Use".

For comprehensive measurement of peak levels, "+Peak", "-Peak" and "Max. Peak" indicating modes are available with the 2636. To accommo-

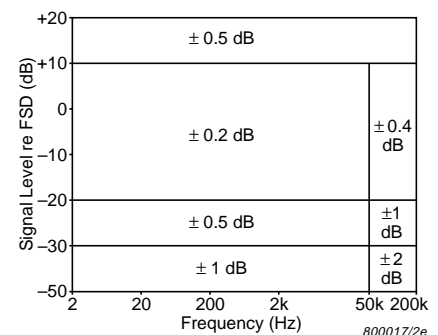

Fig.6 Typical measurement accuracy of the Peak Detector of the 2610 and 2636



Fig.7 Insertion of interchangeable meter scale for direct reading of measured sound, vibration and voltage levels

date for different types of signal, independent selection of 5; 0.5 and 0.05 dB/ μ s rise rates plus "Fast", "Slow" and "0.5s Hold" decay functions is possible, which if desired can be set to ignore unwanted high frequency noise spikes and overshoot components.

Like the 2610, the 2636 has a "Hold" mode whereby the maximum Peak, RMS or Impulse level of short duration signals and single events may be captured and displayed. In this case, however, signals as short as 8 μ s may be measured which have a peak excursion of 40 dB. For measurements over the full 60 dB dynamic range of the Peak Detector, signals as short as 12 μ s may be measured.

Indicating Meter

Both Measuring Amplifiers include a row of range indicating lights at the bottom of their meter and are supplied with interchangeable scales which are calibrated for direct reading of measured sound, vibration and voltage levels. With the 2610 the meter has a fixed 30dB Log display range, whilst with the 2636 separate settings for selection of Lin, 30dB Log and 60dB Log display ranges are available, which are indicated by lights at the top of the meter.

Besides the meter scales supplied, a variety of other interchangeable scales are available, including types for sound absorption and underwater sound measurements. Scales for sound measurement are furnished with a K-factor range whereby the Measuring Amplifiers may be calibrated for different microphone sen-

sitivities using their internal reference voltage. If required special scales can be made to order, or made using the Blank Scales SA 0082 (2610) and SA 0280 (2636) which are available. For a complete list of scales, ask for a "General Accessories" Product Data.

Analog Outputs

For feeding magnetic tape as well as level and X-Y recording equipment, there are two AC and one DC calibrated signal outputs from the Measuring Amplifiers. The AC Outputs provide an amplified (and if connected filtered) version of the input signal, whilst the DC Output produces a rectified, time-weighted, DC voltage proportional to the meter deflection on the Measuring Amplifiers. The maximum signal-to-noise ratio of the AC Outputs is 100dB. Similarly for RMS and Impulse measurements the maximum dynamic range of the DC Output is approximately 70dB, while for peak measurements it is 60dB.

Digital Interface - 2636

Supplementing the analog outputs of the 2636 is a Digital Interface bus. This conforms to IEC 625-1 for programmable measuring apparatus and is for output of measurement results transmitted by a 10-bit A/D Converter in the instrument. Results can be sent at 10ms intervals and are transmitted in printer or calculator format suitable for application to a computer or other digital equipment having an IEC 625-1 or IEEE-488 compatible interface.

Besides output of measurement results, information can be sent about which front panel control settings are selected. If required these settings may be controlled remotely via a computer, thus permitting fully automatic operation of the 2636. Control lights on the front panel of the Measuring Amplifier automatically show which control settings are chosen at any given instant.

Also shown by the control lights is the status of the IEC interface. These indicate whether the 2636 is under remote control, requests service (SRQ) or is a Listener or Talker. When in "Talk Only" the start and stop of a read-out can be controlled manually using the Read-Out switch of the instrument or may be controlled from an external clock in a computer or printer, for example.

In addition to a special program for automatic operation with the Brüel & Kjær Band Pass Filter Type 1617 (See "Examples of Use") including read-out of measurement results and filter centre frequency to a printer etc., a program is provided for automatic self-test of the 2636. This provides a basic check of most analog functions available with the front panel control switches and tests the attenuator and detector linearity, filter throughput and noise, as well as the detector time constants. If a fault is detected, then a warning is provided and a print out of the fault can be obtained. The total check out time is approximately 3 minutes.

Examples of Use

There are many applications of the Brüel & Kjær Measuring Amplifiers. They can be used alone for accurate spot measurements on voltage signals, including very short duration types with high crest factors and fast slew rates; or they can be used as amplifiers where a wide choice of calibrated gain settings and high signal-to-noise ratio are required. They may also be used for comprehensive measurement in acoustics, electroacoustics and in shock and vibration investigations etc., for which Brüel & Kjær produce an extensive range of accessory equipment including transducers.

For detailed investigation of sound, vibration and voltage signals, the 2610 and 2636 can be coupled with an external filter enabling discrete or swept frequency analysis to be performed. Suitable types of filter are shown in Fig.8. For AC or DC graphic recording of the analysis, a Brüel & Kjær Level or X-Y Recorder can be used, thereby enabling the analysis to be performed entirely automatically with synchronous switching or tuning of the filter centre frequency.

An important advantage of DC recording is that averaging of the signal is performed by precise electrical R-C time constants in the Measuring Amplifiers. This is of particular value when using the 2636 Measuring Amplifier with the 1617 Octave and Third Octave Band Pass Filter. With this instrument combination analyses can be performed entirely automatically with the 1617 stepping the Measuring Amplifier averaging time during the course of the analysis. For

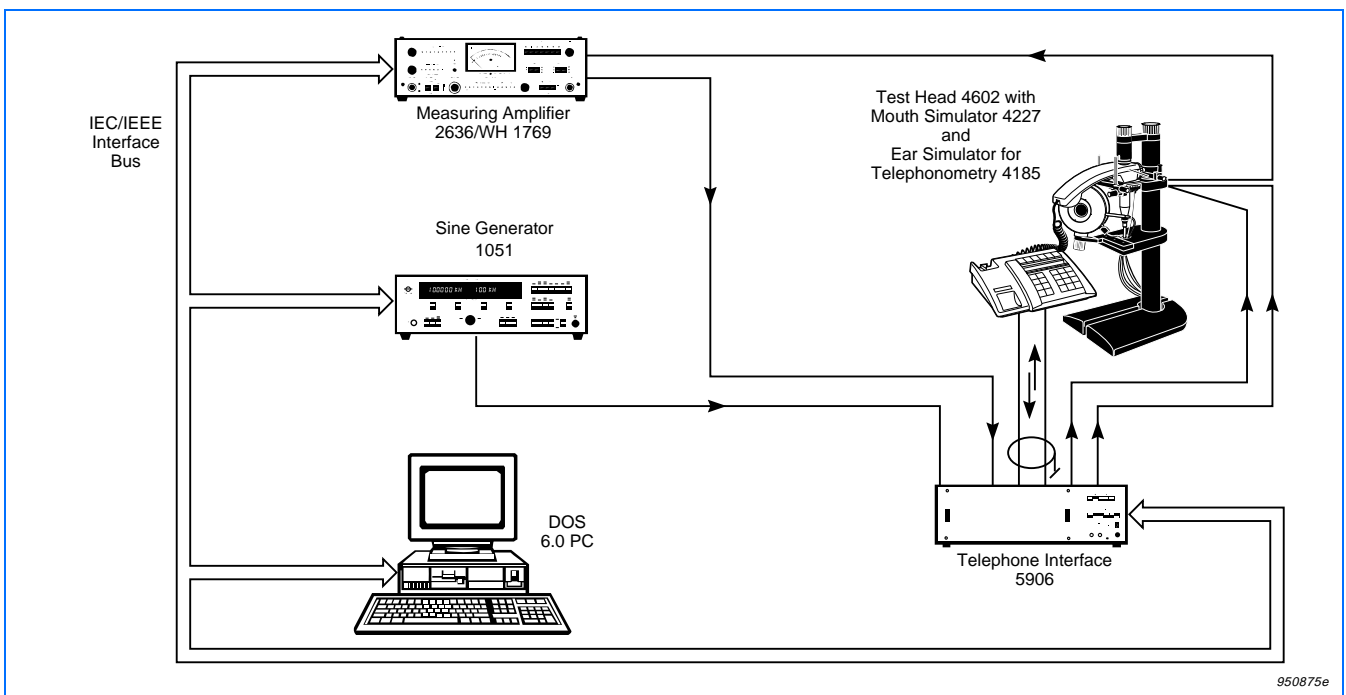

Fig.8 Configuration of Basic Telephone Test Bench Type 6702 controlled by a PC

this purpose the 1617 has a number of averaging time programs which select the appropriate averaging time. The appropriate averaging time is chosen on the basis of keeping the overall analysis time as short as possible, whilst maintaining a good overall confidence level for the analysis. This saves considerable time especially when low frequency signals have to be analysed.

Another way of processing and documenting results is by digital means. For this purpose the 2636 can be used to supply data in digital form to a computer and/or alphanumeric printer. Besides allowing large amounts of data to be quickly processed, a com-

puter can be used to control which particular measurement range, filter, detector, averaging time etc. is selected on the 2636, thus enabling a series of repetitive measurements, frequency analyses and production-line product checks to be performed entirely automatically.

The Type 2636 is also an integral part of the Basic Telephone Test Bench Type 6702 which is based on Electroacoustic Test Software Type 5302 (see Fig. 8).

The ETS software is a high-level applications program which controls measurements, performs post-processing, creates displays and stores results in a flexible environ-

ment. Pop-up menus simplify the creation of test Sequences. These systems are equally suited for both development and quality-control applications.

Typical measurement results include frequency response, sensitivity, Loudness Rating, distortion, impedance and polarity. A check against tolerance limits resulting in a pass/fail indication can also be performed.

The Basic Telephone Test Bench Type 6702 is particularly well suited for testing telephones and loudspeakers, as the software controls the necessary electrical and acoustical interfaces to these measurement objects.

Common Specifications 2610 and 2636

AMPLIFIER RESPONSE:

Measuring Ranges:

10 μ V to 30V FSD with LED indication of particular meter range selected. 100 μ V to 300V with 10:1 Attenuator Probe ZC0016 supplied with 2636

Frequency Range (without filters):

2Hz to 200kHz (± 0.5 dB) – 2610 only

1Hz to 200kHz (± 0.5 dB) – 2636 only

10Hz to 50kHz (± 0.2 dB) – 2610:2636

Phase Deviation (without filters):

$\pm 5^\circ$ between any two 2610's or 2636's in 20Hz up to 20kHz range

Gain (for 1V FSD Output):

From -30 to +100dB selectable in 10 ± 0.05 dB steps, plus extra 0 to 10dB of continuous gain adjustment between steps. LED indication of particular gain setting selected

DIRECT INPUT:

Via standard Brüel&Kjær coaxial socket

Impedance: 1M Ω || 70pF (2610) or 1M Ω || 90pF (2636)

Max. Input Voltage: 42V RMS in accordance with IEC 348, but can withstand up to 220V RMS (50 to 60Hz). 400V peak including DC component

PREAMP. INPUT:

Via standard Brüel&Kjær 7-pin microphone preamplifier socket. Supplies following

Microphone Polarization: 0; +28 and +200V from 20M Ω source

Preamplifier Voltage: +150V (2mA max.) 12k Ω source

Heater Voltage: +6V (at 200mA) from 30 Ω source or +12V (200mA max.) from 100m Ω source

INTERNAL REFERENCE:

Facilities calibration of 2610 and 2636 for sound, vibration and voltage measurements

Reference Signal: 50mV RMS (~ 94 dB re 1 μ V), 1kHz sine wave

Amplitude Stability: Better than 2% between +5 and 40°C (+41 and +104°F)

EXTERNAL FILTERS:

Provision for connecting external filters in series with internal filters and weighting networks via two BNC sockets on rear panel

To (Ext. Filter) Input: 1V RMS nominal, 10V peak max. output. Max. load 5k Ω || 200pF

From (Ext. Filter) Output: 1V RMS nominal, 10V peak max. input. Input impedance 1M Ω || 50pF

AC OUTPUTS:

From Output Section Amplifier via standard Brüel&Kjær coaxial socket on front panel

1V FSD Output: 10V peak max. with max. load of 10k Ω || 200pF

Output Impedance: $\sim 100\Omega$

From Recorder Amplifier via BNC socket on rear panel

1.6V FSD Output (2610 only): 16V peak max. with max. load of 10k Ω || 200pF

5V FSD Output (2636 only): 50V peak max. load of 10k Ω || 200pF

Output Impedance: $\sim 50\Omega$

OVERLOAD WARNING:

Gain indicators flash when Input and (or) Output Section is overloaded by positive or negative signal peaks of too high level

Input Overload Level: Equivalent to 5 or 10 times FSD on meter. Level selectable using switch on rear panel

Output Overload Level: Equivalent to 10 times FSD on meter

Min. Overload Duration: 200 μ s

Duration of Warning: 0.5s or longer

HARMONIC DISTORTION:

Input Section: <0.01% at 1kHz, <0.1% at 50kHz. Max. load 5k Ω || 200pF

Output Section: <0.1% at 1kHz. <0.3% at 50kHz. Max. load 10k Ω || 200pF

NOISE REFERRED TO INPUT:

Max. amplification with input shorted

Input Section Noise:

Lin 2 (or 22.4)Hz to 200kHz $\leq 5\mu$ V

Lin 2 (or 22.4)Hz to 22.4kHz $\leq 1.5\mu$ V

A-, B- and C-Weighting $\leq 1.5\mu$ V

D-Weighting $\leq 2.5\mu$ V

See EMC Immunity, Note 2

Output Section Noise:

Lin 2Hz to 200kHz typ. 50 μ V

SIGNAL-TO-NOISE RATIO:

Approximately 100dB in "100mV" reference position

INFLUENCE OF MAGNETIC FIELDS:

Input section with maximum gain and input short circuited typ. 10 μ V at 80A/m 50Hz

DETECTOR TEMP. STABILITY:

± 0.5 dB from +5 to +40°C

POWER REQUIREMENTS:

Supply Voltage: 100; 115; 127; 200; 220; 240V (50–60Hz) $\pm 10\%$ AC

Power Consumption:

~ 25 VA nominal (2610 only)

~ 35 VA nominal (2636 only)

CABINET:

Supplied as model A (light-weight metal cabinet) or model C (as A but with flanges for standard 19-inch rack)

DIMENSIONS:

Metal cabinet excluding knobs and feet

Height: 133mm (5.2in)

Width: 430mm (16.9in)

Depth: 200mm (7.9in)

WEIGHT:

2610: 5.2kg (11.5lb.)

2636: 6.5kg (14.3lb.)

COMPLIANCE WITH STANDARDS:

	CE-mark indicates compliance with: EMC Directive and Low Voltage Directive.
Safety	EN 61010–1 and IEC 1010–1: Safety requirements for electrical equipment for measurement, control and laboratory use.
EMC Emission	EN 50081–1: Generic emission standard. Part 1: Residential, commercial and light industry. CISPR 22: Radio disturbance characteristics of information technology equipment. Class B Limits. FCC Rules, Part 15: Complies with the limits for a Class B digital device.
EMC Immunity	EN 50082–1: Generic immunity standard. Part 1: Residential, commercial and light industry. Note 1: The above is guaranteed using accessories listed in this Product Data sheet only. Note 2: Susceptibility to radiated RF (3V/m, 80% AM): Input noise in all bandwidths up to 120 μ V (2610), 38 μ V (2636).
Temperature	IEC 68–2–1 & IEC 68–2–2: Environmental Testing. Cold and Dry Heat. Operating Temperature: 5 to 40°C (41 to 104°F) Storage Temperature: –25 to +70°C (–13 to 158°F)
Humidity	IEC 68–2–3: Damp Heat: 90% RH (non-condensing at 30°C (86°F))
Mechanical	Non-operating: IEC 68–2–6: Vibration: 0.3 mm, 20 m/s ² , 10–500 Hz IEC 68–2–27: Shock: 1000 m/s ² IEC 68–2–29: Bump: 1000 bumps at 250 m/s ²
Enclosure	IEC 529 (1989): Protection provided by enclosures: IP 20

Additional Specifications 2610

FILTER MODES:

22.4Hz: High-pass filter with low frequency attenuation slope of 18dB/octave (60dB/decade)

A-Weighting: In accordance with IEC 651 (Type 0) for precision sound level meters

Ext.: See Common Specifications

METER INDICATION:

Moving coil meter with interchangeable meter scales and LED indication of particular measurement range selected

Measurement Range: 10 μ V to 30V FSD selectable in accurate 10 \pm 0.05dB steps

Indication Ranges: 0 to 10 and 1 to 30 logarithmically graduated amplitude ranges, plus 0 to 30dB linearly graduated range

DETECTOR CHARACTERISTICS:

For Meter and DC Output

RMS Mode:

Crest Factor Capability: 10 at full scale. 20 for lesser deflections

Dynamic Range: +20 to -50dB re FSD

Accuracy: \pm 0.2dB typ. \pm >0.5dB overall

Averaging: "Fast" and "Slow" in accordance with IEC 651 (Type 0), plus 20s effective averaging time

Max. (Positive or Negative) Peak Mode:

Dynamic Range: +20 to -40dB re FSD

Accuracy: \pm 0.2dB typ. See Fig.6

Rise Rate: 1.7dB/ μ s corresponding to rise time of \sim 25 μ s for 40dB change in signal level

Decay Rate: 40dB/s

Max. Hold Mode: Meter and DC Output hold max. RMS or max. Peak level of signal. Hold decay <0.2dB/minute at 25°C

Reset Mode: Meter and DC Output reset to zero with 0.3s delay before meter indication and DC output voltage restored

DC OUTPUT:

From Detector Amplifier via BNC socket on rear panel

Output Voltage: 100mV/dB; 5V DC re FSD; 7V (10mA) max.

Output Impedance: \sim 50 Ω

Dynamic Range: See Detector Characteristics

Additional Specifications 2636

FILTER MODES:

22.4Hz: High-pass filter with low frequency attenuation slope of more than 30dB/octave (100dB/decade)

22.4kHz: Low-pass filter with high frequency attenuation slope more than 30dB/octave (100dB/decade)

A-, B-, C- and D-Weighting: In accordance with IEC 651 (Type 0) for precision sound level meters

Ext.: See Common Specifications

METER INDICATION:

Moving coil meter with interchangeable scales and LED indication of measurement and scale range selected

Measurement Ranges: 10 μ V to 30V FSD selectable in accurate 10 \pm 0.05dB steps. 100 μ V to 300V FSD with 10:1 Attenuation Probe ZC0016 supplied

Lin. Mode Indicating Ranges: 0 to 10 and 0 to 31.6 Linearly graduated amplitude ranges, plus $-\infty$ to +20dB range

30dB Log. Mode Indicating Ranges: 0 to 10 and 1 to 30 Logarithmically graduated amplitude ranges, plus 0 to 30dB Linearly graduated range

60dB Log. Mode Indicating Ranges: 0.3 to 300 and 1 to 1000 Logarithmically graduated amplitude range, plus 0 to 60dB Linearly graduated range

DETECTOR CHARACTERISTICS:

For Meter and DC output

RMS Mode:

In accordance with IEC 651 Type 0 except for meter overswing with the Log-60dB indicating mode

Crest Factor Capability: 10 at full scale; Up to 50 for lesser deflections

Dynamic Range: +20 to -50dB re FSD

Accuracy: \pm 0.2dB typ. \pm 0.5dB overall

Averaging: "Fast" and "Slow" to IEC 651 (Type 0), plus 0.1; 0.3; 1; 3; 10 and 30s averaging times

Positive, Negative and Max. Peak Modes:

Dynamic Range: +20 to -40dB re FSD

Accuracy: \pm 0.2dB typ. See Fig.6

Rise Rate: 5; 0.5 and 0.05dB/ μ s corresponding to rise time of 8, 80 and 800 μ s for 40dB change in signal level

Decay Rate: "Fast" (43.4dB/s); "Slow" (4.34dB/s) and 0.5s Max. Hold

Impulse Mode: In accordance with IEC 651 (Type 0 impulse) for precision sound level meters

Max. Hold Mode: Meter and DC Output hold Max. RMS, Impulse and Peak Level of signal. Hold decay <0.2dB/minute at 25°C

Reset Mode: Meter and DC Output reset to zero with \sim 0.3s delay before meter indication and DC output voltage restored

DC OUTPUT:

From Detector Amplifier via BNC socket on rear panel

Log. Mode Output: 100mV/dB; 5V DC re FSD; 7V (10mA) max.

Lin. Mode Output: 5V DC re FSD; 12V (10mA) max.

DIGITAL SECTION:

Accuracy: \pm 0.1dB (Log) at 25°C

\pm 0.3% (Lin) of FSD

Gain Error: \pm 0.2dB at FSD at 5 to 40°C

Conversion Time: 10ms \pm 0.1%

IEC DIGITAL INTERFACE:

Conforms to IEC 625-1, compatible with IEEE Std. 488 interface

IEC Functions Implemented: Source Handshake (SH1), Acceptor Handshake (AH1), Talker (T5), Talk Only, Listener (L4), Remote Local (RL1), Service Request (SR1)

Data: Format for calculator or printer may be selected. Data transmitted via A/D converter every 10ms

Code: ISO 7-bit code (i.e. ASCII, but without parity bit)

Remote Control: Front panel settings selectable via standard interface

Special functions included:

1617-2636 Control: Program for automatic operation with 1617 Band Pass Filter and averaging time selection with 2636, plus read-out of frequency and measurement results to printer

Self Test: Program for automatic self-test and basic check out of 2636. Checks front panel switch functions, attenuator and detector linearity, detector time constants, filter attenuation and noise. Check out time approximately 3 minutes

Ordering Information 2610

Type 2610: Measuring Amplifier
Includes the following Accessories:
JP 0144: B&K to BNC coaxial adaptor
SA 0250: ms^{-2} Scale (30 dB Log)
SA 0252: dB SPL Scale (28 – 89 mV/Pa. 30 dB Log)
SA 0253: dB SPL Scale (5 – 16 mV/Pa. 30 dB Log)

See General Accessories Product Data for other scales available
2 × VF 0030: 125 mA slow blow fuse
3 × VF 0031: 250 mA slow blow fuse
2 × VS 1273: Scale lamps, 7 V/250 mA
Power cable

Accessories Available:

DB 2609: Preamp. Input Adaptor for old Brüel & Kjær 7-pin plugs
ZG 0350: 7-pin LEMO to B & K Adaptor

Ordering Information 2636

Type 2636: Measuring Amplifier
Includes the following Accessories:
JP 0144: B&K to BNC coaxial adaptor
JP 0802: 8-pin DIN plug
SA 0259: Volts, dB Scale (Lin)
SA 0261: Volts, dB Scale (60 dB Log)
SA 0262: dB SPL Scale (28 – 89 mV/Pa. 30 dB Log)
SA 0263: dB SPL Scale (5 – 16 mV/Pa. 30 dB Log)
SA 0267: dB re $1\mu\text{V}$ Universal Scale (Lin; 30 and 60 dB Log)
SA 0270: ms^{-2} Universal Scale (30 dB Log)
See General Accessories Product Data for other scales available
UA 0793: IEC 625-1 25-way Bus
3 × VF 0042: 315 mA slow blow fuse
2 × VF 0051: 160 mA slow blow fuse
2 × VS 1273: Scale lamps, 7 V/250 mA
ZC 0016: 10:1 Attenuator Probe
Power Cable

Accessories Available:

DB 2609: Preamp. Input Adaptor for old Brüel & Kjær 7-pin plugs
ZG 0350: 7-pin LEMO to B & K Adaptor
AQ 0034: 1617 Filter Control Cable
AO 0145: Averaging Time Control Cable
AO 0194: Interface Cable (2 m), IEC 625-1 (25-way)
AO 0184: Interface Cable (2 m), IEC (25-way male, slide lock) to IEC 625-1
AO 0264: Interface Cable (2 m), IEC 625-1 (25-way) to IEEE-488
AO 0195: Adaptor to convert IEEE-488 connector to IEC 625-1 (25-way)

Modifications Available

WH 1769: 10 s and 30 s RMS averaging changed to 10 ms and 30 ms, respectively. This modification is used in Basic Telephone Test Bench Type 6702
WH 1698: "D" weighting network replaced by a standardised Psophometric filter (CCITT Rec.P.53)
WH 2632: "D" weighting network replaced by a standardised C-Message filter (IEEE 743)

These modifications are not standard production instruments. Specifications can be modified, on a contract basis, to meet individual requirements. For prices and delivery time, please contact your local Brüel & Kjær representative

Brüel & Kjær reserves the right to change specifications and accessories without notice



WORLD HEADQUARTERS:

DK-2850 Naerum · Denmark · Telephone: +45 45 80 05 00 · Fax: +45 45 80 14 05 · Internet: <http://www.bk.dk> · e-mail: info@bk.dk

Australia (02) 9450-2066 · Austria 00 43-1-865 74 00 · Belgium 016/44 92 25 · Brazil (011) 246-8166 · Canada: (514) 695-8225 · China 10 6841 9625 / 10 6843 7426

Czech Republic 02-67 021100 · Finland 90-229 3021 · France (01) 69 90 69 00 · Germany 0610 3/908-5 · Holland (0)30 6039994 · Hong Kong 254 8 7486

Hungary (1) 215 83 05 · Italy (02) 57 60 4141 · Japan 03-3779-8671 · Republic of Korea (02) 3473-0605 · Norway 66 90 4410 · Poland (0-22) 40 93 92 · Portugal (1) 47114 53

Singapore (65) 275-8816 · Slovak Republic 07-37 6181 · Spain (91) 36810 00 · Sweden (08) 71127 30 · Switzerland 01/94 0 09 09 · Taiwan (02) 713 9303

United Kingdom and Ireland (0181) 954-236 6 · USA 1 - 800 - 332 - 2040

Local representatives and service organisations worldwide