

MAIN PCB CHASSIS SCHEMATIC DIAGRAM

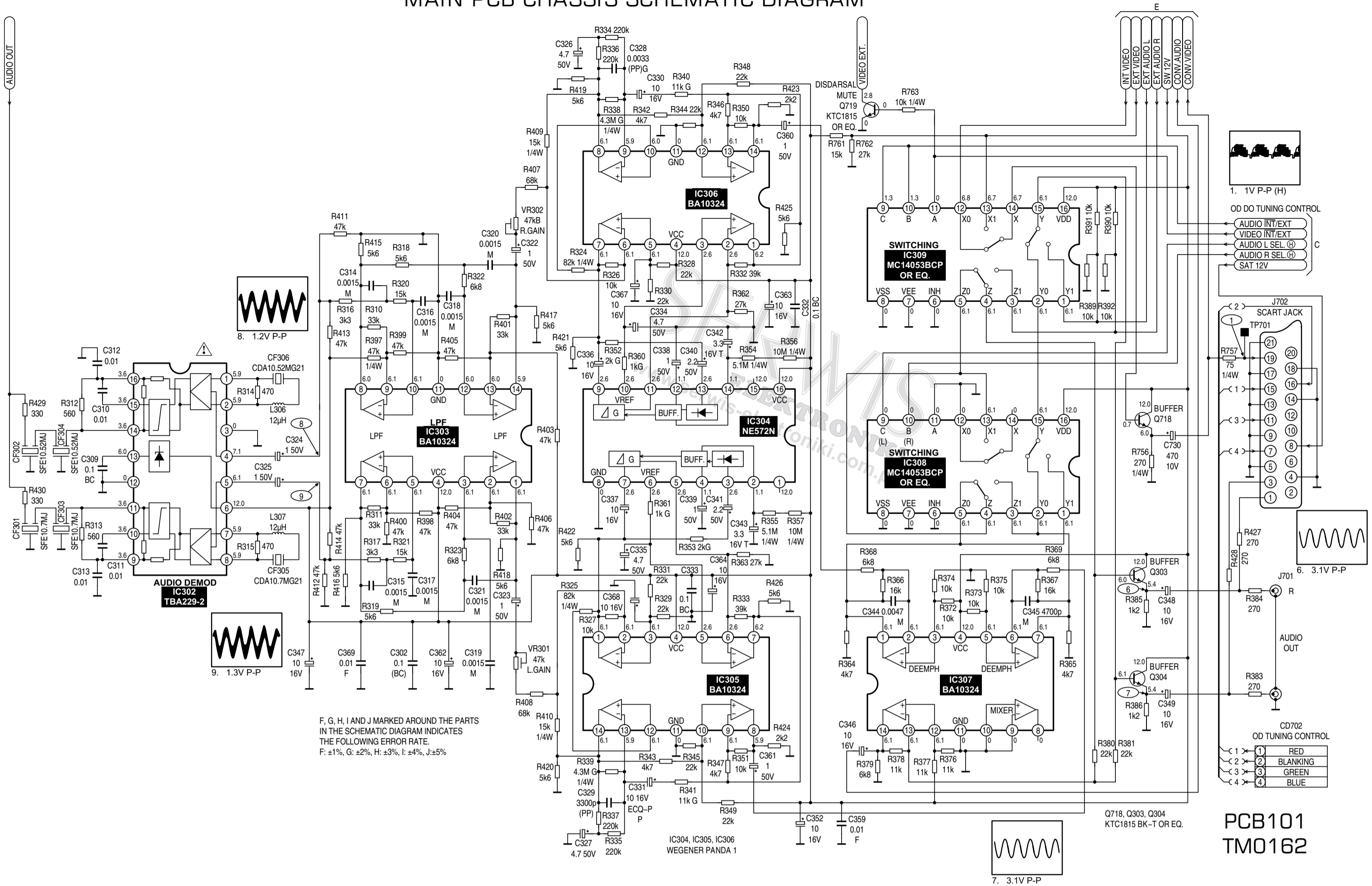

DISPLAY/CONTROL CHASSIS SCHEMATIC DIAGRAM

