

COMPUTER-CONTROLLED TELETXT DECODER

- AUTOMATIC SELECTION OF UP TO SEVEN NATIONAL LANGUAGES
- FOUR SIMULTANEOUS PAGE REQUESTS
- DISPLAY OF THE 25TH STATUS ROW
- MICROPROCESSOR CONTROL VIA AN I²C BUS (SLAVE ADDRESS 0010001 R/W)
- DATA ACQUISITION AVAILABLE FROM LINES 2 TO 22 OR FROM A COMPLETE FIELD.
- DIRECT INTERFACE TO A STATIC RAM OF UP TO 8kBYTES
- HIGH QUALITY DISPLAY USING A CHARACTER MATRIX OF 12 x 10 DOTS.
- SINGLE + 5V SUPPLY VOLTAGE
- ON-CHIP MASK PROGRAMMABLE ROM CHARACTER GENERATORS
- NMOSH2 PROCESS

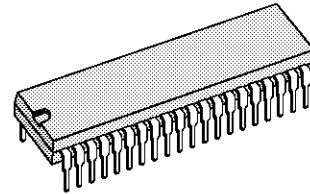

DIP40
(Plastic Package)

ORDER CODES :
SDA5243 - West European Languages
SDA5243/H - East European Languages

DESCRIPTION

The SDA5243 is a NMOSH2 integrated circuit which performs all the processing of logical data within a 625 line system teletext decoder. It is designed to operate in conjunction with at least two chips : the SAA5231 integrated chip which extracts Teletext information embedded in a composite video signal and up to eight kilobytes of static RAM memory which can be used to store a maximum of 8 pages of display data. A complete system also comprises a microprocessor controlling the SDA5243 via a 2-wire serial bus. An on-chip ROM memory contains the character sets. The SDA5243 performs automatic selection of one of up to seven natural languages. Data bytes may be decoded in either 7-Bit plus parity or in full 8-Bit formats. The chip set also supports facilities for reception and display of higher-level protocol data.

PIN CONNECTIONS

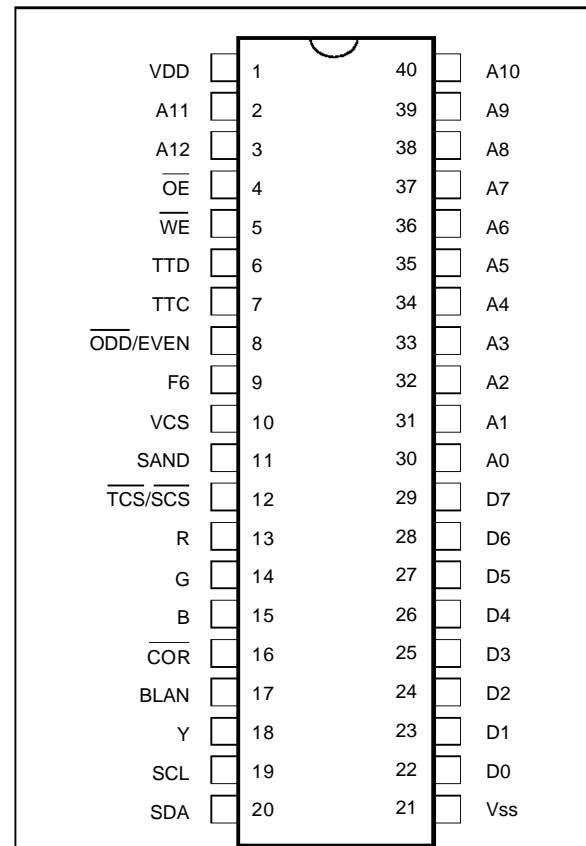

5243-01.EPS

PIN DESCRIPTION

Pin	Symbol	Function	Description
1	V _{DD}	+5V	Positive supply voltage
2, 3, 40	A11, A12, A10	Chapter address	Address selection outputs for 1 of 8 static RAM chapters each of 1 kBytes.
4	\overline{OE}	Output enable	Active-low RAM output enable control signal.
5	\overline{WE}	Write enable	Active-low RAM write enable control signal. It supports write-cycles interleaved with read-cycles.
6	TTD	Teletext data input	An A.C. coupled teletext data input supplied by the SAA5231 chip is latched to V _{SS} between 4 and 8μs after each TV line.
7	TTC	Teletext clock input	A 6.9375MHz clock signal, supplied by the SAA5231 chip, is internally A.C. coupled, clamped and buffered.
8	$\overline{ODD/EVEN}$	Interlaced mode state output	High for even numbered and low for odd-numbered frames. The value is valid 2μs before the end of lines 311 and 624.
9	F6	Character display clock signal	The 6MHz clock signal, supplied by the SAA5231 chip is internally A.C. coupled, clamped and buffered.
10	VCS	Video composite synchronization input signal	Active high VCS input.
11	SAND	Sandcastle	Three level output pulse to the SAA5231 device. Phase lock, blanking signal, and color burst components are contained in this signal.
12	$\overline{TCS/SCS}$	Input / output composite synchronization signal	Scan composite input signal (\overline{SCS}) for the display synchronization or Text composite sync. (TCS) output signal to the SAA5231. Both signals are active low.
13, 14, 15	R G B	Red, green, blue	Character and background colors active-high open-drain outputs.
16	\overline{COR}	Contrast reduction	Open-drain active-low output supporting optimal display of characters in "mixed mode" operation.
17	BLAN	Blanking signal output	Open-drain active high output for TV-image blanking in normal and mixed-mode operation.
18	Y	Foreground output	Open-drain active-high output with foreground information. Can be used for printer command.
19	SCL	Serial clock	Microprocessor clock input via serial bus.
20	SDA	Serial data input / output	Open-drain microprocessor serial data input/output via serial bus.
21	V _{SS}	0 Volt	Ground.
22-29	D0-D7	Parallel data input / output	Eight tri-state input/output for data read/write from/to an external RAM.
30-39	A0-A9	Address signals	Ten addresses output pins for accessing to individual Bytes of a 1 kByte chapter stored in an external Static RAM.

5243-01.TBL

BLOCK DIAGRAM

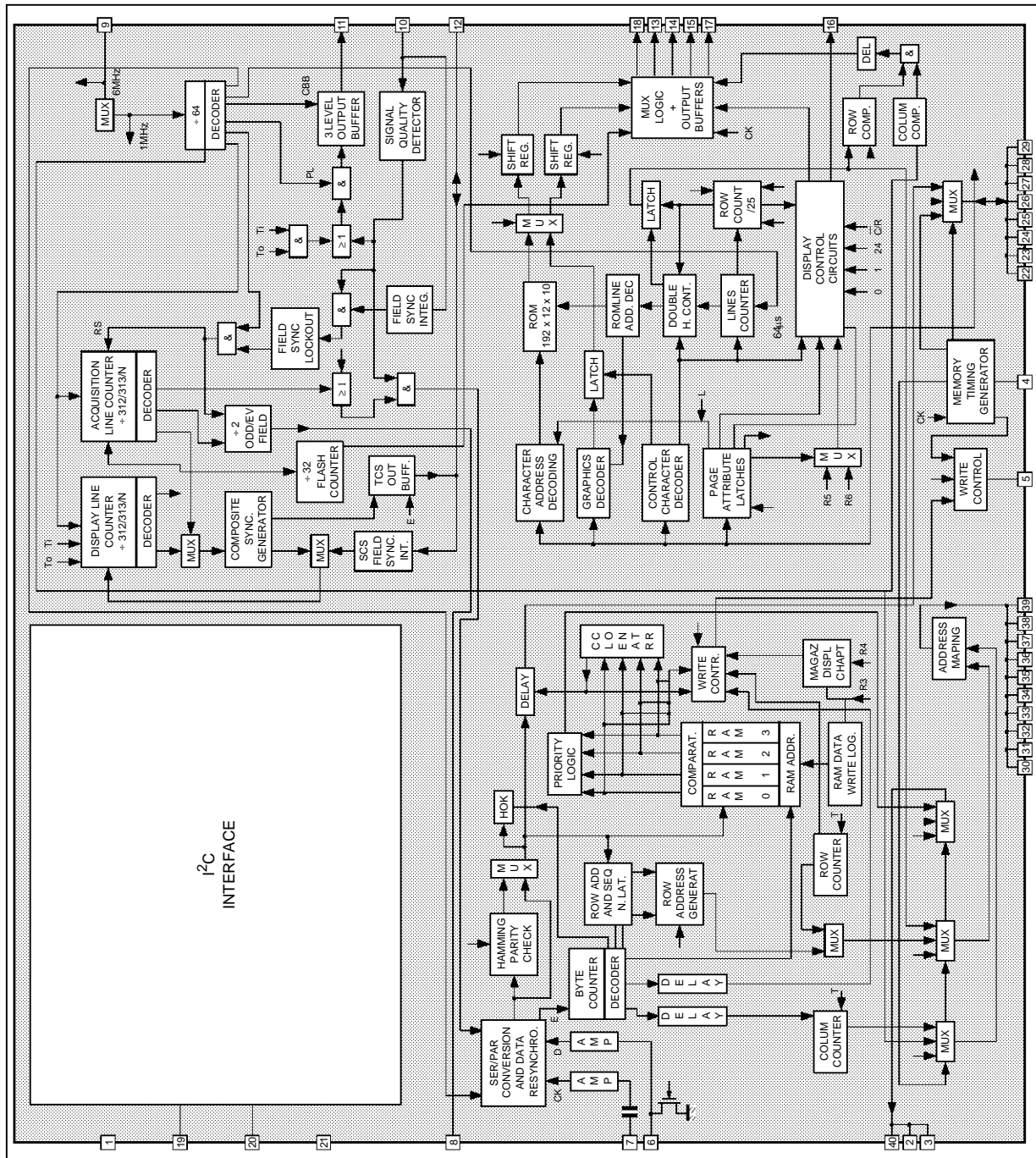

5243-02.EPS

SDA5243 - SDA5243/H

ABSOLUTE MAXIMUM RATINGS

Symbol	Parameter	Value	Unit
V _{DD}	Power Supply Range	-0.3, +7.5	V

INPUT VOLTAGE RANGE :

V _I	VCS, SDA, SCL, D0-D7 TTD, F6, TCS/SCS, TTC	-0.3, +7.5	V
		-0.3, +10	V

OUTPUT VOLTAGE RANGE :

V _O	SAND, A0-A12, OE, WE, D0-D7, SDA, ODD/EVEN, R, G, B, BLAN, COR, Y, TCS/SCS	-0.3, +7.5	V
		-0.3, +10	V
T _{stg}	Storage Temperature Range	-20, +125	°C
T _A	Operating Ambient Temperature Range	-20, +70	°C

5243-02.TBL

ELECTRICAL CHARACTERISTICS

V_{DD} = 5V, V_{SS} = 0V, T_A = - 20 to + 70°C

Symbol	Parameter	Min	Typ	Max	Unit
V _{DD}	Supply Voltage (pin 1)	4.5	5	5.5	V
I _{DD}	Supply Current	-	140	200	mA

INPUTS

TTD (Pin 6)					
C _{EXT}	Ext. Coupling Capacitor	-	-	50	nF
V _{I(p-p)}	Input Voltage p-p	2	-	7	V
t _r , t _f	Input Rise / Fall Times	10	-	80	ns
t _{DS}	Input Set-up Time	40	-	-	ns
t _{DH}	Input Hold Time	40	-	-	ns
I _{I(L)}	Input Leakage Current (V _I = 0 to 10V)	-	-	20	µA
C _I	Input capacitance	-	-	7	pF
TTC, F6 (Pins 7,9)					
V _I	DC Input Voltage	- 0.3	-	+10	V
V _{I(p-p)}	AC Input Voltage F6	1	-	7	V
	AC Input Voltage TTC	1.5	-	7	V
± V _P	Input Peak Rel. 50 % Duty	0.2	-	3.5	V
f _{TTC}	TTC Clock Frequency	4	6.9375	8	MHz
f _{F6}	F6 Clock Frequency	4	6	8	MHz
t _r , t _f	Clock Rise / Fall Times	10	-	80	ns
I _{I(L)}	Input Leakage Current (V _I = 0 to 10V)	-	-	20	µA
C _I	Input Capacitance	-	-	7	pF
VCS (Pin 10)					
V _{IL}	Low Level Input Voltage	0	-	0.8	V
V _{IH}	High Level Input Voltage	2	-	V _{DD}	V
t _r , t _f	Input Rise / Fall Times	-	-	500	ns
I _{I(L)}	Input Leakage Current (V _I = 5.5V)	-	-	10	µA
C _I	Input Capacitance	-	-	7	pF
SCL (Pin 19)					
V _{IL}	Low Level Input Voltage	0	-	1.5	V
V _{IH}	High Level Input Voltage	3	-	V _{DD}	V
f _{SCL}	SCL Clock Frequency	-	-	100	kHz
t _r , t _f	Input Rise / Fall Times	-	-	2	µs
I _{I(L)}	Input Leakage Current (V _I = 5.5V)	-	-	10	µA
C _I	Input Capacitance	-	-	7	pF

5243-03.TBL

ELECTRICAL CHARACTERISTICS (continued) $V_{DD} = 5V$, $V_{SS} = 0V$, $T_A = -20$ to $+70^{\circ}C$

Symbol	Parameter	Min	Typ	Max	Unit
INPUT/OUTPUTS					
\overline{TCS}(output), \overline{SCS}(input) (Pin12)					
V_{IL}	Low Level Input Voltage	0	-	1.5	V
V_{IH}	High Level Input Voltage	3	-	8	V
t_r, t_f	Input Rise / Fall Times	-	-	500	ns
$\pm I_{I(L)}$	Input Leakage Current ($V_I = 0$ to $5.5V$ and output in high impedance state)	-	-	10	μA
C_I	Input Capacitance	-	-	7	pF
V_{OL}	Low Level Output Voltage ($I_{OL} = 0.4mA$)	0	-	0.4	V
V_{OH}	High Level Output Voltage $-I_{OH} = 0.2mA$ $I_{OH} = 0.1mA$	2.4 2.4	- -	V_{DD} 5.5	V V
t_r, t_f	Output Rise / Fall Times between 0.6V and 2.2V	-	-	100	ns
C_I	Load Capacitance	-	-	50	pF
SDA (Pin 20) (see Figure 4)					
V_{IL}	Low Level Input Voltage	0	-	1.5	V
V_{IH}	High Level Input Voltage	3	-	V_{DD}	V
t_r, t_f	Input Rise / Fall Times	-	-	2	μs
$I_{I(L)}$	Input Leakage Current ($V_I = 5.5V$ with output off)	-	-	10	μA
C_I	Input Capacitance	-	-	7	pF
V_{OL}	Low Output Voltage ($I_{OL} = 3mA$)	0	-	0.5	V
t_f	Output Fall Time between 3.0V and 1.0V	-	-	200	ns
C_I	Load Capacitance	-	-	400	pF
D0-D7 (Pins 22-29), (see Figure 5)					
V_{IL}	Low Level Input Voltage	0	-	0.8	V
V_{IH}	High Level Input Voltage	2	-	V_{DD}	V
$\pm I_{I(L)}$	Input Leakage Current ($V_I = 0$ to $5.5V$ and output in high impedance state)	-	-	10	μA
C_I	Input Capacitance	-	-	7	pF
V_{OL}	Low Level Output Voltage ($I_{OL} = 1.6mA$)	0	-	0.4	V
V_{OH}	High Level Output Voltage ($-I_{OH} = 0.2mA$)	2.4	-	V_{DD}	V
t_r, t_f	Output Rise / Fall Times between 0.6V and 2.2V	-	-	50	ns
C_I	Load Capacitance	-	-	120	pF
OUTPUTS					
A0-A12, \overline{OE}, \overline{WE} (Pins 30-40,2,3,4,5,)					
V_{OL}	Low Level Output Voltage ($I_{OL} = 1.6mA$)	0	-	0.4	V
V_{OH}	High Level Output Voltage ($-I_{OH} = 0.2mA$)	0.4	-	V_{DD}	V
t_r, t_f	Output Rise / Fall Times between 0.6V and 2.2V	-	-	50	ns
C_L	Load Capacitance	-	-	120	pF
ODD/EVEN (Pin 8)					
V_{OL}	Low Level Output Voltage ($I_{OL} = 0.4mA$)	0	-	0.4	V
V_{OH}	High Level Output Voltage ($-I_{OH} = 0.2mA$)	2.4	-	V_{DD}	V
t_r, t_f	Output Rise / Fall Times between 0.6V and 2.2V				
C_L	Load Capacitance				

5243-04.TBL

SDA5243 - SDA5243/H

ELECTRICAL CHARACTERISTICS (continued)

$V_{DD} = 5V$, $V_{SS} = 0V$, $T_A = -20$ to $+70^{\circ}C$

Symbol	Parameter	Min	Typ	Max	Unit
--------	-----------	-----	-----	-----	------

OUTPUTS

SAND (Pin 11)(see Figure 1)					
V_{OL}	Low Level Output Voltage ($I_{OL} = 0.2mA$)	0	-	0.25	V
V_{OI}	Middle Level Output Voltage ($I_{OL} = \pm 10 \mu A$)	1.1	-	2.9	V
V_{OH}	High Level Output Voltage ($I_{OH} = 0/-10\mu A$)	4	-	V_{DD}	V
t_{r1} t_{r2}	Output Rise Time : V_{OL} to V_{OI} from 0.4 to 1.1V V_{OI} to V_{OH} from 2.9 to 4.0V	-	-	400 200	ns
t_f	Output Fall Time V_{OH} to V_{OI} from 4.0 to 0.4V	-	-	50	ns
C_l	Load Capacitance	-	-	30	pF
R, G, B, \overline{COR} , BLAN, Y (Pins 13-18), (see Figure 4)					
V_{OL}	Low Level Output Voltage : $I_{OL} = 2mA$ $I_{OL} = 5mA$	0 0	- -	0.4 1	V
V_{PU}	Pull-up Voltage (with $R = 1k\Omega$ to 5V)	-	-	5	V
t_f	Output Fall Time from 4.5 to 1.5V (with $R = 1k\Omega$ to 5V)	-	-	20	ns
t_{sk}	Skew Delay on Falling Edges (at 3V with $R = 1k\Omega$ connected to 5V)	-	-	20	ns
C_L	Load Capacitance	-	-	25	pF
I_{LO}	Output Leakage Current ($V_{PU} = 0$ to 6V output off)	-	-	20	μA

TIMING

SERIAL BUS (referred to $V_{IH} = 3V$, $V_{IL} = 1.5V$)					
t_{LOW}	Low Period Clock	4	-	-	μs
t_{HIGH}	High Period Clock	4	-	-	μs
t_{SU}, d_{AT}	Data Set-up Time	250	-	-	ns
t_{HD}, d_{AT}	Data Hold Time	170	-	-	ns
t_{SU}, s_{TO}	Stop Set-up Time from Clock High	4	-	-	μs
t_{BUF}	Start Set-up Time Following a Stop	4	-	-	μs
t_{HD}, s_{TA}	Start Hold Time	4	-	-	μs
t_{SU}, s_{TA}	Start Set-up Time Following Clock Low to High Transition	4	-	-	μs
MEMORY INTERFACE referred to $V_{IL} = 1.5V$					
t_{CY}	Cycle Time	-	500	-	ns
t_{OE}	Adress Change to \overline{OE} Low	60	-	-	ns
t_{ADDR}	Address Active Time	450	500	-	ns
t_{OEw}	\overline{OE} Pulse Duration	320	-	-	ns
t_{ACC}	Access Time from \overline{OE} to Data Valid	-	-	200	ns
t_{DH}	Data Hold Time from \overline{OE} High or Address Change	0	-	-	ns
t_{WE}	Address Change to \overline{WE} Low	40	-	-	ns
t_{WEw}	\overline{WE} Pulse Duration	200	-	-	ns
t_{DS}	Data Set-up Time to \overline{WE} High	100	-	-	ns
t_{DHW}	Data Hold Time from \overline{WE} High	20	-	-	ns
t_{WR}	Write Recovery Time	25	-	-	ns

5243-05.TBL

Figure 1 : F6, TTC, TTD Input Internal Connections

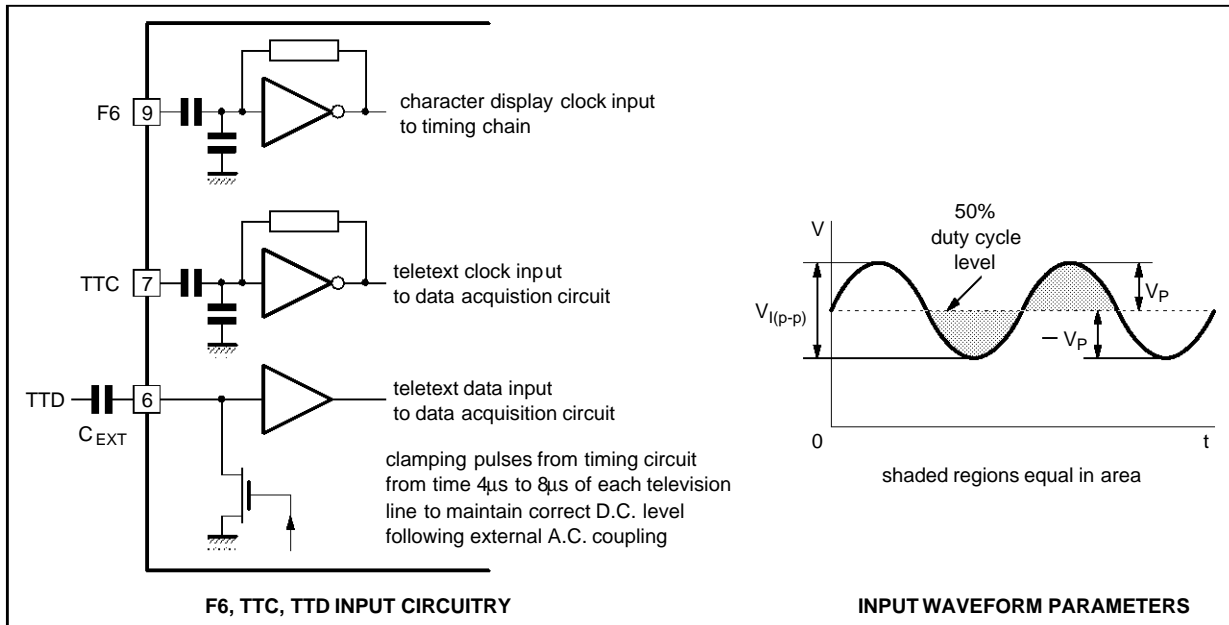

5243-03.EPS

Figure 2 : Teletext Data Input Timing

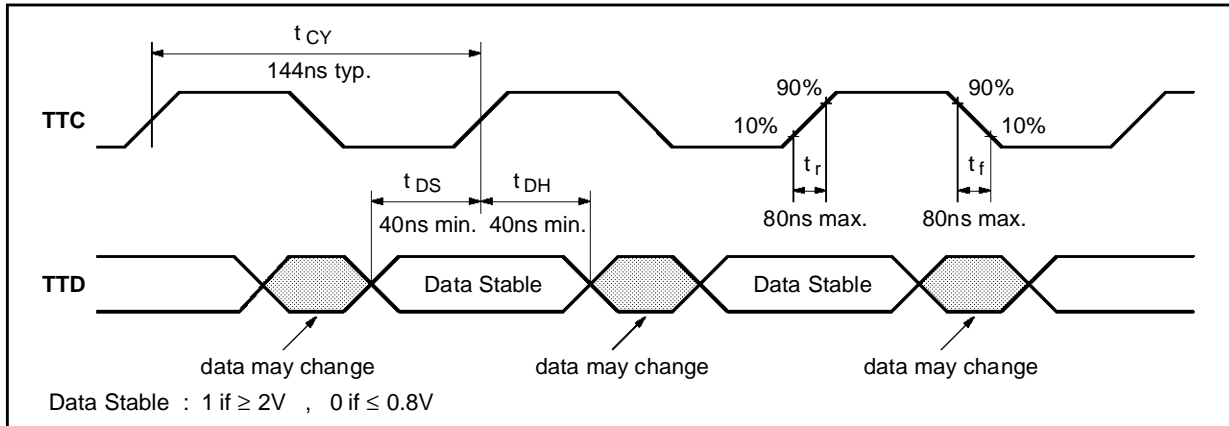

5243-04.EPS

Figure 3 : Synchronization Timing

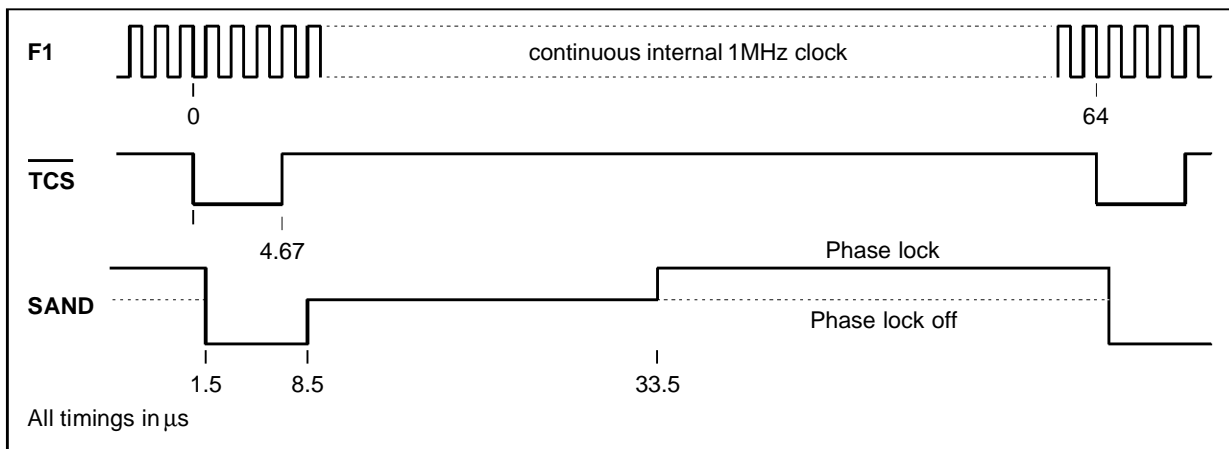

5243-05.EPS

Figure 4 : Composite Sync. Waveforms

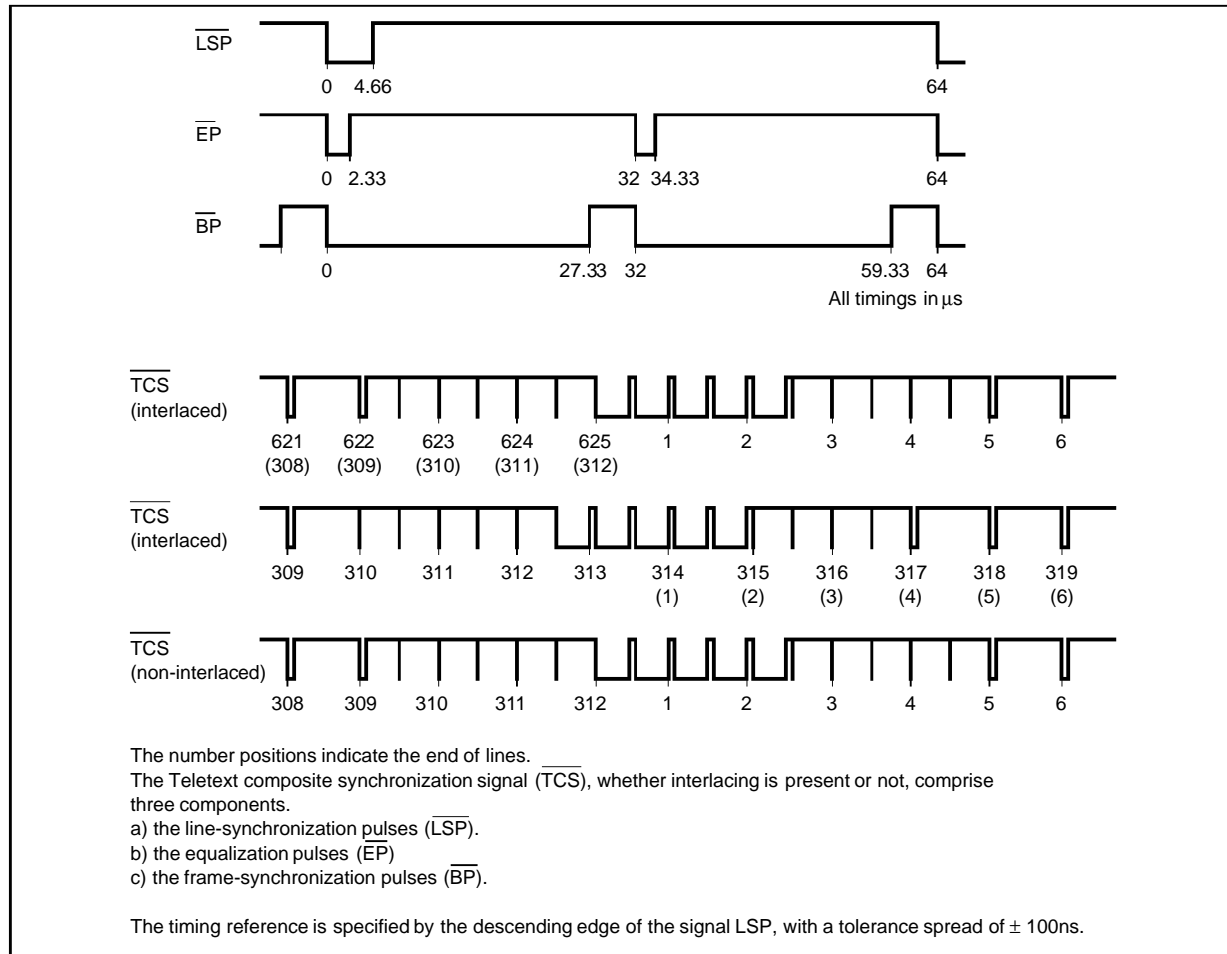

5243-06.EPS

Figure 5 : Display Output Timing

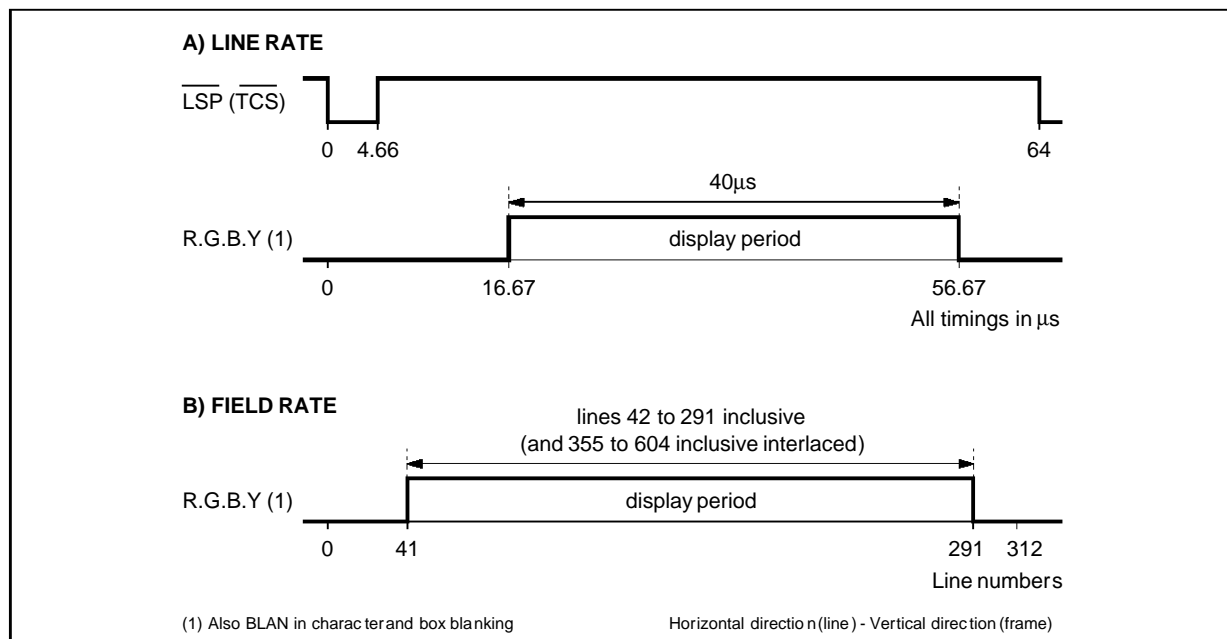

5243-07.EPS

Figure 6 : Serial Bus Timing

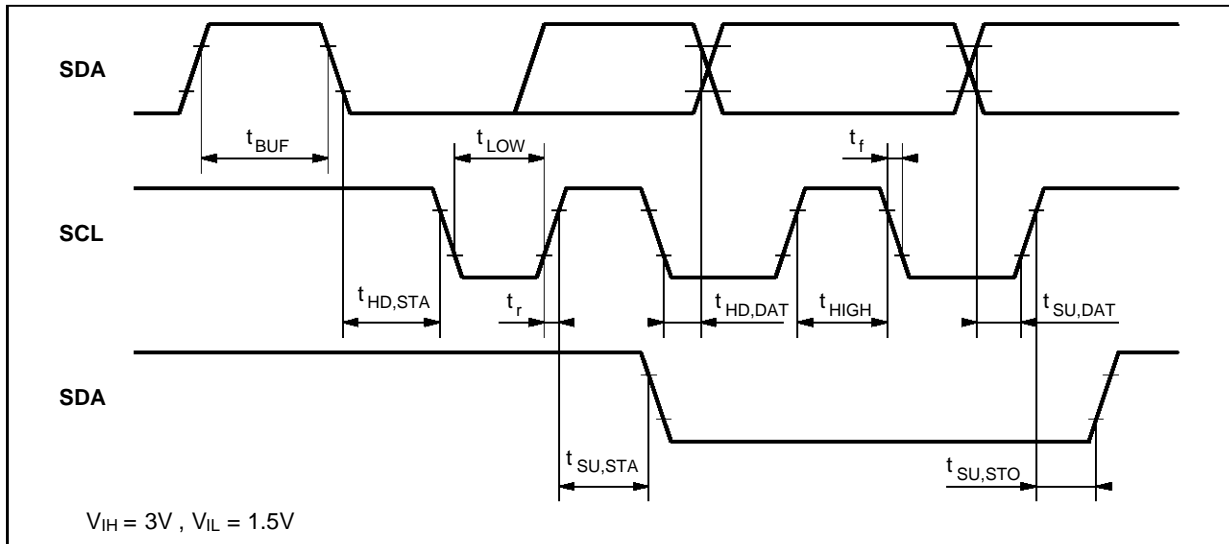

5243-08.EPS

Figure 7 : Memory Interface Timing

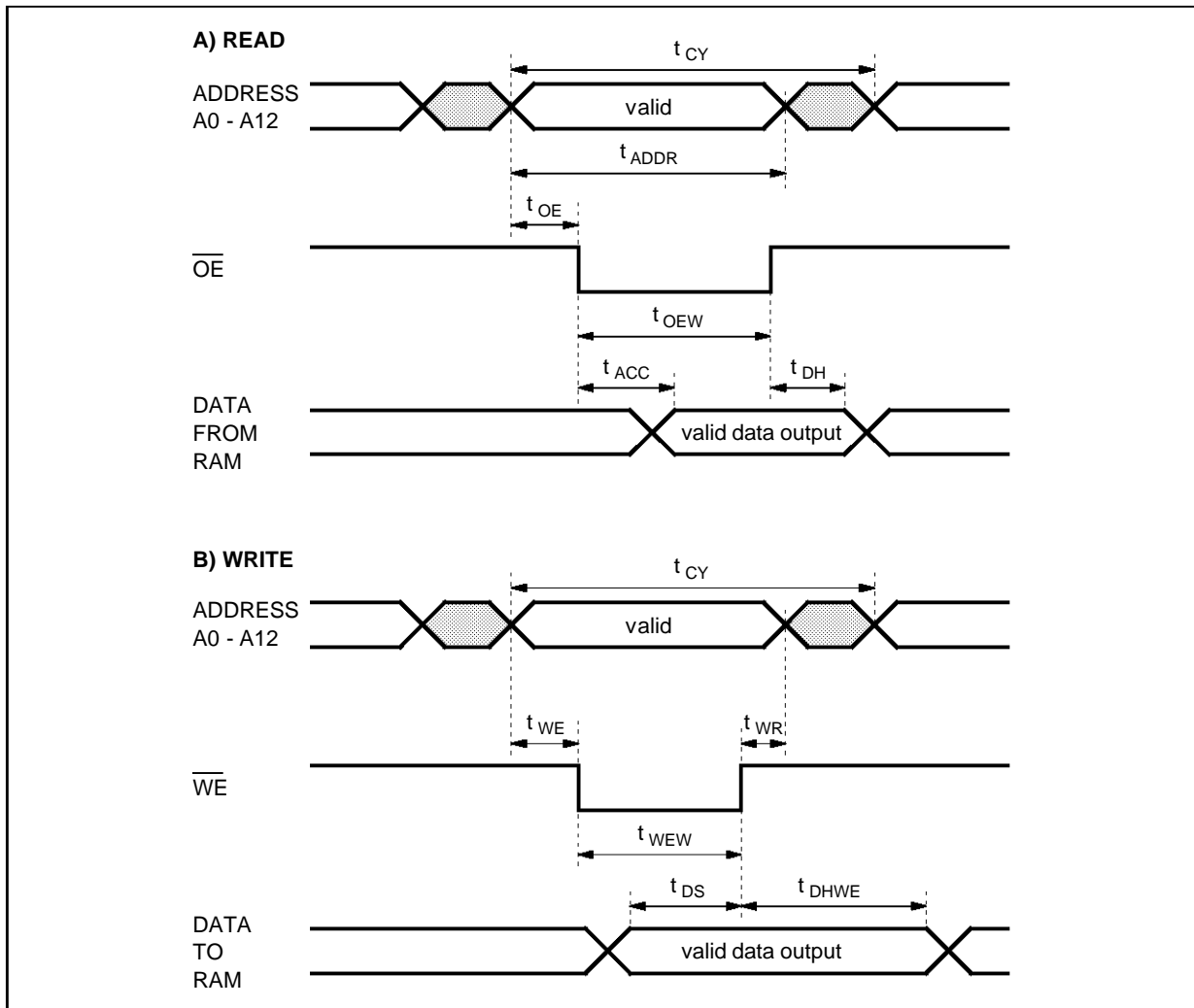

5243-09.EPS

APPLICATION NOTES

ORGANIZATION OF A PAGE-MEMORY

The organization of a page-memory is shown in Figure 6. In contrast with the first generation of Teletext Decoders the new CCT (Computer Controlled Teletext) chip provides a display format of 25 rows of 40 characters per row.

Row number twenty-four is used by the microprocessor for the display of information.

Row zero contains the page header.

The organization is as follows :

The first seven characters (0 - 6) are used for messages regarding the operational status.

The eighth character is an alphanumeric control

character either "white" or "green" defining the "search" status of the page. When it is "white" the operational state is normal and the header appears white ; when it is "green" the operational state corresponds to "search mode" and the header appears green. The following twenty-four characters give the header of the requested page when the system is in search mode. The last eight characters display the time of day.

Row twenty-five comprises ten bytes of control data concerning the received page (see Table 1) and fourteen free bytes which can be used by the microprocessor.

PAGE MEMORY ORGANIZATION

Figure 8

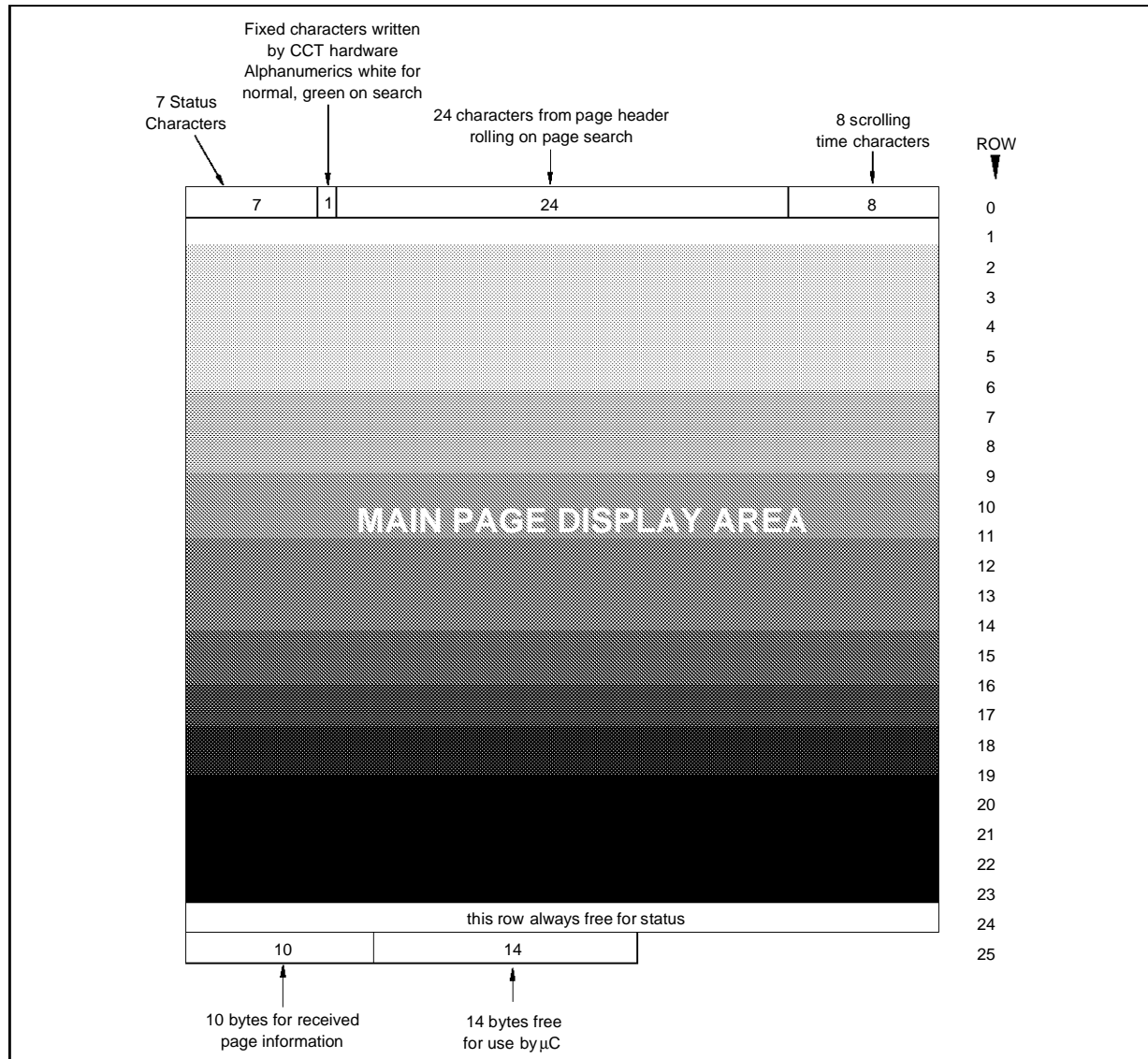

5243-11.EPS

Table 1 : Row 25 received control data format

D0	PU0	PT0	MU0	MT0	HU0	HT0	C7	C11	MAG0	0
D1	PU1	PT1	MU1	MT1	HU1	HT1	C8	C12	MAG1	0
D2	PU2	PT2	MU2	MT2	HU2	C5	C9	C13	MAG2	0
D3	PU3	PT3	MU3	C4	HU3	C6	C10	C14	0	0
D4	HAM	HAM	HAM	HAM	HAM	HAM	HAM	HAM	FOUND	0
D5	0	0	0	0	0	0	0	0	0	PBLF
D6	0	0	0	0	0	0	0	0	0	0
D7	0	0	0	0	0	0	0	0	0	0
COLUMN	0	1	2	3	4	5	6	7	8	9

Page number : - MAG = magazine, PU = page units, PT = page tens.
 Page sub-code : - MU = minutes units, MT = minutes tens, HU = hours units, HT = hours tens.
 PBLF = page being looked for, FOUND = low for page found, HAM = hamming error in byte, C4-14 = control bits.

5243-106.TBL

REGISTER MAP (see Table 2)

Registers R1 to R10 are write only whilst R11 is a read/write register respect to the microprocessor. The automatic succession on a byte basis is indicated by the arrows in Table 2. In the normal operating mode TA and TB should be set to logic level 0. After power-up the contents of the registers are as

follows : all bits in registers R1 to R10 are cleared to zero with the exception of bits D0 and D1 in registers R5 and R6 which are set to logical one. After power-up all the memory bytes are preset to hexadecimal value 20 H (space) with the exception of the byte corresponding to row 0 of column 7 of chapter 0 which is set to the value corresponding to "alpha white" hexadecimal value 07 H.

Table 2 : Register specification

D7	D6	D5	D4	D3	D2	D1	D0		
TA	7 + P/ 8 BIT	ACQ. ON/OFF	GHOST ROW ENABLE	DEW/ FULL FIELD	TCS ON	T1	T0		R1 Mode
-	BANK SELECT A2	ACQ. CCT A1	ACQ. CCT A0	TB	START COLUMN SC2	START COLUMN SC1	START COLUMN SC0		R2 Page request address
-	-	-	PRD4	PRD3	PRD2	PRD1	PRD0		R3 Page request data
-	-	-	-	-	A2	A1	A0		R4 Display chapter
BKGND OUT	BKGND IN	COR OUT	COR IN	TEXT OUT	TEXT IN	PON OUT	PON IN		R5 Display control (normal)
BKGND OUT	BKGND IN	COR OUT	COR IN	TEXT OUT	TEXT IN	PON OUT	PON IN		R6 Display control (newsflash / subtitle)
STATUS ROW BTM/TOP	CURSOR ON	CONCEAL/ REVEAL	TOP/ BOTTOM	SINGLE/ DOUBLE HEIGHT	BOX ON 24	BOX ON 1-23	BOX ON 0		R7 Display mode
-	-	-	-	CLEAR MEM.	A2	A1	A0		R8 Active chapter
-	-	-	R4	R3	R2	R1	R0		R9 Active row
-	-	C5	C4	C3	C2	C1	C0		R10 Active column
D7 (R/W)	D6 (R/W)	D5 (R/W)	D4 (R/W)	D3 (R/W)	D2 (R/W)	D1 (R/W)	D0 (R/W)		R11 Active data

- bit does not exist

5243-07.TBL

REGISTER FUNCTIONS

Register	Function	Bit(s)	Description
R1	Mode controls	T0,T1 (D0,D1)	These bits control the frame display format. Interlaced or non-interlaced,312/313 or 312/312.
		TCS ON (D2)	This bit determines the character display synchronization mode. Teletext composite synchronism (TCS ON = 1) or direct broadcast synchronism (TCS ON = 0).
		DEW/FULLFIELD (D3)	Selection of field flyback mode or full channel mode (D3 = 1) for recovering of Teletext data.
		GHOST ROW ENABLE (D4)	Selection of ghost row mode (D4 = 1)
		ACQUISITION ON/OFF (D5)	Control of acquisition operation (D5 = 0 enables acquisition)
		7 bits + parity or 8 bits without parity (D6)	Selection of received data format either 7 bits with parity (D6 = 0) or 8 bits without parity (D6 = 1).
		TA (D7)	Test bit equal to "0" in the normal operating mode.
R2	Addressing information for a page request	SC0,SC1,SC2 (D0,D1,D2)	Address the first column of the on chip page request RAM to be written.
		TB (D3)	Test bit equal to "0" in the normal working mode.
		A0,A1 (D4,D5)	Address a group of four consecutive pages currently used for data acquisition;
		A2 (D6)	Address of one of the two groups of four pages for acquisition in normal mode.
R3	Data relative to the requested page (see Table 3).	PRD0-PRD4 (D0-D4)	Written data in the page request RAM, starting with the columns addressed by SC0,SC1,SC2.
R4	Selection of one of eight pages to display.	A0,A1,A2 (D0,D1,D2)	These three bits correspond to the logical states of the three address lines (A12,A11,A10) during memory read cycles.
R5	Display control for normal operation.	PON (D0,D1)	Picture on (IN: D0, OUT: D1)
		TEXT (D2,D3)	Text on (IN: D2, OUT: D3)
		COR (D4,D5)	Contrast reduction on (IN: D4, OUT: D5)
		BKGND (D6,D7)	Background colour on (IN: D6, OUT: D7)
		IN/OUT	Enable inside/outside the box
R6	Display control for news-flash subtitle generation.	See R5	See R5
R7	Display mode	BOX ON 0,1-23,24 (D0,D1,D2)	The "boxing" function is enabled on row 0,1-23 and 24 by D0, D1 and D2 set to one.
		STATUS ROW BTM/TOP (D7)	The 25th row is displayed before the "Main text Area" (lines 0-23) or after (D7 = 0).
R8 to R11	Active chapter address (R8), active row address (R9), active column address (R10). Data contained in R11 read (written) from (to) memory by microprocessor via I ² C bus.		

5243-08.TBL

Table 3 : Register R3

START COLUMN	PRD4	PRD3	PRD2	PRD1	PRD0
0	Do care magazine	HOLD	MAG2	MAG1	MAG0
1	Do care page tens	PT3	PT2	PT1	PT0
2	Do care page units	PU3	PU2	PU1	PU0
3	Do care hours tens	X	X	HT1	HT0
4	Do care hours units	HU3	HU2	HU1	HU0
5	Do care minutes tens	X	MT2	MT1	MT0
6	Do care minutes units	MU3	MU2	MU1	MU0

The abbreviations have the same significance as in Table 1 with the exception of the "DO CARE" entries. It is only when this bit is "1" that the corresponding digit is taken into consideration on page request. For example, a page defined as "normal" or one defined as "timed" may be selected.
 If "HOLD" is low the page is held. The addressing of successive bytes via the I²C bus is automatic.

5243-08.TBL

CHARACTER SETS

The complete character set with 8-bit decoding is given in Table 4.

Characters in columns 0 and 1 are normally displayed as blanks. Black dots represent the character shape whereas white dots represent the background.

Each character can be identified by a pair of corre-

sponding row and column integers : for example the character "3" may be indicated by 3/3.

A rectangle may be represented as follows :

The characters 8/6, 8/7, 9/5, 9/7 are used as special characters, always in conjunction with 8/5.

The 13 national characters are placed in columns with bit 8 = 0.

Table 4b : Complete character set (with 8 bit codes) - East European Languages

B	T	S	b ₄ b ₃ b ₂ b ₁	column	0	1	0 or 1	2a	3	3a	4	5	6	6a	7	7a	8	9	12	13	14	15
0	0	0	0	0	alphanumerics black	graphics black	0		0	0	T	P	t				S	E	É	À	Œ	Ë
0	0	0	0	1	alphanumerics red	graphics red	0	!	1	1	A	Q	a	A	Q	Q	°	É	É	À	Œ	Ë
0	0	1	0	2	alphanumerics green	graphics green	0	"	0	0	B	R	b	B	R	R	°	É	É	À	Œ	Ë
0	0	1	1	3	alphanumerics yellow	graphics yellow	0	#	0	0	C	S	c	C	S	S	°	É	É	À	Œ	Ë
0	1	0	0	4	alphanumerics blue	graphics blue	0	¤	0	0	D	T	d	D	T	T	°	É	É	À	Œ	Ë
0	1	0	1	5	alphanumerics magenta	graphics magenta	0	%	0	0	E	U	e	E	U	U	°	É	É	À	Œ	Ë
0	1	1	0	6	alphanumerics cyan	graphics cyan	0	&	0	0	F	V	f	F	V	V	°	É	É	À	Œ	Ë
0	1	1	1	7	alphanumerics white	graphics white	0	'	0	0	G	W	g	G	W	W	°	É	É	À	Œ	Ë
1	0	0	0	8	flash	conceal display	1	(0	0	H	X	h	H	X	X	°	É	É	À	Œ	Ë
1	0	0	1	9	steady	continuous graphics	1)	0	0	I	Y	i	I	Y	Y	°	É	É	À	Œ	Ë
1	0	1	0	10	end box	separated graphics	1	*	0	0	J	Z	j	J	Z	Z	°	É	É	À	Œ	Ë
1	0	1	1	11	start box	ESC	1	+	0	0	K	[k	K	[[°	É	É	À	Œ	Ë
1	1	0	0	12	normal height	black background	**	,	0	0	L]	l	L]]	°	É	É	À	Œ	Ë
1	1	0	1	13	double height	new background	**	-	0	0	M	^	m	M	^	^	°	É	É	À	Œ	Ë
1	1	1	0	14	SO	hold graphics	*	.	0	0	N	_	n	N	_	_	°	É	É	À	Œ	Ë
1	1	1	1	15	SI	release graphics	**	/	0	0	O	~	o	O	~	~	°	É	É	À	Œ	Ë

Case using C12 C13 C14 = 111 (Rumanian Set)

* These control characters are reserved for compatibility with other data codes.

** These control characters are presumed before each row begins

NATIONAL OPTION CHARACTER SETS

The basic set of the 96 characters is shown in Table 5. The location of the 13 national characters

are shown in Table 5 whilst full national character sets are depicted in Tables 6 and 7.

Table 5 : Basic character set.

2/0		3/0		4/0	National Character	5/0		6/0	National Character	7/0	
2/1		3/1		4/1		5/1		6/1		7/1	
2/2		3/2		4/2		5/2		6/2		7/2	
2/3	National Character	3/3		4/3		5/3		6/3		7/3	
2/4	National Character	3/4		4/4		5/4		6/4		7/4	
2/5		3/5		4/5		5/5		6/5		7/5	
2/6		3/6		4/6		5/6		6/6		7/6	
2/7		3/7		4/7		5/7		6/7		7/7	
2/8		3/8		4/8		5/8		6/8		7/8	
2/9		3/9		4/9		5/9		6/9		7/9	
2/10		3/10		4/10		5/10		6/10		7/10	
2/11		3/11		4/11		5/11	National Character	6/11		7/11	National Character
2/12		3/12		4/12		5/12	National Character	6/12		7/12	National Character
2/13		3/13		4/13		5/13	National Character	6/13		7/13	National Character
2/14		3/14		4/14		5/14	National Character	6/14		7/14	National Character
2/15		3/15		4/15		5/15	National Character	6/15		7/15	

Table 6 : Character Set for SDA5243 West European Languages

LANGUAGE	PHCB (1)			CHARACTER POSITION (COLUMN/ROW)												
	C12	C13	C14	2/3	2/4	4/0	5/11	5/12	5/13	5/14	5/15	6/0	7/11	7/12	7/13	7/14
ENGLISH	0	0	0													
GERMAN	0	0	1													
SWEDISH	0	1	0													
ITALIAN	0	1	1													
FRENCH	1	0	0													
SPANISH	1	0	1													

5243-16.EPS

Note 1 : Where PHCB are the Page Header Control bits. Other Combinations default to English. Only the above characters change with the PHCB. All others characters in the basic set are shown in Table 5.

Table 7 : Character Set for SDA5243 East European Languages

LANGUAGE	PHCB (1)			CHARACTER POSITION (COLUMN/ROW)												
	C12	C13	C14	2/3	2/4	4/0	5/11	5/12	5/13	5/14	5/15	6/0	7/11	7/12	7/13	7/14
POLISH	0	0	0													
GERMAN	0	0	1													
SWEDISH	0	1	0													
SERBO-CROAT	0	1	1													
CZECHOSLOVAK	1	0	0													
RUMANIAM	1	0	1													

5243-16.EPS

Note 1 : Where PHCB are the Page Header Control bits. Other Combinations default to German. Only the above characters change with the PHCB. All others characters in the basic set are shown in Table 5.

Figure 9 : Character Format

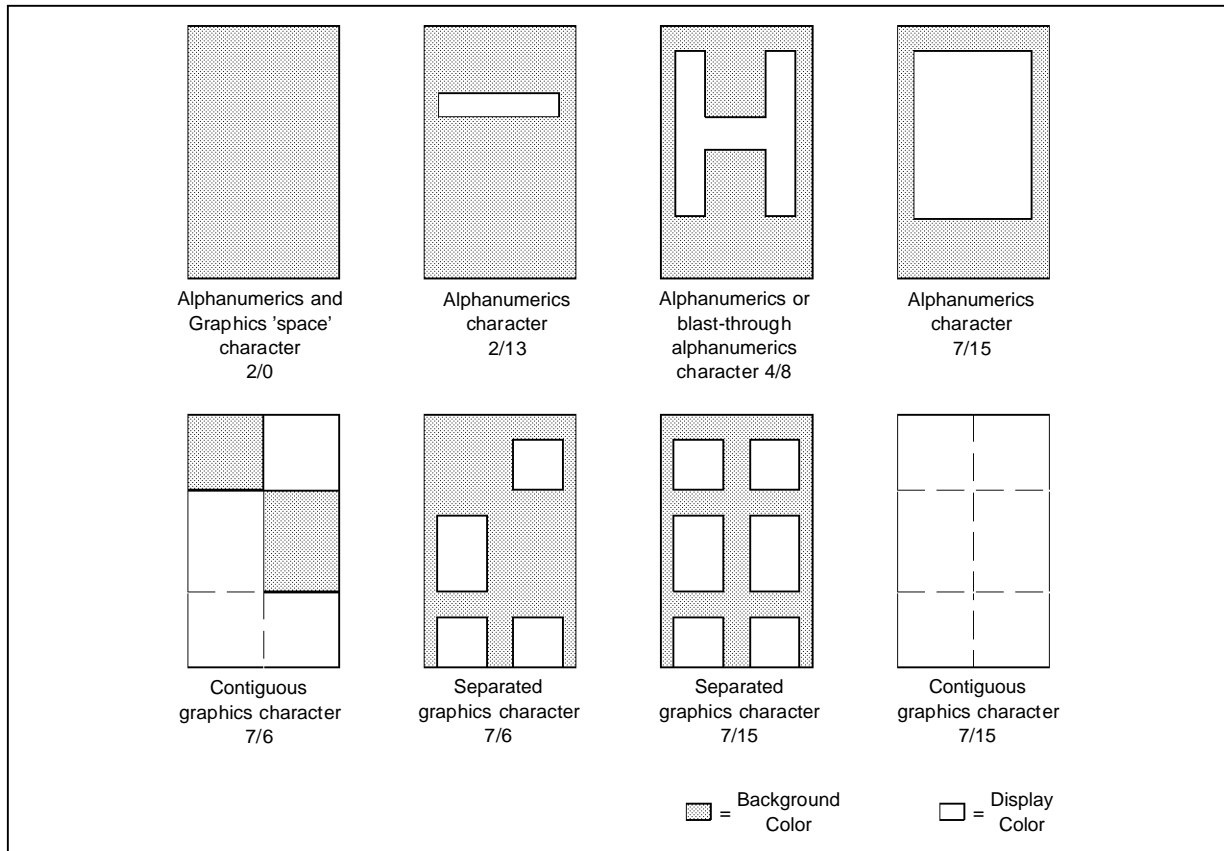

5243-17.EPS

SDA5243 - SDA5243/H

PACKAGE MECHANICAL DATA

40 PINS - PLASTIC DIP

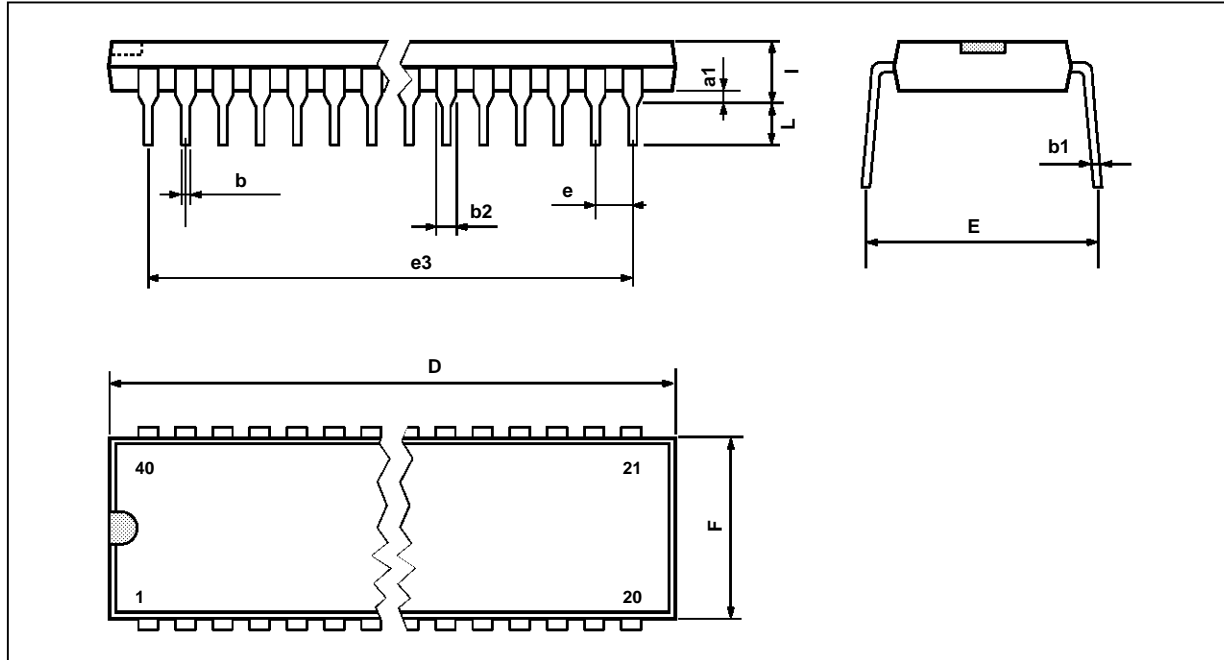

Dimensions	Millimeters			Inches		
	Min.	Typ.	Max.	Min.	Typ.	Max.
a1		0.63			0.025	
b		0.45			0.018	
b1	0.23		0.31	0.009		0.012
b2		1.27			0.050	
D			52.58			2.070
E	15.2		16.68	0.598		0.657
e		2.54			0.100	
e3		48.26			1.900	
F			14.1			0.555
i		4.445			0.175	
L		3.3			0.130	

Information furnished is believed to be accurate and reliable. However, SGS-THOMSON Microelectronics assumes no responsibility for the consequences of use of such information nor for any infringement of patents or other rights of third parties which may result from its use. No licence is granted by implication or otherwise under any patent or patent rights of SGS-THOMSON Microelectronics. Specifications mentioned in this publication are subject to change without notice. This publication supersedes and replaces all information previously supplied. SGS-THOMSON Microelectronics products are not authorized for use as critical components in life support devices or systems without express written approval of SGS-THOMSON Microelectronics.

© 1994 SGS-THOMSON Microelectronics - All Rights Reserved

Purchase of I²C Components of SGS-THOMSON Microelectronics, conveys a license under the Philips I²C Patent. Rights to use these components in a I²C system, is granted provided that the system conforms to the I²C Standard Specifications as defined by Philips.

SGS-THOMSON Microelectronics GROUP OF COMPANIES

Australia - Brazil - China - France - Germany - Hong Kong - Italy - Japan - Korea - Malaysia - Malta - Morocco
The Netherlands - Singapore - Spain - Sweden - Switzerland - Taiwan - Thailand - United Kingdom - U.S.A.