

DATASHEET

AXP202

Single Cell Li-Battery PWM Charger and Power System Management IC

X-Powers

© 2010 X-Powers Limited - All rights reserved

## 1 · Introduction

AXP202 is designed to be a highly-integrated power system management IC that is optimized for applications requiring single-cell Li-battery (Li-Ion/Polymer) and multiple output DC-DC converters. It is offering an easy-to-use and flexible complete solution which can fully meet the increasingly complexity of accurate power control required by modern application processor system.

AXP202 comprises an adaptive USB-Compatible PWM charger, 2 BUCK DC-DC converters, 5 LDOs, multiple 12-bit ADCs of Voltage, current and temperature as well as 4 configurable GPIOs. To guarantee the safety and stability of power system, AXP202 has integrated various protection circuits such as Over voltage Protection(OVP)/Under voltage Protection(UVP)、Over temperature protection(OTP)、Over current protection(OCP).

With Intelligent Power Select, IPS™ circuits, AXP202 can distribute power safely and transparently among external AC-adapter, Li-battery and loaded application system, and it can still work normally when there is no battery (deeply discharged/infective battery) but only external input power source.

The AXP202 provides a small, simple solution for obtaining power from three different power sources, single-cell Li-Ion battery, USB port, and AC-adapter, and it can support rechargeable backup battery too.

To ensure compatibility with a wide range of system processors, AXP202 uses a sTwo Wire Serial Interface (TWSI),through which application processor is capable of enabling/disabling power rails, programming voltage, visiting internal registers as well as measurement data (including Fuel Gauge). With the power monitoring results of high precision (1%, determined by the 1% BIAS resistance), end users will be always posted with the real-time power consumption, which can bring them an unprecedented experiences of power management.

AXP202 is available in a 6mm x 6mm 48-pin QFN package.

### Product Application

- Portable Handset:  
Smartphone, PMP/MP4, Digital Camera, Digital Camcorder, PND, PDA, PTV
- Mobile Connected Devices such as xPad,MID
- DPF, Portable DVD Player ,  
Ultra Mobile UMPC and UMPC-like, Entertainment and Education Machine
- Application Processor systems
- Other battery and multi-power svstems

### Pin Description

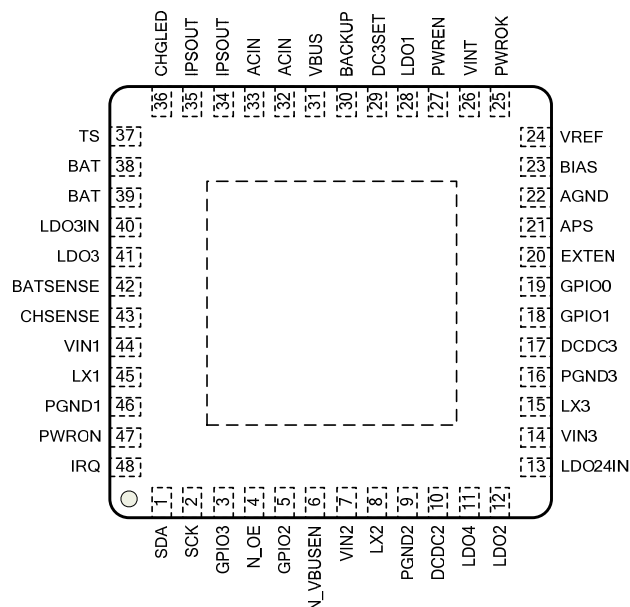

## 2. Feature

- **Intelligent Power Select(IPS)**
  - Wide input Voltage  
2.9V~6.3V (AMR: -0.3V~11V)
  - Configurable highefficient IPS system
  - Adaptive USB(supporting USB3.0) or AC-adaptor with voltage/current-limit (4.4V/900mA/500mA/100mA)
  - Equivelent Resistance of Batter Power Path less than 75mΩ
- **Fully Integrated PWM Charger**
  - Max Charge Current up to 1.8A
  - Support Battery Temperature Monitoring
  - Support USB compatible charger( supporting USB3.0)
  - Support Battery of Various Voltage such as 4.1V/4.15V/4.2V/4.36V
  - Automatic Charge Procedure Management
  - Directly drive LED to indicate charge status
  - Automatical scaling of charge current according to the System Load
- **Backup Battery**
  - Backup Battery to Supply Power for RTC
  - Support Backup Battery Charge with Adjustable Charge Current
- **2 Synchronous Duck DC-DC**
  - DC-DC1 : PWM Charger
  - DC-DC2 : 1.6A ,with Voltage from 0.7V to 2.275V and 25mV/step, supporting Voltage Ramp Control(VRC)
  - DC-DC3 : 1.2A with Voltage from 0.7V to 3.5V and 25mV/step
- **5 Low-dropout Linear Regulator(LDO)**
  - LDO1:Always-on 30mA LDO1
  - LDO2:200mA Low Noise with voltage from 1.8V to 3.3V and 100mV/step
  - LDO3:200mA with Voltage from 0.7V to 3.5V and 25mV/step
  - LDO4:200mA Low Noise with voltage from 1.8V to 3.3V and 100mV/step
  - LDO5:50mA Low Noise with voltage from 1.8V to 3.3V and 100mV/step
- **Signal Capture System**
  - 12 channel on-chip 12-bit ADC
  - Support 2 external signal input
  - Provide Battery and External Input Power Current and Voltage
  - On-chip Coulometer and Fuelgauge with High Precision
  - Provide Various Power Management data such as Transient Power Consumption(mA or mW), Remaining Battery Life(% or mAh), Charge State(%) and Charge Time
  - Two-level Low-Power Warning & Protection
  - Provide AXP202 Die Temperature
- **Host Interface**
  - Host can exchange data with PMIC via TWISI
  - Flexible Interrupts and Sleep Management
  - Flexible Pin Function Configuration. Multiple GPIO can be set as IO, ADC and so on
  - On-chip Configurable Timer
  - 12 Registers for Data storage during System Power-off
- **System Management**
  - Support Soft Reset and Hard Reset
  - Support Soft Power-off and Hard Power-off
  - Support Exteranl Wakeup Triggers
  - Support Output Voltage Monitoring and Self-Diagnosis
  - Output PWROK indicating System Reset or Power-off
  - External Power Detection(Plugin/Removal/Inqualified Drive Capability)
  - Support Soft Power-on for Input & Output
  - Overvoltage/Undervoltage Protection(OVP/UVP)
  - Overcurrent Protection(OCP)
  - Overtemperature Protection(OTP)
  - Support OTG VBUS Power State Setting/Monitoring
- **Highly Integration**
  - Internal Reference Voltage with High Accuracy (0.5%)
  - On-chip MOSFET
  - Customizable Timing and Output Voltage

## 3. Typical Application

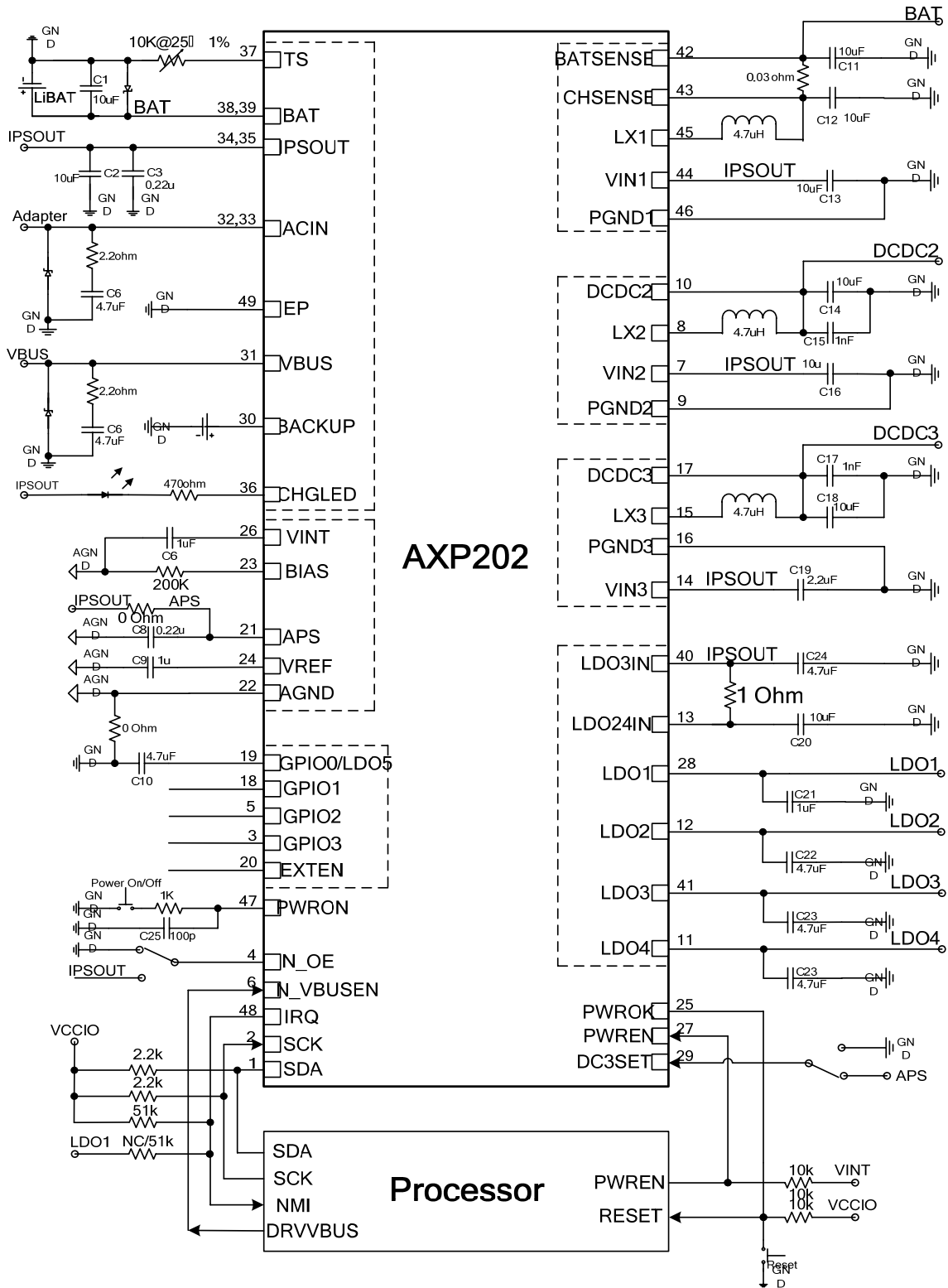

## 4 . Absolute Maximum Ratings

Symbol	Description	Value	Units
ACIN	Input Voltage	-0.3 to 11	V
VBUS	Input Voltage	-0.3 to 11	V
T <sub>J</sub>	Operating Temperature Range	-40 to 130	°C
T <sub>s</sub>	Storage Temperature Range	-40 to 150	°C
T <sub>LEAD</sub>	Maximum Soldering Temperature (at leads, 10sec)	300	°C
V <sub>ESD</sub>	Maximum ESD stress voltage, Human Body Model	>4000	V
P <sub>D</sub>	Maximum Power Dissipation	2100	mW

## 5 . Electrical Characteristics

V<sub>IN</sub> =5V, BAT=3.8V, T<sub>A</sub>= 25°C

SYMBOL	DESCRIPTION	CONDITIONS	MIN	TYP	MAX	UNITS
<b>ACIN</b>						
V <sub>IN</sub>	ACIN Input Voltage		3.8		6.3	V
I <sub>OUT</sub>	V <sub>OUT</sub> Current Available Before Loading BAT	500mV Voltage Drop		2500		mA
V <sub>UVLO</sub>	ACIN Under Voltage Lockout			3.8		V
V <sub>OUT</sub>	IPS Output Voltage		2.9		5.0	V
R <sub>ACIN</sub>	Internal Ideal Diode On Resistance	PIN to PIN, ACIN to IPSOUT			170	mΩ
<b>VBUS</b>						
V <sub>IN</sub>	VBUS Input Voltage		3.8		6.3	V
I <sub>OUT</sub>	V <sub>OUT</sub> Current Available Before Loading BAT			500	900	mA
V <sub>UVLO</sub>	VBUS Under Voltage Lockout			3.8		V
V <sub>OUT</sub>	IPS Output Voltage		2.9		5.0	V
R <sub>VBUS</sub>	Internal Ideal Diode On Resistance	PIN to PIN, VBUS to IPSOUT			300	mΩ
<b>Battery Charger</b>						
V <sub>TRGT</sub>	BAT Charge Target Voltage		-0.5%	4.2	+0.5%	V
I <sub>CHRG</sub>	Charge Current			1200	1800	mA
I <sub>TRKL</sub>	Trickle Charge Current			10%		I <sub>CHRG</sub> mA
V <sub>TRKL</sub>	Trickle Charge Threshold Voltage			3.0		V

$\Delta V_{RECHG}$	Recharge Battery Threshold Voltage	Threshold Voltage Relative to $V_{TARGET}$		-100			mV
$T_{TIMER1}$	Charger Safety Timer Termination Time	Trickle Mode		40			Min
$T_{TIMER2}$	Charger Safety Timer Termination Time	CC Mode		480			Min
$I_{END}$	End of Charge Indication Current Ratio	CV Mode		10%	15%		$I_{CHRG}$ mA
<b>Backup Battery</b>							
$V_{TRGT}$	Backup Battery Charge Target Voltage			2.5	3.0	3.1	V
$I_{CHRG}$	Backup Battery Charge Current			50	200	400	uA
$I_{Backup}$	Current when use Backup Battery				10	15	uA
<b>NTC</b>							
$V_{TL}$	Cold Temperature Fault Threshold Voltage	Charge	0	2.112	3.264		V
		Discharge		3.226			
$V_{TH}$	Hot Temperature Fault Threshold Voltage	Charge	0	0.397	3.264		V
		Discharge		0.282			
$V_{TE}$	NTC Disable Threshold Voltage	Falling Threshold Hysteresis		0.2			V
<b>Ideal Diode</b>							
$R_{ds(on)}$	On Resistance(BAT to IPSOUT)					75	m $\Omega$

SYMBOL	DESCRIPTION	CONDITIONS	MIN	TYP	MAX	UNITS
<b>Off Mode Current</b>						
$I_{BATOFF}$	OFF Mode Current	BAT=3.8V		27		$\mu$ A
$I_{SUSPEND}$	USB VBUS suspend Mode current	BAT=3.8V, VBUS=5V, N_VBUSEN=1		86		$\mu$ A
<b>Logic</b>						
$V_{IL}$	Logic Low Input Voltage			0.3		V
$V_{IH}$	Logic High Input Voltage			2		V
<b>TWSI</b>						
$V_{CC}$	Input Supply Voltage			3.3		V
ADDRES S	TWSI Address			0x68		
$f_{SCK}$	Clock Operating Frequency			400	1200	KHZ
$t_f$	Clock Data Fall Time	2.2Kohm Pull High		60		ns

$t_r$	Clock Data Rise Time	2.2Kohm Pull High		100		ns
<b>DCDC</b>						
$f_{OSC}$	Oscillator Frequency	Default		1.5		MHz
<b>DCDC2</b>						
$I_{LIM2}$	PMOS Switch Current Limit	PWM Mode		2300		mA
$I_{DC2OUT}$	Available Output Current	PWM Mode			1800	mA
$V_{DC2OUT}$	Output Voltage Range		0.7		2.275	V
<b>DCDC3</b>						
$I_{LIM3}$	PMOS Switch Current Limit	PWM Mode		1400		mA
$I_{DC3OUT}$	Available Output Current	PWM Mode			1000	mA
$V_{DC3OUT}$	Output Voltage Range		0.7		3.5	V

SYMBOL	DESCRIPTION	CONDITIONS	MIN	TYP	MAX	UNITS
<b>LDO1</b>						
$V_{LDO1}$	Output Voltage	$I_{LDO1}=1mA$	-1%	1.3 3.3	1%	V
$I_{LDO1}$	Output Current			30		mA
<b>LDO2</b>						
$V_{LDO2}$	Output Voltage	$I_{LDO2}=1mA$	1.8		3.3	V
$I_{LDO2}$	Output Current			200		mA
PSRR	Power Supply Rejection Ratio	$I_{LDO2}=60mA, 1KHz$		TBD		dB
$e_N$	Output Noise,20-80KHz	$V_o=3V, I_o=150mA$		28		$\mu V_{RMS}$
<b>LDO3</b>						
$V_{LDO3}$	Output Voltage	$I_{LDO3}=1mA$	0.7		3.5	V
$I_{LDO3}$	Output Current			200		mA
PSRR	Power Supply Rejection Ratio	$I_{LDO3}=10mA, 1KHz$		TBD		dB
$e_N$	Output Noise,20-80KHz	$V_o=1.8V, I_o=150mA$		TBD		$\mu V_{RMS}$
<b>LDO4</b>						
$V_{LDO4}$	Output Voltage	$I_{LDO4}=1mA$	1.8		3.3	V
$I_{LDO4}$	Output Current			200		mA
PSRR	Power Supply Rejection Ratio	$I_{LDO4}=10mA, 1KHz$		TBD		dB
$e_N$	Output Noise,20-80KHz	$V_o=1.8V, I_o=150mA$		18		$\mu V_{RMS}$
<b>LDO5</b>						
$V_{LDO5}$	Output Voltage	$I_{LDO5}=1mA$	1.5		3.3	V
$I_{LDO5}$	Output Current			50		mA
PSRR	Power Supply Rejection Ratio	$I_{LDO5}=10mA, 1KHz$		TBD		dB
$e_N$	Output Noise,20-80KHz	$V_o=1.8V, I_o=30mA$		18		$\mu V_{RMS}$

## 6 . Typical Characteristics

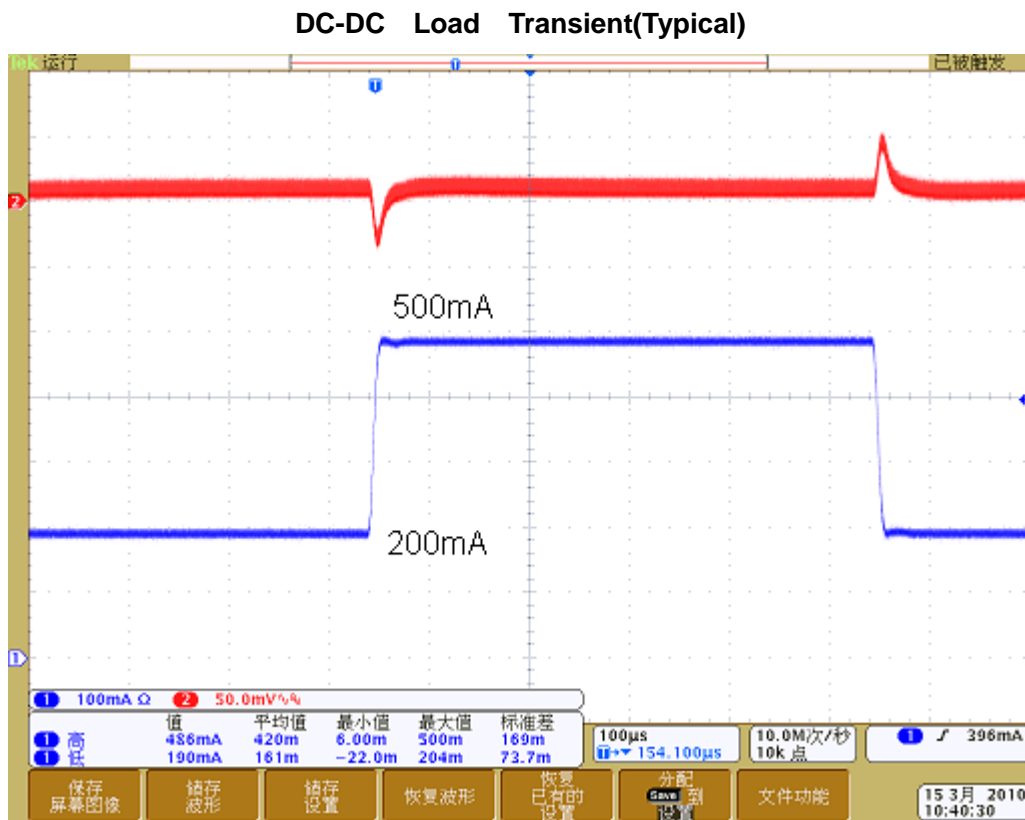
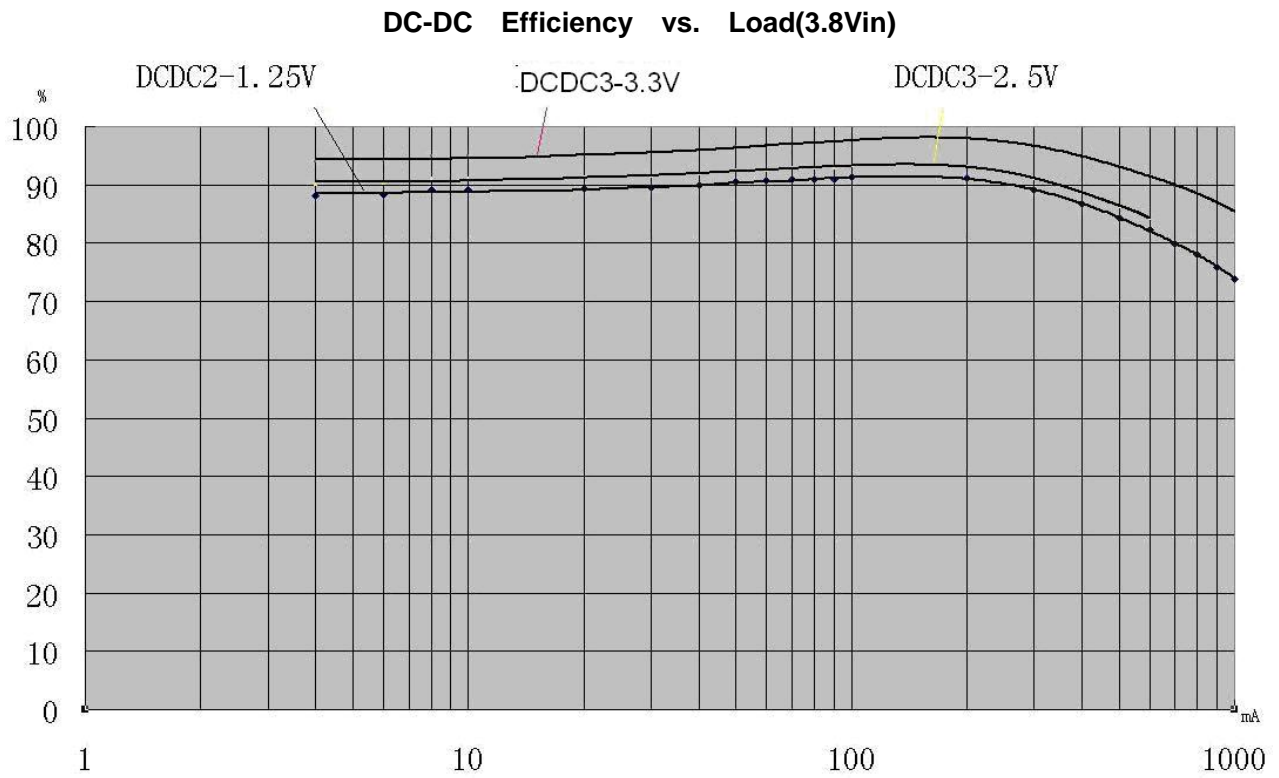



DC-DC Ripple

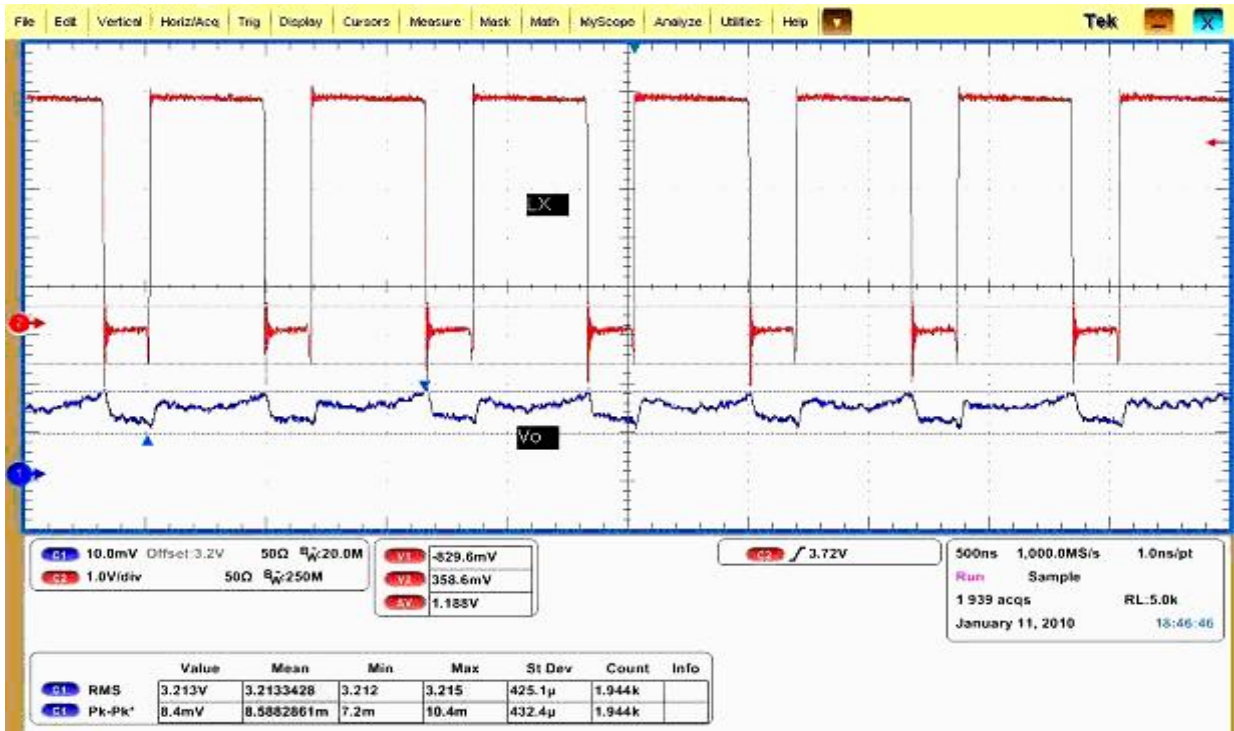

V<sub>REF</sub> vs Temperature

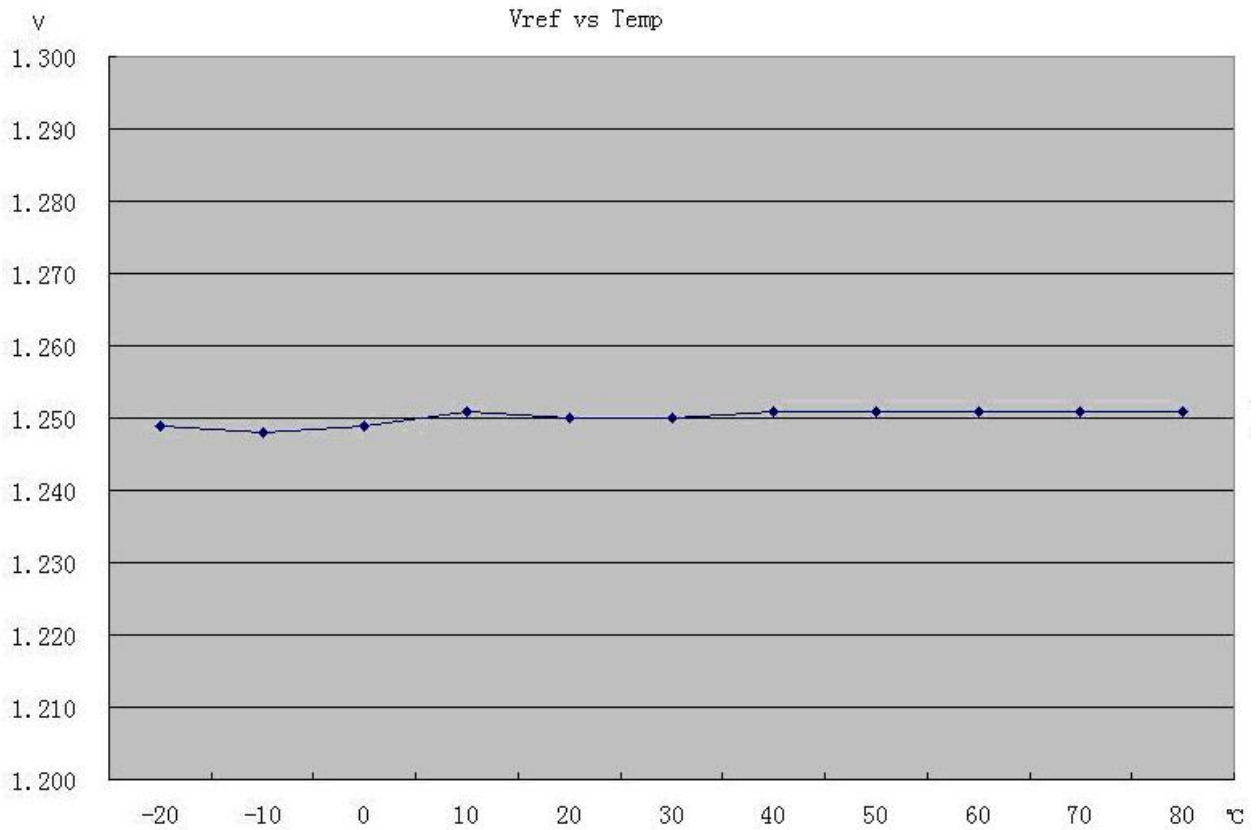

**V<sub>TRGT</sub> vs Temperature**

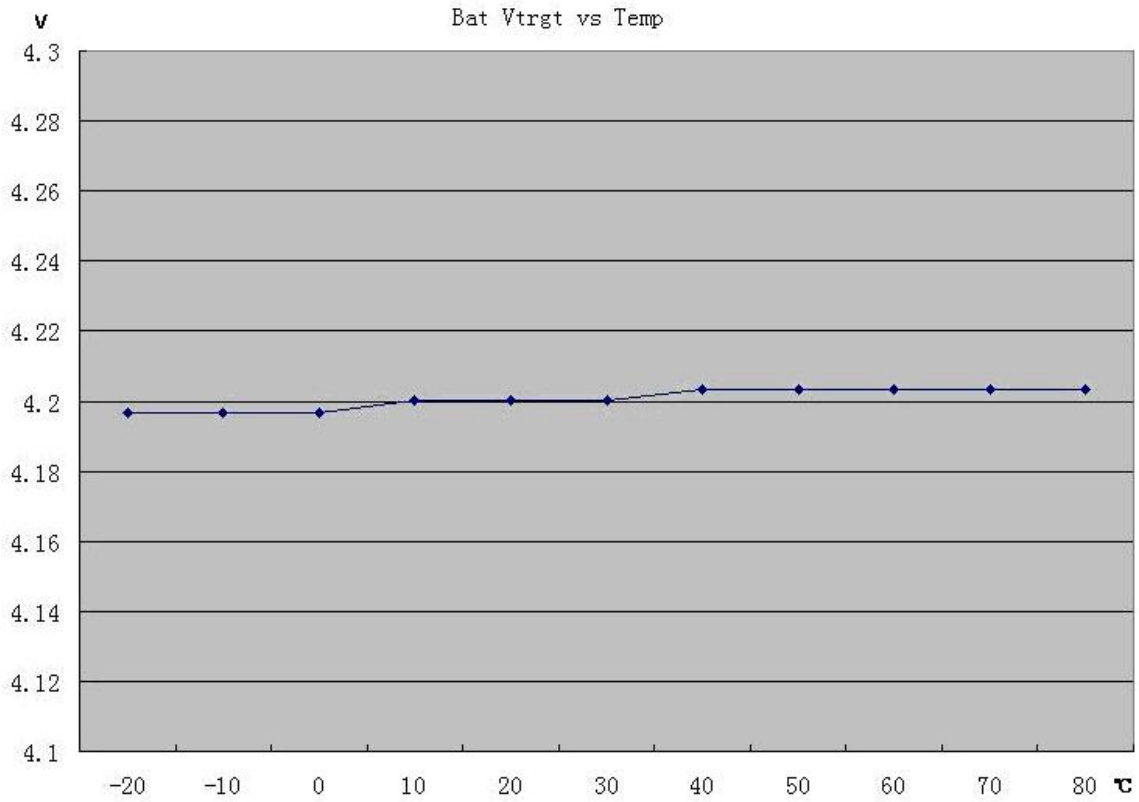

**Off Mode Current vs V<sub>BAT</sub>**

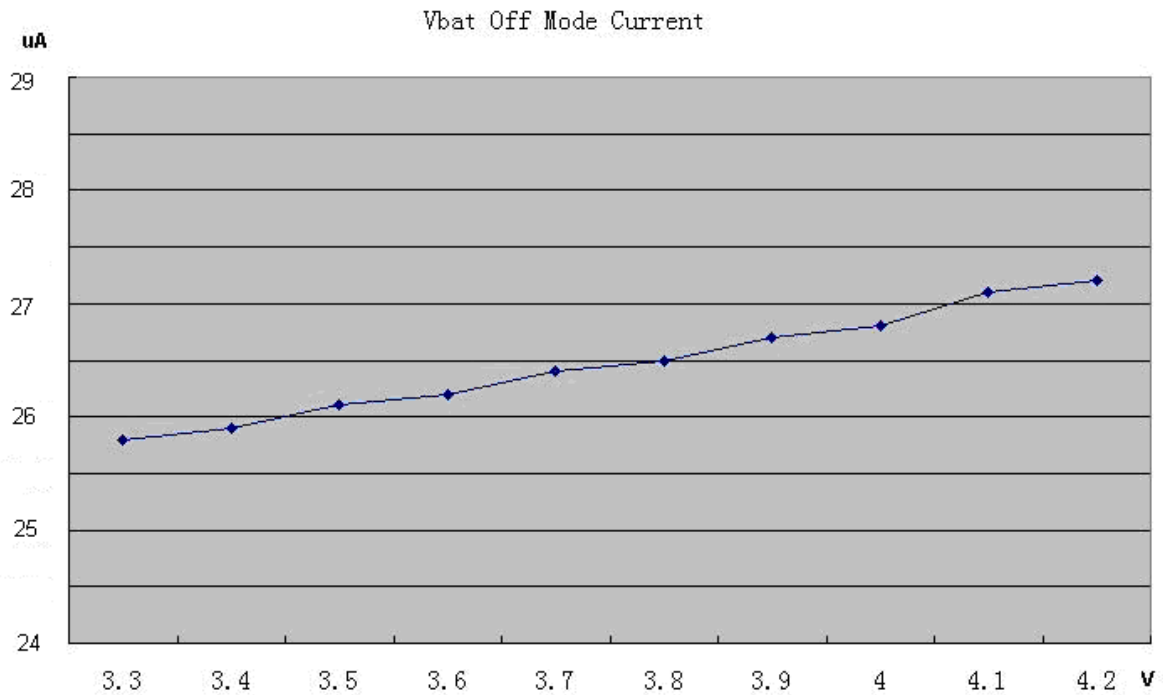

## 7 . Pin Description

Num	Name	Type	Condition	Function Description
1	SDA	IO		Data pin for serial interface, normally it connects a 2.2K resistor to 3.3V I/O power
2	SCK	I		the Clock pin for serial interface, normally it connects a 2.2K resistor to 3.3V I/O power
3	GPIO3	IO	REG9EH[7]	GPIO 3
4	N_OE	I		Power output on/off switch GND:on; IPSOUT:off
5	GPIO2	IO	REG92H[2:0]	GPIO 2
6	N_VBUSEN	I		VBUS to IPSOUT Selection GND:IPSOUT select VBUS High:IPSOUT do not select VBUS
7	VIN2	PI		DCDC2 input source
8	LX2	IO		Inductor Pin for DCDC2
9	PGND2	G		NMOS Ground for DCDC2
10	DCDC2	I		DC-DC2 feedback pin
11	LDO4	O		Output Pin of LDO4
12	LDO2	O		Output Pin of LDO2
13	LDO24IN	PI		Input to LDO2 and LDO4
14	VIN3	PI		DCDC3 input source
15	LX3	IO		Inductor Pin for DCDC3
16	PGND3	G		NMOS GND for DCDC3
17	DCDC3	I		Feed back to DCDC3
18	GPIO1	IO	REG93H[2:0]	GPIO 1 ADC Input
19	GPIO0	IO	REG90H[2:0]	GPIO 0 Low noise LDO/Switch ADC Input
20	EXTEN	O		External Power Enable
21	APS	PI		Internal Power Input
22	AGND	G		Analog Ground
23	BIAS	IO		External 200Kohm 1% resistor
24	VREF	O		Internal reference voltage
25	PWROK	O		Power Good Indication Output
26	VINT	PO		Internal logic power, 2.5V
27	PWREN	IO		It is the Power domain enable signal
28	LDO1	O		LDO1 output, for Host RTC block

29	DC3SET	IO		It set the DCDC3 default voltage
30	BACKUP	IO		Backup battery pin
31	VBUS	PI		USB VBUS input
32, 33	ACIN	PI		Adapter input
34, 35	IPSOUT	IO		Main Battery
36	CHGLED	O		Charger status indication
37	TS	I		Battery Temperature sensor input or external ADC input
38, 39	BAT	PO		System power source
40	LDO3IN	O		LDO3 input source
41	LDO3	I		Output Pin of LDO3
42	BATSENSE	I		PWM Charger Current sense port1
43	CHSENSE	O		PWM Charger Current sense port2
44	VIN1	PI		PWM Charger input source
45	LX1	IO		Inductor Pin for PWM Charger
46	PGND1	G		NMOS Ground for PWM Charger
47	PWRON	I		Power On-Off key input
48	IRQ	IO		IRQ output
49	EP	G		Exposed Pad, need to connect to system ground

## 8 . Functional Block Diagram

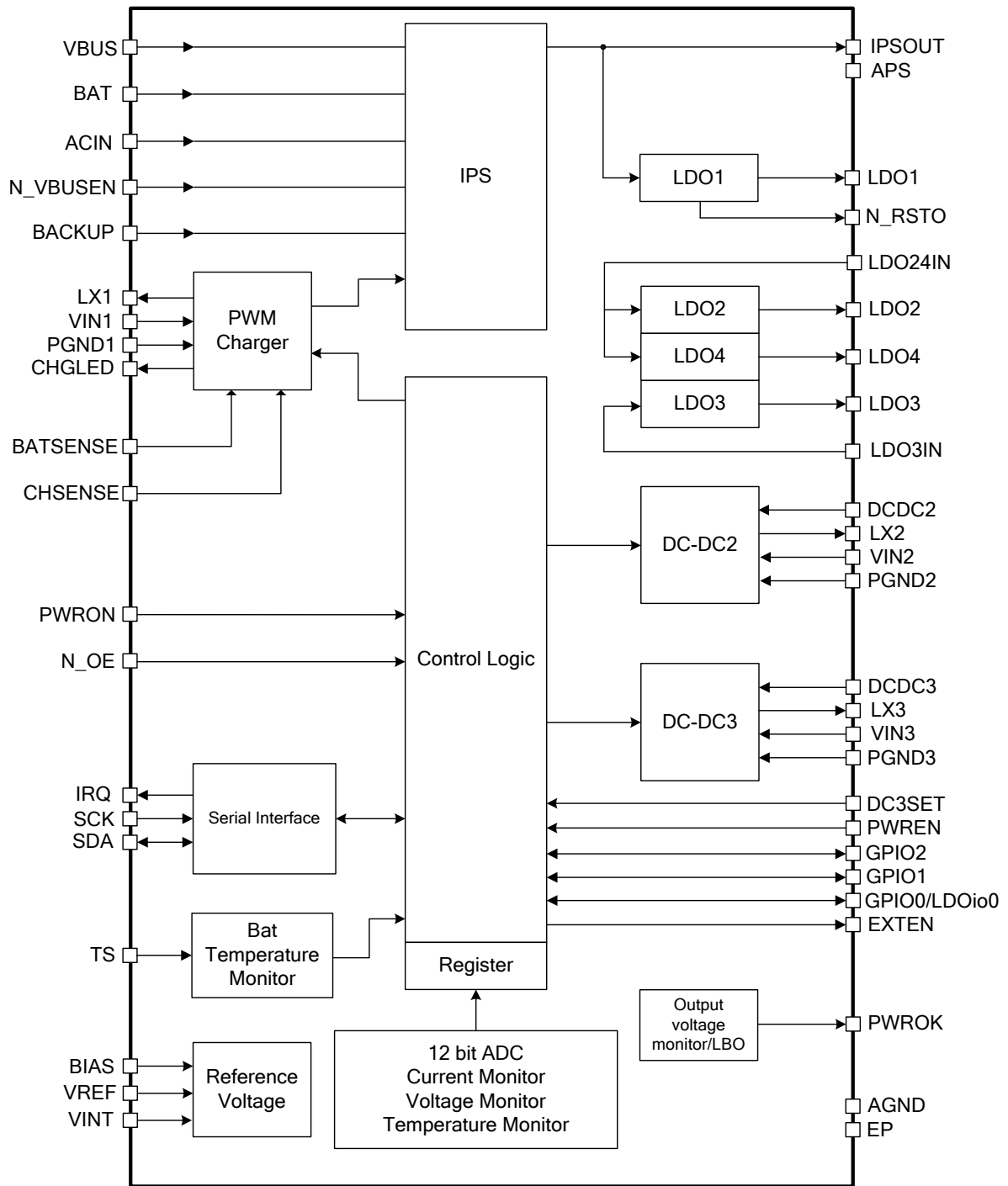

## 9 . Control and Operation

Once AXP202 is powered on, SCK/SDA pin of TWI will be pulled up to IO Power and then Host can adjust and monitor AXP202.

Remarks: "Host" here refers to system processor.

Remarks: "External Power" below includes ACIN and VBUS input.

### 9.1 Power On/Off & Reset

#### Power Enable Key (PEK)

The Power Enable/ Sleep/Wakeup Key can be connected between PWRON pin and GND of AXP202. AXP202 can automatically identify the "Long-press" and "Short-press" and then correspond respectively.

#### Power on Source

1. ACIN、VBUS and battery
2. N\_OE changes from high to low
3. PEK

#### Power On

System power-on is initiated whenever the following conditions occur:

1. N\_OE is low and a valid power source has plugged in (ACIN or VBUS>3.8V, and battery voltage is higher than power off voltage), AXP202 will be turned on. ( Developer can decide whether AXP202 shall be turned on when there is a valid power source plugging in)
2. N\_OE is low and the system is powered off, press PEK can power on AXP202 (In application, Host Alarm output signal can be connected to PWRON and parallel with PEK. Whenever there is a valid Alarm signal ((Low Level)), AXP202 can be powered on).
3. When there is a external power source or battery, when N\_OE changes from high to low, AXP202 will be turned on.

After power on, DC-DC and LDO will be soft booted in preset timing sequence, and then either Host or PWREN pin can enable/disable corresponding power.

## Power Off

When you push-and-hold PEK longer than IRQLEVEL, HOST can write “1” into “REG32H [7]” to inform AXP202 to shutdown, which can disable all power output except LDO1.

System power-off is initiated whenever the following conditions occur:

1. input voltage is too low( Low-Power Protection)
2. Power output voltage is too low due to overload( Overload Protection)
3. Input voltage is too high( Overvoltage Protection)( See more details in chapter “ Intelligent Power Select”
4. Have waited more than 2S(default) when N\_OE changes from hight to low
5. Push PEK longer more than OFFLEVEL( Default 6S), and system will cut off all power output except LDO1( there is no need for an extra RESET key)

Remarks: With the automatic protection mechanism, AXP202 can protect whole system by preventing Components from irriversable damage due to system abnormality.

## Sleep and wakeup

When the running system needs to enter Sleep mode, REG31H [3] will determine whether one or several power rails should be disabled or change to other voltage. Wakeup can be triggered by either PEK signal, or the rising/falling edge of GPIO0、GPIO1、GPIO2、GPIO3 (To be the rising or falling edge, or both can be programmed by REG90H[7:6]、REG92H[7:6]、REG93H[7:6] and REG95H[7:6]), with all power rails resume to default voltage in default power on timing sequence.

NOTE: PEK IRQ (REG42H[1])、GPIO0 INPUT Edge IRQ (REG44H[0])、GPIO1 INPUT Edge IRQ (REG44H[1])、GPIO2 INPUT Edge IRQ (REG44H[2])、GPIO3 INPUT Edge IR (REG44H[3]) should be “Enable” to notify the processor to exit Sleep Mode via IRQ PIN.

See control process under sleep and wakeup modes as below:

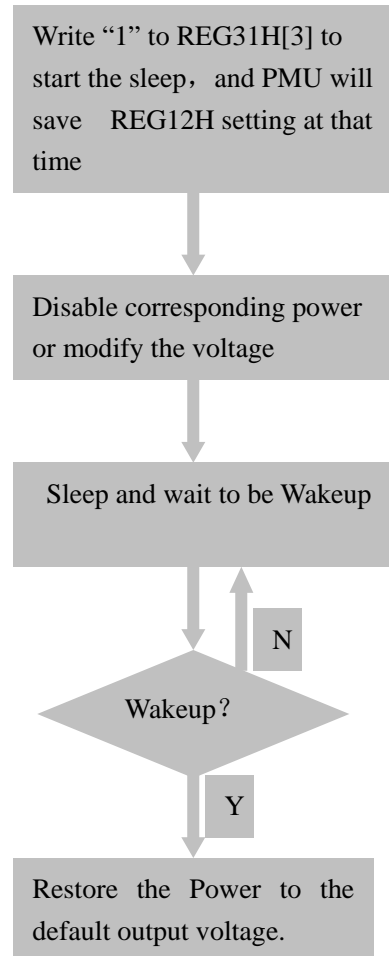

### System Reset and Output Monitoring (PWROK)

The PWROK in AXP202 can be used as the reset signal of application system. During AXP202 startup, PWROK outputs low level, which will then be pulled high to startup and reset the system after each output voltage reaches the regulated value.

When application system works normally, AXP202 will be always monitoring the voltage and load status. If overload or under-voltage occurs, the PWROK will instantly drive low to reset the system and prevent data losses.

### 9.2 Power Path Management (IPS)

Power input of AXP202 may come from Li-battery, USB VBUS input, external power ACIN (such as AC adapter). IPS can select proper power according to external power and Li-battery status.

- If only Li-battery is available, and no external power input, Li-battery is used for power input;
- If external power is available (VBUS or ACIN), it is preferred in power supply



- If Li-battery is available, it will “Seamlessly” switch to Li-battery once external power is removed
- When both VBUS and ACIN are available, ACIN will be applied to supply power in priority, and Li-battery will be charged.
- If ACIN drive capability is not enough, VBUS will be enabled to achieve ACIN/VBUS common power supply.
- If the drive capacity is still insufficient, charge current will be reduced to zero, and battery is used for power supply.

Therefore, compatibility of the system with external powers of different drive ability can be dramatically improved, and no special customized adapters are required to be provided on the part of manufacturers.

Please refer to the following diagram.

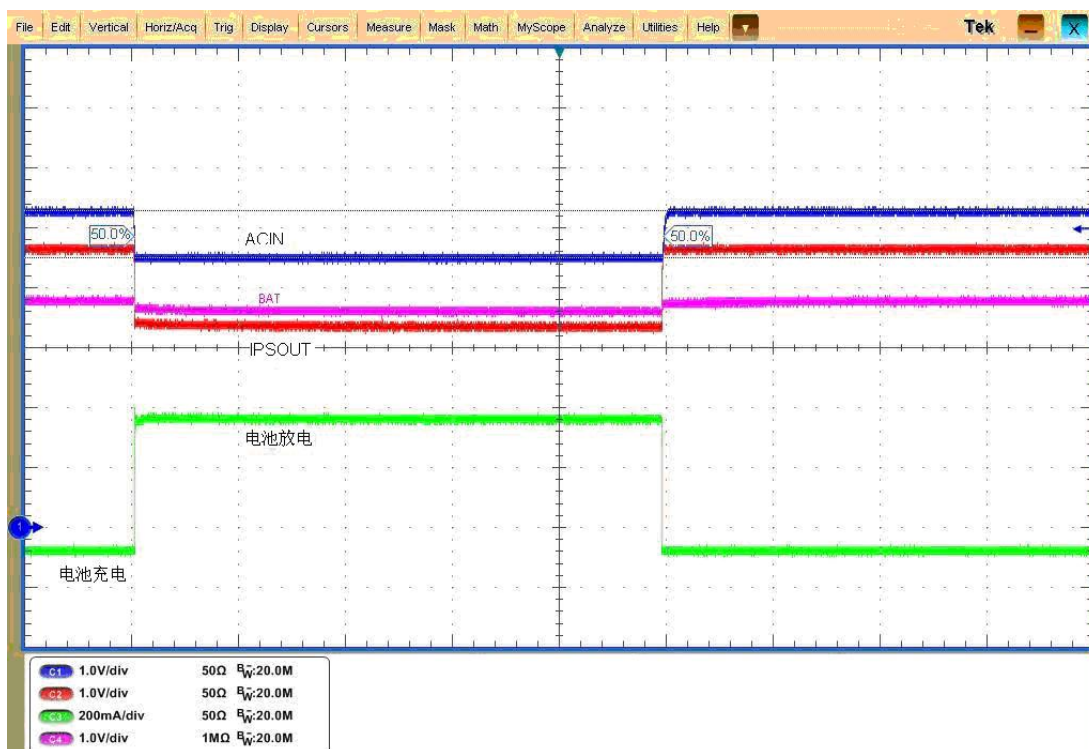

As shown above, when ACIN provides insufficient load ability, IPSOUT voltage will fall, and BAT will change from charge to discharge to supply load current together with ACIN.

Host can set IPS parameters and read the feedback by visiting internal registers in AXP202 via TWSI.

### Voltage-Limit/ Current-Limit Mode and Direct Mode

In order not to affect the USB communication, VBUS is always working under Voltage-Limit mode by default. In this mode, AXP202 ensures that VBUS voltage remains above a configurable reference voltage VHOLD which can meet the USB specification. The default VHOLD is 4.4V, adjustable in Reg30H [5:3] register.

If the system has limit on current obtained from USB VBUS, a current-limit mode is provided (See REG30H[1] register), with 900mA/500mA/100mA (Reg30H [0]) selectable.

If the system just utilizes the USB for power supply rather than communication, or the USB power adapter is utilized, AXP202 can be set to “VBUS Direct Mode” by modifying register REG30H[6], and then AXP202 will give priority to the application power demand. When the drive ability of USB Host is insufficient or system power consumption is large then the VBUS voltage is lower than VHOLD, AXP202 will release IRQ to indicate the weak power supply ability of Host VBUS, which may affect USB communication, and then Host software will follow up.

### AXP202’s Reaction to External Power Supply Plugin

AXP202 can automatically detect the plugin of external powersand judge whether the power is usable or not. The result will be set in corresponding registers, and IRQ will be released to inform the Host at the same time.

The following table has listed the status bits and meanings of external power registers.

Register Status Bits	Description
REG00H[7]	Indicating the presence of external ACIN
REG00H[6]	Indicating whether the external ACIN is usable or not
REG00H[5]	Indicating the presence of external VBUS
REG00H[4]	Indicating whether the external VBUS is usable or not
REG00H[3]	Indicating whether the VBUS voltage is above $V_{HOLD}$ when used
REG00H[1]	Indicating whether ACIN/VBUS short circuits on PCB or not
REG00H[0]	Indicating whether the system is triggered to startup by ACIN/VBUS or not

The status bit of “indicating whether the VBUS voltage is above  $V_{HOLD}$  or not when used” enables the Host to judge when it receives IRQ7(indicating weak supply ability)whether VBUS is pulled low by system load input or the external power itself is below  $V_{HOLD}$ , which may facilitate Host software to decide either to keep on working in Voltage-Limit mode or switch to Direct mode.

### When to Select VBUS as Input Power

N\_VBUSEN and register REG30H[7]: is used to determined when shall VBUS be used as power

supply.

N_VBUSEN	REG30H[7]	Input Power	Description
Low	0	VBUS	Select if VBUS is valid and no ACIN is available
Low	1	VBUS	select if VBUS is valid
High	1	VBUS	
High	0	ACIN/BAT	Not select VBUS

### Low-Power Warning and Low-Power Protection (Automatic Poweroff)

With AXP202, the value of  $V_{\text{WARNING}}$ (low-power warning voltage) and  $V_{\text{OFF}}$ (automatic shutdown voltage) can be set. If the system power is found to be lower than  $V_{\text{WARNING}}$ , IRQ19/IRQ20 will be released. If APS is lower than  $V_{\text{OFF}}$ , AXP202 will automatically enter Shutdown Mode, and disable all other outputs except LDO1.

There are two-levels in  $V_{\text{WARNING}}$ , namely, LEVEL 1 and LEVEL 2, which can be defined differently in applications. For example, use LEVEL1 to indicate insufficient power while LEVEL 2 can be used to indicate the oncoming shutdown.

The default values of  $V_{\text{WARNING}}$  and  $V_{\text{OFF}}$  can be respectively set in registers REG3AH、REG3BH and REG31H[2:0].

### Over-Voltage Protection

If the external power voltage exceeds 6.3V, AXP202 will release IRQ1/4 for indication. If the external power voltage exceeds 7V, AXP202 will automatically shutdown the system.

## 9.3 Adaptive PWM Charger

AXP202 integrates a constant current/voltage PWM charger to automatically control the charge cycle, with a built-in safety clock capable of automatic charge termination without processor intervention. This charger features automatic charge current scaling in accordance with the system power consumption, as well as battery detection, trickle charge and activation. In addition, the built-in temperature detection circuit can automatically decrease the charge current when the temperature is too high or too low.

Compared with traditional linear charge, this PWM charger features dramatic efficiency increase and power consumption decrease in systems that require large power consumption and fast battery charging, and thus greatly improve the system temperature performance.

### Adaptive Charge Startup

The default state of the charger is “Enable”. (It can be programmed via registers. Refer to register REG33H.) When external power is plugged in, AXP202 will firstly judge whether it is chargeable. If the charger is suitable for the power, and the charge function is usable, AXP202 will automatically start the charge, and send IRQ to Host for indication. At the same time, GHGLED pin will output low level to drive external LED to indicate the charging state.

### Charge Voltage/Current:

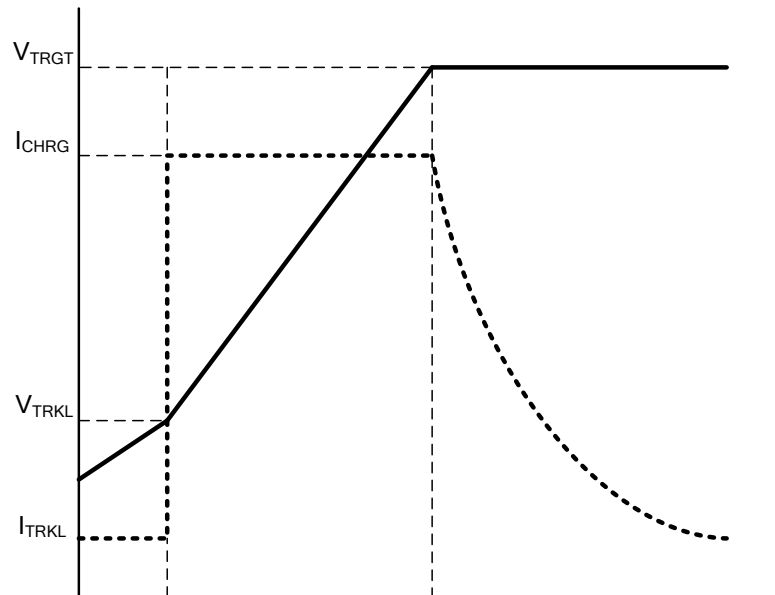

### Two Symbolic Voltages

$V_{TRGT}$ =charge target voltage. The  $V_{TRGT}$  is 4.2V by default, which can be set by register (Refer to “REG33H[6:5]”). At the same time, AXP202 will automatically adjust the charge target voltage when external power voltage is low.

$V_{RCH}$ =automatic recharge voltage.  $V_{RCH}=V_{TRGT}-0.1V$ .

### Charge Current

The charge current is 500mA or 1200mA by default, which can be set by REG33H [3:0].

### Charge Process

If the battery voltage is lower than 3.0V, the charger will automatically enter the pre-charge mode, with charge current be 1/10 of the preset value. If the battery voltage is still below 3.0V 40 minutes later (adjustable, see “REG34H”), charger will automatically enter the battery activate mode. Refer to “Battery Activate Mode” section for details.

Once the battery voltage exceeds 3.0V, the charger enters constant current mode. If the charge current is below 65% of the preset value, the system will release IRQ17 to indicate that “drive ability of external power is insufficient, as a result, the charge current is lower than the preset value, which may lead to longer charge time, so stronger power is preferred, or the power-consuming functions should be disabled to shorten the charge time.”

When the battery voltage reaches the  $V_{TRGT}$ , the charger will switch from the constant current mode to constant voltage mode, and the charge current will fall.

When the charge current is lower than 10% or 15% (adjustable, see register “REG33H”) of the preset value, a charge cycle ends, and AXP202 will release IRQ18 while the CHGLED pin will stop indicating the charging state. When the battery voltage is below  $V_{RCH}$  again, the automatic charge will restart, and IRQ17 will be released.

In non-precharge mode, if the charge cycle is not ending after 480 minutes (adjustable, refer to register “REG34H”), the charger will automatically enter the battery activate mode.

### Battery Activate Mode

At the entering the battery activate mode from either pre-charge mode or constant current mod(the timer expires), AXP202 will release IRQ10 in both cases to indicate that the battery may be damaged.

In battery activate mode, the charger always inputs relatively low current to batteries. AXP202 will exit activate mode and release IRQ11 only if the battery voltage has reached  $V_{RCH}$ .

AXP202 will indicate whether the charger is in battery activate mode or not in register REG01H.

### CHGLED

CHGLED pin is used to indicate charge state and warning. There are four states, namely, charging, not charging, battery abnormal warning, and external power over-voltage warning. CHGLED is NMOS Open Drain output, so a LED can be directly driven by a current-limit resistor to show the four states. The following table has displayed its two operation modes.

REG34H[4]	Status	Performance	Remark
0	Charging	Low Level	
	Not charging	High Resistance	
	Battery Abnormal	1Hz flicker	The charger enters the battery activate mode, or the battery temperature is too high/low.
	Over-Voltage	4Hz flicker	External voltage input is too high.
1	Charging	1Hz flicker	
	Non-chargeable	High	No external power is available.

		Resistance	
	Not charging	Low Level	
	Over-Voltage	4Hz Flicker	External voltage input is too high, or the battery temperature is too high/low.

### Battery Temperature Detection

AXP202 can connect a temperature-sensitive resistor via the TS pin to monitor the battery temperature when the battery is charging or discharging. The diagram is shown below.

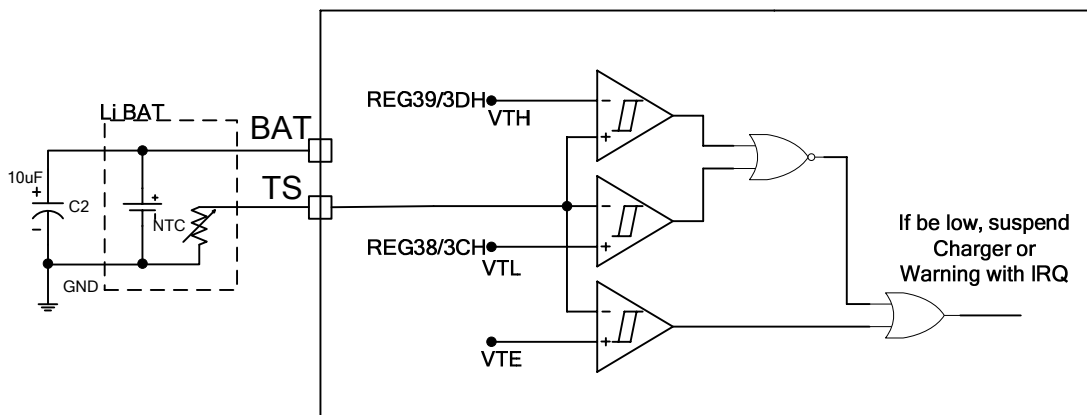

In the diagram above, VTH/VTL refer to the high temperature threshold and low temperature threshold, which is programmable via registers REG38H/39H/3CH/3DH respectively. VTE=0.2V. The temperature-sensitive resistor is suggested to choose the NTC temperature-sensitive resistor, which is 10Kohm and 1% accuracy at 25°C. AXP202 will send constant current via TS pin, and the current can be set as 20uA, 40uA, 60uA, and 80uA (See register REG84H) to adapt to different NTC resistors. When the current goes through the temperature-sensitive resistor, a test voltage is generated, which will be measured by ADC, and compared with regulated value to release corresponding IRQ or suspend the charge.

If the resistance value of temperature-sensitive resistor is too high or too low, extra resistors can be serial or parallel connected to expand the detect extent.

If the battery is free from temperature-sensitive resistor, TS pin can be linked to the ground, and in that case, AXP202 will automatically disable the battery temperature monitoring function.

### Battery Detection

AXP202 will automatically detect the battery presence, record the result in registers (refer to REG01H) and release IRQ13, IRQ14.

The battery detection can be enabled and disabled by Host. (Refer to register REG32H.)

### 9.4 Backup Batttery

AXP202 supports backup battery charge and discharge. When no main power (BAT/ACIN/VBUS) is available, LDO1 will choose the backup battery to support the operation of some circuits, such as the system real-time clock, etc.

When there is a main power, REG35H[7] can be set to charge the backup battery, whose target voltage is 3.0V by default (adjustable via REG35H[6:5]) and charge current is 200uA by default (adjustable via REG35H[1:0]).

### 9.5 Multi-Power Outputs

The following table has listed the multi-power outputs and their functions of AXP202.

Output Path	Type	Default Voltage	Application Examples	Drive Ability
DCDC2	BUCK	Configurable	1.25Vcore	1800 mA
DCDC3	BUCK	Configurable	2.5Vddr	1000 mA
LDO1	LDO	Configurable	RTC	30 mA
LDO2	LDO	Configurable	Analog/FM	200 mA
LDO3	LDO	Configurable	1.3V PLL	200 mA
LDO4	LDO	Configurable	1.8V HDMI	200 mA
LDO5	LDO	Configurable	Vmic	50 mA

AXP202 comes with two synchronous step-down DC-DCs, five LDOs, as well as multiple timing and controlling methods. The work frequency of DC-DC is 1.5MHz by default, which is adjustable via registers. External small inductors and capacitors can be connected as well. In addition, both DC-DCs can be set in PWM mode or auto mode (automatically switchable according to the AXP202 load). See register REG80H.

#### DC-DC2/3

DCDC3 output voltage ranges from 0.7 V to 3.5V, and output voltage of DCDC2 is ranged from 0.7-2.275V, which can be programmed via registers.(refer to “ register REG23H 27H”).

DCDC2/3 output capacitor is recommended to use small ESR ceramic capacitors above 10uF X7R;

when the output voltage is set above 2.5V, 2.2uH inductors is recommended; when the output voltage is set under 2.5V, 4.7uH inductors is recommended. Besides, the inductor saturation current should be larger than 50% of the largest demanded current in power circuitry.

Inductor Recommendation List:

<b>Inductors</b>		
<b>Module NO.</b>	<b>Current Spec</b>	<b>DC Internal Resistance</b>
Murata LQH55PN2R2NR0	2100mA@2.2uH	30mOhm
Murata LQH55PN4R7NR0	1400mA@4.7uH	60mOhm
Murata LQH44PN2R2MP0	2000mA@2.2uH	49mOhm
Murata LQH44PN4R7MP0	1700mA@2.2uH	80mOhm
TDK VLF5010ST-2R2M2R3	2700mA@2.2uH	41mOhm
TDK VLF5014ST-4R7M1R7	1700mA@4.7uH	98mOhm
TDK SLF6045T-4R7N2R4-3PF	2400mA@4.7uH	27mOhm
<b>Capacitors</b>		
<b>Module NO.</b>	<b>Temperature spec</b>	<b>Allowance</b>
TDK C2012X5R0J475K	X5R/X7R	10%@4.7uF
TDK C2012X5R0J106K	X5R/X7R	10%@10uF
Murata GRM31E71A475K	X7R	10%@4.7uF
Murata GRM21E71A106K	X7R	10%@10uF
Murata GRM31E71A106K	X7R	10%@10uF

### LDO 1

LDO1 is always on and can be used to supply continuous power for application RTC with 30mA drive ability 30mA.

### LDO2/3/4

LDO2/4 output noise is as low as 18uVrms, and can be used to supply power for analog circuits of application system. LDO3 can supply power for systems like SRAM or PLL with 200mA drive ability.

### LDO5

LDO5 also features the low noise design, and its drive ability is 50mA.

### Soft Start

All DC-DCs and LDOs support soft start which can avoid the impact of dramatic current change on the input path in system boot stage.

### Self-Diagnosis: Load Monitoring and Current-Limit Protection



All DC-DCs and LDOs support load monitoring and current-limit functions. When the load current exceeds its drive ability, all output voltage will decrease to protect the internal circuits. When the two DC-DCs output voltage is lower than 85% of the set voltage, AXP202 will automatically shutdown. At the same time, the system will record the detailed output voltage that has lead to automatic shutdown (refer to register REG46H[5:2]) and release corresponding IRQ.

All DC-DCs do not require external Schottky diodes and resistor divider feedback circuits. If a certain DC-DC is unnecessary in application, just float the corresponding LX pins.

### 9.6 Default Voltage/Timing Setting

The default voltage and boot timing of each power can be set by AXP202.

Boot Timing includes eight levels, and the interval between each level can be set as 1、4、16 and 32mS.

Default voltage setting: each DC-DC/LDO setting ranges from the lowest voltage to the highest voltage.

#### DC3SET PIN is used to set the preliminary voltage of DC-DC3:

DC3SET	DC3SETGND	DC3SETto OAPS	DC3SET floating
DC-DC3 voltage	1.8V	3.3V/2.5V	1.2V/1.5V

### 9.7 Signal Capture

Ordinary battery monitor estimate the battery energy by measuring the battery voltage. However, the multiple 12-bit ADCs in AXP202 can measure battery voltage, as well as battery current and external power voltage and current. It also integrates battery charge and discharge coulomb counter. According to these data, Host is capable of calculating accurately the battery energy and other battery data, such as the system real-time consumption, remaining battery energy, battery charge progress, remaining battery using time and charge time, etc.

The Enable state controlling and sampling rate of each ADC can be set via registers REG82H、83H、84H. The sampling results will be saved in corresponding registers, and reference can be made to the ADC data in Register Instruction section. The input range of GPIO[1:0] can be set via register REG85H while register REG00H[2] is used to indicate the battery charge/discharge current directions.

Channel	000H	STEP	FFFH
Battery Voltage	0mV	1.1mV	4.5045V
Bat discharge current	0mA	0.5mA	4.095A

Bat charge current	0mA	0.5mA	4.095A
ACIN volatge	0mV	1.7mV	6.9615V
ACIN current	0mA	0.625mA	2.5594A
VBUS voltage	0mV	1.7mV	6.9615V
VBUS current	0mA	0.375mA	1.5356A
Internal temperature	-144.7°C	0.1°C	264.8°C
APS voltage	0mV	1.4mV	5.733V
TS pin input	0mV	0.8mV	3.276V
GPIO0	0/0.7V	0.5mV	2.0475/2.7475V
GPIO1	0/0.7V	0.5mV	2.0475/2.7475V

## 9.8 Multi-Function Pin Description

### GPIO[3:0]

Can be defined as GPIO[3:0], ADC Input (monitoring external signals) , or LDO, etc. Please refer to REG90H-96H Instruction for details

### CHGLED

Features charge state indication, over-temperature/over-voltage warning, and GPO. Please refer to REG32H Instruction section for details.

## 9.9 Timer

AXP202 features a 7-bit internal timer, whose values can be programmed via register REG8AH[6:0]. The minimum time step of timer is one minute, and the timing range is 1~127 minutes.

9.10 TWSI and IRQ

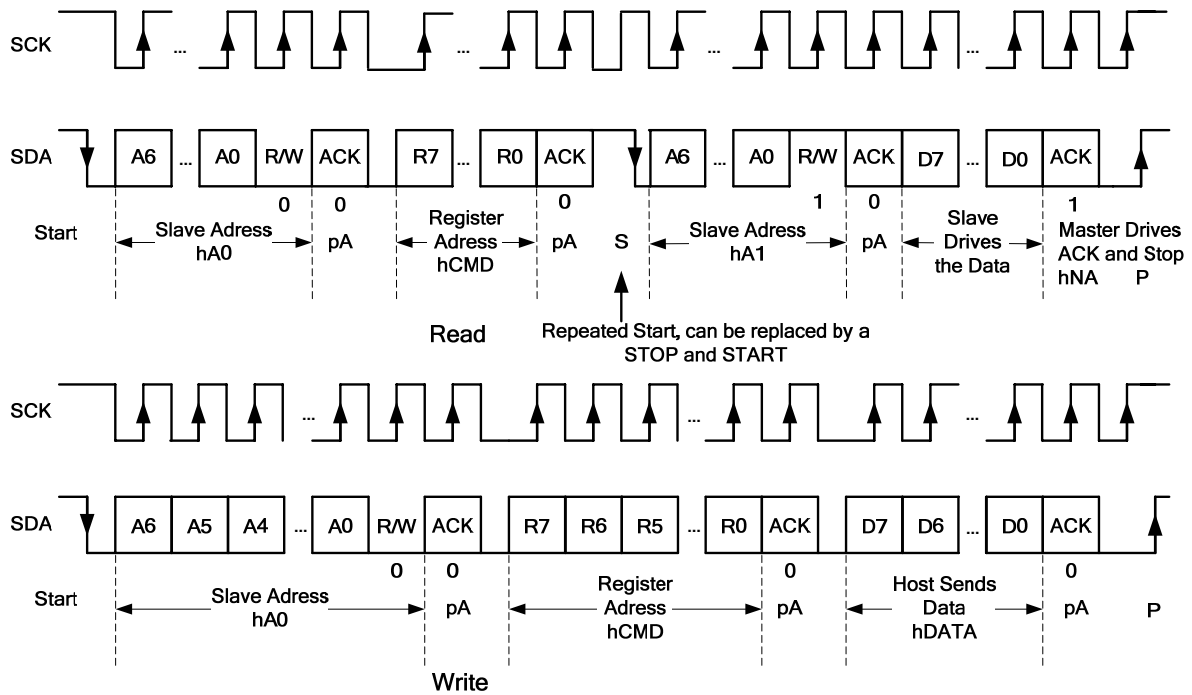

Fig.1: Single Read and Write

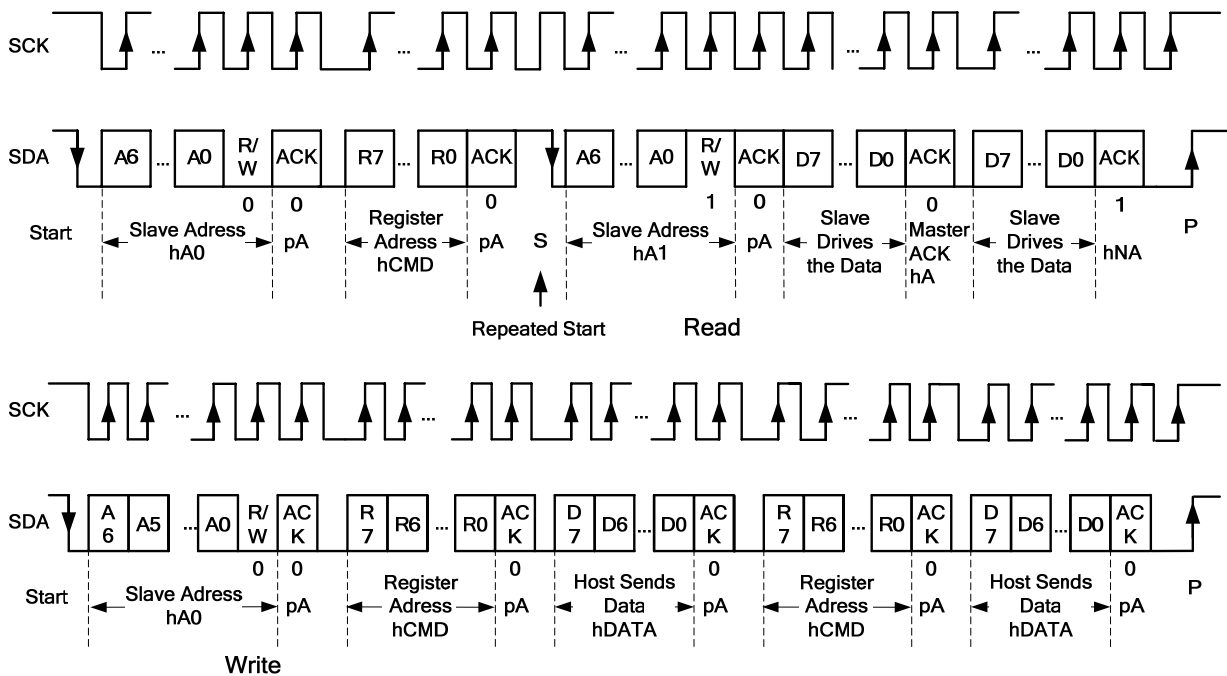

Fig.2: Multi Read and Write

Host can visit AXP202 registers via the TWSI interface, and the operation timing is listed above.

Standard 100KHz or 400KHz frequency is supported, and the highest rate can reach 1.2KHz. In addition, multi read and write operation is supported, and the device addresses are 69H (READ) and 68H (WRITE).

When certain events occur, AXP202 will inform Host by pulling down the IRQ interrupt mechanism, and the interrupt state will be reserved in interrupt state registers (See registers REG48H, REG49H, REG4AH, REG4BH and REG4CH). The interrupt can be cleared by writing 1 to corresponding state register bit. When there is no interrupt, IRQ output will be pulled high (51K resistance higher through the external). Each interrupt can be masked via interrupt control registers (Refer to registers REG40H, REG41H, REG42H, REG43H, and REG44H).

REG	IRQ	Description	REG	IRQ	Description
REG48H[7]	IRQ1	ACIN Over voltage	REG 4AH[3]	IRQ20	DCDC3 voltage too long
REG 48H[6]	IRQ2	ACIN plug in	REG 4AH[2]		Reserved
REG 48H[5]	IRQ3	ACIN removal	REG 4AH[1]	IRQ22	PEKshort-press
REG 48H[4]	IRQ4	VBUS Over voltage	REG 4AH[0]	IRQ23	PEK long-press
REG 48H[3]	IRQ5	VBUS plug in	REG 4BH[7]	IRQ24	N_OE Power on
REG 48H[2]	IRQ6	VBUS removal	REG 4BH[6]	IRQ25	N_OEPower off
REG 48H[1]	IRQ7	VBUS voltage lower than $V_{HOLD}$	REG 4BH[5]	IRQ26	VBUS Valid
REG 48H[0]		Reseverd	REG 4BH[4]	IRQ27	VBUS Invalid
REG 49H[7]	IRQ8	Battery plugin	REG 4BH[3]	IRQ28	VBUS Session Valid
REG 49H[6]	IRQ9	Battery Removal	REG 4BH[2]	IRQ29	VBUS Session End
REG 49H[5]	IRQ10	Enter battery activate mode	REG 4BH[1]	IRQ30	Low power LEVEL1
REG 49H[4]	IRQ11	Exit battery activate mode	REG 4BH[0]	IRQ31	Low power LEVEL2
REG 49H[3]	IRQ12	charging	REG 4CH[7]	IRQ32	Timer interrupt
REG 49H[2]	IRQ13	Charge Done	REG 4CH[6]	IRQ33	PEK rising edge
REG 49H[1]	IRQ14	Battery temp toor high	REG 4CH[5]	IRQ34	PEK falling edge
REG 49H[0]	IRQ15	Battery temp too low	REG 4CH[4]		Reserved
REG 4AH[7]	IRQ16	Die Temp too high	REG 4CH[3]	IRQ35	GPIO3 input edge trigger
REG 4AH[6]	IRQ17	Charge current insufficient	REG 4CH[2]	IRQ36	GPIO2 input edge trigger
REG 4AH[5]	IRQ18	DCDC1voltage too long	REG 4CH[1]	IRQ37	GPIO1 input edge trigger
REG 4AH[4]	IRQ19	DCDC2 voltage too long	REG 4CH[0]	IRQ38	GPIO0 input edge trigger

## 10. Registers

### Group 1: Power Control

Address	Register Description	R/W	Default Value
00	Power status register	R	
01	Power mode/ charge state register	R	
02	OTG VBUS state register	R	
04-0F	Data buffer register	R/W	00H
12	DC-DC2/3 & LDO2/3/4&EXTEN control register	R/W	XXH
23	DC-DC2 voltage setting register	R/W	XXH
25	DC-DC2/LDO3 voltage ramp parameter setting register	R/W	00H
27	DC-DC3 voltage setting register	R/W	XXH
28	LDO2/3 voltage setting register	R/W	XXH
30	VBUS-IPSOUT channel setting register	R/W	60H
31	V <sub>OFF</sub> shutdown voltage setting register	R/W	X3H
32	Shutdown, battery detection, CHGLED control register	R/W	46H
33	Charge control register1	R/W	CXH
34	Charge control register2	R/W	41H
35	Backup battery charge control register	R/W	22H
36	PEK parameter control register	R/W	5DH
37	DCDC converter work frequency setting register	R/W	08H
38	Battery charge under-temperature warning setting register	R/W	A5H
39	Battery charge over-temperature warning setting register	R/W	1FH
3A	APS low-power Level1 setting register	R/W	68H
3B	APS low-power Level2 setting register	R/W	5FH
3C	Battery discharge under-temperature warning setting register	R/W	FCH
3D	Battery discharge over-temperature warning setting register	R/W	16H
80	DCDC work mode setting register	R/W	E0H
82	ADC enable setting register1	R/W	83H
83	ADC enable setting register2	R/W	80H

84	ADC sample rate setting, TS pin control register	R/W	32H
85	GPIO [1:0] input range setting register	R/W	X0H
86	GPIO1 ADC IRQ rising edge threshold setting	R/W	FFH
87	GPIO1 ADC IRQ falling edge threshold setting	R/W	00H
8A	Timer control register	R/W	00H
8B	VBUS monitoring setting register	R/W	00H
8F	Over-temperature shutdown control register	R/W	01H

### Group 2 GPIO control

Address	Register Description	R/W	Default Value
90	GPIO0 control register	R/W	07H
91	LDO5 output voltage setting register	R/W	A0H
92	GPIO1 control register	R/W	07H
93	GPIO2 control register	R/W	07H
94	GPIO[2:0] signal status register	R/W	00H
95	GPIO3 control register	R/W	00H

### Group3 Interrupt control

Address	Register Description	R/W	Default Value
40	IRQ enable control register1	R/W	D8H
41	IRQ enable control register2	R/W	FFH
42	IRQ enable control register3	R/W	3BH
43	IRQ enable control register4	R/W	C1H
44	IRQ enable control register5	R/W	00H
48	IRQ status register1	R/W	00H
49	IRQ status register2	R/W	00H
4A	IRQ status register3	R/W	00H
4B	IRQ status register4	R/W	00H
4C	IRQ status register5	R/W	00H

### Group4 ADC data

Address	Register Description	R/W
56[7:0]	ACIN voltage ADC data high 8 bits	R
57[3:0]	ACIN voltage ADC data low 4 bits	R
58[7:0]	ACIN current ADC data high 8 bits	R
59[3:0]	ACIN current ADC data low 4 bits	R
5A[7:0]	VBUS voltage ADC data high 8 bits	R

5B[3:0]	VBUS voltage ADC data low 4 bits	R
5C[7:0]	VBUS current ADC data high 8 bits	R
5D[3:0]	VBUS current ADC data low 4 bits	R
5E[7:0]	AXP202 internal temperature monitoring ADC data high 8 bits	R
5F[3:0]	AXP202 internal temperature monitoring ADC data low 4 bits	R
62[7:0]	TS input ADC data high 8 bits, default monitoring battery temperature	R
63[3:0]	TS input ADC data low 4 bits, default monitoring battery temperature	R
64[7:0]	GPIO0 voltage ADC data high 8 bits	R
65[3:0]	GPIO0 voltage ADC data low 4 bits	R
66[7:0]	GPIO1 voltage ADC data high 8 bits	R
67[3:0]	GPIO1 voltage ADC data low 4 bits	R
70[7:0]	Battery instantaneous power high 8 bits	R
71[7:0]	Battery instantaneous power middle 8 bits	R
72[7:0]	Battery instantaneous power low 8 bits	R
78[7:0]	Battery voltage high 8 bits	R
79[3:0]	Battery voltage low 4 bits	R
7A[7:0]	Battery charge current high 8 bits	R
7B[3:0]	Battery charge current low 4 bits	R
7C[7:0]	Battery discharge current high 8 bits	R
7D[4:0]	Battery discharge current low 5 bits	R
7E[7:0]	System IPSOUT voltage high 8 bits	R
7F[3:0]	System IPSOUT voltage low 4 bits	R

Note: the battery power formula:

$P_{bat} = 2 * \text{register value} * \text{Voltage LSB} * \text{Current LSB} / 1000.$

(Voltage LSB is 1.1mV; Current LSB is 0.5mA, and unit of calculation result is mW.)

Address	Register Description	R/W	Default Value
B0	Battery charge coulomb counter data register[31:24]	R/W	00H
B1	Battery charge coulomb counter data register[23:16]	R/W	00H
B2	Battery charge coulomb counter data register[15:8]	R/W	00H
B3	Battery charge coulomb counter data register[7:0]	R/W	00H
B4	Battery discharge coulomb counter data register[31:24]	R/W	00H
B5	Battery discharge coulomb counter data register[23:16]	R/W	00H
B6	Battery discharge coulomb counter data register[15:8]	R/W	00H
B7	Battery discharge coulomb counter data register[7:0]	R/W	00H

B8	Coulomb counter control register	R/W	00H
B9	FuelGauge result register	R/W	00H

Coulomb calculation formula:

$C = 65536 * \text{current LSB} * (\text{charge coulomb counter value} - \text{discharge coulomb counter value}) / 3600 / \text{ADC sample rate}$ . Refer to REG84H setting for ADC sample rate; the current LSB is 0.5mA; unit of the calculation result is mAh. )

### REG 00H: Power Input Status

Bit	Descripton	R/W
7	ACIN presence indication 0:ACIN not exist; 1:ACIN exists	R
6	Indicating whether ACIN is usable	R
5	VBUS presence indication 0:VBUS not exist; 1:VBUS exists	R
4	Indicating whether VBUS is usable	R
3	Indicating whether the VBUS voltage is above $V_{\text{HOLD}}$ before used.	R
2	Indicating the battery current direction 0: the battery is discharging; 1: the battery is charging	R
1	Indicating whether ACIN and VBUS input short circuit on PCB	R
0	Indicating whether the boot source is ACIN or VBUS 0: Boot source isn't ACIN/VBUS; 1: Boot source is ACIN/VBUS.	R

### REG 01H: Power Working Mode and Charge Status Indication

Bit	Descripton	R/W
7	Indicating whether AXP202 is over-temperature 0: not over-temperature; 1: over-temperature	R
6	Charge indication 0:not charge or charge finished; 1: in charging	R
5	Battery existence indication 0:no battery connected to AXP202; 1:battery already connected to AXP202	R
4	Reserved and unchangeable	R
3	Indicating whether the battery enters the activate mode 0: not enter the activate mode; 1: already entered the activate mode	R
2	Indicating whether the charging current is lower than the expected current 0:actual charging current is the same as expected current; 1: actual charging current is lower than expected current	R
1-0	Reserved and unchangeable	R



## REG 02H:USB OTG VBUS Status Indication

Bit	Descripton	R/W
7-3	Reserved and unchangeable	
2	Indicating whether VBUS is valid or not, 1 means "valid"	R
1	Indicating whether VBUS Session A/B is valid, 1 means "valid"	R
0	Indicating Session End status, 1 means "valid"	R

## REG 04-0FH: Data Cache

Note: As long as one of the external powers, batteries or backup batteries exists, this data will be reserved and free from the startup and shutdown influence.

## REG 12H: Power Output Control

Default Value:XXH

Bit	Descripton	R/W	Default Value	
7	Reserved and unchangeable	RW	X	
6	LDO3 enable and disable control	0: disable; 1: enable	RW	X
5	Reserved and unchangeable	RW	X	
4	DC-DC2 enable and disable control	0: disable; 1: enable	RW	X
3	LDO4 enable and disable control	RW	X	
2	LDO2 enable and disable control	RW	X	
1	DC-DC3 enable and disable control	RW	X	
0	EXTEN enable and disable control	RW	X	

## REG 23H:DC-DC2 Output Voltage Setting

Default Value: XXH

Bit	Descripton	R/W	Default Value	
7-6	Reserved and unchangeable			
5-0	DC-DC2 output voltage setting [5:0]	0.7-2.275V, 25mV/step Vout=[0.7+(Bit5-0)*0.025]V	RW	X

## REG 25H:DC-DC2/LDO3 Dynamic Voltage Scaling Parameter Setting

Default Value:00H

Bit	Description		R/W	Default Value
7-4	Reserved and unchangeable			
3	LDO3 VRC ENABLING CONTROL 0: enable; 1: disable		RW	0
2	DC-DC2 VRC enabling control 0: enable; 1: disable		RW	0
1	LDO3 VRC voltage rising slope control	0: 25mV/15.625us=1.6mV/us 1: 25mV/31.250us=0.8mV/us	RW	1
0	DC-DC2 VRC voltage rising slope control	0: 25mV/15.625us=1.6mV/us 1: 25mV/31.250us=0.8mV/us	RW	0

## REG 27H:DC-DC3 Output Voltage Setting

Default Value: XXH

Bit	Description		R/W	Default Value
7	Reserved and unchangeable			
6-0	DC-DC3 output voltage setting	0.7-3.5V, 25mV/step $V_{out}=[0.7+(\text{Bit}6-0)*0.025]V$	RW	X

## REG 28H:LDO2/4 Output Voltage Setting

Default Value: XXH

Bit	Description		R/W	Default Value
7-4	LDO2 output voltage setting	1.8-3.3V, 100mV/step $V_{out}=[1.8+(\text{Bit}7-4)*0.1]V$	RW	X
3-0	LDO4 output voltage setting	1.25 1.3 1.4 1.5 1.6 1.7 1.8 1.9 2.0 2.5 2.7 2.8 3.0 3.1 3.2 3.3	RW	X

## REG 29H:LDO3 Output Voltage Setting

Default Value: XXH

*VQ.QW WPPIQ.PWE.CC*

Confidential

Page 34/48

Bit	Description	R/W	Default Value
7	LDO3 Mode select: 0: LDO mode, voltage can be set by [6:0] 1: enable/disable control mode, and voltage is determined by LDO3IN.	RW	0
6-0	LDO3 output voltage setting Bit6-Bit0	RW	X
			$V_{out}=[0.7+(Bit6-0)*0.025]V$

### REG 30H:VBUS-IPSOUT Power Path Management

Default Value: 6XH

Bit	Description	R/W	Default Value
7	the VBUS-IPSOUT path select control signal when VBUS is usable 0: whether to enable the path is decided by N_VBUSEN pin 1:VBUS-IPSOUT can be enabled, regardless of the N_VBUSEN status	RW	0
6	VBUS $V_{HOLD}$ voltage-limit control 0: not limit the voltage; 1: limit the voltage	RW	1
5-3	$V_{HOLD}$ setting	RW	100
			$V_{HOLD}=[4.0+(Bit5-3)*0.1]V$
2	Reserved and unchangeable		
1-0	VBUS current-limit selection when current-limit is enabled 00:900mA ; 01:500mA; 10:100mA; 11:not limit	RW	0

### REG 31H: $V_{OFF}$ Power off Voltage Setting

Default Value: X3H

Bit	Description	R/W	Default Value
7-4	Reserved and unchangeable		
3	PEK or GPIO edge wakeup function enable setting in Sleep mode 0: disable 1: enable This bit will be automatically cleared to 0 after writing, so "1" should be rewritten whenever enters the Sleep mode.		
2-0	$V_{OFF}$ setting	RW	011
			$V_{OFF}=[2.6+(Bit2-0)*0.1]V$ Default: 2.9V

## REG 32H: Shutdown Setting, Battery Detection and CHGLED Pin Control

Default Value: 46H

Bit	Description		R/W	Default Value
7	Shutdown Control Writing "1" to this bit will disable the AXP202 output.		RW	0
6	Battery monitoring function setting bit: 0: disable; 1: enable		RW	1
5-4	CHGLED pin function setting	00: high resistance 01: 25% 1Hz flicker 10: 25% 4Hz flicker 11: low level output	RW	00
3	CHGLED pin control setting	0: controlled by charging 1: controlled by register REG 32H[5:4]	RW	0
2	Output disable timing control	0: disable at the same time 1: contrary to the startup timing	RW	0
1-0	the delayed shutdown time of AXP202 after N_OE changes from low to high	00: 128mS; 01: 1S; 10: 2S; 11: 3S	RW	10

## REG 33H: Charging control 1

Default Value: CXH

Bit	Description		R/W	Default Value
7	Charging enable control bit 0: disable, 1:enable		RW	1
6-5	Charging target-voltage setting 00:4.1V; 01:4.15V; 10:4.2V; 11:4.36V		RW	10
4	Charging end-current setting 0: end when the charge current is lower than 10% of the set value 1: end when the charge current is lower than 15% of the set value		RW	0
3-0	Charge current setting $I_{charge} = [300 + (\text{Bit}3-0) * 100] \text{ mA}$		RW	X

## REG 34H: Charge Control 2

Default Value: 45H

Bit	Description	R/W	Default
-----	-------------	-----	---------

			Value	
7	Pre-charge timeout setting Bit1	00: 40 min; 01: 50min; 10: 60min; 11: 70min	RW	0
6	Pre-charge timeout setting Bit0		RW	1
5	Reserved			
4	CHGLED mode selection 0: always bright when charging 1: flicker when charging		RW	0
3-2	Reserved and unchangeable			
1-0	Constant-current mode timeout setting Bit1-0	00: 6Hours; 01: 8Hours; 10: 10Hours; 11: 12Hours	RW	01

### REG 35H: Backup Battery Charge Control

Default Value: 22H

Bit	Description	R/W	Default Value	
7	Backup battery charge enable control 0: disable; 1: enable	RW	0	
6-5	Backup battery charge target-voltage setting 00:3.1V; 01:3.0V; 10:3.6V; 11:2.5V	RW	01	
4-2	Reserved and unchangeable			
1-0	Backup battery charge current setting	00: 50uA; 01: 100uA; 10: 200uA; 11: 400uA	RW	10

### REG 36H: PEK Key Parameters Setting

Default Value: 9DH

Bit	Description	R/W	Default Value	
7-6	Startup time setting	00: 128mS; 01: 3S; 10: 1S; 11: 2S.	RW	01
5-4	Long-press time setting	00: 1S; 01: 1.5S; 10: 2S; 11: 2.5S.	RW	01
3	Automatic shutdown setting when the key press-time exceeds the shutdown time 0: disable; 1: enable	RW	1	
2	PWROK signal delay after the power startup 0:8mS; 1:64mS	RW	1	
1-0	Shutdown time setting	00: 4S; 01: 6S; 10: 8S; 11: 10S.	RW	01

REG 37H:DC-DC Working Frequency Setting

Default Value: 08H

Bit	Description		R/W	Default Value
7-4	Reserved and unchangeable			
3-0	DC-DC enable/disable frequency setting	Each level changes by 5%, Default Value1.5MHz $F=[1\pm(\text{Bit}3-0)*5\%]*1.5\text{MHz}$	RW	1000

REG 38H: VLTF-charge Battery Charge Under-temperature Threshold Setting

Default Value: A5H

Bit	Description		R/W	Default Value
7-0	Battery Under-temperature threshold setting when the battery is charging, M	$M*10H$ , when $M=A5H$ , corresponding voltage is 2.112V ; corresponding voltage ranges from 0V~3.264V	RW	A5H

$$V_{LTF\text{-charge}} = M * 10H * 0.0008V$$

REG 39H: VHTF-charge Battery Charge Over-Temperature Threshold Setting

Default Value: 1FH

Bit	Description		R/W	Default Value
7-0	The battery Over-temperature threshold setting when the battery is charging, N	$N*10H$ , when $N=1FH$ , the corresponding voltage is 0.397V; corresponding voltage ranges from 0V~3.264V	RW	1FH

$$V_{HTF\text{-charge}} = N * 10H * 0.0008V$$

REG 3AH: System IPSOUT Vwarning Level1

Default Value: 68H

Bit	Description	R/W	Default Value
7-0	System IPSOUT Vwarning Level1	RW	68H

## REG 3BH: System IPSOUT Vwarning Level2

Default Value: 5FH

Bit	Description	R/W	Default Value
7-0	System IPSOUT Vwarning Level2	RW	5FH

Corresponding voltage setting of REG3AH and REG3BH equals to (supposing the register value is n):  
 $V_{warning} = 2.8672 + 1.4mV * n * 4$

## REG 3CH: VLTF-discharge Battery Discharging Under-Temperature Threshold Setting

Default Value: FCH

Bit	Description	R/W	Default Value
7-0	battery Under-temperature threshold setting when the battery is discharging, M	M*10H, when M=FC, corresponding voltage is 3.226V ; corresponding voltage ranges from 0V~3.264V	RW FCH

$$V_{LTF-discharge} = M * 10H * 0.0008V$$

## REG 3DH: VHTE-discharge Battery Discharging Over-Temperature Threshold Setting

Default Value: 16H

Bit	Description	R/W	Default Value
7-0	The battery Over-temperature threshold setting when the battery is discharging, N	N*10H, when N=16H, corresponding voltage is 0.282V ; corresponding voltage ranges from 0V~3.264V	RW 16H

$$V_{LTF-discharge} = N * 10H * 0.0008V$$

## REG 80H:DC-DC Working Mode Selection

Default Value: E0H

Bit	Description	R/W	Default Value
7-3	Reserved and unchangeable		
2	DC-DC2 work mode control	0:PFM/PWM automatic switching 1: fixed PWM	RW 0
1	DC-DC3 work mode control		RW 0
0	Reserved and unchangeable		

### REG 82H: ADC Enable 1

Default Value: 83H

Bit	Description		R/W	Default Value
7	Battery voltage ADC enable	0: disable, 1: enable	RW	1
6	Battery current ADC enable		RW	0
5	ACIN voltage ADC enable		RW	0
4	ACIN current ADC enable		RW	0
3	VBUS voltage ADC enable		RW	0
2	VBUS current ADC enable		RW	0
1	APS voltage ADC enable		RW	1
0	TS pin ADC function enable		RW	1

### REG 83H: ADC Enable 2

Default Value: 80H

Bit	Description		R/W	Default Value
7	AXP202 internal temperature monitoring ADC enable	0: disable, 1: enable	RW	1
6-4	Reserved and unchangeable			
3	GPIO0 ADC function enable	0: disable, 1: enable	RW	0
2	GPIO1 ADC function enable		RW	0
1-0	Reserved and unchangeable			

### REG 84H: ADC Sample Rate Setting and TS Pin Control

Default Value: 32H

Bit	Description		R/W	Default Value
7-6	ADC sample rate setting	25×2 <sup>n</sup> The sample rate is 25, 50, 100, 200Hz respectively.	RW	0
5-4	TS pin output current setting: 00:20uA; 01:40uA; 10:60uA; 11:80uA		RW	11
3	Reserved and unchangeable			
2	TS pin function selection 0: battery temperature monitoring function, 1: external independent ADC		RW	0



	input			
1-0	TS pin current output method setting	00: disable 01: current output when charging 10: input when the ADC is sampling, reducing the power consumption 11: always enable	RW	1

### REG 85H: ADC Input Range

Default Value: X0H

Bit	Description	R/W	Default Value
7-2	Reserved and unchangeable		
1	GPIO1 ADC Input Range	0:0-2.0475V	RW
0	GPIO0 ADC Input Range	1:0.7-2.7475V	RW

### REG 86H: GPIO1 ADC IRQ Rising Edge Threshold Setting

Default Value: FFH

Bit	Description	R/W	Default Value
7-0	One LSB is 8mV	RW	FF

### REG 87H: GPIO1 ADC IRQ Falling Edge Threshold Setting

Default Value: 00H

Bit	Description	R/W	Default Value
7-0	One LSB is 8mV	RW	00

### REG 8AH: Timer Control

Default Value: 00H

Bit	Description	R/W	Default Value
7	The timer is timeout Write "1" to clear the status.	RW	0
6-0	Set the time, unit: minute Write full 0 to shutdown the timer.	RW	000000

## REG 8BH: VBUS Pin Detection and SRP Function Control

Default Value: 00H

Bit	Description	R/W	Default Value
7-6	Reserved and unchangeable		
5-4	VBUS valid voltage setting 00:4.0V; 01:4.15V; 10:4.45V; 11:4.55V	RW	00
3	VBUS Valid detect function setting: 0: disable, 1: enable	RW	0
2	VBUS Session detect function setting: 0: disable, 1: enable	RW	0
1	Discharge VBUS discharge function setting 0: to disable the VBUS discharge resistance; 1: to enable the VBUS discharge resistance	RW	0
0	Charge VBUS charge function setting 0: disable the VBUS charge resistance; 1: enable the VBUS charge resistance and charge the VBUS	RW	0

## REG 8FH: Function Setting, Over-temperature Shutdown, etc.

Default Value: 21H

Bit	Description	R/W	Default Value
7-3	Reserved and unchangeable	RW	0
2	AXP202 internal over-temperature shutdown setting 0: not shutdown; 1: shutdown	RW	0
1-0	Reserved and unchangeable		

## REG 90H: GPIO0 function Setting

Default Value: 07H

Bit	Description	R/W	Default Value
7	GPIO0 rising edge IRQ or Wakeup function	RW	0
6	GPIO0 falling edge IRQ or Wakeup function		
5-3	Reserved and unchangeable	RW	0

2	GPIO0 pin function setting Bit 2-0	000: output low 001: output high (3.3V) 010: general input function 011: low noise LDO5 100:ADC input 1XX: floating	RW	1
1			RW	1
0			RW	1

### REG 91H: LDO5 Output Voltage and EXTEN/GPIO Output High Level Setting

Default Value: A5H

Bit	Description	R/W	Default Value
7-4	LDO5 output voltage setting $V_{out}=[1.8 + (\text{Bit}7-4) * 0.1]V$ ; default=1.8+10*0.1=2.8V	RW	1010
3	Reserved and unchangeable		
2-0	EXTEN and GPIO[1:0] output high level setting 000:1.8V;001:2.5V;010:2.8V;011:3.0V;100:3.1V;101:3.3V;110:3.4V;111:3.5V	RW	101

### REG 92H: GPIO1 Function Setting

Default Value: 07H

Bit	Description	R/W	Default Value
7	GPIO1 rising edge IRQ or Wakeup function	RW	0
6		RW	0
5-3	Reserved and unchangeable	RW	0
2-0	GPIO1 pin function setting 000: output low 001: output high (3.3V) 010: general input function 011: low noise LDO 100:ADC input 1XX: floating	RW	111

### REG 93H:GPIO2 Function Setting

Default Value: 07H

Bit	Description		R/W	Default Value
7	GPIO2 rising edge IRQ or Wakeup function	0: disable 1: enable	RW	0
6	GPIO2 falling edge IRQ or Wakeup function		RW	0
5-3	Reserved and unchangeable		RW	0
2-0	GPIO2 pin function setting	000: output low 001: floating 010: general input function XXX: floating	RW	111

### REG 94H:GPIO[2:0] Signal Status Setting and Monitoring

Default Value: 00H

Bit	Description		R/W	Default Value
7	Reserved and unchangeable		R	
6	GPIO2 input status	0: input low level 1: input high level	R	
5	GPIO1 input status		R	
4	GPIO0 input status		R	
3-0	Reserved and unchangeable			

### REG 95H:GPIO3 Setting

Default Value: 00H

Bit	Description		R/W	Default Value
7	GPIO3 rising edge IRQ or Wakeup function	0: disable 1: enable	RW	0
6	GPIO3 falling edge IRQ or Wakeup function		RW	0
5-3	Reserved and unchangeable			
2	GPIO3 function setting	0: NMOS Open Drain output 1: number input function	RW	0
1	GPIO3 output status	0: output low level, NMOS enable 1: floating, NMOS disable	RW	1
0	GPIO3 input status	0: input high level 1: input low level	R	

## REG 40H and 48H: IRQ enable1 and IRQ Status 1

IRQ enable1 and REG40H: Default Value: D8H

Bit	Description	R/W	Default Value
7	ACIN over-voltage, IRQ enable	RW	1
6	ACIN connected, IRQ enable	RW	1
5	ACIN removed, IRQ enable	RW	0
4	VBUS over-voltage, IRQ enable	RW	1
3	VBUS connected, IRQ enable	RW	1
2	VBUS removed, IRQ enable	RW	0
1	VBUS is available, but lower than $V_{HOLD}$ , IRQ enable	RW	0
0	Reserved and unchangeable	RW	0

IRQ status 1, REG48H: Default Value: 00H

Bit	Description	R/W	Default Value
7-0	The meaning of status bit respectively corresponds to each bit of 40H; For example: Bit7 is ACIN over-voltage IRQ status bit	RW	0

## REG 41H and 49H: IRQ enable2 and IRQ Status2

IRQ enable2, REG41H: Default Value: FFH

Bit	Description	R/W	Default Value
7	Battery connected, IRQ enable	RW	1
6	Battery removed, IRQ enable	RW	1
5	Battery activate mode, IRQ enable	RW	1
4	Exit battery activate mode, IRQ enable	RW	1
3	Be charging, IRQ enable	RW	1
2	Charge finished, IRQ enable	RW	1
1	Battery over-temperature, IRQ enable	RW	1
0	Battery low-temperature, IRQ enable	RW	1

IRQ status 2, REG49H: Default Value: 00H

Bit	Description	R/W	Default Value
7-0	Meaning of the Status bit respectively corresponds to each bit of 41H.	RW	0

## REG 42H and 4AH: IRQ enable3 and IRQ Status 3

IRQ enable3, REG42H: Default Value: 03H

Bit	Description	R/W	Default Value
7	AXP202 internal over-temperature, IRQ enable	RW	0
6	Charge current is lower than the set current, IRQ enable	RW	0
5	Reserved and unchangeable		
4	DC-DC2 output voltage is lower than the set value, IRQ enable	RW	0
3	DC-DC3 output voltage is lower than the set value, IRQ enable	RW	0
2	LDO3 output voltage is lower than the set value, IRQ enable		
1	PEK short press, IRQ enable	RW	1
0	PEK long press, IRQ enable	RW	1

IRQ enable 3, REG4AH: Default Value: 00H

Bit	Description	R/W	Default Value
7-0	Meaning of the Status bit respectively corresponds to each bit of 42H.	RW	0

## REG 43H and 4BH: IRQ enable4 and IRQ Status 4

IRQenable4, REG43H: Default Value: 01H

Bit	Description	R/W	Default Value
7	N_OE startup, IRQ enable	RW	0
6	N_OE shutdown, IRQ enable	RW	0
5	VBUS valid, IRQ enable	RW	0
4	VBUS invalid, IRQ enable	RW	0
3	VBUS Session A/B IRQ enable	RW	0
2	VBUS Session End IRQ enable	RW	0
1	APS low-voltage, IRQ enable (LEVEL1)	RW	0
0	APS low-voltage, IRQ enable (LEVEL2)	RW	1

IRQ status 4, REG4BH: Default Value: 00H

Bit	Description	R/W	Default Value
7-0	Meaning of the Status bit respectively corresponds to each bit of 43H.	RW	0

## REG 44H and 4C:IRQ Enable 5 and IRQ Status 5

IRQenable5, REG44H, Default Value: 00H;

Bit	Description	R/W	Default Value
7	Timer timeout, IRQ enable	RW	0
6	PEK press rising edge, IRQ enable	RW	0
5	PEK press falling edge, IRQ enable	RW	0
4	Reserved and unchangeable	RW	0
3	GPIO3 input edge trigger, IRQ enable	RW	0
2	GPIO2input edge trigger, IRQ enable	RW	0
1	GPIO1input edge trigger or ADC input, IRQ enable	RW	0
0	GPIO0 input edge trigger, IRQ enable	RW	0

IRQ status 5, REG4CH: Default Value: 00H

Bit	Description	R/W	Default Value
7-0	Meaning of the Status bit respectively corresponds to each bit of 44H	RW	0

Note: Writing 1 to all IRQ status register bits will clear corresponding status.

REG B8H: Coulomb Counter Control

Default Value: 00H

Bit	Description	R/W	Default Value
7	coulomb counter enable/disable control	RW	0
6	Coulomb counter suspend control. Writing "1" to this bit will suspend the Coulomb counter, and this bit will be automatically cleared to 0 as well.	RW	0
5	Coulomb counter clear control. Writing "1" to this bit will clear the coulomb counter, and this bit will automatically be cleared to 0.	RW	0
4-2	Reserved and unchangeable	RW	0
1-0	Decrypt the start bit. Automatically clear to 0 after the decryption.	RW	0
0	Whether the decryption has finished or not 0: not finished 1: finished	RW	0

REG B9H: FuelGuage Result

Default Value: 7FH

Bit	Description	R/W	Default Value
7	FuelGuage system control 0: normal work mode 1: work suspension	RW	0
6-0	FuelGuage result, percentage	R	7F

## 11 . Package

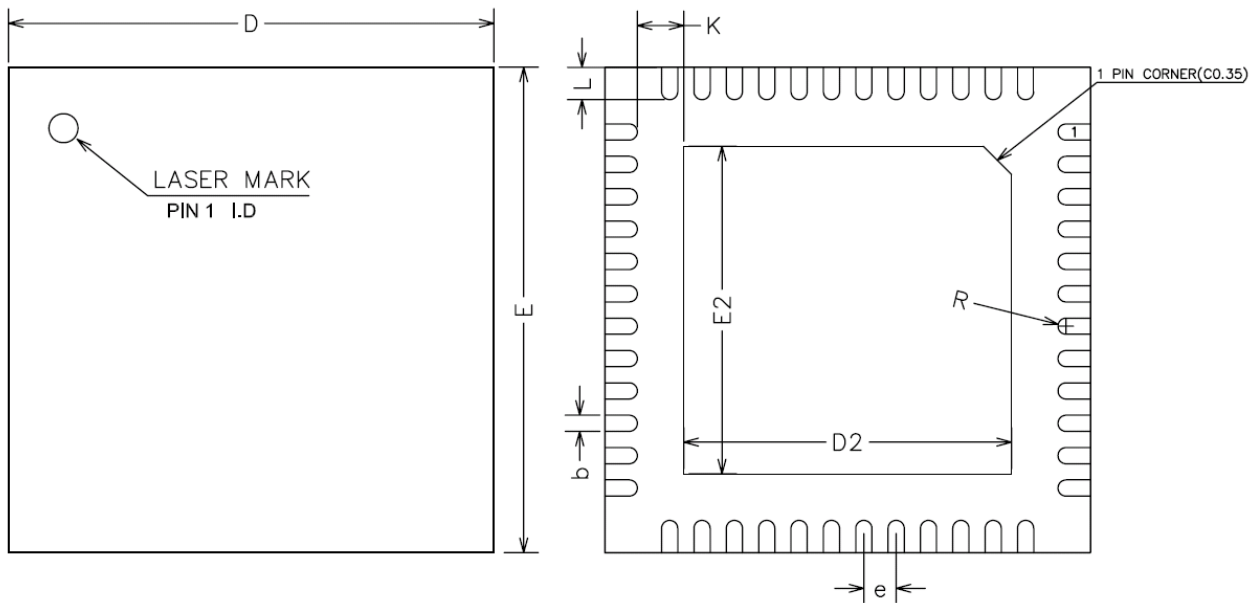

COMMON DIMENSIONS  
(UNITS OF MEASURE=MILLIMETER)

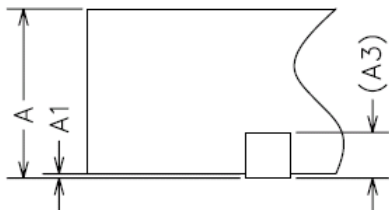

SYMBOL	MIN	NOM	MAX
A	0.70	0.75	0.80
A1	0	0.02	0.05
A3	0.20REF		
b	0.15	0.20	0.25
D	5.90	6.00	6.10
E	5.90	6.00	6.10
D2	3.95	4.05	4.15
E2	3.95	4.05	4.15
e	0.35	0.40	0.45
K	0.20	-	-
L	0.35	0.40	0.45
R	0.09	-	-

© 2011 X-Powers Limited - All rights reserved

X-Powers cannot assume responsibility for use of any circuitry other than circuitry entirely embodied in a X-Powers product. No circuit patent licenses, copyrights, or other intellectual property rights are implied. X-Powers reserves the right to make changes to the specifications and products at any time without notice.



[www.s-manuals.com](http://www.s-manuals.com)