

**MicroMax™ Series 670
Single Axis Board Level
Mirror Positioning System**

INSTRUCTION MANUAL

Revision 2, December 21, 1998

CAMBRIDGE TECHNOLOGY, INC.
109 Smith Place
Cambridge, MA 02138
U.S.A.

TEL.617-441-0600 FAX.617-497-8800

TABLE OF CONTENTS

- 1.0. Introduction**
- 2.0. Servo Amplifier Specifications**
- 3.0. Description of Operation**
 - 3.1. Overview**
 - 3.2. Mechanical Layout**
 - 3.3. Input Power**
 - 3.4. Position Demodulator**
 - 3.5. AGC Circuit**
 - 3.6. Command Input**
 - 3.6.1. Input Configuration Jumper**
 - 3.6.2. Analog Input**
 - 3.6.3. Digital Input**
 - 3.6.4. Command Input Scale Factor Calculation**
 - 3.6.5. Command Offset**
 - 3.6.6. Command Offset Scale Factor Calculation**
 - 3.6.7. Slew Rate Limiter**
 - 3.7. Tuning Section**
 - 3.7.1. Class 1**
 - 3.7.2. Class 0**
 - 3.8. Output Amplifier**
 - 3.8.1. Overview**
 - 3.8.2. Output Stage Disable**
 - 3.9. Reference Voltages**
 - 3.10. Notch Filter Socket**
 - 3.11. Observation/Control Header**
 - 3.11.1. User Outputs**
 - 3.11.2. Remote Shutdown Input**
 - 3.12. LED Status Indicator**
 - 3.13. Protection Circuits**
 - 3.13.1. Startup Sequence**
 - 3.13.2. Error Shutdown**
 - 3.14. Mirror Alignment Mode**
- 4.0. Operating Instructions**
 - 4.1. Precautions and Warnings**
 - 4.2. First Time Startup**
- 5.0. Terms and Conditions of Sale**

6.0. Appendices

6.1. Tune-up Procedure

6.1.1. Precautions

6.1.2. Overview

6.1.2.1 The Order in which Adjustments should be made

6.1.3. Materials Needed

6.1.4. Initial Setup

6.1.4.1 Board Silkscreen Potentiometer Identification

6.1.5. Adjusting Position Output Scale Factor and AGC Linearity

6.1.5.1. Closed Loop Method

6.1.5.2. Open Loop Method

6.1.6. Command Input Scale Adjustment

6.1.7. Closing the Servo Loop

6.1.7.1. Class 1

6.1.7.1.1. Coarse Tuning

6.1.7.1.2. Fine Tuning

6.1.7.1.3. Slew Rate Limiter Speed Adjustment

6.1.7.2. Class 0

6.1.7.2.1. Coarse Tuning

6.1.7.2.2. Fine Tuning

6.1.8. Aligning the Mirrors

6.1.9. Matching the X and Y Channels

6.2. 6740-XX Notch Filter Module

6.2.1 Background Theory

6.2.2 Notch Filter Tuning

6.2.2.1 Determining Fr

6.2.2.2 Selecting the Proper 6740-XX NFM

6.2.2.3 Inserting and Tuning the 6740-XX NFM

6.3 Schematics and Assembly Drawings

1.0. Introduction

As the complexity and specification requirements of today's optical systems increase, so does the need for high performance, high accuracy, and compact mirror positioning systems. The MicroMax™ Series 670 system was designed for applications that require high performance specifications.

The Series 670 Single axis Board-Level Mirror Positioning System consists of a single-channel servo amplifier on a 2.50" x 4.00" board and a high performance scanner. The scanner is designed for a specific range of inertial loads, allowing mirrors with inertias from less than 0.001 gm-cm² to greater than 100,000 gm-cm² to be precisely controlled.

This manual describes the 670 servo board electronics. (A separate manual will describe the particular motor matched to this system.) This manual describes the servo board in detail so the user can better integrate this mirror positioning sub-system into the end use application. At the end of the manual is a complete set of schematics and assembly drawings.

Please read this manual in order to fully understand the operation of this mirror positioning system. The optical scanners used in this system are delicate devices and can be damaged if mishandled. Do not attempt to retune the drive electronics until the tune-up procedure in section 6.0. is fully understood. Failure to do so could result in serious damage to both the scanner and electronics.

2.0. Servo/Amplifier Specifications

MicroMax 670XX Board Level Drive Electronics

All angles are in mechanical degree. All specifications apply after a 1 minute warm up period.

Analog Input Impedance:	200K \pm 1% ohms (Differential) 100K \pm 1% ohms (Single Ended)
Position Output Impedance:	1K \pm 1% ohms (For all observation outputs)
Position Input Scale Factor:	0.5 volt/ $^{\circ}$ (2 $^{\circ}$ /volt)
Analog Position Input Range:	\pm 10 volts max
Digital Position Input Range:	2 ¹⁶ dac counts
Non-Linearity of 16 Bit Digital Input:	0.006% of full scale, max
Position Offset Range:	\pm 2 volts
Pos. Output Scale Factor:	0.5 volt/ $^{\circ}$
Error Output Scale Factor:	0.5 volt/ $^{\circ}$
Velocity Output Scale Factor:	Analog (scaled by position differentiator gain)
Fault Output:	Open Collector: 1K ohm output impedance (pulls down to -15V), with 10mA sink capability
Temperature Stability of Electronics:	20PPM per $^{\circ}$ C
Input Voltage Requirements:	+/-15 to +/-28VDC (current varies with motor configuration)
Maximum Drive Current Limit:	
Peak:	10 Amperes
RMS:	5 Amperes (power supply, load, & heat sink dependent.)
Operating Temperature Range:	0 - 50 $^{\circ}$ C
Size:	4.0in x 2.in x 1.06in 10.16cm x 6.35cm x 2.69cm
Weight:	3.07 ounces (87 grams)

3.0. Description of Operation

3.1. Overview

The 670 system's servo electronics are contained on a compact 2.5" x 4.0" multi-layer printed circuit board. Each servo board has been tuned to the customer's particular mirror inertia so that no adjustments are necessary unless the mirror inertia is changed. For those experienced in servo electronics, there is a tuning section included in section 6.0. Also included is a complete set of schematic and assembly drawings.

****Warning!** Do not attempt to retune the servo until section 6.0. is fully understood. Damage to the scanner could result.

****Note:** If by customer request the system was sent untuned, the user will have to follow the tuning procedures in section 6.0 before the system will be ready for use. Also, if the system was shipped without a mirror or other customer load, the system will always be shipped untuned.

The basic operation of the servo is: Accept a command input voltage signal and turn it into a stable, repeatable, angular position of the scanner's output shaft. The amplifier does this by combining the input information with the feedback information from the scanner to form an error signal. The servo then strives to force this error signal to zero by rotating the scanner's shaft. It is this "following" of the input signal that allows it to control the scanner's angular position.

The rest of the electronics on the card is used to provide DC power and to monitor various error conditions to ensure proper operation of the system.

3.2. Mechanical Layout

Refer to the 670 Outline Drawing located in section 6.0. for details of the mechanical layout.

The 670 servo board has four clearance holes for #4 screws located at the four corners of the board. It is recommended to use all four mounting holes. For best noise rejection, always ground one of the screw holes on the scanner connector (J2) side of the board to the chassis ground of the instrument. For maximum support and heatsinking, there are two #6 holes at the left and right extremes of the black heat-sink bracket, and two #4 holes near the middle of the bracket. ***Bolting this side of the bracket to a large plate, heat sink extrusion, or machine chassis and using thermal joint compound will greatly increase the maximum power dissipation of the 670 board.*** If this is not done, expect no more than minimal output power capability and marginal performance under moderate loads. It is recommended that all four of the heat sink bracket fasteners be of the "socket head" type.

During system integration, ensure that there is sufficient clearance around and under the board to keep the circuits from being shorted out, and that all of the connectors, adjustment potentiometers, and test points are accessible.

3.3. Input Power

Refer to the 670 Schematic located in section 6.0. for details on this section.

Input DC power is fed onto the board via the 4-pin male Molex connector, J3. The mating female connector, Molex # 15-24-4048 with Molex pins # 02-08-1202 have been included with the system and contained in the connector kit.

The supply voltages are connected directly to the output amplifier. The voltage need not be highly regulated, but for high accuracy applications, it is recommended the voltages be as free from noise as practical. Filter capacitors on the 670 board help to supply the board's transient current demands from the power supplies allowing for smaller supplies in general.

The 670 board is normally used with +/- 28V supplies. The input voltage is regulated down to +/- 15V for the analog circuitry and +5V for the digital circuitry. The table below shows the voltage ranges along with fault trip point levels and proper jumper and resistor settings. Consult the table below for configuring the system with alternate supply voltages:

<u>Supply Voltage Range</u>	<u>Trip Point Voltage</u>	<u>Jumper Connect</u>	<u>R94 & R96 Values</u>
+/-18v to +/-28v(max)	< +/- 17v	-	13.3k
+/-15v to +/-18v(max)	< +/- 12v	W2 & W3	7.87k

For operation within the +/-15v to +/-18v, the supply voltage will not be regulated on board, and will connect directly to the analog circuitry. ***In this situation, damage to the board will result if the voltage exceeds +/-18v!*** For these situations, it is highly recommended that low noise, regulated power supplies with over-voltage "crowbar" type protection be used. Refer to the next paragraph for instruction.

In general the higher the voltage, up to +/-28V, the shorter the large angle step response time or the better the performance. The systems are factory tested at +/-28V. The input current requirements vary depending on a number of parameters e.g. which type of scanner is being used, how the system is tuned, what type of waveform is being input. Power supply design should consider the current required to run all of the analog circuitry, +/-150mA, and the current required to run the scanner at the maximum RMS current demands.

The 670 board has power fault monitoring to ensure proper "turn-off" sequencing whether intentional or accidental. Should the input supply voltage dip below a "Trip Point Voltage" minimum set by the fault detector, the servo will turn off and stay off until the input voltage has

attained the proper level. Proper gauging of wire and power supply sizing should be considered during the design integration of the system.

****Note:** If the power supply cannot support the amount of current drawn by the servo board, the servo board will automatically shut down. This is part of the normal "turn-off" circuitry of the board. Do not use power supplies that "fold-back" in voltage when too much current is drawn. This could result in a continuous fault cycling that could damage the scanner/servo combination.

Shown below is the pinout for J3 input power connector:

- Pin 1 = +Supply Voltage
- Pin 2 = +Supply Voltage Return
- Pin 3 = -Supply Voltage Return
- Pin 4 = -Supply Voltage

3.4. Position Demodulator

A differential current signal is obtained from the position detector within the scanner. The amplitude of this signal is modulated by the scanner output shaft angle or "position". Referring to the 670 schematic, Ia and Ib are converted to voltages, Va and Vb, by the two transimpedance amplifiers in the position demodulator section. The position output voltage, Vp, is then detected as the difference of these two voltages. This signal is then sent on to the tuning section of the amplifier and to the outside world via a buffer amplifier. This buffering allows the user to monitor the scanner's position without fear that the measurement device will affect the position signal. The position signal is available at J4.2 or TP1. Use TP2 or W7.2 for the return. The scale factor for this output is 0.500 volt/° mechanical, standard.

3.5. AGC Circuit

The output signal of a scanner's position detector is powered by an AGC signal generated on the 670 board. To monitor this signal, use TP7. Use TP2 or W7.2 for the ground return. The 670 board's AGC circuit monitors the sum of voltages Va and Vb and forces this sum to be constant at all times. Thus, any drift of the position detector is stabilized to a very high degree. Since the angular excursion of the scanner is inversely proportional to Vagc, this circuit is also used to adjust the position detector scale factor or the "Position Output Scale Factor". However, this should only be done when retuning the original scanner, or when matching a new scanner to the servo board. The scanner's scale factor should never need readjusting during its lifetime. Changing the position output scale factor in this manner directly affects the system's loop gain. Turning R13 to set a scanner's field size will result in changed dynamic performance. Refer to section 6.0. for adjusting the output scale factor. *****Caution: Misadjustment of R13 could result in damage to the scanner. Refer to section 6.0 before adjustments are made.**

The apparent linearity of the position detector is affected by component tolerancing of the servo board's position demodulator and by other factors within the scanner. These nonlinearities can

be partially eliminated by the R77 trim on the 670 board. This trim is adjusted so that the AGC signal changes minimally through a full angular shaft rotation. This signal should not need adjusting during the normal lifetime of the scanner. This adjustment should only be made when retuning the original scanner or when matching a new scanner to the servo board. Refer to section 6.0 for details on this procedure.

3.6. Command Input

3.6.1 Input configuration jumper (W4)

(AN) = Analog command signal

(DI) = Digital command signal (from digital input option module)

(SE) = Single ended input

The board input can accept a two or three wire connection. For single ended two-wire inputs, the unused op-amp input is strapped to GND #6 via W4. The table below indicates where to connect signal, ground and W4 jumpers for the particular input configuration:

<u>Input configuration</u>	<u>W4 pin strapping</u>	<u>(+) in</u>	<u>(-) in</u>	<u>GND</u>
(AN) Differential	1-3	J1.3	J1.1	J1.2
(AN) Non-inverting (SE)	1-3, 4-6	J1.3	-	J1.2
(AN) Inverting (SE)	3-4	-	J1.1	J1.2
(DI) Non-inverting	3-5, 4-6	-	-	-
(DI) Inverting	5-6, 3-4	-	-	-

3.6.2. Analog Input

The analog command input signal is applied via J1. The input voltage range is +/-10V for full angular excursion. Ensure that W4 and the input signal on J1 are connected for the particular configuration desired from the chart above. The scanner will move as follows:

input voltage = -10V	position = full CCW angle
input voltage = 0V	position = center
input voltage = +10V	position = full CW angle

The connector kit included with your system has the necessary hardware to build the input connector J1. The connector is Molex #50-57-9404 with Molex pins #16-02-0103.

3.6.3. Digital Input Module

The digital input option employs a 16-bit digital-to-analog converter or DAC (Analog Devices #AD7846JP). The DAC converts the digital word presented at its input to an analog output voltage. This voltage is proportional to the 16-bit word. Refer to the applicable Users Guide for detailed information with regard to the operation of the particular digital input option to be used.

3.6.4. Command Input Scale Factor Calculation

The Command Input scale factor is defined as the number of volts required at the input of the servo board to cause the scanner's output shaft to rotate one mechanical degree. For some applications, fine control of this scale factor is critical. Also, since the input voltage is limited to +/-10V, this also sets the maximum controllable angle or Input Range of the system. This Input Range is also referred to as the "fieldsize" of the system.

The 670 Single Axis Mirror Positioning System is normally set up for the maximum allowable scan angle for the application unless otherwise specified by the customer. The maximum fieldsize for all Cambridge Technology scanners is +/-20° mechanical. As the Command Input scale factor increases, the inherent fieldsize of the system decreases. Thus, 0.5V/° system will yield +/-20°, 1.0V/° will yield +/-10°, 2.0V/° will yield +/-5°, etc.

Note: It is possible to set the scale factor less than 0.5V/°, however it will allow the input signal to attempt to drive the scanner further than 20°. This will cause the system to sense the overposition and shut the servo down. Ensure that no matter what the servo's input scale factor is set to, the input signal stays within the bounds that keep the scanner within its normal +/-20° range.

The Command Input scale factor is controlled by the following factors:

- 1.) Position Output Scale Factor - always set to 0.5V/° mechanical (unless otherwise stated)
- 2.) Error integrator summing resistor ratio, R29/R30 - usually set to 1:1
- 3.) Slew rate limiter voltage gain, R89/R83 - usually set to 1.074:1
- 4.) Command Input scale adjustment, R51 & R82 - adjustable from ~0.8:1 to 1:1

****Note:** The R51 and R82 combination allows the user to make small adjustments to the Command Input scale factor. For gross changes use the equations shown below to determine the value of R30. For small changes, use R51. For minimum drift from R51, set the pot to the maximum CW position. Then use the procedure in section 6.0 to measure the input scale factor obtained.

The following equation describes the interaction of the above factors:

$$\text{Command Input Scale Factor} = \text{Position Output Scale Factor} \times (\text{R30/R29}) \times \text{Slew Rate Limiter Voltage Gain} \times \text{Command Input Scale Adjustment}$$

For example: Let

$$\begin{aligned} \text{Position Output Scale Factor} &= 0.5\text{V}/^\circ \text{ mechanical} \\ \text{Slew Rate Limiter Voltage Gain} &= 1.074:1 \\ \text{Command Input Scale Adjustment} &= 0.9311:1 \\ \text{R29} &= 10\text{Kohm} \end{aligned}$$

and the desired Command Input Scale Factor = 2:1 or 1.0V/° mechanical

Thus,

$$R30 = (\text{Command Input Scale Factor} * R29) / (\text{Position Output Scale Factor} * \text{Slew Rate Limiter Voltage Gain} * \text{Command Input Scale Adjustment})$$

or

$$R30 = (1.0V/° \text{ mechanical} * 10Kohm) / (0.5V/° \text{ mechanical} * 1.074 * 0.9311)$$

$R30 = \underline{20Kohm}$ (Use a high quality metal film resistor, RN55C, for best thermal drift characteristics.)

The Command Input Range or “Fieldsize” is now determined as the product of the range of the Command Input voltage and the Command Input scale factor. For the above example:

$$\begin{aligned} \text{Command Input Range} &= +/-10V * 1.0V/° \text{ mechanical} \\ \text{Command Input Range} &= +/-10° \text{ mechanical} = \underline{20° \text{ mechanical pk-pk}} \end{aligned}$$

A detailed procedure is included in the appendix 6.0 on how to set the Command Input Scale Adjustment. Basically, R51 is adjusted so that the proper voltage ratio is measured from W4 to the position output voltage measured on TP1.

3.6.5. Command Offset

The Command Offset is used to add a small DC offset for a specific application requiring it. Two methods are available on the 670 board. The first is an on-board adjustment pot, R1. R1 is a 15-turn Cermet potentiometer whose output voltage ranges from -5V to +5V. Its offsetting contribution is controlled by R10. The nominal offset contribution is +/-20% of the input range.

The second Command Offset input is accepted via the 4-pin Molex C-grid connector J1.4. Use J1.2 for the return. This is a high impedance input with a +/-10V range. Its contribution is controlled by R85.

****Note:** When the external Command Offset input is not intended to be used, do not install R85. If R85 has been installed, but J1.4 is not connected to a low impedance signal source, short J1.4 to J1.2. Otherwise, a large unintended offset voltage will be added to the command input.

3.6.6. Command Offset Scale Factor Calculation

Since there are two Command Offset inputs, there are two Command Offset Input Scale Factors to describe.

The command input offset adjustment potentiometer, R1, controls a DC input signal that is added to the normal input signal. R10 controls the contribution of this input. The following equation can be used to determine the value of R10 for a desired Command Offset Range:

$$R10 = (((+V_r) - (-V_r)) \times R89 \times (R29/R30)) / (\text{Position Output Scale Factor} \times \text{Command Offset Range})$$

if $V_r = 5V$
 $R89 = 10Kohms$
 $R29 = 10Kohms$
 $R30 = 20Kohms$
 $\text{Position Output Scale Factor} = 0.5V / ^\circ \text{mechanical}$
 $\text{Command Offset Range} = 0.25^\circ \text{mechanical}$

then $R10 = (10V \times 10Kohms \times (10K/20K)) / (0.5V / ^\circ \text{mechanical} \times 0.25^\circ \text{mechanical})$
 $R10 = 400Kohms$

The other type of Command Offset is brought in from an external source similar to the normal input. This input can be used while simultaneously using the analog or digital input. The resultant signal is the algebraic sum of both. The following equation is used to determine the value of R85 in order to obtain the proper Command Offset Range:

$$R85 = ((+\text{Offset In} - -\text{Offset In}) \times R89 \times (R29/R30)) / (\text{Position Output Scale Factor} \times \text{Position Offset Range})$$

if $\text{Offset In} = 10V$
 $R89 = 10Kohms$
 $R29 = 10Kohms$
 $R30 = 20Kohms$
 $\text{Position Output Scale Factor} = 0.5V / ^\circ \text{mechanical}$
 $\text{Command Offset Range} = 0.25^\circ \text{mechanical}$

then $R85 = (20V \times 10Kohms \times (10K/20K)) / (0.5V / ^\circ \text{mechanical} \times 0.25^\circ \text{mechanical})$
 $R85 = 800Kohms$

****Note:** For best drift characteristics, select a Command Offset Range that is fairly small compared to the Input Range of the system.

****Note:** The algebraic sum of all inputs must not exceed +/-20° mechanical or the system will go into "fault" mode. This is described in detail in section 3.9.

3.6.7. Slew Rate Limiter

All of the Command Input signals, whether analog, digital, or offset, must pass through the "slew rate limiter". The slew rate limiter is a circuit used for controlling the system for large angle moves. During these moves, large currents are drawn by the servo's output amplifier. If these

exceed the capability of the power supply or the board's output amplifier, noise and even instability can result. By controlling the maximum slew rate of the input signal, the system's output amplifier can be kept from saturating. This is always advantageous for accurate positioning of the scanner. For some applications, fast large-angle positioning is not needed. For those applications, the slew rate limiter can be used to slow the maximum angular speed attained for these large moves, thus decreasing the amount of wobble and jitter associated.

The slew rate limit is controlled by R78. Refer to section 6.0 for adjusting the slew rate limiter. ****Note:** During start up, the output of the slew rate limiter is grounded by the action of an analog switch, U15B, for about 3 seconds. This allows the servo time to stabilize (about 1 second).

****Caution:** Do not adjust R78 without complete understanding of the appropriate section of 6.0. Damage to the scanner could result.

3.7. Tuning Section

The tuning section can be configured two ways depending on the user's needs. If extreme positioning repeatability is required, the servo board is set up as a class 1 servo. If fast positioning is of paramount importance, the servo board has class 0 capabilities.

The class of servo is determined by how many error integrators are in the servo loop. The error integrator of a class 1 servo makes the system settle to a very high degree of accuracy. Even as friction or other torque disturbances try to affect repeatability, the integrator will eventually take out all error. This is done at a slight speed penalty. Most applications' requirements are met very well using the class 1 servo.

Class 0 servos are slightly faster and more stable than class 1 servos. However, the tradeoff is that any finite friction causes a window of non-repeatability to form around the commanded position. The error is equal to:

$$\text{Error} = \Gamma_D / K_S \quad \text{where, Error} = \text{difference between actual and commanded position in radians}$$

Γ_D = the disturbance torque in dyne-cm
 K_S = the servos stiffness in dyne-cm/radian

Certain applications do allow for the use of the class 0 configuration, along with its inherent non-repeatability. It is described below after the class 1 section.

3.7.1. Class 1

Our class 1 servo consists of the following circuits: position differentiator, position amplifier, error integrator, current integrator, and summing amplifier. The transfer function can be characterized by the following differential equation:

$$V(t) = A1 * \frac{d(V_{pos}(t))}{dt} + A2 * V_{pos}(t) + A3 * \int Error(t)dt + A4 * \int I(t)dt$$

where:

$V(t)$ = output of summing amplifier

$A1 - A4$ = coefficients that are adjusted with the tuning pots R25, R28, R31, and R59 respectively.

$Error(t)$ = the error signal generated as the difference between the position signal, V_p , and the output of the slew rate limiter (command signal).

$I(t)$ = the current flowing through the motor coil.

The position differentiator takes the first derivative of the position signal to yield angular velocity. This velocity signal is one of two sources of damping for the servo. Its -3db bandwidth is set relatively low. This is to prevent high frequency noise, present on any differentiated signal, from entering the summing amplifier. Its contribution to the servo is to provide damping at low frequency and is controlled by R25.

The position amplifier uses the position signal to generate an "electrical spring". Its contribution is controlled with R28.

The error integrator compares the actual position to the commanded position and integrates the difference over time. This signal will allow the scanner to overcome any slight spring or friction yielding a zero steady-state error. Extremely repeatable positioning is thus obtained. The ultimate accuracy is then controlled by the repeatability of the position detector contained within the scanner. The contribution of this amplifier to the servo response is controlled by R31.

The current integrator produces a signal proportional to the integral of the current flowing through the rotor. Since the current flowing through the rotor is proportional to the torque produced, it is also proportional to the angular acceleration. Thus, the integral of current can be used as another source of velocity information, hence damping. The advantage of this form of damping is its inherent low noise. Its bandwidth can be set high without degrading its signal-to-noise ratio. The overall bandwidth of the system can be extended much further than with position differentiation alone. The current integrator is considered the high frequency damping source and is adjusted with R59. The current integrator is high-passed into the summing amp by way of R107, R60, and C9.

The summing amplifier algebraically sums all four of these signals to obtain a composite signal that is sent to the output stage. During startup, a FET, Q1 is turned on slowly so that the servo has time to stabilize in a controlled manner. Also, when an error condition is sensed, an analog switch, U15C, is shorted across this amplifier, thereby opening the loop and shorting the signal being sent to the output stage to ground. During mirror alignment the gain of the summing amplifier is reduced by two orders of magnitude which drastically lowers the loop gain. This allows the customer to align the mirror manually without the servo going unstable. This is explained further in the mirror alignment section in appendix 6.0.

3.7.2. Class 0

Our class 0 servo consists of the following circuits: a position differentiator, an error amplifier, a current integrator, and a summing amplifier. The transfer function can be characterized by the following differential equation:

$$V(t) = A1 * \frac{d(V_{pos}(t))}{dt} + A2 * Error(t) + A3 * \int I(t)dt$$

where:

$V(t)$ = output of summing amplifier

$A1 - A3$ = coefficients that are adjusted with the tuning pots R25, R28, and R59.

$Error(t)$ = the error signal generated as the difference between the position signal, V_p , and the output of the slew rate limiter (command signal).

$I(t)$ = the current flowing through the rotor coil.

The position differentiator takes the first derivative of the position signal to yield angular velocity. This velocity signal is one of two sources of damping for the servo. Its -3db bandwidth is set relatively low. This is to prevent high frequency noise, present on any differentiated signal, from entering the summing amplifier. Its contribution to the servo is to provide damping at low frequency and is controlled by R25.

The error amplifier compares the actual position to the commanded position and generates a signal proportional to this error. Since this is not an integrated signal, the bandwidth of this stage is much higher. Thus, the closed-loop bandwidth of the servo is also higher. The sacrifice is that if there is any friction or spring present, there will be some DC error. However, since Cambridge Technology's scanners have very low friction and no torsion bar, this error is quite small. The contribution of this amplifier to the servo response is controlled by R28.

The current integrator produces a signal proportional to the integral of the current flowing through the rotor. Since the current flowing through the rotor is proportional to the torque produced, it is also proportional to the angular acceleration. Thus, the integral of current can be

used as another source of velocity information, hence damping. The advantage of this form of damping is its inherent low noise. Its bandwidth can be set high without degrading its signal to noise ratio. The overall bandwidth of the system can be extended much further than with position differentiation alone. The current integrator is considered the high frequency damping source and is adjusted with R59.

The summing amplifier algebraically sums all four of these signals to obtain a composite signal that is sent to the output stage. During startup, a FET, Q1 is turned on slowly so that the servo has time to stabilize in a controlled manner. Also, when an error condition is sensed, an analog switch, U7, is shorted across this amplifier, thereby opening the loop and shorting the signal being sent to the output stage to ground. During mirror alignment the gain of the summing amplifier is reduced by two orders of magnitude which drastically lowers the loop gain. This allows the user to align the mirror manually without the servo going unstable. This is explained further in the mirror alignment section in appendix 6.0.

3.8. Output Amplifier

3.8.1 Overview

The output stage uses a power op-amp to supply the large currents used to create torque in the motor coil. A current feedback loop is tied around this output amplifier allowing the summing amp to control the current in the scanner directly. Thus changes in cable length, coil resistance, contact resistance, back EMF voltages, etc. do not affect the summing amplifier's ability to control the torque produced in the scanner. This produces a very stable and repeatable system response with time and temperature.

Current flowing through the motor coil is detected by a low resistance current shunt, R52 and differentially detected by the current monitor U4D. The current monitor signal is then used to close the current feedback loop around the output op-amp U5. It is also used for the "coil temperature calculator" to monitor coil heating and by the current integrator to obtain a velocity signal. The current monitor signal is monitored on TP3. Use TP2 or W7.2 for the ground reference. The current monitor gain varies depending on which scanner is being driven. Check the scanner data sheet for the maximum rms current the scanner can maintain.

The bandwidth of the output stage is mainly controlled with a lead in the current feedback loop. The series/parallel combination of R50 and C8 and R49 in the current monitor's feedback path provides this lead. This RC combination is set so that the output current waveform is adequately damped when a square wave is fed in. Secondary bandwidth limiting is provided via the "noise gain" compensation technique with R40. For large mirror loads, a notch filter module is used to stabilize large inertia systems that tend to "sing" or resonate at the system's torsional resonant frequency. See section 6.2 for more information regarding Notch Filters.

3.8.2. Output Stage Disable

The output amplifier is disabled during the power up sequence and recovery from a fault condition. See sections 3.11 and 3.13 for details. The output amp can also be manually disabled by grounding the TP4 "MUTE" test-point, or the Remote Shutdown input on J4.6. Grounding the Remote Shutdown input will disable the output amp by initiating a continuous fault recovery sequence, but grounding TP4 will not. Therefore, TP4 is useful for performing Notch Filter Module tuning (see section 6.2).

For added motor protection a fuse F1 has been placed in-line with the output op-amp U5. See the motor specifications for the proper fuse rating to be used with each servo configuration. To monitor the voltage signal being sent to the scanner, clip a scope probe to one side of the fuse. Use TP2 or W7.2 for the ground reference.

3.9. Reference Voltages

A voltage reference, U17 (LT1021-5), provides +5 volts for the overposition monitor, Command Offset control, coil temperature calculator, and the DAC references. It is also converted to -5 volts through an inverting amplifier, U16B. The -5 volts is used in the AGC circuit, overposition monitor, and the DAC references. The +/-5 volts used for these various functions are labeled +/-VREF, so that they are not confused with the +5 volts used to power the digital circuitry. The two reference voltages are available on W7.1 (+VREF) and W7.3 (-VREF) for external use provided that no more than 2ma current is drawn from either of them. W7.2 is the ground reference for these voltages.

3.10. Notch Filter Socket

The 670 Board is ready to accept a 6740-XX series Notch Filter Module (NFM). This module is inserted into the J5 socket. If the NFM is not used, then pins 1 & 2 of the socket must be shorted together. See appendix 6.2 for information regarding the use of the 6740-XX NFM.

3.11. Observation/Control Header

3.11.1 User Outputs

Various observation and control signals exist on J4. They are listed below:

J4.1 – Velocity out

Time derivative of position out signal (1K ohm output impedance).

$$\text{Velocity Out} = (\delta V_{\text{pos}}(t)/\delta t) * R100 * C33$$

J4.2 – Position out

Position out signal (1K ohm output impedance). Position Out = $V_{\text{pos}}(t)$

J4.3 – GND #2

Ground return of bypass capacitors.

J4.4 – Error out

Must have a shorting jumper on W9 1&2 for class 1, W9 2&3 for class 0.

Class 0

Class 1

$\text{Error}(t) = V_{\text{com}}(t) - V_{\text{pos}}(t)$ $\text{Error}(t) = (R_{105} * C_7 / C_{16}) * \{V_{\text{com}}(t) / R_{30} - V_{\text{pos}}(t) / R_{29}\}$

J4.5 – GND #4

Ground return of digital circuits.

J4.6 – 90% max power flag

This is an open collector switch that pulls down to -15v when within 10% of a coil temperature fault shutdown (1K ohm output impedance, 10ma sink capability).

J4.7 – Fault out

This is an open collector switch that pulls down to -15v when the fault detector circuit trips (1K ohm output impedance, 10ma sink capability).

J4.8 – Remote Shutdown input

This input causes the servo to enter a fault mode when grounded.

3.11.2 Remote Shutdown Input

If it is desired to stop the scanner automatically, the “REMOTE SHUTDOWN” input on J4.8 allows the user to do so. This signal disables the output amp and trips the fault detector, when grounded, which stops all scanning action within milliseconds. To shut down the servo, use an open-collector transistor switch capable of sinking at least 1ma to ground J4.8. The transistor should have a minimum VCE breakdown rating of 20v. Use J4.5 as the ground reference. The LED status indicator will be orange during remote shutdown.

****Warning!!** During shutdown the scanner’s position may be anywhere within ~120° optical. If the board’s “fault out” signal is not used to control the laser power or direction, the laser may point in an inappropriate direction when the scanners are shutdown.

When the Remote Shutdown signal is de-activated, the board cycles through a normal turn-on sequence as described above.

3.12. LED Status Indicator

The LED status indicator will visually describe the three states of the servo system as follows:

- Green:** system is in **Normal** operation mode.
- Red:** system is in **Fault** mode.
- Orange:** system is in **Remote Shutdown** mode.

3.13. Protection Circuits

The 670 board has various protection features, some of which have been mentioned above. The primary purpose of this circuitry is to allow the servo to stabilize in a controlled fashion during startup, and to shut down the scanner in a controlled manner should it detect any error conditions that could damage the scanner.

The 670 system has two output signals that allow the user to monitor system status. One is the "FAULT OUT" signal available on the J4.7, and the other is the "90% Max Power Warning" signal available on J4.6. Use J4.5 for the ground return. These are open collector switches that pull down to -15v when active, and have a 1K ohm output impedance. The current sinking capability of these outputs is 10ma. The LED Status Indicator on the board turns red whenever the board is in the fault condition.

3.13.1. Startup Sequence

During a normal startup the fault detector U8 goes into an error or "fault" state. This causes the following:

1. The output amp is disabled via U15A, effectively disconnecting the scanner coil from the servo amp.
2. The summing amplifier gain is reduced by a factor of 100 via U15C and R35, allowing a very small error signal to be sent to the output stage.
3. The "command in" signal is disabled via U15B, reducing the command input to zero.
4. The "fault out" signal on J4.7 is active, and the LED status indicator glows red.

After 1 second, the first stage of U8 resets and following actions occur:

1. The output amp is enabled, allowing current from the output stage to pass through scanner.
2. The summing amplifier is enabled and the FET across it turns off slowly so that the gain in the summing amplifier slowly increases.
3. The "command in" signal is still disabled.
4. The above actions cause the scanner to center itself in a controlled way, but prevents the scanner from being driven while doing so.
5. The "fault out" signal stays active with the status LED red.

After 2 additional seconds (3 seconds from turn-on), the second stage of U8 resets and the following actions occur:

1. The error integrator is enabled via U15D.
2. The "position in" signal is enabled.
3. The scanner will begin to follow the input signal.
4. The "fault out" signal de-activates and the LED turns green.

3.13.2. Error Shutdown

There are several error states that the protection circuitry is designed to detect and guard against. They are:

1. Loss of position detector signal: If the cable is not plugged into the scanner or the servo, or if there is a loss of position detector signal for any reason, the fault detector will see this. Va and Vb have to be above a minimum voltage of 0.96 volts.
2. Position Signal, VP has exceeded +/- 10 volts: There are internal mechanical stops within the scanner that prevent it from spinning a full 360°, however during a fault state, the current must be shut off before the rotor reaches these internal stops. The electronics are set to sense when the scanner has exceeded the maximum legal range, +/-20° mechanical. This is accomplished by comparing the position signal (reduced by a factor of two) to the +VREF and the -VREF levels. If Vpos exceeds either one, the fault detector will sense this over-position and trip. Thus, the position output signal must be kept within +/-10 volts or the servo will fault. On systems whose fieldsize has been set to +/-20° mech., the system may trip whenever the edge of the field is approached (65535 and 0). Caution! Do not let the system stay in this condition indefinitely. The scanner might be damaged.
3. Over-temperature: The coil temperature must be monitored at all times when the scanner is being operated close to its performance limit. On the 670 board this is accomplished by the "Coil Temperature Calculator" circuit. This circuit rectifies the current signal, then performs an I^2/R calculation to determine the power dissipated in the coil. Then, knowing its thermal time constant and thermal conductivity to the case, the temperature can be calculated. The "90% Max Power Warning" output signal on J4.6 will be activated when within 10% of tripping the fault detector. The fault detector will trip and the "fault out" signal on J4.7 will activate whenever the coil temperature reaches its maximum safe operating limit.
4. Loss of power: To ensure protection during "brown-outs", the servo will shut the system down if the Input Power Voltages drop below a preset minimum. During system integration, ensure that the power supplies and the power supply connections can meet the demands of the scanner operated at the performance levels expected for the application. If not, the input voltage will dip, and fault circuitry will activate. This can cause a fault "cycling" to occur.

Do not operate the system under these condition or damage to the scanner may occur. See section 3.2. "Input Power" for a more detailed discussion on this.

3.12. Mirror Alignment Mode

The mirror alignment mode shunt is W5. It allows the user to loosen the mirror screws, align the mirrors, and retighten the mirror screws, without the system going unstable. It does this by lowering the loop gain of the system. When W5 is shorting pins 2 and 3, the system is in the normal operating mode. When the jumper is between pins 1 and 2, the system will center itself and feel somewhat "limp" compared to normal operation. The scanner will not follow any input signals when in class 1 mode.

****Caution!!** If the system is set up for class 0 operation, the scanners will still follow the input signal, but at a much reduced loop gain. Do not operate the scanner in this mode except to align the mirrors. Damage to the system could result and void the warranty. Refer to the tuning procedure in section 6.0 for the mirror alignment procedure.

4.0. Operating Instructions

4.1. Precautions and Warnings

As a standard practice, keep the servo channel, scanner, and mirror together as a matched set. At Cambridge Technology, we have matched all three components and tested them as a system. Mixing and matching systems invalidates all of the calibrations that have been done. If mixing the systems is unavoidable, please follow the entire tuning procedure in section 6.0. to verify proper operation. Failure to do so could degrade the performance of the system or possibly damage the system.

Always make sure the scanner is heatsinked properly before operating it for any length of time. Failure to do so can cause a scanner failure due to overheating. Follow the mounting procedures covered in the scanner's Instruction Manual.

Do not attempt to turn any of the servo adjustment potentiometers on the servo board until the entire tune-up procedure has been read and fully understood! The error protection circuitry may not work if the servo was improperly adjusted, causing damage to the scanner.

The Series 670 Single Axis Mirror Positioning System is a high performance servo/scanner system that requires delicate handling. Do not drop or mishandle the scanner, or damage may result.

Do not operate a scanner without its mirror, or other appropriate load, attached securely to the output shaft (except during mirror alignment). Always ensure the mirror is pushed all the way onto the scanner shaft before tightening. Do not use anything other than medium finger pressure to install a mirror mount onto the shaft. Always tighten the mirror mount screws tightly before switching the system back to normal mode. Operating the scanner without a load may cause the system to go unstable, possibly causing damage to the scanner. Do not change the mirrors in any CTI system without checking the tuning afterwards. The ultimate performance of the system will be greatly reduced.

When operating the system, do not repeatedly slam the scanner into its overposition limits at +/- 20° mechanical. Although the protection circuitry shuts the scanner down effectively, the momentum of the rotor and load will still carry the rotor into the mechanical stop. If done repeatedly, the scanner could be damaged.

If the system was ordered without mirrors, the electronics and scanner are tested with test loads, then the servo is "detuned" as outlined in this procedure. These systems must be retuned by the customer before the system can be operated normally. Please refer to section 6.0. for tuning information.

4.2. First Time Startup

1. Using the connector kit provided with your system, make the connectors for J1 and J3 as appropriate. Do not attach them to the 670 board at this time. After constructing the cables, double-check the wiring to ensure that everything is correct. Applying voltages to the wrong inputs would probably damage the scanner and the servo board which would void the warranty. Check the input power section, 3.3.
2. Check that the jumper configuration of W2 and W3 are correct for the voltages provided at the power supply inputs. Check the input power section, 3.3.
3. Plug the scanner cable, male end, into J2 on the servo board and tighten the locking screws securely.
4. Plug the scanner cable female end into the connector on the scanner and tighten the locking screws securely.

Note: Step 5 is for systems that do not already have the mirrors mounted and aligned.

5. Install the mirror on the shaft of the scanner and tighten securely. Ensure that the mirror's angular swing does not allow it to hit any obstruction (e.g. the table the scanner is sitting on or each other). Also ensure the mirror alignment mode jumper W5 is shorting pins 2 and 3. (Not in alignment mode.)
6. Ensure that power is not being applied to the input power connector, J3 and attach it to the 670 board.
7. If the system is to be driven from an analog input, install the J1 connector as appropriate. If the system is digital, refer to the applicable document for the digital input option used. Ensure W4 is set appropriate for the type of input. Whichever type input is being used, set the input signal so the scanner centers. For analog inputs this is 0.000 volts. For the digital inputs, set them to 32768₁₀. For more information, see the Command Input section 3.6.
8. Turn the power on and observe the scanner shaft. One second after turn-on, the shaft should turn to the centered position. Three seconds after turn-on the scanner will move to the commanded position, which also should be centered for now.
9. Turn the mirror load by the edges very lightly to observe if the servo has "stiffened up." "Stiffening up occurs when the scanner is under proper servo control. The scanner should resist your light efforts to turn it. Do not be alarmed if a whining sound is heard or slight clicking is felt when this attempted. This is the normal operation of the current integrator and can be ignored. These sounds will not be made during normal operation.
10. Hook up an oscilloscope or other voltage meter to the Vp signal at TP1. At this time the voltage should read very nearly 0.0 volts. Use TP2 or W7.2 for the ground reference.

11. For digital signals, input a 30 Hz square wave that spans about 5% of the field. For analog inputs, put in a square wave of about 1V p-p at about 30Hz. For very large scanner/mirror systems, 30Hz may be too fast. For those systems, set the frequency to ~5Hz.
12. The scanner should immediately start moving in response to this input. Check the position out signal or look at the scanner itself and observe that it responds appropriately to the input signal.
13. Gradually, increase the amplitude of the input signal until the Command Input waveform has almost reached $\sim\pm 10$ volts. For systems that have an input and output scale factor = 0.5 volts/ $^\circ$ mechanical, the scanner will just go into shutdown at this point. The amplitude will have to be turned down slightly in order to recover. Don't continuously test this over position shutdown feature because the scanner is stressed unnecessarily.
14. Now, gradually turn up the frequency of the input waveform until the desired frequency has been reached or the output waveform begins attenuating, whichever comes first. The maximum coil temperature may be reached before this point. To recover, turn the frequency down and possibly the amplitude of the input signal, in that order.
15. If appropriate, enter an offset signal into the "Offset In" input. The output waveform should now be the algebraic sum of both the normal and offset inputs.

That is it! If the 670 system has performed all of the above functions, it is functioning properly. The scanner can be made to follow any input waveform as long as the maximum amplitude/maximum speed limitations are not exceeded.

5.0. Limited Warranty

CTI warrants that its products will be free of defects in material and workmanship for a period of one year from the date of shipment. CTI will repair or replace at its expense defective products returned by the Customer under a Return Authorization number issued by CTI. This warranty is void if the product is damaged by "misuse" or "mishandling" by any party not under the control of CTI. Misuse or mishandling will be determined by CTI. Misuse includes use of CTI product with incompatible products resulting in damage to the CTI product. The customer is responsible for charges for returning product for repairs. CTI is responsible for charges for shipping product repaired under warranty back to the customer when CTI is allowed to choose the carrier and level of service. The Customer is responsible for repair charges and all shipping charges for non-warranty repairs. CTI's sole liability for any use of its product, regardless of the operating condition of such product, is limited to repair or replacement of the product. The Customer holds harmless and indemnifies CTI from any and all other claims resulting from the use of CTI products.

6.0. Appendices

6.1. Tune-up procedure

6.1.1. Precautions

Read the following procedure completely before attempting to retune the system. Serious damage to the scanner could result if the servo were improperly adjusted!

****Caution!!** Shut the system down immediately if a resonance occurs. A resonating scanner will make a loud noise that sounds like a buzzer or possibly like a high frequency whine. Do not confuse this with the normal sound the scanner makes while operating. If this occurs while tuning up the system, shut it down immediately. Check to make sure the mirror load is correct for the scanner and is firmly attached. If so, start the tuning procedure over again. This is the only way to ensure the scanner isn't damaged. Contact Cambridge Technology if a resonance condition cannot be resolved.

6.1.2 Overview

For most users, the factory settings on the 670 board will never need adjusting. However, if the user wants to change the mirror load originally used, the system will probably have to be retuned. This procedure is aimed at the user who has an electronics background dealing with servo controlled systems. Do not attempt this procedure if any part of it is not clearly understood.

This procedure explains all of the adjustments that are performed at Cambridge Technology. These include the Notch Filter, Position Output Scale Factor, the AGC Linearity, the Command Input Offset, the Command Input Scale Factor, Closing the Servo Loop, and the Slew Rate Limiter.

The following procedure can be used to tune-up the system completely, or to just "touch up" or verify any one of the adjustments. If the tuning adjustments are to be just verified and/or touched up, do not initialize the tuning pots as it states for a complete tune-up. Otherwise the customer will be forced to perform unnecessary steps, which could possibly reduce the performance of the system, depending on the experience of the adjuster. Call Cambridge Technology if any parts of this procedure are not completely understood.

****Caution!!** Failure to carefully monitor the scanner's position response while adjusting the servo trimpots could result in an uncontrolled resonance which could damage the scanner.

6.1.2.1 The order in which the adjustments should be made are:

- 1) Notch Filter Frequency adjustment (sec. 6.2)
- 2) Command Input and Position Output Scale Factors, Linearity (sec. 6.1.5, 6.1.6)
- 3) Closing the Servo Loop (sec. 6.1.7)
- 4) Slew Rate Limiter adjustment (sec. 6.1.7.1.3)
- 5) Matching X and Y Servo Channels (sec. 6.1.9)

Once the scanner is tuned up, there is a procedure in section 6.1.9 that explains how to match the responses of two servo axis channels. For best X-Y scanner performance for most applications, the responses of both channels should be matched.

6.1.3. Required Tools and Materials

1. Dual trace oscilloscope.
2. Function generator - needs to have a sine and square wave output.
3. Digital voltmeter
4. Hand tools - jeweler's screwdriver flat-tip
5. Clip lead with "micrograbber" ends.

6.1.4. Initial setup

Ensure the power is turned off prior to performing the following steps.

1. Refer to the startup procedure in section 4.2. above. Follow steps 1 -7.
2. To find the location of the test points and the tuning potentiometers or "trimpots", refer to the Outline Drawing, D03457, located in section 6.2.

6.1.4.1. Board Silkscreen Potentiometer Identification

The tuning, scale adjustment, position offset, and linearity potentiometers are indicated with a silkscreen aligned under the respective potentiometer on the bottom of the 670 board. The identification is as follows (left to right on underside of board):

Silkscreen	Ref Des	Description of Potentiometer Function
PS	R13	Position Scale adjustment
LIN	R77	Linearity adjustment
SRL	R78	Slew Rate Limiter adjustment
IS	R51	Input Scale adjustment
PO	R1	Position Offset adjustment
EI	R31	Error Integrator coefficient adjustment
LFD	R25	Low Frequency Damping coefficient adjustment. Also referred to as "Position Differentiator".
SG	R28	Servo Gain coefficient adjustment. Also referred to as "Error Amplifier".
HFD	R59	High Frequency Damping coefficient adjustment. Also referred to as "Current Integrator".
BW	R107	Band Width adjustment for HFD and LFD alignment.

6.1.5. Adjusting the Position Output Scale Factor and the AGC Linearity

The Position Output Scale Factor is precisely adjusted at Cambridge Technology and under normal circumstances never needs adjusting by the customer for the life of the servo board or scanner. If however the customer has changed the scanner originally sent with the servo board, (remember they are matched sets) use the following procedure to verify/adjust this signal.

The most important signal generated on the 670 board is the Position Output, V_p , signal. In order for the servo and the error protection circuitry to work correctly, the V_p signal must be scaled properly. The Position Output Scale Factor is controlled by increasing or decreasing the AGC voltage sent to the scanner's position detector. The Position Output Scale Factor is linearly proportional to this AGC voltage. Thus, changes in the Position Output Scale Factor causes changes in the amount the scanner will move for a given output response from V_p . R13 is used to adjust this AGC signal. This trimpot allows ~10% adjustment range. If the AGC voltage is changed by more than 1% during this adjustment, the tuning of the system must be verified to be sure that it is still set properly. It is always prudent to check the tuning after any adjustment to the Position Output Scale Factor or the Linearity Adjustment.

The Linearity Adjustment is used to improve the linearity of the position detector and position demodulator. By varying the amount that V_a and V_b sums together to create the AGC voltage, the linearity is improved. The intention of this adjustment is to minimize the amount the AGC voltage varies as a function of the angular position of the scanner. Since the Linearity Adjustment and the Position Output Scale Factor adjustments affect each other, they must both be set at the same time.

Note: Do not allow the AGC signal present at TP7 to exceed 11 volts or the AGC circuit may saturate, which would result in improper operation.

****Caution:** In all cases, the position signal, V_p , must always have the ability to exceed +/-10 volts when the scanner shaft is turned to its internal mechanical stops or scanner damage may occur.

6.1.5.1 Closed Loop Method

If the system is already tuned up and verification or "touching up" of the Position Output Scale Factor and Linearity Adjustment are desired, use of this method is allowed. Also, if mixing and matching scanners, this method can be used. A mirror must be mounted on the scanner shaft, or some other means of measuring the scanner's angular position must be employed. By reflecting a laser beam from the mirror to a wall, and using some simple trigonometry, the Position Output Scale Factor can be adjusted with high resolution. The further from the wall, the more accurate this method.

1. Follow steps 1 - 7 in section 4.2. above. Set up the input for analog single ended operation by setting J1 and W4 as indicated in section 3.6.

2. Turn on the power.
3. The system should perform its normal turn-on process as described in section 4.2. above.
4. Adjust the Command Input Offset Adjustment trimpot, R1 to 0.000 volts as measured on R1.2 (wiper). Use TP2 or W7.2 as the ground reference. Center the scanner by inputting a signal into the Command Input so that Position Output voltage reads 0.000 volts as measured at TP1.
5. Reflect a laser beam onto the mirror of the scanner being adjusted. This laser beam should be parallel to the wall and level to the floor before it strikes the mirror on the scanner. Position the scanner body vertically and so that the beam is striking the wall perpendicularly. The scanned beam should be in the same plane as the beam striking the mirror. This is important so that the optical beam deflection angle to mechanical deflection angle relationship is a constant factor of two. Compound angles result in relationships that are not just a factor of two. Mark this location on the wall and label it P1. Measure the length from the mirror to the wall and call this distance L1.
6. Input a sine wave signal that drives the scanner to half of the full peak-to-peak angular swing. Usually an input amplitude of 3.535 volts rms is appropriate. See section 3.6 above for more information on the input scale factor calculation. Use an input frequency of ~30 Hz for most applications. For systems with low system bandwidth, because of very large loads, drop the frequency to ~5Hz. Ensure the input sine wave signal has no DC component, i.e. that the peak positive and negative excursions are equal.
7. Measure the rms voltage on TP1. Call this voltage VP1.
8. Label the endpoints of the scanned line on the wall as P2 and P3. Measure the distance from P2 to P3. Call this distance L2.
9. The Position Output Scale Factor, POSF, is obtained with the following formula:

$$\text{POSF} = (\text{VP1} * 1.414) / ((\text{arctangent}(\text{L2} / \text{L1} / 2)) / 2) \text{ volts}^\circ \text{ mechanical}$$
10. Use R13 to set the POSF to 0.500 volts^o mechanical. Setting it to anything else can damage the scanner.
11. Ensure that the AGC voltage on TP7 never exceeds +11V. If it does, the AGC amplifier may saturate as the scanner ages or temperatures change. The scanner would still operate, but at a profound decrease in positioning stability. If the desired position signal gain cannot be obtained without exceeding +11V, seek technical assistance from Cambridge Technology.
12. Monitor the AGC signal at TP7 on an oscilloscope. AC couple the scope. Set the sensitivity to 10mV/div. Adjust the Linearity Adjustment trimpot R77 to minimize the peak-to-peak excursions of this signal.

13. Repeat steps 4. - 12. above until the desired Position Output Scale Factor and Linearity are obtained simultaneously. This is an iterative process and could take a few cycles through the procedure.
14. Again, it is recommended that the tuning procedure be followed to ensure the system's closed loop response it still properly adjusted.

6.1.5.2. Open Loop Method

If the system has not been tuned or there is some doubt as to state of the tuning, use this method to adjust the Position Output Scale Factor to a coarse level so the system can be tuned. After the system is completely tuned, go back to section 7.1.5.1. and perform the Closed Loop Method for Position Output Scale Factor and Linearity Adjustment.

1. Follow steps 1 - 7 in section 4.2. above. Connect TP4 to ground.
2. Turn on the power.
3. The system should perform its normal turn-on process as described in section 4.2. above except that the scanner will not "stiffen up".

Note: If the scanner shaft position moves outside $\pm 20^\circ$, the system will go into a fault state. During this test, this is not a harmful condition and can be ignored.

4. Adjust the Command Input Offset Adjustment trimpot R1 to 0.000 volts as measured on the wiper of R1. Use TP2 or W7.2 as the ground reference.
5. Reflect a laser beam onto the mirror of the scanner being adjusted. This laser beam should be parallel to the wall and level to the floor before it strikes the mirror on the scanner. Turn the scanner's output shaft so that the Position Output signal, V_p , as measured on TP1 reads as close to 0.000 volts as possible. Simultaneously position the scanner body vertically so that the beam is striking the wall perpendicularly. The scanned beam should be in the same plane as the beam striking the mirror. This is important so that the optical beam deflection angle to mechanical deflection angle relationship is a constant factor of two. Compound angles will result in relationships that are not just a factor of two. Mark the point the laser strikes the wall and label it P1. Measure the distance from the mirror to the wall and call this L1.
6. Move the scanner shaft by hand so that the voltage at TP1 is about +5 volts. Mark the position on the wall and label it P2. Simultaneously measure the voltage at TP1 and label it VP1.
7. Move the scanner by hand so that the voltage at TP1 is about -5 volts. Mark the position on the wall and label it P3. Measure the voltage at TP1 and label it VP2.

8. Measure the distance from P2 to P3. Call this distance L2.
9. The Position Output Scale Factor, POSF, is obtained with the following formula:

$$\text{POSF} = (\text{VP2} - \text{VP1}) / ((\text{arctangent}(\text{L2} / \text{L1} / 2)) / 2)$$

10. Use R13 to set the POSF to 0.500 volts/° mechanical. Setting it to anything else can damage the scanner.
11. Ensure that the AGC voltage on TP7 does not exceed +11V. If it does, the AGC amplifier may saturate as the scanner ages or temperatures change. The scanner would still operate, but at a profound decrease in positioning stability. If the desired position signal gain cannot be obtained without exceeding +11V, seek technical assistance from Cambridge Technology.
12. Again it is recommended that after this procedure has been performed, perform “Closing the Loop” in section 6.1.6., then return to 6.1.5.1. for a more accurate setting of the Position Output Scale Factor and Linearity Adjustment.
13. Turn off the power.
14. Disconnect TP4 from ground.

6.1.6. Command Input Scale Adjustment

Trim-pot R51 allows for fine control of the Command Input Scale Factor. How this affects the overall Command Input Scale Factor is described more thoroughly in sections 3.6.3. and 3.6.5. above.

This procedure describes how to set the voltage gain from the output of the slew rate limiter, U1A.1 with respect to the input at W4. We refer to this ratio as the Slew Rate Limiter Voltage Gain. This gain is almost always set to 1:1. However, R51 can be used to vary this gain from 1.07:1 to 0.82:1.

R51 and R82 can be replaced to extend the range of this adjustment. However, do not let the minimum series resistance from the input of R51 to ground be less than 2 Kohms. Use a high quality potentiometer or excessive drift and/or noise will result.

1. Setup the system by following steps 1 - 7 in section 4.2.
2. Open the servo loop by connecting TP4 to ground
3. Apply power to the system.

4. Apply a stable voltage into the Command Input. For digital input systems, send a 16384_{10} output word to the digital input option, and set up W4 for DI non-inverting. For analog systems use the $-VREF$ signal as a command input by connecting W7.3 as a single ended non-inverting input on W4. For both types, measure this voltage at W4 and record it. Call this VIN1.
5. Measure the voltage at U1A.1 or the input side of R30 and record it. Call it VIN2
6. The Slew Rate Limiter Voltage Gain, SRLVG, is:

$$SRLVG = VIN2 / VIN1$$

7. Use R51 to adjust this ratio to the desired level, usually 1:1.
8. Turn off the power.
9. Disconnect TP4 from ground.

This adjustment can also be performed in a closed-loop manner. If the servo loop is already tuned up, and it is desired to adjust the fieldsize of the system slightly, follow the procedure below.

1. Set up the system by following steps 1 - 7 in section 4.2. above.
2. Input a signal that corresponds to a calculated amount of beam motion. Refer to sections 3.6.3 and 3.6.5 for more information on calculating the Command Input Scale Factor. This input signal can be a DC voltage or a dynamic pattern. For best results, the dynamic pattern should not be moving so quickly that the pattern starts to attenuate or "shrink in size".
3. Adjust R51 so that the desired amount of beam motion is obtained.

6.1.7. Closing the Servo Loop

The following steps will close the servo loop and make all of the servo circuitry active. Again, it is stressed that the following steps be read and understood thoroughly before proceeding!

The purpose of this procedure is to adjust the servo loop trimpots so that the scanner/mirror system yields the fastest critically damped step response to a square wave input. Once this is obtained, the system will yield the best overall performance for any given input waveform. Only tune the system up as fast as is needed for the specific application. Excessive speed or "loop gain" will cause the system to have undesirable resonances which increase settling time.

As mentioned earlier, there are two servo configurations, class 1 and class 0. To determine if your system is set up for class 1 or for class 0, look on the 670 board at jumper W1. If the jumper is connecting pins 2 and 3, the system is set up for class 1. If the jumper is connecting pins 1 and 2, it is set up for class 0 operation. The tune-up procedure for each is different, so each procedure will be discussed separately below.

If it is only desired to verify the system tuning, skip down to section 6.1.7.1.2. or to section 6.1.7.2.2. Do not turn all the pots back to ground or the entire tuning procedure will have to be followed.

6.1.7.1. Class 1

The object of this procedure is to bring the servo gain up slowly so that control of the scanners is maintained at all times. Move all the trimpots in small increments until experience with this system is obtained. If at any time during this procedure the scanners start to move erratically and make a loud buzzing noise, shut off the input power immediately, set all trimpots to zero and restart the procedure.

6.1.7.1.1. Coarse Tuning

1. Perform steps 1 - 7 in section 4.2. above.
2. Initialize the following tuning pots. Turn R25, R28, R31, and R59 counter-clockwise, CCW, at least 15 turns or until they begin to click. Do not touch R107. It has been factory set and should not need adjusting at this time. Turn R78 fully CW 15 turns.
3. Turn R25, R28 and R59 2-3 full turns CW. This should allow both scanners to center themselves with a slight amount of loop gain once the power is applied.
4. Attach a scope probe to the input signal at W4 to monitor the input signal. Use the rising edge of this signal as the trigger source for the scope. Attach another scope probe to TP1 to monitor the Position Output signal, VP. Use TP2 or W7.2 as the ground reference for both signals. Set the vertical gain to 0.2V/div for both channels on the scope.

5. Apply power to the system. The system should perform its normal turn-on sequence and both scanners should center themselves. Check the voltages at TP1 to ensure that the scanners are somewhat near the center of the field. (Within ~1 volt.) If the scanners have not yet centered, turn R25 and R28 CW a little more while carefully watching the oscilloscope for any erratic behavior. Ensure that the servo loop is slightly "stiff" by attempting to move the mirror. Touch the mirror only by the edges to avoid fingerprints. The use of finger cots is highly recommended. When the servo is stiff, the mirror will resist slight efforts to move it, and center again when released. Once this is obtained, continue on to the next step.

****Caution!!** If at this time a load buzzing or whining noise is heard from the scanners, shut off the power immediately. Turn R28 CCW one full turn and try applying power again. If the system is still not behaving well, start over at step 1 again using less turns for the initial adjustment in step 3. above. If the system cannot be made to work, call Cambridge Technology for assistance.

6. Input a square wave signal at a frequency of 30Hz. Set the amplitude to produce about 2° p-p of scanner shaft motion. The exact amount is not important as long as the motion is small.

7. Turn R31 CW very gradually until a waveform similar to figure 1 is obtained. The trimpot will have no effect the first one or two turns, then it will begin to have effect. Continue to turn the trimpot CW until the oscillations just die out before the next half cycle of the input signal.

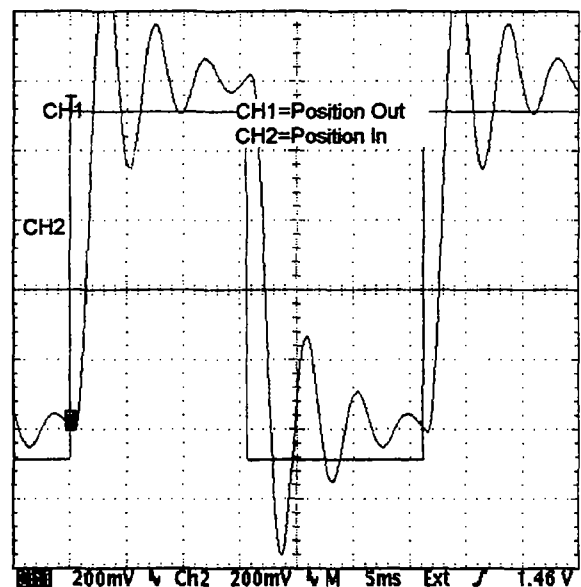

Figure 1.

8. Turn R28 CW until the first overshoot is minimized, i.e. at the same amplitude as the settled position. See Figure 2.
9. Turn R25 CW the first undershoot is minimized, i.e. at the same amplitude as the settled position. See Figure 3.

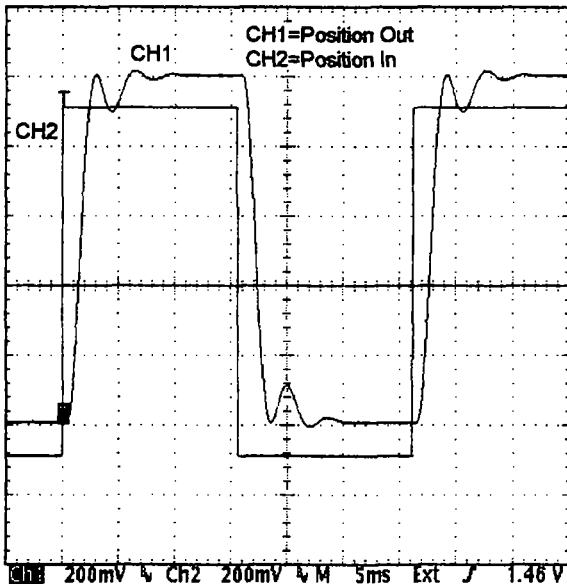

Figure 2.

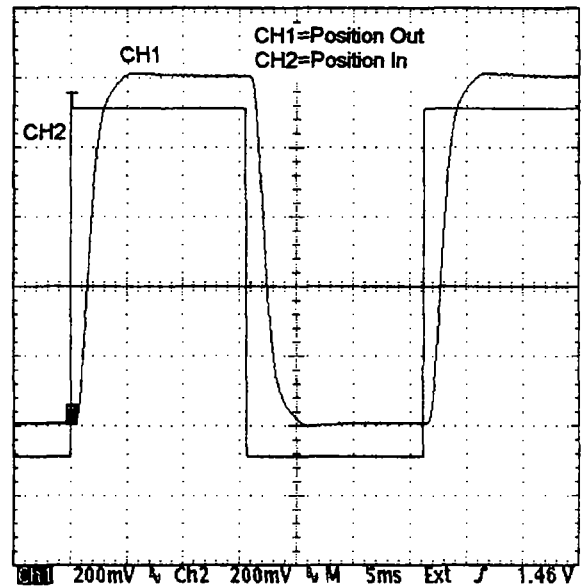

Figure 3.

10. Turn R59 CW until the second overshoot is minimized, i.e. at the same amplitude as the settled position. See Figure 4.

11. Turn R25 CW until the undershoot is minimized. See Figure 5.

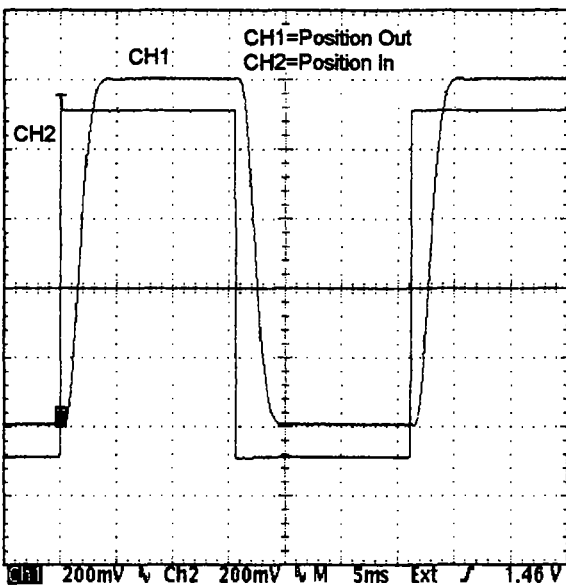

Figure 4.

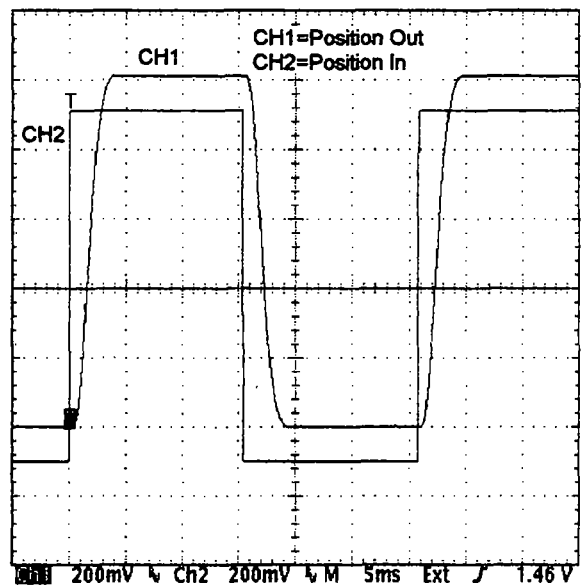

Figure 5.

12. Turn R28 until the first overshoot is minimized. See Figure 6.

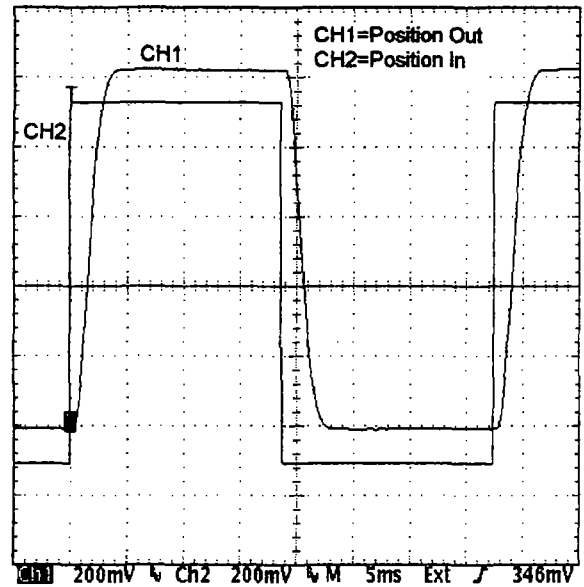

Figure 6.

13. To increase the speed of the system (decrease the step response time) still further, slowly turn R31 CW a few more turns, then re-tweak the other trimpots as before to make the waveform look critically damped again. This can be continued until the desired small-angle step response time is obtained or the system begins to resonate or “ring”. If this ringing occurs, immediately turn back the trimpots starting with R31, then R28, then R25, and then R59 until this stops. Turn each trimpot CCW gradually and evenly, similar to when the loop gain was increased. Do not operate the system with the loop gain turned up so high that the servo rings anywhere in the field. Experience with the system will determine how fast it should be tuned. Call Cambridge Technology Inc. for more information on this subject. Refer to figure #7 for how the waveform should appear after iterating through the above steps.

Note the critical damping in figure 7. There is no appreciable overshoot nor undershoot. The step response for this scanner/servo system is about 2msec. The scanner is considered settled when the position signal has settled to within about 1% of the length of the step. The exact step response time will vary from system to system depending on load dynamics and scanner size.

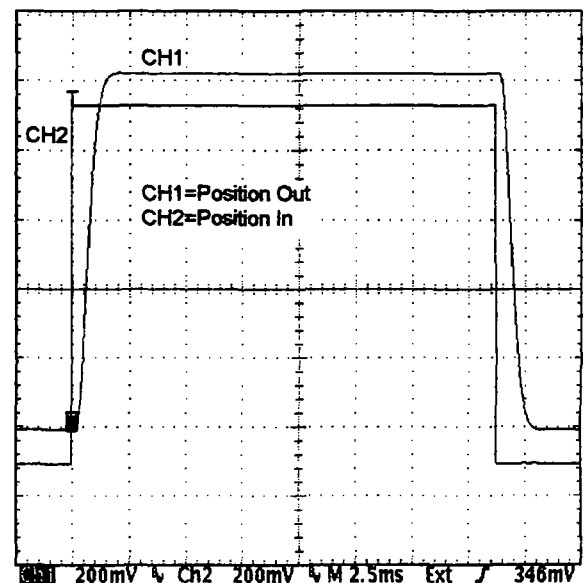

Figure 7.

6.1.7.1.2. Fine Tuning

The purpose of this section is to adjust more carefully the “shoulder” of the step response.

1. Setup the system by performing steps 1, 4, and 6 from section 6.1.7.1.1. above.
2. Turn on the system power.
3. Adjust the input signal amplitude and offset so that the scanner now steps from -2.0° to 0.0° in a square wave fashion and at the same frequency as before.
4. Adjust the oscilloscope channel monitoring V_p to 10mV/div. The system should now look like Figure 8.

Note: Since only the coarse tuning has been performed thus far, your waveform may look slightly different at this point. However, the same tuning rules still apply.

5. Turn R28 CCW to bring the first overshoot at the same level as the settled waveform. See figure 9.

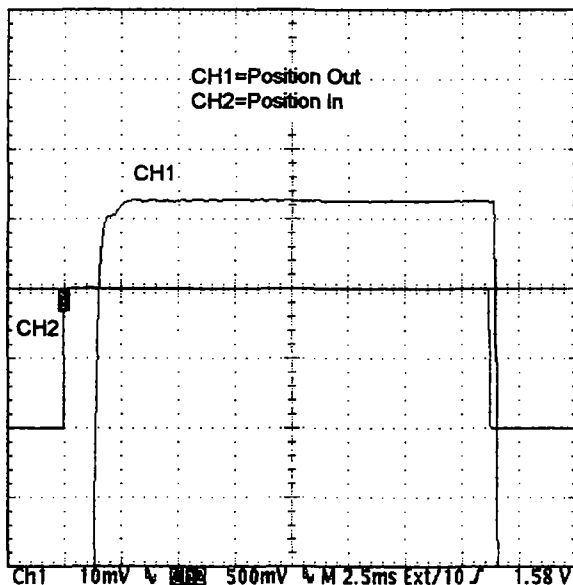

Figure 8.

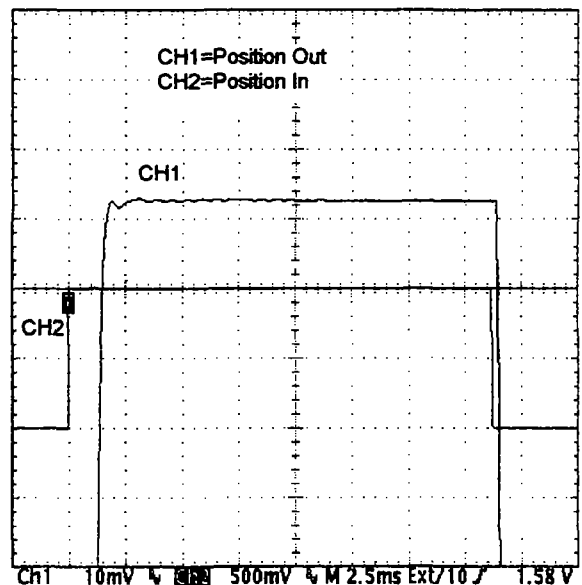

Figure 9.

6. Turn R25 CW to eliminate the first undershoot. See Figure 10.

7. Turn R59 CW to eliminate the second overshoot. See Figure 11. This will make the first overshoot much larger. This will be corrected by R28 in the next step.

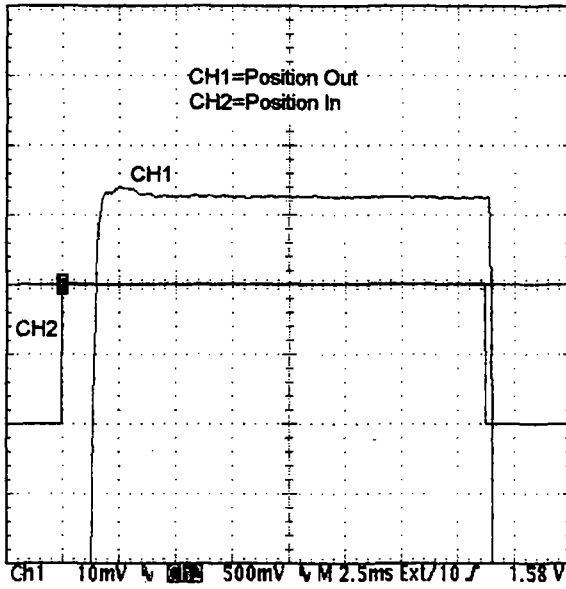

Figure 10.

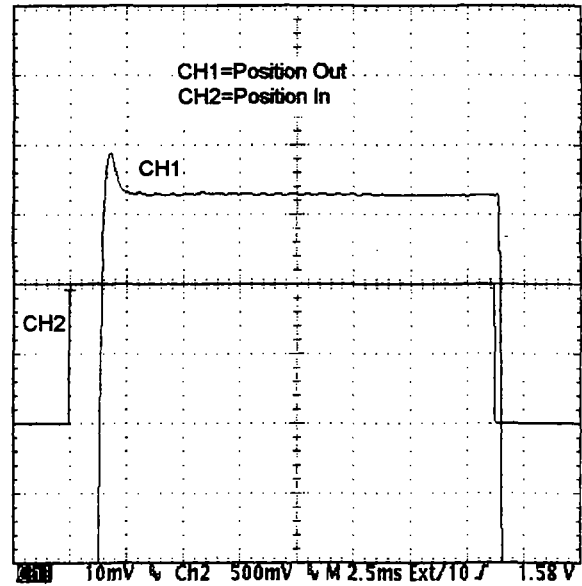

Figure 11.

8. Turn R28 CW to eliminate the first overshoot. See figure 12.
9. Iterate steps 6, 7 and 8 until the system settles as well as possible. See Figures 13. and 14.

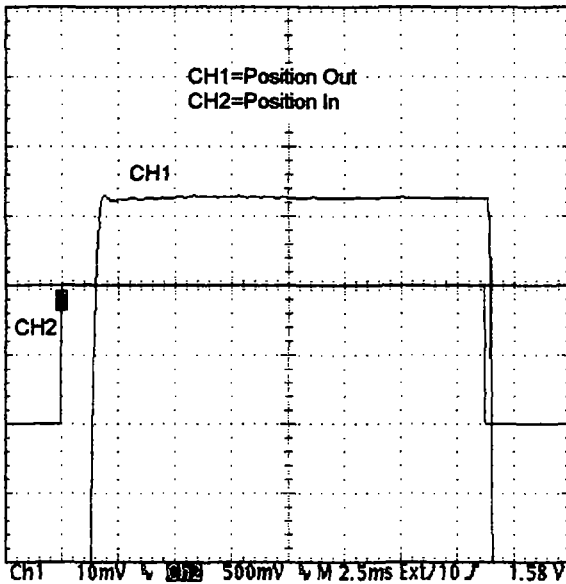

Figure 12.

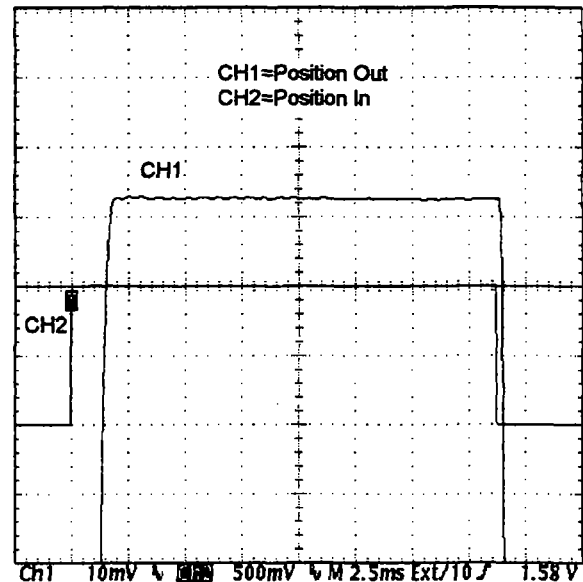
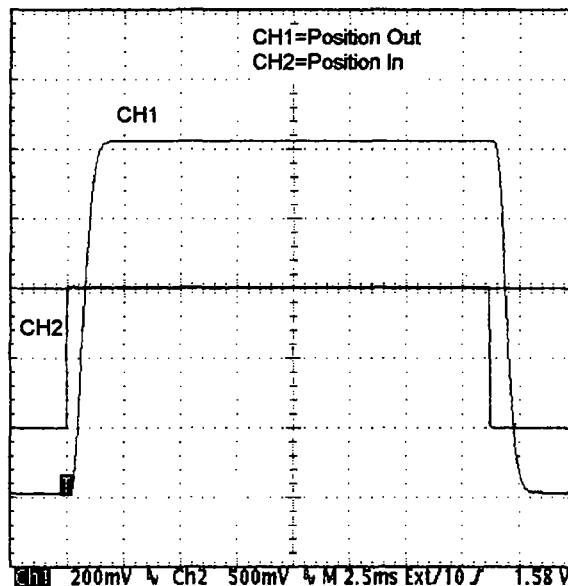

Figure 13.

Note: Whenever the small angle step response is changed, the large angle step response should be checked in the Slew Rate Limiter Speed Adjustment section 6.1.7.1.3.

Figure 14.



6.1.7.1.3. Slew Rate Limiter Speed Adjustment

Now that the small angle step response is set, the Slew Rate Limiter Speed Adjustment can be set to control the large angle response. The purpose of this adjustment is to keep the output stage of the servo from saturating for the largest and fastest possible move to be performed in the application. This is usually a full-field square wave.

****Caution!!** Ensure the scanner is properly heatsinked or damage to the scanner will result.

1. Set up the system as in section 6.1.7.1.1. above.
2. Using a square wave input, adjust the frequency of the input waveform so that the motor will have enough time to settle at each point before the next half cycle of the square wave occurs. If that is not yet known, run the system at around 30 Hz. Note: For very large inertia systems this might be too fast, thus a slower frequency will have to be used.
3. Set the amplitude of the input waveform so that the scanner moves symmetrically about 1.0 volts p-p centered around 0.0 volts.
4. Attach one scope probe to Position Out on TP1. Set the scope channel's sensitivity to 0.5V/div. Attach a second scope probe to F1 to the +Motor signal. Set the sensitivity to 10V/div. This is the drive voltage sent to the scanner drive coil. See Figure 15.
5. Increase the amplitude of the input signal slowly while watching the +Motor signal on the scope.

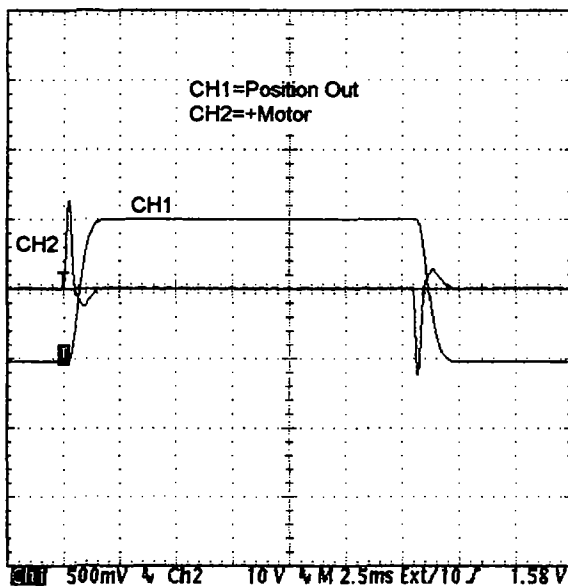

Figure 15.

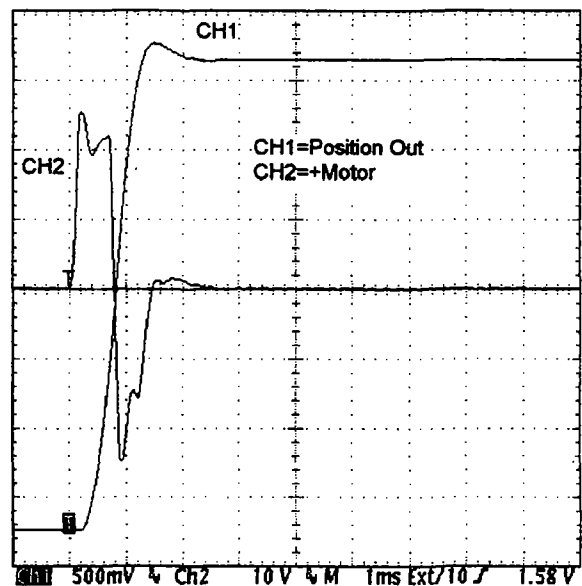

Figure 16.

6. As needed, adjust the Slew Rate Limiter Adjustment trimpot, R78, CW to slow the maximum slew rate of this large angle square wave as needed to keep the +Motor voltage from “squaring off” or saturating at the top of the first peak. Figure 16 shows this squaring off phenomenon. Slowing down the input signal will increase the large-angle step response time. However, the best settling performance will be achieved when the output amplifier is not allowed to saturate. To ensure the output amplifier will not saturate even after the scanner reaches its maximum operating temperature, use the following formula for setting the maximum voltage on +Motor during the step:

$$+Motor\ peak = (+Drive - 2V) / 1.3 \quad \text{where: } +Drive = \text{Input power to the servo card}$$

Note: In the example above, the +Drive = +28V, thus +Motor peak = 20V.

Depending upon motor impedance, load inertia, system tuning, power supply voltages, etc., the max output amplifier current of +/- 10A may be reached prior to voltage saturation.

Keep turning R78 until the +Motor peak is at the desired level as given by the above formula. See figure 17.

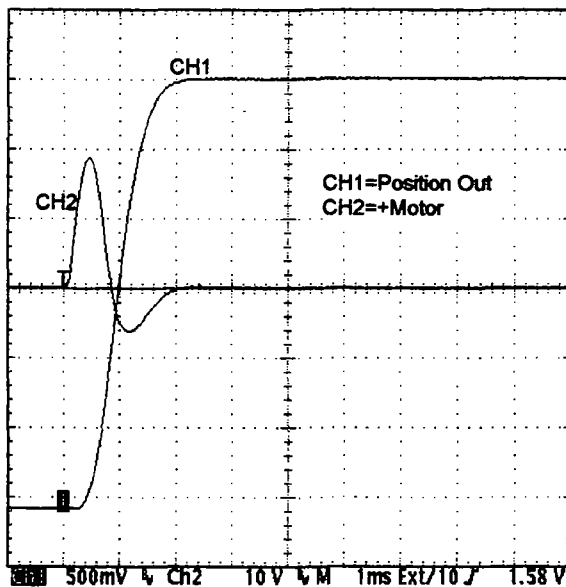

Figure 17.

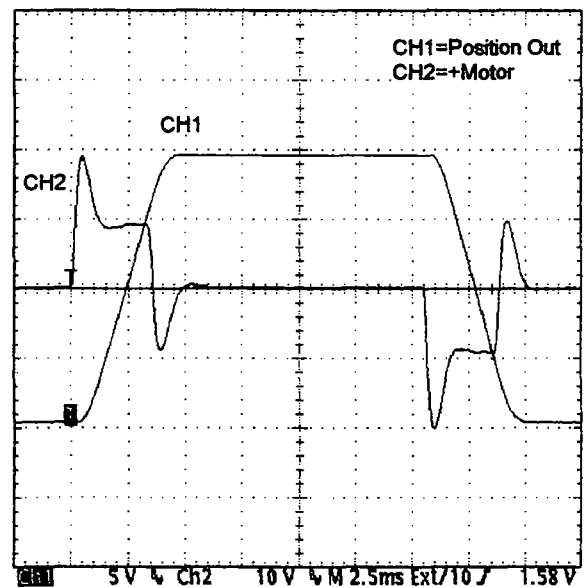

Figure18.

7. Iterate steps 5 and 6 until the maximum angle for the system configuration is reached. See Figure 18.

If the Command Input Scale Factor is set so that the fieldsize of the system is less than the full +/-20° mechanical, then the position output, Vp, will not travel the whole +/-10volts. Since the slew rate limiter sometimes affects the small angle response slightly, go back to section 6.1.7.1.2. to check that it the system is still critically damped.

6.1.7.2 Class 0

The object of this procedure is to bring the servo gain up slowly while maintaining control of the scanners at all times. Move all the trim pots in small increments until experience with this system is obtained. If at any time during this procedure the scanners start to move erratically and make a loud buzzing noise, shut off the input power immediately and check the procedure to see if all steps were followed properly.

6.1.7.2.1. Coarse Tuning

1. Perform steps 1 - 7 in section 4.2. above.
 2. Initialize all tuning pots. Turn R25, R28, R31 and R59 counter-clockwise, CCW, at least 15 turns or until they begin to click. Do not touch R107. It has been factory set and should not need adjusting at this time. Turn R78 fully CCW 15 turns. Ensure W1 and W6 are connecting pins 1 and 2.
 3. Turn R25, R28 and R59 2-3 full turns CW. This should allow the scanner to center with a slight amount of loop gain once the power is applied. It also allows the input signal to pass through the system, so be careful when turning on power in step 5 below. Ensure the input signal is set to a DC voltage of 0.0volts.
 4. Attach a scope probe to the input signal at W4 to monitor the input signal. Use the rising edge of this signal as the trigger source for the scope. Attach another scope probe to TP1 to monitor the Position Output signal, VP. Use TP2 or W7.2 as the ground reference for both signals. Set the vertical gain to 0.2V/div for both channels on the scope.
 5. Apply power to the system. The system should perform its normal turn-on sequence and both scanners should center themselves. Check the voltage at TP1 to ensure that the scanner is somewhat near the center of the field. (Within ~1 volt.) If the scanner has not yet centered, turn R25 and R28 CW a little more while carefully watching the oscilloscope for any erratic behavior. Ensure that the servo loop is slightly "stiff" by attempting to move the mirror. Touch the mirror only by the edges to avoid fingerprints. The use of finger cots is highly recommended. When the servo is stiff, the mirror will resist slight efforts to move it, and center again when released. Once this is obtained, continue on to the next step.
- **Caution!!** If at this time a load buzzing or whining noise is heard from the scanners, shut off the power immediately. Turn R28 CCW one full turn and try applying power again. If the system is still not behaving well, start over at step 1, using less turns for step 3. If the system cannot be made to work, call Cambridge Technology for assistance.
6. Input a square wave input signal at a frequency of 30Hz. Set the amplitude to produce about 2° p-p of scanner shaft motion. The exact amount is not important as long as the motion is small.

7. The scanner should now be responding to the input waveform, but should look very underdamped. Continue to turn R28 CW until the oscillations just die out before the next half cycle of the input signal. See figure 19.
8. Turn R25 CW to minimize the first overshoot and to minimize the oscillations. See figure 20.

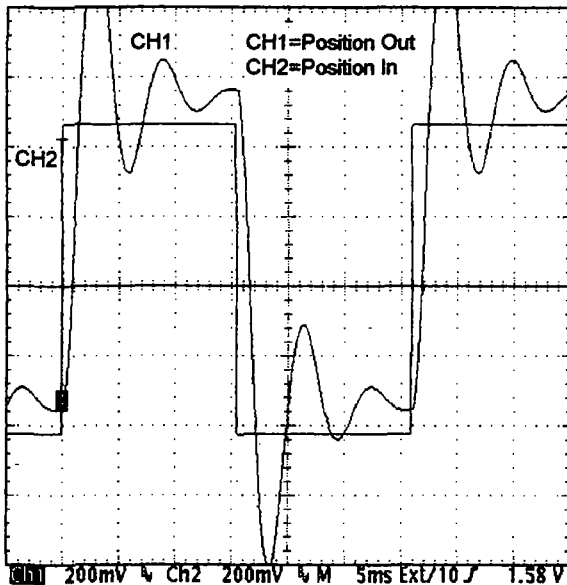

Figure 19.

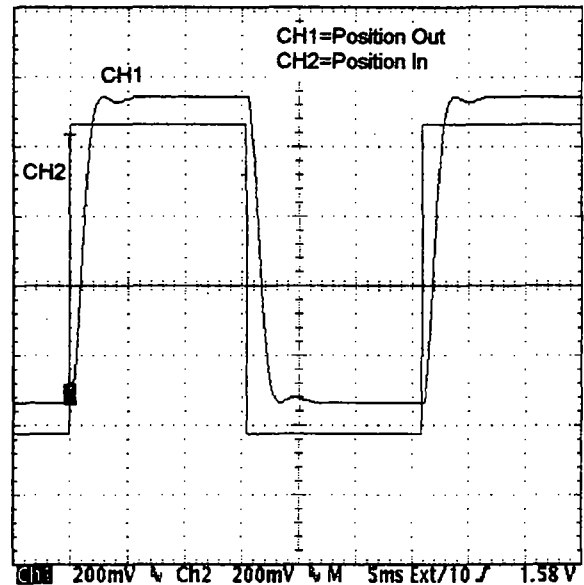

Figure 20.

9. Turn R59 CW until the undershoot is minimized, i.e. at the same amplitude as the settled position. See Figure 21.
10. Turn R25 CW until the first overshoot is minimized, i.e. at the same amplitude as the settled position. See Figure 22.

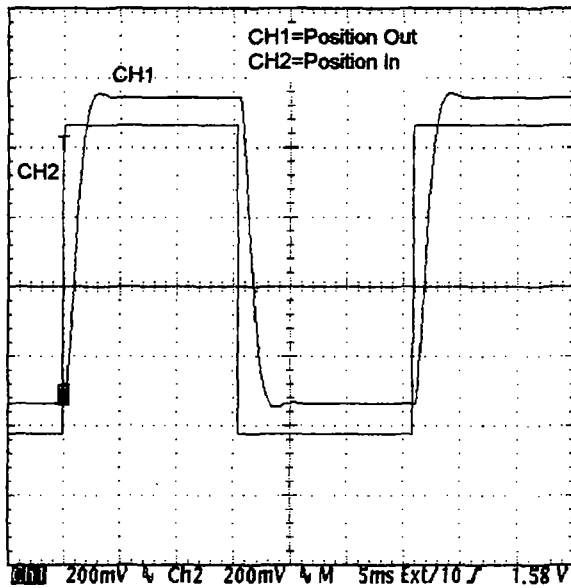

Figure 21.

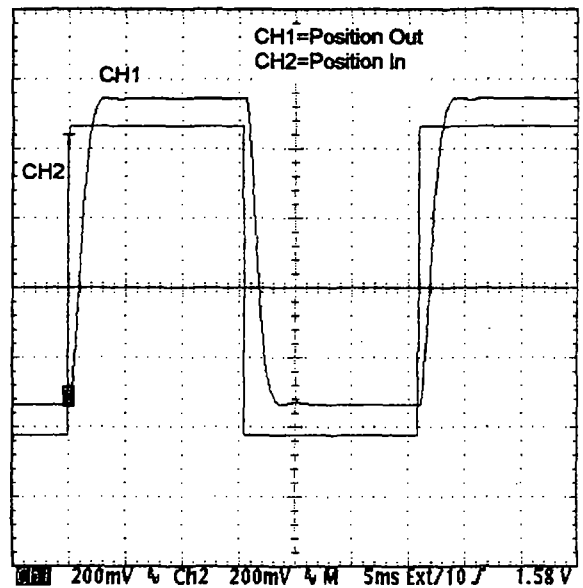
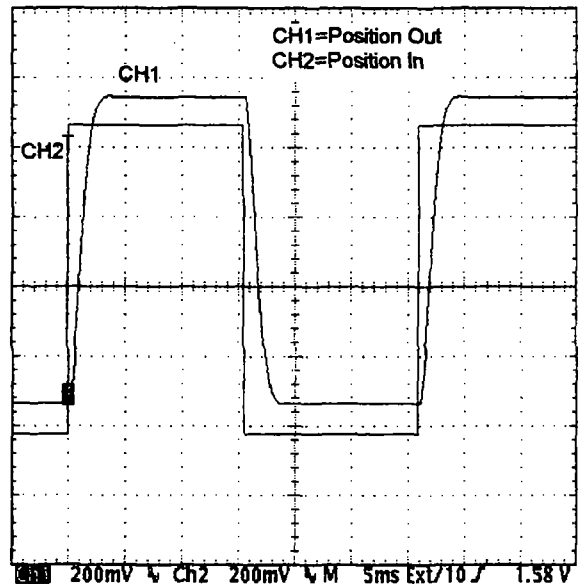

Figure 22.

11. Iterate steps 9 and 10 above until the waveform is critically damped as shown in figure 23.

Figure 23.



12. To increase the speed of the system (decrease the step response time) still further, slowly turn R28 CW a few more turns, then re-tweak the other trim pots as

before to make the waveform look critically damped again. This can be done until the desired small-angle step response time is obtained or the system begins to resonate or “ring”. If this ringing occurs, immediately turn back the trim pots starting with R28, then R25 and then R59 until this stops. Turn each trim pot CCW gradually and evenly, similar to when the loop gain was increased. Do not operate the system with the loop gain turned up so high that the servo rings anywhere in the field. Experience with the system will determine how fast it should be tuned. Call Cambridge Technology Inc. for more information on this subject. Refer to figure 24 for proper tuning after iterating through the above steps.

Note the critical damping in figure 24. There is no appreciable overshoot nor undershoot. The step response for this scanner/servo system is about 1.25msec. The scanner is considered settled when the position signal has settled to within about 1% of the length of the step. The exact step response time will vary from system to system depending on load dynamics and scanner size.

Figure 24.

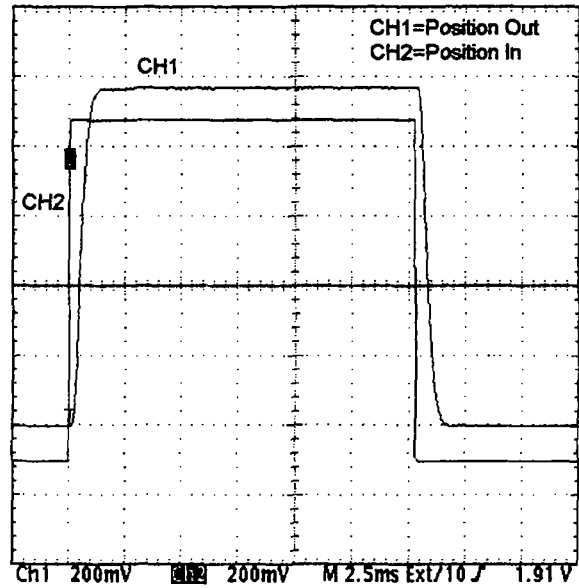

6.1.7.2.2. Fine Tuning

1. Setup the system by performing steps 1, 4, and 6 from section 6.1.7.2.1. above.
2. Turn on the system power.
3. Adjust the input signal amplitude and offset so that the scanner now steps from -2.0° to 0.0° in a square wave fashion and at the same frequency as before.
4. Adjust the oscilloscope channel monitoring V_p to 10mV/div. The system should now look like Figure 25.

Note: Since only the coarse tuning has been performed thus far, your waveform may look slightly different at this point. However, the same tuning rules still apply.

5. Turn R59 CW to minimize the amplitude of the undershoot as shown in Figure 26.

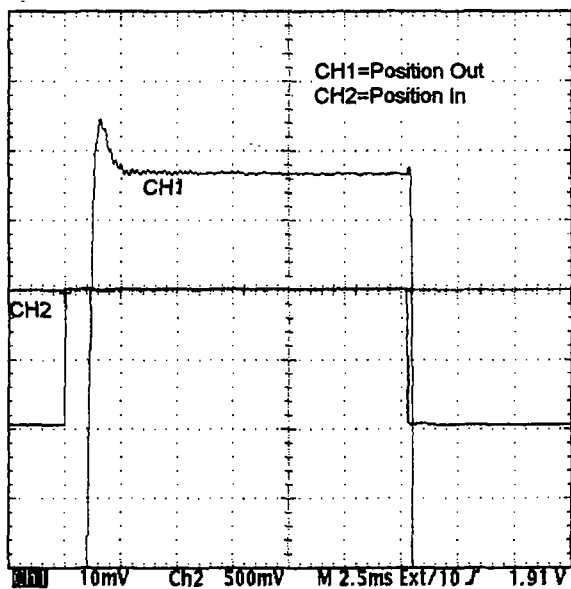

Figure 25

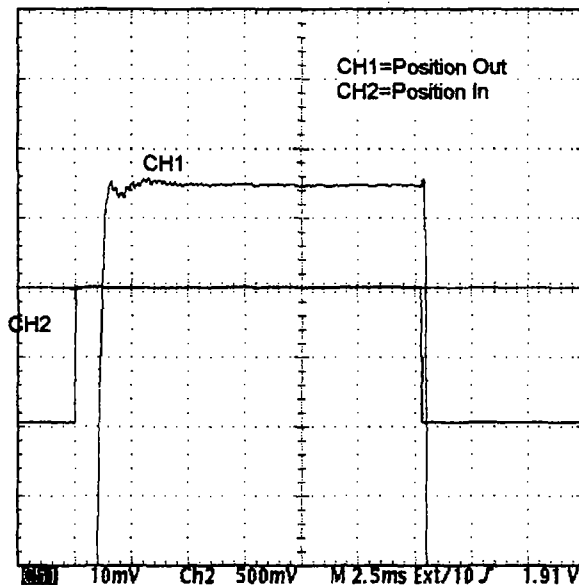

Figure 26

6. Turn R25 CW to eliminate the overshoot. See Figure 27.
7. Iterate steps 5 and 6 until the system settles as well as possible. See figures 28 and 29.

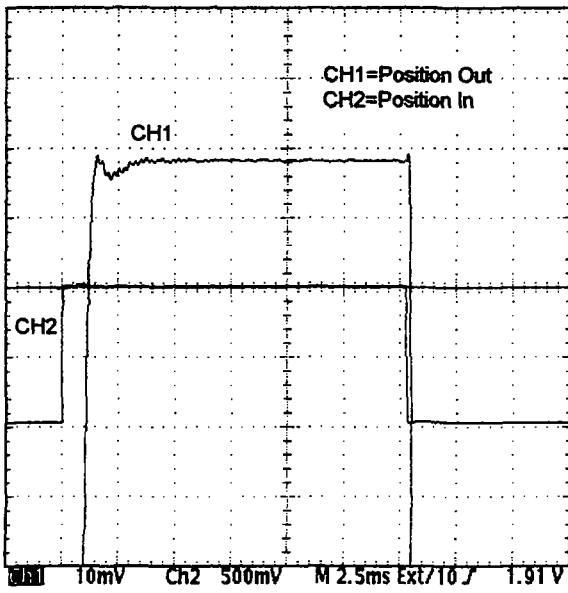

Figure 27.

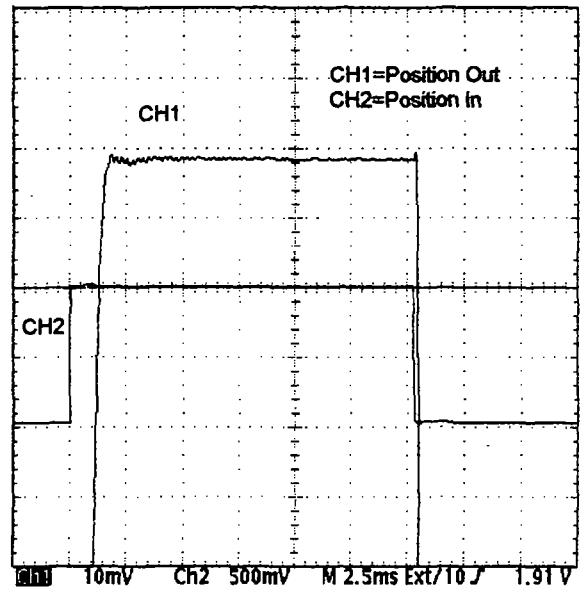
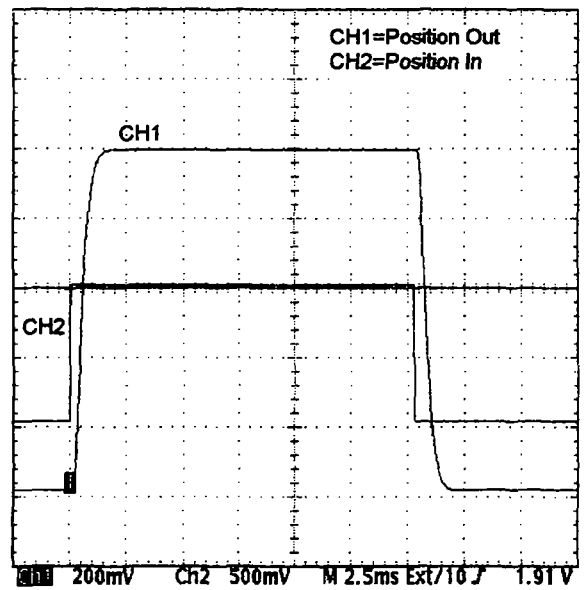

Figure 28.

Note: Whenever the small angle step response is changed, the large angle step response should be checked in the Slew Rate Limiter Speed Adjustment section 6.1.7.1.3.

Figure 29.



6.1.8. Aligning the Mirror

This procedure describes how to align the scanner mirror (load) while the servo is still active. Since the servo normally interprets someone holding or touching the mirror as a change in the inertia of the mirror, the system usually goes unstable. The Mirror Alignment Mode jumper, W5, when activated, lowers the loop gain, allowing the user to loosen the mirrors while the servo is still active, but without it going unstable.

Note: This procedure can only be used to align the mirror to the center of its range. It cannot be used to align the mirrors to some other point in the field. The Mirror Alignment Mode jumper forces the scanner to go to the centered position.

1. Setup the system by following steps 1 - 7 in section 4.2. above. The system must have had the Position Output Scale Factor, the Command Input Scale Factor, and the Closed Loop Response already adjusted properly either by CTI, or by the above procedures.
2. Send a digital 32768_{10} to both channels for digital inputs, or send a 0.000 volt signal for analog inputs. Ensure the Command Input Offset trimpot R1 is set to 0.000 volts by monitoring on the wiper of R1.
3. Remove the jumper, W5, from connecting pins 2 and 3, and re-insert it onto pins 1 and 2. The system is now set up in Mirror Alignment Mode.
4. Turn the power on. The system should turn on in the normal sequence, except the mirrors will stay at the center position.
5. The mirror mount clamp screws can now be loosened.
6. Referring to the proper XY Mount Interface Dwg in section 6.2. locate the entrance and exit points for the mount.
7. Align a laser beam so that it enters the entrance pupil perpendicularly to that side of the mount. Make sure it is perpendicular in both the vertical and horizontal axes.
8. Place a target some distance from the mount to capture the exiting beam. Position the target so that a beam exiting the XY mount is at the exit pupil and perpendicular to the entering beam.
9. Adjust the mirrors in the XY mount so that the exiting beam strikes the center of the target.
10. Make sure the mirrors are pushed all the way down the shaft. Tighten the screws securely, but not so tight as to strip out the small Allen heads.
11. Re-install W5 back to its Normal Mode location, connecting pins 2 and 3. Ensure the position of the beam is still centered.

Note: There may be a small offset in position from Mirror Alignment Mode to Normal Mode. This is due to any friction and/or spring in the scanner and because of the reduced loop gain. To account for this, offset the mirror the same amount but in the opposite direction of the original offset. This can be done because this offset is most often very repeatable.

6.1.9. Matching Two Servo (X and Y) Channels

The purpose of this section is to match the dynamic performances of a dual axis X and Y system over all angles and frequencies. This system would consist of two 670 boards and two scanners. If the two channels are not closely matched, the system will not make straight lines when both channels are moved simultaneously. They also will not retrace a pattern when the beam is traveling in the opposite direction. Thus, it is crucial for optimum performance to perform this procedure whenever either servo channel has been retuned. This matching is done standard at Cambridge Technology and should not need to be repeated during the normal operating life of the system.

1. Set up the system by following steps 1 - 7 in section 4.2. The system must have had its Command Input Scale Factor, Position Output Scale Factor, and Closed Loop Response adjusted properly to perform this. Ensure the mirrors are aligned by following the procedure in section 7.1.8., to eliminate the chance of their hitting.
2. Input a 30 Hz square wave signal such that the scanners move 2° mechanical peak-to-peak. For larger systems a slower square wave can be used. It is very important that the two channels receive the information simultaneously, or this procedure cannot be performed properly. For analog input systems, this is easily done by using a BNC "T" connector and hooking up to both inputs simultaneously. If the system is digital, do not let a timing skew occur between the X and Y channels. Let both channels' CS lines go low simultaneously. If this is not possible, convert the 670 for analog input operation for the purpose of this procedure.
3. Turn on the system power. Monitor both channels' position out signals, Vp on TP1, on an oscilloscope while externally triggering the scope on the input signal at W4. Monitor the channel with the greater inertia first. This is usually the slower system. In most cases this is the Y-channel. Ensure the step response is at the required speed for the application and that it looks critically damped. Refer to the tuning procedure above in section 7.1.7. for specific instructions. If it is not tuned as required, retune this channel now.
4. Input a full-field signal. Monitor the same channel and ensure that the large signal step response is also as desired. Once this is accepted, do not turn any of the pots associated with this channel or this procedure must be started over again.
5. Input a 2° signal again. Now monitor both channels' Position Out signals superimposed on one another on the oscilloscope. Increase the vertical gain and sweep speed on the oscilloscope until the speed difference between the two channels is noticeable. See Figures 30 and 31.

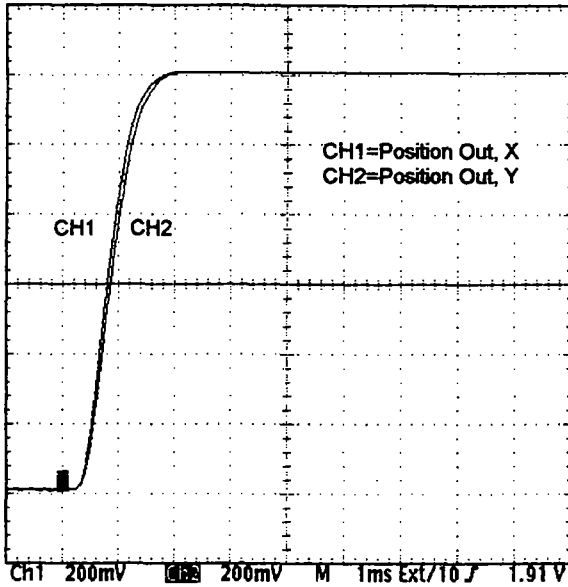

Figure 30.

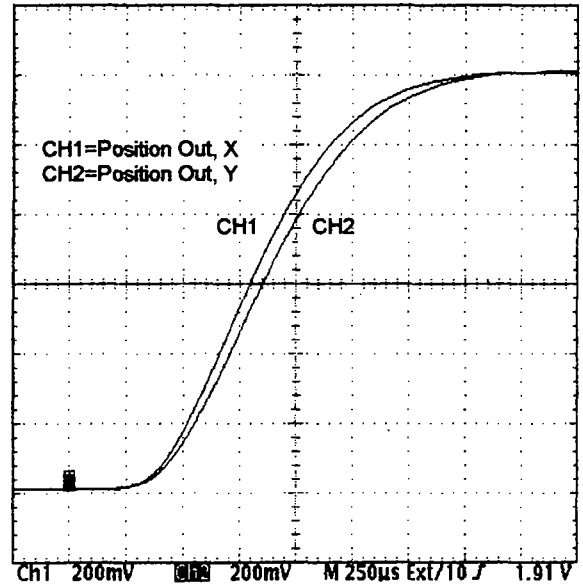

Figure 31.

6. Slow the faster servo channel as necessary by adjusting its servo adjustment trimpots slightly. Refer to section 6.1.7. for proper operation of all the tuning trimpots. Ensure that the channel is still critically damped when done. Do not adjust this channel's slew rate limiter trimpot at this time. Be patient. The faster channel should be slowed to track the first almost perfectly. When done, the system should look like Figures 32 and 33.

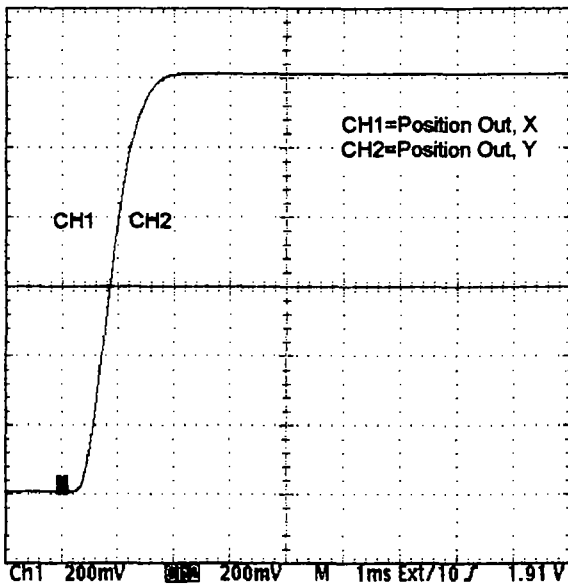

Figure 32.

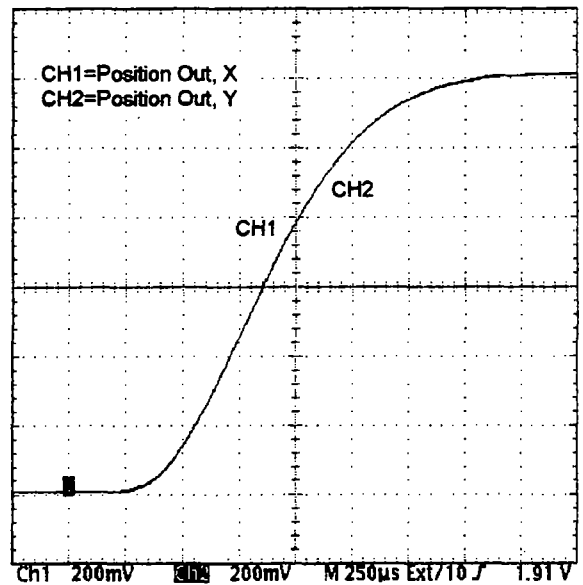

Figure 33.

7. Input a full-field signal. See figure 34. While monitoring both channels, slow the faster channel's slew rate limiter trimpot, R78 to make the signals are equally fast. When done, the system should look like Figure and 35.
8. Repeat steps 6 and 7 until both conditions can be met and the outputs look like figures 32, 33, and 35.

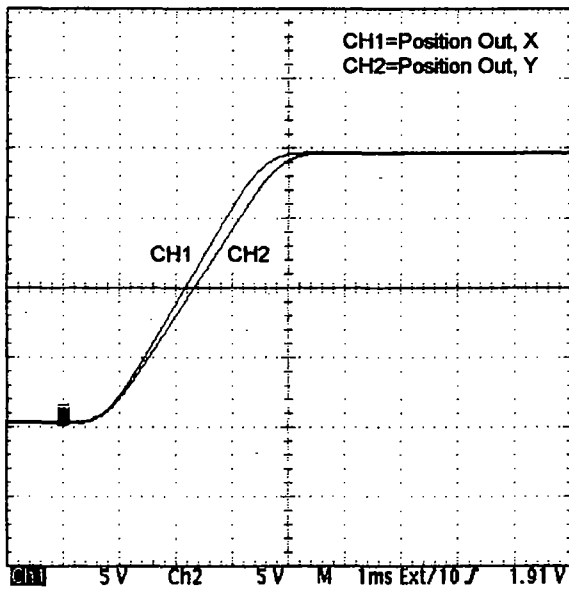

Figure 34.

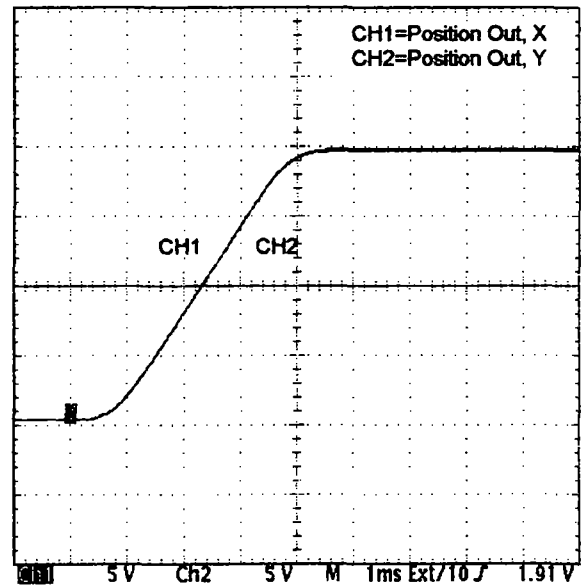

Figure 35.

6.2. 6740-XX Notch Filter Module

6.2.1 Background Theory

All mechanical systems are subject to vibrations via external excitation forces. The degrees of freedom of a vibrating mechanical system are defined by the number of independent coordinates required to identify its displacement during vibration. If we have a Cartesian coordinate system with x, y, and z axis, then for a freely vibrating body, we can have six degrees of freedom. This includes translational and rotational vibration in each of the three axis. Each of these possible vibrations is referred to as a *mode of vibration*. Each mode of vibration has a natural frequency associated with it that is independent of all the other modes.

For our discussion with respect to the scanner, we will concentrate on the rotational axial mode of vibration. The natural frequency F_r of this mode is a function of the mirror load inertia and rotor inertia as well as the torsional spring constant of the rotor shaft which couples the two inertias. The *undamped natural resonant frequency* of this mechanical system is described by the equation below:

$$\omega_R = k^{1/2} [(J_1 + J_2) / J_1 J_2]^{1/2}, \quad F_r = \omega_R / 2\pi$$

where k = rotor torsional spring constant

J_1 = mirror load inertia

J_2 = rotor inertia

Note that in a real mechanical scanner system damping due to bearing friction, air friction on the rotor and mirror load, etc. do indeed exist. However, CTI scanners exhibit very low bearing friction, and the above equation will approximate the resonant frequency quite closely. The damping constant inversely influences the natural resonant frequency slightly. In other words, as the damping constant increases, the natural resonant frequency decreases.

This torsional resonant frequency can exhibit a high Q , which is defined in one sense as the sharpness and amplitude of the resonant frequency peak. If this resonance occurs in a closed loop servo system where the gain vs frequency has fallen off enough that the (negative) position feedback phase shift approaches 180° , and the amplitude peaking at resonance is enough that the position feedback gain rises near unity, servo loop instability and oscillations will result. This is the reason for using a notch filter in the forward path of the servo loop, after the summing amplifier. The notch filter is tuned to remove the frequency component of the error drive signal sent to the scanner control coil which is at the same frequency as the scanner torsional resonance. This keeps the scanner from being excited at its resonant frequency. The rejection of this driving frequency aids the stability of the servo by not exciting this natural resonant mode, and allows the closed loop bandwidth of the system to be higher. Higher closed loop bandwidth allows decreased step response times.

However, this does not mean that the scanner torsional resonance disappears. Ideally, it is only that the servo amplifier no longer “kicks” the scanner at this frequency.

6.2.2 Notch Filter Tuning Procedure

The 6740-XX Notch Filter Module (NFM) is designed to be inserted into J5 of the 670 servo amp. The selection of the proper NFM is described below, along with tuning information.

Overview

This procedure indicates how to:

- 1) Determine the 1st torsional resonant frequency (**Fr**) of a *scanner and mirror load combination*
- 2) Select the proper 6740-xx Notch Filter Module (**NFM**)
- 3) Insert and Tune the NFM to the Fr

This procedure assumes the following:

- A properly heat-sinked, working 670 board is hooked up to a power supply with adequate current capability
- A working scanner *with mirror load* is in an X-Y mount or test clamp similar to what the end use would provide, and connected to the 670 board
- The proper test equipment for normal system tuning is also set up and ready
- The 670 schematic and outline drawings are in front of you.
- The 6740 Notch Filter Module schematic is in front of you

Equipment Needed:

- Oscilloscope (dual trace, minimum 60Mhz BW)
- Frequency counter

* 670 board GND connection points: **TP2, W7.2**

6.2.2.1 Determining Fr:

- a) Set signal generator to 1khz sine wave, lowest amplitude. Note that we are assuming that Fr will be above 1Khz. Connect a frequency counter to the output of the signal generator with a "T" connector.
- b) Without the NFM inserted into J5 (servo loop is broken), connect the signal generator to TP6. Ground can be obtained on TP2 or W7.2.
- c) Observe position (TP1) and current (TP3) with scope.
- d) Turn on power and signal generator.

- e) Adjust the signal generator for about 200mV peak on current. This is a ballpark figure. The main concern is that the current through the coil be large enough to view with good S/N ratio, but small enough to avoid excessive coil heating and mechanical vibration of the scanner while performing this test. Maintain the position signal near 0 volts by adjusting the DC offset control of the function generator accordingly.
- f) Slowly sweep frequency up while observing position and current on scope. Note the frequency where a peaking occurs in the position and/or current waveform. This is F_r . You can also hear the scanner become louder at F_r as well. *When F_r is identified, keep the signal generator at this frequency and shut it off promptly, as well as board power. Bearing wear will result if the scanner is held at the resonant frequency for too long.*

6.2.2.2. Selecting the proper 6740-xx NFM

The 6740-xx NFM's come in six different frequency ranges:

6740-06	12.5-20 Khz
6740-05	7-14 Khz
6740-04	5-10 Khz
6740-03	3.7-7.5 Khz
6740-02	2.2-4.5 Khz
6740-01	1.6-3.4 Khz

Select the proper NFM for the F_r measured in step (1.f) above. Choose one which the measured F_r is closest to the center of the range.

6.2.2.3. Inserting and tuning the 6740-xx NFM

Make sure that the 670 board is completely de-tuned. This section of the procedure will not work otherwise.

- a) Insert the NFM with its solder side facing the 670 heatsink bracket.
- b) Connect TP4 to ground via jumper clip. This open circuits the output amp so that it will not be driving the scanner during NFM adjustment
- c) Connect the signal generator to TP5. This is the summing amp input. Connect the scope probe to TP6. This is the NFM output.
- d) Turn on the signal generator and observe the NFM output on the scope. The signal generator should still be set at the resonant frequency F_r from the previous measurement. This is very important, since the NFM has a sharp attenuation characteristic. If the frequency that the NFM is being tuned to reject is not exactly at the F_r of the scanner and

load combination, ringing may still occur when tuning the scanner. This is especially true for high Q scanner torsional resonances. The viscous damping coefficient increases as the scanner RMS current (acceleration) increases, *shifting the resonant frequency downward slightly with higher tuning speeds*. This tends to de-stabilize the system when a fixed frequency, high Q notch filter is used. Lower Q notch filters can counteract this.

- e) Adjust the Frequency pot on the NFM until a minimum is obtained in the NFM output waveform.
- f) Now adjust the Depth pot on the NFM to further minimize the output waveform.
- g) Repeat steps (e) and (f) until the NFM output waveform at F_r is minimized as much as possible. At this point, you are done.

6.3. Schematics and Assembly Drawings

This section contains the following schematic and assembly drawings.

- | | |
|--|--------|
| 1.) 670 Schematic | D03310 |
| 2.) 670 Assembly Drawing, Top Side | D03311 |
| 3.) 670 Assembly Drawing, Bottom Side | D03312 |
| 4.) 670 Outline Drawing | D03457 |
| 5.) 6010-1 Drive Cable Assembly Drawing | D00898 |
| 6.) 6010-8 Drive Cable Assembly Drawing | D01978 |
| 7.) 6010-8L Drive Cable Assembly Drawing | D03187 |
| 8.) 6010-11 Drive Cable Assembly Drawing | D02430 |
| 9.) 6010-16 Drive Cable Assembly Drawing | D03188 |
| 10.) 6010-17 Drive Cable Assembly Drawing | D03190 |
| 11.) 6010-17L Drive Cable Assembly Drawing | D03189 |

ifications are the property of INC. and shall not be reproduced, or used for the manufacture, or the written permission of INC.

REVISION RECORD			
LTR	ECO NO:	APPROVED:	DATE:

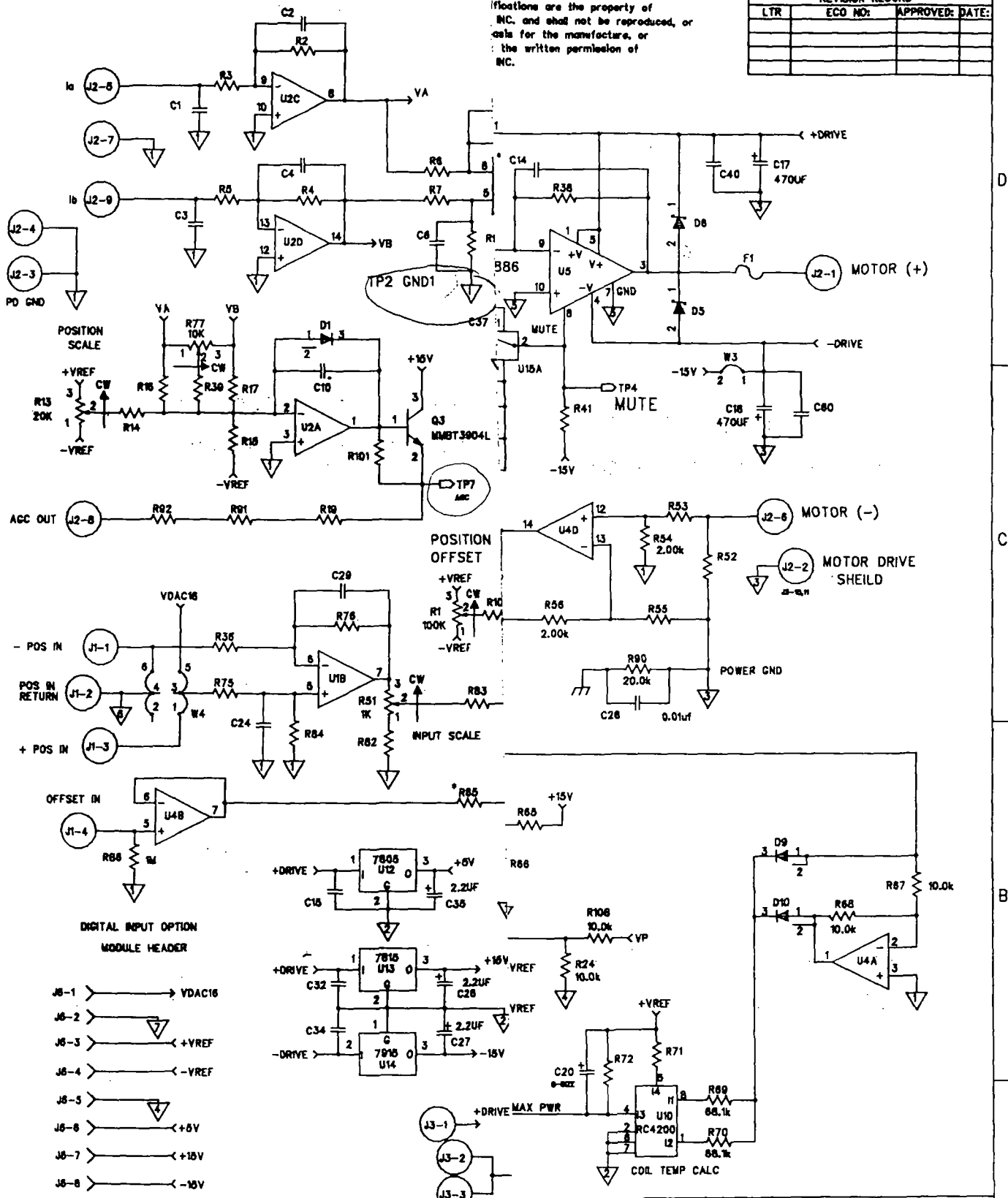

DIGITAL INPUT OPTION
MODULE HEADER

- J6-1 → VDAC16
- J6-2 →
- J6-3 → +VREF
- J6-4 → -VREF
- J6-5 →
- J6-6 → +6V
- J6-7 → +15V
- J6-8 → -15V

LC. PWR & BYPASS CAP CONNECTIONS

LC	+15V	CAP	-15V	CAP
U1-U4	4	C41-44	11	C61-64
U6,7	3	C48-48	12	C65-68
U8	18	C47		
U9	14	C48		
U10			3	C67
U11,16	4	C49,51	11	C68,70
U15	13	C50	4	C69

* THRU-HOLE COMPONENTS

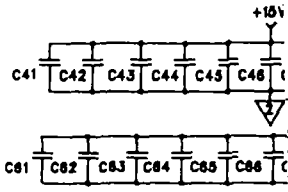

CAMBRIDGE TECHNOLOGY, INC.
100 SMITH PLACE
CAMBRIDGE, MA 02138

670 SMD SERVO AMP

KALOS	DATED: 8/30/97	SIZE: D	REV: B
NTROL:	DATED:	D03310	
DATED:		SCALE: NONE	SHEET: 1 OF 1

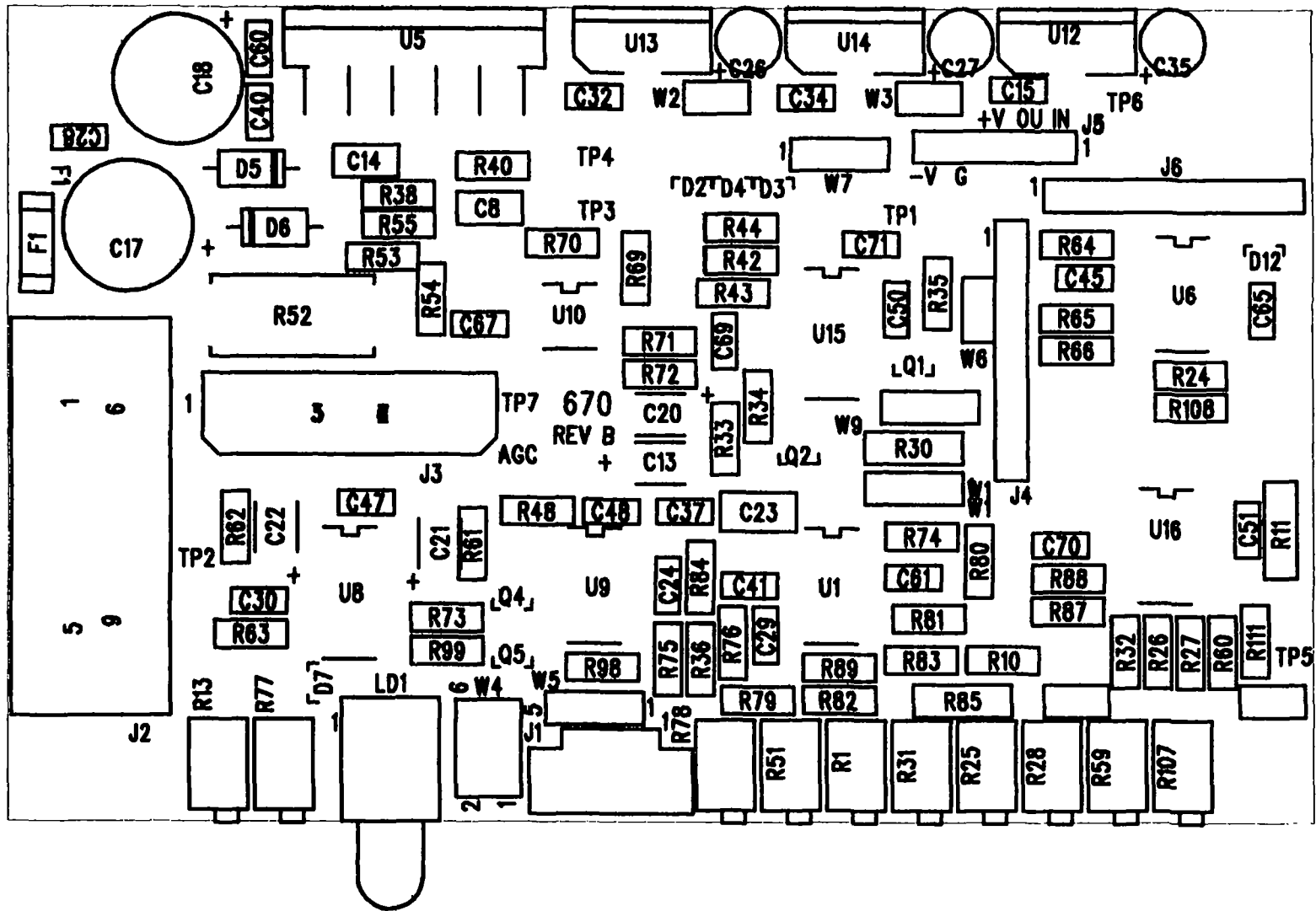

LAYER 1 SILKSCREEN D03320 REV B

AS VIEWED FROM TOPSIDE OF BOARD

UNLESS OTHERWISE SPECIFIED		DRN	CAMBRIDGE TECHNOLOGY, INC.	
TOLERANCES		DES	109 SMITH PLACE	
.XX = ±.010		CHK	CAMBRIDGE, MA. 02138 - USA	
.XXX = ±.005		ENG	670 SMD SERVO AMP.	
() INDICATES mm		APPR	ASSEMBLY DRAWING	
ANGLES ± 0°-30°		PROJECTION	TOPSIDE	
SURFACE ROUGHNESS			D03311	
BREAK ALL SHARP EDGES			REVISION	SCALE SHEET OF
MATERIAL	FINISH	B		
USED ON				

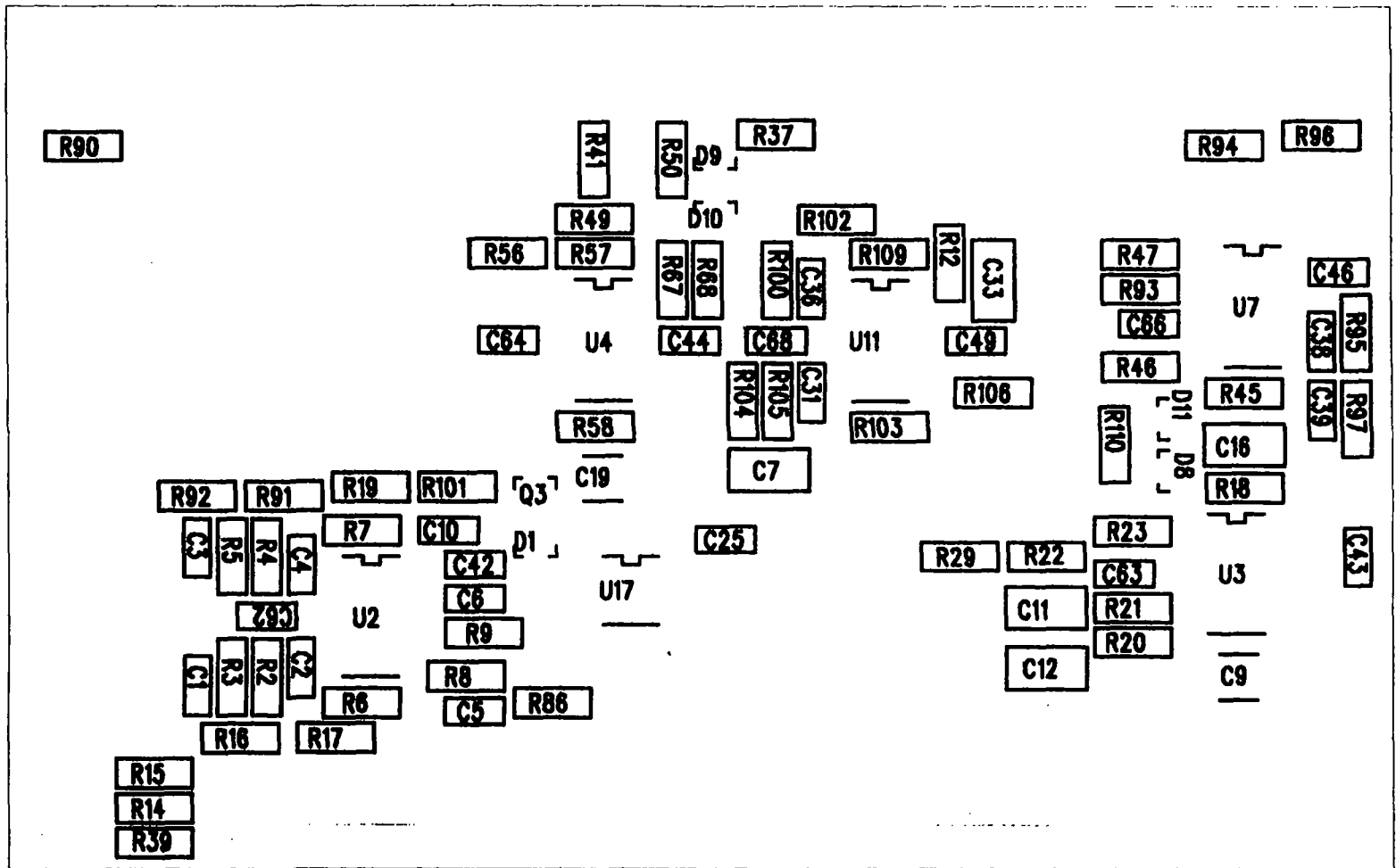

LAYER 4 SILKSCREEN D03321 REV B
 PARTS SEEN THROUGH TOP LAYER
 (X-RAY VIEW)

	UNLESS OTHERWISE SPECIFIED	DRN		CAMBRIDGE TECHNOLOGY, INC. 109 SMITH PLACE CAMBRIDGE, MA. 02138 - USA
	TOLERANCES	DES		
	.XX = ±.010	CHK		670 SMD SERVO AMP. ASSEMBLY DRAWING BOTTOM SIDE
	.XXX = ±.005	ENG		
	() INDICATES mm	APPR		D03312
	ANGLES ± 0°-30°	PROJECTION		
	SURFACE ROUGHNESS	REVISION		SCALE SHEET OF
	BREAK ALL SHARP EDGES	B		
	MATERIAL			
USED ON	FINISH			

These drawings and specifications are the property of CAMBRIDGE TECHNOLOGY and shall not be reproduced, in whole or in part, for the manufacture, or sale of equipment without the written permission of CAMBRIDGE TECHNOLOGY, INC.

REVISION			
REV	DESCRIPTION	CHK	DATE

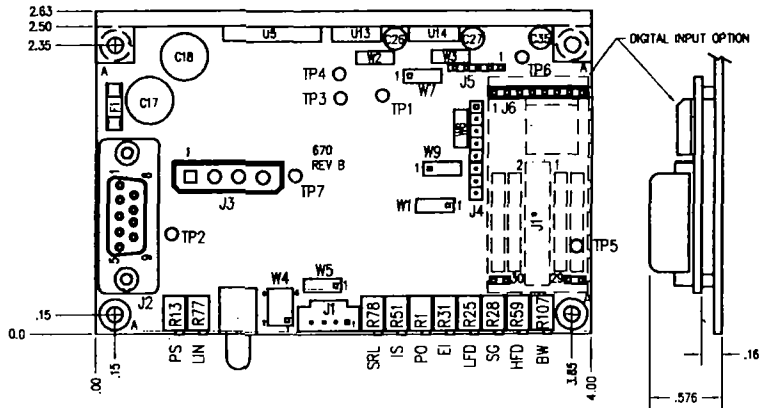

J1 (4 PIN) COMMAND INPUT CONNECTOR

PIN #	SIGNAL NAME
1	COMMAND (-)
2	COMMAND GND (SHIELD)
3	COMMAND (+)
4	OFFSET INPUT

J2 (9 PIN 'D') MOTOR CONNECTOR

PIN #	SIGNAL NAME
1	+ MOTOR
2	MOTOR SHIELD
3	AGC RET
4	DIODE COMMON
5	IA
6	- MOTOR
7	PD SHIELD
8	AGC CUT
9	IB

J3 (4 PIN) INPUT POWER CONNECTOR

PIN #	SIGNAL NAME
1	+ DRIVE VOLTAGE INPUT
2	+ DRIVE RETURN (GND)
3	- DRIVE RETURN (GND)
4	- DRIVE VOLTAGE INPUT

TRIM	FUNCTION
R1	POS. OFFSET (PO)
R13	POS. DET. SCALE FACTOR (PS)
R25	LOW FREQ. DAMPING (LFD)
R28	SERVO GAIN (SG)
R31	ERROR INTEGRATOR GAIN (EI)
R51	INPUT SCALE ADJUST (IS)
R59	HI FREQ DAMPING (HFD)
R77	POS. DET. LINEARITY ADJUST (LIN)
R78	SLEW RATE LIMITER (SRL)
R107	HF DAMPING BANDWIDTH ADJ. (BW)

J4 (8 PIN) OBSERVATION/CONTROL PORT

PIN #	SIGNAL NAME
1	VELOCITY OUT
2	POSITION OUT
3	GND #2
4	ERROR OUT
5	GND #4
6	90% MAX PWM FLAG OUTPUT
7	FAULT FLAG OUTPUT
8	REMOTE SHUTDOWN INPUT

J5 (5 PIN) NOTCH FILTER HEADER

PIN #	SIGNAL NAME
1	NOTCH FILTER INPUT
2	NOTCH FILTER OUTPUT
3	+ 15V
4	GND #1
5	- 15V

J6 (8 PIN) DIGITAL INPUT OPTION HEADER

PIN #	SIGNAL NAME
1	VDAC16
2	GND #7
3	+ VREF
4	- VREF
5	GND #4
6	+ 5V
7	+ 15V
8	- 15V

TEST POINTS	FUNCTION
TP1	POSITION SIGNAL, VP
TP2	GND #1
TP3	CURRENT MONITOR
TP4	MUTE PIN
TP5	SUMMING AMP INPUT
TP6	NOTCH FILTER OUTPUT
TP7	AGC OUT

J1* (30 PIN) DIGITAL PARALLEL INTERFACE

PIN #	LABEL	NOTES
1	DB6	
2	DB14	
3	CLR	
4	DB15	MS Bit
5	LDAC	DAC latch
6	DB12	
7	CS	
8	DB13	
9	GND	
10	DB10	
11	GND	
12	DB11	
13	R/W	
14	DB8	
15	GND	
16	DB9	
17	DB5	
18	DB0	LS Bit
19	GND	
20	DB7	
21	GND	
22	DB2	
23	GND	
24	DB1	
25	GND	
26	DB3	
27	GND	
28	DB4	
29	GND	
30	GND	

HOLE	QTY	SIZE
A	6	Ø.125 THRU
C	2	Ø.145 THRU
D	3	Ø.125 THRU, Ø.250 C/SINK FAR SIDE

UNLESS OTHERWISE SPECIFIED TOLERANCES .XX = ±0.010 .XXX = ±0.005 () INDICATES mm ANGLES ± 0°-30° SURFACE FINISHES SEE ALL DIM CODES	DRN PTH	1/7/88	CAMBRIDGE TECHNOLOGY, INC. 100 SMITH PLACE CAMBRIDGE, MA 02138 - USA 670 SMD SERVO AMP. OUTLINE D03457 SCALE 2x SHEET 1 of 1
	DES		
	CHK		
	ENG		
	APPR		
MATERIAL		PROJECTION E	
REVISION	A		
USED ON	FW5H		

These drawings and specifications are the property of CAMBRIDGE TECHNOLOGY and shall not be reproduced, or copied, or used as the basis for the manufacture, or sale of apparatus without the written permission of CAMBRIDGE TECHNOLOGY, INC.

REVISION				
ECO	REV	DESCRIPTION	APPR	DATE
368	A	ASSY VIEW ADDED	PTH	4/91
640	B	NOTES & CBL END PREP VIEW ADDED	PTH	8/94
-	C	LENGTH REDEFINED	PTH	8/96
1069	D	MFL HOOD MFG # CHG'D, STNDOFF REMVD	PTH	7/97

MALE AMLAN CDS 9L (P0070-0090)
W/C880002181 HOOD (P0070-0185)

8724 CABLE P0400-0001

FEMALE AMLAN CDF 9L (P0070-0082)
W/C880002181 HOOD (P0070-0185)

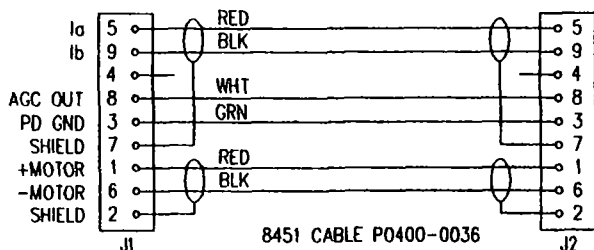

8451 CABLE P0400-0036

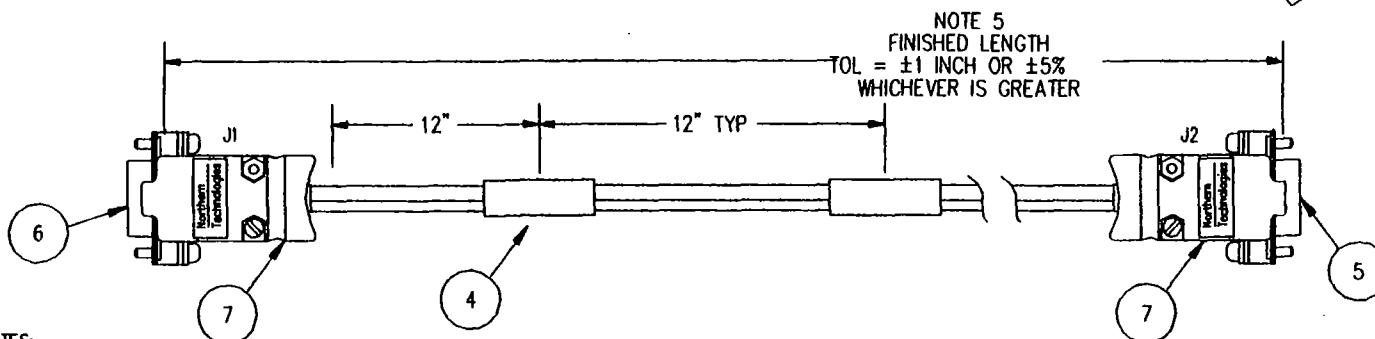
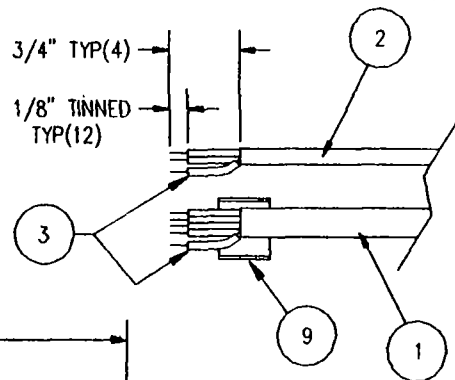

NOTE 5
FINISHED LENGTH
TOL = ±1 INCH OR ±5%
WHICHEVER IS GREATER

NOTES:

1. 4 COND CABLE IS BELDEN TYPE 8724(P0400-0001)
2. 2 COND CABLE IS BELDEN TYPE 8451(P0400-0036)
3. 1/16 HEATSHRINK TUBING (P0430-0018) TO BE USED ON SHIELD DRAIN WIRES.
4. +MOTOR IS DEFINED AS CAUSING A CW ROTATION OF THE OUTPUT SHAFT WHEN +MOTOR IS DRIVEN POSITIVE WITH RESPECT TO -MOTOR
5. "FINISHED LENGTH" DEFINED BY -XXX.
EXAMPLE : D00898-012 FINISHED LENGTH = 12"
6. MEDIAN CUT LENGTH (ON BOM) = FINISHED LENGTH.

UNLESS OTHERWISE SPECIFIED	DRN	10/3/88	B.A.	CAMBRIDGE TECHNOLOGY, INC. 23 ELM ST. WATERTOWN, MA. 02172 - USA
TOLERANCES	DES			
.XX±.010	CHK			6010-1-XXX SCANNER DRIVE CABLE
.XXX±.005	ENG			
() INDICATES mm	APPR			
ANGLES± 0'-30'	PROJECTION			D00898
MATERIAL	REVISION	D		
FINISH	SCALE	NONE	SHEET 1 OF 1	
USED ON				

These drawings and specifications are the property of CAMBRIDGE TECHNOLOGY and shall not be reproduced, or copied, or used as the basis for the manufacture, or sale of apparatus without the written permission of CAMBRIDGE TECHNOLOGY, INC.

REVISION				
ECO	REV	DESCRIPTION	APPR	DATE
516	B	P2 CONNECTOR CHANGED	PTH	2/93
	C	POLARIZATION NOTE FOR P2 REMOVED	PTH	5/93
642	D	STRIP & TIN NOTE ADDED	PTH	8/94
657	E	ITEM BUBBLES CORRECTED P0430-13 WAS P0430-0014	PTH	9/94
667	F	-13 FM -14 ABOVE RETURNED TO ORIG	PTH	11/94
-	G	DWG & TITLE UPDATED, LENGTH UPDATED	PTH	7/96
1079	G1	FINISHED LENGTH NOTES CLARIFIED	PTH	8/97

AMLAN CDS 9L (P0070-0090)
WITH C88000218 HOOD (P0070-0185)

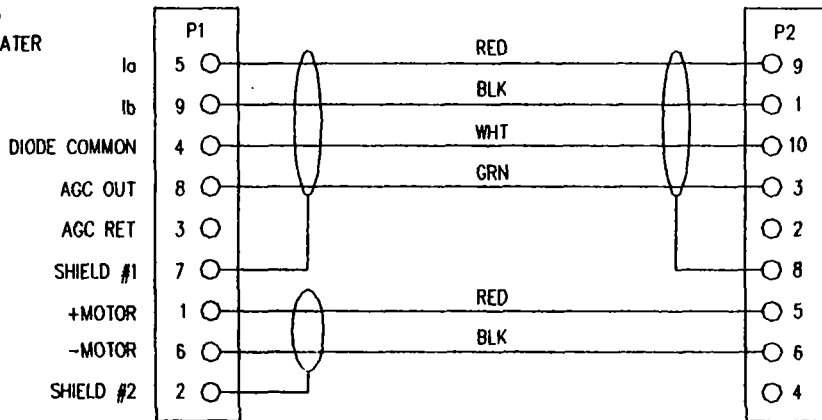

10 PIN AMP #102387-1 (P0070-0173)

(6) PLC'S WIRES ONLY
NOT ON SHIELDS.



FACE VIEW OF PLUG

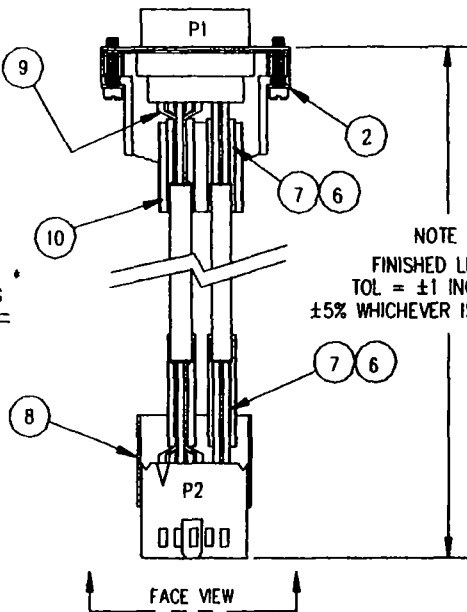

NOTE 7
FINISHED LENGTH
TOL = ±1 INCH OR
±5% WHICHEVER IS GREATER

NOTES:

- 4 CONDUCTOR WIRE - CTI #P0400-0065 (NEEWC#N11-40T-402)
- 2 CONDUCTOR WIRE - CTI #P0400-0066 (NEEWC#N11-40T-403)
- STRIP CABLE INSULATION BACK 3/4", STRIP & TIN WIRE INSULATION BACK 1/8" BOTH ENDS.
- USE HEATSHRINK TUBING #P0430-0014 OVERALL EVERY 12" CAPTURE FIRST PIECE UNDER HOOD (P0070-0091)
- USE COPPER FOIL - CTI #P0700-0047 ON BOTH ENDS OF EACH CABLE. FOIL MUST CONDUCT TO ITS CABLE'S DRAIN WIRE, AND MUST BE ISOLATED FROM EACH OTHER WITH HEATSHRINK #P0430-0015
- +MOTOR IS DEFINED AS CAUSING A CW ROTATION OF THE OUTPUT SHAFT WHEN +MOTOR IS DRIVEN POSITIVE WITH RESPECT TO -MOTOR
- MEDIAN CUT LENGTH (ON BOW) = FINISHED LENGTH.
- "FINISHED LENGTH" DEFINED BY -XXX.
EXAMPLE 6010-8-012 FINISHED LENGTH = 12"

	UNLESS OTHERWISE SPECIFIED TOLERANCES +0,-1 INCH	DRN PTH 10/92	CAMBRIDGE TECHNOLOGY, INC. 109 SMITH PLACE CAMBRIDGE, MA. 02138 - USA
	() INDICATES mm ANGLES ± 0'-30'	DES MDT 10/92	
	MATERIAL N/A	CHK	6010-8 68XX DRIVE CABLE
	FINISH N/A	ENG APPR	
USED ON		PROJECTION REVISION G	D01978
			SCALE NONE SHEET 1 OF 1

(6)PLC'S WIRES ONLY
NOT ON SHIELDS

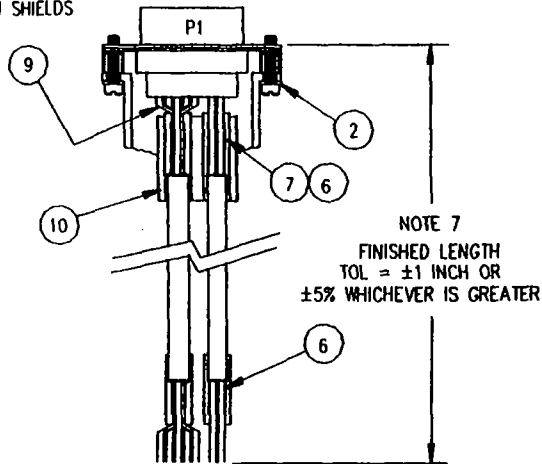

NOTES:

1. 4 CONDUCTOR WIRE - CTI #P0400-0065 (NEEWC/M11-40T-402)
2. 2 CONDUCTOR WIRE - CTI #P0400-0066 (NEEWC/M11-40T-403)
3. STRIP CABLE INSULATION BACK 3/4", STRIP & TIN WIRE INSULATION BACK 1/8" BOTH ENDS.
4. USE HEATSHRINK TUBING #P0430-0014 OVERALL EVERY 12" CAPTURE FIRST PIECE UNDER HOOD (P0070-0091)
5. USE COPPER FOIL - CTI #P0700-0047 ON 9 PIN 'D' END OF EACH CABLE. FOIL MUST CONDUCT TO ITS CABLE'S DRAWN WIRE, AND MUST BE ISOLATED FROM EACH OTHER WITH HEATSHRINK #P0430-0015
6. +MOTOR IS DEFINED AS CAUSING A CW ROTATION OF THE OUTPUT SHAFT WHEN +MOTOR IS DRIVEN POSITIVE WITH RESPECT TO -MOTOR
7. "FINISHED LENGTH" DEFINED BY -XXX.
EXAMPLE : 6010-BL-012 FINISHED LENGTH = 12"
8. MEDIAN CUT LENGTH (ON BOM) = FINISHED LENGTH.
9. 1/16" HEATSHRINK TUBING (P0430-0018) TO BE USED ON SHIELD DRAW WIRES ON NON-P1 END.

These drawings and specifications are the property of CAMBRIDGE TECHNOLOGY and shall not be reproduced, or copied, or used as the basis for the manufacture, or sale of apparatus without the written permission of CAMBRIDGE TECHNOLOGY, INC.

REVISION				
ECO	REV	DESCRIPTION	APPR	DATE
978A	B	NOTE B ADDED	PTH	3/97
1069	C	MTL HOOD MFG # CHG'D	PTH	7/97

AMLAN CDS 9L (P0070-0090)
WITH C880002181 HOOD (P0070-0185)

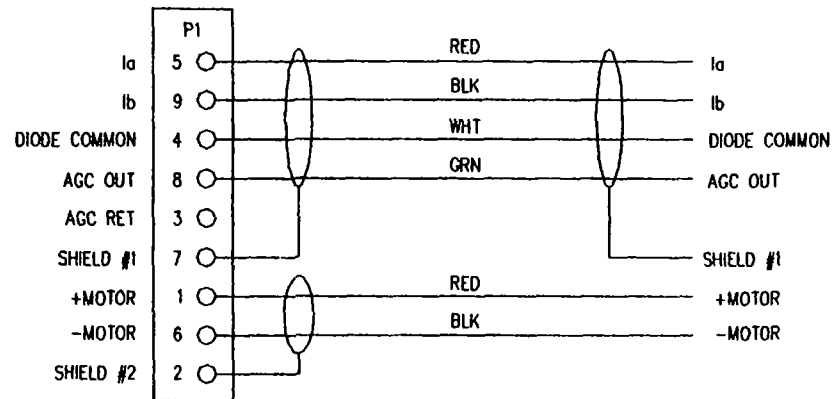

	UNLESS OTHERWISE SPECIFIED	DRN 03/04/97	PTH	CAMBRIDGE TECHNOLOGY, INC. 25 ELM ST. WATERTOWN, MA. 02172 - USA	
	TOLERANCES +0,-1 INCH	DES			
	() INDICATES mm ANGLES ± 0'-30'	CHK			
	MATERIAL	ENG			
	N/A	APPR		6010-8L-XXX 68XX DRIVE CABLE	
	FINISH	PROJECTION			
	N/A	REVISION		D03187	
USED ON		C		SCALE NONE	SHEET 1 OF 1

These drawings and specifications are the property of CAMBRIDGE TECHNOLOGY and shall not be reproduced, or copied, or used as the basis for the manufacture, or sale of apparatus without the written permission of CAMBRIDGE TECHNOLOGY, INC.

REVISION				
ECO	REV	DESCRIPTION	APPR	DATE
632	B	SEE ECO	PTH	6/94
-	C	LENGTH REDEFINED	PTH	8/96
1069	D	MTL HOOD MFG # CHG'D STNDOFF'S REMY'D	PTH	7/97

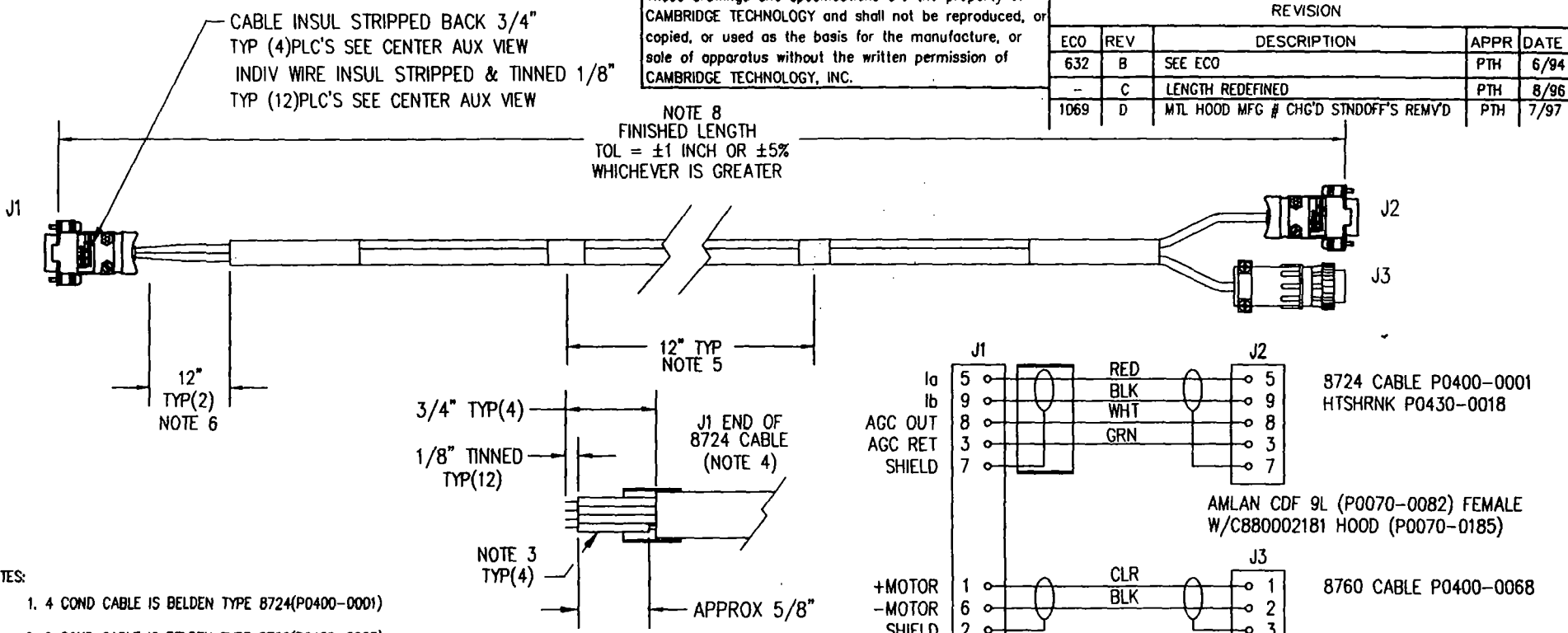

- NOTES:
- 4 COND CABLE IS BELDEN TYPE 8724(P0400-0001)
 - 2 COND CABLE IS BELDEN TYPE 8760(P0400-0068)
 - 1/16 HEATSHRINK TUBING (P0430-0018) TO BE USED ON SHIELD DRAIN WIRES OF 8724 & 8760 CABLES.
 - 3/16 HEATSHRINK TUBING (P0430-0023) TO BE USED ON 8724 CABLE AT J1 END TO COVER EXPOSED FOIL END AS SHOWN.
 - 3/8x1/2 BLK HEATSHRINK TUBING (P0430-0017) TO BE USED OVERALL EVERY 12 INCHES.
 - 3/8x2.5 HEATSHRINK TUBING (P0430-0011) TO BE PLACED 12 INCHES FROM EACH END OF THE CABLES AS SHOWN.
 - +MOTOR IS DEFINED AS CAUSING A CW ROTATION OF THE OUTPUT SHAFT WHEN +MOTOR IS DRIVEN POSITIVE WITH RESPECT TO -MOTOR
 - "FINISHED LENGTH" DEFINED BY -XXX.
EXAMPLE : 6010-11-012 FINISHED LENGTH = 12"
 - MEDIAN CUT LENGTH (ON BOM) = FINISHED LENGTH.

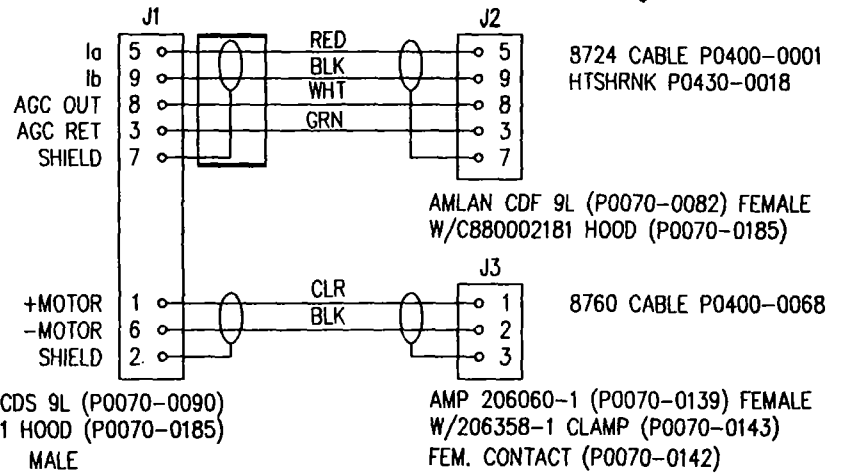

	UNLESS OTHERWISE SPECIFIED TOLERANCES .XX±.010 .XXX±.005 () INDICATES mm ANGLES± 0°-30'	DRN 6/2/84	PTH	CAMBRIDGE TECHNOLOGY, INC. 23 ELM ST. WATERTOWN, MA. 02172 - USA
	MATERIAL	PROJECTION 		D02430
	FINISH	REVISION D		
USED ON				

These drawings and specifications are the property of CAMBRIDGE TECHNOLOGY and shall not be reproduced, or copied, or used as the basis for the manufacture, or sale of apparatus without the written permission of CAMBRIDGE TECHNOLOGY, INC.

REVISION				
ECO	REV	DESCRIPTION	APPR	DATE
1089	B	MTL HOOD MFG / CHG'D. SINDOFFS REMV'D	PTH	7/97

MALE AMLAN CDS 9L (P0070-0090)
W/C880002181 HOOD (P0070-0185)

8724 CABLE P0400-0001

FEMALE AMLAN CDF 9L (P0070-0082)
W/C880002181 HOOD (P0070-0185)

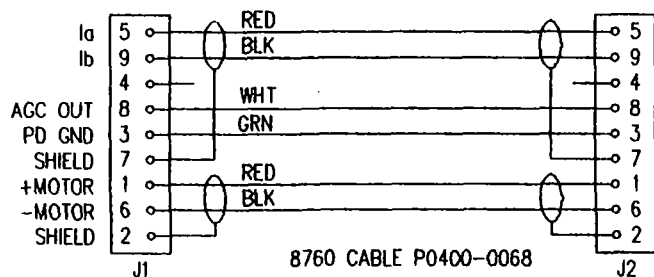

8760 CABLE P0400-0068

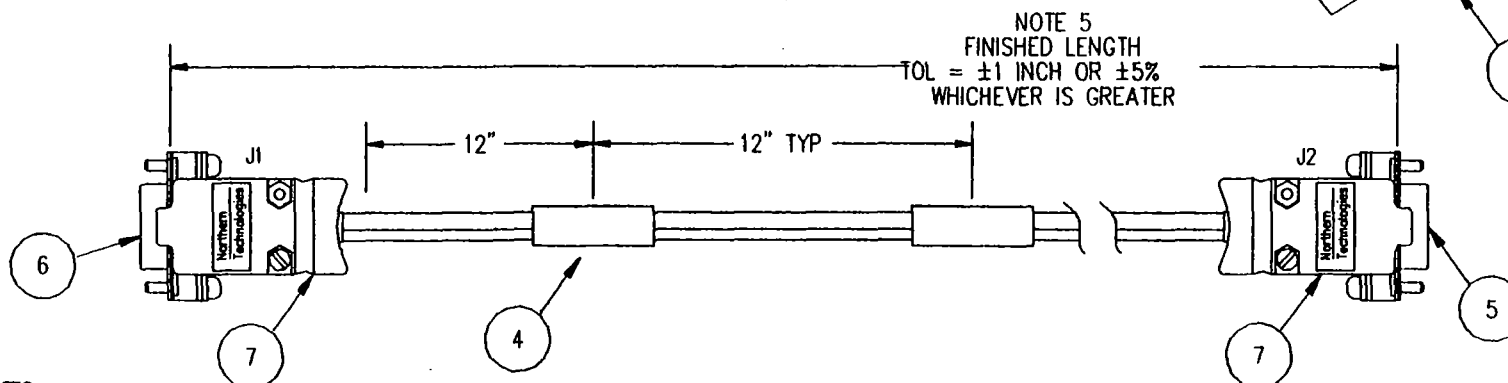
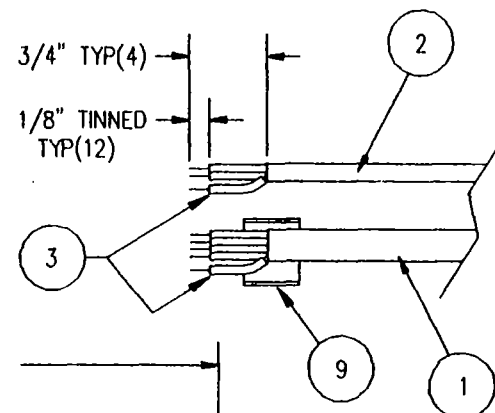

NOTE 5
FINISHED LENGTH
TOL = ±1 INCH OR ±5%
WHICHEVER IS GREATER

NOTES:

- 4 COND CABLE IS BELDEN TYPE 8724(P0400-0001)
- 2 COND CABLE IS BELDEN TYPE 8760(P0400-0068)
- 1/16 HEATSHRINK TUBING (P0430-0018) TO BE USED ON SHIELD DRAIN WIRES.
- +MOTOR IS DEFINED AS CAUSING A CW ROTATION OF THE OUTPUT SHAFT WHEN +MOTOR IS DRIVEN POSITIVE WITH RESPECT TO -MOTOR
- "FINISHED LENGTH" DEFINED BY -XXX.
EXAMPLE : 6010-16-012 FINISHED LENGTH = 12"
- MEDIAN CUT LENGTH (ON BOM) = FINISHED LENGTH.

	UNLESS OTHERWISE SPECIFIED TOLERANCES .XX±.010 .XXX±.005 () INDICATES mm ANGLES± 0°-30'	DRN 10/5/88 B.A.	CAMBRIDGE TECHNOLOGY, INC. 23 ELM ST. WATERTOWN, MA. 02172 - USA
		DES	
		CHK	
		ENG	6010-16-XXX SCANNER DRIVE CABLE
	MATERIAL	APPR	
		PROJECTION	
		REVISION	D03188
	FINISH	B	
USED ON			SCALE : NONE SHEET 1 OF 1

(6) PLC'S WIRES ONLY
NOT ON SHIELDS

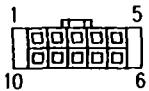
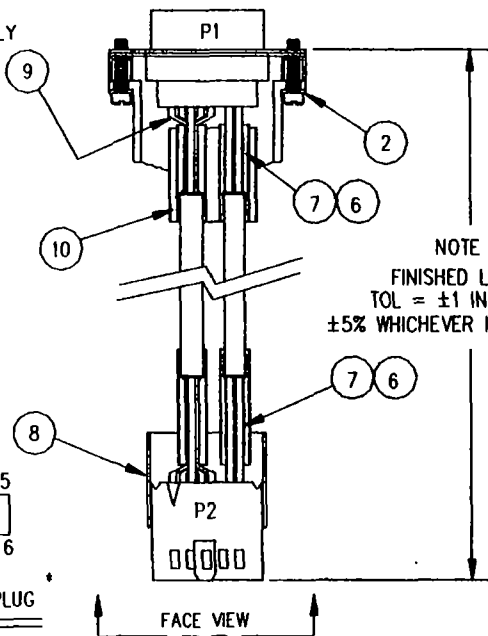

FACE VIEW OF PLUG

FACE VIEW

NOTES:

1. 4 CONDUCTOR WIRE - CTI #P0400-0065 (NEEWC#N11-40T-402)
2. 2 CONDUCTOR WIRE - CTI #P0400-0068 (BELDEN 8760)
3. STRIP CABLE INSULATION BACK 3/4", STRIP & TIN WIRE INSULATION BACK 1/8" BOTH ENDS.
4. USE HEATSHRINK TUBING #P0430-0017 OVERALL EVERY 12" CAPTURE FIRST PIECE UNDER HOOD (P0070-0091)
5. USE COPPER FOIL - CTI #P0700-0047 ON BOTH ENDS OF EACH CABLE. FOIL MUST CONDUCT TO ITS CABLE'S DRAIN WIRE, AND MUST BE ISOLATED FROM EACH OTHER WITH HEATSHRINK #P0430-0015
6. +MOTOR IS DEFINED AS CAUSING A CW ROTATION OF THE OUTPUT SHAFT WHEN +MOTOR IS DRIVEN POSITIVE WITH RESPECT TO -MOTOR
7. "FINISHED LENGTH" DEFINED BY -XXX.
EXAMPLE : 6010-17-012 FINISHED LENGTH = 12"
8. MEDIAN CUT LENGTH (ON BOW) = FINISHED LENGTH.

These drawings and specifications are the property of CAMBRIDGE TECHNOLOGY and shall not be reproduced, or copied, or used as the basis for the manufacture, or sale of apparatus without the written permission of CAMBRIDGE TECHNOLOGY, INC.

REVISION

ECO	REV	DESCRIPTION	APPR	DATE
1069	B	MIL HOOD MFG # CHG'D	PTH	7/97
1188	C	NOTE 4 P0430-0017 WAS P0430-0014	PTH	2/98

AMLAN CDS 9L (P0070-0090)
WITH C880002181 HOOD (P0070-0185)

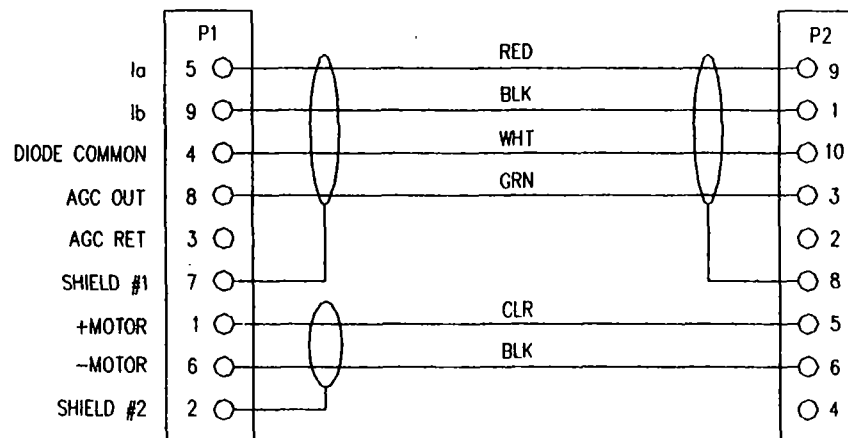

10 PIN AMP #102387-1 (P0070-0173)

	UNLESS OTHERWISE SPECIFIED TOLERANCES +0,-1 INCH	DRN 02/2797	PTH	CAMBRIDGE TECHNOLOGY, INC. 109 SMITH PLACE CAMBRIDGE, MA. 02138 - USA
	() INDICATES mm ANGLES ± 0°-30'	DES		
	MATERIAL N/A	CHK		6010-17-XXX 68XX DRIVE CABLE
	FINISH N/A	ENG		
USED ON		APPR	PROJECTION	D03190
		REVISION C		
				SCALE NONE
				SHEET 1 OF 1

(6) PLC'S WIRES ONLY
NOT ON SHIELDS

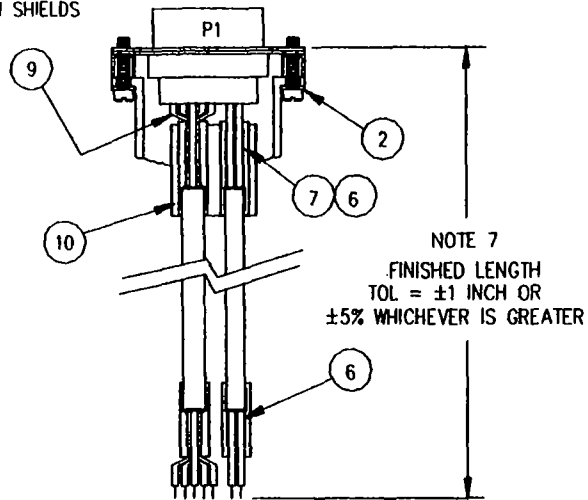

NOTES:

1. 4 CONDUCTOR WIRE - CTI #P0400-0055 (NEEWC#N11-40T-402)
2. 2 CONDUCTOR WIRE - CTI #P0400-0068 (BELDEN 8760)
3. STRIP CABLE INSULATION BACK 3/4", STRIP & TIN WIRE INSULATION BACK 1/8" BOTH ENDS.
4. USE HEATSHRINK TUBING #P0430-0017 OVERALL EVERY 12" CAPTURE FIRST PIECE UNDER HOOD (P0070-0091)
5. USE COPPER FOIL - CTI #P0700-0047 ON 9 PIN 'D' END OF EACH CABLE. FOIL MUST CONDUCT TO ITS CABLE'S DRAIN WIRE, AND MUST BE ISOLATED FROM EACH OTHER WITH HEATSHRINK #P0430-0015
6. +MOTOR IS DEFINED AS CAUSING A CW ROTATION OF THE OUTPUT SHAFT WHEN +MOTOR IS DRIVEN POSITIVE WITH RESPECT TO -MOTOR
7. "FINISHED LENGTH" DEFINED BY -XXX
EXAMPLE : 6010-17L-012 FINISHED LENGTH = 12"
8. MEDIAN CUT LENGTH (ON BOM) = FINISHED LENGTH.
9. 1/16" HEATSHRINK TUBING (P0430-0018) TO BE USED ON SHIELD DRAIN WIRE ON NON-P1 END

These drawings and specifications are the property of CAMBRIDGE TECHNOLOGY and shall not be reproduced, or copied, or used as the basis for the manufacture, or sale of apparatus without the written permission of CAMBRIDGE TECHNOLOGY, INC.

REVISION

ECO	REV	DESCRIPTION	APPR	DATE
978A	B	NOTE 8 ADDED	PTH	3/97
1069	C	MTL HOOD MFG # CHG'D	PTH	7/97
1188	D	NOTE 4 P0430-0017 WAS P0430-0014	PTH	2/98

AMLAN CDS 9L (P0070-0090)
WITH C880002181 HOOD (P0070-0185)

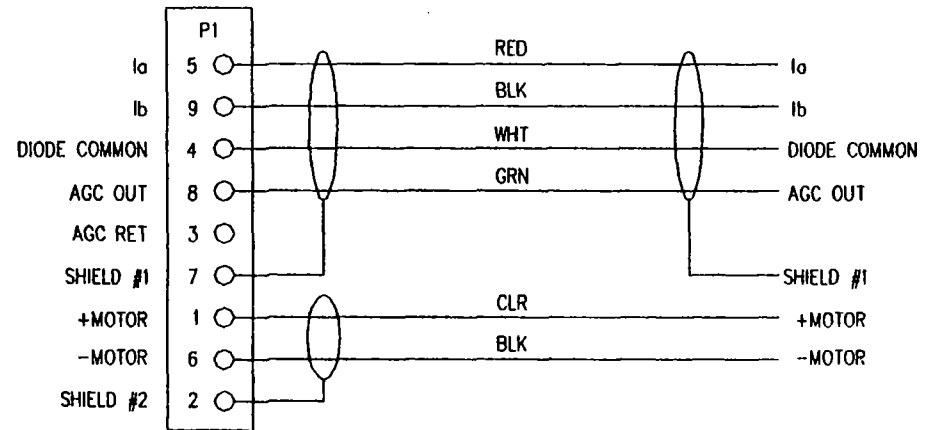

	UNLESS OTHERWISE SPECIFIED TOLERANCES +0,-1 INCH	DRN 03/04/97	PTH	CAMBRIDGE TECHNOLOGY, INC. 23 ELM ST. WATERTOWN, MA. 02172 - USA
	() INDICATES mm ANGLES ± 0°-30'	DES		
	MATERIAL	CHK		6010-17L-XXX 68XX DRIVE CABLE
	N/A	ENG		
	FINISH	APPR		D03189
	N/A	PROJECTION		
USED ON		REVISION	D	SCALE NONE
				SHEET 1 OF 1