

## LUCAS MARINE A127MT MARINISED ALTERNATOR

All machines in this range are of the machine sensed insulated return type. The end brackets are protected by a special treatment whilst the windings, rotor and rectifier feature additional protection.

The backplate (SRE bracket) retains the output, field and tachometer connections. The regulator is also mounted for easy access. Radio interference capacitors are connected across both the + Ve and - Ve terminals and the use of LM119/75 47020002 suppression unit will provide RI suppression beyond BS1597 levels.

A wide variety of pulleys and spacers is available to ensure accurate fit and alignment for most applications. A list of these is included.

The front bracket is available for LH and RH fixing with the exception of the Propshaft model (RH). All machines are clockwise rotation.

The range starts with a 12v 15A model designed with a low cut-in speed (L.C.I.S) for use as a sailing craft propshaft generator or with low speed engines.

The next machine in the range is the 12v 55A version designed to meet the higher output requirements of vessels with mid-sized engines.

At the top of the 12v range is the 70A machine with a higher output enabling good battery charging rates with capacity to spare for the ever increasing electrical loads found in today's vessels.

As well as the 12v units there is a 24v 40A model providing 24 volt power at low cost.

### DESPATCH REFERENCE AND DATA SUMMARY

#### 12V

s. No	Model	Hand	W/L Required	Cut-in Speed (rpm)	Output @ 2000 rpm	Max Output (13.5v)6000rpm
47020056	A127-55MT	LH	2.2W	1100	34A	55A
47020057	A127-55MT	RH	2.2W	1100	34A	55A
47020067	A127-70MT	RH	2.2W	1100	45A	70A
47020069	A127-70MT	LH	2.2W	1100	45A	70A
47020070	A127-15MT	RH	2.2W	800	13A	15A

#### 24V

47020060	A127-40MT	LH	4W	1800	12A	40A
47020061	A127-40MT	RH	4W	1800	12A	40A

All machines have a maximum speed of 15000 rpm. The A127-15A and A127-55A machines have an operating temperature range of -40°C to 100°C air inlet temperature. This is reduced to 80°C maximum for the A127-70A and A127-40A models.



# A127 INSTALLATION NOTES

## DESCRIPTION

---

The A127 Alternator is a marine finish, machine sensed insulated return machine. An additional terminal (W) is incorporated to provide an AC signal which may be used to drive a tachometer or speed sensing device.

The Alternator is a swung mounted two lug fitting suitable for RH or LH mounting.

The drive is via a pulley fitted to the 17mm keyless shaft.

## SELECTION OF PULLEY AND SPACER

---

To enable the alternator to be driven at it's optimum speed (see performance curve), a pulley should be selected from the chart.

The overhang required to bring the alternator pulley in line with the drive pulley (dimension 'A' Fig 1) may be obtained by the use of a suitable spacer fitted between the pulley and the fan support washer. The attached list details the spacers available.

N.B. A spacer of minimum size (as specified in the pulley section) must always be fitted.

## SEAWATER INGRESS

---

All A127-MT series marine alternators are designed to operate in a saline environment. Care should be taken to avoid direct watersplash and on exposed installations, A127 splash cover; despatch reference 54206418 can be fitted to provide additional protection.

In the event of excessive water ingress or complete submersion, the machine must be removed as soon as possible, all excess water removed and taken to the nearest agent for an immediate overcheck. Failure to observe these basic precautions may lead to the loss of a good machine or invalidate your warranty.

## SPLIT CHARGING

---

Split charging with the A127-MT series requires the installation of a suitable continuously rated relay. Blocking diodes cannot be successfully used with this machine sensed design.

For both 12v and 24v applications we recommend the 33RA'M' relay available under the following despatch references:

12v - 47121004

24v - 47121005

These units are "Marine Finish" and highly competitively priced.

## EXTERNAL REGULATORS

---

The use of "SMART" external voltage regulators which bypass the alternator's integral regulator is not recommended and will invalidate your warranty.

The standard regulator fitted is the result of extensive design and development, providing a balance between machine durability, output and battery life.

## A127MT ALTERNATOR TYPES

TABULATED OUTLINE DRAWING = 04720158 - ALL TYPES

DESPATCH NO:	VOLTS	AMPS	RH / LH FIXING	PULLEY	PULLEY DESPATCH NO:	PULLEY SPACER	PULLEY SPACER DESPATCH NO:	FAN SUPPORT WASHER	FAN SUPPORT DESPATCH NO:
47020054	12	55	LH	54206027	-	-	-	-	-
47020055	12	55	RH	54206027	-	-	-	-	-
47020056	12	55	LH	-	-	-	54206432	54206432	47020080
47020057	12	55	RH	-	-	-	54206432	54206432	47020080
47020058	12	55	LH	-	-	-	54206432	54206432	47020080
47020059	12	55	RH	-	-	-	54206432	54206432	47020080
47020060	24	40	LH	-	-	-	54206432	54206432	47020080
47020061	24	40	RH	-	-	-	54206432	54206432	47020080
47020062	12	55	LH	54205643	47020076	54205634	47020079	54206432	47020080
47020063	12	55	LH	54205643	47020076	54205634	47020079	54206432	47020080
47020065	12	55	RH	54205639	47020071	54205634	47020079	54206432	47020080
47020067	12	70	RH	-	-	-	54206432	54206432	47020080
47020068	12	70	RH	54205646	47020082	54205634	47020079	54206432	47020080
47020069	12	70	LH	-	-	-	54206432	54206432	47020080
47020070	12	15	RH	54205639	47020071	54205634	47020079	54206432	47020080
47020083	24	40	RH	54205646	47020082	54205630	47020077	54206432	47020080
47020084	12	70	RH	54205643	47020076	54205721	54206432	54206432	47020080
47020086	12	55	RH	54205641	47020073	54205634	47020079	-	-
47020088	12	70	RH	54205646	47020082	54205721	54206432	54206432	47020080
47020089	12	55	RH	54205640	47020072	54205634	47020079	54206432	47020080
47020090	24	30	RH	54205643	47020076	54205721	54206432	54206432	47020080

## NOTES :-

- 1 - UNITS ARE INSULATED RETURN , CLOCKWISE ROTATION , AND FITTED WITH SUPPRESSION CAPACITORS
- 2 - UNITS HAVE AC TACHO PHASE TAP [ 0.250" LUCAR & M5 DIA STUD TERMINAL ]
- 3 - UNITS HAVE MAINS TERMINALS [ POSITIVE M6 DIA / NEGATIVE M5 DIA ]  
ALSO FITTED WITH TWIN POSITIVE 0.375" LUCAR PLUG WITH 0.250" LUCAR WARNING LIGHT TERMINALS  
[ TWIN 0.375" TERMINALS ARE BOTH POSITIVE IN ORDER TO LOAD SHARE ]
- 4 - ALL UNITS HAVE 17 MM DIA SHAFT
- 5 - RH FIXING = ADJUSTING LUG IS ON RIGHT HAND SIDE OF UNIT WHEN VIEWED FROM REAR  
[ TERMINAL ] END OF ALTERNATOR

# PULLEYS AND SPACERS

## PULLEYS

Desp.No	Belt Size	Outside Dia. (mm)	Approx Effective Dia.(mm)	Minimum Spacer Size	Min. 'A' Dimension (Overhang)
47020071	3/8"(9.7mm)	63	60	5.5mm	35,0mm
47020072	3/8"(9.7mm)	68	65	5.5mm	35,0mm
47020073	3/8"(9.7mm)	73	70	5.5mm	35,0mm
47020076	3/8"(9.7mm)	83	80	5.5mm	35,0mm
47020074	1/2"(12.7mm)	73	70	7.5mm	37,0mm
47020075	1/2"(12.7mm)	78	75	7.5mm	37,0mm
47020082	1/2"(12.7mm)	83	80	7.5mm	37,0mm

## SPACERS

Desp. no	Spacer Size	'A' Dim (Overhang)
47020077	7.5mm	37,0mm
47020078	10.0mm	39,5mm
47020079	5.5mm	35,0mm
47020080	2.0mm*	

\* USE ONLY IN ADDITION TO LARGER SPACERS

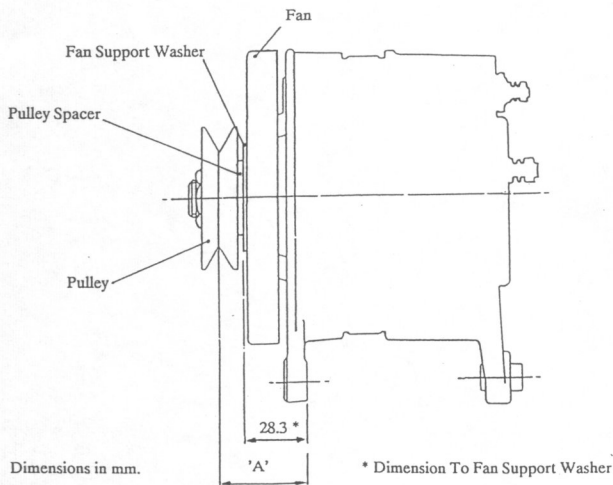

RADIO INTERFERENCE  
SUPPRESSION CAPACITOR  
LUCAS AG.3 x 0.8  
TO DIN 46244

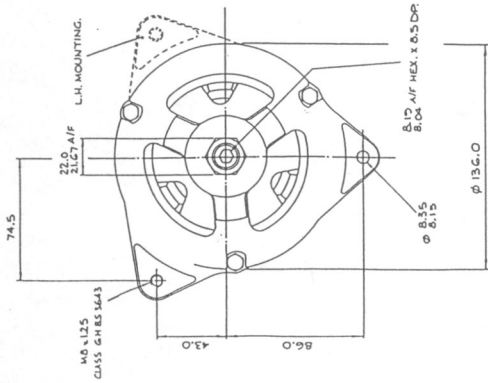
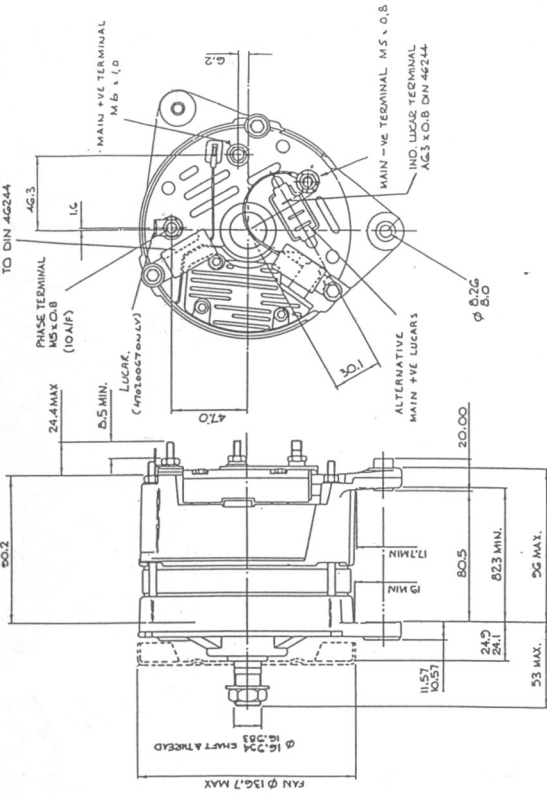

Dimensions in mm.

Lucas Marine

A127MT Marine Alternator

# A127-MT ALTERNATOR OUTPUT CURVE

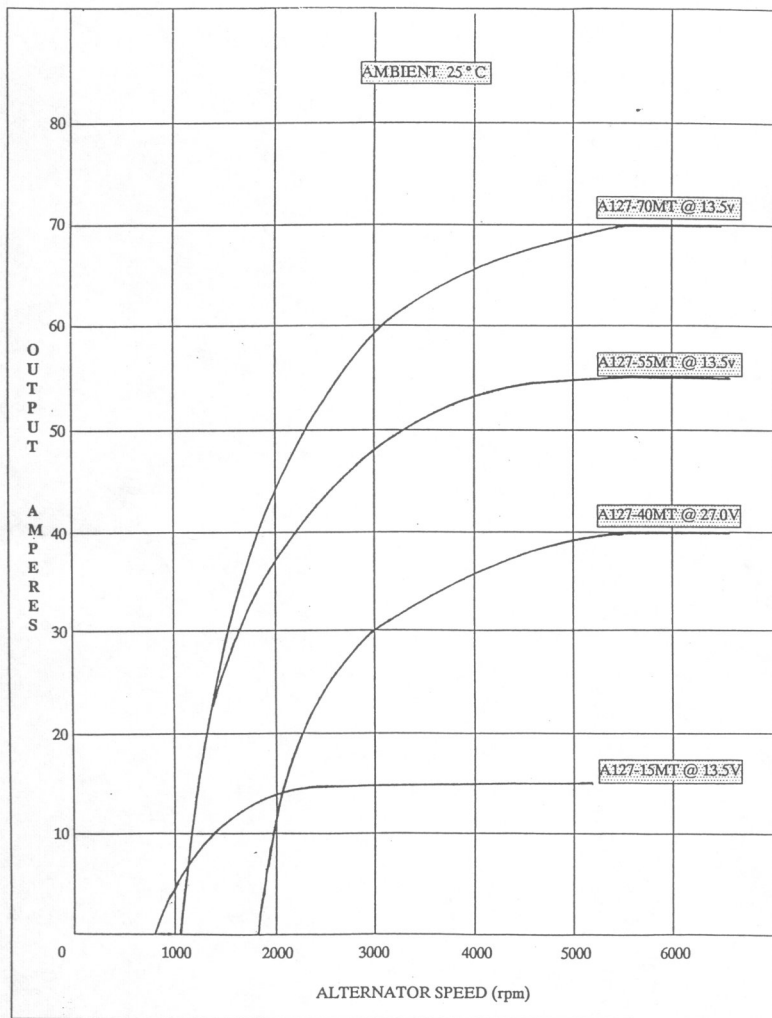

# A127MT CIRCUIT DIAGRAMS

## Single Battery Installation

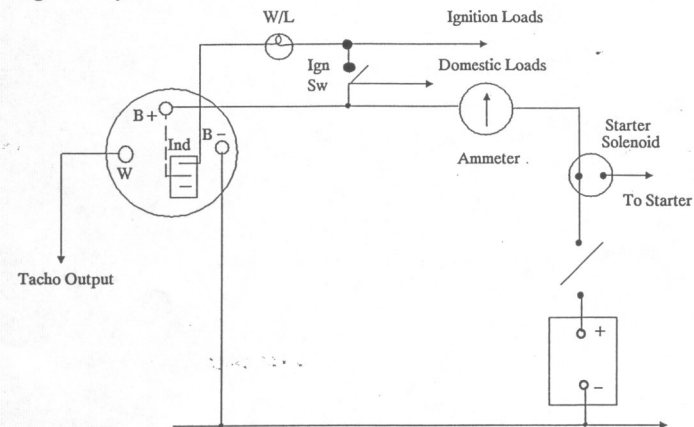

## Twin Battery Installation

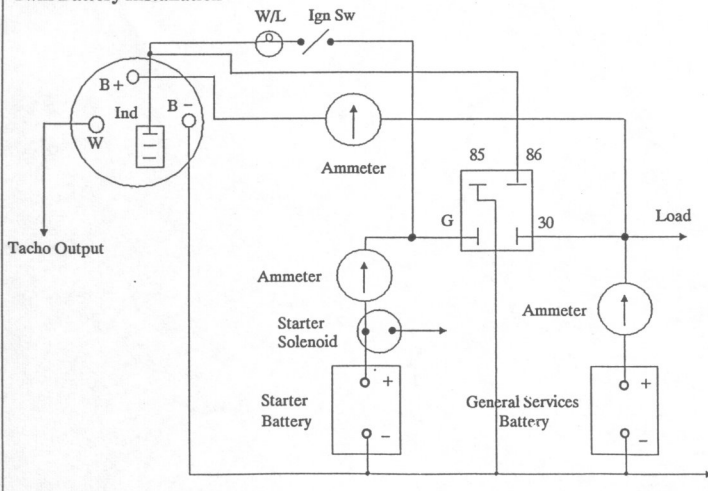





R.F.#	DESPATCH No.	SERVICE No.	DESCRIPTION	FIXING HANDED	ROTATION	ELECTRICAL DATA		PULLEY	PULLEY SPACER	FAN SUPPORT WASHER	O/HANG (MM)	
						VOLTS	NOM. O/P AT RPM.					
							TACHO TAKE OFF					
21	47020089	N/A	A 127-55MT ALTERNATOR I.R.	R.H.	CLOCK	12	55 AMP @ 6000	YES	54205640	54205634	54206432	36.6-35.0
20	47020090	N/A	A 127-30MT ALTERNATOR I.R.	RH	CLOCK	24	30 AMP @ 6000	YES	54205643	54205721	54206432	37.6-36.0
19	47020063	47920130A	A 127-55MT ALTERNATOR I.R.	L/H	CLOCK	12	55 AMP @ 6000	YES	54205643	54205634	54206432	36.6-35.0
18	47020062	47920130A	A 127-55MT ALTERNATOR I.R.	L/H	CLOCK	12	55 AMP @ 6000	YES	54205643	54205634	54206432	36.6-35.0
17	47020068	47920142A	A 127-70MT ALTERNATOR I.R.	R/H	CLOCK	12	70 AMP @ 6000	YES	54205646	54205634	54206432	36.6-35.0
16	47020058	47920130A	A 127-55MT ALTERNATOR I.R.	L/H	CLOCK	12	55 AMP @ 6000	YES	NOT SUPPLIED	NOT SUPPLIED	54206432	N/A
15	47020086	47920145A	A 127-55MT ALTERNATOR I.R.	R/H	CLOCK	12	55 AMP @ 6000	YES	54205641	54205634	NOT USED	32.5-31.1
14	47020084	47920164	A 127-70MT ALTERNATOR I.R.	R/H	CLOCK	12	70 AMP @ 6000	YES	54205643	54205721	54206432	37.6-36.0
13	47020055	47920131A	A 127-55MT ALTERNATOR I.R.	R/H	CLOCK	12	55 AMP @ 6000	YES	54206027	NOT USED	NOT USED	31.65-33.55
12	47020054	47920130A	A 127-55MT ALTERNATOR I.R.	L/H	CLOCK	12	55 AMP @ 6000	YES	54206027	NOT USED	NOT USED	31.65-33.55
11	47020065	47920131A	A 127-55MT ALTERNATOR I.R.	R/H	CLOCK	12	55 AMP @ 6000	YES	54205639	54205634	54206432	36.6-35.0
10	47020059	47920131A	A 127-55MT ALTERNATOR I.R.	R/H	CLOCK	12	55 AMP @ 6000	YES	NOT SUPPLIED	NOT SUPPLIED	54206432	N/A
9	47020083	47920135A	A 127-40MT ALTERNATOR I.R.	R/H	CLOCK	24	40 AMP @ 6000	YES	54205646	54205630	54206432	38.6-37.0
8	47020088	47920142A	A 127-70MT ALTERNATOR I.R.	R/H	CLOCK	12	70 AMP @ 6000	YES	54205646	54205721	54206432	37.6-36.0
7	47020070	47920144A	A 127-15MT ALTERNATOR I.R.	R/H	CLOCK	12	15 AMP @ 6000	YES	54205639	54205634	54206432	36.6-35.0
6	47020069	47920143A	A 127-70MT ALTERNATOR I.R.	L/H	CLOCK	12	70 AMP @ 6000	YES	NOT SUPPLIED	NOT SUPPLIED	54206432	N/A
5	47020067	47920142A	A 127-70MT ALTERNATOR I.R.	R/H	CLOCK	12	70 AMP @ 6000	YES	"	"	54206432	"
4	47020061	47920135A	A 127-40MT ALTERNATOR I.R.	R/H	CLOCK	24	40 AMP @ 6000	YES	"	"	54206432	"
3	47020060	47920134A	A 127-40MT ALTERNATOR I.R.	L/H	CLOCK	24	40 AMP @ 6000	YES	"	"	54206432	"
2	47020057	47920131A	A 127-55MT ALTERNATOR I.R.	R/H	CLOCK	12	55 AMP @ 6000	YES	"	"	54206432	"
1	47020056	47920130A	A 127-55MT ALTERNATOR I.R.	L/H	CLOCK	12	55 AMP @ 6000	YES	"	"	54206432	"

STANDARD ALTERNATORS