

JVC

SERVICE MANUAL

MODEL
QL-A2

QUARTZ AUTO-RETURN
TURNTABLE



No. 2444
JAN. 1978

Contents

	Page
1. Specifications	2
2. Service Precautions	3
3. Features	3
4. "How to Operate" (Names and Functions)	3
5. Operation of Automatic Mechanism	4
6. Block Diagrams	
6-(1) Servomotor Control System	5
6-(2) IC802 Integrated Circuits and Waveforms	5
7. Troubleshooting	
7-(1) Platter does not rotate	6
7-(2) Platter rotates at high speed	7
7-(3) Rotation is not locked to the crystal oscillator frequency	7
8. Cartridge Replacement	8
9. Adjustment Procedures	
Servomotor Control Section	
9-(1) Power Supply Voltage Check	8
9-(2) Lock Adjustment	8
Tonearm Section	
9-(3) Overhang Adjustment	9
9-(4) Tonearm Lifter Height Adjustment	9
9-(5) Auto-return (Lead-out) Adjustment	9
9-(6) Tracking Force Adjustment	10
9-(7) Anti-skating Adjustment	10
10. Lubrication	11
11. Exploded Views and Parts List	
11-(1) Cabinet and Mechanism Assembly	11
11-(2) Mechanism Base Assembly	13
11-(3) Knob Base Assembly	13
11-(4) Tonearm Assembly	14
11-(5) Parts List with Specified Numbers for Designated Areas	14
12. Connection Diagram of TXX-124	15
13. TXX-124 Schematic Diagram	16
14. TXX-124 Printed Circuit Board Ass'y and Parts List	17
15. Packing Materials and Part Numbers	21
16. Accessories List	21
17. QL-A2 Schematic Diagram	22

WARNING!

When replacing the parts marked with , be sure to use the designated parts to ensure safety.

CHECKING YOUR LINE VOLTAGE (For U.S. Military Market and Other Countries)

Before inserting the power plug, please check this setting to see that it corresponds with the line voltage in your area. If it doesn't, be sure to adjust the voltage selector switch to the proper setting before operating this equipment. The voltage selector switch is located either on the set's on the chassis. Simply insert a screw driver into the voltage selector switch and turn it in either direction while pressing slightly and in such a way that desired voltage marked on the switch is positioned underneath the arrow marked on the rear panel or the chassis. The voltage selector switch accommodates up to three turns in either direction.

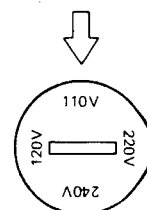

1. Specifications

Motor section

Motor : Coreless, DC type FG servomotor
 Drive system : Direct drive
 Speeds : 33-1/3 and 45 rpm
 Wow and flutter : Less than 0.025 % (WRMS)
 Rumble : More than 62 dB (IEC-B)
 More than 72 dB (DIN-B)
 Speed detection : Integrated frequency generator
 Starting torque : More than 650 g·cm
 Speed deviation : Within 0.004 %
 Load characteristics : 0 % (with 100 g total tracking force)
 Drift per hour : 0.0001 %/H
 Power characteristics : 0 % (± 10 % V)
 Temperature characteristics : 0.00005 %/°C
 Platter : 31.2 cm diameter

Tonearm section

Type : T.H. (Tracing-Hold system, static balance)
 Effective length : 220 mm
 Tracking error : +3°35' - 0°43'
 Overhang : 15 mm
 Tracking force range : 0 - 3 g (0.25 grams division, direct reading)
 Weight range (including headshell) : 14.5 - 21 g (Headshell 10 g)

Cartridge section (not provided on units for U.S.A., Canada and the U.K.)

Type : Moving Magnet (Cartridge body: MD-1025)
 Stylus : 0.5 mil. diamond (DT-Z1S)
 Optimum tracking force : 2 grams
 Output : 3 mV (1 kHz)
 Frequency response : 10 to 25 000 Hz
 Separation : More than 25 dB (1 kHz) (with test record TRS-1)
 Load resistance : 47 kilohms - 100 kilohms
 Compliance : 10 x 10⁻⁶ cm/dyne (Dynamic)
 30 x 10⁻⁶ cm/dyne (Static)

General

Dimensions : 14.7 (H) x 46.0 (W) x 36.5 (D) cm (with cover closed)
 (5-13/16" x 18-1/8" x 14-3/8")
 (Since the dimensions show only the design
 measurements, consideration is required when
 installing the unit in a limited space such as a rack.)
 Weight : 6.5 kg (14.3 lbs)
 (without corrugated cardboard case)

Power Specifications

Countries	Line Voltage & Frequency	Power Consumption
U.S.A. & CANADA	AC 120 V, 60 Hz	9 watts
CONTINENTAL EUROPE	AC 220 V~, 50 Hz	9 watts
U.K. & AUSTRALIA	AC 240 V~, 50 Hz	9 watts
U.S. MILITARY MARKET	AC 110, 120, 220, 240 V Selectable, 50/60 Hz	9 watts
OTHER AREAS	AC 110, 120, 220, 240 V Selectable, 50/60 Hz	9 watts

2. Service Precautions

1. Be sure to place the unit on a level surface when adjusting motor rotation.
2. In servicing, do not use parts other than those specified.
3. Be careful not to damage the motor shaft when repairing the motor unit.
4. When the heat sink (including X815) is removed from the motor board to permit repair of the circuit board, the transistor temperature may increase due to the lack of heat radiation.

3. Features

- Quartz-locked speed control system
- DC type FG servomotor
- Quartz-locked one-row stroboscope
- Oil-damped cueing
- Anti-skating mechanism

4. "How to Operate" (Names and Functions)

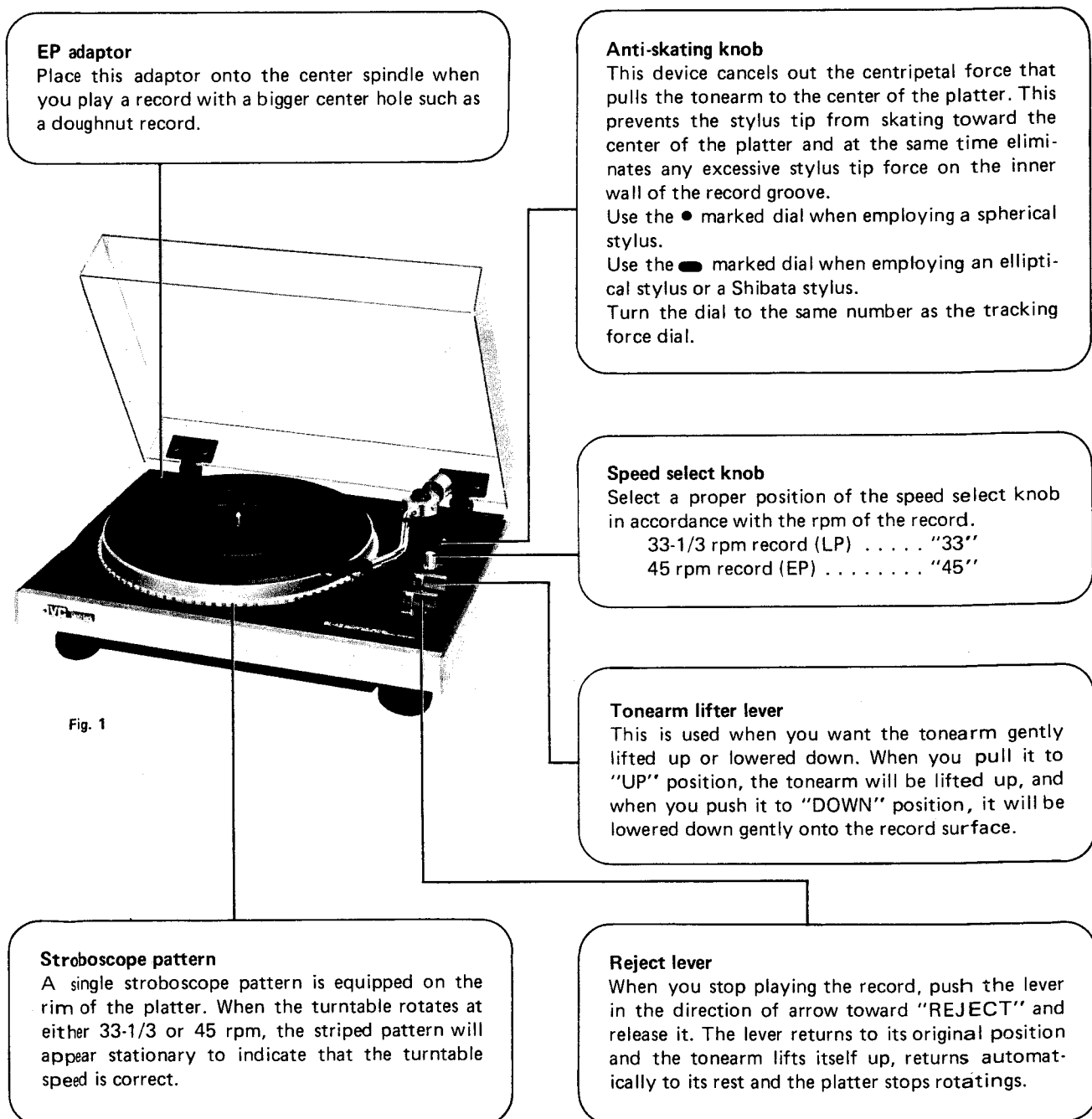

5. Operation of Automatic Mechanism

Change cycle mechanism:

1. During playing, the notch of the main gear position relative to the turntable spindle gear is as shown in Fig. 2.
2. As the projection is away from the engagement, the main gear does not rotate even though the turntable.
3. As playing proceeds, the trip slide moves toward the center of the turntable following the movement of the tonearm as shown in Fig. 3.
4. The engagement is very easy to move as it simply rests on the lower trip. On the music section of the record groove the engagement moves so slightly that it is returned by the tip of the projection. Consequently, the turntable spindle gear does not engage with the main gear and thus does not trigger the auto-return operation.
5. When playing ends and the pick-up cartridge enters the lead-out groove which is spaced out, the engagement advances more than it is returned by the projection. Because of this, the engagement is pressed by the projection as shown in Fig. 4, causing the main gear to turn and engage with the turntable spindle gear. Thus the change cycle is started.
6. During the return operation the engagement and lower trip which have moved are returned to their original position by the reject lever coming into contact with the bottom of the lower trip. At this moment the switch lever operates with the help of the main gear cam, switching off the power just before the rotation should stop. This completes the automatic cycle.

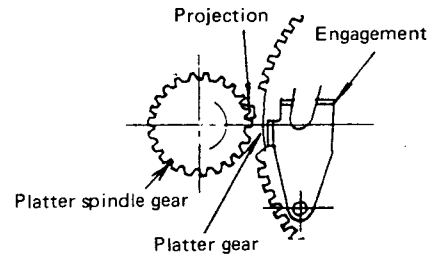

Fig. 2

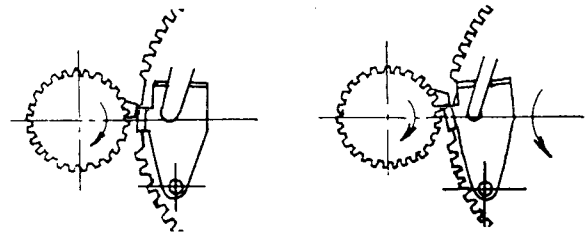

Fig. 3

Fig. 4

Tonearm lift and return mechanism:

1. When the main gear starts to rotate at the end of playing, the return lever rotates under the action of the main gear cam to press the elevator cam. The upward movement of the elevator cam is directly converted into movement of the elevator, lifting up the tonearm. (Fig. 5)
2. The tonearm is returned by the arm lever the end of which presses it as the main gear rotates. (Fig. 6)

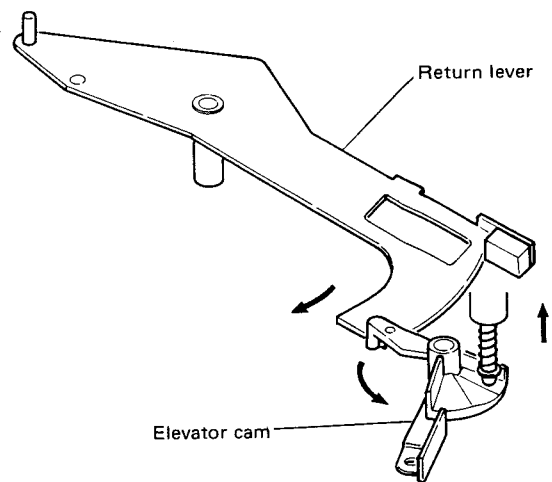

Fig. 5

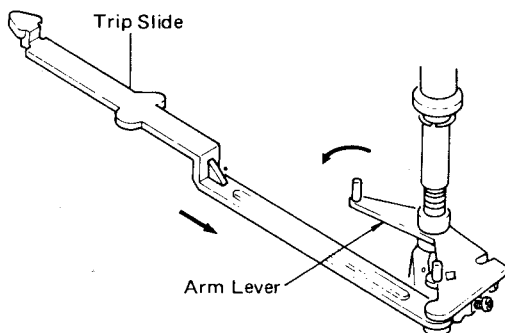

Fig. 6

6. Block Diagrams

6-(1) Servomotor Control System

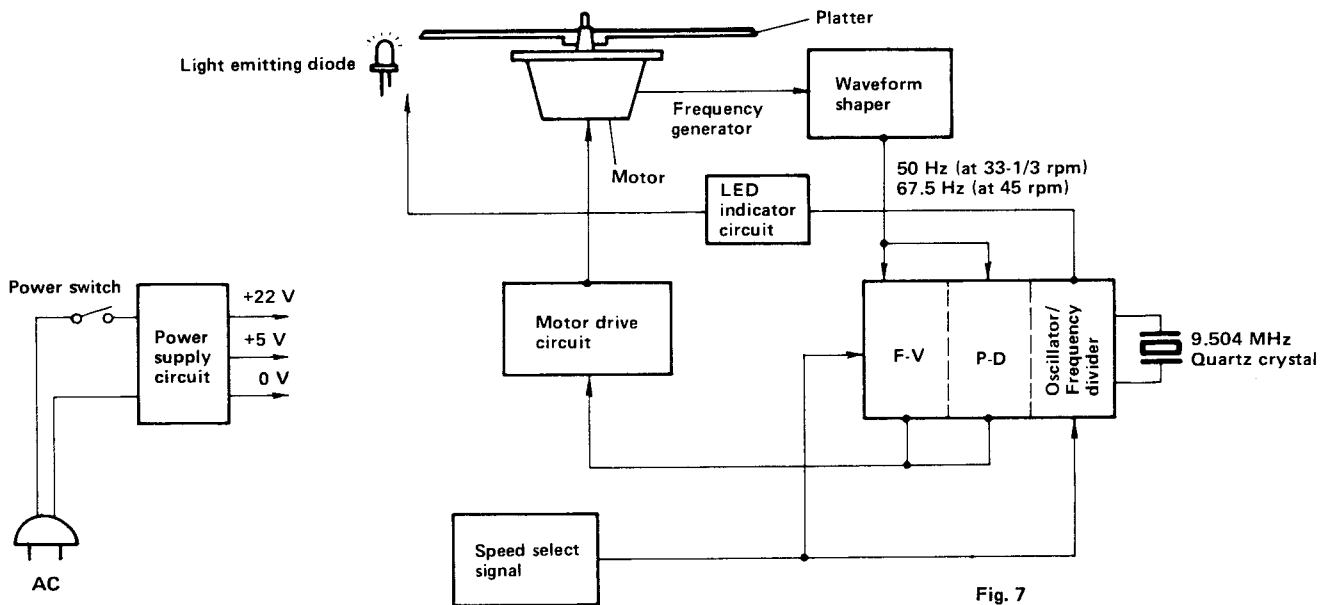

Fig. 7

6-(2) IC802 Integrated Circuits and Waveforms

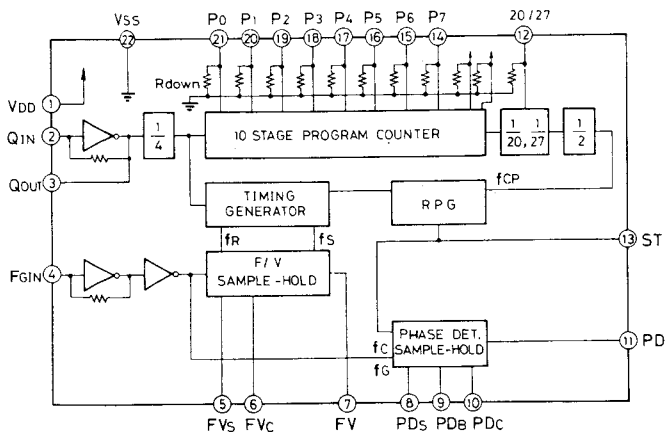

Fig. 8 Block Diagram

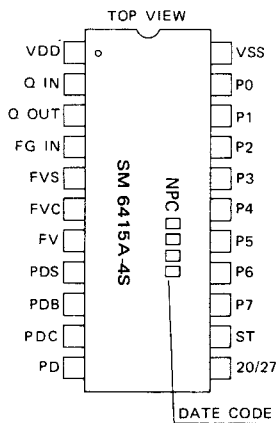

Fig. 9 Pins Location

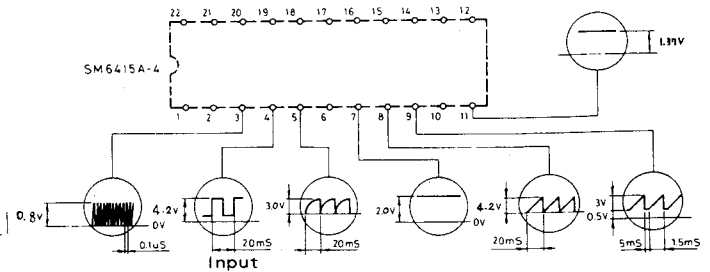

Fig. 10 Waveforms (Pin 1 through Pin 11)

F/V section

Waveform at pin 4.



Waveform at pin 5.

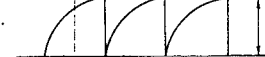

Waveform at pin 7.

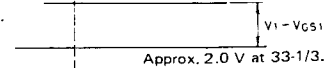

P/D section

Waveform at pin 8.

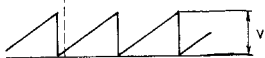

Waveform at pin 11.

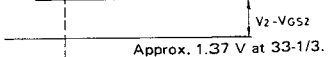

Be sure to obtain the waveform at pin 13 through R820, otherwise the IC may be damaged.

Deviation at lock adjustment (this should be within ± 1 msec.)

Fig. 11 Waveforms (F/V and P/D)

7. Troubleshooting

7-(1) Platter does not rotate

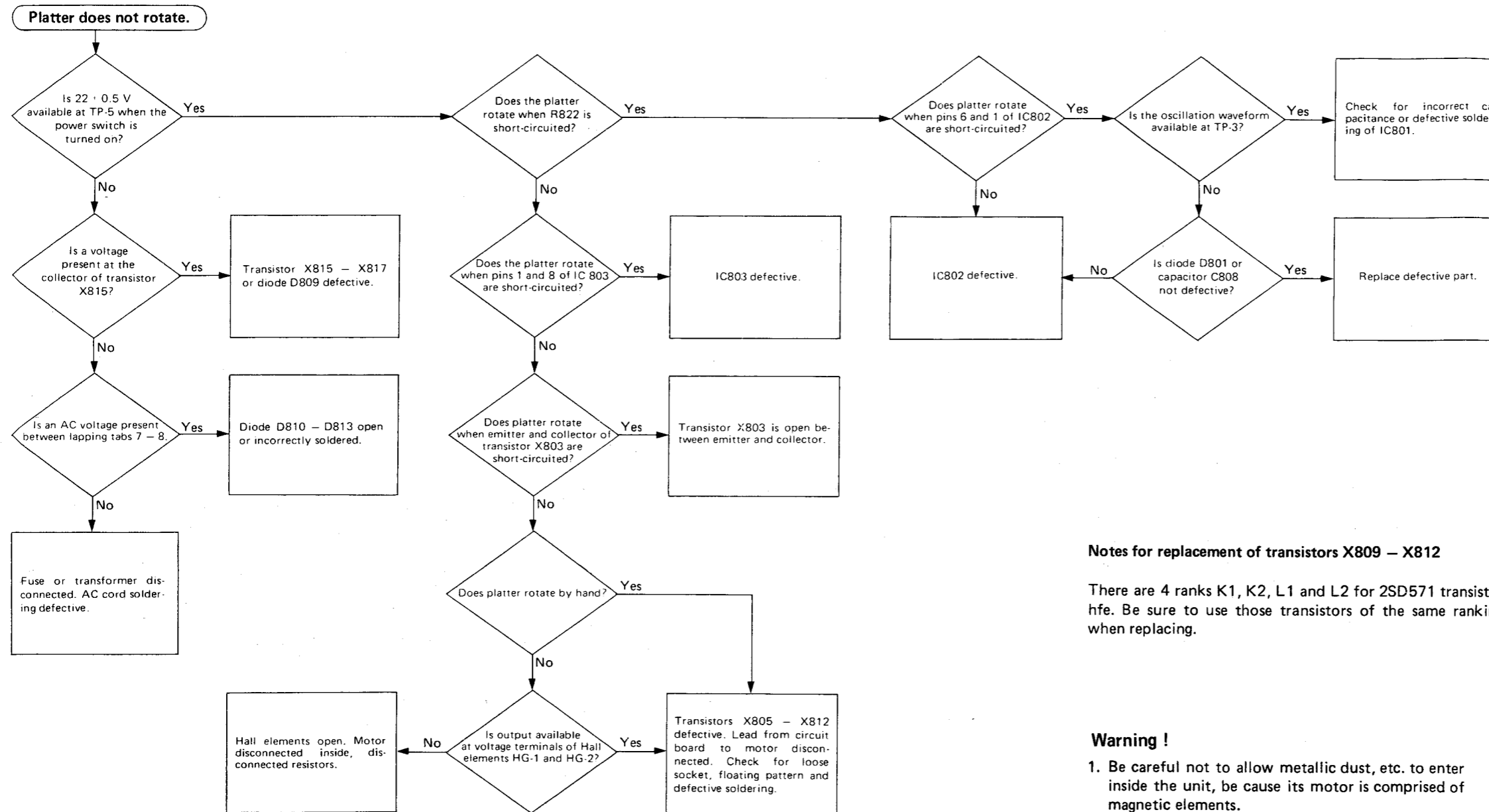

Notes for replacement of transistors X809 - X812

There are 4 ranks K1, K2, L1 and L2 for 2SD571 transistor hfe. Be sure to use those transistors of the same ranking when replacing.

Warning !

1. Be careful not to allow metallic dust, etc. to enter inside the unit, because its motor is comprised of magnetic elements.
2. After replacement of the X813 transistor, apply KE45RTV (silicone adhesive) or an equivalent material around the transistor for thermal conduction.

7-(2) Platter rotates at high speed

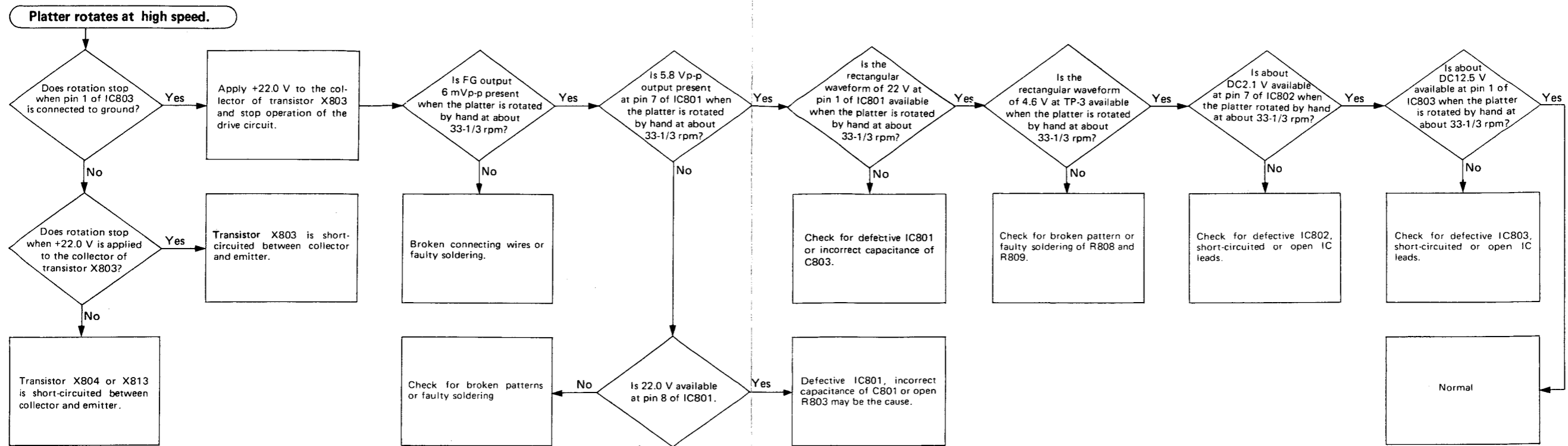

7-(3) Rotation is not locked to the crystal oscillator frequency

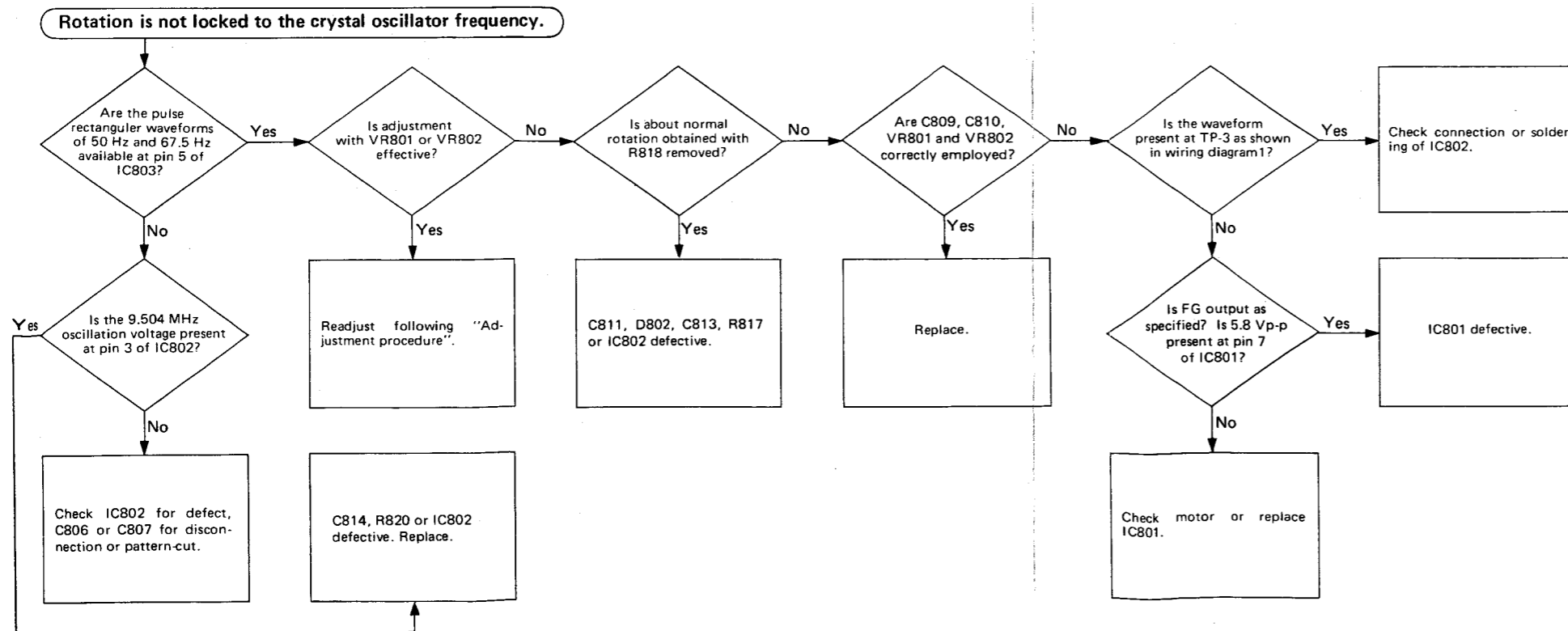

Warning !

1. Be careful not to allow metallic dust, etc. to enter inside the unit, because its motor is comprised of magnetic elements.
2. After replacement of the X813 transistor, apply KE45RTV (silicone adhesive) or an equivalent material around the transistor for thermal conduction.

8. Cartridge Replacement

1. Unscrew the connector nut to remove the headshell.
2. Remove the two long screws on the headshell which hold the cartridge.
3. Connect the lead wires of the headshell to the new cartridge, being careful to match the polarities correctly. Polarity and wire colors are as follows:
 White (+) L Red (+) R
 Blue (-) LE Green (-) RE
4. Attach the cartridge to the headshell squarely, and gently tighten the screws.
5. Set the cueing lever to "DOWN", and then bring the stylus tip to the overhang indicator by sliding the cartridge back and forth. After the adjustment, fix it firmly.
6. After attaching the cartridge, slide the headshell into the tonearm with the connector pin fitting in the groove. Tighten the connector nut.

7. Be sure to adjust the tracking force and lead-in position after replacing the cartridge.

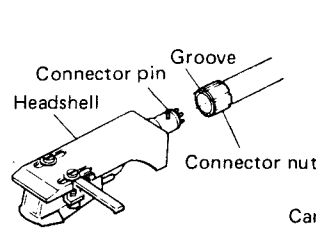

Fig. 12

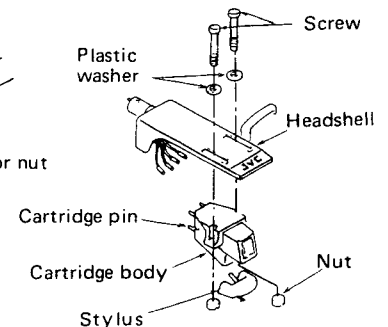

Fig. 13

9. Adjustment Procedures

Servomotor Control Section

9-(1) Power Supply Voltage Check

1. Disconnect the motor socket from the circuit board. Turn the power switch on. (Confirm that the rated voltage is applied to the unit.) Confirm that 22 ± 0.5 V DC is present at TP-5. If the voltage is deviate from that range, adjust with the semi-fixed resistor VR803 (1 k Ω).
2. Confirm that the voltage difference at TP-5 is less than -1V when the platter is stalled with hand.

9-(2) Lock Adjustment

1) With dual beam oscilloscope

1. Connect the motor socket to the circuit board. Connect the dual beam oscilloscope to TP-3, TP-4. Obtain a turntable speed of 45 rpm by setting the speed select switch to 45 and turn the power switch on, then adjust the semi-fixed resistor VR802 (100 k Ω) until the following waveforms are obtained.

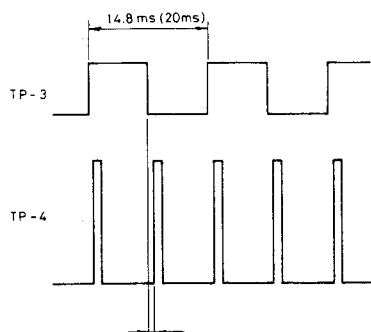

Fig. 14

Adjust to get a difference of within ± 1 msec from TP-4.

2. Obtain a turntable speed of 33-1/3 rpm by setting the speed select switch to 33-1/3, then adjust the semi-fixed resistor VR801 (47 k Ω) until the difference between TP-3 and TP-4 is within ± 1 msec.

2) With single beam oscilloscope

Connect the single beam oscilloscope to TP-3, TP-4 as shown in Fig. 15 below. Adjust until the waveforms shown in Fig. 16 are obtained.

The allowable deviation for adjustment should be within 1 msec. as shown in Fig. 16, Fig. 17.

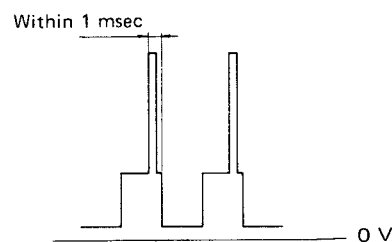
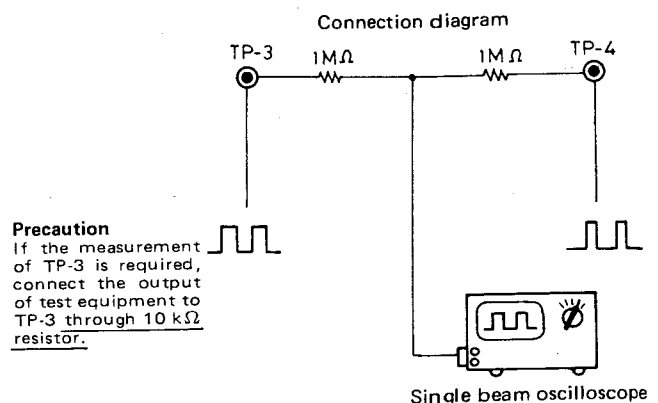

Fig. 15

Fig. 16

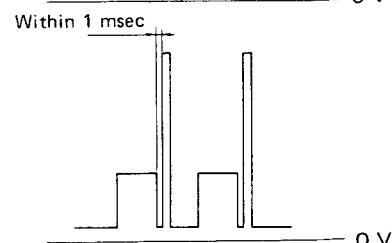

Fig. 17

Tonearm Section

Adjustment

The following adjustments should be performed only when replacing a cartridge or a headshell.

Otherwise, no adjustment is required.

Note: If necessary to replace a cartridge, usage of that headshell exclusive to this unit is recommended.

9-(3) Overhang Adjustment

Loosen the stylus mounting screws and slide the cartridge to adjust the stylus tip position so that tip is coming just over the overhang indicator. (See Fig. 18.)

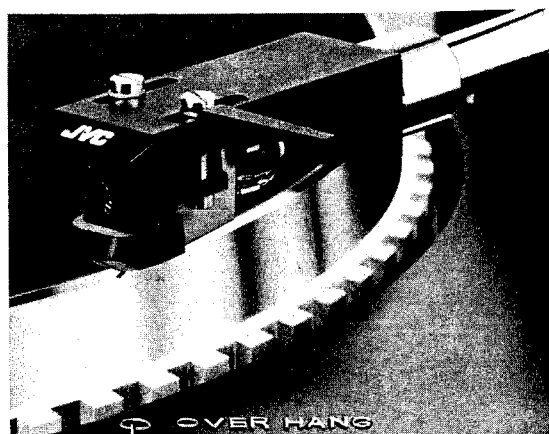

Overhang indicator

Fig. 18

9-(4) Tonearm Lifter Height Adjustment

Adjust the height of tonearm lifter with the adjustment screw so that the distance between the stylus tip and the surface of record is about 6 mm when the stylus is elevated. Turn the height adjustment screw clockwise to lower, and counterclockwise to raise the tonearm lifter level. (See Fig. 19.)



Fig. 19

9-(5) Auto-return (Lead-out) Adjustment

When the pulley has been replaced for a different record or if auto-return functions early, adjust as shown in Fig. 20.

- When change cycle starts too late, turn the screw counterclockwise with a screwdriver.
- When change cycle starts too early, turn the screw clockwise.

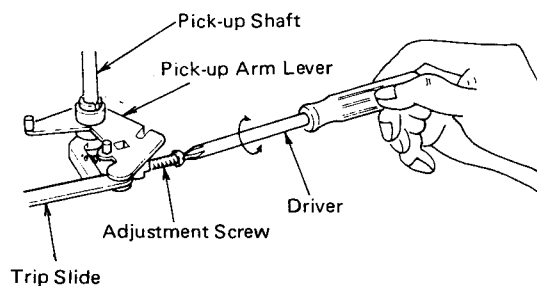

Fig. 20

9-(6) Tracking Force Adjustment

1. Set the anti-skating knob to the "0" mark on the dial.
2. Place an unwarped disc onto the platter.
3. Remove the stylus cover from the stylus.
4. Release the tonearm clamp.
5. Turn the counterweight until the tonearm is balanced.
6. Stop turning the counterweight when the stylus tip is almost touching the disc surface.
7. Return the tonearm to the rest and clamp it.
8. Hold the counterweight at the adjusted position and turn the tracking force dial until the "0" mark is aligned with the index line on the tonearm weight shaft. Turn the counterweight in the B direction until the "2" mark on the dial is aligned with the index line for the model preparing cartridge Z-1S.

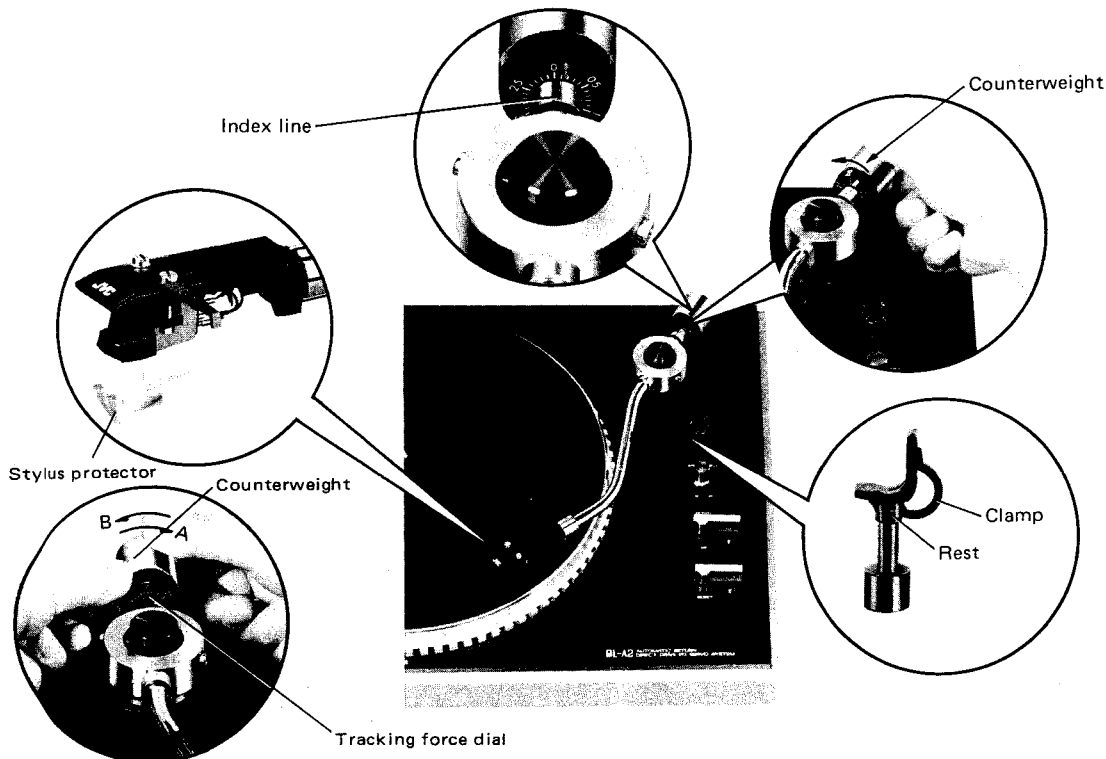

Fig. 21

9-(7) Anti-skating Adjustment

Adjust the anti-skating force according to the cartridge used. Turn the anti-skating knob dial to the same number on the tracking force dial.

Use the ● marked dial when employing a spherical stylus. Use the ● marked dial for an elliptical or a Shibata stylus. Set the "2" of the ● marked dial to the index line since the QL-A2 is provided with a spherical stylus and the tracking force has been adjusted to 2 g.

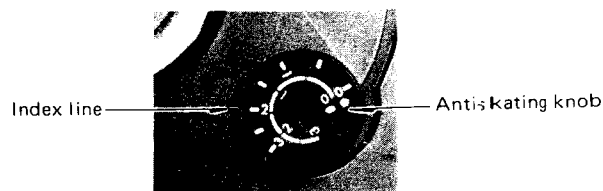

Fig. 22

10. Lubrication

The direct drive motor employed in this unit does not require the lubrication.

11. Exploded Views and Parts List

11-(1) Cabinet and Mechanism Assembly

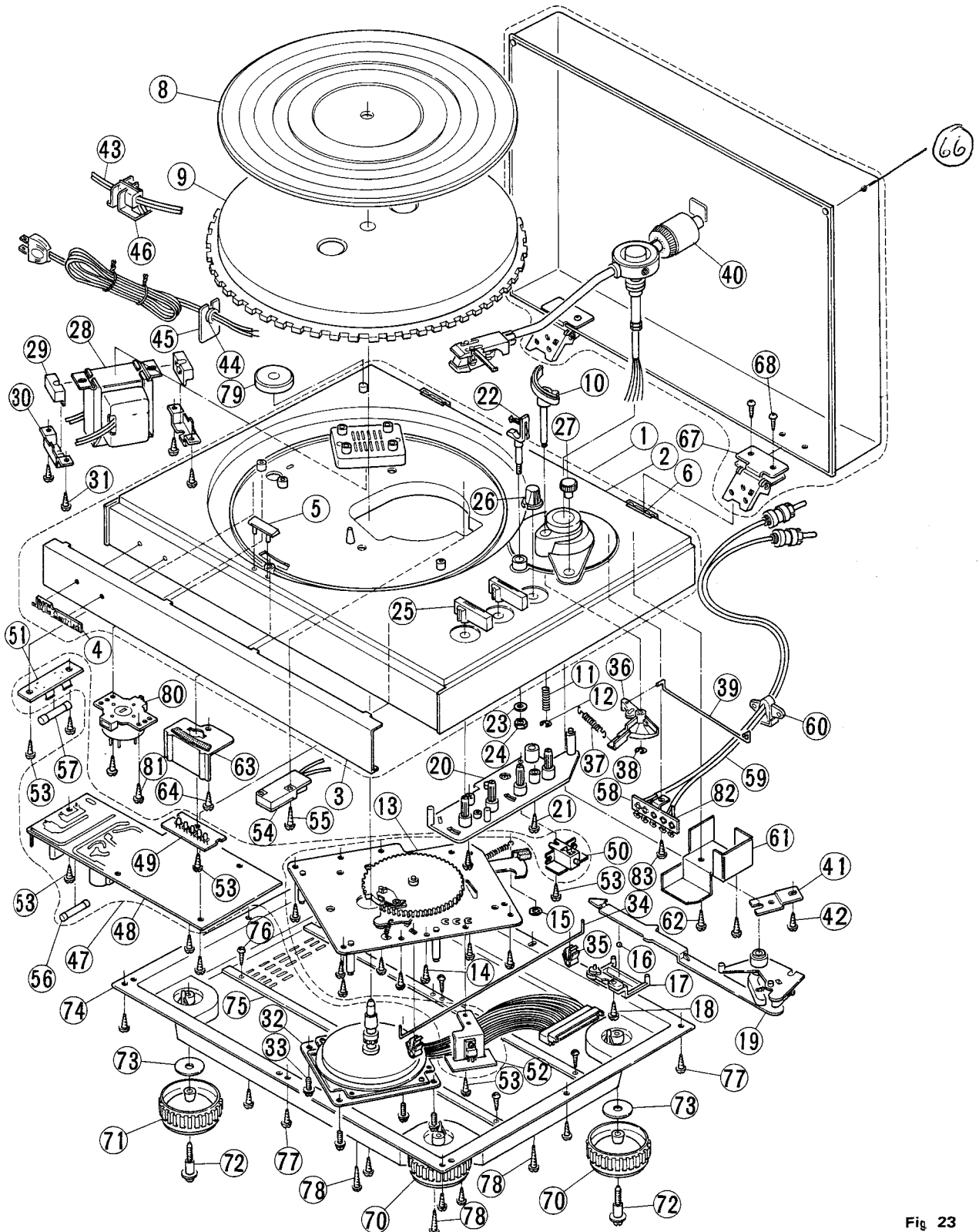

Fig 23

Parts List

Item No.	Part Number	Description	Q'ty
1	E22658-002	Cabinet Ass'y	1
2	E10231-001	Cabinet	1
3	E35463-001	Front Panel	1
4	E65480-001	Mark (JVC Mark)	1
5	E65393-001	Mark	1
6	E65526-001	Cushion	2
7			
8	See page 14.	Platter Cover	1
9	E22659-001	Platter	1
10	E61472-002	Lifter Ass'y	1
11	E61194-001	Spring	1
12	REE3000X	E Ring	1
13	A2001	Base Ass'y (Refer to page 13.)	1
14	SBSB3010Z	Tapping Screw	8
15	G4942-4	Speed Nut	1
16	G41505-1	Steel Ball	1
17	E49873-002	Ball Holder	1
18	SBSB3008Z	Tapping Screw	1
19	E33896-003	Arm Lever Ass'y	1
20	E35458-001	Knob Base Ass'y (Refer to page 13.)	1
21	SBSB3008Z	Tapping Screw	2
22	E60982-002	Arm Rest Ass'y	1
23	WLS4000N	Washer	1
24	NTB4000BS	Nut	1
25	E35471-001	Knob	2
26	E35507-001	"	1
27	E65303-001	" (ANTI)	1
28	See page 14.	Power Transformer Δ	1
29	E61824-001	Cushion	2
30	E61985-001	Spacer	2
31	SBSB3012Z	Tapping Screw	4
32	M938A	Motor	1
33	DPSP4008Z	Ass'y Screw	4
34	E60985-001	Rod	1
35	E49679-001	Rod Holder	2
36	E49595-003	Elevator Cam	1
37	E49596-001	Spring	1
38	REE3000X	E Ring	1
39	E60986-002	Rod	1
40	See page 14.	Tonearm Ass'y	1
41	E65289-001	Stopper	1
42	SBSB3008Z	Tapping Screw	1

Item No.	Part Number	Description	Q'ty
43	See page 14.	Power Cord Δ	1
44	"	Cord Stopper	1
45	"	Cord Stopper Plate	1
46	"	Cord Clamp	1
47	"	P.C. Board Ass'y Δ	1
48	—	P.C. Board Ass'y *	1
49	—	L.E.D. P.C. Board Ass'y *	1
50	— *	Push Switch P.C. Board Ass'y *	1
51	—	Fuse P.C. Board Ass'y *	1
52	—	Transistor P.C. Board Ass'y *	1
53	SBSB3008Z	Tapping Screw	8
54	See page 14.	Micro Switch Δ	1
55	SBSB3016M	Tapping Screw	1
56	See page 14.	Fuse Δ	1
57	"	" Δ	1
58	QML1310-051	Lug Strip Ass'y	1
59	E03697-003	Signal Cord Ass'y	1
60	E33944-001	Cord Stopper	1
61	E65499-001	Shield Cover	1
62	SBSB3008Z	Tapping Screw	2
63	E65291-001	Color Screen	1
64	SBSB3008Z	Tapping Screw	1
65	E35460-001	Dust Cover Ass'y	1
66	E10215-001	Dust Cover	1
67	E61992-002	Hinge Ass'y	2
68	SDSP3008MS	Screw	4
69			
70	See page 14.	Foot Ass'y	2
71	"	"	2
72	E65273-001	Foot Holder	4
73	Q03091-112	Washer	4
74	See page 15.	Bottom Plate Ass'y	1
75	E35457-001	Frame	2
76	SBSB3008Z	Tapping Screw	6
77	SBSB3012M	"	8
78	SBSB3016M	"	3
79	E48820-001	EP-Adaptor	
80	See page 14.	Voltage Selector Δ	
81	SBSB3008Z	Tapping Screw	
82	QML0002-051	Lug Strip Ass'y	
83	SBSB3008Z	Tapping Screw	

*These parts are not supplied separately.

NOTE: Δ SAFETY PARTS

11-(2) Mechanism Base Assembly

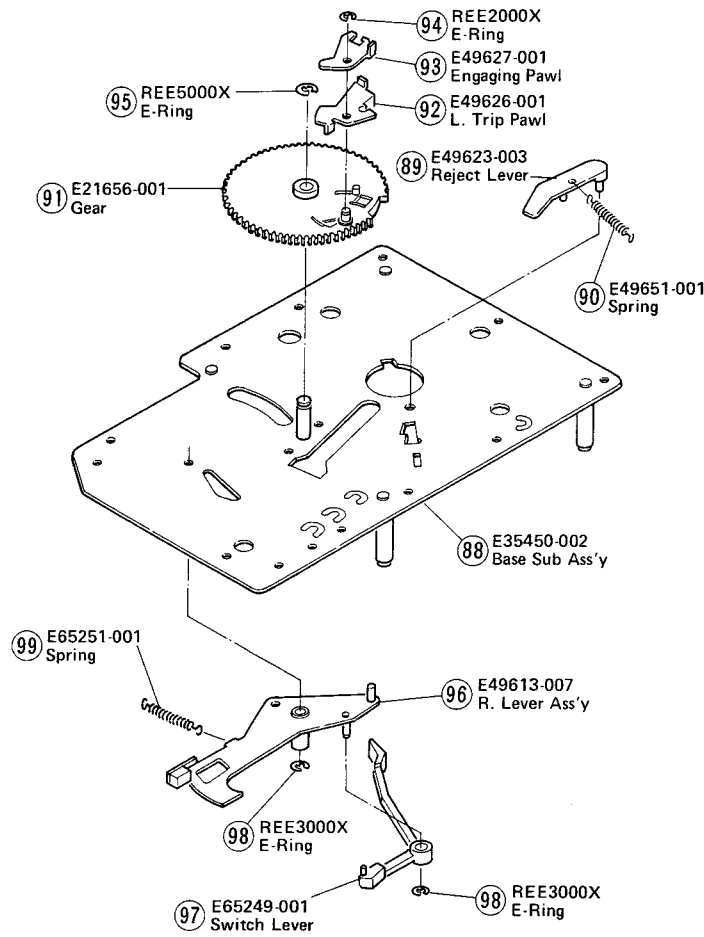

Fig. 24

11-(3) Knob Base Assembly

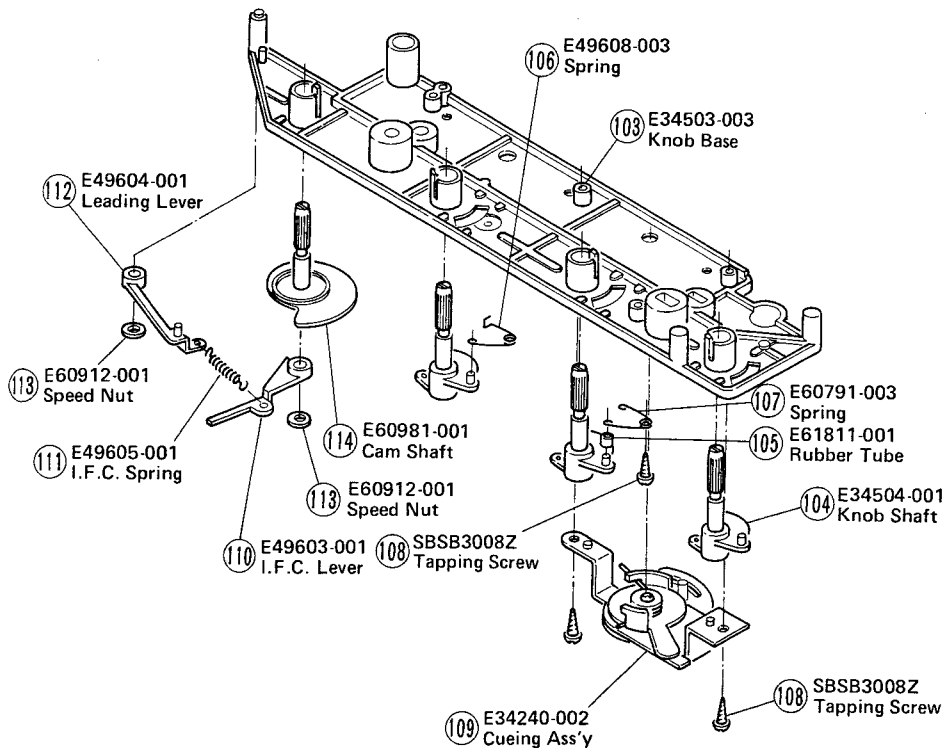

Fig. 25

11-(4) Tonarm Assembly

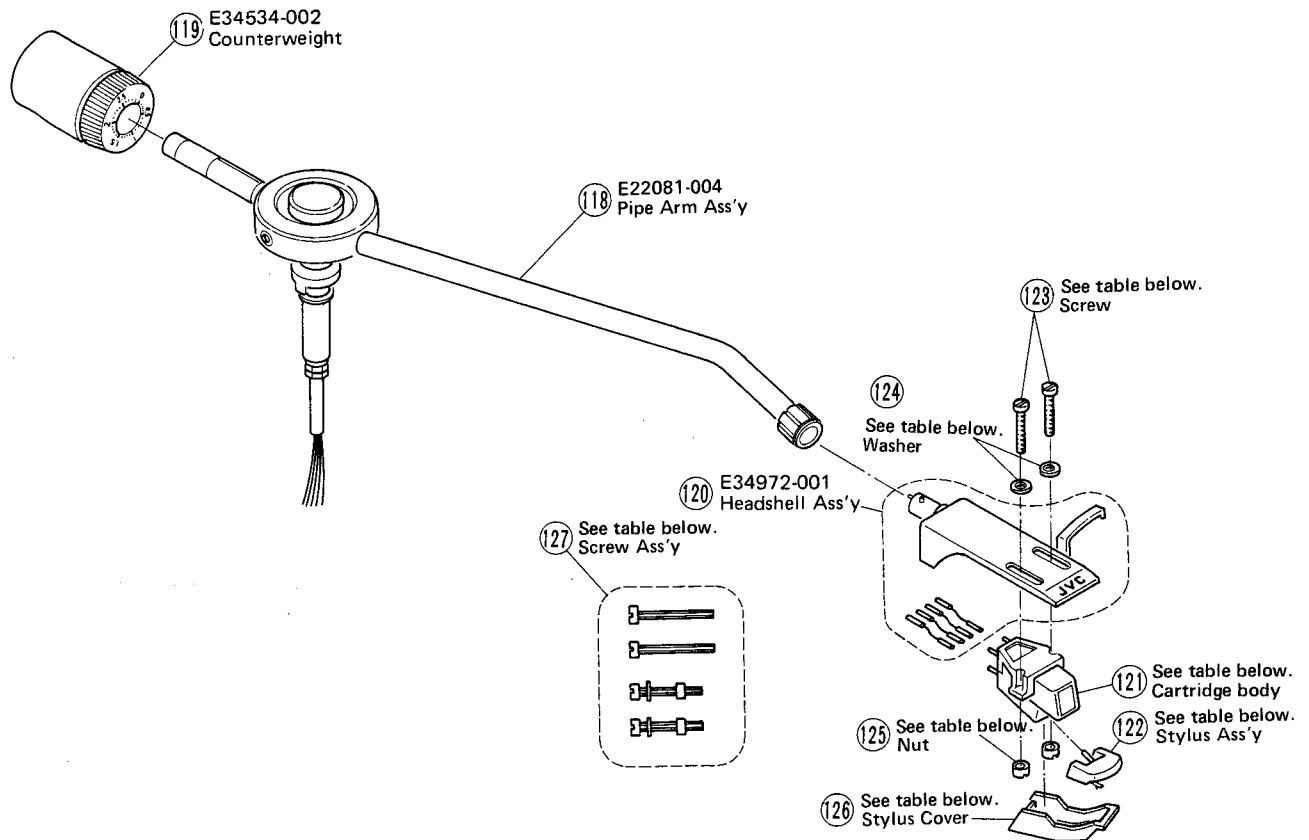

Fig. 26

11-(5) Parts List with Specified Numbers for Designated Areas

Item No.	Description	U.S.A. & Canada	U.S. Military Market and Other Countries	U.K.	Australia	Europe
8	Platter Cover	E22719-002	E22719-001	E22719-001	E22719-001	E22719-001
28	Power Transformer \triangle	E03032-31B	E03032-31D	E03032-31C	E03032-31C	E03032-31C
40	Tonearm Ass'y	ARM-523	MP-185S	ARM-523	MP-185S	MP-185S
43	Power Cord \triangle	QMP1200-244	QMP1200-244	QMP9017-008	QMP2500-200	QMP3910-244
44	Cord Stopper	QHS3876-162	—	—	—	—
45	Cord Stopper Plate	E65465-001	—	—	—	—
46	Cord Clamp	—	A37897	A37897	A37897	A37897
47	P.C. Board Ass'y \triangle	TXX-124B TXX-124C	TXX-124D	TXX-124F	TXX-124E	TXX-124E
	Contact Clip	E45524-001	E45524-001	E48965-002	E48965-002	E48965-002
	P.C. Board (plain)	E22742-002	E22742-001	E22742-001BS	E22742-001	E22742-001
54	Micro Switch \triangle	QSM1V01-001	QSM1V01-001	QSM1V01-022	QSM1V01-022	QSM1V01-022
56	Fuse \triangle	QMF61U1-R50 (0.5A)	QMF60S1-R50 (0.5A)	QMF51A2-R50 (0.5AT)	QMF51A2-R50 (0.5AT)	QMF51A2-R50 (0.5AT)
57	Fuse \triangle	QMF61U1-R50 (0.5A)	QMF60S1-R50 (0.5A)	QMF51A2-R125 (0.125AT)	QMF51A2-R125 (0.125AT)	QMF51A2-R125 (0.125AT)
70	Foot Ass'y	E35118-010 (BLK)	E35118-012 (BRN)	E35118-012 (BRN)	E35118-012 (BRN)	E35118-012 (BRN)
71	Foot Ass'y	E35118-011 (GRY)	E35118-013 (BLU)	E35118-013 (BLU)	E35118-013 (BLU)	E35118-013 (BLU)
74	Bottom Plate Ass'y	E22342-007	E22342-008	E22342-008	E22342-008	E22342-008
80	Voltage Selector \triangle	—	QSR0085-001	—	—	—
121	Cartridge Body	—	MD-1025	—	MD-1025	MD-1025
122	Stylus Ass'y	—	DT-Z1S	—	DT-Z1S	DT-Z1S
123	Screw	—	EG83456	—	EG83456	EG83456
124	Washer	—	EG82971	—	EG82971	EG82971
125	Nut	—	E60503-001	—	E60503-001	E60503-001
126	Stylus Cover	—	E34268-001	—	E34268-001	E34268-001
127	Screw Ass'y	E61153-003	—	E61153-003	—	—

NOTE: \triangle SAFETY PARTS

12. Connection Diagram of TXX-124

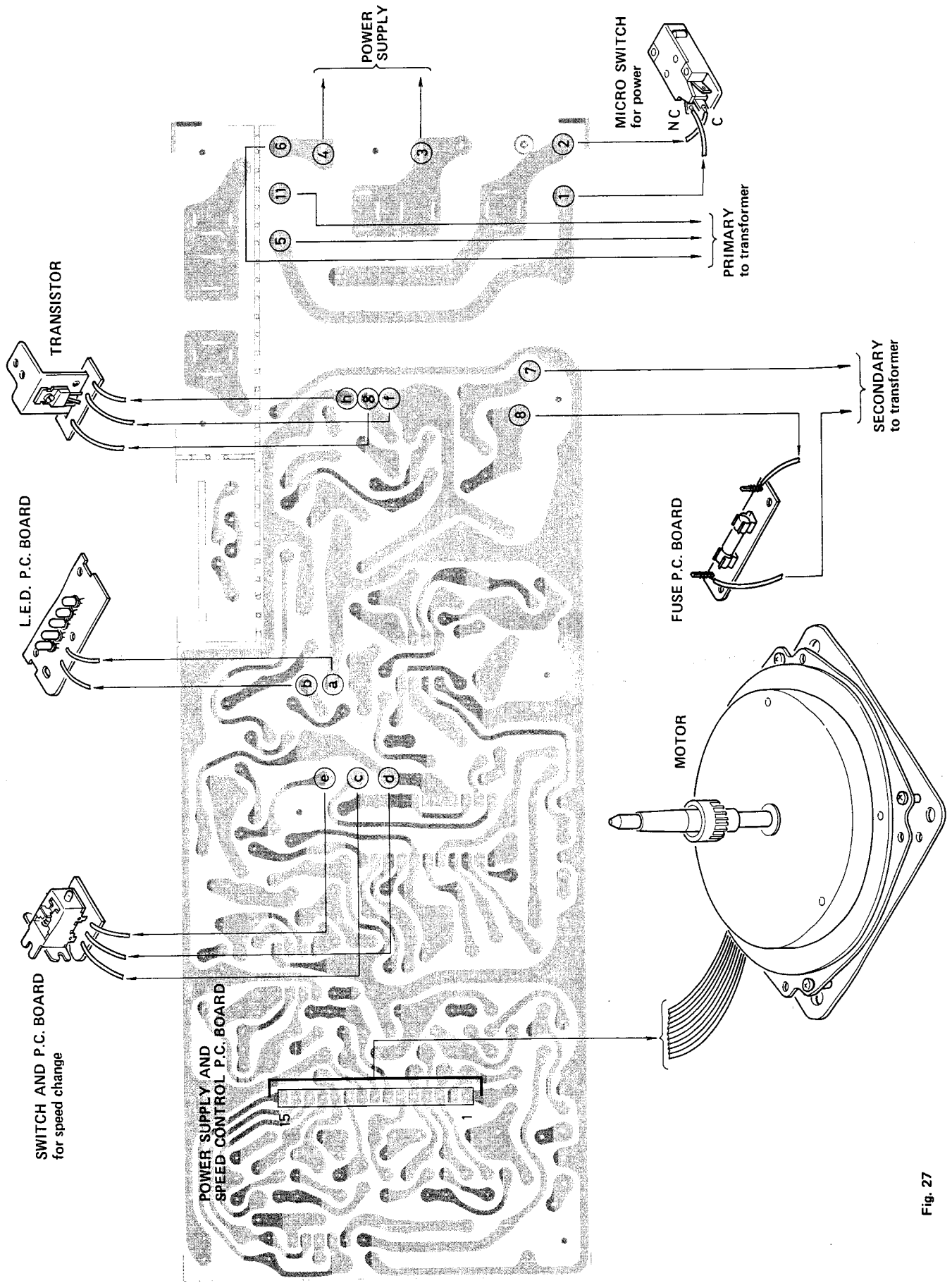
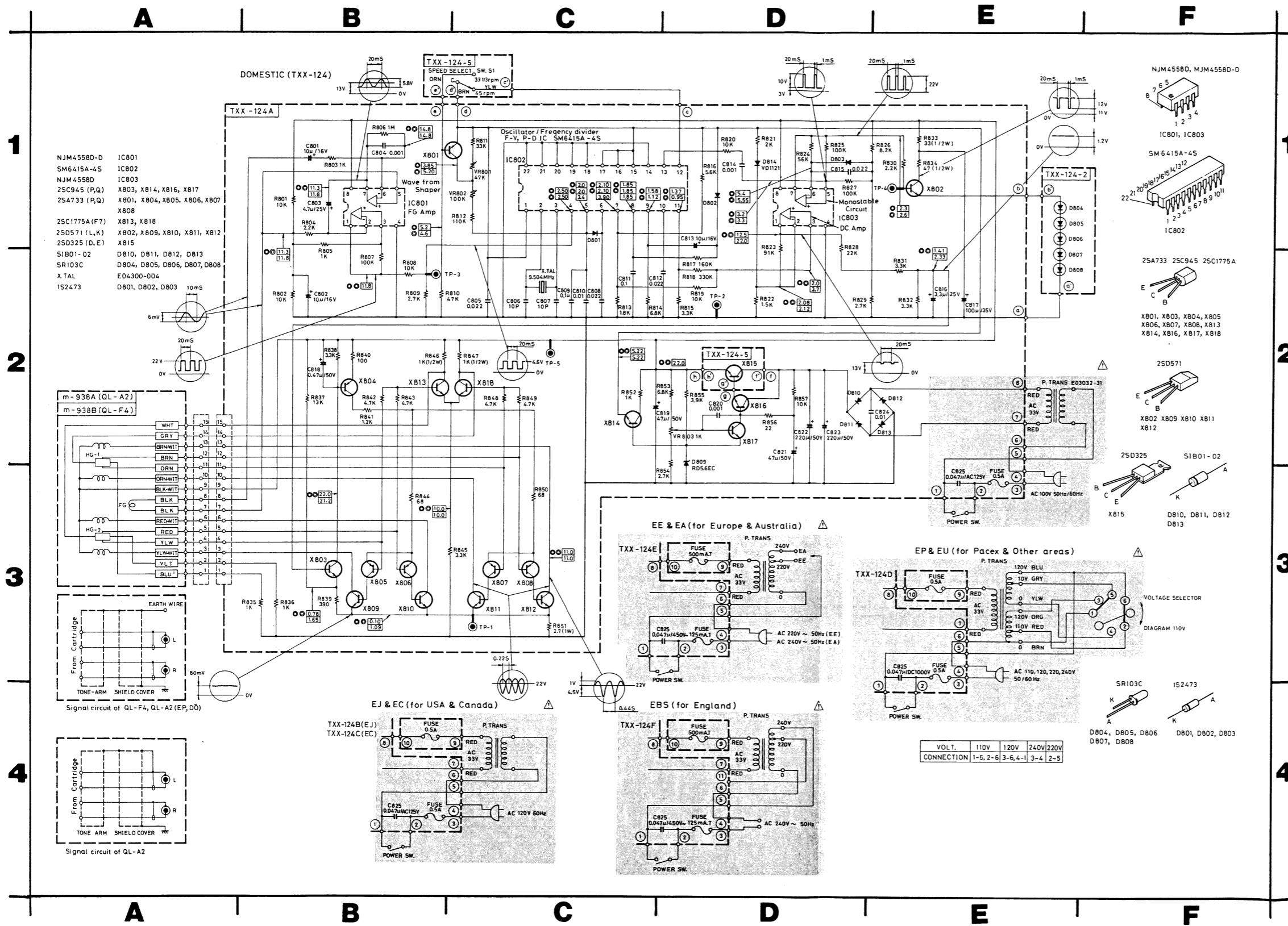
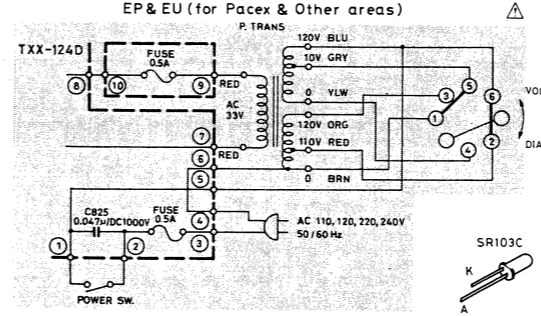
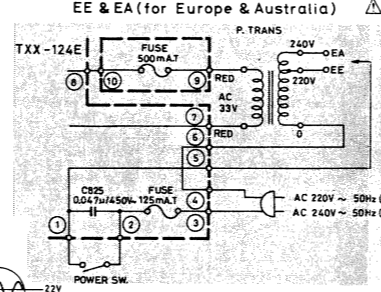
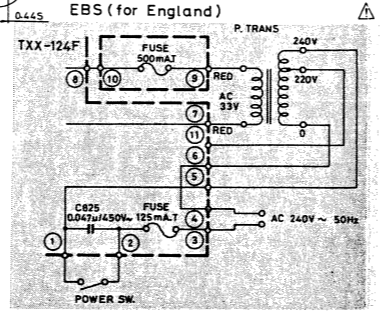
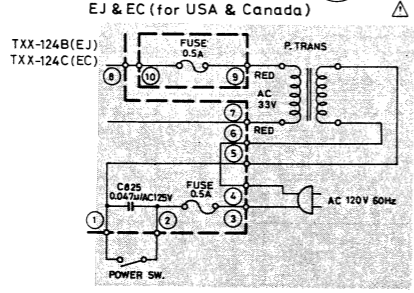
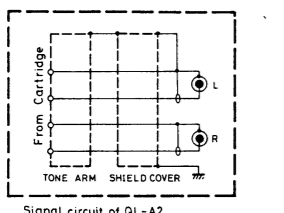
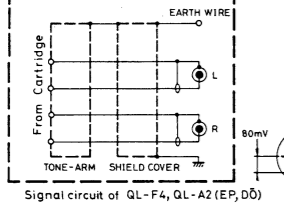
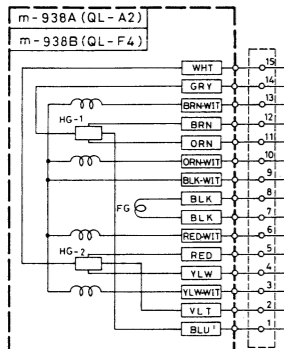

Fig. 27

13. TXX-124 Schematic Diagram



- NJM4558D-D IC801
- SM6415A-4S IC802
- NJM4558D IC803
- 2SC945 (P,Q) X803, X814, X816, X817
- 2SA733 (P,Q) X801, X804, X805, X806, X807, X808
- 2SC1775A (F7) X813, X818
- 2SD571 (L,K) X802, X809, X810, X811, X812
- 2SD325 (D,E) X815
- SIB01-02 D810, D811, D812, D813
- SR103C D804, D805, D806, D807, D808
- X.TAL E04300-004
- 1S2473 D801, D802, D803



VOLT.	110V	120V	240V	220V
CONNECTION	1-5, 2-6	3-6, 4-1	3-4	2-5

- Notes:**
- The voltage indicated in \square is measured by a tester having an internal impedance of $33\text{ k}\Omega/V$.
 - \bullet \square 33-1/3 rpm
 - \odot \square 45 rpm
 - \square When locked
 - X809 through X812 should be of the same rank. (There are four different rankings available on the market as follows: 2SD571 K1, K2, L1 and L2. Be sure to use only one rank of those transistors being replaced.)
 - When replacing either of these transistors 2SC1775A (F7), X813 or X818, they should be replaced together as a pair both being of the same rank.
 - indicates positive B power supply.
 - indicates signal path.
 - When replacing the parts in the darkened area and those marked with \triangle , be sure to use the designated parts to ensure safety.
 - This is the standard circuit diagram. The design and contents are subject to change without notice.

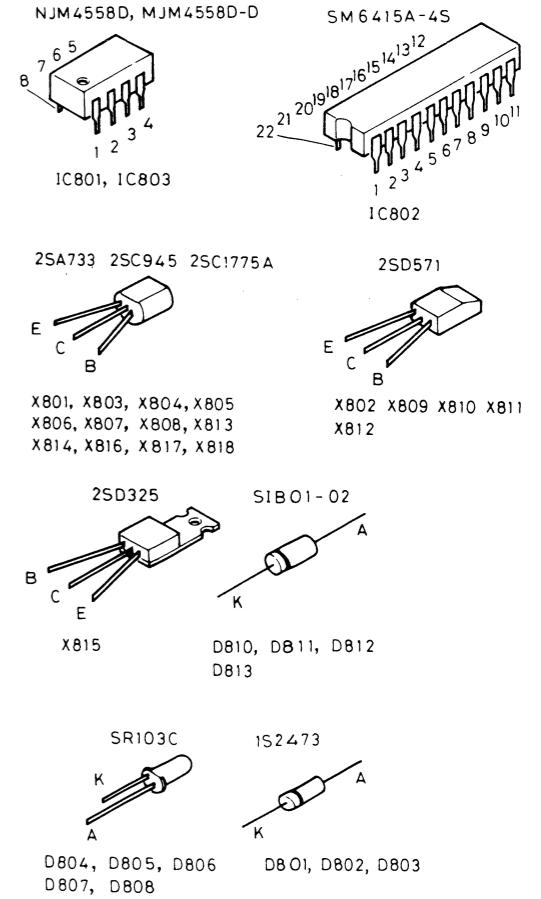

Printed Circuit Board Ass'y Location

P.C. Board Ass'y	Description	Page
TXX-124	Servomotor Control P.C. Board Ass'y	17

Warning!

- Be careful not to allow metallic dust, etc. to enter inside the unit, because its motor is comprised of magnetic elements.
- After replacement of the X813 transistor, apply KE45RTV (silicone adhesive) or an equivalent material around the transistor for thermal conduction.

14. TXX-124 Printed Circuit Board Ass'y and Parts List

The assembly varies according to the area where the units is sold. Refer to the table shown on page 28.

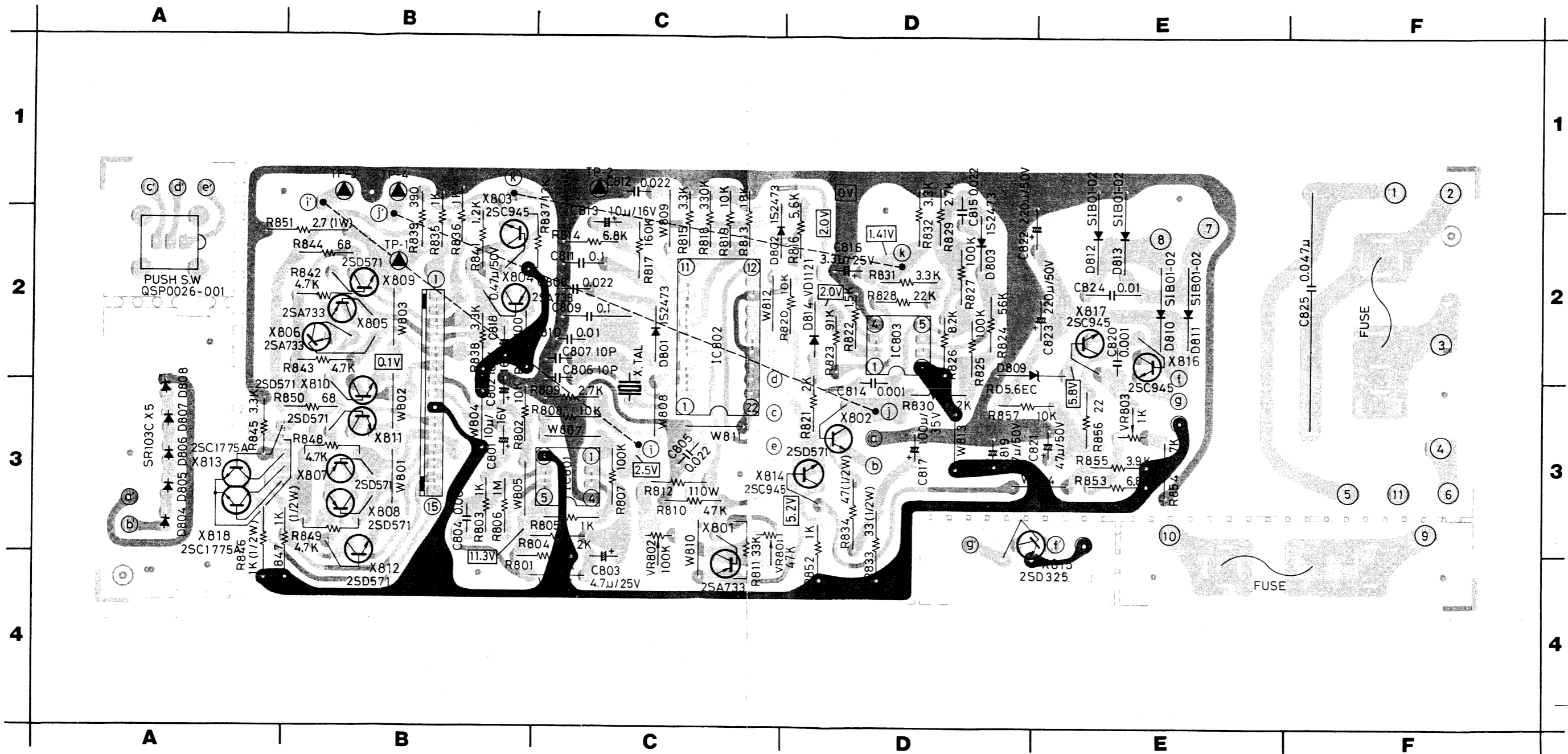

Notes:

1. Voltage values in are measured with a tester (impedance 33 kΩ/V) without a signal applied to the unit.
2. indicates positive B power supply.
- indicates ground.
- indicates the others.

Warning !

1. Be careful not to allow metallic dust, etc. to enter inside the unit, because its motor is comprised of magnetic elements.
2. After replacement of the X813 transistor, apply KE45RTV (silicone adhesive) or an equivalent material around the transistor for thermal conduction.

Transistors

Item No.	Part Number	Rating		Description	Maker
		Pc	fT		
X801	2SA733 (P, Q)	250 mW	180 MHz	Silicon	NEC
X802	2SD571 (L, K)	800 mW	110 MHz	"	"
X803	2SC945 (P, Q)	250 mW	250 MHz	"	"
X804	2SA733 (P, Q)	"	180 MHz	"	"
X805	2SA733 (P, Q)	"	"	"	"
X806	2SA733 (P, Q)	"	"	"	"
X807	2SA733 (P, Q)	"	"	"	"
X808	2SA733 (P, Q)	"	"	"	"
X809	2SD571 (L, K)	800 mW	110 MHz	"	"
X810	2SD571 (L, K)	"	"	"	"
X811	2SD571 (L, K)	"	"	"	"
X812	2SD571 (L, K)	"	"	"	"
X813	2SC1775A (F7)	300 mW	200 MHz	"	Hitachi
X814	2SC945 (P, Q)	250 mW	250 MHz	"	NEC
X815	2SD325 (D, E)	10 W	8 MHz	"	Sanyo
X816	2SC945 (P, Q)	250 mW	250 MHz	"	NEC
X817	2SC945 (P, Q)	"	"	"	"
X818	2SC1775A (F7)	300 mW	200 MHz	"	Hitachi

Integrated Circuits

Item No.	Part Number	Rating	Description	Maker
IC801	NJM4558D-D		IC	Shin Nippon Musen
IC802	SM6415A-4S		"	Nihon Precision Circuit
IC803	NJM4558D		"	Shin Nippon Musen

Diodes

Item No.	Part Number	Rating	Description	Maker
D801	1S2473		Silicon	Toyo Dengu
D802	1S2473		"	"
D803	1S2473		"	"
D804	SR103C		L.E.D.	NEC
D805	SR103C		"	"
D806	SR103C		"	"
D807	SR103C		"	"
D808	SR103C		"	"
D809	RD5.6EC		Zener	"
D810	SIB01-02		Silicon	Kyodo Denki
D811	SIB01-02		"	"
D812	SIB01-02		"	"
D813	SIB01-02		"	"
D814	VD1121		Varistor	NEC

Capacitors

Item No.	Part Number	Rating		Description
C801	QEW51CA-106	10 μ F	16 V	Electrolytic
C802	QEW51CA-106	"	"	"
C803	QEW51EA-475	4.7 μ F	25 V	"
C804	QCF31HP-102	1000 pF	50 V	Ceramic
C805	QCF31HP-223	0.022 μ F	"	"
C806	QCT25UJ-100	10 pF		"
C807	QCT25UJ-100	"		"
C808	QFM31HK-223	0.022 μ F	50 V	Mylar
C809	AWS104J50	0.1 μ F	"	Polypropylene
C810	QFM31HK-103	0.01 μ F	"	Mylar
C811	QFM31HK-104	0.1 μ F	"	"
C812	QCF31HP-223	0.022 μ F	"	Ceramic
C813	QEW51CA-106	10 μ F	16 V	Electrolytic
C814	QCF31HP-102	1000 pF	50 V	Ceramic
C815	QFM31HK-223	0.022 μ F	"	Mylar
C816	QEB51EM-335	3.3 μ F	25 V	Low leak current electrolytic
C817	QEW51VA-107	100 μ F	35 V	Electrolytic
C818	QEW51HA-474	0.47 μ F	50 V	"
C819	QEW51HA-476	47 μ F	"	"
C820	QCF31HP-102	1000 pF	"	Ceramic
C821	QEW51HA-476	47 μ F	"	Electrolytic
C822	QEW51HA-227	220 μ F	"	"
C823	QEW51HA-227	"	"	"
C824	QCF12HP-103	0.01 μ F	500 V	Ceramic
C825	QFA72BM-473	0.047 μ F	125 V	Metallized polypropylene (For TXX-124C)
C825	QFH53AM-473M	"	1000 V	" (For TXX-124D)
C825	QFH72BM-473M	"	125 V	" (For TXX-124B)
C825	QFZ9007-473	"	425 V	Film (For TXX-124E)
C825	QFZ9007-473BS	"	"	" (For TXX-124F)

Resistors

Item No.	Part Number	Rating		Description
R801	QRD141J-103SY	10 k Ω	1/4 W	Carbon
R802	QRD141J-103SY	"	"	"
R803	QRD141J-102SY	1 k Ω	"	"
R804	QRD141J-222SY	2.2 k Ω	"	"
R805	QRD141J-102SY	1 k Ω	"	"
R806	QRD141J-105SY	1 M Ω	"	"
R807	QRD141J-104SY	100 k Ω	"	"
R808	QRD141J-103SY	10 k Ω	"	"
R809	QRD141J-272SY	2.7 k Ω	"	"
R810	QRD141J-473SY	47 k Ω	"	"
R811	QRV144F-3302	33 k Ω	"	Metal film
R812	QRV144F-1103	110 k Ω	"	"
R813	QRD141J-182SY	1.8 k Ω	"	Carbon
R814	QRD141J-682SY	6.8 k Ω	"	"
R815	QRD141J-332SY	3.3 k Ω	"	"
R816	QRD141J-562SY	5.6 k Ω	"	"
R817	QRD141J-164SY	160 k Ω	"	"
R818	QRD141J-334SY	330 k Ω	"	"
R819	QRD141J-103SY	10 k Ω	"	"
R820	QRD141J-103SY	"	"	"

Resistors

Item No.	Part Number	Rating		Description	Maker
R821	QRD141J-202SY	2 k Ω	1/4 W	Carbon	
R822	QRD141J-152SY	1.5 k Ω	"	"	
R823	QRD141J-913SY	91 k Ω	"	"	
R824	QRD141J-563SY	56 k Ω	"	"	
R825	QRD141J-104SY	100 k Ω	"	"	
R826	QRD141J-822SY	8.2 k Ω	"	"	
R827	QRD141J-104SY	100 k Ω	"	"	
R828	QRD141J-223SY	22 k Ω	"	"	
R829	QRD141J-272SY	2.7 k Ω	"	"	
R830	QRD141J-222SY	2.2 k Ω	"	"	
R831	QRD141J-332SY	3.3 k Ω	"	"	
R832	QRD141J-332SY	"	"	"	
R833	QRG129J-330	33 Ω	1/2 W	Oxide metal film	
R834	QRG129J-470	47 Ω	"	"	
R835	QRD141J-102SY	1 k Ω	1/4 W	Carbon	
R836	QRD141J-102SY	"	"	"	
R837	QRD141J-133SY	13 k Ω	"	"	
R838	QRD141J-332SY	3.3 k Ω	"	"	
R839	QRD141J-391SY	390 Ω	"	"	
R840	QRD141J-101SY	100 Ω	"	"	
R841	QRD141J-122SY	1.2 k Ω	"	"	
R842	QRD141J-472SY	4.7 k Ω	"	"	
R843	QRD141J-472SY	"	"	"	
R844	QRD141J-680SY	68 Ω	"	"	
R845	QRD141J-332SY	3.3 k Ω	"	"	
R846	QRG129J-102	1 k Ω	1/2 W	Oxide metal film	
R847	QRG129J-102	"	"	"	
R848	QRD141J-472SY	4.7 k Ω	1/4 W	Carbon	
R849	QRD141J-472SY	"	"	"	
R850	QRD141J-680SY	68 Ω	"	"	
R851	QRX017J-2R7S	2.7 Ω	1 W	Uninflammable	
R852	QRD141J-102SY	1 k Ω	1/4 W	Carbon	
R853	QRD141J-682SY	6.8 k Ω	"	"	
R854	QRD141J-272SY	2.7 k Ω	"	"	
R855	QRD141J-392SY	3.9 k Ω	"	"	
R856	QRD141J-220SY	22 Ω	"	"	
R857	QRD141J-103SY	10 k Ω	"	"	
VR801	RVG0911H306-473	47 k Ω		Variable	
VR802	RVG0911H306-104	100 k Ω		"	
VR803	QVP4AOB-102	1 k Ω		"	

Others

Item No.	Part Number	Rating	Description
	E04300-004		Quartz crystal
	E41541-21		Bushing
	See page 14.		Contact clip
	E48965-002		Fuse clip
	E61466-003		Heat sink
	QSP0026-001		Push switch
	See page 14.		P.C. Board (plain)

15. Packing Materials and Part Numbers

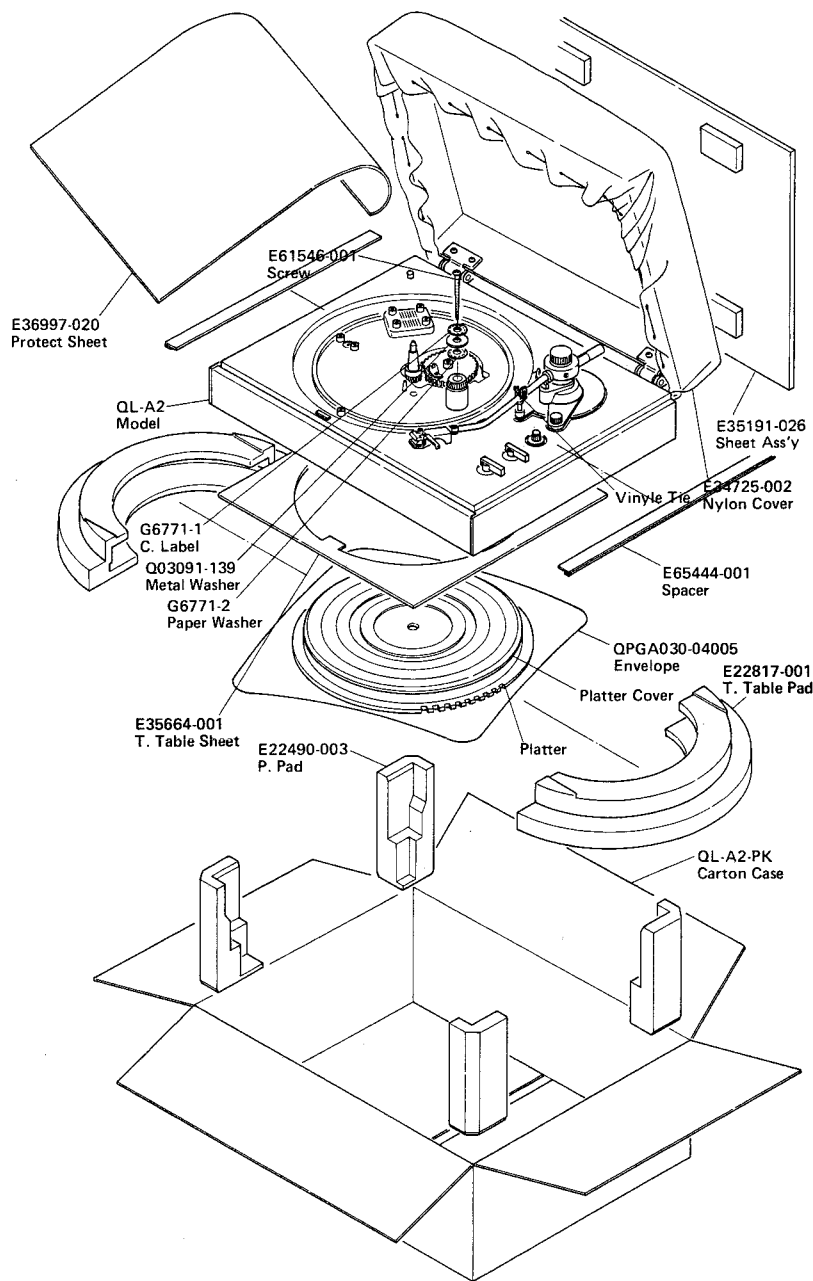
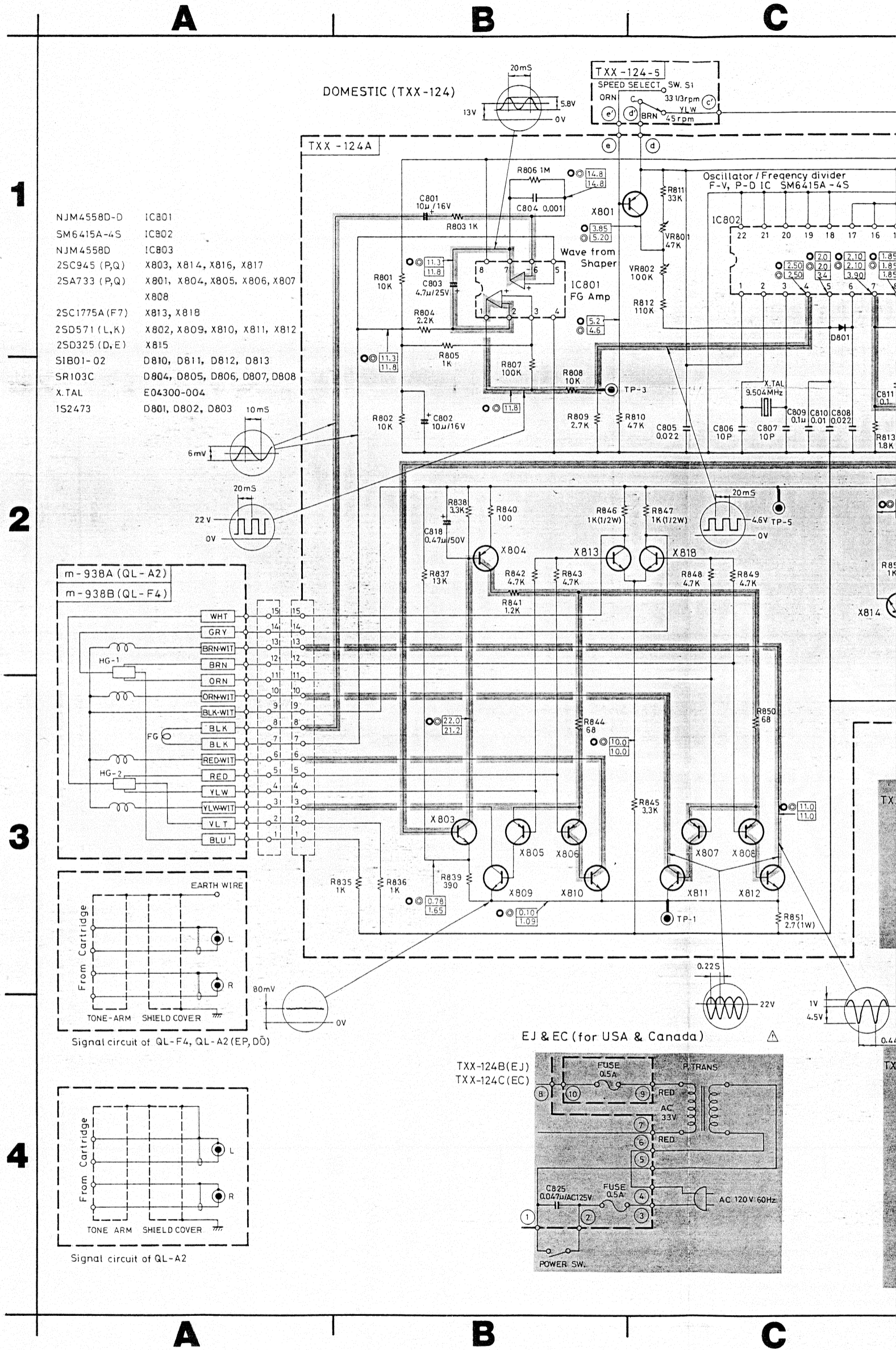

Fig. 28

16. Accessories List

Description	U.S.A.	Canada	Europe	U.K.	Australia	U.S. Military Market and Other Countries
Instruction Book	E30580-650A	E30580-650A	E30580-650A	E30580-650A	E30580-650A	E30580-650A
Warranty Card	BT20032	BT20025		BT20013B	BT20029	BT20032 (U.S. Military Market)
Do It Better	BT20024B	—	—	—	—	—
Service Procedure	BT20023	—	—	—	—	—
Envelope	E64207-001	E64207-001	E64207-001	E64207-001	E64207-001	E64207-001
EP Adaptor	E48820-001	E48820-001	E48820-001	E48820-001	E48820-001	E48820-001
Screw Ass'y	—	—	E61153-003	E61153-003	E61153-003	E61153-003
Siemens Plug	—	—	—	—	—	E04056

17. QL-A2 Schematic Diagram



Printed Circuit Board Ass'y Location

P.C. Board Ass'y	Description	Page
TXX-124	Servomotor Control P.C. Board Ass'y	17

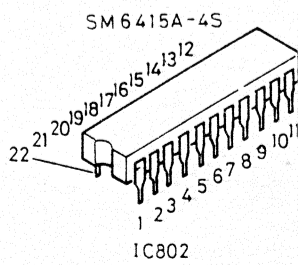

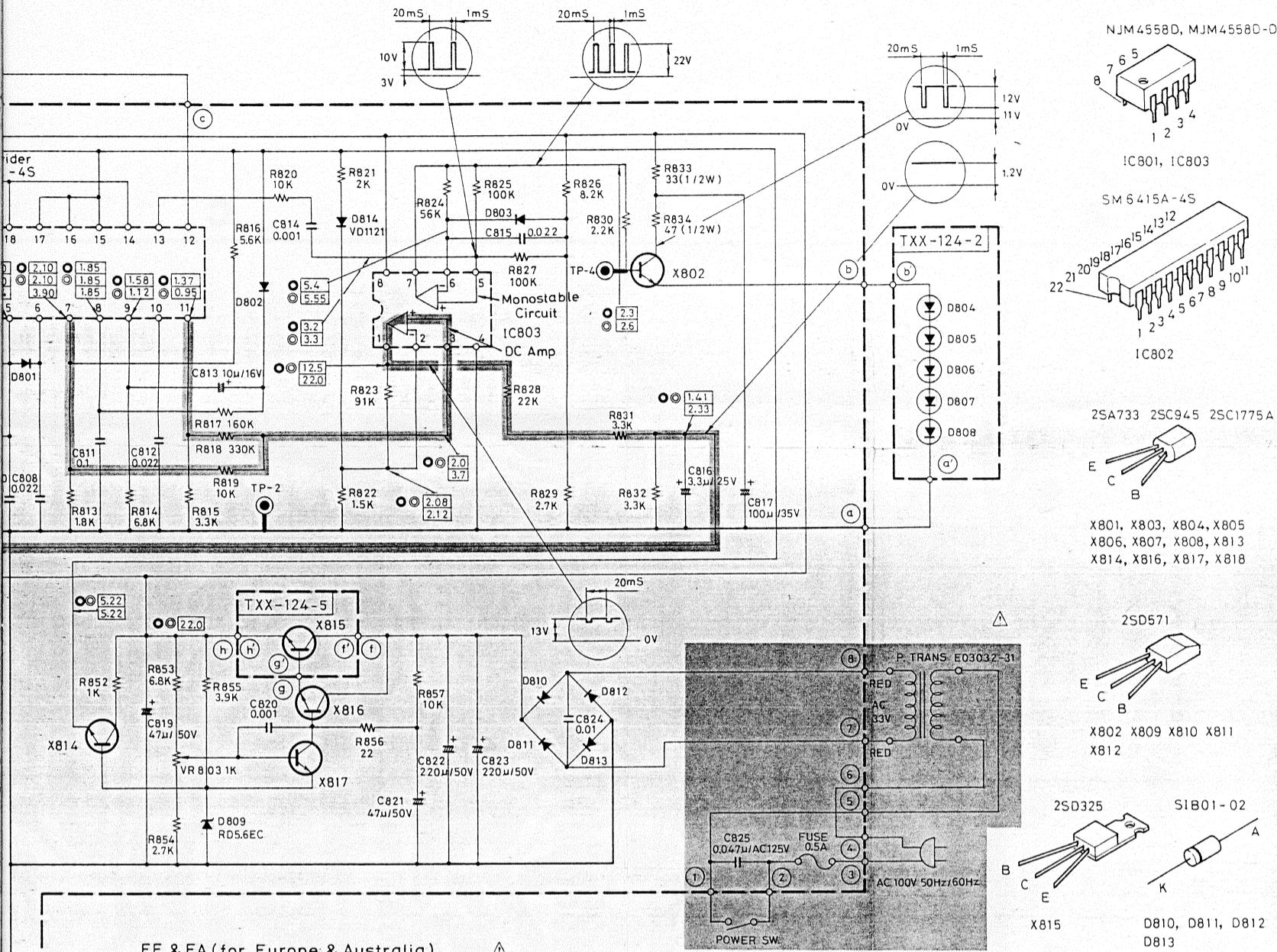
D**E****F****Notes:**

- The voltage indicated in \square is measured by a tester having an internal impedance of 33 k Ω /V.
 - \bullet \square 33-1/3 rpm
 - \odot \square 45 rpm
 - \square When locked
- X809 through X812 should be of the same rank. (There are four different rankings available on the market as follows: 2SD571 K1, K2, L1 and L2. Be sure to use only one rank of those transistors being replaced.)
- When replacing either of these transistors 2SC1775A(F7), X813 or X818, they should be replaced together as a pair both being of the same rank.
- --- indicates positive B power supply.
- --- indicates signal path.
- When replacing the parts in the darkened area \blacksquare and those marked with \triangle , be sure to use the designated parts to ensure safety.
- This is the standard circuit diagram. The design and contents are subject to change without notice.

1**2****3****4**

NJM4558D, MJM4558D-D

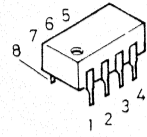

IC801, IC803

SM6415A-4S

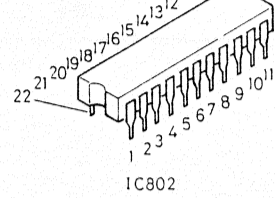

IC802

2SA733 2SC945 2SC1775A

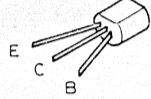
X801, X803, X804, X805
X806, X807, X808, X813
X814, X816, X817, X818

2SD571

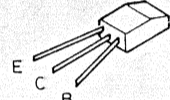
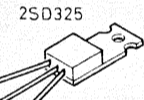
X802 X809 X810 X811
X812

X815

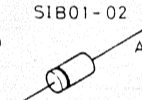
D810, D811, D812
D813

EE & EA (for Europe & Australia)

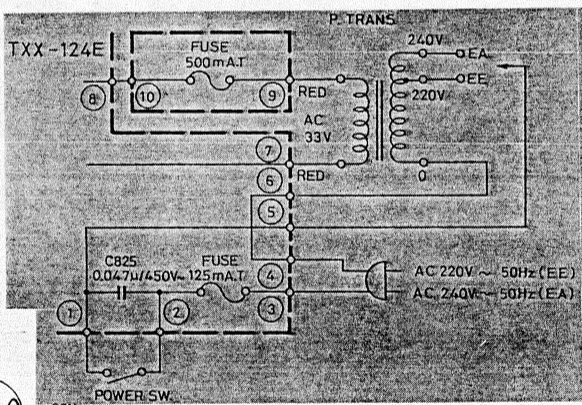

EP & EU (for Pacex & Other areas)

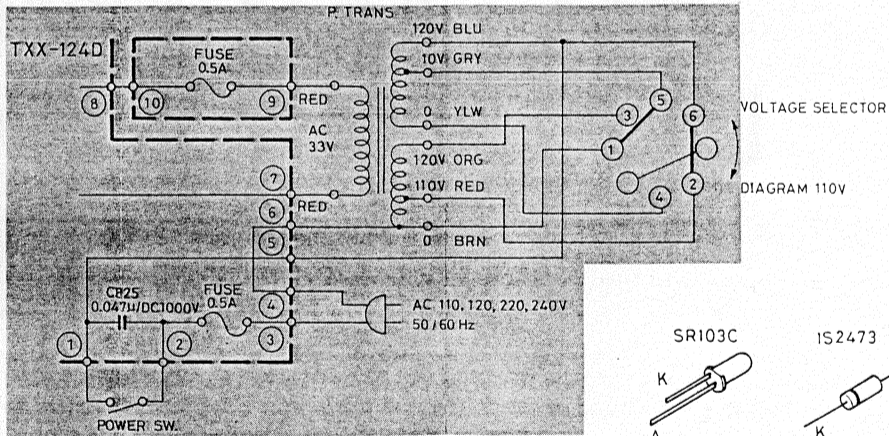

EBS (for England)

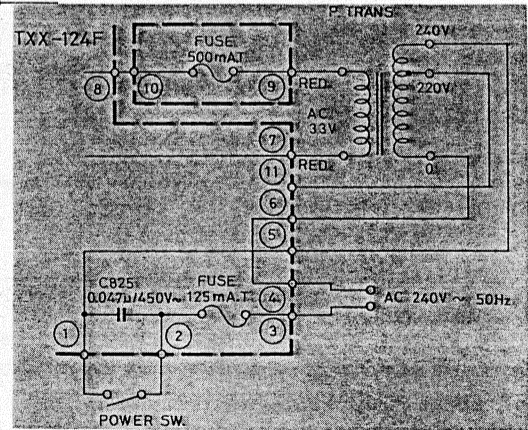

VOLT.	110V	120V	240V/220V
CONNECTION	1-5, 2-6	3-6, 4-1	3-4, 2-5

Warning !

- Be careful not to allow metallic dust, etc. to enter inside the unit, because its motor is comprised of magnetic elements.
- After replacement of the X813 transistor, apply KE45RTV (silicone adhesive) or an equivalent material around the transistor for thermal conduction.

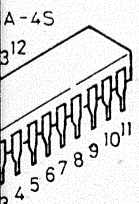
D**E****F**

NJM4558D, MJM4558D-D

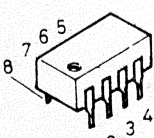

IC801, IC803

2SA733 2SC945 2SC1775A

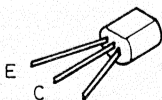
X801, X803, X804, X805
X806, X807, X808, X813
X814, X816, X817, X818

2SD571

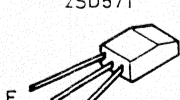
X802 X809 X810 X811
X812

2SD325

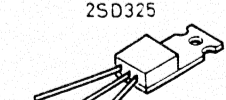

X815

SIB01-02

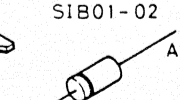
D810, D811, D812
D813

SR103C

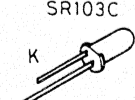
D804, D805, D806
D807, D808

IS2473

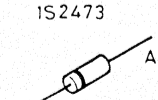

D801, D802, D803

TXX-124 Printed Circuit Board Ass'y

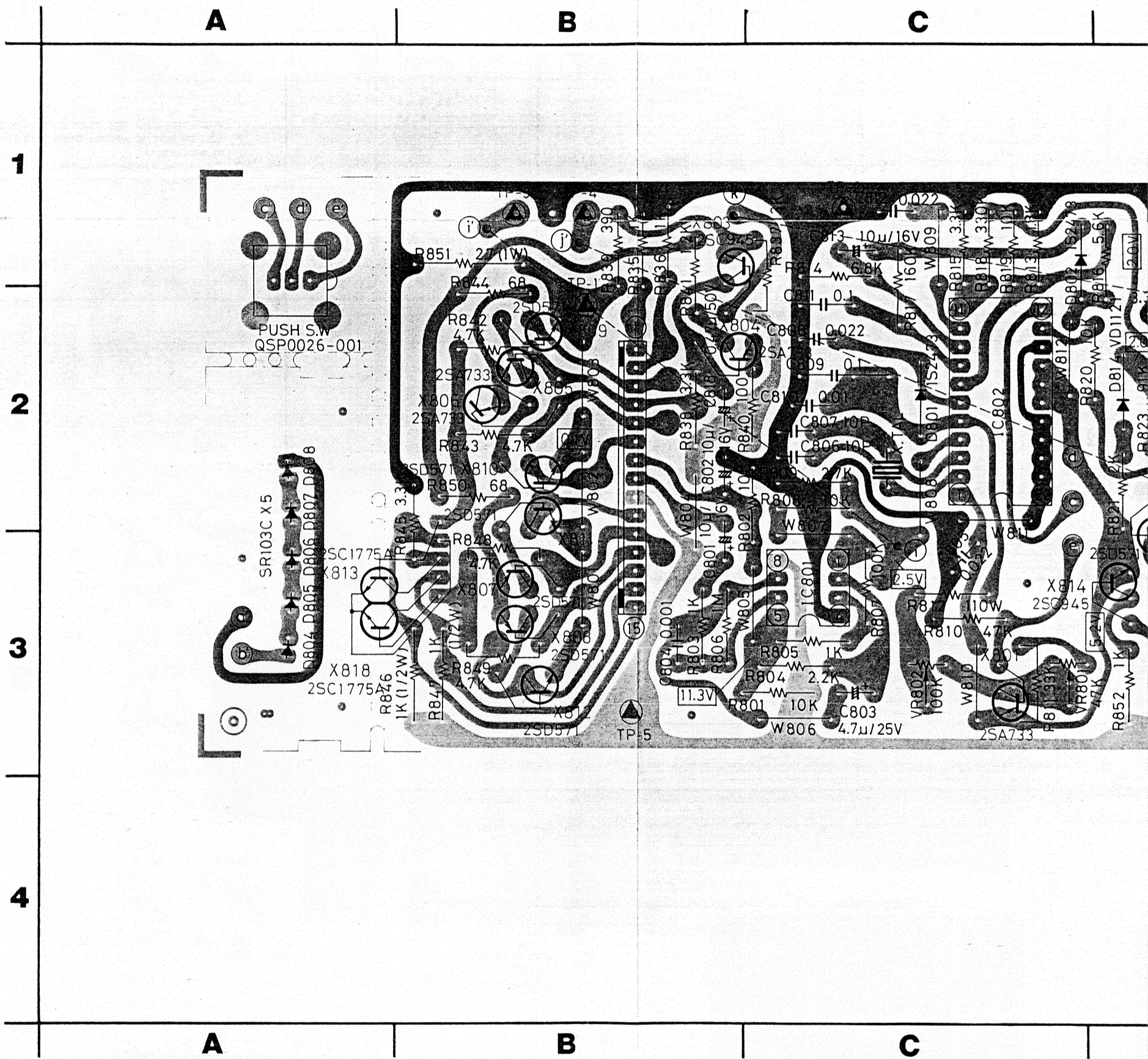

Notes:

1. Voltage values in are measured with a tester (impedance 33 kΩ/V) without a signal applied to the unit.
2. indicates positive B power supply.
 indicates ground.
 indicates the others.

Warning !

1. Be careful not to allow metallic dust, etc. to get inside the unit, because its motor is comprised of magnetic elements.
2. After replacement of the X813 transistor, apply KE45RTV (silicone adhesive) or an equivalent material around the transistor for thermal insulation.

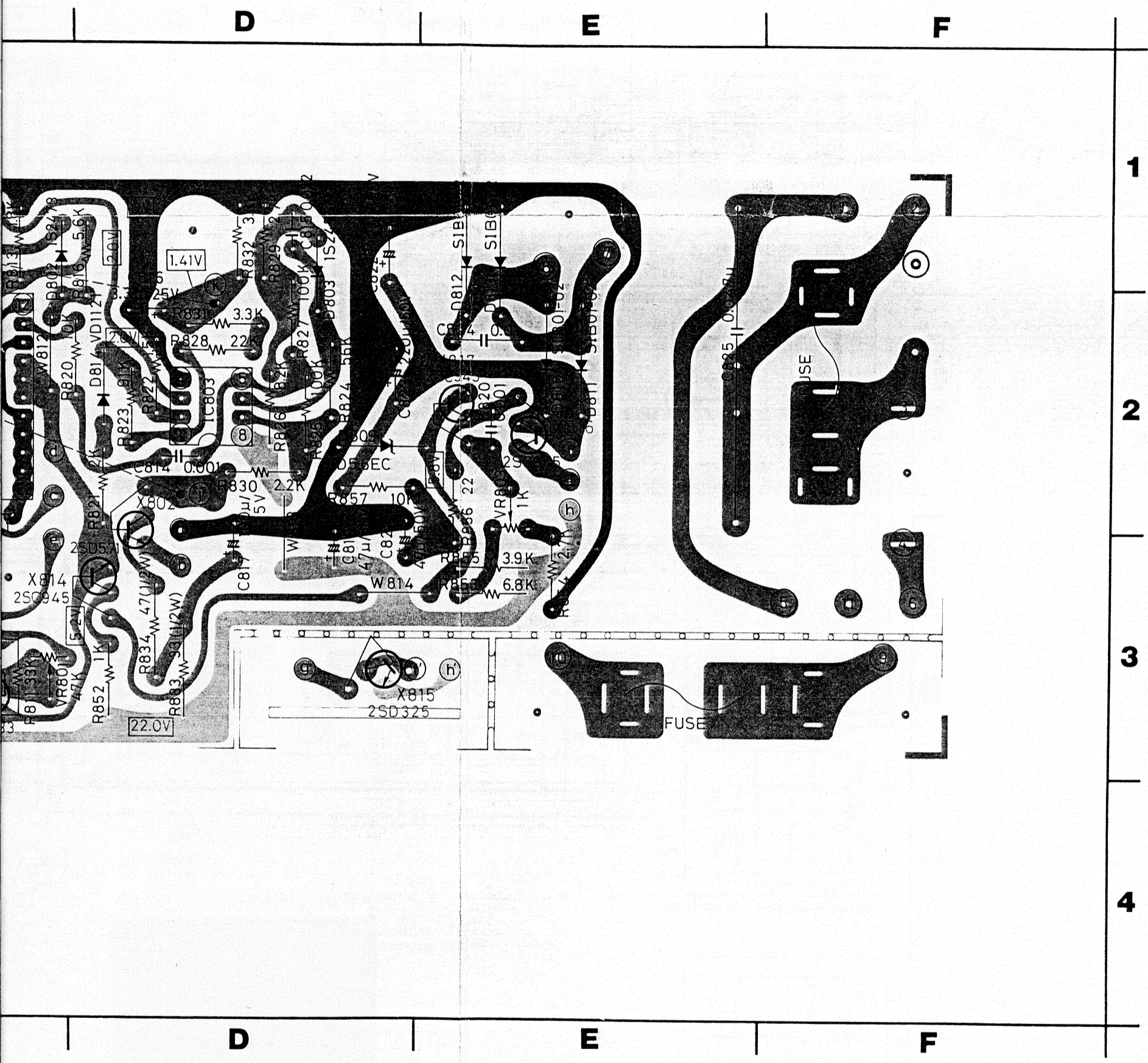

metallic dust, etc. to enter
 its motor is comprised of
 e X813 transistor, apply
 (resistive) or an equivalent
 nsistor for thermal con-