

ORDER INFORMATION

Material Type (1)	Rated Capacitance (2)	Cap. Tol. (3)	Rated Voltage (4)	T.C. (5)	Disc Size (6)	Lead Spacing (7)	Lead Style & Package (8)
----------------------	--------------------------	------------------	----------------------	-------------	------------------	---------------------	-----------------------------

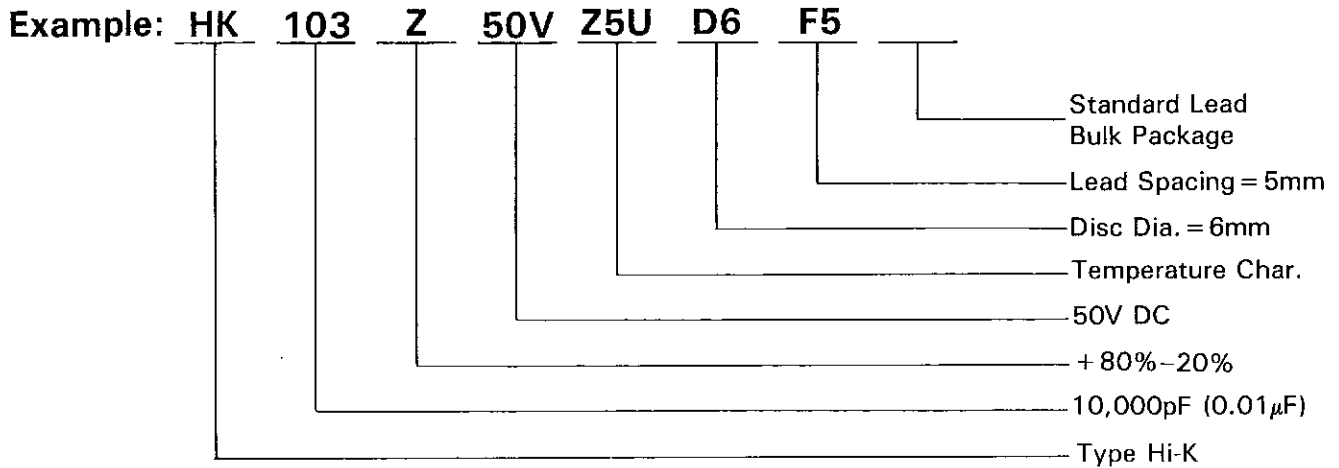

(1) Type: Material types

TC = T.C. Type (Class 1)
 HK = Hi-K Type (Class 2)
 SC = S.C. Type (Class 3)

(2) Rated Capacitance: in (pF)

The first two digits are significant figures of Capacitance and the third one denotes number of following zeros.

pF	0.47	1	4.7	10	100	1,000	10,000	100,000
Code No.	R47	010	4R7	100	101	102	103	104

Capacitance can also be indicated in the unit of Farads if code number is not to be used.

Ex. 1,000pF = 0.001µF = 1nF
 10,000pF = 0.01µF = 10nF
 100,000pF = 0.1µF = 100nF

(3) Capacitance Tolerance:

C = ± 0.25pF D = ± 0.5pF F = ± 1pF
 G = ± 2% J = ± 5% K = ± 10%
 M = ± 20% S = + 50%-20% P = + 100%-0
 Z = + 80%-20%

(4) Rated Voltage: in volts (V), DC

(5) T.C.: Temperature Characteristics

please refer to page CC-2 for the details

(6) Disc Size: Diameter (D) in mm.

(7) Lead Spacing: (F) in mm.

(8) Lead Style & Package:

The code number is omitted when the lead is style 1 (please see page CC-2) and the package is bulk.
 TBS = Straight Lead Ammo packaging
 TRS = Straight Lead Reel packaging
 TBF = Formed Lead Ammo packaging
 TRF = Formed Lead Reel packaging.

TYPE DESIGNATION

Materials Type:

T. C. TYPE (CLASS 1), Hi-K TYPE (CLASS 2), S. C. TYPE (CLASS 3) Ceramic Capacitors

Lead Style:

1. Complete Durez Coverage Leads
2. Exposed Disc Cut Leads (or Long Leads)
3. Inside Kink Cut Leads

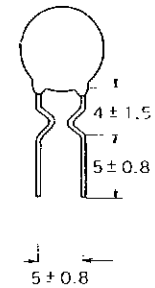
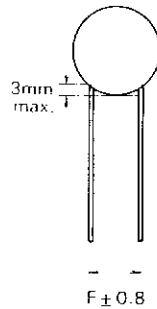
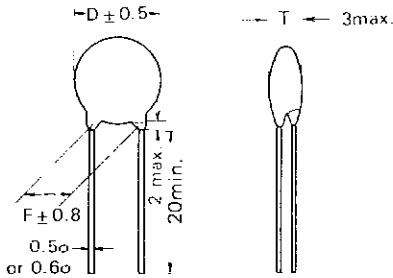

Unit: mm

Temperature characteristic of Capacitance:

T.C. TYPE (CLASS 1)

Table 1. Temperature Coefficient

Unit (ppm/°C)

T.C.	NPO	N150	N470	N750	SL	N1000
1 to 2.7pF	0 ± 250	-150 ± 250	-470 ± 250	-750 ± 250	+350 to -1000	-1000 ± 250
3 to 3.9pF	0 ± 120	-150 ± 120	-470 ± 120	-750 ± 120	+350 to -1000	-1000 ± 120
4pF and over	0 ± 60	-150 ± 60	-470 ± 60	-750 ± 120	+350 to -1000	-1000 ± 120

HI-K TYPE (CLASS 2)

Table 2. Temperature Characteristics

Item	Max. Capacitance Change from 25°C	Applicable Temperature Range	T.C.
K 3000	± 10%	-25 to +85°C	Y5P
K 7000	+22% ~ -33%	-25 to +85°C	Y5T
K10000	+22% ~ -56%	+10 to +85°C	Z5U
K13000	+22% ~ -82%	-25 to +85°C	Y5V
K16000	+22% ~ -82%	+10 to +85°C	Z5V

Table 3. Applicable Standards

Type	Materials	IEC Pub. 108	IEC Pub. 187	DIN 41920	EIA RS-198	Applications
T. C.	NPO N80 N150 N220 N330 N470 N750	Type 1B			C0 U1 P2 R2 S2 T2 U2	Temperature Compensating
	SL(P350-N1000)	Type 1D			U2M	General purpose
Hi-K	K3000 K7000 K10000 K13000 K16000		2B4 2D4 2E5 2F4 2F6	2P, 2R 2T 2U 2U -	Y5P Y5T Z5U Y5V Z5V	By-pass & Coupling

HI - K TYPE (CLASS 2)

The capacitors are used for coupling and decoupling, if low losses and high stability of capacitance are not of major importance.

SPECIFICATIONS:

1. Operating Temperature Range:

Class Y : $-25^{\circ}\text{C} \sim +85^{\circ}\text{C}$
 Class Z : $+10^{\circ}\text{C} \sim +85^{\circ}\text{C}$

2. Rated Working Voltage:

50V DC, 100V DC, 500V DC

3. Capacitance:

Measured at 25°C , 1KHz, 1 Vrms

4. Capacitance tolerance:

$\pm 10\%$ (K), $\pm 20\%$ (M), $+80\%-20\%$ (Z)

5. Insulation Resistance:

10,000 M Ω min. at working voltage, 60 sec.

6. Dissipation Factor (D.F.): at 25°C , 1KHz

2.5% max. (5.0% max. for Z5V)

7. Voltage Proof (Flash Test):

Withstand 2.5 times of rated working voltage, 1 sec.

8. Life Test:

2 times of rated voltage at 85°C for 500 hrs.

T.C. CHART: Temperature Dependency of Capacitance

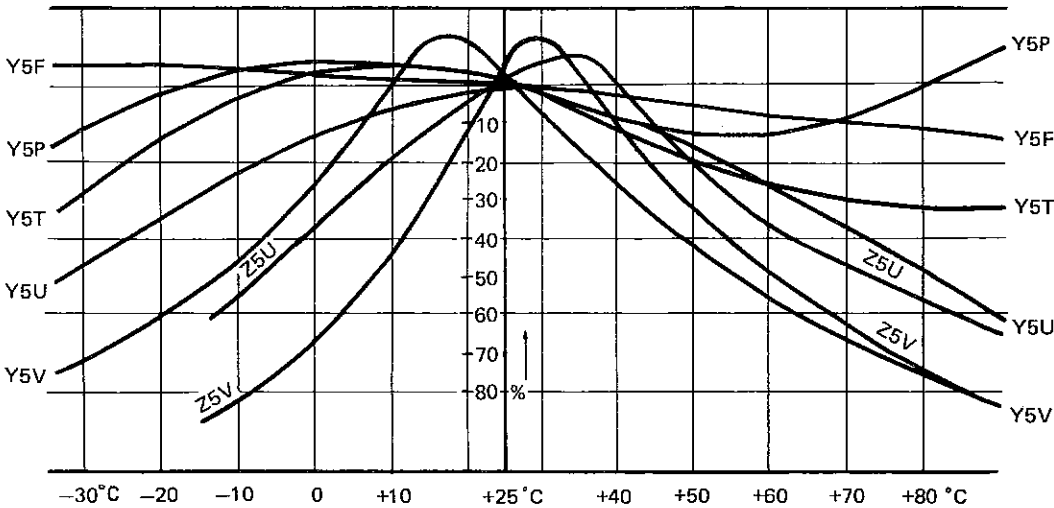

Capacitance Range Chart:

50WVDC & 100WVDC

DIMENSION (mm)		TEMPERATURE CHARACTERISTIC (Capacitance in pF)				
D	F	10V	25V	50V	100V	250V
5.0	2.5	100-1200	100-2000	1000-3300	1000-5600	1000-10000
6.0	5.0	1500-2200	2200-2700	4700-5600	6800-10000	10000-20000
8.0	5.0 (6.35)	2700-3900	3300-4700	6800-10000	10000-15000	20000-22000
10.0	5.0 (6.35)	4700-6800	5600-10000	15000	20000-22000	30000-50000
12.0	5.0 (6.35)	10000		20000-22000	30000-33000	68000-82000
14.0	(6.35) 10.0				47000-50000	100000

500WVDC

DIMENSION (mm)		TEMPERATURE CHARACTERISTIC (Capacitance in pF)				
D	F	10V	25V	50V	100V	250V
5.0	2.5	100-560	100-680	100-1200	1000-2200	1000-3300
6.0	5.0	680-820	820-1200	1500-2200	2700-3300	3900-4700
8.0	5.0 (6.35)	1000-1800	1500-2500	2700-3900	3900-6800	5000-8200
10.0	5.0 (6.35)	2000-3000	2700-3900	4700-6800	8200-10000	10000-15000
12.0	5.0 (6.35)	3300-4700	4000-5600	8200-10000	20000	20000

TAPING SPECIFICATIONS:

These radial taped ceramic disc capacitors are designed especially for automatic insertion. The available types for radial taped disc are diameters ϕ 11.0 mm and under.

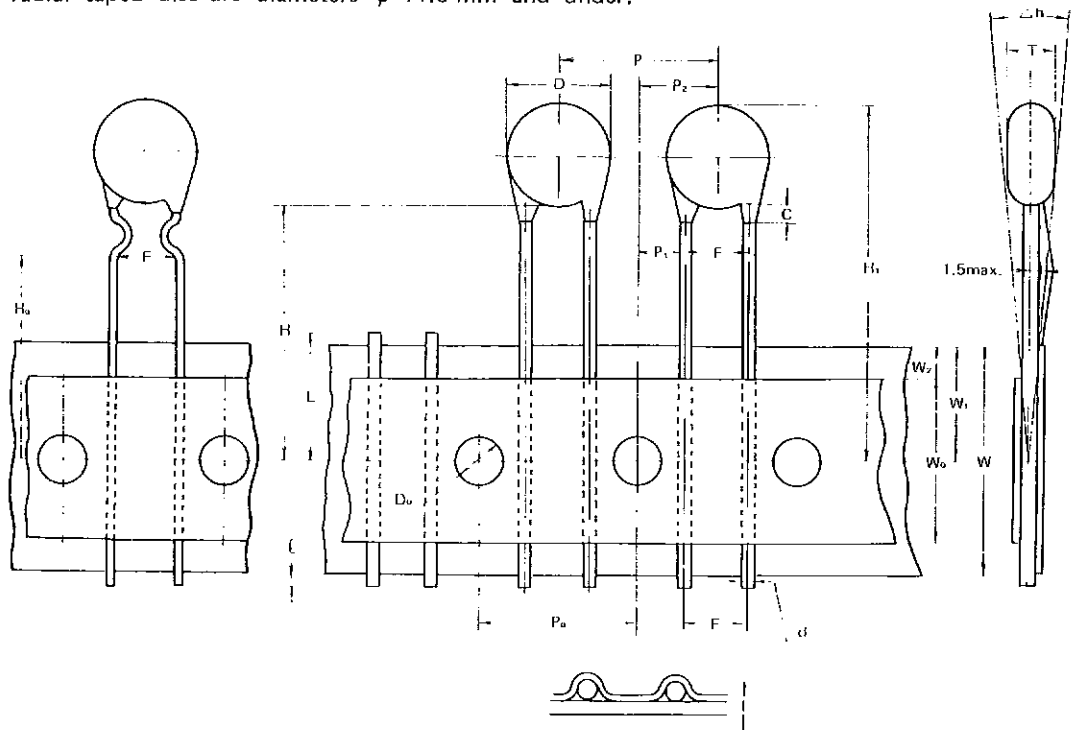

Unit: mm

Item	Symbol	Specification		Remarks
		Value	Tolerance	
Body diameter	D	11.0	max.	
Body thickness	T	3.5	max.	
Lead-wire diameter	d	0.6	+0.06 - 0.05	
Pitch of component	P	12.7	±1.0	
Feed hole pitch	P ₀	12.7	±0.3	Cumulative pitch error: 1.0mm/20 pitch
Feed hole center to lead	P ₁	3.85	±0.7	To be measured at bottom of clinch
Hole center to component center	P ₂	6.35	±1.3	
Lead-to-lead distance	F	5.0	±0.8	
Component alignment, F-R	Δh	0	±2.0	
Tape width	W	18.0	+1.0 - 0.5	
Hold-down tape width	W ₀	11.0	min.	
Hole position	W ₁	9.0	+0.75 - 0.5	
Hold-down tape position	W ₂	3.0	max.	
Height of component from tape center	For Straight Lead Type	H	20.0	+1.0 - 0.5
	For Kinked Lead Type	H ₀	16.0	±0.5
Component height	H ₁	32.25	max.	
Lead-wire protrusion	l	2.0	max.	
Feed hole diameter	D ₀	4.0	±0.3	
Total tape thickness	t	0.7	±0.2	Ground paper: 0.5 ± 0.1 mm
Length of snapped lead	L	11.0	max.	
Coating rundown on leads	C	1.5	max.	

Anchor with a stapler when the tape is cut or completed. It is accepted that up to three parts may become detached from the tape.

REEL PACKAGE

(2,000 or 2,500 Capacitors per Reel)

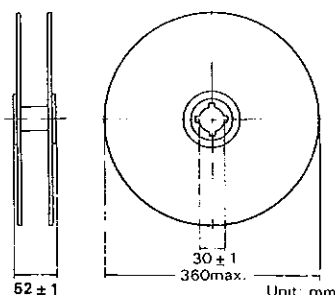

BOX PACKAGE

(2,000 Capacitors per Box)

