

TMC4671_EVAL_V1.0

[1]_InterfaceConnectors
[1]_InterfaceConnectors.SchDoc



[2]_Communication_Inputs
[2]_Communication_Inputs.SchDoc



[3]_Output_Feedback
[3]_Output_Feedback.SchDoc



[4]_Output_Feedback_2
[4]_Output_Feedback_2.SchDoc



[5]_Analog_input_filters
[5]_Analog_input_filters.SchDoc



[6]_PSU
[6]_PSU.SchDoc



ChangeLog
ChangeLog.SchDoc



Title: TMC4671_EVAL_V1.0		
Size: A4	Project: TMC4671-EVAL	Version: 1.2
Date: 9/6/2019	Time: 10:56:35 AM Sheet 0 of 8	
File: TMC4671-EVAL_V1_2.SchDoc		



Interface connectors, mounting holes & testpads

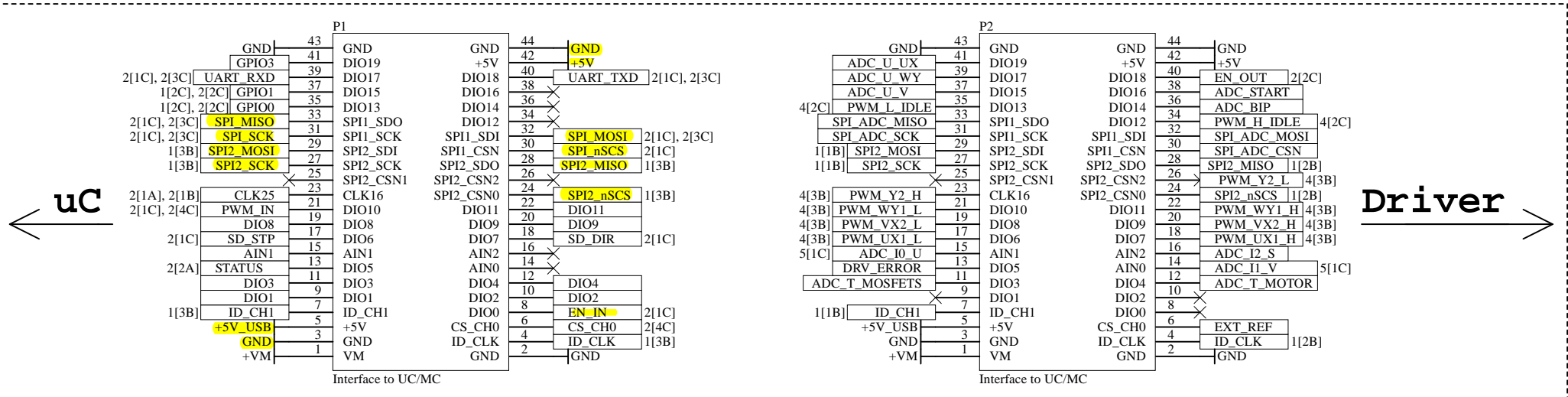

▲ Testpoints for functional testing. Please apply all generated supply voltages and relevant signals.

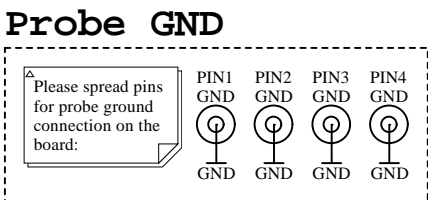
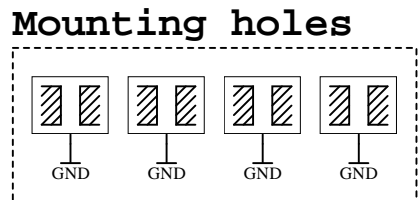
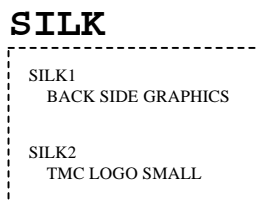
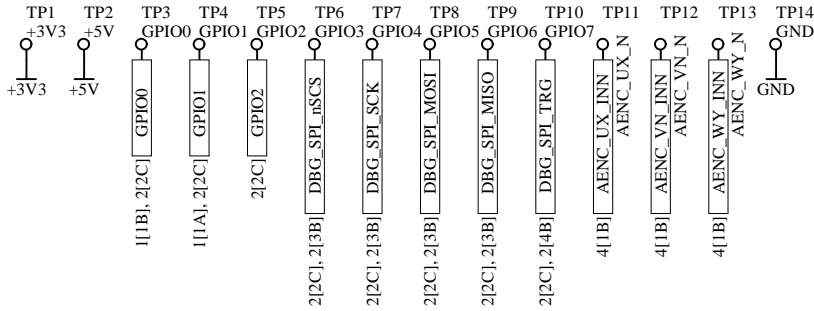

TMC4671-EVAL

Title: Interface connectors, mounting holes & testpads		
Size: A4	Project: TMC4671-EVAL	Version: 1.2
Date: 9/6/2019	Time: 10:56:35 AM Sheet 1 of 8	
File: [1]_InterfaceConnectors.SchDoc		



Communication & Inputs

Clock & Misc

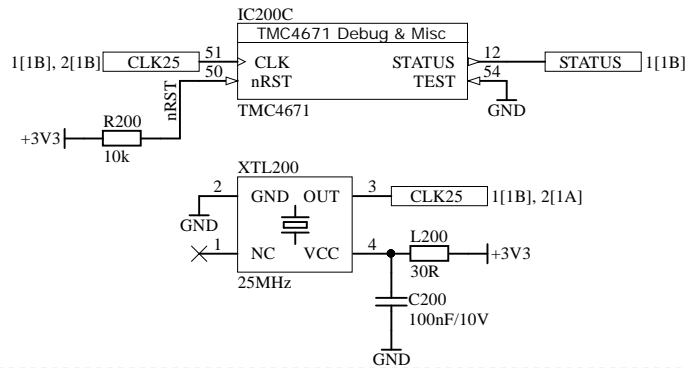

TMC4671 I/O

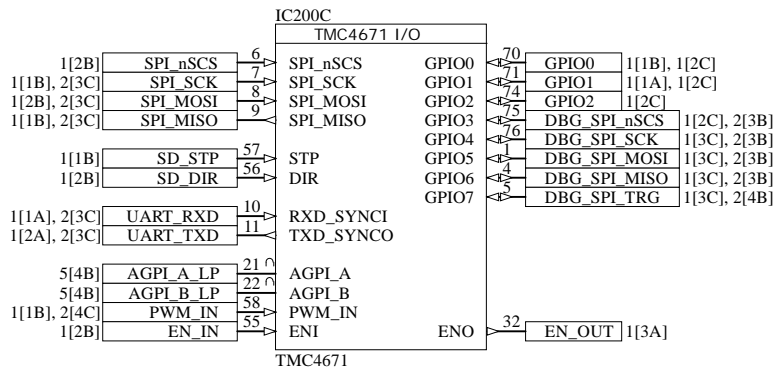

TMC Realtime Monitoring Interface

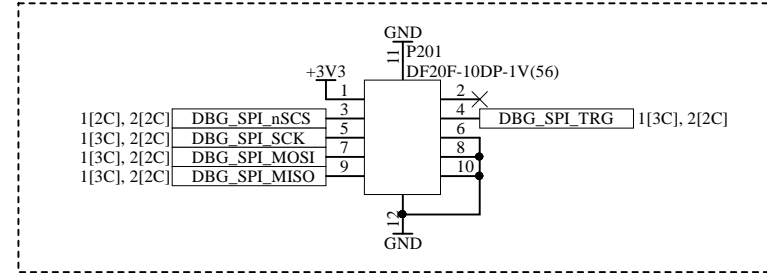

Module identification EEPROM

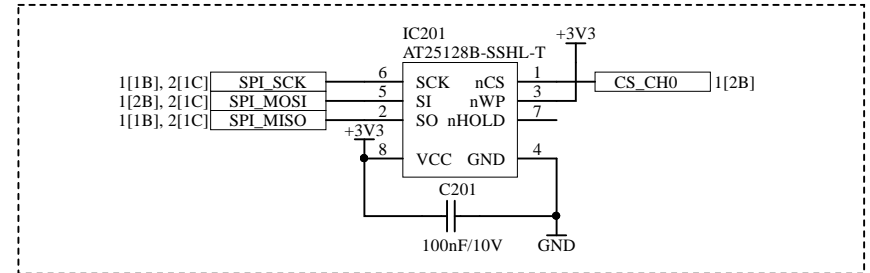

UART / Sync I/O

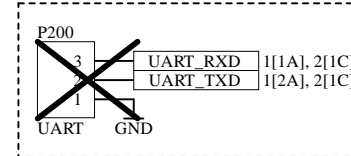

PWM Input

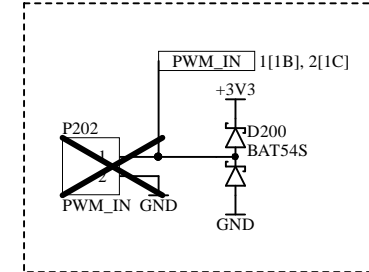

Title:	Communication & Inputs	
Size:	Project: TMC4671-EVAL	Version: 1.2
A4	Date: 9/6/2019	Time: 10:56:36 AM Sheet 2 of 8
Date:	File: [2]_Communication_Inputs.SchDoc	



Output & Feedback

ABN Encoder 1

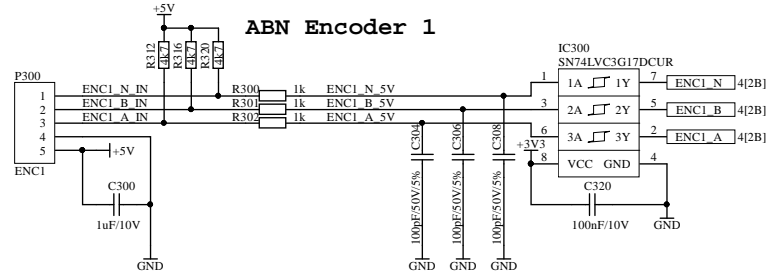

ABN Encoder 2

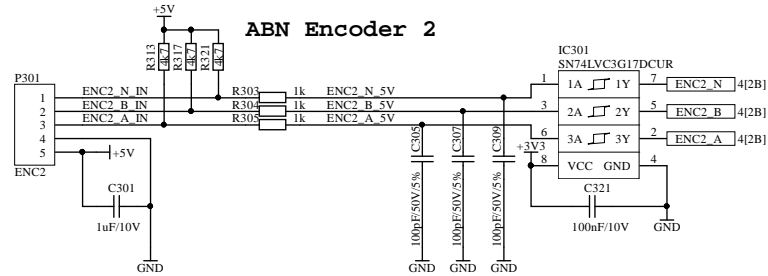

Hall sensor input

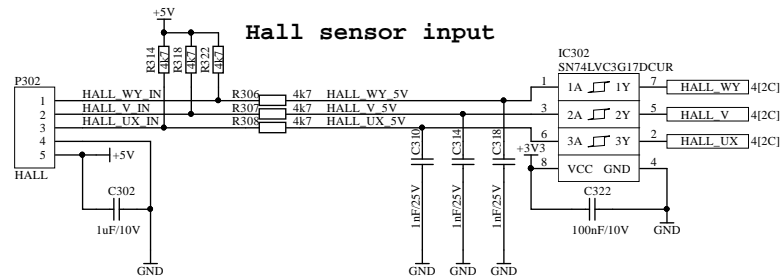

Reference switches

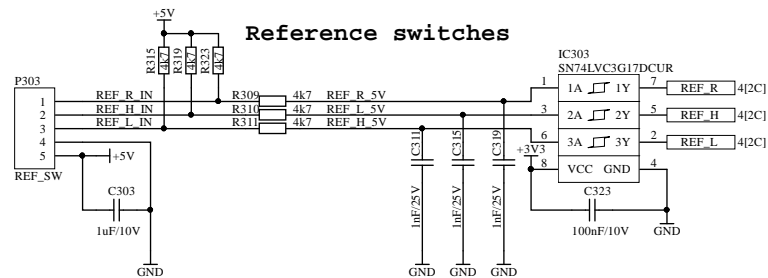

Title: Output & Feedback

Size: A4 Project: TMC4671-EVAL Version: 1.2

Date: 9/6/2019 Time: 10:56:37 AM Sheet 3 of 8

File: 13_Output_Feedback_SchDoc



Output & Feedback 2

TMC4671 Sensing & Output

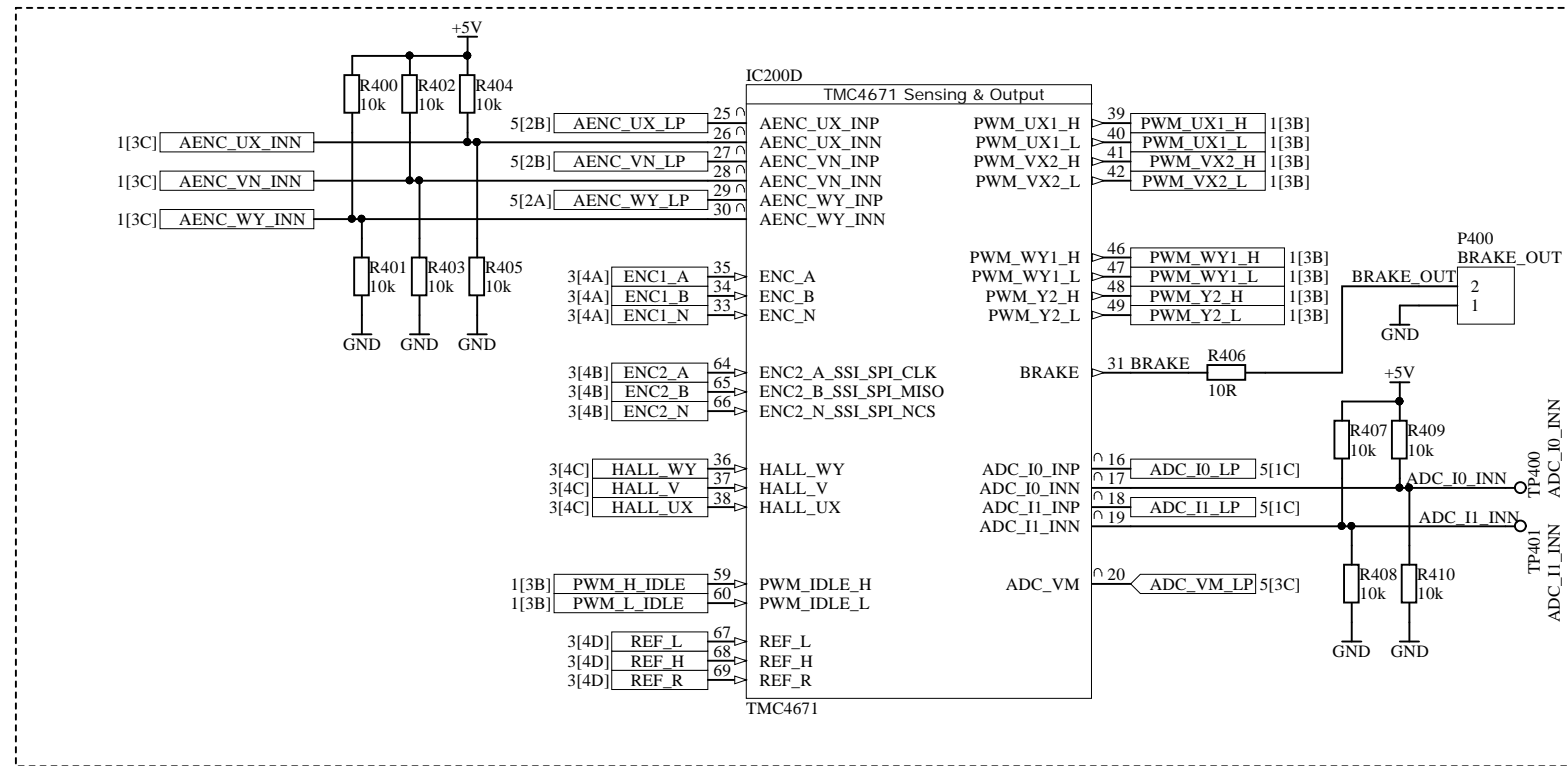

Title: Output & Feedback 2			
Size: A4	Project: TMC4671-EVAL		Version: 1.2
Date: 9/6/2019	Time: 10:56:38 AM		Sheet 4 of 8
File: [4]_Output_Feedback_2.SchDoc			

Analog inputs & filters

Analog encoder input + filters

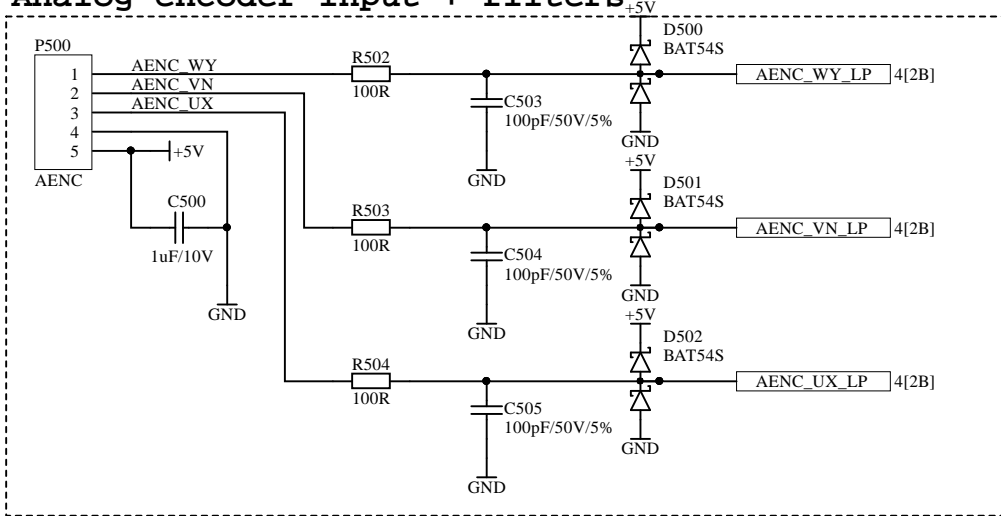

Analog inputs A & B with filters

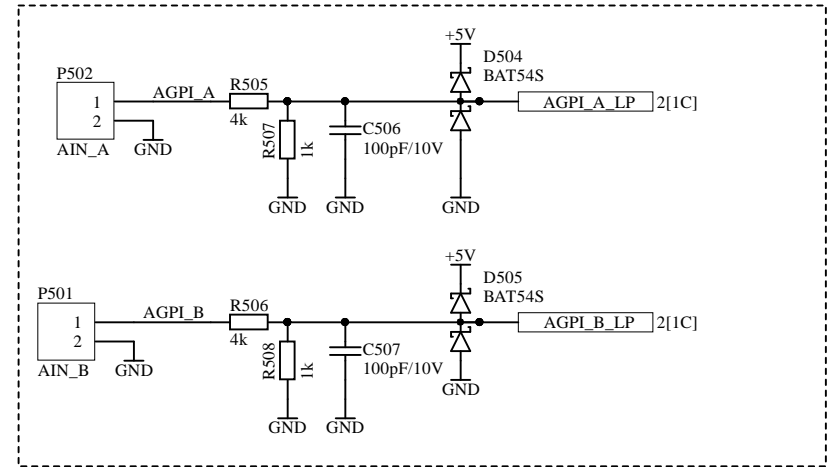

ADC Filter

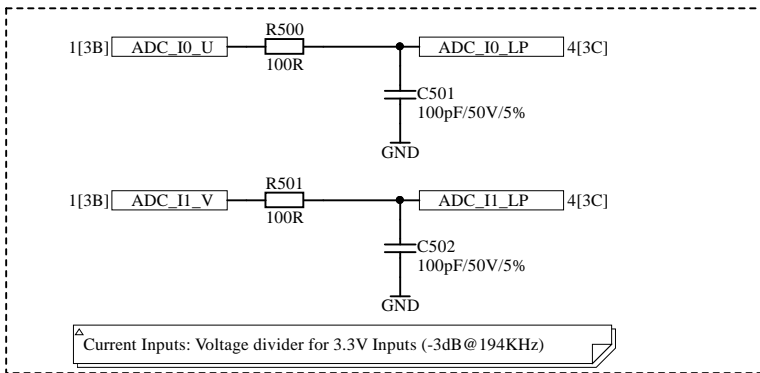

VM ADC Filter

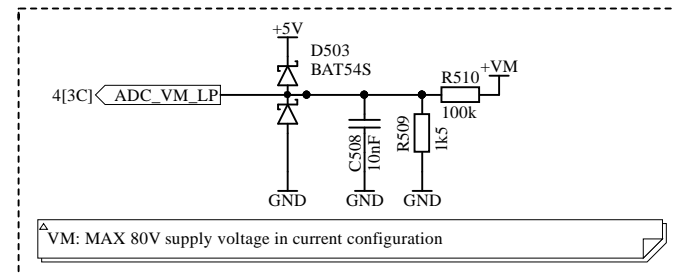

Title: Analog inputs & filters			
Size: A4	Project: TMC4671-EVAL		Version: 1.2
Date: 9/6/2019	Time: 10:56:38 AM		Sheet 5 of 8
File: [5]_Analog_input_filters.SchDoc			

PSU

+3V3 LDO

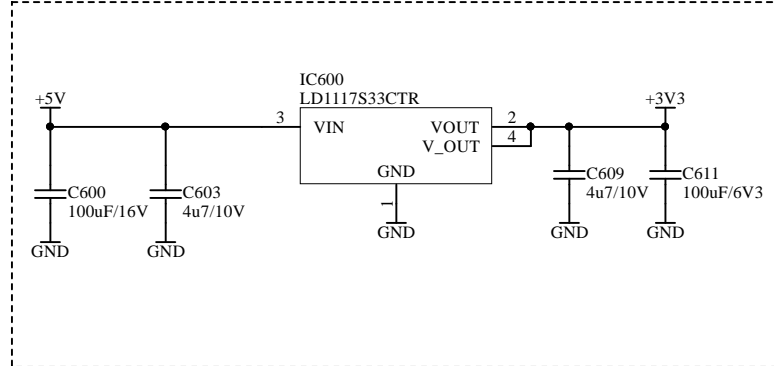

TMC power

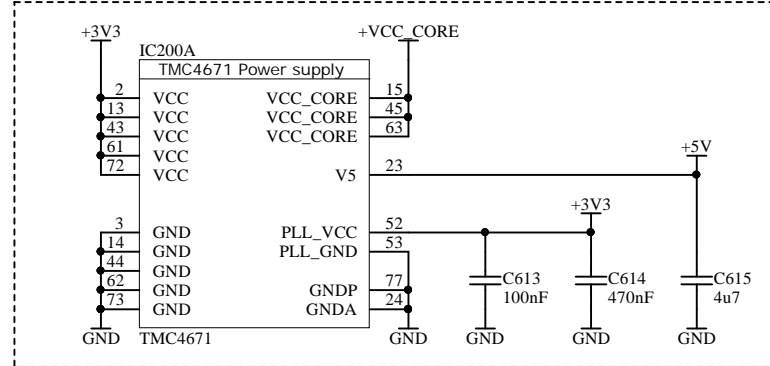

Bypass capacitors

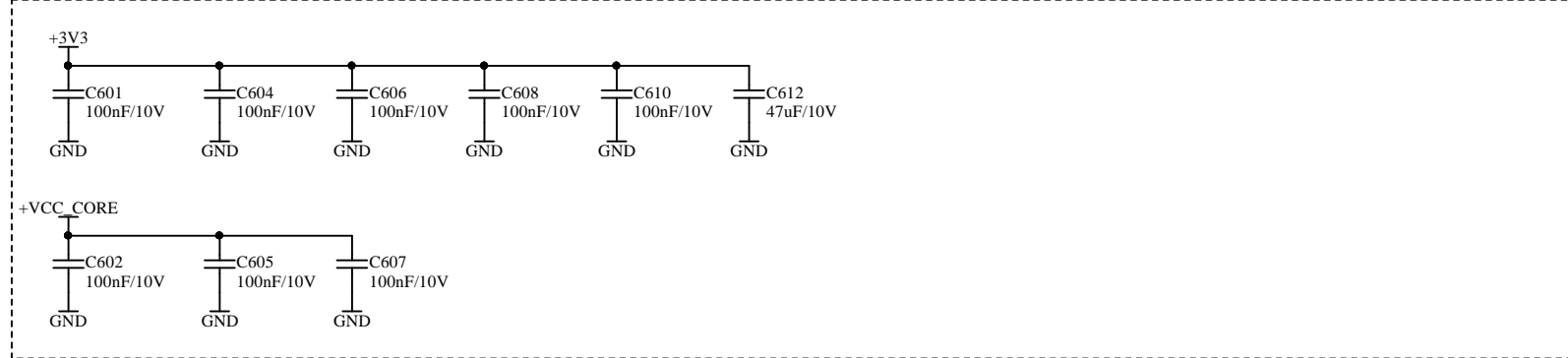

Title:	PSU	
Size:	Project: TMC4671-EVAL	Version: 1.2
A4		
Date:	9/6/2019	Time: 10:56:39 AM Sheet 6 of 8
File:	[6]_PSU.SchDoc	



ChangeLog

V1.0 - Initial design

25.09.2017

- Fixed XTL200 FOX924B pinout bug (swapped pins 3 & 4).

V1.1 - Bug fixes

04.12.2017

- Fixed twisted AENC_UX and AENC_WY nets.
- Changed P200 pin order on PCB to [+5V, GND, AENC_UX, AENC_VN, AENC_WY].
- Minor clean-ups.

22.12.2017

- Reduced TMC4671 footprint pad widths by 0.7mil.
- Increased TMC4671 pad clearances from 6mil to match pad spacing 8.5mil.

V1.2 - Bug fixes

03.09.2019

- Removed SRV05-4 protection ICs.
- Moved all 4k7 pull-ups next to pinheaders on page 4.
- Changed encoder filter values to 1k/100pF.
- Changed hall sensor and reference input filter values to 4k7/1nF.

Title:	ChangeLog	
Size:	Project: TMC4671-EVAL	Version: 1.2
A4		
Date:	9/6/2019	Time: 10:56:39 AM Sheet 7 of 8
File:	ChangeLog.SchDoc	

