

# Solid State Relays PCB, 1-Phase ZS/IO Type RP 130 ...-.-., RP 132 ...-.-.



- AC Solid State Relay for PCB mounting
- Zero or instant-on switching
- Rated operational current: 2 and 4 AAC
- Non-repetitive voltage: Up to 850 Vp
- Rated operational voltage range: Up to 400 VACrms
- Input range: 3 to 32 VDC
- Insulation: OPTO (input-output) 4000 VACrms

## Product Description

The zero switching relay for PCB mounting is used for a wide range of applications with either resistive or inductive loads. The zero switching relay switches on when the AC sine curve just crosses the zero value, and the relay switches

off when the current crosses zero. The instant-on switching relay switches on immediately when the control voltage is applied. The relay switches off when the current crosses the zero value.

## Ordering Key

**RP 130 240-4-0**

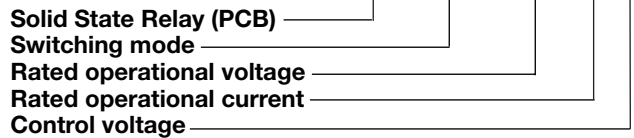

## Type Selection

Switching mode	Rated operational voltage	Rated operational current	Control voltage
130: Zero switching	240: 230 VACrms	2: 2 AACrms	0: 3 to 32 VDC
132: Instant-on switching	440: 400 VACrms	4: 4 AACrms	

## Selection Guide

Rated operational voltage	Control voltage	Rated operational current 2 AACrms	4 AACrms
230 VACrms	3 to 32 VDC	RP 130 240-2-0* RP 132 240-2-0**	RP 130 240-4-0* RP 132 240-4-0**
400 VACrms	3 to 32 VDC	RP 130 440-2-0* RP 132 440-2-0**	RP 130 440-4-0* RP 132 440-4-0**

\* Zero switching  
\*\* Instant-on switching

## General Specifications

	RP 13. 240-.-0	RP 13. 440-.-0
Operational voltage range	24 to 280 VACrms	48 to 480 VACrms
Non-rep. peak voltage	≥ 650 V <sub>p</sub>	≥ 850 V <sub>p</sub>
Zero voltage turn-on	≤ 20 V	≤ 40 V
Operational frequency range	45 to 65 Hz	45 to 65 Hz
Power factor	≥ 0.5 @ 230 VACrms	≥ 0.5 @ 400 VACrms
Approvals	UL, CSA, VDE	UL, CSA, VDE
CE-marking	Yes	Yes



## Input Specifications

	RP 130 .40-.0	RP 132 .40-.0
Control voltage range	3 to 32 VDC	3 to 32 VDC
Pick-up voltage	≤ 3 VDC	≤ 3 VDC
Drop-out voltage	≥ 1 VDC	≥ 1 VDC
Reverse voltage	≤ 6 VDC	≤ 6 VDC
Response time pick-up	≤ 1/2 cycle	≤ 1 ms
Response time drop-out	≤ 1/2 cycle	≤ 1/2 cycle
Input impedance	1.5 kΩ	1.5 kΩ

## Output Specifications

	RP 13. .40-2-0	RP 13. .40-4-0
Rated operational current AC 1 AC 3	2 Arms 2 Arms	4 Arms 3 Arms
Minimum operational current	20 mArms	20 mArms
Rep. overload current t=1 s	≤ 6 A <sub>p</sub>	≤ 12 A <sub>p</sub>
Non-rep. surge current t=20 ms	42 A <sub>p</sub>	90 A <sub>p</sub>
Off-state leakage current @ rated voltage and frequency	≤ 5 mArms	≤ 5 mArms
I <sup>2</sup> t for fusing t=1-10 ms	≤ 9 A <sup>2</sup> s	≤ 40 A <sup>2</sup> s
Critical di/dt	≥ 10 A/μs	≥ 10 A/μs
On-state voltage drop @ rated current	≤ 1.6 Vrms	≤ 1.6 Vrms
Critical dV/dt commutating	≥ 4 V/μs	≥ 4 V/μs
Critical dV/dt off-state	≥ 100 V/μs	≥ 100 V/μs

## Thermal Specifications

	RP 13. .40-2-0	RP 13. .40-4-0
Operating temperature	-20° to +70°C (-4° to +158°F)	-20° to +70°C (-4° to +158°F)
Storage temperature	-40° to +100°C (-40° to +212°F)	-40° to +100°C (-40° to +212°F)
Junction temperature	≤ 125°C (≤ 257°F)	≤ 125°C (≤ 257°F)
R <sub>th</sub> junction to case	≤ 20.5 K/W	≤ 15.6 K/W
R <sub>th</sub> junction to ambient	≤ 37.5 K/W	≤ 22.5 K/W

## Insulation Input-Output

Rated insulation voltage	≥ 4000 VACrms
Insulation resistance	≥ 10 <sup>10</sup> Ω
Insulation capacitance	≤ 8 pF
Reference voltage according to VDE 01 10 B Insulation group C	500 VACrms, 600 VDC

## Housing Specifications

Weight	Approx. 10 g
Housing material	Noryl GFN 1, black
Terminals	Copper, tin-plated
Potting compound	Flame retardant polyurethane

## Applications

These relays can be used to switch heaters, motors, lights, valves or solenoids. When used at full load current, the relays must be placed

vertically. If more than one relay is mounted, please allow a minimum distance of 20 mm in between for sufficient air cooling.

## Accessories

Fuses and varistors:  
For further information refer to "General Accessories".

### Wiring Diagram

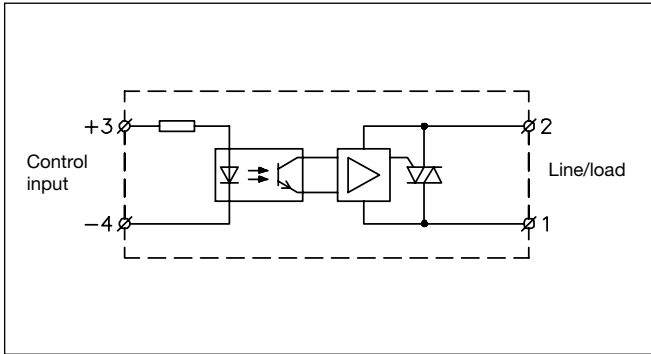

### Derating Curve

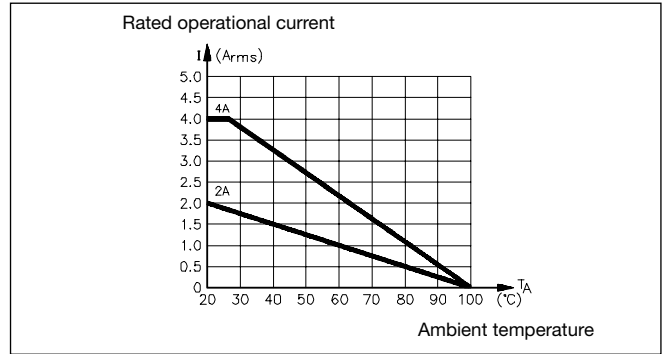

### Functional Diagrams

RP 130 .40-.-0

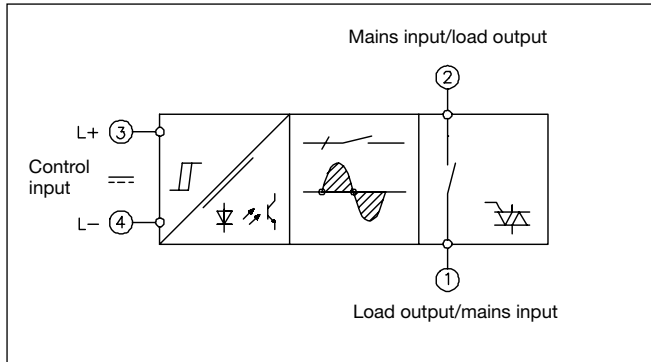

RP 132 .40-.-0

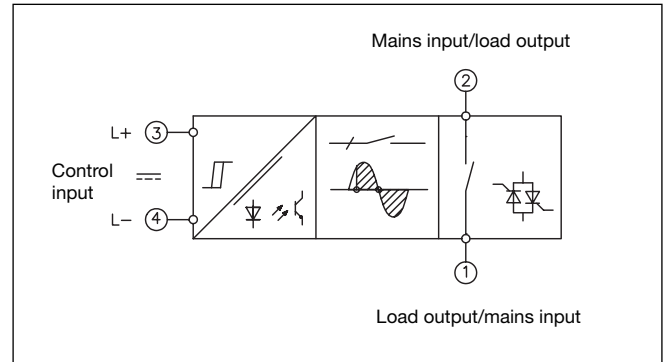

### Dimensions

