

500mA LiFePO4 Battery Charger CN3058

General Description:

The CN3058 is a complete constant-current /constant voltage linear charger for single cell LiFePO4 rechargeable batteries. The device contains an on-chip power MOSFET and eliminates the need for the external sense resistor and blocking diode. Its low external component count makes CN3058 ideally suited for portable applications.

Thermal feedback regulates the charge current to limit the die temperature during high power operation or high ambient temperature. The regulation voltage is internally fixed at 3.6V with 1.5% accuracy, it can also be adjusted with an external resistor. The charge current can be programmed externally with a single resistor. When the input supply (wall adapter or USB supply) is removed, the CN3058 automatically enters a low power sleep mode , dropping the battery drain current to less than 3uA. Other features include undervoltage lockout, automatic recharge, battery temperature sensing and charging/termination indicator.

The CN3058 is available in 8-pin SOP package.

Applications:

- Miner's lamp
- LiFePO4 battery applications
- Lead-acid batteries
- A variety of chargers

Features:

- Complete Charge Management for Single Cell LiFePO4 Battery
- Input voltage range from 3.8V to 6V
- On-chip Power MOSFET
- No external Blocking Diode or Current Sense Resistors Required
- Preset 3.6V Regulation Voltage with 1.5% Accuracy, adjustable with an external resistor
- Precharge Conditioning for Reviving Deeply Discharged Cells and Minimizing Heat Dissipation During Initial Stage of Charge
- Programmable Continuous Charge Current Up to 500mA
- Constant-Current/Constant-Voltage/Constant-Temperature Operation with Thermal Regulation to Maximize Charge Rate Without Risk of Overheating
- Automatic Low-Power Sleep Mode When Input Supply Voltage is Removed
- Status Indication for LEDs or uP Interface
- C/10 Charge Termination
- Automatic Recharge
- Battery Temperature Sensing
- Available in SOP8 Package
- Pb-free, rohs compliant and Halogen free

Pin Assignment

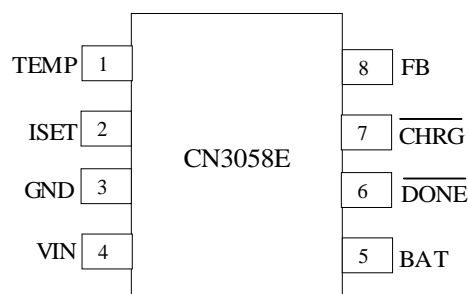

CONSONANCE

Typical Application Circuit

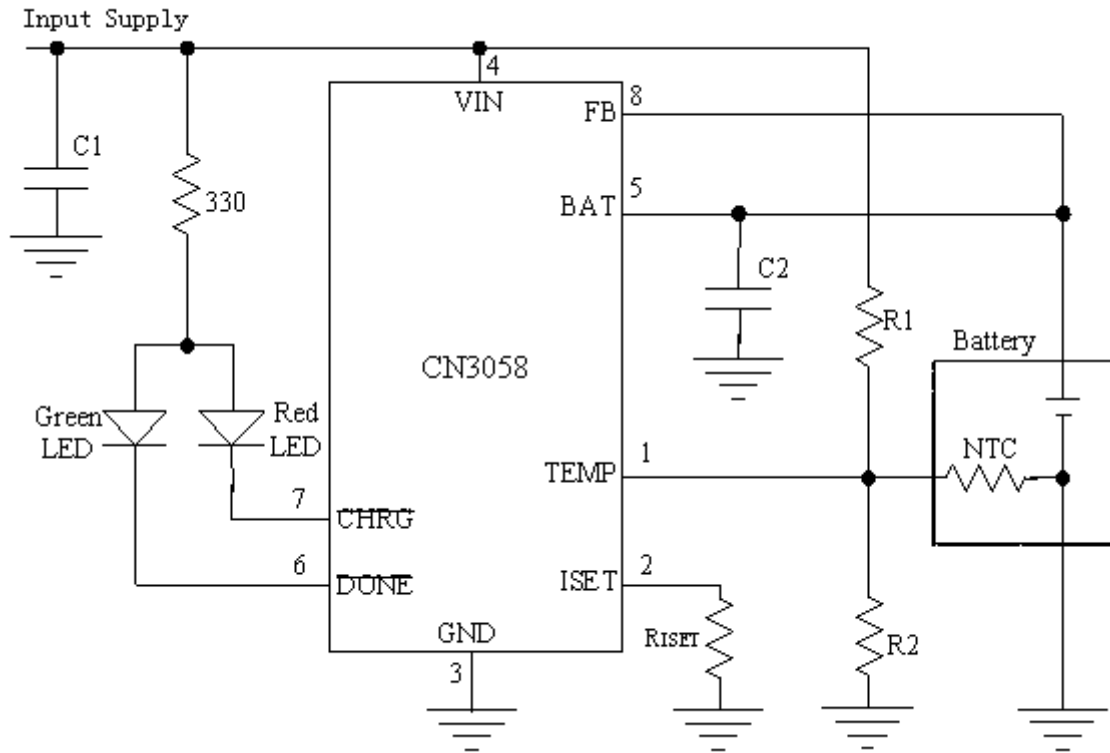

Figure 1 Typical Application Circuit(Constant Voltage Level 3.6V)

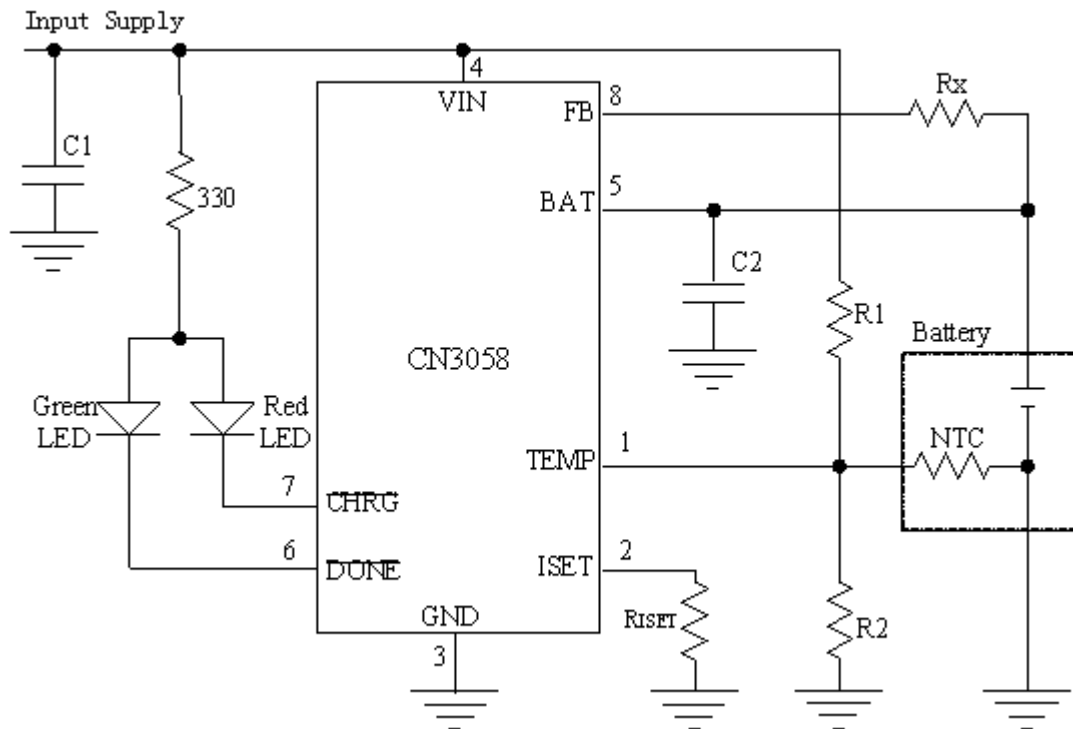

Figure 2 Application Circuit(Adjust Constant Voltage Level with Rx)

CONSONANCE

In Figure 2, the BAT pin's voltage in constant voltage mode is given by the following equation:

$$V_{bat} = 3.6 + 3.61 \times 10^{-6} \times R_x$$

Where, V_{bat} 's is in volt

R_x 's is in ohm

Block Diagram

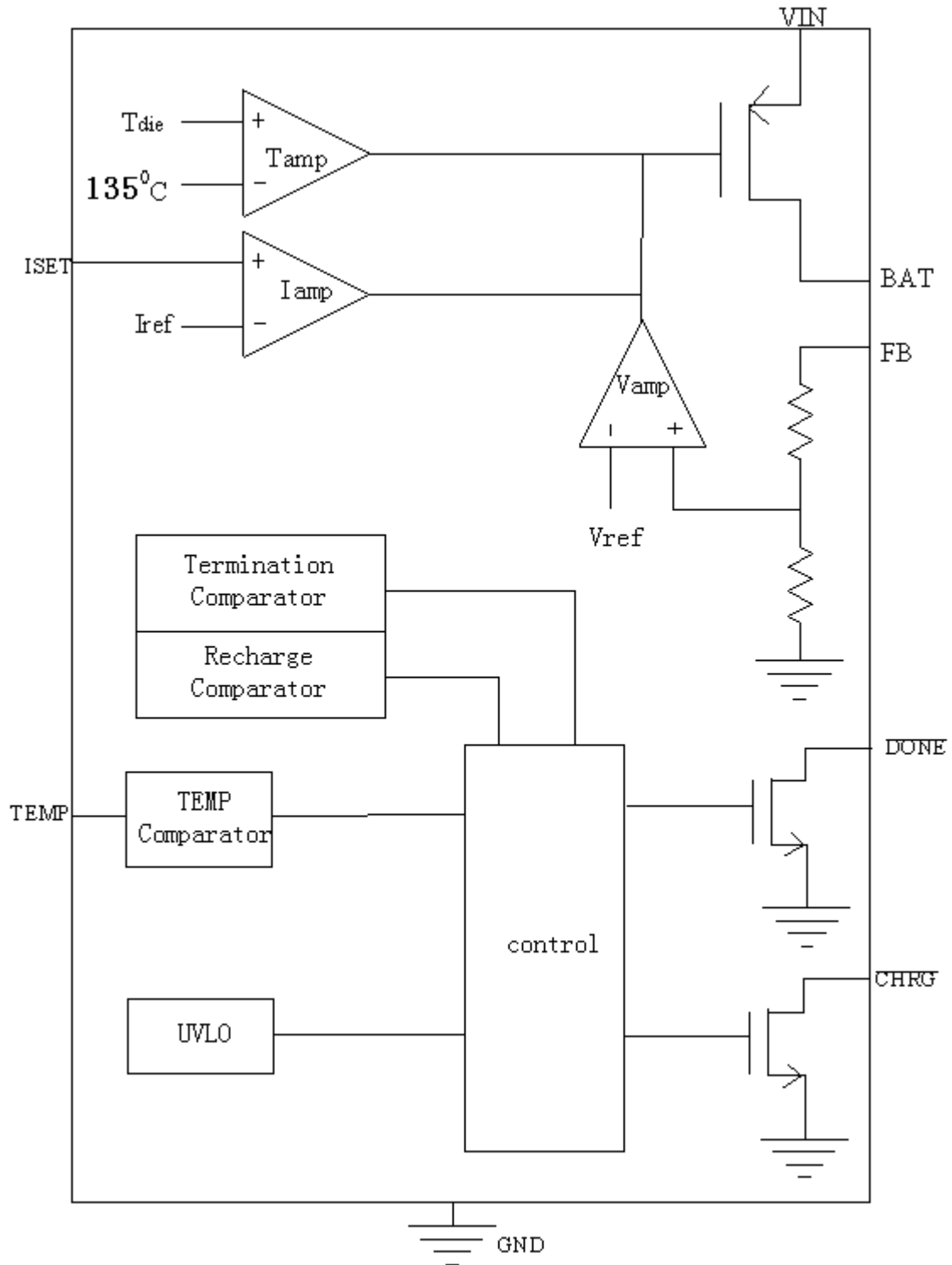

Figure 3 Block Diagram

CONSONANCE

Pin Description

Pin No.	Name	Function Description
1	TEMP	Temperature Sense Input. Connecting TEMP pin to NTC thermistor's output in battery pack. If TEMP pin's voltage is below 45% or above 80% of supply voltage VIN, this means that battery's temperature is too high or too low, charging is suspended. If TEMP's voltage level is between 45% and 80% of supply voltage, battery fault state is released, and charging will resume. The temperature sense function can be disabled by grounding the TEMP pin.
2	ISET	Constant Charge Current Setting and Charge Current Monitor Pin. The charge current is set by connecting a resistor R _{ISET} from this pin to GND. When in precharge mode, the ISET pin's voltage is regulated to 0.12V. When in constant charge current mode, the ISET pin's voltage is regulated to 1.205V. In all modes during charging, the voltage on ISET pin can be used to measure the charge current as follows: $I_{CH} = (V_{ISET} / R_{ISET}) \times 1011$
3	GND	Ground Terminal.
4	VIN	Positive Input Supply Voltage. VIN is the power supply to the internal circuit. When VIN drops to within 10mv of the BAT pin voltage, CN3058 enters low power sleep mode, dropping BAT pin's current to less than 3uA.
5	BAT	Battery Connection Pin. Connect the positive terminal of the battery to BAT pin. BAT pin draws less than 3uA current in chip disable mode or in sleep mode. BAT pin provides charge current to the battery and provides constant charging voltage.
6	$\overline{\text{DONE}}$	Open Drain Charge termination Status Output. In charge termination status, $\overline{\text{DONE}}$ is pulled low by an internal switch; Otherwise $\overline{\text{DONE}}$ pin is in high impedance state.
7	$\overline{\text{CHRG}}$	Open Drain Charge Status Output. When the battery is being charged, the $\overline{\text{CHRG}}$ pin is pulled low by an internal switch, otherwise $\overline{\text{CHRG}}$ pin is in high impedance state.
8	FB	Battery Voltage Kelvin Sense Input. This Pin can Kelvin sense the battery voltage; Also the regulation voltage in constant voltage mode can be adjusted by connecting an external resistor between FB pin and BAT pin.

Absolute Maximum Ratings

All Terminal Voltage..... -0.3V to 6.5V

BAT Short-Circuit Duration..... Continuous

Storage Temperature..... -65°C to 150°C

Thermal Resistance (SOP8)..... TBD

Maximum Junction Temperature..... 150°C

Operating Temperature..... -40°C to 85°C

Lead Temperature(Soldering)..... 260°C

Stresses beyond those listed under 'Absolute Maximum Ratings' may cause permanent damage to the device. These are stress ratings only and functional operation of the device at these or any other conditions above those indicated in the operational sections of the specifications is not implied. Exposure to Absolute Maximum Rating Conditions for extended periods may affect device reliability.

CONSONANCE

Electrical Characteristics

(VIN=5V, TA=−40°C to 85°C, Typical Values are measured at TA=25°C, unless otherwise noted)

Parameters	Symbol	Test Conditions	Min	Typ	Max	Unit
Input Supply Voltage	VIN		3.8		6	V
Operating Current	IVIN	Charge Termination Mode	300	450	600	μA
Undervoltage Lockout	Vuvlo	VIN falling		3.2	3.8	V
Regulation Voltage	VREG	Constant Voltage Mode	3.55	3.6	3.65	V
BAT pin Current	IBAT	R _{ISET} =2.436K, constant current	425	500	575	mA
		R _{ISET} =2.436K, Precharge mode	37.5	50	62.5	
		VIN=0V, sleep mode			3	μA
Precharge Threshold						
Precharge Threshold	V _{PRE}	FB voltage rise, FB tied to BAT	2.45	2.5	2.55	V
Precharge Threshold Hysteresis	H _{PRE}			0.1		V
Charge Termination Threshold						
Charge Termination Threshold	V _{term}	Measure voltage at I _{SET} pin	0.096	0.12	0.144	V
Recharge Threshold						
Recharge Threshold	V _{RECH}	FB voltage, FB tied to BAT		V _{REG} −0.3		V
Sleep Mode						
Sleep Mode Threshold	V _{SLP}	VIN from high to low, measures the voltage (VIN−VBAT)		10		mV
Sleep mode Release Threshold	V _{SLPR}	VIN from low to high, measures the voltage (VIN−VBAT)		60		mV
ISET Pin						
ISET Pin Voltage	V _{ISET}	Precharge mode V _{BAT} <2.5V		0.12		V
		Constant current mode		1.205		
FB PIN						
FB input current 1	IFB1	VFB=3.6V normal charging	1.8	3	6	μA
FB input current 2	IFB2	VIN<Vuvlo 或 VIN<VBAT			1	μA
TEMP PIN						
High Input Threshold	V _{HIGH}	The voltage at TEMP increases	77.5	80	82.5	% V _{IN}
Low Input Threshold	V _{LOW}	The voltage at TEMP decreases	42.5	45	47.5	% V _{IN}
TEMP input Current		TEMP to V _{IN} or to GND			0.5	μA
CHRG Pin						
CHRG Sink Current	I _{CHRG}	V _{CHRG} =0.3V, charge mode		10		mA
CHRG Leakage Current		V _{CHRG} =6V, termination mode			1	μA
DONE Pin						
DONE Sink Current	I _{DONE}	V _{DONE} =0.3V, termination mode		10		mA
DONE Leakage Current		V _{DONE} =6V, charge mode			1	μA

CONSONANCE

Detailed Description

The CN3058 is a linear battery charger designed specially for charging single cell LiFePO4 batteries. Featuring an internal P-channel power MOSFET, the charger uses a constant-current/constant-voltage to charge the batteries. Continuous charge current can be programmed up to 500mA with an external resistor. No blocking diode or sense resistor is required. The open-drain output $\overline{\text{DONE}}$ and $\overline{\text{CHRG}}$ indicates the charger's status. The internal thermal regulation circuit reduces the programmed charge current if the die temperature attempts to rise above a preset value of approximately 135°C. This feature protects the CN3058 from excessive temperature, and allows the user to push the limits of the power handling capability of a given circuit board without risk of damaging the CN3058 or the external components. Another benefit of adopting thermal regulation is that charge current can be set according to typical, not worst-case, ambient temperatures for a given application with the assurance that the charger will automatically reduce the current in worst-case conditions.

The charge cycle begins when the voltage at the VIN pin rises above the UVLO level, a current set resistor is connected from the ISET pin to ground. The $\overline{\text{CHRG}}$ pin outputs a logic low to indicate that the charge cycle is ongoing. At the beginning of the charge cycle, if the voltage at FB pin is below 2.5V, the charger is in precharge mode to bring the cell voltage up to a safe level for charging. The charger goes into the fast charge constant-current mode once the voltage on the FB pin rises above 2.5V. In constant current mode, the charge current is set by R_{ISET} . When the battery approaches the regulation voltage, the charge current begins to decrease as the CN3058 enters the constant-voltage mode. When the current drops to charge termination threshold, the charge cycle is terminated, $\overline{\text{DONE}}$ is pulled low by an internal switch and $\overline{\text{CHRG}}$ pin assumes a high impedance state to indicate that the charge cycle is terminated. The charge termination threshold is 10% of the current in constant current mode. To restart the charge cycle, remove the input voltage and reapply it. The charge cycle can also be automatically restarted if the FB pin voltage falls below the recharge threshold. The on-chip reference voltage, error amplifier and the resistor divider provide regulation voltage with 1.5% accuracy which can meet the requirement of LiFePO4 batteries. When the input voltage is not present, the charger goes into a sleep mode, dropping battery drain current to less than 3uA. This greatly reduces the current drain on the battery and increases the standby time.

The charging profile is shown in the following figure:

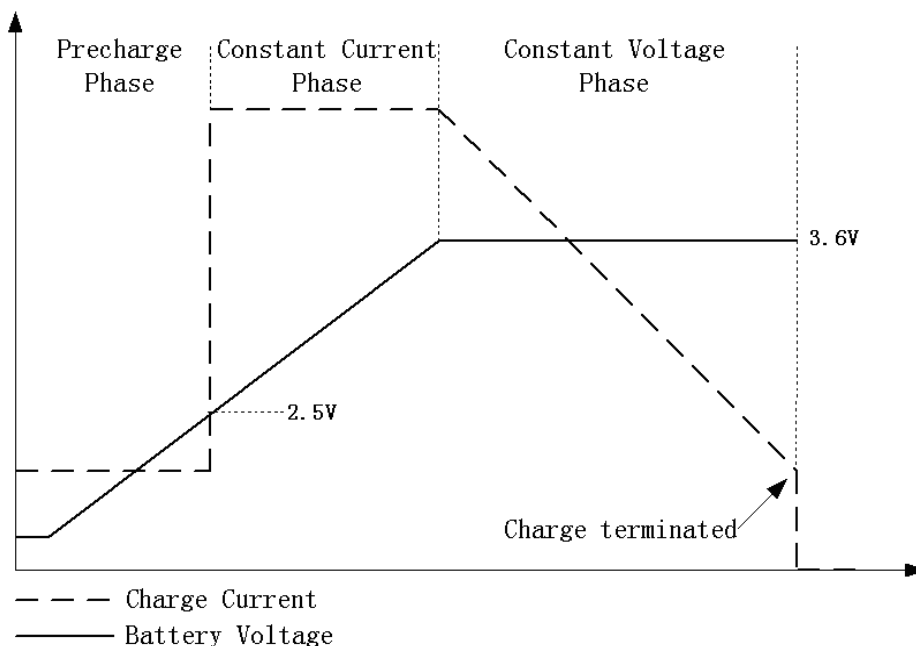

Figure 4 Charging Profile

CONSONANCE

Application Information

Undervoltage Lockout (UVLO)

An internal undervoltage lockout circuit monitors the input voltage and keeps the charger in shutdown mode until VIN rises above the undervoltage lockout voltage.

Sleep mode

There is an on-chip sleep comparator. The comparator keeps the charger in sleep mode if VIN falls below sleep mode threshold(VBAT+10mv). Once in sleep mode, the charger will not come out of sleep mode until VIN rises 50mv above the battery voltage.

Precharge mode

At the beginning of a charge cycle, if the battery voltage is below 2.5V(FB pin it tied to BAT pin), the charger goes into precharge mode , and the charge current is 10% of fast charge current in constant current mode.

If the regulation voltage in constant voltage mode is adjusted higher by a resistor between FB pin and BAT pin, the precharge threshold will change proportionally to the regulation voltage.

Adjusting the regulation voltage in constant voltage mode

The regulation voltage in constant voltage mode can be adjusted by an external resistor connecting between FB pin and BAT pin as shown in Figure 5:

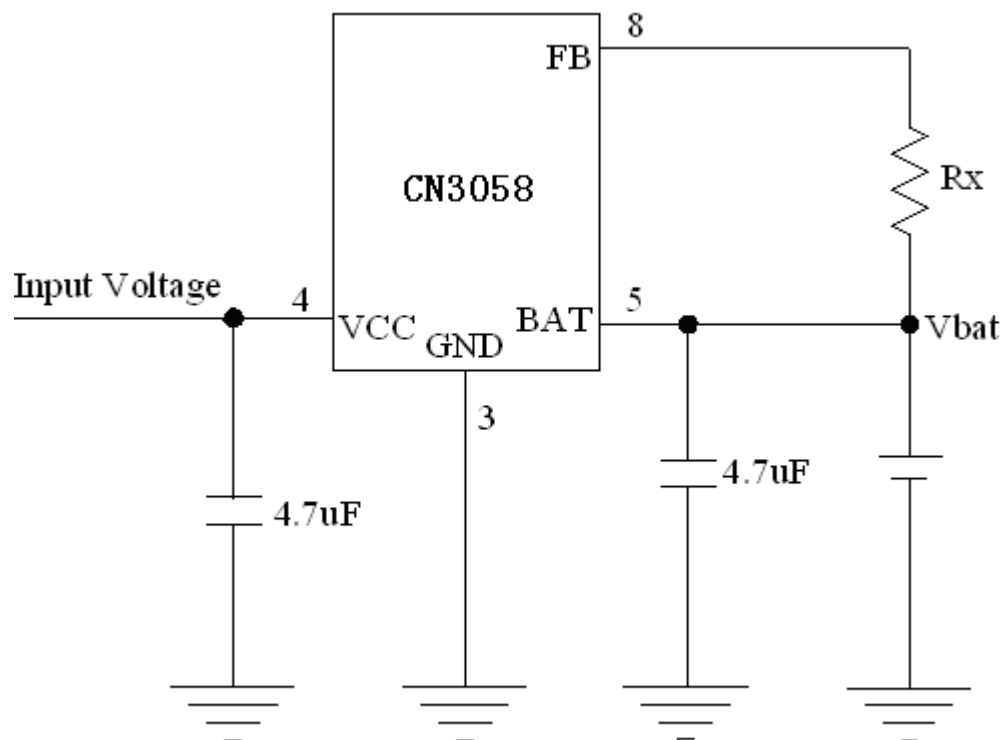

Figure 5 Adjusting Regulation Voltage in Constant Voltage Mode

In Figure 5, the regulation voltage in constant voltage mode will be given by the following equation:

$$V_{bat} = 3.6 + 3.61 \times 10^{-6} \times R_x$$

Where : V_{bat} is in volt
 R_x is in ohm

Setting Charge Current

The formula for the battery charge current in constant current mode is:

CONSONANCE

$$I_{CH} = 1218V / R_{ISET}$$

Where: I_{CH} is the charge current in ampere
 R_{ISET} is the total resistance from the ISET pin to ground in ohm

For example, if 500mA charge current is required, calculate:

$$R_{ISET} = 1218V / 0.5A = 2.436k \Omega$$

For best stability over temperature and time, 1% metal film resistors are recommended. If the charger is in constant-temperature or constant voltage mode, the charge current can be monitored by measuring the ISET pin voltage, and the charge current is calculated as the following equation:

$$I_{CH} = (V_{ISET} / R_{ISET}) \times 1011$$

Battery Temperature Sense

To prevent the damage caused by the very high or very low temperature done to the battery pack, the CN3058 continuously senses battery pack temperature by measuring the voltage at TEMP pin determined by the voltage divider circuit and the battery's internal NTC thermistor as shown in Figure 1.

The CN3058 compares the voltage at TEMP pin (V_{TEMP}) against its internal V_{LOW} and V_{HIGH} thresholds to determine if charging is allowed. In CN3058, V_{LOW} is fixed at $(45\% \times V_{IN})$, while V_{HIGH} is fixed at $(80\% \times V_{IN})$. If $V_{TEMP} < V_{LOW}$ or $V_{TEMP} > V_{HIGH}$, it indicates that the battery temperature is too high or too low and the charge cycle is suspended. When V_{TEMP} is between V_{LOW} and V_{HIGH} , the charge cycle resumes.

The battery temperature sense function can be disabled by connecting TEMP pin to GND.

Selecting R1 and R2

The values of R1 and R2 in the application circuit can be determined according to the assumed temperature monitor range and thermistor's values. The Follows is an example:

Assume temperature monitor range is $T_L \sim T_H$ ($T_L < T_H$); the thermistor in battery has negative temperature coefficient (NTC), R_{TL} is thermistor's resistance at T_L , R_{TH} is the resistance at T_H , so $R_{TL} > R_{TH}$, then at temperature T_L , the voltage at TEMP pin is:

$$V_{TEMP_L} = \frac{R_2 \parallel R_{TL}}{R_1 + R_2 \parallel R_{TL}} \times V_{IN}$$

At temperature T_H , the voltage at TEMP pin is:

$$V_{TEMP_H} = \frac{R_2 \parallel R_{TH}}{R_1 + R_2 \parallel R_{TH}} \times V_{IN}$$

We know, $V_{TEMP_L} = V_{HIGH} = k_2 \times V_{IN}$ ($k_2 = 0.8$)

$$V_{TEMP_H} = V_{LOW} = k_1 \times V_{IN} \quad (k_1 = 0.45)$$

Then we can have:

$$R_1 = \frac{R_{TL} R_{TH} (k_2 - k_1)}{(R_{TL} - R_{TH}) k_1 k_2}$$

$$R_2 = \frac{R_{TL} R_{TH} (k_2 - k_1)}{R_{TL} (k_1 - k_1 k_2) - R_{TH} (k_2 - k_1 k_2)}$$

Likewise, for positive temperature coefficient thermistor in battery, we have $R_{TH} > R_{TL}$ and we can calculate:

$$R_1 = \frac{R_{TL} R_{TH} (k_2 - k_1)}{(R_{TH} - R_{TL}) k_1 k_2}$$

$$R_2 = \frac{R_{TL} R_{TH} (k_2 - k_1)}{R_{TH} (k_1 - k_1 k_2) - R_{TL} (k_2 - k_1 k_2)}$$

CONSONANCE

We can conclude that temperature monitor range is independent of power supply voltage VIN and it only depends on R1, R2, R_{TL} and R_{TH}: The values of R_{TH} and R_{TL} can be found in related battery handbook or deduced from testing data.

In actual application, if only one terminal temperature is concerned (normally protecting overheating), there is no need to use R2 but R1. It becomes very simple to calculate R1 in this case.

Recharge

After a charge cycle has terminated, if the battery voltage drops below the recharge threshold (3.3V if FB pin is tied to BAT pin), a new charge cycle will begin automatically.

If the regulation voltage in constant voltage mode is adjusted higher by a resistor between FB pin and BAT pin, the recharge threshold will change proportionally to the regulation voltage.

Constant-Current/Constant-Voltage/Constant-Temperature

The CN3058 use a unique architecture to charge a battery in a constant-current, constant-voltage, constant temperature fashion as shown in Figure 3. Amplifiers Iamp, Vamp, and Tamp are used in three separate feedback loops to force the charger into constant-current, constant-voltage, or constant-temperature mode, respectively. In constant current mode the charge current delivered to the battery equal to $1218V/R_{ISET}$. If the power dissipation of the CN3058 results in the junction temperature approaching 135°C, the amplifier Tamp will begin decreasing the charge current to limit the die temperature to approximately 135°C. As the battery voltage rises, the CN3058 either returns to constant-current mode or it enters constant voltage mode straight from constant-temperature mode.

Open-Drain Status Outputs

The CN3058 have 2 open-drain status outputs: \overline{CHRG} and \overline{DONE} . \overline{DONE} is pulled low when the charger is in charging status, otherwise \overline{DONE} becomes high impedance. \overline{CHRG} is pulled low when the charger is in charging status, otherwise \overline{CHRG} becomes high impedance. When the battery is not present, the charger charges the output capacitor to the regulation voltage quickly, then the BAT pin's voltage decays slowly to recharge threshold because of low leakage current at BAT pin, which results in a 300mv ripple waveform at BAT pin.

The open drain status output that is not used should be tied to ground.

The following table lists the two indicator status and its corresponding charging state. It is supposed that red LED is connected to \overline{CHRG} pin and green LED is connected to \overline{DONE} pin.

\overline{CHRG} pin	\overline{DONE} pin	State Description
Low(the red LED on)	High(the green LED off)	Charging
High(the red LED on)	Low(the green LED off)	Charge termination
High(the red LED off)	High(the green LED off)	There are three possible situations: <ul style="list-style-type: none">● the voltage at the VIN pin below the UVLO level or● the voltage at the VIN pin below V_{BAT} or● abnormal battery's temp or

VIN Bypass Capacitor

In most applications, a high-frequency bypass capacitor(C1 in Figure 1 and 2) is needed for input supply.

Generally, a 1uF ceramic capacitor, placed in close proximity to VIN and GND pins, works well. In some applications depending on the power supply characteristics and cable length, it may be necessary to increase the capacitor's value.

For the consideration of the bypass capacitor, please refer to the Application Note AN102 from our website.

CONSONANCE

Stability

Typically a 4.7uF to 10uF capacitor(C2 in Figure 1 and 2) from BAT pin to GND is required to stabilize the feedback loop.

In constant current mode, the stability is also affected by the impedance at the ISET pin . With no additional capacitance on the ISET pin, the loop is stable with current set resistors values as high as 50K Ω . However, additional capacitance on ISET pin reduces the maximum allowed current set resistor. The pole frequency at ISET pin should be kept above 200KHz. Therefore, if ISET pin is loaded with a capacitance C, the following equation should be used to calculate the maximum resistance value for R_{ISET}:

$$R_{ISET} < 1 / (6.28 \times 2 \times 10^5 \times C)$$

Board Layout Considerations

1. R_{ISET} at ISET pin should be as close to CN3058 as possible, also the parasitic capacitance at ISET pin should be kept as small as possible.
2. The capacitance at VIN pin and BAT pin should be as close to CN3058 as possible.
3. During charging, CN3058's temperature may be high, the NTC thermistor should be placed far enough to CN3058 so that the thermistor can reflect the battery's temperature correctly.
4. It is very important to use a good thermal PC board layout to maximize charging current. The thermal path for the heat generated by the IC is from the die to the copper lead frame through the package lead(especially the ground lead) to the PC board copper, the PC board copper is the heat sink. The footprint copper pads should be as wide as possible and expand out to larger copper areas to spread and dissipate the heat to the surrounding ambient. Feedthrough vias to inner or backside copper layers are also useful in improving the overall thermal performance of the charger. Other heat sources on the board, not related to the charger, must also be considered when designing a PC board layout because they will affect overall temperature rise and the maximum charge current.

The ability to deliver maximum charge current under all conditions require that the exposed metal pad on the back side of the CN3058 package be soldered to the PC board ground. Failure to make the thermal contact between the exposed pad on the backside of the package and the copper board will result in larger thermal resistance.

CONSONANCE

Package Information

SOP8 PACKAGE OUTLINE DIMENSIONS

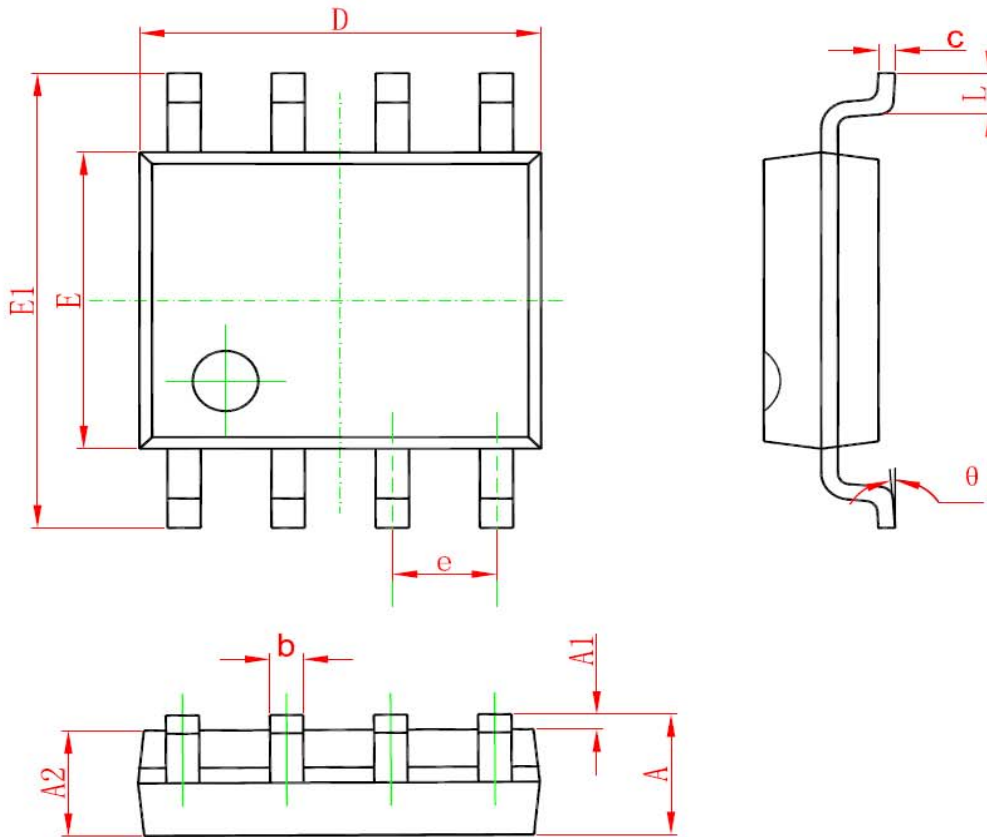

Symbol	Dimensions In Millimeters		Dimensions In Inches	
	Min	Max	Min	Max
A	1.350	1.750	0.053	0.069
A1	0.100	0.250	0.004	0.010
A2	1.350	1.550	0.053	0.061
b	0.330	0.510	0.013	0.020
c	0.170	0.250	0.006	0.010
D	4.700	5.100	0.185	0.200
E	3.800	4.000	0.150	0.157
E1	5.800	6.200	0.228	0.244
e	1.270 (BSC)		0.050 (BSC)	
L	0.400	1.270	0.016	0.050
θ	0°	8°	0°	8°

Consonance does not assume any responsibility for use of any circuitry described. Consonance reserves the right to change the circuitry and specifications without notice at any time.