

TDA2086

T-65-09

PHASE CONTROL INTEGRATED CIRCUIT

The TDA2086 is a silicon integrated circuit designed for use in closed or open loop phase control circuits of AC with resistive or inductive loads. In closed loop systems analog voltage or tachometer frequency feedback may be used.

The circuit was primarily designed for motor speed control in power drills, food mixers, washing machines etc.

In the event of an open circuit tachometer generator connection the TDA2086 will demand full speed/power.

FEATURES

- Power Direct from AC Mains or DC Line
- 5V Supply Available for Ancillary Circuitry
- Low Supply Current Consumption
- Average or Peak Load Current Limiting
- Ramp Generator to Provide Controlled Acceleration
- Negative Triac Firing Pulses
- 100mA Guaranteed Minimum
- Warning LED Drive Circuit
- Actual Speed Derived from Tachogenerator Frequency or Analog Feedback
- Well Defined Control Voltage\$Phase Angle Relationship
- Inhibit Input for use with Thermistor Temperature Sensors

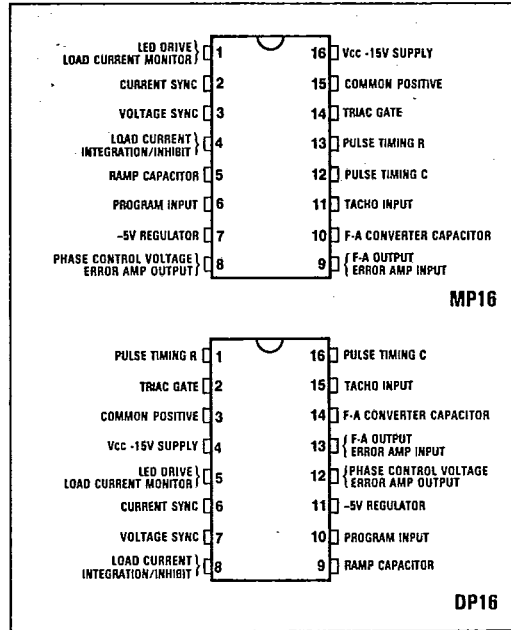

Fig.1 Pin connections - top view

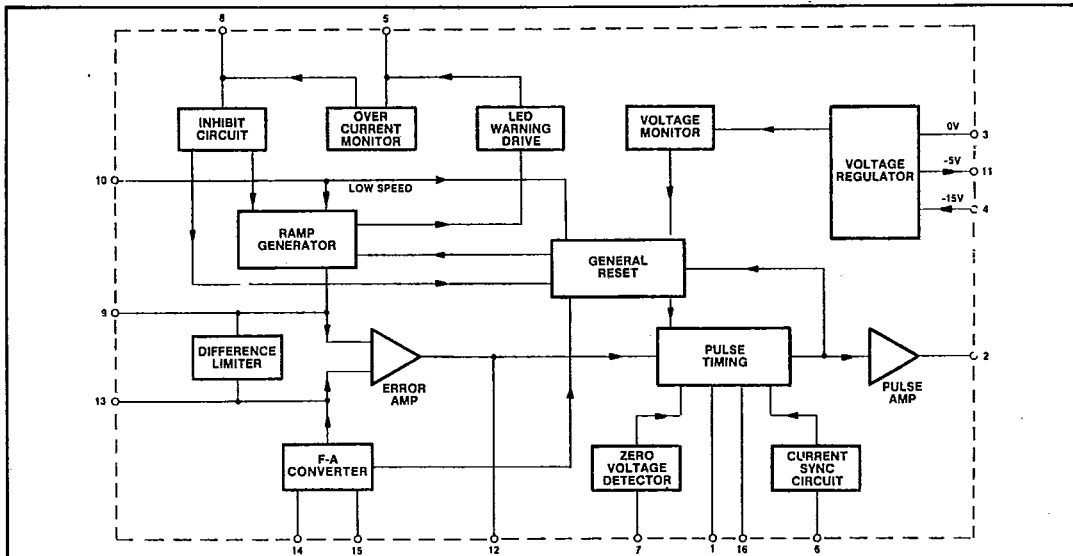

Fig.2 Block diagram of TDA2086

ELECTRICAL CHARACTERISTICS

Tests conditions (unless otherwise stated):

$T_{amb} = +25^{\circ}C$

All potentials measured with respect to common (Pin 3) (unless otherwise stated)

Pin numbers refer to DP16 package

T-65-09

Characteristic	Value			Units	Conditions
	Min.	Typ.	Max.		
CURRENT CONSUMPTION					
Pin 4					
IC Operating current		3.1	4.1	mA	Pin 4 voltage = 13.5V including triac gate drive current
SHUNT VOLTAGE REGULATOR					
Pin 4					
Regulating voltage	-16	-14.75	-13.5	V	Full temperature range
Voltage monitor enable level	-11		-9	V	
SERIES REGULATOR					
Pin 11					
Regulating voltage (Vreg)	-5.35	-5	-4.65	V	1mA external load
Temperature coefficient			± 1	mV/ $^{\circ}C$	
External load			10	mA	For 0-5mA external load change
Regulation	-75		+75	mV	
RAMP GENERATOR					
Pin 9					
Capacitor charging current	25	30	35	μA	Load current limit in operation Load current inhibit in operation 5V on ramp C
Capacitor discharge current		25		μA	
Capacitor discharge current		10		mA	
Capacitor to actual speed voltage clamp	-0.8		+0.8	V	
SPEED PROGRAM CIRCUIT					
Pin 10					
Input voltage range	Vreg -0.5		0	V	
Input bias current			1	μA	
Zero power demand voltage	-100	-75	-50	mV	
FREQUENCY TO ANALOG CONVERTER					
Pin 15					
Tacho input voltage	100			mV	Peak value
Hysteresis	30	40	60	mV	
Bias current			10	μA	
Pin 15 to Pin 14					
Conversion factor (typical application)		0.5		mV/rpm	C pin 14 = 10nF, R pin 13 = 150k, 8 pole tacho 10000 rpm max.
Pin 4 to Pin 13					
Conversion gain		1			
ERROR AMPLIFIER					
Pin 9 and 13					
Input voltage range	Vreg		0	V	
Input bias current			0.5	μA	
Pin 10, 13 and 12					
Input offset voltage	-5		+15	mV	V10-V13 to give $I_{t2} = 0$
Transconductance	80	100	120	$\mu A/V$	
Pin 12					
Output current drive	± 20		± 35	μA	

ELECTRICAL CHARACTERISTICS

Characteristic	Value			Units	Conditions
	Min.	Typ.	Max.		
FIRING PULSE TIMING					
Pin 7 Voltage SYNC trip level	±35	±50	±65	μA	
Pin 6 Current SYNC trip level	±35	±50	±65	μA	
Pin 12 Phase control voltage swing	Vreg		0	V	
Pin 13 Firing pulse width		50		μs	C pin 16 = 47nF C pin 16 = 47nF, R pin 1 = 200k
Pulse repetition time		100		μs	
FIRING PULSE OUTPUT					
Pin 2 Drive current	100	125	150	mA	Pin 2 V = -3V
Leakage current			10μA		Pin 2 V = 0V
LOAD CURRENT LIMITING					
Pin 5 Offset voltage			±20	mV	
Pin 5 and 8 Current gain	0.475	0.5	0.525		Pin 5 current = 100μA
Pin 8 Voltage for load current limit		-1V			(0.2 Vreg)
Voltage for load current inhibit		-1.5V			(0.3 Vreg)

ABSOLUTE MAXIMUM RATINGS

ELECTRICAL	Value	Units
Triac gate voltage pin 2	4	V
Repetitive peak input current pin 4	80	mA
Non repetitive peak input current pin 4 (tp 250μs)	200	mA
Peak input current pin 5 positive half cycle	2	mA
Repetitive peak input current pin 5 negative half cycle	80	mA
Non repetitive peak input current pin 5 negative half cycle (tp 250μs)	200	mA
Peak input current (I _{sync}) pin 6	±1	mA
Peak input current (V _{sync}) pin 7	±1	mA
Inhibit input voltage pin 8	Vreg	V
-5V regulator current pin 11	10	mA
Control amp input voltage pin 13	Vreg	V
Tacho input current pin 15	±20	mA
THERMAL		
Operating ambient temperature	0 to +85	°C
Storage temperature	-55 to +125	°C

TACHO INPUT DRIVE

The TDA2086 requires less than 10μA (pk) to drive the tacho input (pin 15) and has bidirectional clamping. This makes it possible to connect a tacho pick up coil directly to the device hence minimising component count.

A motor may fail to start up if a signal is picked up by a sensitive tacho due to vibration in the rotor caused by elastic sticktion when power is initially applied. This can be easily overcome by incorporating a filtering capacitor across the tacho input.

SPECIAL FEATURES

Low Supply Current Consumption

Due to the low current consumption of the device the power dissipation in the mains dropper resistor may be as low as 1.1W on a 220V AC supply (0.5W on 110V).

By incorporating both a shunt and a series voltage regulator in the IC design, a high ripple voltage can be accommodated on the supply smoothing capacitor.

The combination of the above two features result in reduced size and a minimum count of components used in the power supply circuitry.

Powered Direct from AC Mains or DC Line

This device incorporates a shunt regulator (-15V) such that it may be powered from an AC or DC supply via current limiting components or the device may be powered direct from a -12V DC supply.

-5V Supply available for Ancillary Circuitry

A -5V series regulator is incorporated to provide a smooth supply for the internal analog control functions. This supply may be used externally to power ancillary circuitry such as timing circuits and other logic control circuits etc, as well as driving potentiometers for the analog control inputs.

Due to this supply technique, greater symmetry between positive and negative half cycle firing phase angle will result.

Low Supply Inhibit Circuit

Timing functions and triac gate drive pulses are inhibited until there is sufficient supply voltage across the device to guarantee complete gate drive pulses.

This ensures that bulk conduction is established in the triac and correct linear operation of the control system is maintained.

Negative Triac Gate Firing Pulses

Since the device works with the positive supply as common, the triac gate pulses are negative going. This is an advantage when selecting a suitable triac since most triac manufacturers prefer this drive polarity.

The device is designed to give a triac pulse that is greater than 100mA for a period of 50 microseconds with standard pulse timing components (47nF, pin 16). Repeated triac gate pulses are given if the triac fails to latch or becomes unlatched due to motor brush bounce.

Well-Defined Control Voltage/Phase Angle (Open Loop)

An internal 5V stabiliser circuit is used as the charging voltage for the pulse timing ramp capacitor and as the reference voltage for the speed input potentiometer. This ensures that maximum phase angle can be obtained by adjusting the resistor or capacitor on the pulse timing circuit, without affecting the maximum setting.

Average or Peak Load Current Limiting

The load current is normally sensed in the positive mains cycle by means of a low impedance resistor in series with the triac and load. The voltage drop across this resistor is converted back into a low current source by a second resistor and fed into the load current sensing input (pin 5) of the IC. In high load current applications where the power dissipated in a series sensing resistor would be

unacceptable, a current transformer may be utilised.

The current fed into the sensing input (pin 5) is mirrored by the IC and fed to the inhibit input (pin 8). Peak current limiting can be provided at this point by inserting a resistor between pin 8 and common (pin 3), whereas average current limiting requires the addition of an integrating capacitor.

When average current limiting is used the double action of the inhibit circuit is utilised. This has two trip points such that when the first trip point (-1V) is reached the power to the load will be gradually reduced by decreasing the voltage on the ramp capacitor, (the discharge rate being equal but opposite to the soft start), hence reducing the power and providing a constant current drive (producing constant torque) to the motor. When the second trip point (-1.5V) is reached a general reset of all timing functions occurs at a fast rate, hence if a gross overload was suddenly applied to the motor, a rapid reduction in power supplied would result. Since it is not possible to turn the triac off during a cycle, the triac and motor should be chosen to be capable of withstanding one complete mains cycle under the worst overload condition.

Peak load current limiting tends to produce a fold back action (of motor speed and torque) at large conduction phase angle. This is due to the peak current initially increasing when the phase conduction angle is reduced at constant load torque.

Ramp Generator to provide Controlled Acceleration

The ramp generator is a follower integrator design which can be used to control the acceleration rate up to the programmed speed. This can also be used to control the rate of phase angle increase in open loop control systems.

The ramp rate is defined by an internal current source (25 microamps) and the capacitor connected to pin 9.

Warning LED Drive Circuit

The LED drive circuit is designed to drive an LED in series with the device such that the overall current consumption is minimised by utilising the IC drive current to power the LED. Due to the multiplexing technique on pin 5, some additional current will be required when the circuit is used to provide both load current limit and LED drive (this will normally be about 0.5mA).

The LED will illuminate under one of the following two conditions:

1. The programme speed (or phase in open loop systems) is set for zero.
2. The running speed is less than that programmed.

Hence, indication will be given when the system is powered up but zero power demanded, or when the machine cannot maintain the set operating speed due to the load current circuit operating. The LED will also be illuminated while the soft start function is in operation i.e., the LED will turn off only when the set speed has been reached.

Actual Speed Derived from Tacho Generator Frequency or Analog Feedback

Tacho frequency or analog feedback may be used with this device. When frequency feedback is used, the frequency to analog (F-A) conversion circuit is used. This circuit is extremely linear and tracks the regulated (-5V) supply.

Frequency feedback has the advantage of not being dependent on mechanical clearance, magnetic strength, etc., and since the conversion rate is defined by two external components, accurate speed programming can be obtained without the need for calibration.

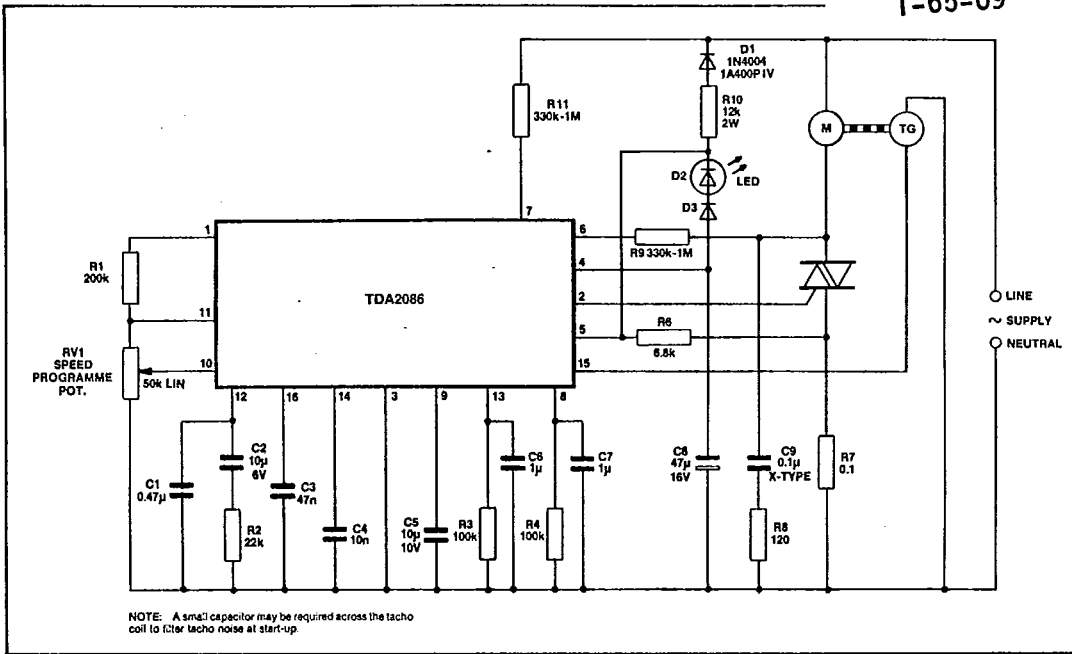

Fig.3 Universal motor application